

Mounting and installation manual

Sliding gate operators TPS 20



TPS 20



TPS 20N







TPS 20 PRO



tousek[®]
G A T E A U T O M A T I O N



	General warning and safety details	3
1.	Notes, general characteristics, function, technical data TPS 20 (N, PRO)	4
2.	Mounting	5
	Technical layout TPS 20, TPS 20N, TPS 20 PRO	5–7
2.1	Mounting of the motor	8
	Mounting dimensions TPS 20, TPS 20N, TPS 20 PRO	8–10
2.2	Mounting of the gear rack	11
2.3	Dismantling	11
3.	Control unit, overview TPS 20, TPS 20N	12
	Warnings - connection works	13
3.1	Clamp/terminal assignment TPS 20, TPS 20N	13
3.2	Control box TPS 20 PRO	14
	Warnings - connection works	14
3.3	Clamp/terminal assignment TPS 20 PRO	15
3.4	Adjustments - overview, Programming keys, program menu, basic settings	16
	Structure of the menu	17
3.5	Connections and adjustments	18
	Buttons/switches	18
	Impulse button (terminals 30/32)	18
	Pedestrian function (terminals 30/34)	18
	Pedestrian button (terminals 30/34)	19
	CLOSE switch (terminals 30/33)	19
	STOP switch (terminals 30/31)	19
	Emergency mode	19
	Safety	20
	Photocell (Contact: terminals 45/46)	20
	PHC-back area (Contact: terminals 45/48)	20
	PHC-function	20
	PHC-pause time	20
	PHC-selftest	20
	<i>Photocells - connection examples</i>	20
	Safety edges	22
	Main clos. edge (terminals 50/51)	23
	Side edge 1 OPEN (terminals 50/52)	23
	Side edge 2 CLOSE (terminals 50/55)	23
	Side edge 3 OPEN (terminals 50/56)	23
	SE-status display	23
	Motor	24
	Max. force, Increased starting force, ARS response time,	
	Speed, Soft way, Soft speed, End position OPEN, End position CLOSE	24
	Operating mode	24
	Impulse mode	24
	Opening direction	24
	Operating mode	24
	Partial opening	25
	Automatic mode	25
	Pause time logic	25
	Additional module	25
	Traffic light	25
	<i>Description of add. modules courtyard lamp/control lamp hence gate status display</i>	26
	Lights / lamps	27
	Prewarning OPEN (signal lamp: terminals 10/11)	27
	Prewarning CLOSE (signal lamp: terminals 10/11)	27
	Green phase, Leave time, Traffic light gate closed, Traffic light logic	27
	Courtyard lamp	27
	Control lamp	27
	Diagnosis	28
	Status display, Delete end positions, Factory setting,	28
	Software version, Serial number, Protocoll, Status Sensor	28
3.6	Other connections of TPS 20 PRO	29
4.	Sockets of TPS 20 PRO (for optional radio receiver and induction loop detector)	29
5.	Connection of radio receiver	30
6.	Initial operation	31
7.	Emergency release in case of power failure (note for the user)	33
8.	Optional traffic light control unit STA 11	34–39
9.	Error diagnosis	40
10.	Cable plan	41
11.	Dimensioned drawings TPS 20, TPS 20N, TPS 20 PRO	42–44



GENERAL WARNING AND SAFETY NOTES

- These installation and operating instructions form an integral part of the product “sliding gate operator”. They have been specifically written for professional installers trained and skilled in the trade and should be carefully read in their full length before carrying out the installation. They describe the proper installation and operation of the sliding gate operator only, not of the overall device “automatic gate”. After the installation this manual has to be handed over to the user.
- Installation, connection, adjustments, putting into operation, and servicing may only be carried out by trained professionals in full accordance with these installation- and operating instructions.
- Before carrying out works at the gate-system, the power supply has to be turned off.
- The EU Machine Directive, laws and rules concerning the prevention of accidents, and laws and standards which are in force in the EU and in the individual countries have to be strictly followed.
- The TOUSEK Ges.m.b.H. cannot be held liable for any claims resulting from disregards of the laws and standards in force during the installation and operation.
- The packaging materials (cardboard, plastic, EPS foam parts and filling material etc.) have to be properly disposed of in accordance with the applying recycling- and environmental protection laws. They may be hazardous to children and therefore have to be stored out of children’s reach.
- The product is not suitable for installation in explosion-hazardous areas.
- The product may only be used in accordance with its original purpose, for which it has been exclusively designed, and which is described in these installation and operating instructions. The TOUSEK Ges.m.b.H. rejects any liability if the product is used in any way not fully conforming to its original purpose as stated herein.
- Children have to be instructed, that the gate facility as well as the belonging parts may not be used improperly, e.g. for playing. Furthermore handheld transmitters have to be kept in safe places and other impulse emitters as buttons and switches have to be installed out of children’s reach.
- Before beginning with the installation the installer has to make sure that all mechanical components of the gate facility, like carrier profile/rail, gate frame and panels, guiding elements etc. are sufficiently supportive and resistant for the purpose of gate automation.
- All electrical installations have to be made in full conformity with the applying rules and laws (e.g. using a fault current circuit breaker, proper grounding etc.).
- An all-pole disconnecting main switch with a contact opening-gap of minimum 3 mm has to be foreseen.
- The electric motor heats up during operation. Therefore the device should only be touched after it has cooled off.
- After installation the proper function of the gate facility and the safety devices has to be checked!
- The TOUSEK Ges.m.b.H. rejects any liability for claims resulting from usage of the product in combination with components or devices which do not fully conform to the applying safety laws and rules.
- Only original spare- and replacement parts may be used for repair of the product.
- The installer has to inform the user about all aspects of the automatic operation of the complete gate facility, as well as about emergency operation. The installer further has to supply to the user all instructions relating to the safe operation of the gate facility. The installation and operating instructions also have to be handed over to the user.
- **Please notice that the warranty will not be applicable if the label with the engine number has been removed or damaged.**



Maintenance

- **Maintenance works may only be carried out by qualified personnel.**
- **Check the proper sensitivity setting of the ARS safety reverse system once a month.**
- **Check the proper function of the emergency release mechanism periodically.**
- **Check if all mounting screws are securely fastened periodically.**
- **Remove dirt deposits from the operator and gear rack periodically.**
- **Maintenance and servicing of the complete gate facility has to be carried out according to the gate builder’s/ installer’s instructions.**

Characteristics TPS 20

- Suitable for heavy duty use (80% duty cycle)
- Large, illuminated LC-Display (2x16 characters)
- Clear text menu programmable via four buttons
- Operation mode is selectable (Impulse, Automatic, Deadman)
- Free adjustable partial opening for pedestrians or car/truck function
- Distance measurement made via speed sensor (without limit switches)
- Adjustable soft stop (distance and speed)
- Ramp shaped soft start (approx. 1s)
- ARS – Automatic Reversal System
- Mechanical brake for safe gate stop
- Permanent self-regulating force with boost function (increased start force)
- Electronic monitoring of emergency release
- Direct connection of four separate 8,2 kΩ safety contact edges
- Input for gate back area surveillance
- Status display for safety and button/switches inputs
- Self-monitoring of photocell
- Connection slot for radio receiver
- Optional, external gate status display (e.g. for concierge)
- Optional courtyard lamp module (230V, 100W)
- 2 x 130mm DIN rail for additional accessories
- Dimension (W x H x D): 616 x 532 x 211mm
- Height adjustable gear wheel: 100–175mm

Further characteristics TPS 20N

- Galvanized base housing
- 260mm DIN-rail for additional accessories
- Dimension (W x H x D): 328 x 950 x 188mm
- Height adjustable gear wheel: 107–147mm



Further characteristics TPS 20 PRO

- Main housing made of powdercoated, galvanized steel
- Door made of powdercoated aluminium and lockable with standard cylinder
- Optional, height adjustable for or angle for signal transmission system
- Integrated main power switch and 230V Schuko plug
- Built-in photocell LS45 (30m range)
- 2 x 120mm DIN-rail for additional accessories
- Dimension (W x H x D): 520 x 995 x 230mm
- Height adjustable gear wheel: 120–200mm

Technical data

Sliding gate operator TPS-	20	20N	20 PRO		20	20N	20 PRO
Control unit	integrated			Max. drive	30m		
Power supply	230V a.c., 50Hz			duty cycle in S3 mode	80%		
motor voltage	230V a.c.				Ambient temperature	-20°C +40°C	
max. current consumption (excl. equipment)	4A			Protection class	IP44		
Gear wheel	Z15M4			Torque sensor	■		
Max. gate weight	2000kg			Article no.	11110460	11110470	11110480
Speed	14m/min						
Torque	45Nm						
Increased starting torque	65Nm						
Optional equipment	pluggable receiver • additional module für courtyard/control lamp • additional module for gate status • Traffic light control unit • radio transmission system TX 310 • inductive system TX 400i						



General installation notes

Before installing the **Tousek TPS 20** sliding gate operator we recommend checking the following points:

- **Checking the gate structure:**
On a gate which travels on floor rails please check the bottom rollers and the upper guide rollers and make sure that there is no undue friction or jamming.
On a cantilever gate please check if the gate can be moved out of its end-positions without undue effort.
- The gate must travel in a stable manner without lateral movements of the gate panel.
- Make sure that the gate travels in a regular way without undue friction or jamming along the whole travel length.
- **Make sure that there are stoppers at both ends of the track, preventing the gate from running over its travel limit.**

Technical layout TPS 20

- (1) Ground plate
- (1a) Cable inlet
- (1b) Slotted holes (4x) for mounting on the foundation/ground
- (2) Gear wheel
- (3) Emergency release
- (4) Control unit with optional radio receiver (pluggable)
- (4a) Boost condenser
- (5) speed sensor
- (6) Motor-/gear unit
- (6a) Motor condenser
- (7) DIN rail for additional equipment

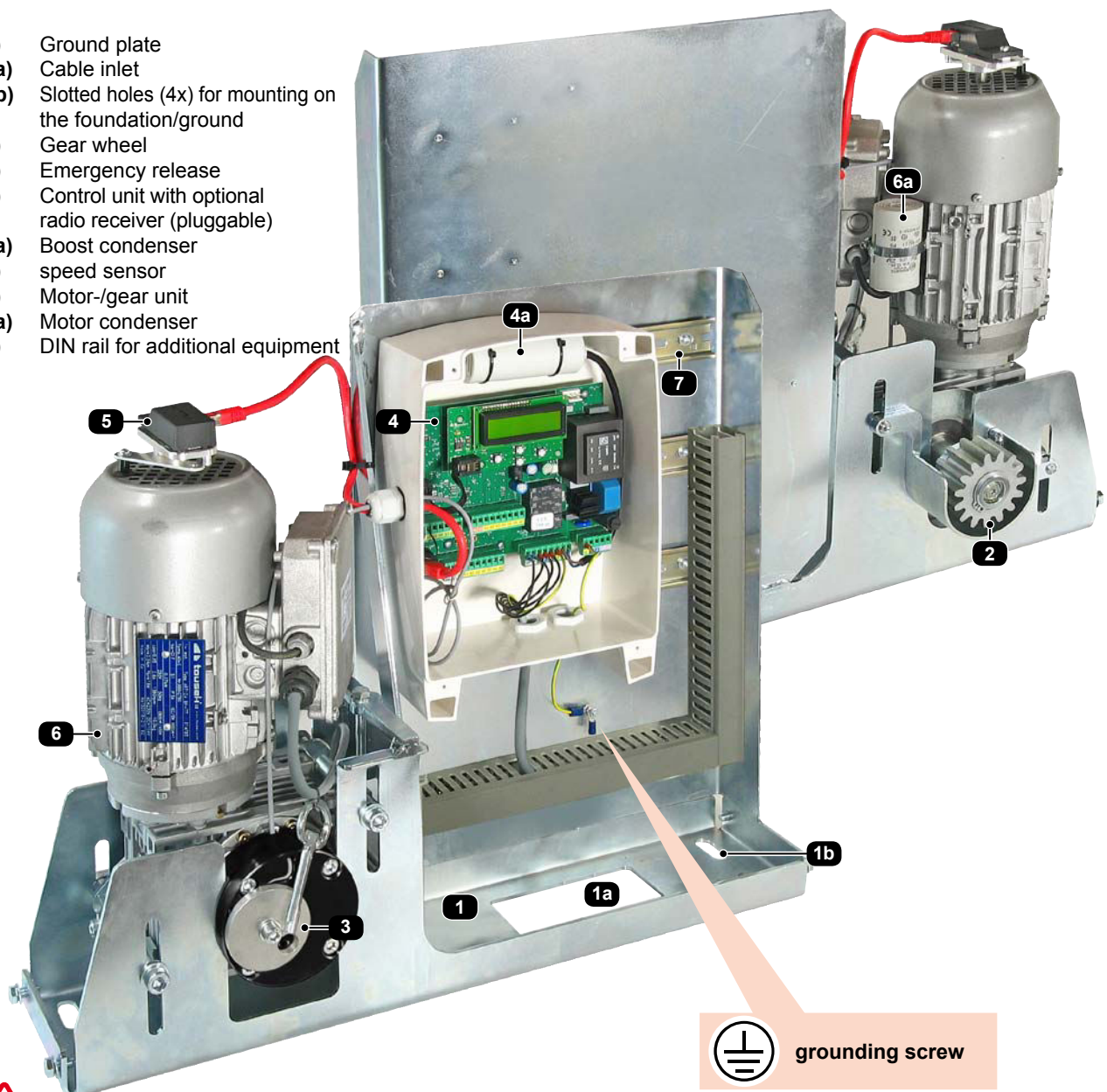

ATTENTION !

- **ATTENTION: Mechanical limits are necessary!**
- **ATTENTION: the sliding gate operator TPS 20 has been developed and designed for the automation of horizontally travelling sliding gates. Gates on sloping tracks (i.e. gates which follow an inclined, non-horizontal, travel path) must not be automated without additional safety devices (which make sure that the gate cannot start moving on its own from any gate position).**

Technical layout TPS 20N

- (1) Ground plate
- (1a) Cable inlet
- (1b) Slotted holes (4x) for mounting on the foundation/ground
- (2) Gear wheel
- (3) Emergency release
- (4) Control unit with optional radio receiver (pluggable)
- (4a) Boost condenser
- (5) speed sensor
- (6) Motor-/gear unit
- (6a) Motor condenser
- (7) DIN rail for additional equipment



ATTENTION !

- **ATTENTION: Mechanical limits are necessary!**
- **ATTENTION: the sliding gate operator TPS 20N has been developed and designed for the automation of horizontally travelling sliding gates. Gates on sloping tracks (i.e. gates which follow an inclined, non-horizontal, travel path) must not be automated without additional safety devices (which make sure that the gate cannot start moving on its own from any gate position).**

Technical layout TPS 20 PRO

- (1) Ground plate
- (1a) Cable inlet
- (1b) Slotted holes (4x) for mounting on the foundation/ground
- (2) Gear wheel
- (3) Emergency release
- (4) Control box
- (5) speed sensor
- (6) Motor-/gear unit
- (7) Photocell LS 45
- (7a) Opening for photocell
- (8) Main switch
- (9) Height adjustable bracket for signal transmission system (optional)
- (9a) Slot for fork bracket for power supply systems
- (10) Safety sensing edges (optional)
- (11) Cabinet lock (profile half cylinder)

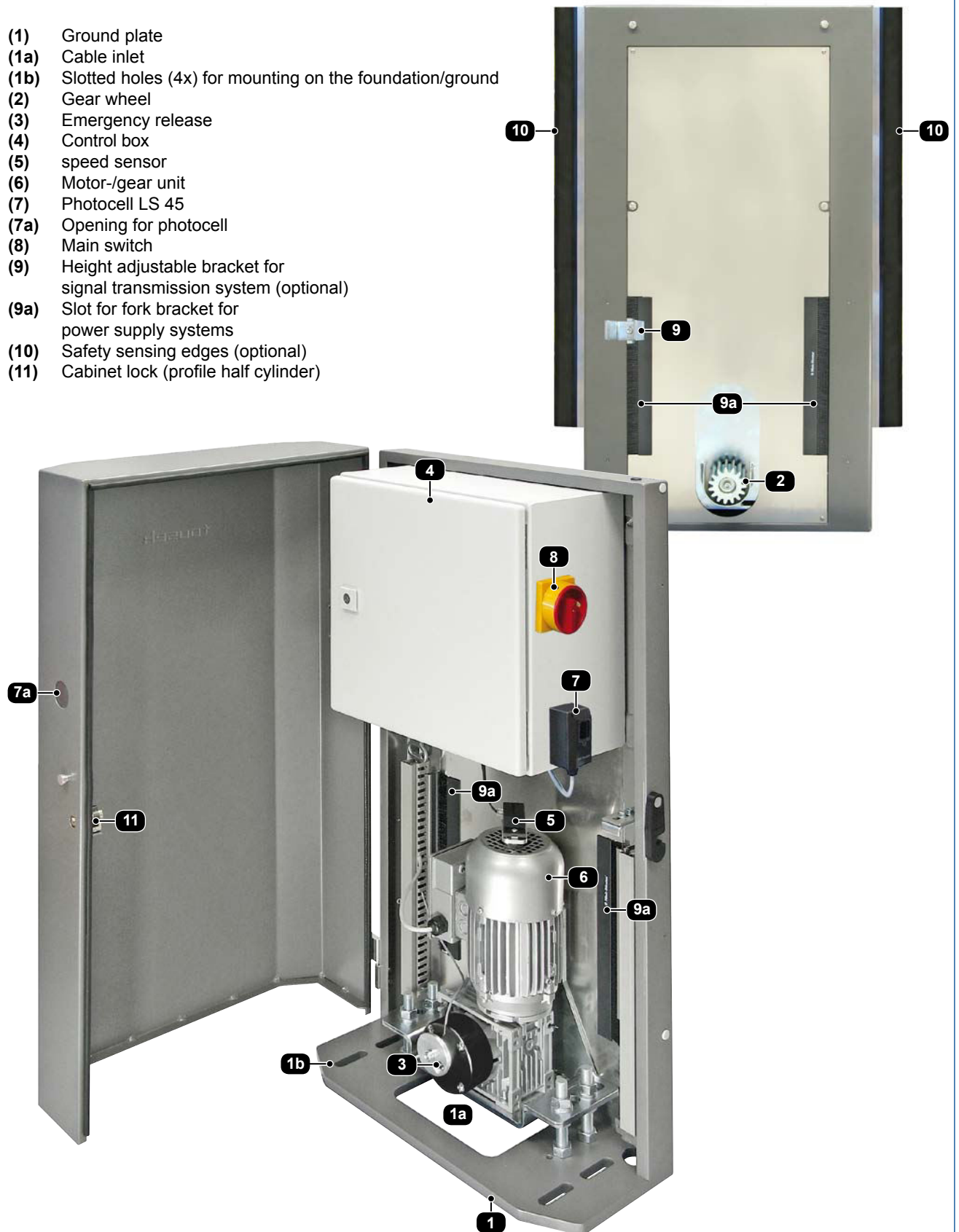

ATTENTION !

- **ATTENTION: Mechanical limits are necessary!**
- **ATTENTION: the sliding gate operator TPS 20 PRO has been developed and designed for the automation of horizontally travelling sliding gates. Gates on sloping tracks (i.e. gates which follow an inclined, non-horizontal, travel path) must not be automated without additional safety devices (which make sure that the gate cannot start moving on its own from any gate position).**

After installing the protection tubes (**check cable exit of operator (1a)**) and having finished the concrete foundation, the motor has to be bolted through the 4 slotted holes (**1b**) to the concrete foundation. It is particularly important that the operator is mounted parallel to the gate panel, and that the measurements given in the drawing are kept.



NOTE concerning cable laying

- The electric cables have to be laid in insulating sleeves which are suitable for underground usage. The insulating sleeves have to be lead into the inner of the operator housing (see picture).
- 230V cables and control lines have to be laid in separate sleeves.
- Only double-insulated cables, which are suitable for underground usage (e.g. E-YY-J) may be used.
- In case that special regulations require another type of cable, cables according to these regulations have to be used.

Mounting dimensions TPS 20 (in mm)

- (1) Ground plate
- (1a) Cable inlet
- (1b) Slotted holes (4x) for connection on the ground
- (2) Gear wheel
- (3) Emergency release
- (Z) Steel gear rack

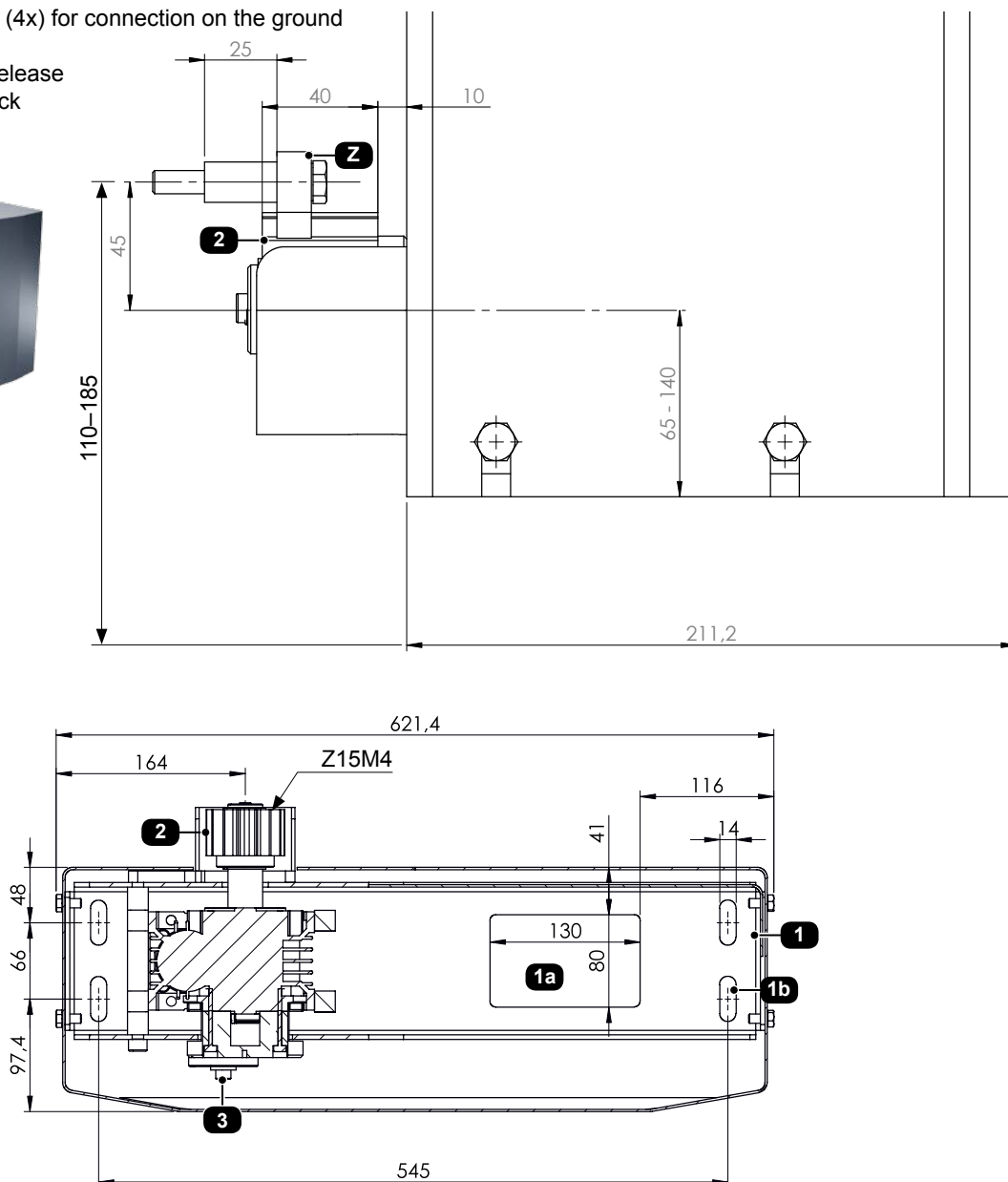

Mounting dimensions TPS 20N (in mm)

- (1) Ground plate
- (1a) Cable inlet
- (1b) Slotted holes (4x) for connection on the ground
- (2) Gear wheel
- (3) Emergency release
- (Z) Steel gear rack

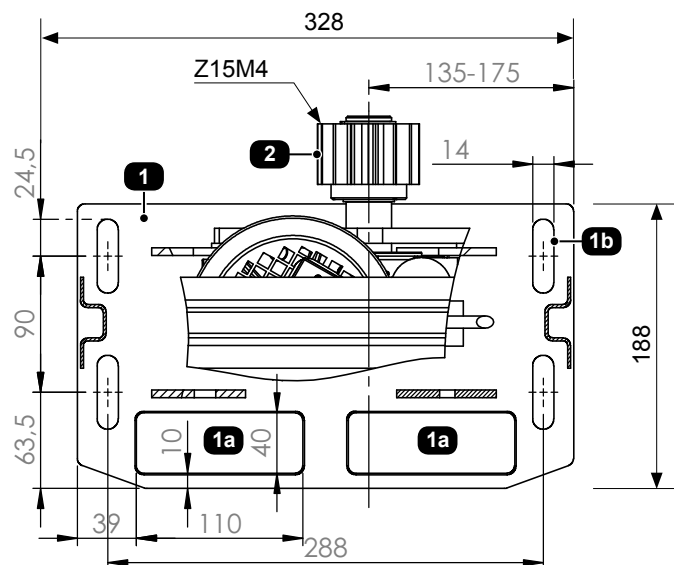
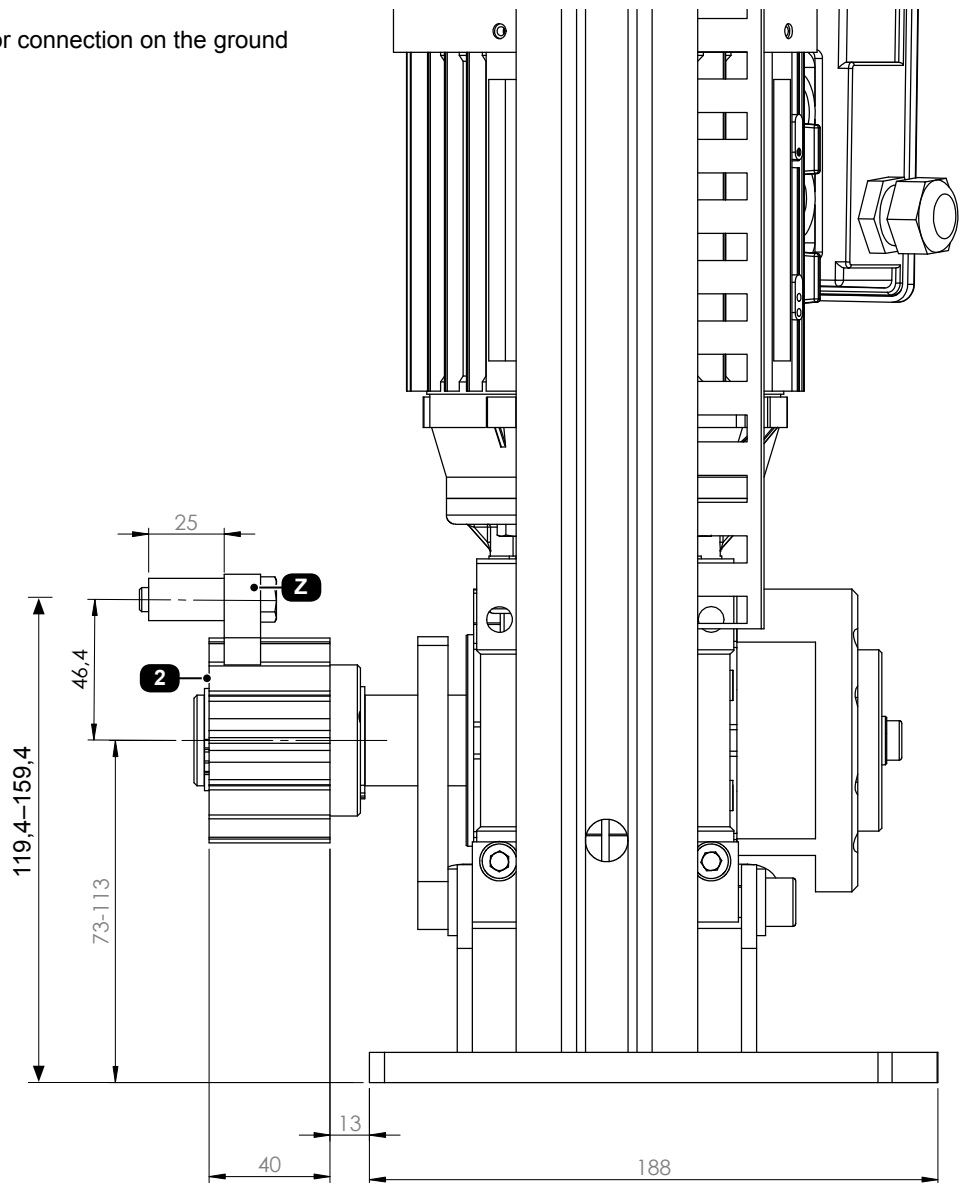

Mounting dimensions TPS 20 PRO (in mm)

- (1) Ground plate
- (1a) Cable inlet
- (1b) Slotted holes (4x) for connection on the ground
- (2) Gear wheel
- (3) Emergency release
- (Z) Steel gear rack

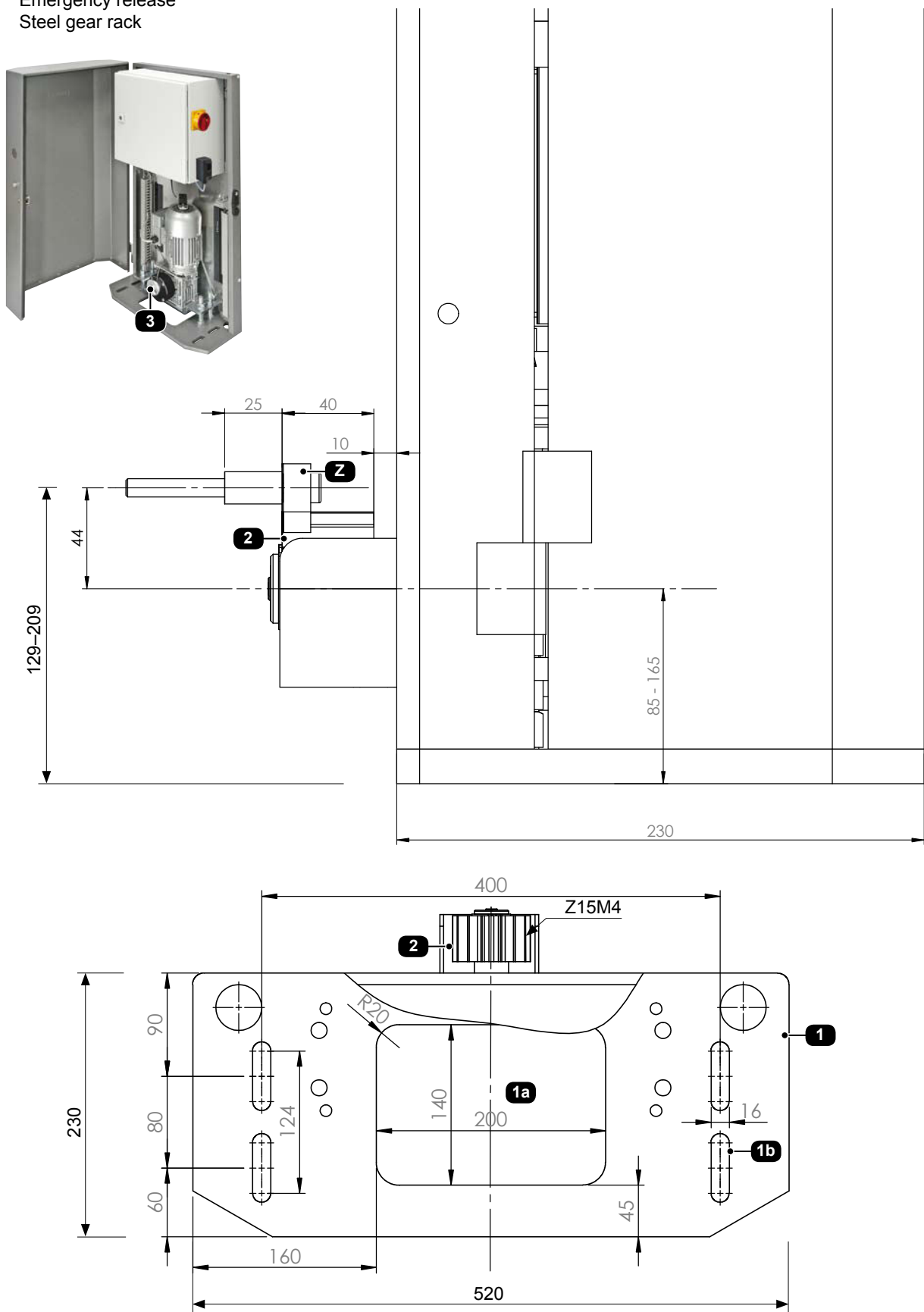

2.2 Installation of the gear rack

- Disengage the motor from the output drive pinion with the emergency release lever (see emergency release for instructions) and open the gate completely.
- Install the spacer tubes (D) with the help of the bolts and washers on the first meter of gear rack
- Make sure that the bolts/screws sit in the top end of the vertical slots (L), then tighten them.
- Place the first gear rack element on the drive pinion and fix it in place with a screw clamp.
- Move the gate by hand until reaching the end of the first gear rack element, then weld the first, second, and third spacer tube to the gate
- Proceed with the other gear rack elements in the same manner.
- **Before fixing the second meter of gear rack it is essential to place another gear rack element under the first and second gear rack elements, thereby making sure that the gearing module between the two gear rack elements will be exactly kept (see illustration).**
- After installation of the gear rack please loosen the fastening bolts slightly and rise the gear rack a little along the vertical slots, creating a **vertical distance of approx. 1 mm between the drive pinion of the operator and the gear rack.**
- The gear rack elements can also be installed without welding, i.e. by screwing them to the gate frame together with the spacer tubes. Apart from that the gear rack elements have to be installed in the same manner.

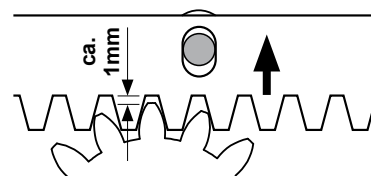
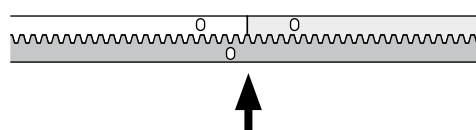
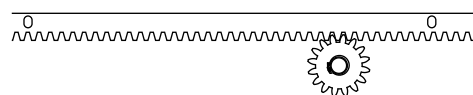
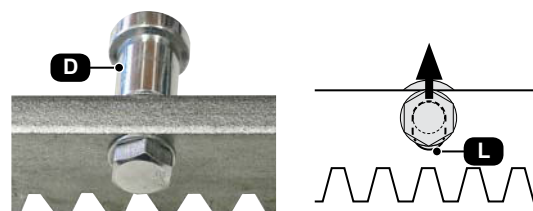

Attention

- Do not weld the individual gear rack elements together!
- With a gate weight of >1000 kg we recommend using racks in a wider version.

2.3 Dismantling

The dismantling of motor is made the other way around of mounting.



Before dismantling please plug off power supply of motor !

Overview of the control unit



Attention

After connection, the wires have to be fixed with binders. This should prevent a 230V line from getting in contact with a low voltage line, in case that a wire loosens itself from the terminal

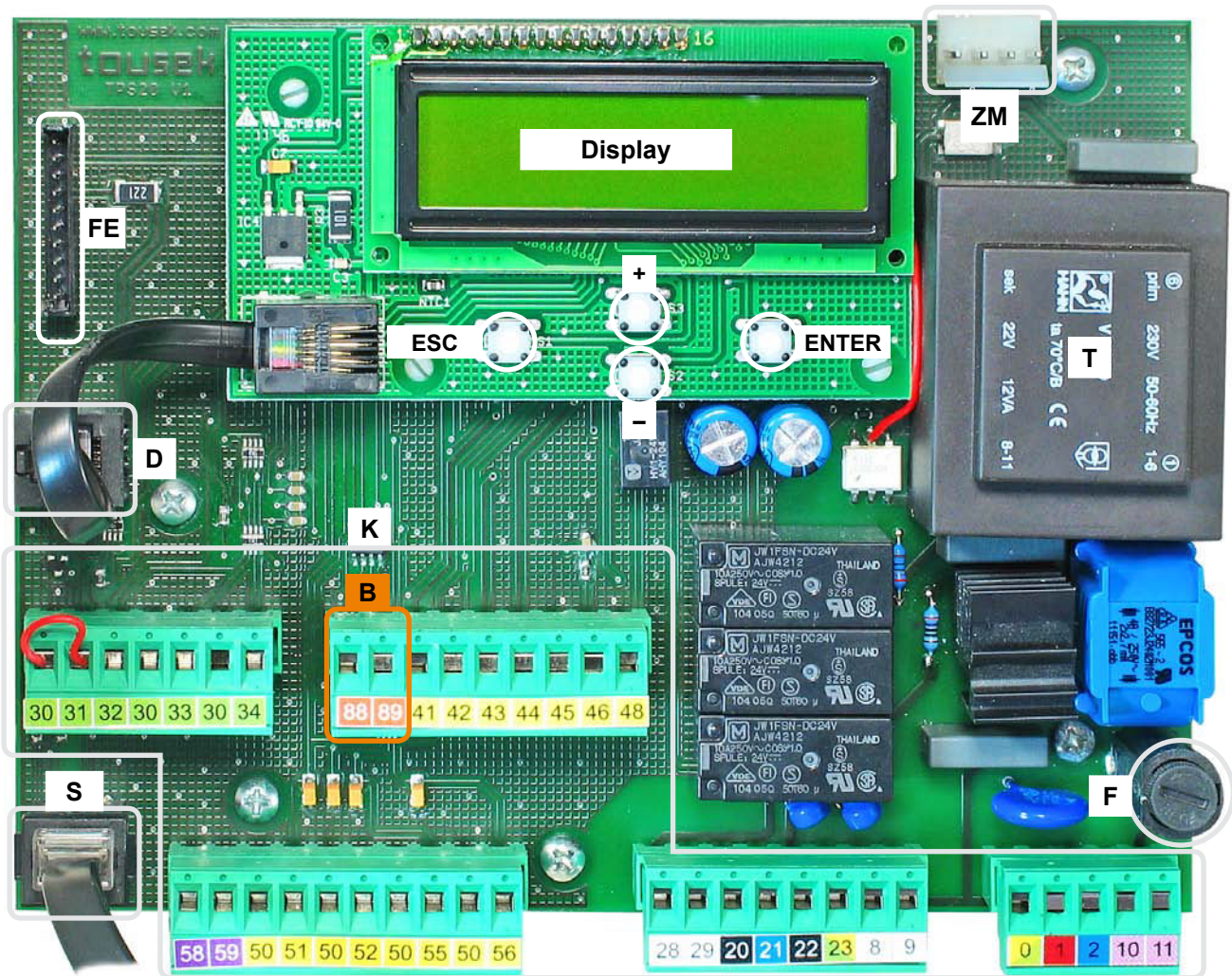

Important

The optional tousek- service-interface must be connected with socket (D) !



Elements of control board

- (K) Terminal blocks
- (B) bus system terminals 88/89 (connection with optional traffic light control)
- (S) Sensor plug
- (D) Display plug or connection with optional tousek-service-interface (TSI)
- (FE) Slot for optional radio receiver (see page 30 for connection)
- (ZM) Connection slot for optional module (see page 26)
- (F) Primary fuse T 6,3A
- (T) Transformer

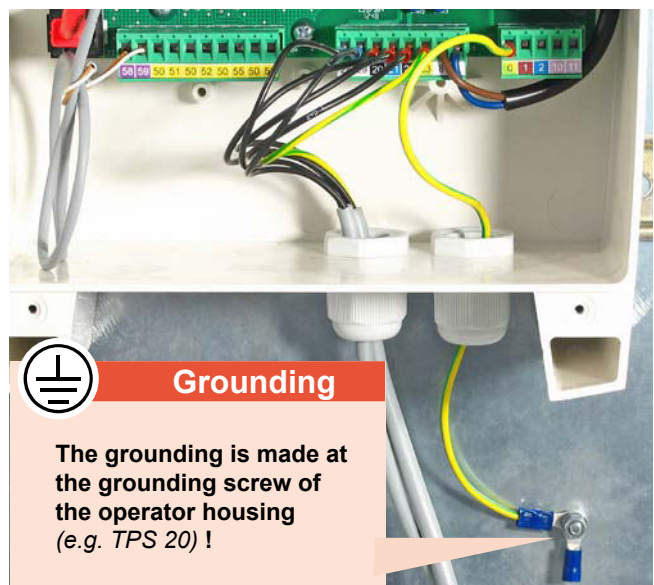

Grounding

The grounding is made at the grounding screw of the operator housing (e.g. TPS 20) !



Warning notes

- Before taking off the control cover, the main switch must be turned off!
- If the control is power supplied, its inner part is under tension.
- In order to avoid electrical strokes, the safety regulations have to be kept.
- The device may only be connected by trained professionals.



- The product is not suitable for installation in explosion-hazardous areas.
- An all-pole disconnecting main switch with a contact opening gap of min. 3 mm has to be foreseen. The gate facility has to be secured according to the valid safety regulations!
- **IMPORTANT:** The control lines (buttons, radio, photocells, etc.) have to be laid separately from the 230V lines (supply line, motors, signal lamp).



If no stop switch is connected, terminals 30/31 have to be wire-bridged (the jumper is set in the factory).

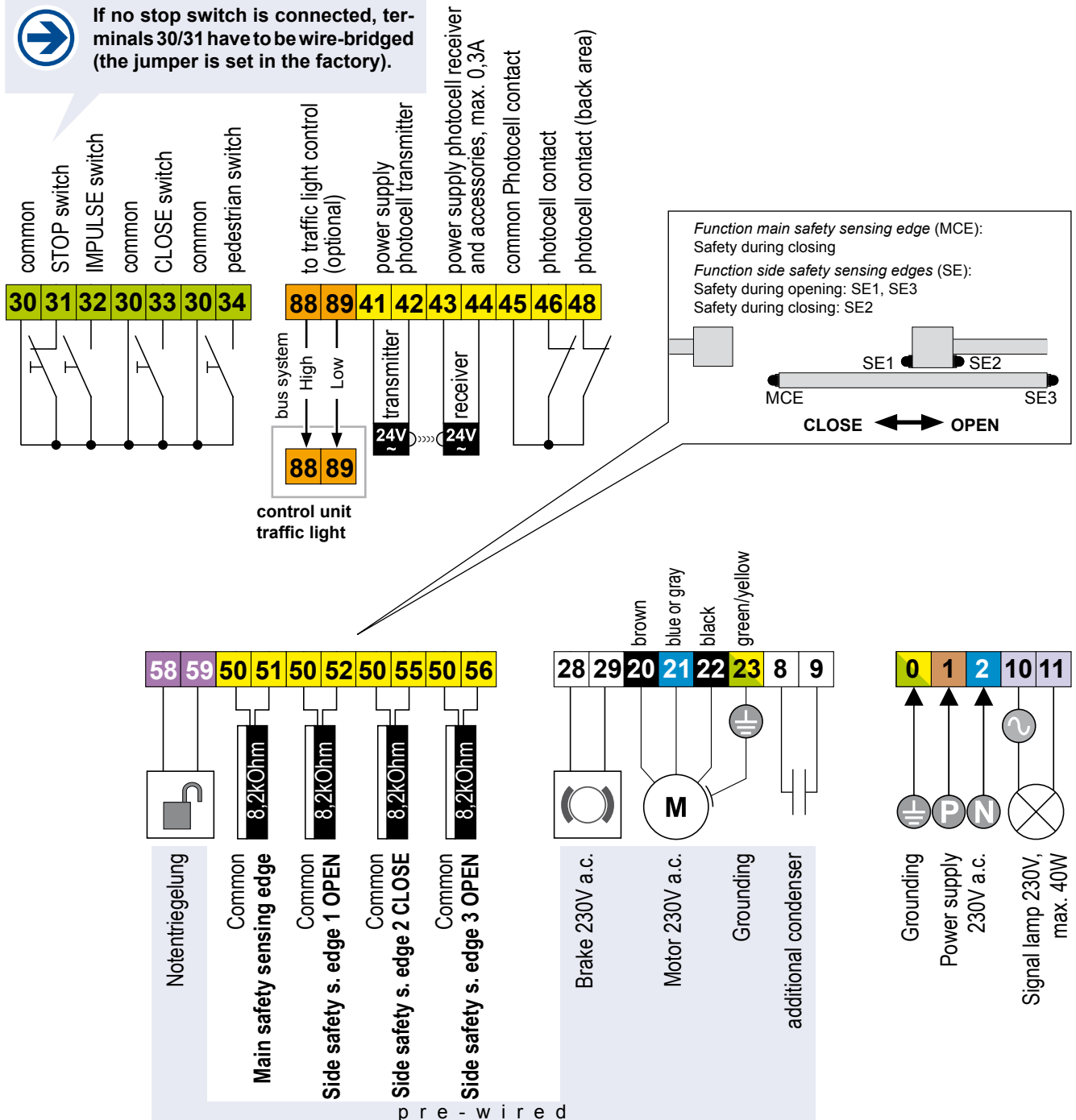

- During connection, adjustment and maintenance works please take care, that the electronic circuit board won't be damaged by moisture (rain).



Warning notes

- Before opening the control box, the main switch must be turned off!
- If the control is power supplied, its inner part is under tension.
- In order to avoid electrical strokes, the safety regulations have to be kept.
- The device may only be connected by trained professionals.



- The product is not suitable for installation in explosion-hazardous areas.
- An all-pole disconnecting main switch with a contact opening gap of min. 3 mm has to be foreseen. The gate facility has to be secured according to the valid safety regulations!
- **IMPORTANT:** The control lines (buttons, radio, photocells, etc.) have to be laid separately from the 230V lines (supply line, motors, signal lamp).

Overview of the control box

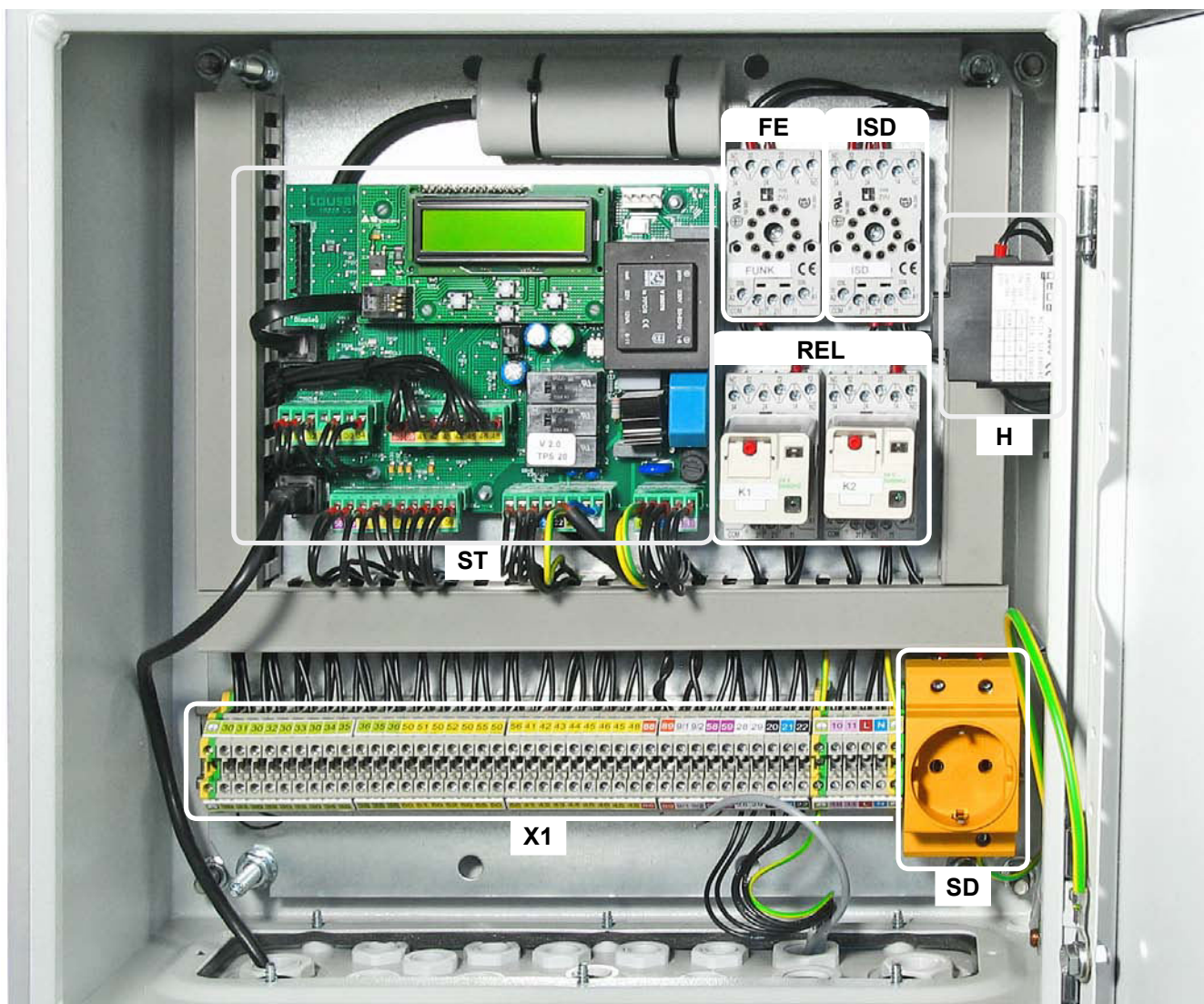

Elements of control box

- (ST) Control board (see p. 12)
- (FE) Socket for radio receiver (see p. 29)
- (ISD) Socket for induction loop detector (see p. 29)
- (REL) Decoupling relay
- (H) Main switch
- (SD) 230V Schuko socket
- (X1) Terminal block



Unlike the operators TPS 20, -20N the TPS 20 PRO has an additional terminal block X1. All connections have to be done at this block, which is internally connected with the control board ST.

Programming buttons

Adjustments - overview



- The adjustment (programming) of the operating parameters is carried out with four programming buttons and the display.
- Before starting the programming, please choose the language. Use the buttons **+** or **-** to choose menu language and confirm with **ENTER**.
- **Note: Language selection can also be chosen by pressing the ESC button for 5s, from any position in menu.**

- The text display informs about behaviour, chosen menus and adjustment of different settings.
- The programming of the control is carried out with the help of four buttons (**+**, **-**, **ENTER** und **ESC**).
- Scrolling through the available menu points (up/down) or the adjustment of a parameter (value increase/decrease) is carried out with buttons **+** and **-**.
AUTO-COUNT: when holding one of the buttons the value changes automatically.
- When pressing the **ENTER**-button a confirmation for entering the shown menu point, resp. for accepting the shown value of a parameter is given.
- When pressing the **ESC**-button you return to the superior menu point. Possibly changed adjustments of a parameter are rejected with this button (the former values will remain).
- **AUTO-EXIT:** if no button is pressed during 1 min. then the menu switches automatically to the "ready" menu (without saving changed parameters)

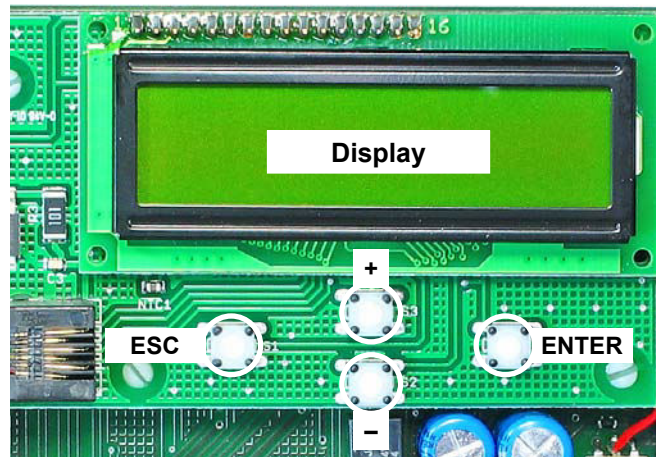

Programming menu

Adjustments - overview



- The program menu is divided into "BASIC SETTINGS" and "MENU CONTROL"

BASIC SETTINGS

- **When entering the programming of the control unit for the first time you will see the BASIC SETTINGS (see page 31)**
- Here the necessary adjustments which are necessary for the use of the operator/gate can be set quickly.
- For advanced settings/programming please choose the menu point "menu (control)".

MENU CONTROL

- For further programming you will reach immediately the MENU (CONTROL) (Basic settings are skipped)
- The menu control includes all kinds of settings.





The different menu points are indicated as follows:

○ = selectable settings ⊙ = factory settings ⇌ = status display













📁 shows the menu points which are in the "BASIC SETTINGS"

Menu structure

Adjustments - overview

-  - menu function appears if „traffic light“ is active.
-  - menu function appears if „traffic light“ is not active.
-  - the others appear constantly.

Note: some adjustments regarding function or operating logic can only be executed if gate is closed and if the display shows „ready“.

Main layer	Sub layer	Settings/adjustments
buttons/switches <i>see page 18</i>	impulse button	<input type="radio"/> OPEN/STOP/CLOSE <input type="radio"/> OPEN/CLOSE/OPEN <input type="radio"/> OPEN <input type="radio"/> DEAD MAN
	pedestrian func.	<input type="radio"/> partial opening <input type="radio"/> impulse OPEN
	pedestrian button	<input type="radio"/> OPEN/STOP/CLOSE <input type="radio"/> OPEN/CLOSE/OPEN <input type="radio"/> OPEN <input type="radio"/> DEAD MAN ?
	emergency mode	<input type="radio"/> not active <input type="radio"/> active
safety <i>see page 20</i>	 photocell	<input type="radio"/> active <input type="radio"/> not active
	PHC- back area	<input type="radio"/> not active <input type="radio"/> active
	PHC-function	<input type="radio"/> when closing reverse <input type="radio"/> stop - after release open <input type="radio"/> during closing stop, then close
	PHC- pause time	<input type="radio"/> no influence of photocell <input type="radio"/> abort pause time <input type="radio"/> re-start of pause time <input type="radio"/> immediate close after opening
	PHC- self test	<input type="radio"/> active <input type="radio"/> not active
safety edges <i>see page 22</i>	 Main clos. edge	<input type="radio"/> active <input type="radio"/> radio edge <input type="radio"/> TX 400 <input type="radio"/> not active
	 Side edge 1 OPEN	<input type="radio"/> active <input type="radio"/> not active
	Side edge 2 CLOSE	<input type="radio"/> active <input type="radio"/> not active
	Side edge 3 OPEN	<input type="radio"/> active <input type="radio"/> radio edge <input type="radio"/> TX 400 <input type="radio"/> not active
	SE-status display	<input checked="" type="radio"/> status display of safety sensing edges
	max. force	<input type="radio"/> 25...100% [increment 5] <input type="radio"/> = 70%
incr.start.force	<input type="radio"/> OFF, 0,5...3,0 [increment 0,5] <input type="radio"/> = 2,0	
ARS-response time	<input type="radio"/> 0,15...0,95s [increment 0,05] <input type="radio"/> = 0,50s	
speed	<input type="radio"/> 40...100% [increment 5] <input type="radio"/> = 100%	
soft way	<input type="radio"/> 0...2m [increment 0,1] <input type="radio"/> = 0,5m	
soft speed	<input type="radio"/> 30...60% [increment 5] <input type="radio"/> = 50%	
end position OPEN	<input type="radio"/> 0...-30 [increment 1] <input type="radio"/> = -5	
end position CLOSE	<input type="radio"/> 0...-30 [increment 1] <input type="radio"/> = -5	
operating mode <i>see page 24</i>	impulse mode	<input type="radio"/> Stop, start of pause time <input type="radio"/> impulse suppression when opening <input type="radio"/> pause time extension
	 opening direction	<input type="radio"/> <<<- left <input type="radio"/> ->>> right
	 operating mode	<input type="radio"/> impulse mode <input type="radio"/> automatic 1...255s [increment 5]
	partial opening automatic mode	<input type="radio"/> 10...100% [increment 1] <input type="radio"/> = 30%
	pause time logic	<input type="radio"/> no influence <input type="radio"/> always open in automatic mode
	additional module	<input type="radio"/> courtyard lamp/control lamp <input type="radio"/> status display 1 <input type="radio"/> status display 2
	traffic light	<input type="radio"/> not active <input type="radio"/> active
	only if is active the corresponding menu functions are displayed.	
lights/lamps <i>see page 27</i>	 prewarning OPEN	<input type="radio"/> OFF, 1...30s <input type="radio"/> = OFF
	 prewarning CLOSE	<input type="radio"/> OFF, 1...30s <input type="radio"/> = OFF
	 green phase	<input type="radio"/> 5...120s [increment 1] <input type="radio"/> = 20s
	 leave time	<input type="radio"/> 1...60s [increment 1] <input type="radio"/> = 5s
	 traffic gate CLOSE	<input type="radio"/> red light OFF <input type="radio"/> permanent red
	 traffic light logic	<input type="radio"/> both sides green <input type="radio"/> one side green
	courtyard lamp ¹⁾ control lamp ¹⁾	<input type="radio"/> OFF, illum. time 5...950s <input type="radio"/> = OFF <input type="radio"/> illuminates when opening/closing <input type="radio"/> blinks slowly / illuminates / blinks <input type="radio"/> illuminates in open position
diagnosis <i>see page 28</i>	status display	<input checked="" type="radio"/> status display of all inputs
	delete positions	<input type="radio"/> NO <input type="radio"/> YES
	factory setting	<input type="radio"/> NO <input type="radio"/> YES
	software version	<input checked="" type="radio"/> show software version
	serial number	<input checked="" type="radio"/> show serial number
	protocol	<input checked="" type="radio"/> show protocol notes
status sensor	<input checked="" type="radio"/> show sensor	

¹⁾ The menu points courtyard lamp and control lamp will only appear on display if in menu „Additional module“ courtyard lamp/control lamp is selected.





DIGITAL integrated control board for sliders TPS 20, -20N, -20PRO



Warning

- Before taking off the control cover, the main switch must be turned off!
- If the control is power supplied, its inner part is under tension.
- In order to avoid electrical strokes, the safety regulations have to be kept.
- The device may only be connected by trained professionals.



- The product is not suitable for installation in explosion-hazardous areas.
- An all-pole disconnecting main switch with a contact opening gap of min. 3 mm has to be foreseen. The gate facility has to be secured according to the valid safety regulations!
- **IMPORTANT:** The control lines (buttons, radio, photocells, etc.) have to be laid separately from the 230V lines (supply line, motors, signal lamp).



The different menu points are indicated as follows:

- = selectable setting ⊕ = factory settings ⇌ = status display
 [G] shows the menu points which are in the "BASIC SETTINGS"

- A general status display of all inputs can be found in the menu DIAGNOSIS / STATUS DISPLAY

Buttons / switches

Connections and adjustments

Impulse button (terminals 30/32)

Buttons/switches

- ⊕ **OPEN/ STOP / CLOSE impulse repetition** (factory settings): After a command of the impulse switch the motor starts an open or close movement. If the impulse switch is pressed again during this movement, the motor stops. With the next command, the motor drives in the opposite direction of the last gate movement.
- **OPEN / CLOSE / OPEN impulse repetition:** After a command of the impulse switch the motor starts an open or close movement. If the impulse switch is pressed again during this movement, the motor reverses.

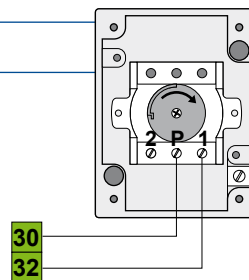

Impulse switch
(e.g key switch EPZ 1-2T)



- In this operation mode it is not possible to stop the motor with the impulse switch – it always travels until reaching an end position. (Opened or closed position).
- for the function OPEN/CLOSE/OPEN we strongly suggest the installation of a photocell!

- **OPEN:** Only open commands are accepted of the impulse switch. Closing the gate with the impulse switch is not possible.
- ➡ In traffic light mode automatically the adjustment „OPEN“ is active.

- **DEAD-MAN:** The motor opens as long as the impulse switch is pressed – closing the gate with the impulse switch is not possible. As soon as the switch is released, the gate stops. If hold to run operating mode is selected, **the radio receiver is set out of order for reasons of safety.**



IMPORTANT: Do not put into operation in dead man mode.
 Select only after putting into operation (see page 31), if desired.



As impulse emitters pushbuttons or key switches as well as external radio receivers with potential free make contacts can be used.

Pedestrian function (terminals: 30/34)

Buttons/switches

- ⊕ **Partial opening:** The contact at terminals 30/34 will be used as pedestrian button.
- **Impulse OPEN:** The contact at terminals 30/34 works as a second impulse button with the fixed adjustment „OPEN“.

Pedestrian button (terminals 30/34)

Buttons / switches

- **OPEN/ STOP / CLOSE impulse repetition:**
After a command of the pedestrian opening button the motor for pedestrian opening starts with an open- or closing movement. If the button is pressed again during this movement, the motor stops. With the next command the motor drives in the opposite direction of the last gate movement.
- **OPEN / CLOSE / OPEN impulse repetition:** after a command of the pedestrian opening button the motor starts an open or close movement. If the button is pressed again during this movement, the motor reverses.

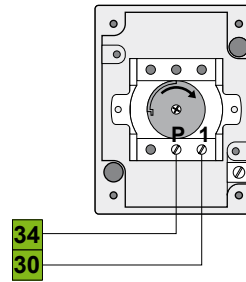

pedestrian opening button
(e.g. key switch EPZ 1-1T)



- In this operation mode it is not possible to stop the motor with the pedestrian button – it always travels until reaching an end position. (Opened or closed position).
- for the function OPEN/CLOSE/OPEN we strongly suggest the installation of a photocell!

- **OPEN:** Only open commands are accepted of the pedestrian opening button. Closing the pedestrian entry with the button is not possible.
- **DEADMAN:** The motor opens as long as the pedestrian button is pressed – closing the gate with the pedestrian button is not possible. As soon as the switch is released, the gate stops. **As soon as DEADMAN is selected, the radio receiver is without function for safety reasons.**



The DEAD MAN setting cannot be actively selected, but it gets automatically selected when the impulse button is set on DEAD MAN.



- As pedestrian button you can use pushbuttons or key switches as well as external radio receivers with potential free make contacts can be used.
- ➡ In traffic light mode the pedestrian button is without function.

CLOSE-button (terminals 30/33)

Buttons / switches

- A command with the CLOSE-switch engages closing of gate. In deadman mode the gate closes as long as the CLOSE-switch is pressed/switched. As soon as switch is released the gate movement stops.



- As CLOSE-buttons you may use pushbuttons or key switches as well as external radio receivers with potential free make contacts can be used.
- ➡ In traffic light mode the CLOSE button is without function.

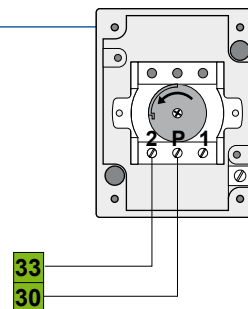

CLOSE-button
(e.g. key switch EPZ 1-2T)

STOP-switch (terminals 30/31)

Buttons / switches

- when pressing the stop switch the gate stops in any desired position.



Important



If no stop switch is connected, terminals 30/31 have to be wire-bridged.

As stop switch a break contact has to be used.

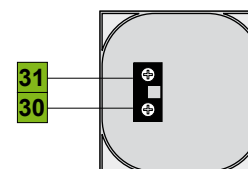

STOP-button
(e.g. switch KDT-1N)

Emergency mode

Buttons / switches

- **not active**
- **active:** In case of malfunction of the safety devices, the gate can be opened with reduced speed in DEAD MAN mode by means of the impulse button, and it can be closed by means of the CLOSE button. By pressing the respective button for 5s, you enter the emergency mode. The door will keep moving as long as the button will be pressed.
- ➡ In traffic light mode or if the impulse button is set to „DEAD-MAN“ the emergency mode is **not** active.



Important: Photocells notes

- The control unit has a power supply connection for a 24V a.c. photocell (LS):
supply LS-transmitter: terminals 41/42 / supply LS-receiver: terminals 43/44
Note: in „gate closed“ position the terminals 41/42 are being switched into energy saving mode (no current) (only, if no TX 310 system is used) !
 - The contact has to be closed when using powered and positioned photocells (opening contact).
Connection of the photocell contact: terminals 45/46, photocell back area contact: terminals 45/48
 - When using two pairs of photocells please do not install both photocell transmitters/receivers on the same side (to eliminate interference between both) !
- Standard:**

With SYNC-function:

Exception: photocells with SYNC function allow the installation of both photocell transmitters/receivers on the same side without causing interference to each other.
- **Photocell self-test function:** The control board is equipped with a self-test function for the connected photocell. With an opening impulse (switch or button) the transmitter of the photocell is switched off for a short time in gate position „closed“ . Thus the photocell receiver interrupts the contact 45/46 and 45/48 (PHC- back area) - so the control board verifies the function of the photocell receiver. If this short interruption at the photocell input is not carried out, the control board reports an error. **The deactivation of the self-test function is only allowed if the safety installations correspond to the category 3 !**
 - The exact function of the photocells depend on the programming of the control unit.
Photocell function please see menu point SAFETY / photocell function or photocell with pause time
 - **you will find detailed information in the corresponding photocell manual.**

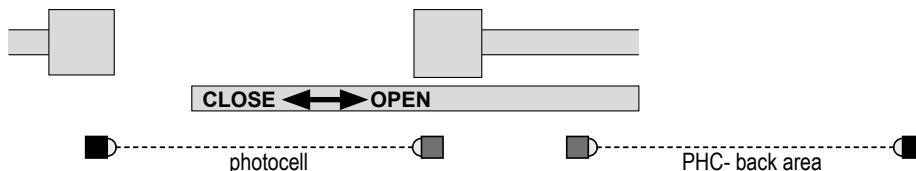

☞ Photocell (contact: terminals 45/46)

Safety

- ☉ **active:** to be selected, if photocell should be triggered.
- **not active:** to be selected, if photocell should not be triggered..

■ PHC- back area (contact: terminals 45/48)

Safety

- ☉ **not active:** No monitoring by PHC-back area.
- **active:** To be selected, if the back area of the gate has to be protected by a photocell during the opening movement. An interruption of the photocell during the opening movement causes the motor to get stopped and remain stopped as long as the photocell is interrupted. After releasing the photocell, the gate opens.

■ PHC-function (only photocell at terminals 45/46 is concerned)

Safety

- ☉ **when closing reverse:** an interruption of the photocell during closing makes the gate reverse (open). In automatic mode the gate closes as soon as the pause time has run out. In impulse operation another closing command has to be given.
- **stop, after release open:** an interruption of the photocell beam during opening or closing makes the motor stop as long as the photocell stays interrupted. After release of the photocell, the gate opens. In automatic mode the gate closes as soon as the pause time has run out, in impulse operation another closing command has to be given.
- **during closing stop then close:** an interruption of the photocell during closing makes the motor stop as long as the photocell stays interrupted. After release of the photocell, the gate closes.





PHC- pause time (only photocell at terminals 45/46 is concerned)

Safety

- **no influence of photocell:** the photocell doesn't have any influence on the pause time in automatic mode.
 - **abort pause time:** in automatic mode an interruption of the photocell during pause time shortens the pause time. After release of the photocell the gate starts closing.
 - **restart pause time:** in automatic mode an interruption of the photocell during pause time, restarts the pause time. As soon as the pause time has run out, the gate closes.
 - **immediate close after opening:** If the photocell is interrupted during the opening movement or in position open, the gate starts closing as soon as it reached end position open after release of the photocell.
- ➡ In traffic light mode only the adjustments „no influence“ and „after opening close immediately“ are available.

PHC- self test

Safety

- **active:** photocell self-test is executed with an opening impulse (switch, button) in gate position „closed“.
- **not active:** photocell self-test is not executed.



Attention

- The photocell self-test can only be deactivated by selecting „not active“.
- The deactivation of the self-test function is only permitted if the safety installations correspond to the category 3 !

Photocell - connection examples

Back area photocell Tousek LS 45/2 as safety device

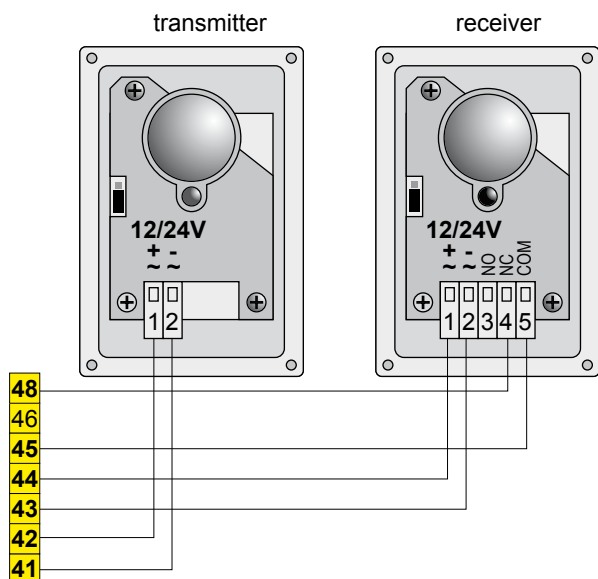

2 Photocells Tousek LS 45/2 as safety device

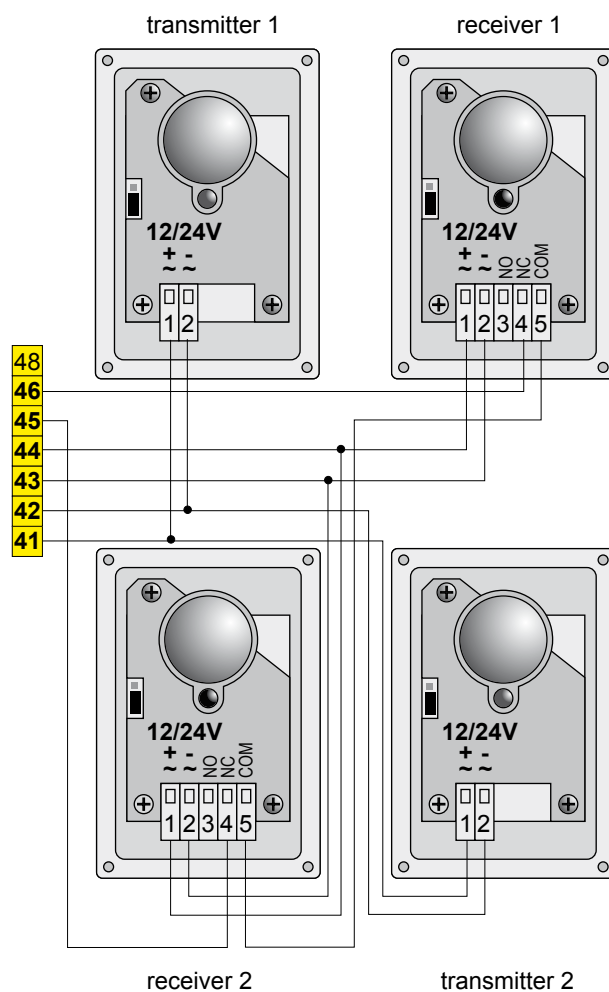

Important

- as the LS 45/2 has no SYNC-function, both photocell transmitters and receivers must be mounted on different sides!



Safety sensing edges (main and side edges)

• **OBSTACLE DETECTION:**

When a contact strip is triggered/activated then a change of direction is effected for 1 second. After that the gate continues to move in the changed direction.

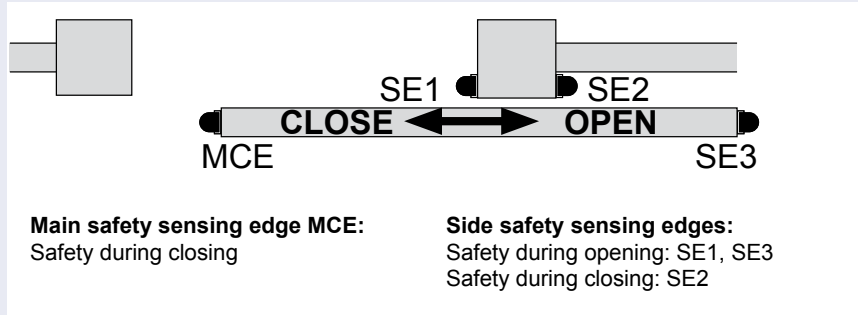

Main safety sensing edge
Side safety sensing edges

If more safety sensitive edges are required, as shown in the figure above, (e.g. second guide column), these have to be connected in series to the respective terminals SE1 and SE2.

Example: W 8,2kΩ final resistance
1 final edge
2+3 passage edge
S to control board

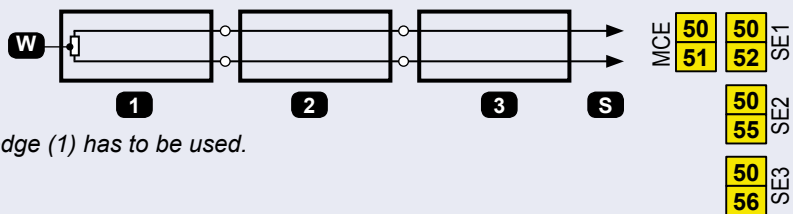

When connecting one safety edge a final edge (1) has to be used.

name in menu	short name / status display	active in direction	terminals	choice
Main clos. edge	MCE	CLOSE	50/51	<input checked="" type="radio"/> active <input type="radio"/> not active <input type="radio"/> radio edge TX <input type="radio"/> TX 400
Side edge 1 OPEN	SE1	OPEN	50/52	<input checked="" type="radio"/> active <input type="radio"/> not active
Side edge 2 CLOSE	SE2	CLOSE	50/55	<input checked="" type="radio"/> active <input type="radio"/> not active
Side edge 3 OPEN	SE3	OPEN	50/56	<input checked="" type="radio"/> active <input type="radio"/> not active <input type="radio"/> radio edge TX <input type="radio"/> TX 400

Main closing edge (terminals 50/51)

Safety edges

- ⊙ **active:** to be selected if the contact strip (8,2kOhm) of main closing edge should be evaluated.
- **Radio edge:** to be selected if the contact strip (8,2kOhm) of main closing edge should be evaluated **with the radio transmission system TX 310.**
- **TX 400:** to be selected if if the contact strip (8,2kOhm) of main closing edge should be evaluated **with the system TX 400i.**
- **not active:** to be selected if the contact strip (8,2kOhm) of main closing edge should NOT be evaluated

Side edge 1 OPEN (terminals 50/52)

Safety edges

- ⊙ **active:** to be selected if the contact strip (8,2kOhm) of side edge 1 OPEN should be evaluated.
- **not active:** to be selected if the contact strip (8,2kOhm) of side edge 1 OPEN should NOT be evaluated.

Side edge 2 CLOSE (terminals 50/55)

Safety edges

- ⊙ **active:** to be selected if the contact strip (8,2kOhm) of side edge 2 CLOSE should be evaluated.
- **not active:** to be selected if the contact strip (8,2kOhm) of side edge 2 CLOSE should NOT be evaluated.

Side edge 3 OPEN (terminals 50/56)





Safety edges

- ⊙ **active:** to be selected if the contact strip (8,2kOhm) of side edge 3 OPEN should be evaluated.
- **Radio edge:** to be selected if the contact strip (8,2kOhm) of side edge 3 OPEN should be evaluated **with the radio transmission system TX 310.**
- **TX 400:** to be selected if the contact strip (8,2kOhm) of side edge 3 OPEN should be evaluated **with the system TX 400i**
- **not active:** to be selected if the contact strip (8,2kOhm) of side edge 3 OPEN should NOT be evaluated

SE-status display

Safety edges

- ⇒ Status display of safety sensing edges
- | | | | |
|------------|-------------------|------------|-------------------|
| MCE | main closing edge | SE2 | side edge 2 CLOSE |
| SE1 | side edge 1 OPEN | SE3 | side edge 3 OPEN |

-  status: okay
-  status: not okay or triggered
-  status: safety sensing edge interrupted
-  status: not activated

e.g.

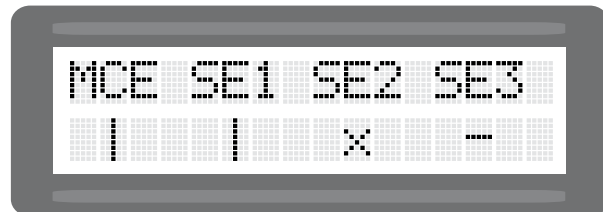

Important

- During programming of motor the contact safety edges should not be triggered as this leads to an error message - the limit stops have to be placed correspondingly.



Radio transmission system TX 310

- Connection and detailed information of radio transmission system TX 310 see according manual..



Inductive system TX 400i

- Connection and detailed information of inductive system TX 400i see according manual..

Max. force ☉ 70% (factory setting) Motor

- 25–100% adjustable [increment 5]: determines the max. possible motor force.

Increased starting force ☉ 2,0 (factory setting) Motor

- OFF, 0,5–3,0 adjustable [increment 0,5]: determines the increased starting force.

ARS response time ☉ 0,50s (factory setting) Motor

- 0,15–0,95s adjustable [increment 0,05]: determines, in which time the AR-System responds. The lower the value, the more sensitive the sensor will react.

Speed ☉ 100% (factory setting) Motor

- 40–100% adjustable [increment 5]: determines the speed of motor.

Soft way ☉ 0,5m (factory setting) Motor

- 0–2m adjustable [increment 0,1]: determines the distance of soft run.



soft start fixed: approx. 1s

Soft speed ☉ 50% (factory setting) Motor

- 30–60% adjustable [increment 5]: determines the speed during soft run. If the entered value for soft speed is higher than normal speed the value will be rejected and automatically set to a value that is 5% below the set value for normal speed.

End position OPEN ☉ -5 (factory setting) Motor

- 0...-30 adjustable [increment 1]: for readjustment of the automatically detected OPEN limit position of gate (e.g. for safety sensing barriers). With adjustment 0 the motor runs to the previously learned open position. For a diminished drive distance the value can be extended to up to -30.

This adjustment is ONLY adopted in CLOSED-position.

End position CLOSE ☉ -5 (factory setting) Motor

- 0...-30 adjustable [increment 1]: for readjustment of the automatically detected CLOSE limit position of gate (e.g. for safety sensing barriers). With adjustment 0 the motor runs to the previously learned close position. For a diminished drive distance the value can be extended to up to -30.

This adjustment is ONLY adopted in CLOSED-position.

**Attention**

With force adjustment the valid safety regulations and standards have to be strictly followed !

Operating mode

Connections and adjustments

Impulse mode Operating mode

- **stop (at opening) - start of pause time:** An impulse during the opening movement stops the gate and starts pause time in automatic operation. When the pause time has run out, the gate closes automatically.
- **impulse suppression when opening:** Commands received during the opening movement are suppressed, commands during closing are accepted.
 - ☺ In traffic light mode automatically the adjustment „impulse suppression“ is active.
- **pause time extension:** A command during pause time restarts the pause time. If this menu point is chosen, an impulse suppression during opening is active at the same time.

Opening direction Operating mode

- <<<< **left:** gate opens to the left side (seen from inside)
- >>>> **right:** gate opens to the right side (seen from inside)

This adjustment is ONLY adopted in CLOSED-position.

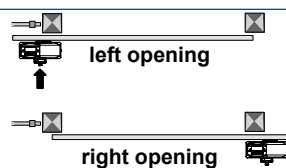
**Operating mode** Operating mode

- **Impulse mode:** Impulse through impulse switch/button or CLOSE-button to start closing of gate.
- **Automatic mode, pause time 1-255s adjustable [increment 5]:** gate closes automatically after the adjusted pause time.





Partial opening \odot 30% (factory setting)

Operating mode

- \odot **10–100% adjustable [increment 1]:** value defines the partial opening based on the total opening.

This adjustment is ONLY adopted in CLOSED-position.

Automatic mode

Operating mode

- \odot **complete/partial opening:** either with complete as well as partial opening, the gate closes automatically after the adjusted pause time.
- \odot **only complete opening:** only after complete opening, the gate closes automatically after the adjusted pause time.
- \odot **only partial opening:** only after partial opening the gate closes automatically after the the adjusted pause time.

Pause time logic

Operating mode

- \odot **no influence**
- \odot **always open in automatic mode:** if this function is activated, the control unit goes from automatic mode into impulse mode **with activated pause time through impulse in open gate position for this cycle**, hence if gate is open then an impulse will end the automatic mode - the gate remains open. Only the next impulse will close the gate and the control unit goes back to automatic mode. With this function e.g. the entrance to a company site can remain open during the day (1st impulse in gate open position) and closed in the evening (2nd impulse). The control board switches back to automatic mode (autom. opening and closing of gate).

Additional module

Operating mode

- \odot **courtyard lamp/control lamp:** the menu points courtyard lamp and control lamp are ready for adjustment and Control lamp zur Einstellung bereit (that means if not selected, these menu points will not be shown on the display)

- \odot **status display 1:** with the two potential-free signal contacts K1 and K2, the gate end positions (limits) can be evaluated.

- \odot **status display 2:** with the two potential-free signal contacts K1 and K2, the gate end positions (limits), the gate movement as well as a gate stop outside of the end positions can be evaluated.

		Function	K1	K2
Gate status display 1	1	Gate in CLOSE-Position	1	0
		Gate in OPEN-Position	0	1
Gate status display 2		Gate in CLOSE-Position	0	0
		Gate opens or closes	0	1
		Gate stopped or fault (Gate not in end position)	1	0
		Gate in OPEN-position	1	1

0 = signal contact open, 1 = signal contact closed



Only if an additional module (see page 26) is installed you can carry out one of these adjustments (courtyard-/control lamp hence gate status 1 or 2).

Traffic light

Operating mode

- \odot **not active**
- \odot **active:** Traffic light function active

- With the optional traffic light control unit, that has to be connected to the bus terminals (B): term: 88, 89 (see picture at page 34), you can implement a traffic light operation mode.
- **Note: The functions and settings relevant for the traffic light operation are displayed in the menu only after selecting "active"** → see 
- Connection of the traffic light -> see instruction manual of the traffic light control unit



Additional module (optional) Courtyard lamp/control lamp hence gate status display

- The use of one of the additional modules is optional.
- Depending on which device, e.g. a courtyard-/Control lamp is chosen or evaluation of gate status should be effected, the corresponding module has to be plugged to the according slot/plug of control board.
- Additionally the corresponding value has to be selected in menu point „Additional module“

Connecting an additional module

- turn off power supply !
- Plug additional module (Z) onto the slot (ZM).

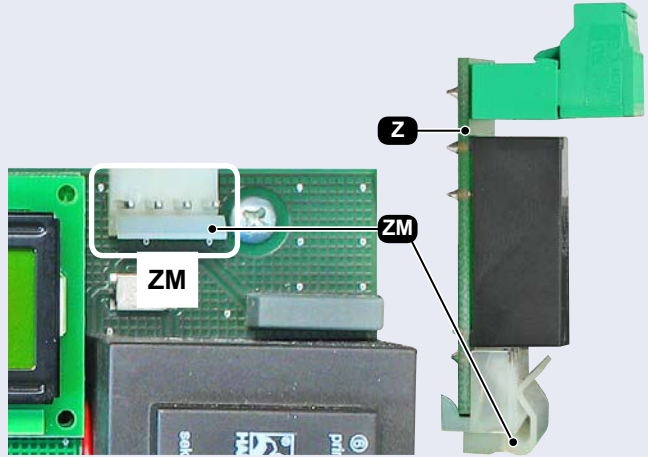

Additional module Courtyard lamp/Control lamp

- On the terminals 12/13 a courtyard lamp (H) can be connected: **230V, max. 100W**
- On the terminals 70/71 a control lamp (K) can be connected: **24Vd.c., max. 2W**

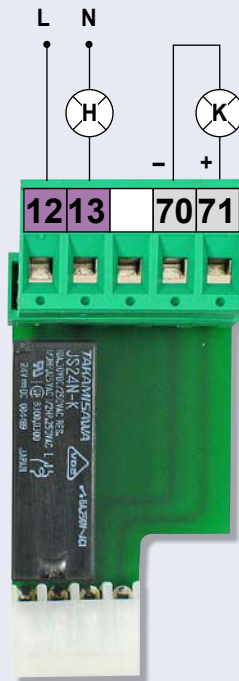

Additional module Gate status display

- with potential free signal contacts K1 (term. 90/91) and K2 (term. 92/93) the gate status can be evaluated in two ways (see menu point „Additional module“).
- Contact load: **24Va.c./d.c., max. 10W**

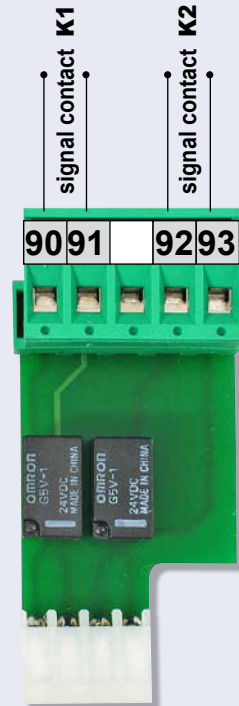

**Warning**

- Before connection works please turn off the main power switch !
- Safety rules please see page 13 !

**Prewarning OPEN** (Signal lamp:terminals 10/11)

Lights / Lamps

- ⊙ **switched off**
- **1–30s adjustable:** Before each opening movement the signal lamp/ flashing light is activated for the adjusted time.

**Signal lamp**

- a signal lamp can be connected to the terminals 10/11 (230V, max. 100W).

**Prewarning CLOSE** (Signal lamp: term. 10/11) 

- ⊙ **switched off**
- **1–30s adjustable:** Before each closing movement the signal lamp/ flashing light is activated for the adjusted time.

Green phase ⊙ 20s (factory setting) 

Lights / Lamps

- **5–120s adjustable [increment 1]:** duration of green phase.

Leave time ⊙ 5s (factory setting) 

Lights / Lamps

- **1–60s adjustable [increment 1]:** time to leave the traffic light intermediate area.

Traffic gate CLOSE 

Lights / Lamps

- ⊙ **red light OFF:** red traffic light does not illuminate in closed position.
- **permanent red:** red traffic light illuminates also in closed position.

Traffic light logic 

Lights / Lamps

- ⊙ **same signal (both sides green):** both traffic lights illuminate in open position GREEN, regardless of which side has been given the green request.
- **differant signals (one side green):** only the traffic light illuminates in open position GREEN, from the side from where the green request has been requested.

The following two menu points can only be selected if the menu point additional menu is adjusted to „Courtyard-/Control lamp“ (hence shown on display).

Courtyard lamp (Description add. modules page 26)

Lights / Lamps

- ⊙ **switched off**
- **5–950 adjustable:** at the courtyard lamp output an external lamp can be connected (e.g. garden lamp), which can be turned on for each opening command for the duration of adjusted time.

Control lamp (Description add. modules page 26)

Lights / Lamps

- ⊙ **illuminates when opening/closing:** The pilot lamp output is activated during opening- and closing movement.
- **blinks slowly / illuminates / blinks:** The pilot lamp output is activated as follows: During opening the pilot lamp flashes slowly. During pause time, in opened position or when the gate stops it is illuminated. During the closing movement it flashes rapidly. If the gate is closed, the pilot lamp expires
- **illuminates in open position:** Pilot lamp is illuminated as soon as the gate has reached end position open.

Status display

Diagnosis

➔ Status display for inputs as photocell, stop button, impulse switch ...

- | | | | |
|------|-----------------------------|---|-------------------------------|
| I | impulse button | █ | status: okay |
| P | pedestrian entry | ▒ | status: not okay or triggered |
| C | CLOSE-button | ○ | status: not activated |
| S | STOP-button | | |
| Ph | photocell contact | | |
| Ph-B | photocell contact back area | | |

for example

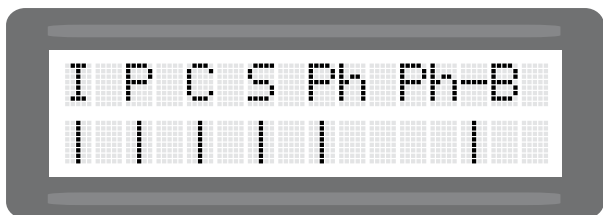

All inputs okay.

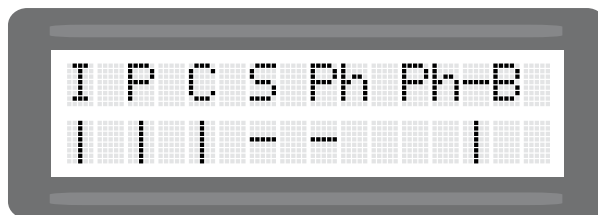

STOP button and photocell are triggered. All other inputs are okay.

Delete positions

Diagnosis

- ⊙ **NO:** does not delete the end positions "gate closed" and "gate open"
- **YES:** the determined end positions are being deleted. Note: the end positions will be determined after new impulse.



The mechanical stops have to be placed so that possibly existing safety contact edges can not be triggered, as this would lead to an error message.

Factory setting

Diagnosis

- ⊙ **NO:** no reset back to factory settings
- **YES:** reset back to factory settings



Note: The factory settings of the single menu points are marked with ⊙ in this manual.

Software version

Diagnosis

➔ shows the software version on display

Serial number

Diagnosis

➔ shows the serial number on display

Protocol

Diagnosis

➔ shows the protocol list on display: all events that take place are protocolled in this list. with the buttons + and - the single events can be seen:

With * the protocole beginning hence the end is shown

Time since the last event:
DAYS HOURS : MINUTES : SECONDS

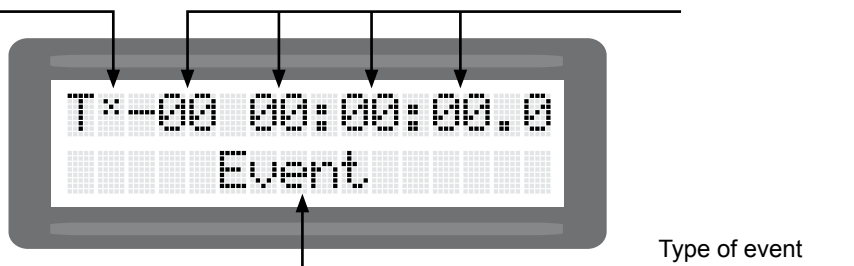

Status Sensor

Diagnosis

➔ Degree and signal strenght of rotation speed sensor is shown on display.

Decoupled Impulse switch (terminals X1: 35/36)

Other connections

- These input terminals are used for a far away impulse switch. The function is identical to the normal impulse switch input.



Decoupled „permanent open“ switch (terminals X1: 35/36)

Other connections

- The “permanent open” contact is used for e.g. fire alarm systems, weekly timers or porter signals. When the contact is closed the door opens and remains in open position (This situation can easily be detected by relay K2). If the switch is opened again the pause time in automatic mode starts. The door closes after pause time.



„Permanent open“ switch

- The adjustment of **O OPEN** in menu button-switches/ impulse button is required for the correct function. Closing of the gate with the impulse switch is not possible with this adjustment.

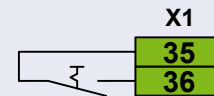

Induction loop input (terminals X1: 9/1,9/2)

Other connections

- For connecting the induction loop. The function is identical to the “permanent open” switch input.

For more information about induction loop and detector see *according manual*.

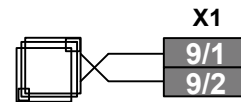

4. Sockets of TPS 20 PRO

Radio receiver and induction loop detector

Sockets of TPS 20 PRO

Radio receiver (socket FE)

- On the 11-pin socket (FE) a radio receiver (e.g. BT40SO230V, RS433SO230V or RS868SO230V) can be plugged. For a greater range use an external antenna. The function of the radio receiver is identical to the impulse switch.

Induction loop detector (socket ISD)

- On the 11-pin socket (ISD) an induction loop detector ISD5 can be plugged. The function of the detector is identical to the impulse switch.



5. Connecting the receiver (optional) at TPS 20, -20N

Sliding gate operator TPS 20, -20N

- Turn off power supply.



- Plug-in the receiver printed circuit board (E) RS433/868-STN1 (1-channel) or RS433/868-STN2 (2-channels) into the corresponding slot (FE) as shown in the picture.
- To increase the range an external antenna FK433 or FK868 can be connected.



Important

- With the use of the 2-channel-receiver the second channel takes over the function of the pedestrian entry mode switch.

With the RS 433 version a connecting cable from the terminals of the receiver board to the pedestrian button input of the control unit is required.

- For programming of receiver please *see manual for radio receiver*.

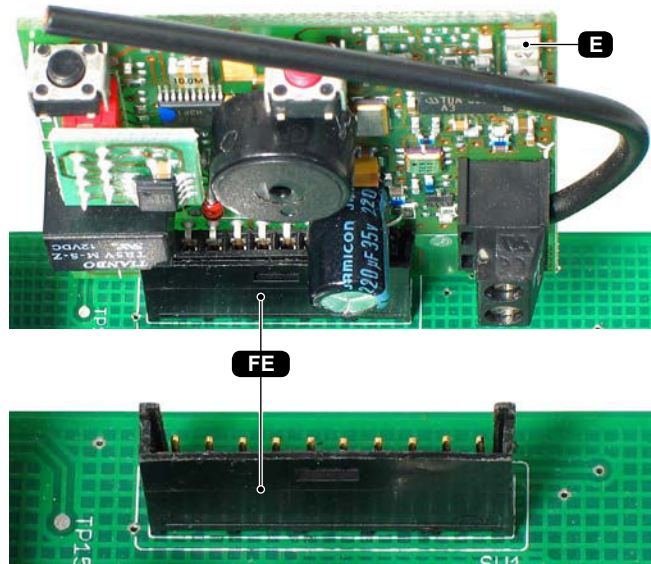
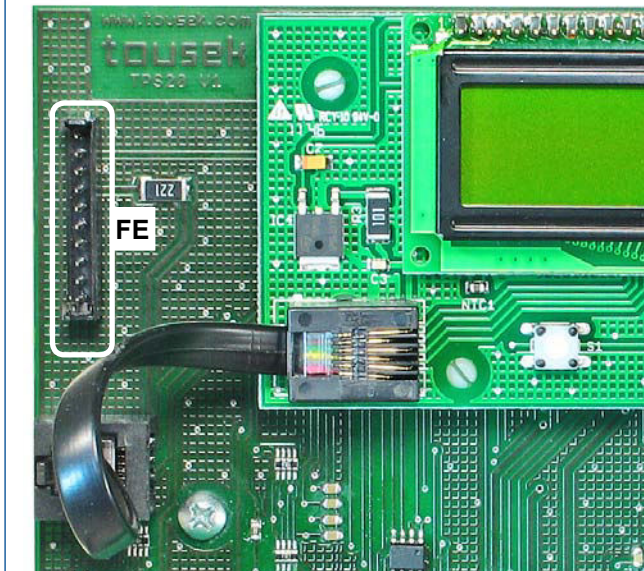

Important notes after installation

- Installation, connection, adjustments, putting into operation, and servicing may only be carried out by trained professionals in full accordance with these installation- and operating instructions.
- The packaging materials (cardboard, plastic, EPS foam parts and filling material etc.) have to be properly disposed of in accordance with the applying recycling and environmental protection laws. They may be hazardous to children and therefore have to be stored out of children's reach.
- The product is not suitable for installation in explosion-hazardous areas.
- The product may only be used in accordance with its original purpose, for which it has been exclusively designed, and which is described in these installation and operating instructions (especially children have to be instructed). The TOUSEK Ges.m.b.H. rejects any liability if the product is used in any way not fully conforming to its original purpose as stated herein.
- All electrical installations have to be made in full conformity with the applying rules and laws (e.g. using a fault current circuit breaker, proper grounding etc.).
- An all-pole disconnecting main switch with a contact opening-gap of minimum 3 mm has to be foreseen.
- The electric motor heats up during operation. Therefore the device should only be touched after it has cooled off.
- After installation the proper function of the gate facility and the safety devices has to be checked!
- The installer has to inform the user about all aspects of the automatic operation of the complete gate facility, as well as about emergency operation. The installer further has to supply to the user all instructions relating to the safe operation of the gate facility. The installation and operating instructions also have to be handed over to the user.

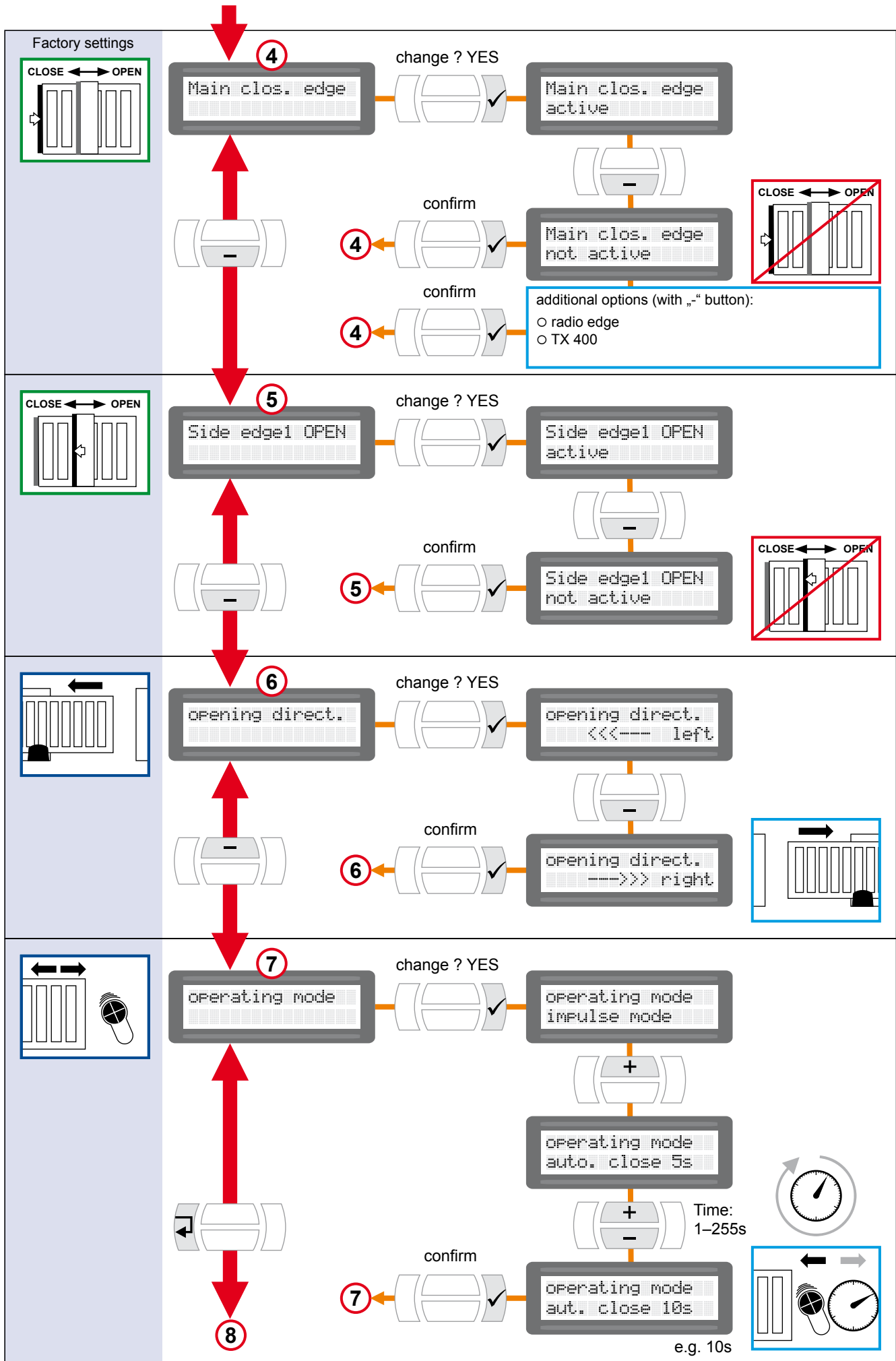

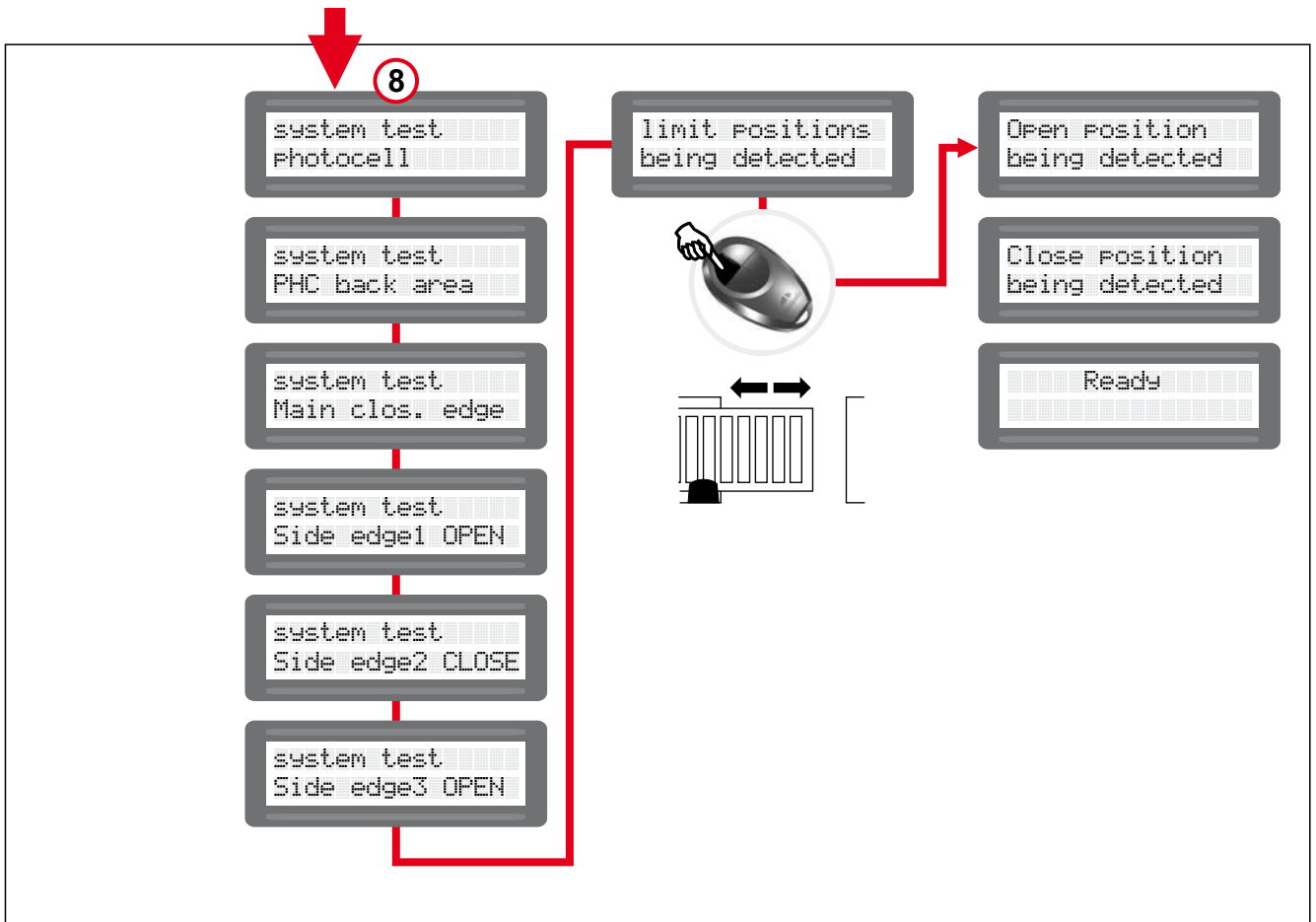

7. Emergency release in case of power failure (note for the user)

TPS 20, -20N, -20PRO

In case of a power failure or other defect the drive pinion can be disengaged from the gearmotor as follows:

- **Switch off power supply !**



- Turn the lock cover (A) in counter-clockwise direction, until the emergency release key can be inserted. Now turn the key (S) to the left and up to the stop (anti-clockwise), until you hear a click and it reaches the unlocked position.
- Now the gate can be opened and closed by hand.

*Re-engaging the emergency release mechanism:
To return to normal motor operation please turn back the key to its original position.*



Important

- **After the key has been turned back, slowly move the gate manually in its travel direction until you can hear that the gearing has re-engaged!**

Remove the key afterwards.

With next command the motor searches the open position (a new learning of end positions is not necessary).

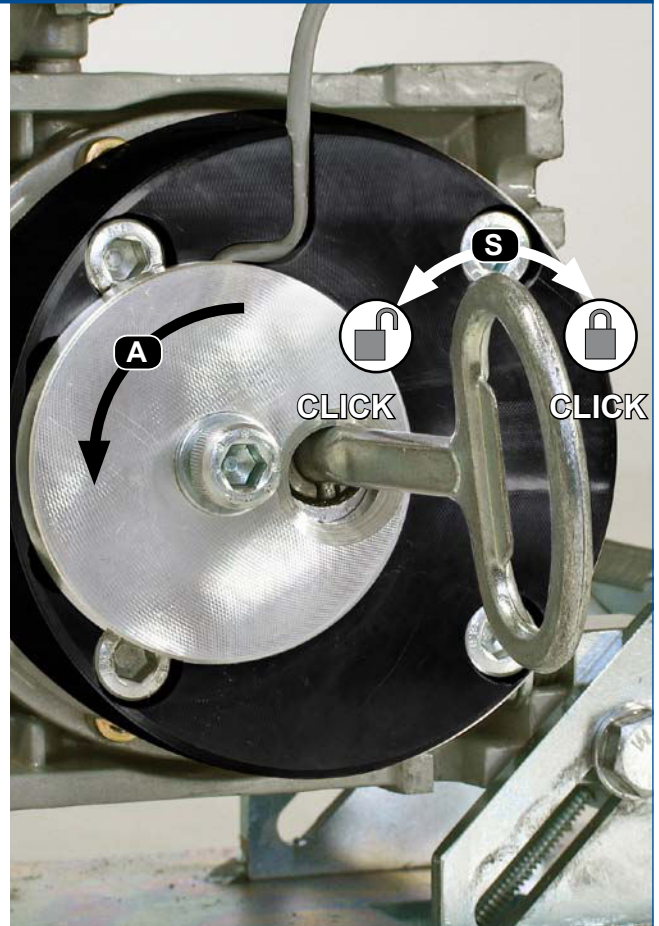

Traffic light control board STA 11

- Connection possibility of two impulse switches or induction loops for Green request and two Red/Green traffic lights 230V, 60W (inside and outside).
- Connection slots for optional radio receiver and induction loop detector
- **CE**

Traffic light control STA in housing IP 54 (210 x 310 x 125mm)



Operator control board TPS 20

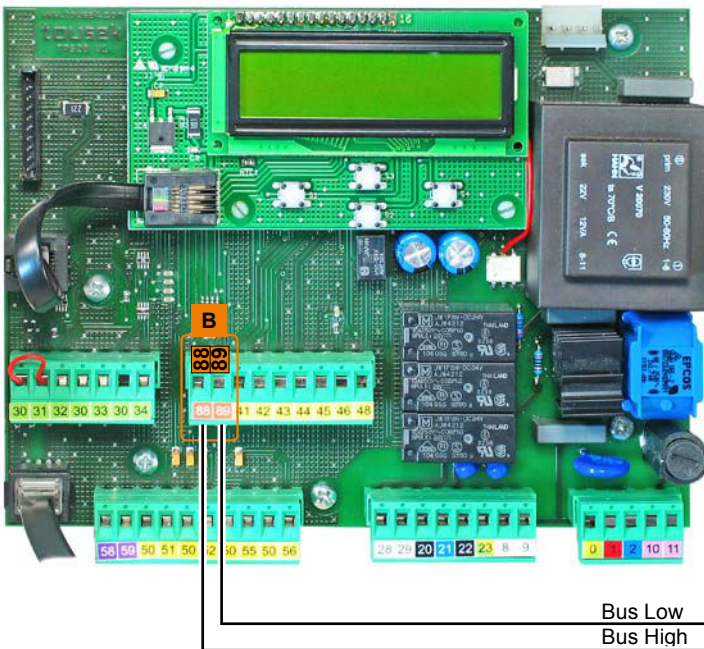

Traffic light control board STA 11

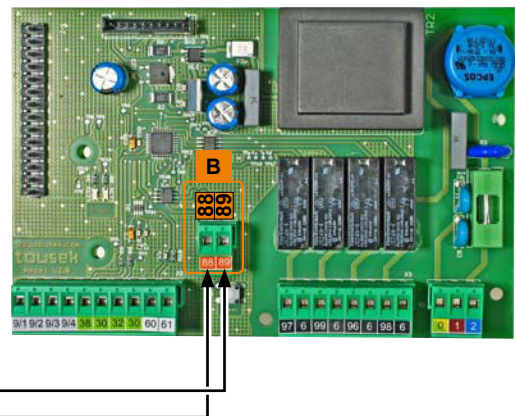

Bus Low
Bus High

General

- To implement traffic light function the control unit STA 11 has to be connected with the operator control unit TPS 20 via bus system.

Technical data

Traffic light control board STA 11 in plastic housing IP 54 (210 x 310 x 125mm)	
Power supply	230Va.c., +/-10%, 50Hz
Relay load Red/Green traffic light	230V, max. 60W
Article no.	12120370
Optional equipment	induction loop detector ISD 6 (2-channels) • pluggable receiver

Function

The traffic light control enables in conjunction with a suitable operator control board the automation and control of the gate entry and exit through a traffic light.
 At the terminals of the traffic light controller separate impulse generators can be connected for „inside“ and „outside“.
 The behavior of the traffic light control is determined by the settings of the connected operator control board. These relate to the function of the duration of the green phase and the clearance time, the traffic light at the door position „closed“ (whether or continuous red) and the traffic light system logic.
 Depending on how the „traffic light logic“ was adjusted, after completion of command processing and gate opening, either the side, which has given the order, or both sides receive the green light. Vehicles can therefore only drive in one direction or both directions entering the gate area. Furthermore, the traffic light controller has the capacity to store incoming transit needs and to work at the end of the current cycle.

Functional sequence		Traffic light (command giving side)	Traffic light (counter side)	
1	Gate / barrier closed Continuous red function adjustable via operator control board	selectable no continuous red	OFF	OFF
		continuous red	RED	RED
2	opening command (INSIDE or OUTSIDE)		RED	RED
	Prewarning OPEN is being started (= red traffic light warning and possibly signal light warning before opening the door / gate), duration adjustable via gate automation control board > Gate/barrier opens after the prewarning time.			
3	Gate/barrier open (limit position reached) traffic light logic, adjustable via operator control board	selectable both sides Green	GREEN	GREEN
		one side Green	GREEN	RED
4	Green phase is started ⓘ Duration is adjustable through operator control board			
5	Clearance time is started (= time to exit the traffic light intermediary region) Duration of adjustable drive control		RED	RED
	> Gate/barrier closes after clearance time, cycle starts again (→ 1) • if during the closing procedure an impulse is generated, so the gate / gate opens immediately, and the green phase begins when the opening is completed.			
ⓘ	<ul style="list-style-type: none"> • If a further order from one side is given with traffic light logic „both sides Green“ during the green phase/clearance time is given, then the <u>green phase is restarted</u>. • If a further order from the <u>same side</u> is given with traffic light logic „one side Green“ during the green phase/clearance time, then a <u>restart of the green phase</u> for this side is effected. • If a further order from <u>the counter side</u> is given with traffic light logic „one side Green“ during the green phase/clearance time, then the barrier/gate remains after the green phase/clearance time open and the <u>Green display changes to the counter side</u>. 			



When the stop button is triggered, the gate stops moving and only opens again with command by either side.

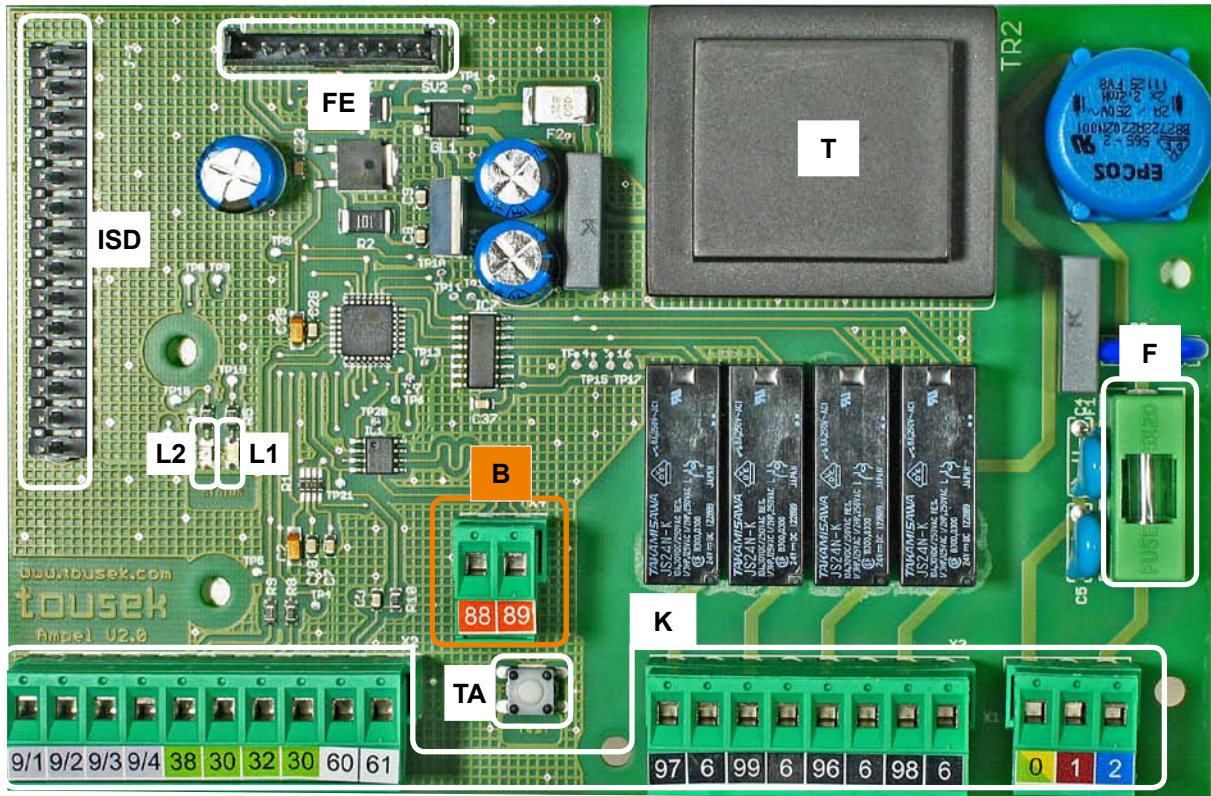

Components of traffic light control board

- (K) Terminals
- (B) Bus terminals (connection with operator control unit)
- (TA) Test button (switches all traffic lights on)
- (L 1) green LED: Status OK
- (L 2) red LED: error (message on the display of the drive control)
- (T) Transformer
- (ISD) Slot for optional induction loop detector (p. 39) (command)
- (FE) Slot for optional radio receiver (p. 38)
- (F) fuse 3,15A T



For connection, adjustment and maintenance works ensure that the electronics are not damaged by moisture (rain).



Warning

- Before opening the control board box, please switch off necessarily the main switch!
- In-supplied control inside the unit is powered.
- the safety regulations to prevent electrical shock have to be respected.
- The unit is designed to be connected by qualified personnel.
- The device must not be used in hazardous areas!
- A pole disconnecting main switch with a min. contact gap of 3mm has to be provided. The system must be protected in each case in accordance with applicable safety regulations!
- IMPORTANT: The control lines (buttons, radio remote control, light barriers, etc.) have to be separated from the 230 lines (supply, motor, signal light) to relocate



With TPS 20, -N, -PRO no limit switch is necessary: terminals 60/61 have to be wire bridged!

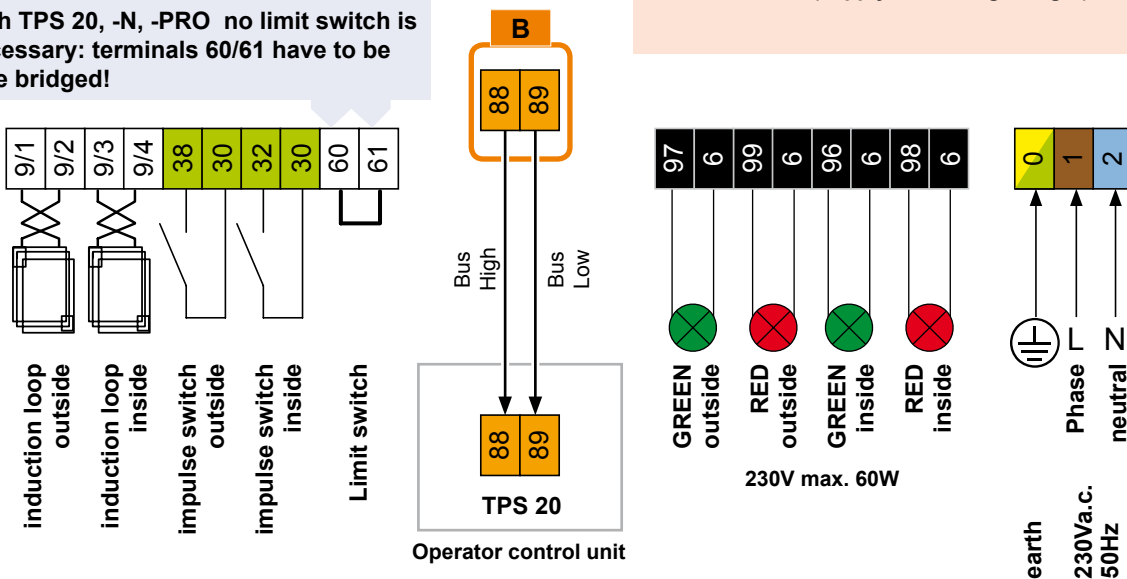



Induction loops

- For the use of induction loops (for Green/Opening command) the I-loop slot (ISD) of the traffic light board STA 11 has to be equipped with an optional available I-loop detector ISD 6 (2-channels). (see page 39)

Induction loop input (outside: term. 9/1+9/2, inside: term.9/3+9/4)

Connections

- For the connection of induction loops to give an impulse to the green request.
- With the 2-channel I-loop detector ISD 6 both loops (inside/outside) can be evaluated.

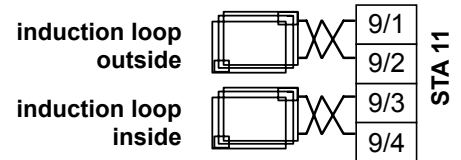

Impulse switch (outside: term. 38/30, inside: term. 32/30)

Connections

- For the connection of impulse switches on the inside and outside to give an impulse for the green request. **The impulse is also possible via an optional, plug-in radio receiver - see next page.**
- The green switching for one or both sides is dependent on the adjustment of the traffic light logic of the operator control board (see operator control board).

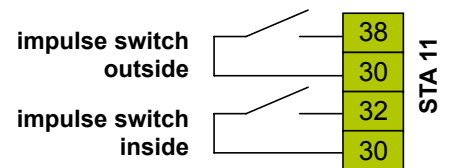

Limit switch input (term. 60/61)

Connections



Important

With the operator control TPS 20, -N, -PRO no limit switch connection at the traffic control unit STA 11 is necessary, **instead the terminals 60/61 must be wire bridged!**

STA 11



Traffic light outputs

outside: GREEN: term. 97/6, RED: term. 99/6

inside: GREEN: term. 96/6, RED: term. 98/6

Anschlüsse

- on the described terminals Red/Green traffic lights (230V max. 60W) can be connected for inside and outside location.

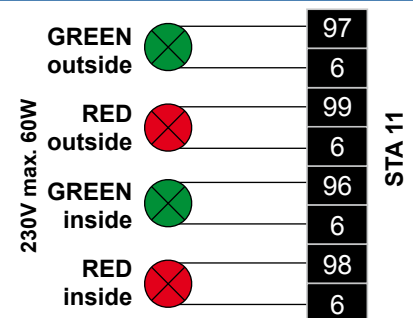

Connection traffic light board with operator control board (term. 88/89)

Connections

- Via the bus system (see pic.) the traffic light control board is connected with the operator control board.



Important

- Max. cable length between automation and traffic light control is 25m.
- Cable type e.g.: PVC control cable 2 x 1mm² YSLY or equivalent.

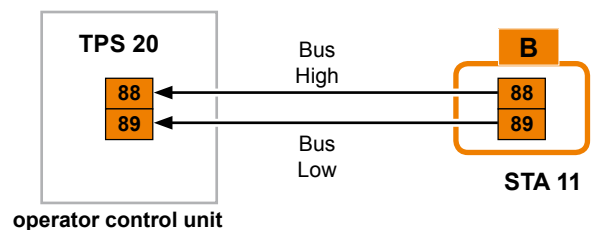

Adjustments

- The functions of the traffic light control is determined by the settings of the connected operator control board. These relate to the duration of the green phase and the clearance time, the traffic light at the closed door position (whether or continuous red) and the traffic light system (both sides / one side green).



Important

- The optional available radio receiver card has to be plugged **onto the slot (FE) of the traffic light control board STA 11.**
- The radio receiver slot of operator control unit TPS 20 is **without function** when used with traffic light control board STA 11.

- Turn off power supply.



- Plug-in the receiver printed circuit board (E) RS433/868-STN1 (1-channel) or RS433/868-STN2 (2-channels) into the corresponding slot (FE) as shown in the picture.
- To increase the range an external antenna FK433 or FK868 can be connected.



Important

- With the use of the 2-channel-receiver the first channel takes over the function for the impulse switch outside and the second channel the function for the impulse switch inside.
With the RS 433 version a connecting cable from the terminals of the receiver board to the inner impulse button input of the control unit is required.
- For programming of receiver please *see manual for radio receiver.*

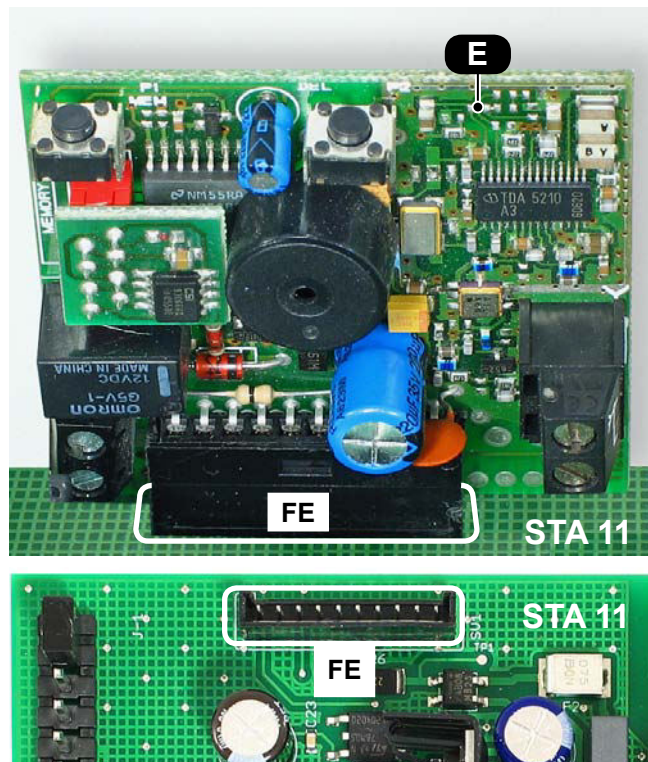



Important

- The device is for plugging onto a compact control board. The compact control board has to be built into a separate housing with IP54-insulation.
- After each device setting a readjustment is carried out automatically. After a change in the frequency (DIP switch 1: OFF / ON) the Reset-button (RES) has to be pressed.
- **Special notes for loop:** The safe function of the device depends essentially on the correct technical installation and of the laying of the loop wire, as these are the sensors of the device. The loop should not be mechanically loaded or moved. The loop feed line has to be twisted for **approx. 20 to 50 times per meter** and separated from any voltage carrying lines.
- With the 2 channel induction loop detector ISD 6 both loops can be evaluated (the green / open request inside and outside can be realised).
- The loop connection has to be made to **terminals 9/1-9/2 (= loop 1) and 9/3-9/4 (= loop 2)**.
- Detailed informations can be found in the corresponding manual.

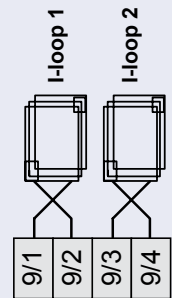

STA 11

Mounting and installation



Switch off the power supply. open the control board housing and plug the I-loop detector onto the connection slot as shown on picture.

- All detector settings can be made easily with the rotary switches (**D1**) for channel 1 and (**D2**) for channel 2 as well as the DIP-switches (**DIP**). see corresponding manual.

Factory settings (DIP1–DIP8 = OFF, D1 and D2 = 4).

LED's	for channel	display
G1 (green)	1	detection
G2 (green)	2	
R1 (red)	1	defective
R2 (red)	2	
PWR (yellow)	blinking when adjusting / power	

- DIP** DIP-switch
- RES** Reset-button
- M** Molex bar
- D1** rotary switch channel 1
- D2** rotary switch channel 2

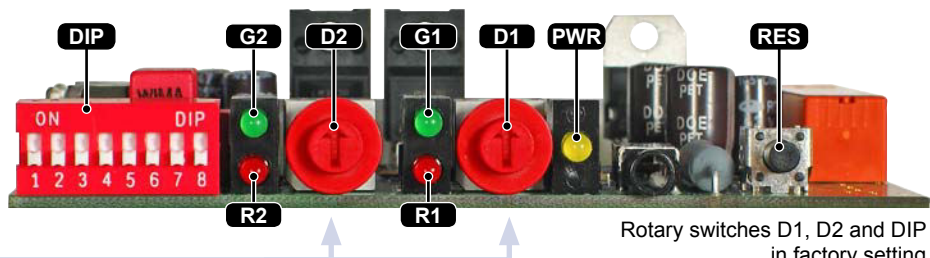
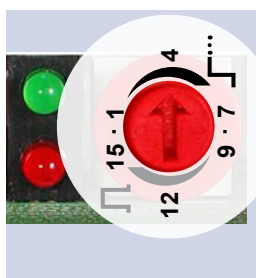
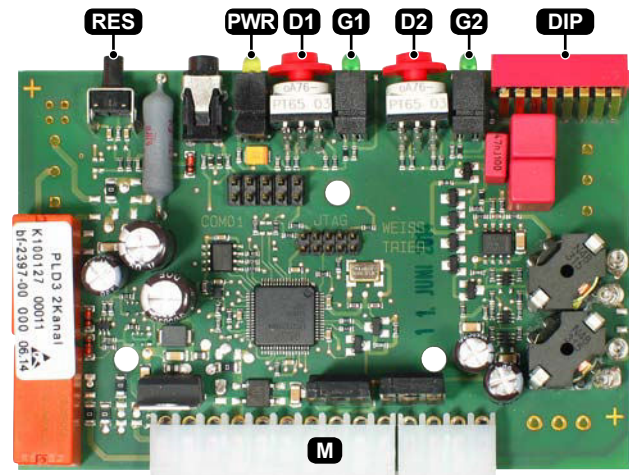

Rotary switches D1, D2 and DIP in factory setting

The Reset button (**RES**) has 2 functions which can be activated via the different duration of the key pressure:

- **Adjustment:** short key pressure (< 2s), Initialization of all activated loop channels.
- **Reset:** average duration of the key press (> 2s), reset the detector, subsequent initialization of all channels.



Insert the board of the induction loop detector on the slot (**ISD**) of the traffic light control unit **STA 11**.

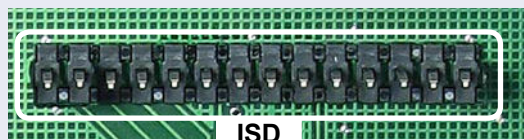

ISD

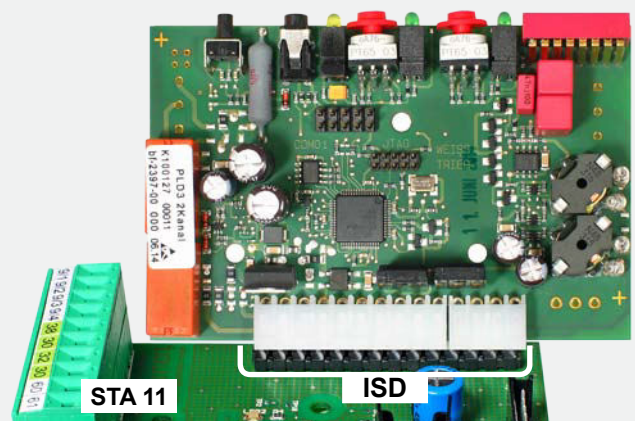

STA 11

ISD

Error	possible reason	solution
Display: „Stop-button released“	stop-button not connected or not bridged	Stop-button connect or bridge > use status display for help
Display: „Photocell released“	concerned photocell interrupted	check correct connection hence remove obstacle > use status display for help
Display: „PHC-back area released“		
Display: „MCE released“		
Display: „SE1 released“	concerned safety edge interrupted or hot-wired	check correct connection hence remove obstacle > use status display for help
Display: „SE2 released“		
Display: „SE3 released“		
Display: „AR-System released“	Gate ran into an obstacle or is too hard to move	check adjustment of forces, remove obstacle hence check if gate is easy to move
Display: „photocell test negative“	concerned photocell interrupted or hot-wired	check correct connection hence remove obstacle > use status display for help
Display: „PHC back area test negative“		
Display: „MCE test negative“ (only when using the TX 310)	Short-circuit or interruption of concerned safety edge	check correct connection hence battery status of transmitter > use status display for help
Display: „SE3 test negative“ (only when using the TX 310)		
No reaction when giving an impulse	no line voltage hence safety fuse broken	check line voltage as well as safety fuses
	error of transmitter/control device/impulse button, e.g. transmitter not programmed	check transmitter/control device, e.g. program transmitter and check battery
Control relays are switching but no gate movement	motor is in emergency release (unlocked)	lock motor gearing

10. Cable plan

- 1 operator TOUSEK TPS 20
- 2 a - outer photocell / b - inner photocell
- 3 antenna for built-in radio receiver
- 4 key-operated contact switch
- 5 signal flashing light
- 6 fuse 12A

- 7 main switch 16 A

Note: An all-pole disconnecting main switch with a contact opening-gap of minimum 3 mm has to be foreseen.

- 8 s - safety sensing edge (safety during closing)
- o - safety sensing edge (safety during opening)
- 9 power supply system TX100 for moving gate components. When using other power supply system (e.g. TX200i)
- 10 connection socket
- 11 stop momentary contact switch

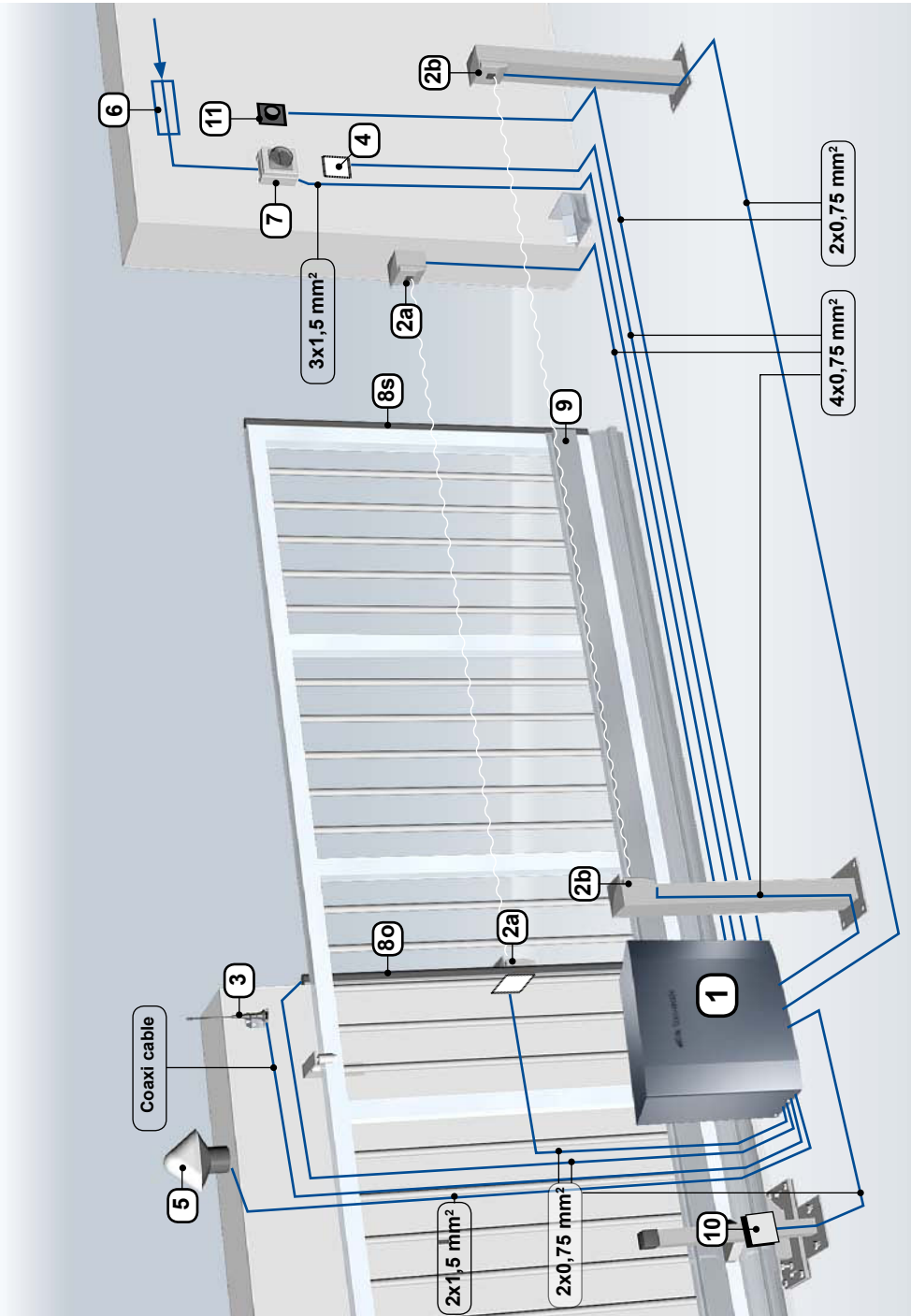

NOTE concerning cable laying

The electric cables have to be laid in insulating sleeves which are suitable for underground usage. The insulating sleeves have to be lead into the inner of the operator housing.

230 V cables and control lines have to be laid in separate sleeves.

Only double-insulated cables, which are suitable for underground usage (e.g. E-YY-J) may be used.

In case that special regulations require another type of cable, cables according to these regulations have to be used.



SAFETY NOTE

Please be aware that the beside picture is only a symbolic sample illustration of a gate facility and may therefore not show all safety devices required for your specific application.

To achieve an optimum safety level at your gate facility, please make sure that all safety components and accessories which - according to the applying safety rules and laws - are required in your particular case (e.g. photocells, induction loops, sensing edges, signal lamps, traffic lights, mains- and emergency power off switches etc.) are properly installed, operated, and serviced.

In this context please follow the EU Machine Directive, accident prevention rules and laws, as well as applying EU- and national standards in force at the time of installation and operation of the gate facility.

The Tousek Ges.m.b.H. cannot be held responsible for any consequences resulting from disregard of applying standards and laws during installation or operation of the gate facility.

The 0,75mm² control lines are shown without ground lead. In order to facilitate connections we recommend using flexible wires and not using thicker wires for the control lines.

11.1 Dimensional Drawing TPS 20

- Dimensions in mm

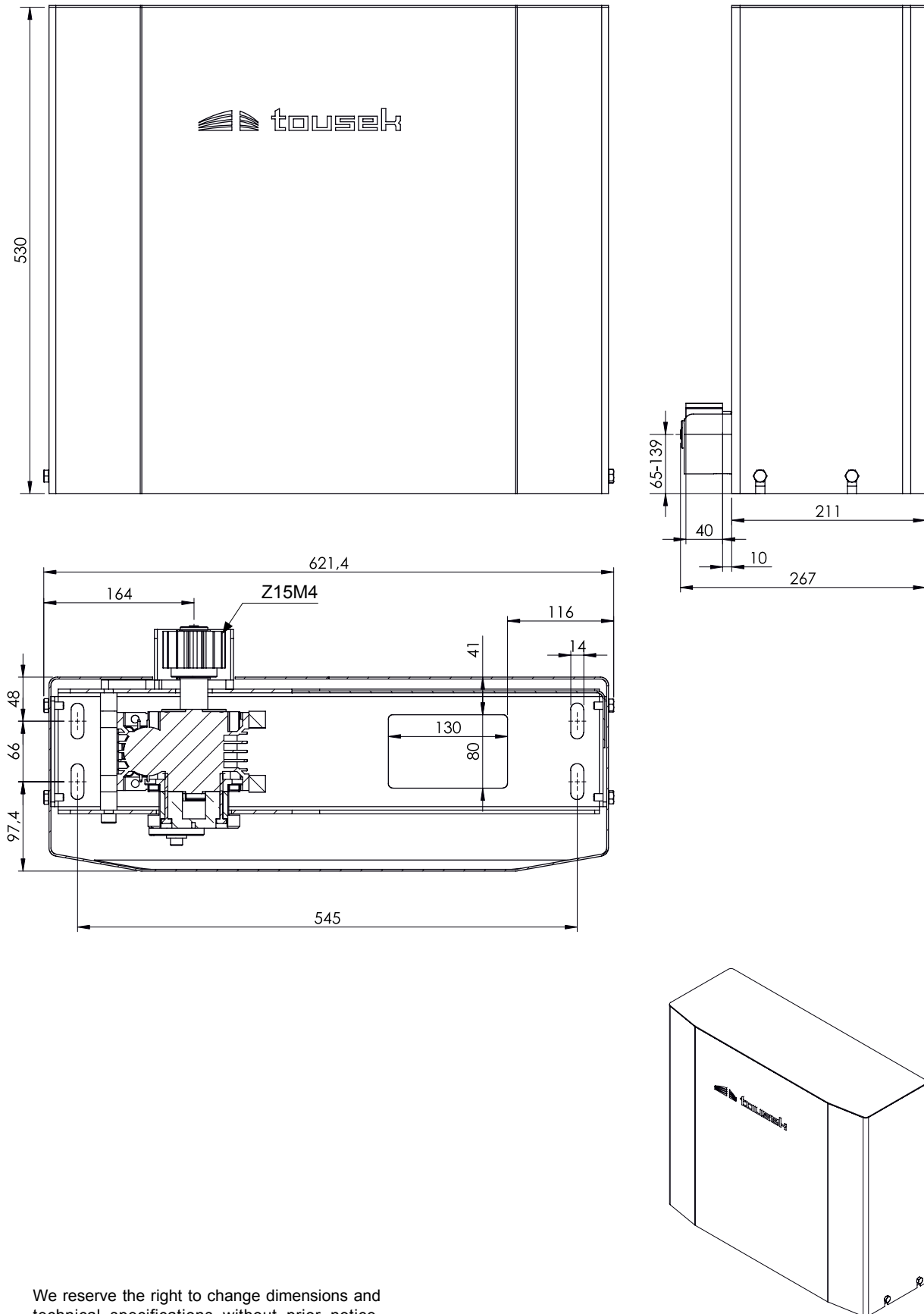

We reserve the right to change dimensions and technical specifications without prior notice.

11.2 Dimensional Drawing TPS 20N

- Dimensions in mm

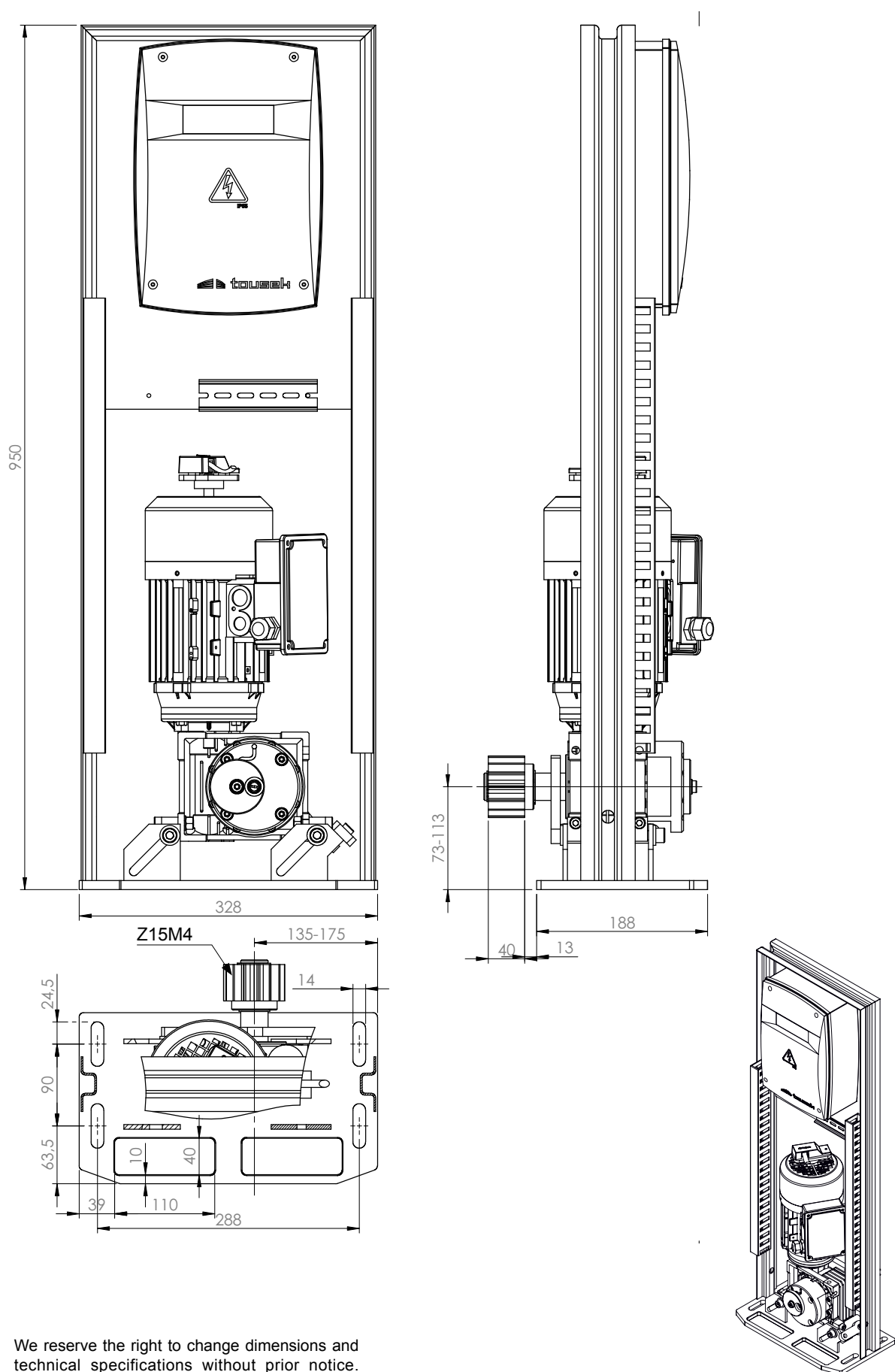

11.3 Dimensional Drawing TPS 20 PRO

- Dimensions in mm

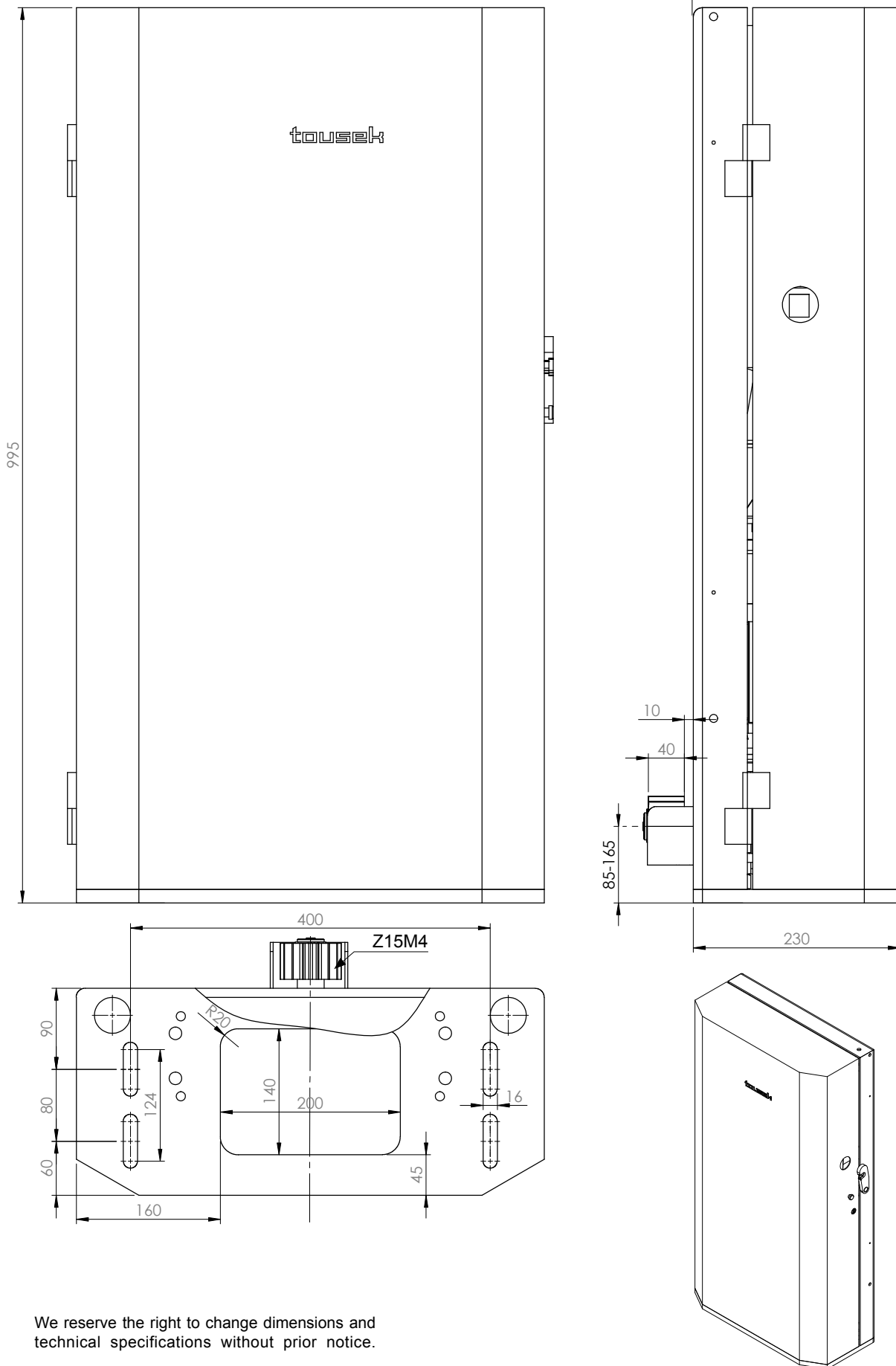

We reserve the right to change dimensions and technical specifications without prior notice.

Declaration of incorporation

In compliance with EC Machine Directive 2006/42/EC, Annex II B for the installation of an incomplete machine.

We hereby declare that the following product, as well as its version, put by us into circulation, complies with the essential requirements of the Machinery Directive (2006/42/EC), due to its design and type of construction.

The validity of this declaration will cease in case of any unauthorized modifications to the products.

The product:

Sliding gate opener

TPS 20, 20N, 20 PRO, TPS 20 Master/Slave, TPS 60 PRO

is developed, designed and manufactured in accordance with:

EG-Richtlinie Maschinen 2006/42/EG
EG-Richtlinie Niederspannung 2006/95/EG
EG-Richtlinie Elektromagnetische Verträglichkeit 2004/108/EG

Applied and used standards and specifications:

EN ISO 13849-1, PL-„c“
EN 60335-1
EN 60335-2/95
EN 61000-6-3
EN 61000-6-2

Following requirements of Annex I of the EC Directive 2006/42/EC are met:

1.1.2, 1.1.3, 1.1.5, 1.2.1, 1.2.2, 1.2.3, 1.2.6, 1.3.2, 1.3.4, 1.3.7, 1.5.1, 1.5.4, 1.5.6, 1.5.8, 1.7

The relevant technical documentation is compiled in accordance with Annex VII, Part B of the EC Machinery Directive 2006/42/EC.

We undertake to submit it in electronic form and within a reasonable time to the market surveillance authorities in response to a duly substantiated request.

TOUSEK Ges.m.b.H., A1230 Wien, Zetschegasse 1, Österreich

is authorized to compile the technical documentation.

The incomplete machine cannot be put into service, until it is determined that the machine, into which the incomplete machine has to be inserted, complies with the the Machine Directive 2006/42/EC.



Eduard Tousek, CEO

Vienna, 01. 01. 2013



EC Declaration of Conformity

In compliance with EC Machine Directive 2006/42/EC, Annex II, Part 1 A.

When the described operators are connected to a gate they form a machine in the sense of the EC Machine Directive.

Relevant EU directives:

Construction Products Directive 89/106/EWG
Machinery Directive 2006/42/EG
Electromagnetic compatibility 2004/108/EG
Low Voltage directive 2006/95/EG

We hereby declare that the following product, in the version put by us into circulation, complies with the essential requirements of the Directives mentioned above. The validity of this declaration will cease in case of any unauthorized modifications to the products.

Product:

Gate description

Motor description

The incomplete machine cannot be put into service, until it is determined that the machine, into which the incomplete machine has to be inserted, complies with the the Machine Directive 2006/42/EC.

Installation company

Address, ZIP code, Place

Date/ Signature

Motor number (Type plate): _____

Other components:

tousek PRODUCTS

- sliding gate operators
- cantilever systems
- swing gate operators
- garage door operators
- folding door operators
- traffic barriers
- carpark management system
- window operators
- domelight operators
- sliding door operators
- electronic controls
- radio remote controls
- key operated switches
- access control
- safety devices
- accessories

Tousek Ges.m.b.H. Austria
A-1230 Vienna
Zetschegasse 1
Tel. +43/ 1/ 667 36 01
Fax +43/ 1/ 667 89 23
info@tousek.at

Tousek GmbH Germany
D-83395 Freilassing
Traunsteiner Straße 12
Tel. +49/ 8654/ 77 66-0
Fax +49/ 8654/ 57 196
info@tousek.de

Tousek GmbH Switzerland
CH-6275 Ballwil
Bahnhofstraße 14
Tel. +41/ 0/ 41 448 2965
Fax +41/ 0/ 41 448 2966
info@tousek.ch

Tousek Benelux NV
BE-3930 Hamont - Achel
Buitenheide 2A/ 1
Tel. +32/ 11/ 91 61 60
Fax +32/ 11/ 96 87 05
info@tousek.nl

Tousek Sp. z o.o. Poland
PL 43-190 Mikołów (k/Katowic)
Gliwicka 67
Tel. +48/ 32/ 738 53 65
Fax +48/ 32/ 738 53 66
info@tousek.pl

Tousek s.r.o. Czech Republic
CZ-130 00 Praha 3
Jagellonská 9
Tel. +420/ 2/ 2209 0980
Fax +420/ 2/ 2209 0989
info@tousek.cz

tousek
E_TPS-20_03
30. 08. 2016



your service partner:

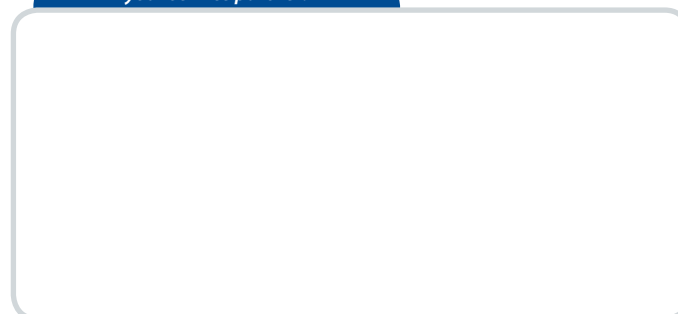

We reserve the right to change dimensions and/or technical specifications without prior notice. Claims resulting from misprints or errors cannot be accepted.

