

# Connection and installation manual

## Swing gate control unit ST 51

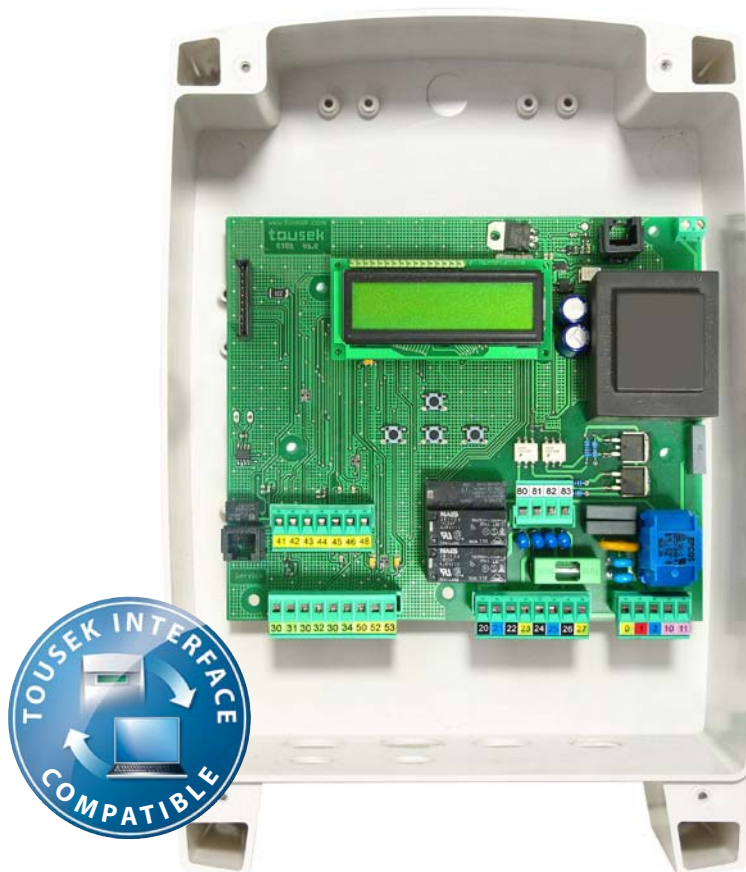

**tousek**<sup>®</sup>  
G A T E   A U T O M A T I O N



# Content

<b>General warning and safety notes</b> .....	<b>3</b>
<b>1. General features, control board overview, technical data</b> .....	<b>4</b>
<b>2. Terminal assignment, connection notes</b> .....	<b>5</b>
<b>3. Adjustments - overview</b> .....	<b>6</b>
programming keys, program menu, basic settings .....	6
menu structure .....	7
<b>4. Connections and adjustments</b> .....	<b>8</b>
<b>Buttons/switches</b> .....	<b>8</b>
[G] Impulse button (terminals 30/32) .....	8
Pedestrian button (terminals 30/34) .....	9
STOP-button (terminals 30/31) .....	9
<b>Safety</b> .....	<b>10</b>
Inner and outside photocell .....	10
[G] Inner photocell (contact: terminals 45/46) .....	10
[G] Outer photocell (contact: terminals 45/48)t .....	10
Photocells - connection examples .....	11
Safety contact edges .....	12
[G] Main safety edge 1 (terminals 50/52) .....	12
[G] Main safety edge 2 (terminals 50/53) .....	12
Photocell function inside .....	14
Photocell function outside .....	14
Photocell pause time .....	14
Photocell self test .....	14
Motor connection .....	15
<b>Left leaf</b> .....	<b>16</b>
Left motor (terminals 20/21/22, earth: 23) .....	16
[G] Delay left leaf .....	16
[G] Delay time left .....	16
Run-time OPEN .....	16
Run-time CLOSE .....	16
max. force OPEN .....	16
max. force CLOSE .....	16
Soft stop time .....	16
<b>Right leaf</b> .....	<b>16</b>
Right motor (terminals 24/25/26, earth: 27) .....	16
[G] Delay right leaf .....	16
[G] Delay time right .....	16
Run-time OPEN .....	16
Run-time CLOSE .....	16
max. force OPEN .....	16
max. force CLOSE .....	16
Soft stop time .....	16
<b>Operating mode</b> .....	<b>17</b>
Impulse button .....	17
[G] Operating mode .....	17
Partial opening .....	17
Runtime (LZ)-correction .....	17
Automatic mode .....	17
Pause time logic .....	17
Higher contact pressure .....	17
Safety edges (MSE 1: terminals 50/52, MSE 2: terminals 50/53) .....	18
<b>Light / Lamps</b> .....	<b>18</b>
Prewarning OPEN (terminals 10/11) .....	18
Prewarning CLOSE (terminals 10/11) .....	18
<b>Peripherals</b> .....	<b>19</b>
Electric lock (terminals 72/73) .....	19
Reverse stroke (only with activated electric lock !) .....	19
<b>Diagnosis</b> .....	<b>20</b>
Status display, factory setting, software version, serial number, protocol .....	20
<b>5. Connection of radio receiver</b> .....	<b>21</b>
<b>6. Initial operation</b> .....	<b>22</b>
<b>7. Error analysis</b> .....	<b>26</b>
<b>8. Dimensioned drawing housing IP54</b> .....	<b>27</b>



## General warning and safety notes

- These installation and operating instructions form an integral part of the product “**control unit**”. They have been specifically written for professional installers trained and skilled in the trade and should be carefully read in their full length before carrying out the installation. It concerns the control only, not of the overall device “automatic gate”. After the installation this manual has to be handed over to the user.
- **Installation, connection, adjustments, putting into operation, and servicing may only be carried out by trained professionals in full accordance with these installation and operating instructions.**
- **Before carrying out works on the gate system, the power supply has to be turned off.**
- Before taking off the housing cover, always turn off the mains switch!
- The EU Machine Directive, laws and rules concerning the prevention of accidents, and laws and standards which are in force in the EU and in the individual countries have to be strictly followed.
- The TOUSEK Ges.m.b.H. can not be held liable for any claims resulting from disregards of the laws and standards in force during the installation and operation.
- The packaging materials (cardboard, plastic, EPS foam parts and filling material etc.) have to be properly disposed of in accordance with the applying recycling and environmental protection laws. They may be hazardous to children and therefore have to be stored out of children’s reach.
- The product is not suitable for installation in explosion-hazardous areas.
- The product may only be used in accordance with its original purpose, for which it has been exclusively designed, and which is described in these installation and operating instructions. The TOUSEK Ges.m.b.H. rejects any liability if the product is used in any way not fully conforming to its original purpose as stated herein.
- **Children have to be instructed** that the gate facility as well as the belonging parts may not be used improperly, e.g. for playing. Furthermore handheld transmitters have to be kept in safe places and other impulse emitters as buttons and switches have to be installed out of children’s reach..
- Before beginning with the installation the installer has to make sure that all mechanical components of the gate facility, like carrier profile/rail, gate frame and panels, guiding elements etc. are sufficiently supportive and resistant for the purpose of gate automation.
- All electrical installations have to be made in full conformity with the applying rules and laws (e.g. using a fault current circuit breaker, proper grounding etc.).
- **An all-pole disconnecting main switch with a contact opening-gap of minimum 3 mm has to be foreseen.**
- **After installation the proper function of the gate facility and the safety devices has to be checked!**
- The TOUSEK Ges.m.b.H. rejects any liability for claims resulting from usage of the product in combination with components or devices which do not fully conform to the applying safety laws and rules.
- Only original spare and replacement parts may be used for repair of the product.
- The installer has to inform the user about all aspects of the automatic operation of the complete gate facility, as well as about emergency operation. The installer further has to supply to the user all instructions relating to the safe operation of the gate facility. The installation and operating instructions also have to be handed over to the user.



## Maintenance

- **Maintenance works may only be carried out by qualified personnel.**
- **Maintenance and servicing of the complete gate facility has to be carried out according to the gate builder’s/ installer’s instructions.**
- **Check the proper sensitivity setting of the ARS safety reverse system once a month.**

### EU - Manufacturer’s Declaration:

The company TOUSEK Ges.m.b.H., based in Zetschegasse 1, A-1230 Vienna/Austria, hereby declares that the control unit ST 51 complies with the following directives:

- Low Voltage Directive 2006/95/EC, incl. changes
- Electromagnetic Compatibility Directive 2004/108/EC, incl. changes

January 2012

## Control board features

- suitable for swing gates with electromechanical operators 230V (1 or 2 gate leaves)
- leaf delay adjustable at opening and closing
- automatic closure with adjustable pause time.
- Additional function for permanent open
- separately adjustable operating time of both operators
- separately adjustable softstop time of both operators.
- Separate force adjustment for opening and closing movement
- Operating mode: impulse-, automatic- or deadman mode
- Integrated evaluation of safety sensing edges
- self-monitoring of photocells
- self-diagnosis
- optionally available e-lock module
- slot for optional radio receiver
- easy programming thanks to text display

## Control board overview

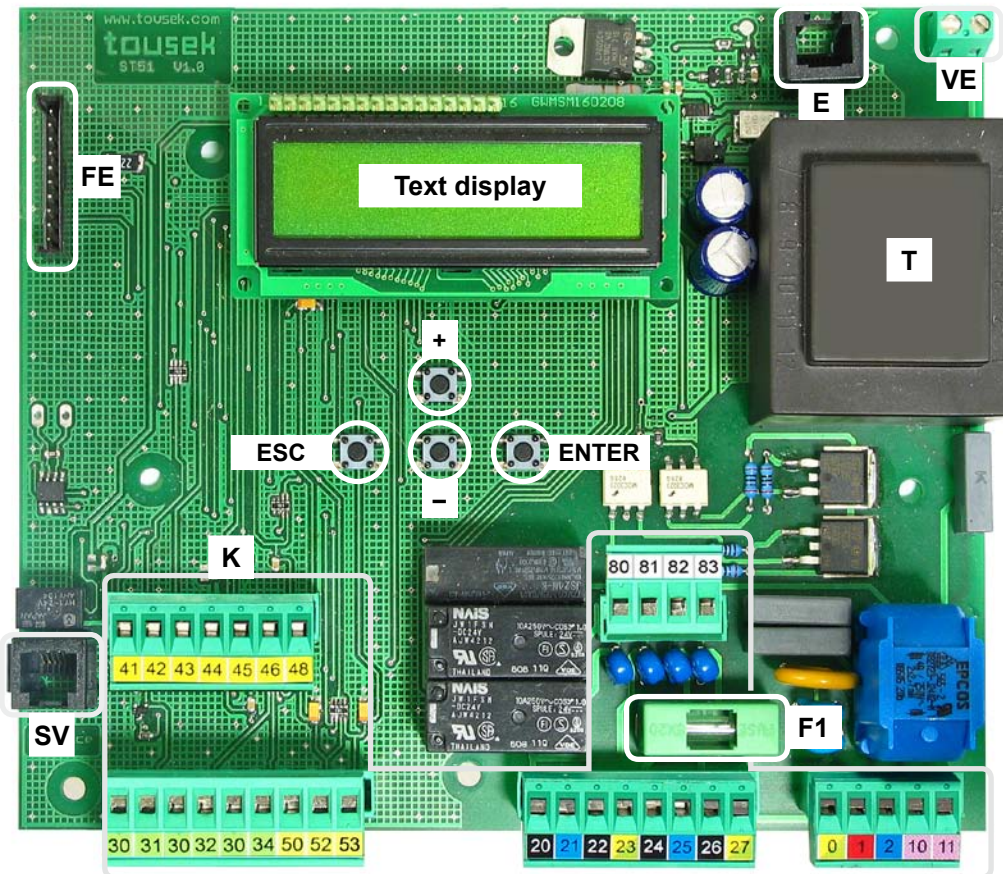

### Attention

After connecting the wires, secure it with cable ties (to tie). This is to prevent that a 230V line comes with a low-voltage power line in contact if a wire loosens from the terminal



### Important

The optional tousek-service-interface must be connected with socket (SV)!  
Not with (E) !



## Components of the control board

- (K) terminal blocks
  - (E) System connector for optional electric lock / magnet module (p.19)
  - (VE) 230V a.c. for electric lock/magnet module
  - (SV) service connector (e.g. for software update) or connection with optional tousek-service-interface (TSI)
  - (FE) slot for optional radio receiver (p.21)
  - (T) transformer
  - (F1) fuse 6,3A F
- Text display and programming keys +, -, ESC and ENTER

## Technical data

Swing gate control unit ST 51			
power supply	230V a.c., +/-10% 50Hz	magnet output (optional)	24Vd.c.
motor output	2 x 500W, 230V a.c.	ambient temperature	- 20°C + 70°C
flashing light output	230V AC, 40W	protection class	IP54
electric lock output	12Vd.c. oder 24V d.c.	Art.no.	12111660
photocell output	24V a.c.		
optional components	pluggable radio receiver • E-lock/magnet module • radio transmission system TX 310		



### Warning

- Before taking off the control cover, the mains switch must be turned off !
- The inside of the control unit is under tension when power supplied.
- In order to avoid electrical strokes, the safety regulations have to be respected.
- The device may only be connected by qualified personnel (specialised staff).



- The product is not suitable for installation in explosion-hazardous/explosive areas.
- An all-pole disconnecting mains switch with a contact opening gap of min. 3 mm has to be foreseen. The gate facility has to be secured according to the valid safety regulations!
- **IMPORTANT:** The control lines (buttons, radio, photocells, etc.) have to be laid separately from the 230V lines (supply line, motors, signal lamp).



### Important (TURN 310UF)

The operator TURN 310UF differs from the wiring diagram:

Left operator: black > term. 20 / brown > term. 22

Right operator: black > term. 26 / brown > term. 24

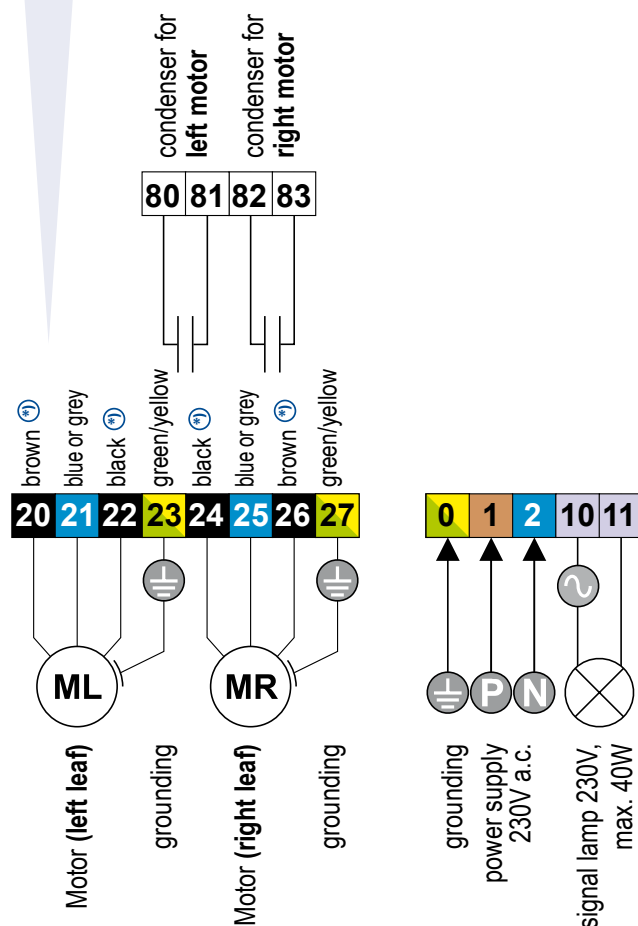
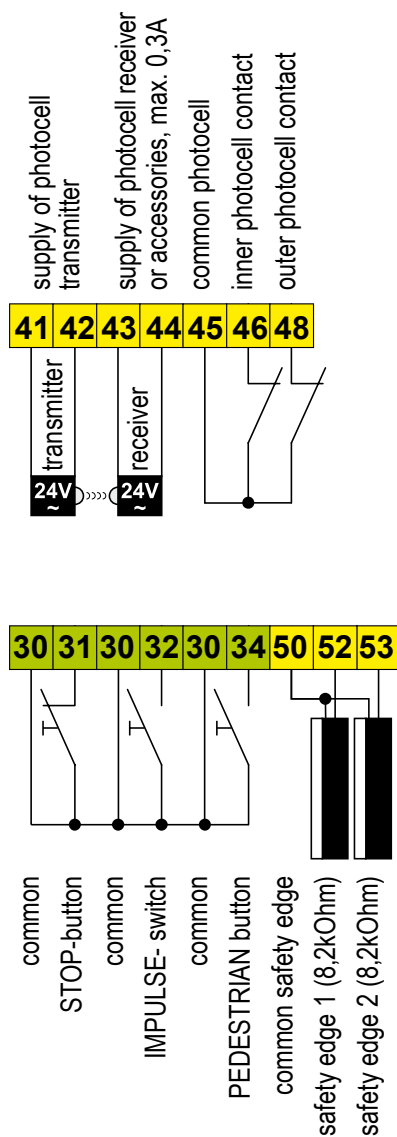

During connection, adjustment and maintenance works please take care that the electronic printed circuit board is not damaged by moisture (rain).

## Programming buttons

## Adjustments - Overview



- The adjustment (programming) of the operating parameters is carried out via four programming buttons and the text display.
- Before you can start programming, select the language of the display. You can do this by pressing the **+ or -** and choose the language for the menus and press **ENTER**.
- Note: The language setting can be changed any time by pressing the **ESC button for 5s**.

- The text display informs you on the operating modes, selected menus and adjustment of several parameters.
- The programming of the control is done through four buttons (**+, -, ENTER and ESC**).
- Scrolling through the different menu points (up/down) and changing a parameter (increase/decrease) is done with **buttons + and -**. **AUTO-COUNT:** When a button is pressed and held, an automatic scrolling of the menu (or change of the parameter) is carried out.
- By pressing the **ENTER-button** you enter the displayed menu point or memorise the shown value of a parameter.
- By pressing the **ESC-button** you return to the superior menu point. Changed adjustments of a parameter are rejected with this button (the original value is kept).
- **AUTO-EXIT:** If during programming no button is actuated for 1 minute or longer, the programming mode is left automatically. The control is set „ready“ **without storage** of possibly changed values.

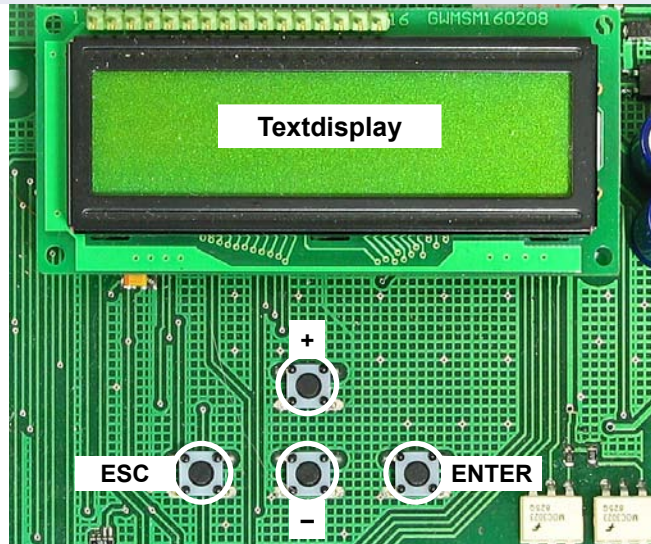

## Programming menu

## Adjustments - Overview



- The programming menu is divided into „BASIC SETTINGS“ and the „MENU CONTROL“

**BASIC SETTINGS**

- When programming the control the **first time**, you enter the „**BASIC SETTINGS**“.
- Here the necessary adjustments for operation of the gate facility are made.
- Entering the menu control (for extended programming) is possible by selecting „**MENU CONTROL**“.

**MAIN MENU CONTROL**

- The next time you will directly enter „**MENU CONTROL**“. (The BASIC SETTINGS are skipped.)
- The menu control contains all possible adjustments.



In the following the single menu points are marked as shown below:

- = possible adjustment (or value assignment)    ⊙ = factory setting    ⇄ = status display  
 [G] marks the menu points which are contained in the BASIC SETTINGS.

Note: some adjustments regarding function or operating logic can only be executed if gate is closed and if the display shows „ready“.

Main layer	Sub layer	Adjustments
<b>buttons/switches</b> <i>see page 8</i>	impulse button	<input type="radio"/> OPEN/STOP/CLOSE <input type="radio"/> OPEN/CLOSE/OPEN <input type="radio"/> OPEN <input type="radio"/> DEAD MAN
	pedestrian button	<input type="radio"/> OPEN/STOP/CLOSE <input type="radio"/> OPEN/CLOSE/OPEN <input type="radio"/> OPEN <input type="radio"/> DEAD MAN *)
<b>safety</b> <i>see page 10</i>	inner photocell	<input type="radio"/> active <input type="radio"/> not active
	outer photocell	<input type="radio"/> active <input type="radio"/> not active
	main safety edge 1	<input type="radio"/> active <input type="radio"/> not active <input type="radio"/> radio edge TX310
	main safety edge 2	<input type="radio"/> active <input type="radio"/> not active <input type="radio"/> radio edge TX310
	photocell function inside	<input type="radio"/> during closing reverse <input type="radio"/> stop - after release open <input type="radio"/> during opening stop - then open
	photocell function outside	<input type="radio"/> during closing reverse <input type="radio"/> stop - after release open
	PHC-pause time	<input type="radio"/> no influence of photocell <input type="radio"/> abort pause time <input type="radio"/> re-start pause time <input type="radio"/> immediate close after opening
	PHC-self test	<input type="radio"/> active <input type="radio"/> not active
<b>left leaf</b> <i>see page 16</i>	left motor	<input type="radio"/> motor ON <input type="radio"/> motor OFF
	delay left leaf	<input type="radio"/> opening delay <input type="radio"/> closing delay
	delay time left	<input type="radio"/> 0...25s <span style="float: right;">⊖ = 2s</span>
	runtime OPEN	<input type="radio"/> 3...90s <span style="float: right;">⊖ = 20s</span>
	runtime CLOSE	<input type="radio"/> 3...90s <span style="float: right;">⊖ = 20s</span>
	max. force OPEN	<input type="radio"/> 30...100% <span style="float: right;">⊖ = 70%</span>
	max. force CLOSE	<input type="radio"/> 30...100% <span style="float: right;">⊖ = 70%</span>
	soft stop time	<input type="radio"/> 0...25s <span style="float: right;">⊖ = 5s</span>
<b>right leaf</b> <i>see page 16</i>	right motor	<input type="radio"/> motor ON <input type="radio"/> motor OFF
	delay right leaf	<input type="radio"/> opening delay <input type="radio"/> closing delay
	delay time right	<input type="radio"/> 0...25s <span style="float: right;">⊖ = 2s</span>
	runtime OPEN	<input type="radio"/> 3...90s <span style="float: right;">⊖ = 20s</span>
	runtime CLOSE	<input type="radio"/> 3...90s <span style="float: right;">⊖ = 20s</span>
	max. force OPEN	<input type="radio"/> 30...100% <span style="float: right;">⊖ = 70%</span>
	max. force CLOSE	<input type="radio"/> 30...100% <span style="float: right;">⊖ = 70%</span>
	soft stop time	<input type="radio"/> 0...25s <span style="float: right;">⊖ = 5s</span>
<b>operating mode</b> <i>see page 17</i>	impulse button	<input type="radio"/> stop, start of pause time <input type="radio"/> impulse suppression when opening <input type="radio"/> pause time extension
	operating mode	<input type="radio"/> impulse mode <input type="radio"/> automatic 5...255s
	partial opening	<input type="radio"/> 25...100% <span style="float: right;">⊖ = 100%</span>
	runtime correction	<input type="radio"/> open +10...turned off...closing +10 <span style="float: right;">⊖ = OFF</span>
	automatic mode	<input type="radio"/> complete/partial opening <input type="radio"/> only complete opening <input type="radio"/> only partial opening
	pause time logic	<input type="radio"/> no influence <input type="radio"/> permanent open in automatic mode
	increase pressure	<input type="radio"/> OFF <input type="radio"/> 0,1...3s
	closing edges	<input type="radio"/> left/right <input type="radio"/> inside/outside
<b>lights/lamps</b> <i>see page 18</i>	prewarning OPEN	<input type="radio"/> OFF, 1...30s <span style="float: right;">⊖ = OFF</span>
	prewarning CLOSE	<input type="radio"/> OFF, 1...30s <span style="float: right;">⊖ = OFF</span>
<b>peripherals</b> <i>see page 19</i>	electric lock	<input type="radio"/> switched off <input type="radio"/> 1...10s
	reverse stroke reverse stroke only with active e-lock!	<input type="radio"/> switched off <input type="radio"/> 0,5...8s
<b>diagnosis</b> <i>see page 20</i>	status display	<input checked="" type="radio"/> status display
	factory setting	<input type="radio"/> NO <input type="radio"/> YES
	Software version	<input checked="" type="radio"/> shows software version
	serial number	<input checked="" type="radio"/> shows serial number
	protocol	<input checked="" type="radio"/> shows protocol events



## Warning



- Before taking off the control cover, the main switch must be turned off!
- If the control is power supplied, its inner part is under tension.
- In order to avoid electrical strokes, the safety regulations have to be kept.
- The device may only be connected by trained professionals.
- The product is not suitable for installation in explosion-hazardous areas.
- An all-pole disconnecting main switch with a contact opening gap of min. 3 mm has to be foreseen. The gate facility has to be secured according to the valid safety regulations!
- **IMPORTANT:** The control lines (buttons, radio, photocells, etc.) have to be laid separately from the 230V lines (supply line, motors, signal lamp).



The single menu points are marked as shown below:

○ = possible adjustment (or value assignment)    ⊙ = factory setting    ⇄ = status display

Ⓜ marks the menu points which are contained in the BASIC SETTINGS.

- A general status display of all inputs is available in menu DIAGNOSIS/STATUS DISPLAY.

## Buttons/switches

## Connections and adjustments

### Ⓜ Impulse button (terminals 30/32)

## Buttons/switches

#### ⊙ OPEN/STOP/CLOSE successive impulses (factory setting):

An impulse of the impulse switch makes the motor start opening/closing. If the impulse switch is actuated again during this opening-/closing movement, the motor stops. With the next command of the impulse switch the motor moves in the opposite direction of the last gate movement.

- OPEN/CLOSE/OPEN successive impulses: an impulse of the impulse switch makes the motor start opening/closing. If the impulse switch is actuated again during this opening/closing movement, the travel direction is reversed.

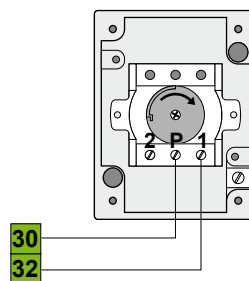

Impulse switch  
(e.g. key switch EPZ 1-2T)



- In this operation mode it is not possible to stop the motor with the impulse switch – it always moves until reaching an end position. (Opened or closed position).
- for the function OPEN/CLOSE/OPEN we strongly suggest the installation of a photocell!

- OPEN: Only opening commands are accepted by the impulse switch – closing the gate with the impulse switch is not possible.
- DEAD MAN: The motor opens as long as the impulse switch is pressed (hold) – closing the gate with the impulse switch is not possible. As soon as the switch is released, the motor stops. If dead man's operation (=hold to run) is chosen, the radio receiver is out of order for reasons of safety.



- If the impulse switch is set to DEAD MAN operation, then the pedestrian button works the same way. With the impulse switch the gate is opened, with the pedestrian button it is closed.
- **IMPORTANT: Do not put into operation in dead man mode. Select only after putting into operation (see page 22), if desired.**



Push buttons, key switches or external radio receivers with potential-free make contacts can be used as impulse switches



- **OPEN/STOP/CLOSE successive impulses:**  
An impulse of the pedestrian button makes the according gate leaf open/close. If the pedestrian button is actuated again during this movement, the motor stops. With the next impulse the motor moves in opposite direction of the last gate movement.
- **OPEN/CLOSE/OPEN successive impulses:**  
A command of the pedestrian button makes the according gate wing open/close. If the button is actuated again during this movement, the travel direction is reversed.

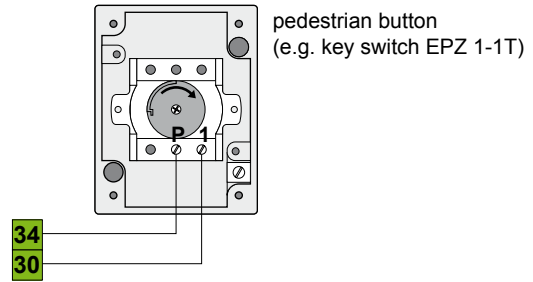

**!** • In this operation mode it is not possible to stop the motor with the pedestrian button – it always moves until reaching an end position. (Opened or closed position).  
• for the function OPEN/CLOSE/OPEN we strongly suggest the installation of a photocell!

- **OPEN:** Only opening commands are accepted by the impulse switch – closing the gate with the impulse switch is not possible.
- **DEADMAN:** The motor opens as long as the impulse switch is pressed (hold) – closing the gate with the impulse switch is not possible. As soon as the switch is released, the motor stops. **As soon as the deadman function is activated, the radio receiver is without function (due to safety reasons).**

**➔** The DEADMAN function can not be chosen actively but is set automatically as soon as the impulse button is set to DEADMAN mode.

**➔** Push buttons, key switches or external radio receivers with potential-free make contacts can be used as pedestrian button..

- When pressing the stop switch the gate stops in any desired position.

**➔ Important**

**31** ← **30** If no STOP switch is connected, terminals 30/31 have to be wire-bridged.

A break contact has to be used as stop switch. If the switch is actuated, the gate stops in any desired position.



INNER AND OUTER PHOTOCELL

Safety

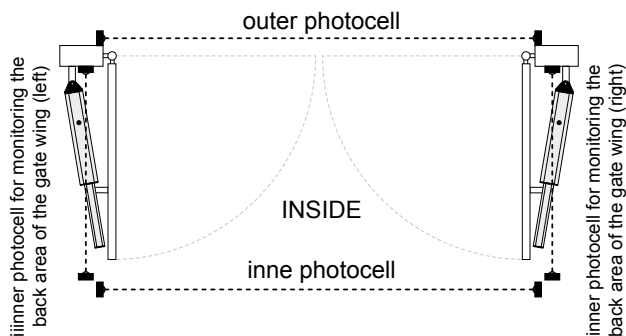

- **energy saving mode (only if no radio transmission system TX 310 is used):** photocell transmitter is turned off when gate is closed.
- With **additional inner photocells** the back area of the gate can be monitored. (All inner photocells are then set in series at control terminals 45/46 (terminals for inner photocells)).
- The exact function of the photocells depends on the programming of the control unit: **Photocell functions see page 14.**



Important: notes for photocells

- The control unit has a power supply connection for a 24V a.c. photocell (LS):  
supply LS-transmitter: terminals 41/42 / supply LS-receiver: terminals 43/44  
**Note:** in „gate closed“ position the terminals 41/42 are being switched into energy saving mode (no current) (only if the radio transmission system TX 310 is not used) !
- At supplied and positioned photocells the contact has to be closed (make contact).  
Connection of outer photocell contact: terminals 45/48, inner photocell contact terminals 45/46

- When using two pairs of photocells please do not install both photocell transmitters/receivers on the same side (to eliminate interference between both) !

**Exception: photocells with SYNC function allow the installation of both photocell transmitters/receivers on the same side without causing interference to each other.**

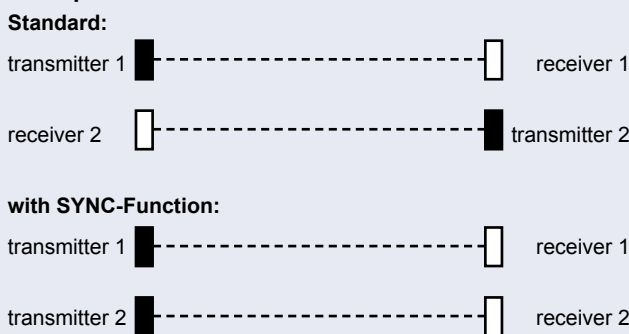

- **Self-monitoring of photocells:** The control is equipped with a self-monitoring function for the connected photocells. With each starting impulse (button/radio) the transmitter photocell is turned off for a short moment. Thus the receiver photocell interrupts contact 45/46 (inner photocell) or contact 45/48 (outer photocell) and the control is able to check the proper function of the photocell receiver. If this short interruption at the photocell input isn't carried out, the control displays an error.
- The exact function of the photocells depends on the programming of the control unit.  
**Photocell functions see menu point SAFETY/inner (outer) photocell function, resp. photocell with pause time (page 14).**
- **Detailed information you will find in the corresponding photocell manual.**

**G** Inner photocell (contact: terminals 45/46)

Safety

- ⊙ **active:** to be selected, if inner photocell should be triggered.
- **not active:** to be selected, if inner photocell should not be triggered.

**G** Outer Photocell (contact: terminals 45/48)

Safety

- ⊙ **active:** to be selected, if outer photocell should be triggered.
- **not active:** to be selected, if outer photocell should not be triggered.

## Photocells - connection examples

### Outer photocell Tousek LS 41 as safety device

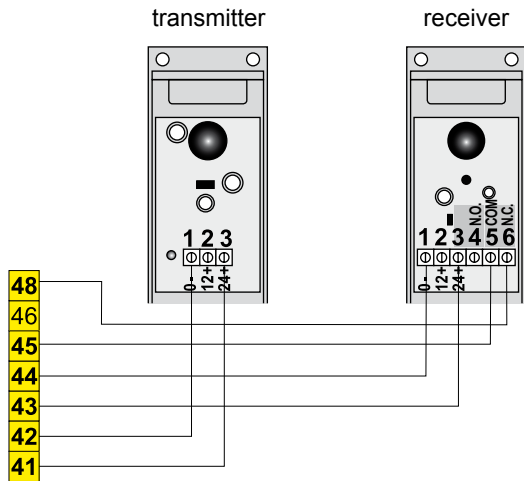

### Important

- To activate the SYNC-function, the plug-in bridges (J) in both photocell transmitters **have to be removed**. (see manual LS 41).

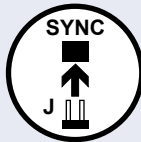

### Outer and inner photocell Tousek LS 41 as safety device

with active SYNC-function

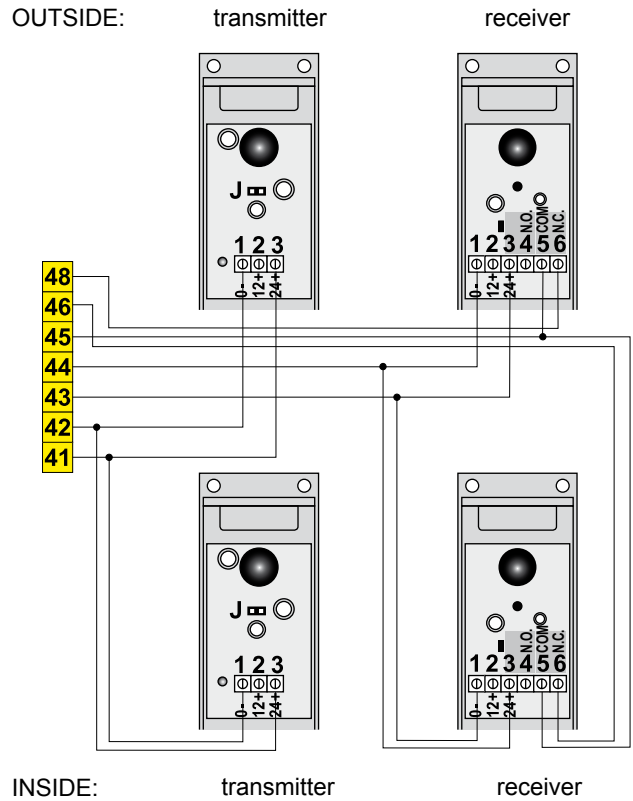

### Outer photocell Tousek LS 26 as safety device

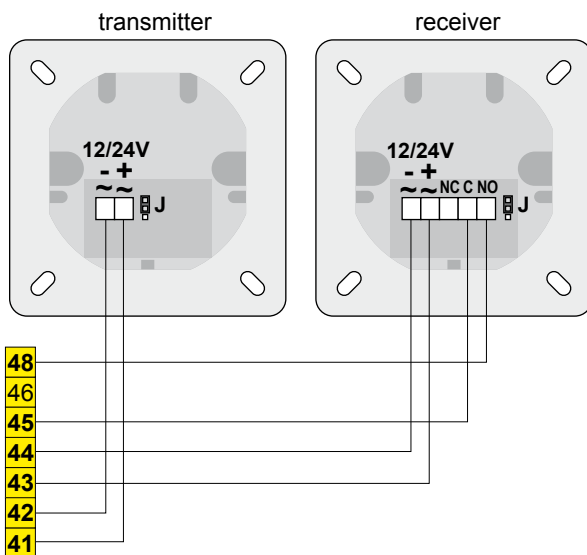

### Important

- Jumper J of transmitter and receiver has to be adjusted in the same way.

### Outer reflective photocell Tousek RLS 610 as safety device

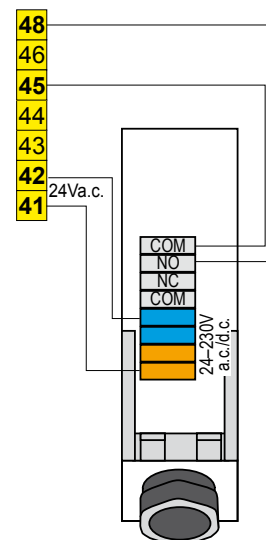



**Safety sensing edges (main closing edge 1 + 2)**

- **OBSTACLE DETECTION:** when a contact strip/safety edge is triggered/activated then a change of direction is effected for 1 second. After that the gate continues to move in the changed direction.
- The activation of the safety sensing edges is made in menu „**Safety / main closing edge 1**“ (term. 50/52) and „**Safety / main closing edge 2**“ (term. 50/53)
- If in the menu item „**operating logic / closing edge**“ (see page 18) one of the modes „**left / right**“ or „**inside / outside**“ is selected - this results in the wiring of the safety contact edges to make with each other and the connection to the control terminals.

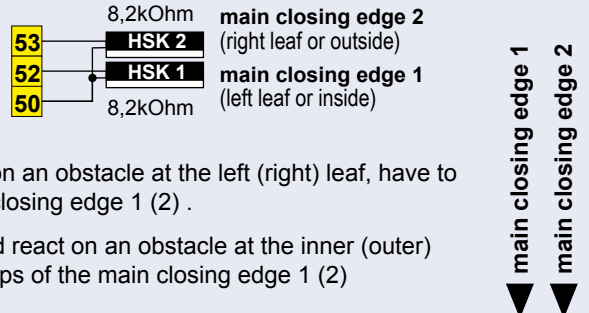

Safety sensing edges in mode „**left/right**“, that should react on an obstacle at the left (right) leaf, have to be connected (serially) to the connection clamps of the main closing edge 1 (2) .

Safety sensing edges in mode „**inside/outside**“, which should react on an obstacle at the inner (outer) side of the leaf, be connected (serially) to the connection clamps of the main closing edge 1 (2)

**Example:** W 8,2kΩ final resistance  
 E final edge  
 D passage edge  
 S to the control board

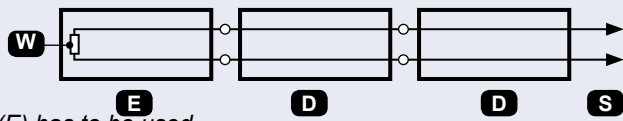

When connecting one safety edge a final edge (E) has to be used.

**G Main safety edge 1 (terminals 50/52)**

- ⊙ **active:** to be selected if the contact strip (8,2kOhm) of main safety sensing edge 1 should be evaluated.
- **not active:** to be selected if the contact strip of main safety sensing edge 1 should not be evaluated
- **radio edge TX310:** to be selected if safety sensing edge (8,2kΩ) of main entrance edge 1 should be evaluated **with the radio transmission system TX 310.**

**G Main safety edge 2 (terminals 50/53)**

- ⊙ **active:** to be selected if the contact strip (8,2kOhm) of main safety sensing edge 2 should be evaluated.
- **not active:** to be selected if the contact strip of main safety sensing edge 2 should not be evaluated
- **radio edge TX310:** to be selected if safety sensing edge (8,2kΩ) of main entrance edge 2 should be evaluated **with the radio transmission system TX 310.**



• Connection and detailed information of radio transmission system TX 310 see according manual.



**Important (for programming)**

- **IMPORTANT:** during programming of motor the contact safety edges should not be triggered as this leads to an error message - the limit stops have to be placed correspondingly.



**Photocell function inside**

Safety

- ⊙ **during closing reverse:** an interruption of the photocell during closing makes the gate reverse (open). In automatic mode the gate closes as soon as the pause time has run out. In impulse operation another closing command has to be given.
- **stop - after release open:** an interruption of the photocell beam during opening or closing makes the motor stop as long as the photocell stays interrupted. After release of the photocell, the gate opens. In automatic mode the gate closes as soon as the pause time has run out, in impulse operation another closing command has to be given.
- **during opening stop - then open:** an interruption of the photocell during opening makes the motor stop as long as the photocell stays interrupted. After release of the photocell, the gate opens. (back area monitoring). In automatic mode the gate closes as soon as the pause time has run out, in impulse operation another closing command has to be given.

**Photocell function outside**

Safety

- ⊙ **during closing reverse:** an interruption of the photocell during closing makes the gate reverse (open). In automatic mode the gate closes as soon as the pause time has run out. In impulse operation another closing command has to be given.
- **stop - after release open:** an interruption of the photocell beam during opening or closing makes the motor stop as long as the photocell stays interrupted. After release of the photocell, the gate opens. In automatic mode the gate closes as soon as the pause time has run out, in impulse operation another closing command has to be given.

**PHC-pause time**

Safety

- ⊙ **no influence of photocell:** the photocell doesn't have any influence on the pause time in automatic mode.
- **abort pause time:** in automatic mode an interruption of the outer photocell during pause time shortens the pause time. After release of the photocell the gate starts closing.
- **re-start pause time:** in automatic mode an interruption of the outer photocell during pause time, restarts the pause time. As soon as the pause time has run out, the gate closes.
- **immediate close after opening:** If the outer or inner photocell is interrupted during the opening movement or if the outer photocell is interrupted in open position, then the gate begins to close after the release of the photocell.

**PHC-self test**

Safety

- ⊙ **active:** photocell self-test is executed with an opening impulse (switch, button) in gate position „closed“.
- **not active:** photocell self-test is not executed

**Attention**

- The photocell self-test can only be deactivated by selecting „not active“.
- The deactivation of the self-test function is only permitted if the safety installations correspond to the category 3 !



**Important: notes for connection and adjustment of operators**

- It is possible to connect 2 motors 230V (max. 500W/motor) with control board ST51.
- **Attention:** Before carrying out any installation and connection works, the power supply of the gate facility has to be turned off.
- Please pay attention that after turning on the power supply and giving an impulse the gate wings have to open. In case that they don't open, for the left operator terminals 20/22 and for the right one terminals 24/26 have to be crossed out.
- **Important:** At operation with a single motor, the other motor input has to be deactivated by choosing „MOTOR OFF“. If the LEFT (RIGHT) wing is set to OFF in the menu, no motor may be connected with the concerned wing.

**Important: OPERATION ADVICE FOR ELECTROHYDRAULIC GATE OPERATORS**

When connecting electrohydraulic operators to the ST50 please notice that the softstop function has to be deactivated and that the force control of the ST50 should be adjusted to the maximum. The force control adjustment is made directly on the operators (see the corresponding instruction manual of the operator)

**Mandatory settings of the control unit for electrohydraulic operators:**  
 Softstop time= 0 max force OPEN = 100% max. force CLOSED = 100%



**Warning**

- Before taking off the housing cover the main switch has to be turned off !
- **IMPORTANT:** At force adjustment (see Left(Right) wing) the valid safety regulations and standards have to be strictly followed!
- Follow safety instructions (see page 8) !



**Important (TURN 310UF)**

The operator TURN 310UF differs from the wiring diagram:

**Left operator:** black > term. 20 / brown > term. 22  
**Right operator:** black > term. 26 / brown > term. 24

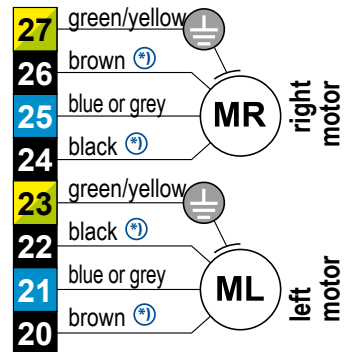
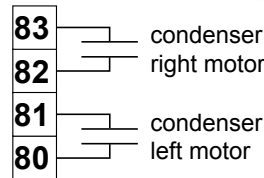

**Connection of condensers for operators**

- **ATTENTION:** the control unit should be switched-off before the connecting works of the condensers begin !
- 2 condensers have to be connected to the ST50 as follows:  
 for **left operator** use the **clamps 80/81**  
 for **right operator** use the **clamps 82/83**  
 (please see connecting diagram above)
- To fix the 2 condensers inside the operator housing please use the sockets. After having mounted the condensers with the lace to the sockets they should be fixed on the inside of the operator control housing.
- The placement of the condensers can be chosen freely, but we recommend the lower area of the operator control housing, as shown on picture.

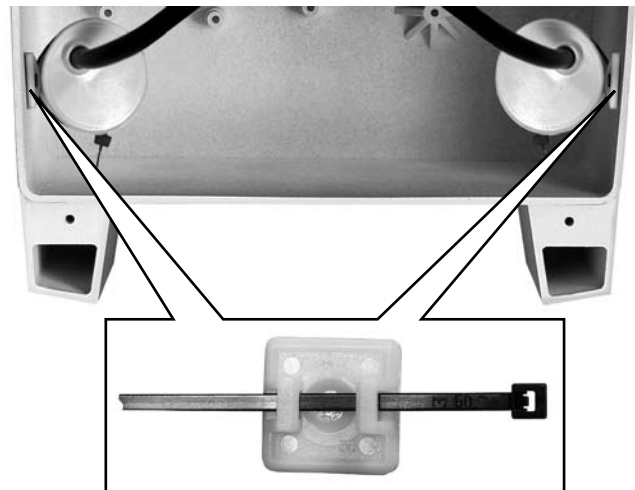

**Left motor** (terminals 20/21/22, grounding: 23)

Left leaf

- motor ON
- motor OFF

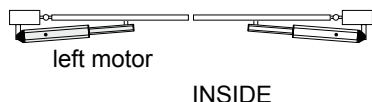

**Important**

- If a left operator is not available then set here to „MOTOR OFF“!

Left leaf

**Delay left leaf**

- opening delay:** the left leaf opens after the adjusted delay time.
- closing delay:** the left leaf closes after the adjusted delay time.

**Delay time left**  2s (factory setting)

Left leaf

- 0–25s delay time adjustable:** indicates the delay time at opening or closing.

**Runtime OPEN**  20s (factory setting)

Left leaf

- 0–90s adjustable:** defines the run-time in opening movement incl. soft stop time.

**Runtime CLOSE**  20s (factory setting)

Left leaf

- 0–90s adjustable:** defines the run-time in closing movement incl. soft stop time.

**Max. force OPEN**  70% (factory setting)

Left leaf

- 30–100% adjustable:** indicates the motor force during the opening movement.

**Max. force CLOSE**  70% (factory setting)

- 30–100% adjustable:** indicates the motor force during the closing movement.

**Soft stop time**  5s (factory setting)

- 0–25s adjustable:** indicates the set softstop time.



**Important !**

- **Mandatory settings of the control unit for electrohydraulic operators** (also see page15):  
 max. force OPEN = 100%  
 max. force CLOSE = 100%  
 soft-stop time = 0

**Right motor** (terminals 24/25/26, grounding: 27)

Right leaf

- motor ON
- motor OFF

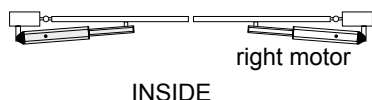

**Important**

- If a right operator is not available then set here to „MOTOR OFF“!

Right leaf

**Delay right leaf**

- opening delay:** the right wing opens after the adjusted delay time.
- closing delay:** the right wing closes after the adjusted delay time.

**Delay time right**  2s (factory setting)

Right leaf

- 0–25s delay time adjustable:** indicates the delay time at opening or closing.

**Runtime OPEN**  20s (factory setting)

Right leaf

- 0–60s adjustable:** defines the run-time in opening movement incl. soft stop time.

**Runtime CLOSE**  20s (factory setting)

Right leaf

- 0–90s adjustable:** defines the run-time in closing movement incl. soft stop time.

**Max. force OPEN**  70% (factory setting)

Right leaf

- 30–100% adjustable:** indicates the motor force during the opening movement

**Max. force CLOSE**  70% (factory setting)

- 30–100% adjustable:** indicates the motor force during the closing movement.

**Soft stop time**  5s (factory setting)

- 0–25s adjustable:** indicates the set softstop time.



**Important !**

- **Mandatory settings of the control unit for electrohydraulic operators** (also see page15):  
 max. force OPEN = 100%  
 max. force CLOSE = 100%  
 soft-stop time = 0



**Impulse button**

Operating logic

- ⊙ **stop, start of pause time:** a command of the impulse switch during movement stops the gate and starts the pause time in automatic operation – as soon as the pause time has run out, the gate closes automatically.
- **impulse suppression when opening:** commands which are emitted during the opening movement are suppressed. Commands during closing are accepted.
- **pause time extension:** an impulse in automatic operation restarts the pause time. If this menu point is chosen, the impulse suppression during opening is active at the same time.

**Operating mode**

Operating logic

- ⊙ **impulse mode:** for initiating the closing movement, an impulse is necessary.
- **automatic closing, pause time adjustable from 1-255s:** gate closes as soon as the adjusted pause time has run out.

**Partial opening** ⊙ 100% (factory setting)

Operating logic

- **25–100% adjustable:** indicates the partial opening of the gate leaf with closing delay in relation to complete opening width.

This adjustment is ONLY adopted in CLOSED Position.

**Runtime correction** ⊙ switched off (factory setting)

Operating logic

- **open +10...switched off...closing +10:** for adjustment of runtime correction in closing and opening movement. This correction is only effected in situations in which the gate stops during movement and moves into opposite direction. The runtime correction is an important adjustment with the use of electrohydraulic motors.

This adjustment is ONLY adopted in CLOSED Position.

**Automatic mode**

Operating logic

- ⊙ **complete/partial opening:** either with complete as well as partial opening, the gate closes automatically after the adjusted pause time.
- **only complete opening:** only after complete opening, the gate closes automatically after the adjusted pause time.
- **only partial opening:** only after partial opening the gate closes automatically after the the adjusted pause time.

**Pause time logic**

Operating logic

- ⊙ **no influence**
- **permanent open in automatic mode:** if this function is activated, the control unit goes from automatic mode into impulse mode **with activated pause time through impulse in open gate position for this cycle**, hence if gate is open then an impulse will end the automatic mode - the gate remains open. Only the next impulse will close the gate and the control unit goes back to automatic mode. With this function e.g. the entrance to a company site can remain open during the day (1st impulse in gate open position) and closed in the evening (2nd impulse). The control board switches back to automatic mode (autom. opening and closing of gate)..

**Increase pressure**

Operating logic

- ⊙ **OFF**
- **0,1–3,0s adjustable:** at the end of the closing movement the motor force is increased for this time in order to grant a proper locking of the gate.





## Closing edges (HSK 1: terminals 50/52, HSK 2: terminals 50/53)

Operating logic

- ⊙ **left/right:** the safety sensing edges (contact strips) can actuate in every gate movement (OPEN/CLOSE). Contact edges that should react on an obstacle on the **left leaf** (in serial connect.) should be connected on the terminals of the **main safety edge 1: term. 50/52**. Contact edges that should react on an obstacle on the **right leaf** (in serial connect.) should be connected on the terminals of the **main safety edge 2: term. 50/53**.

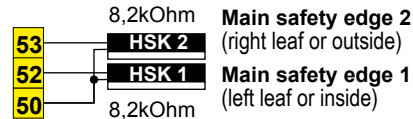

- **inside/outside:** Contact edges that should react on an obstacle at the **inside of** the leaf **during opening**, must be connected (serial) on the terminals of the **main safety edge 1: term. 50/52**. Contact edges that should react on an obstacle at the **outside of** the leaf **during closing**, must be connected (serial) on the terminals of the **main safety edge 2: term. 50/53**.

IMPORTANT !			ASSIGNMENT AND RESPONSE OF SAFETY EDGES	
Assignment		movement	opening	closing
HSK 1	Mode left/right	left	active	active
HSK 2		right	active	active
HSK 1	Mode inside/outside	inside	active	
HSK 2		outside		active

Examples:

left (HSK 1 - term.50/52)      right (HSK 2 - term.50/53)

(D) passage edge, (E) final edge

## Lights / Lamps

Connections and adjustments

### Prewarning OPEN (terminals 10/11)

Light / Lamps

- ⊙ **turned off**
- **1–30s adjustable:** before each opening movement the flashing light is activated for the adjusted time.

### Prewarning CLOSE (terminals 10/11)

Light / Lamps

- ⊙ **turned off**
- **1–30s adjustable:** before each closing movement the flashing light is activated for the adjusted time.



### Important: Notes regarding connection of a flashing light

- **Attention:** Before carrying out connection works, the power supply of the facility has to be turned off.
- A flashing light with 230V, max. 40W can be connected at the terminals 10/11.

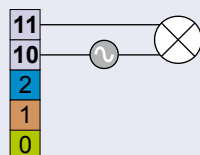

### Warning

- Before taking off the housing cover the main switch has to be turned off !
- Follow safety instructions (see page 8) !





## Optional module for electric lock/magnetic clamp

- The control unit ST 51 needs an optional module for connection of an electric lock/magnet (12V or 24Vd.c. version depending on electric lock).

### Connection of module

- ATTENTION: turn off power supply!** 
- Fix the module as illustrated in the control with screws at position **(P)**.
- Connect electric lock module via Western plug **(W1, W2)** with the control unit **(terminal E)**.
- Connect the electric lock (12/24Vd.c.) to the removable terminals **72/73** of the module.
- The magnet (24Vd.c.) must be connected via a resistor **(R)** for the connection to the module.
- To do this, push the connecting cable of the magnetic clamp as shown into the opening of the series resistor and fix by means of crimping pliers.
- Connect the connection cable and resistor **(R)**, as shown, to the removable terminals **74 (-) / 75 (+)** of the module. **Pay attention to polarity**.
- The supply is connected to the 2-pin connector cable **(V)** to the control terminals **(VE)**.
- After wiring, the E-lock-mode has still to be activated in the menu of the control under LIGHT PERIPHERAL / ELECTRIC LOCK.
- Magnets are driven into the open and closed position of the gate, the electric lock only in closed position.

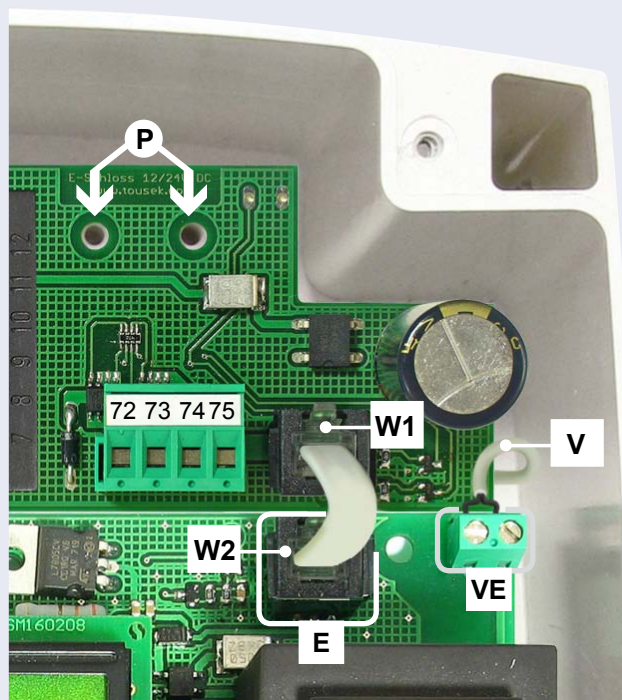

### Warning

- Before taking off the housing cover the main switch has to be turned off!
- Follow safety instructions (see page 8)!

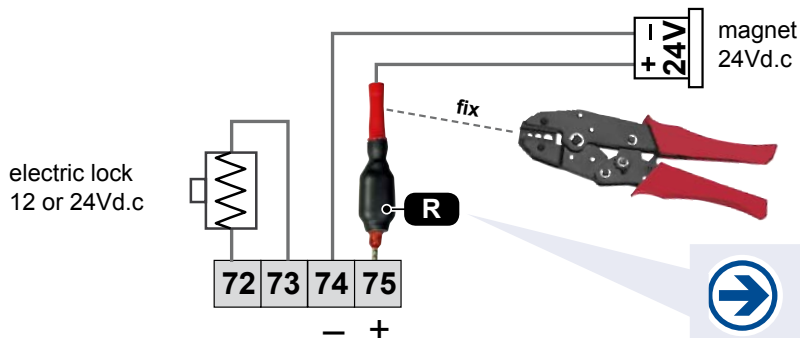

The series resistor (R) is for tousek magnets GD 50 and GD 70.

### Electric lock (terminals 72/73)

Peripherals

- switched off**
- 1–10s adjustable:** The electric lock is activated by push button impulse or impulse from pedestrian button for a period of time set here to ensure the release depending on the gate situation

### Reverse stroke (only with activated electric lock!)

Peripherals

- switched off**
- 0,5–8s adjustable:** If the function is activated, it starts after a pulse with the buttons or the remote control a quick closing movement, then switches the e-lock and the door opens (used for relaxation of e-lock before unlocking the case). If the e-lock function is not activated the reverse stroke is not executed.

Status display

Diagnosis

↪ status display for inputs as photocell, safety sensing edges, stop button, impulse switch...

- I impulse switch
- P partial opening switch
- C CLOSE-switch
- S STOP-switch
- Pi photocell inside
- Po photocell outside
- 1 safety edge main closing edge 1
- 2 safety edge main closing edge 2

- █ Status: OK
- ▬ Status: not OK or triggered
- ⊗ Status: safety contact edge interrupted
- Status: not active

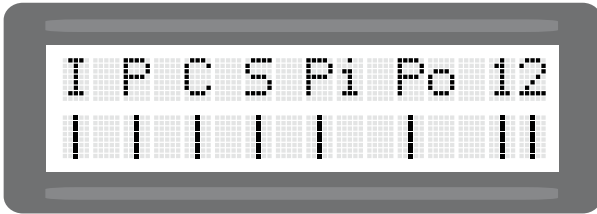

z.B.

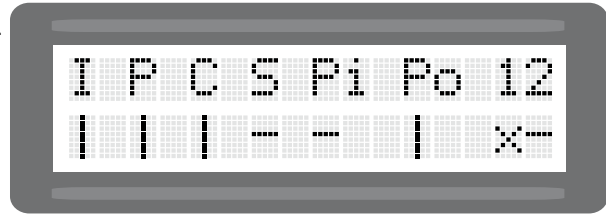

All inputs OK.

Stop-button and inner photocell not okay or triggered. Safety sensing edge (main closing edge 1) triggered. Safety sensing edge (main closing edge 2) short-circuited. All other inputs are okay.

Factory setting

Diagnosis

- ⊙ NO: no reset to factory setting
- YES: reset to factory setting



Note: The factory settings of the single menu points are marked with ⊙ in this manual.

Software version

Diagnosis

↪ shows the software version on the text display

Serial number

Diagnosis

↪ shows the serial number on the text display

Protocol

Diagnosis

↪ shows the protocole list on display: all events that take place are protocolled in this list. with the buttons + and - the single events can be seen:

With \* the protocole beginning hence the end is shown

Time since the last event:  
DAYS HOURS : MINUTES : SECONDS

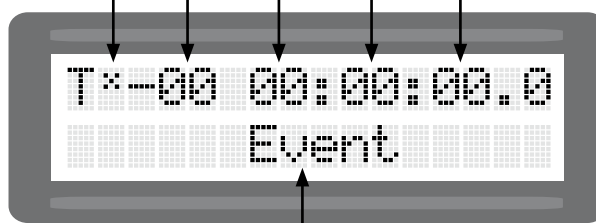

Type of event

## 5. Connecting the receiver

Swing gate control unit ST 51

- Disconnect the power supply



- Plug-in the receiver printed circuit board (E) RS433/868-STN1 (1 channel) or RS433/868-STN2 (2 channels) into the corresponding slot (FE) as shown in the picture.
- For range extension an external antenna FK433 or FK868 can be connected.



### Important

- With the use of the 2-channel-receiver the second channel takes over the function of the pedestrian entry mode switch.

With the RS 433 version a connecting cable from the terminals of the receiver board to the pedestrian button input of the control unit is required.

- For programming of receiver please *see manual for radio receiver.*

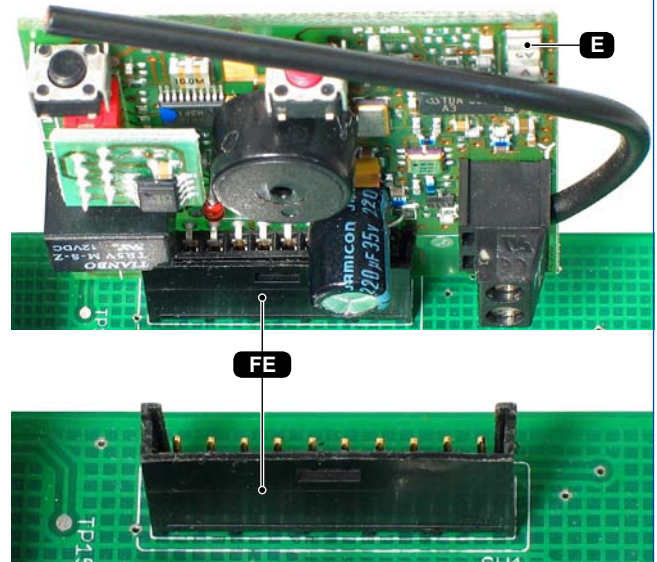
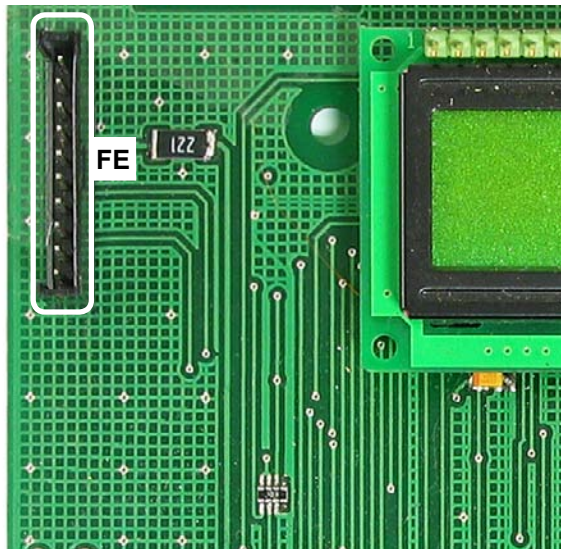



**Important: preparation works**

- Connect control panels, safety devices to the motor under the safety regulations in .
- **Attention: if no stop switch is connected then the terminals 30/31 have to be bridged.**
- **The mechanical limits have to be placed so that contact edges are not triggered, as this would lead to an error message**
- Unlock emergency release of operator and set gate to half-opened position. Then lock the operator again
- Then turn on the operator (correct connection necessary).
- **Important:** Putting into operation in Impulse mode (standard setting) and not in dead man mode.
- During initial operation the choice of language is made first, then in the “Basic settings” the adjustment of most important operator settings and after the system test, the automatic detection of limit positions of gate is made..

**LANGUAGE SELECTION**

- Can be selected during initial operation (hence after reset to factory settings).
- Can be also chosen by pressing the ESC button (↵) for 5s, from any position in menu.

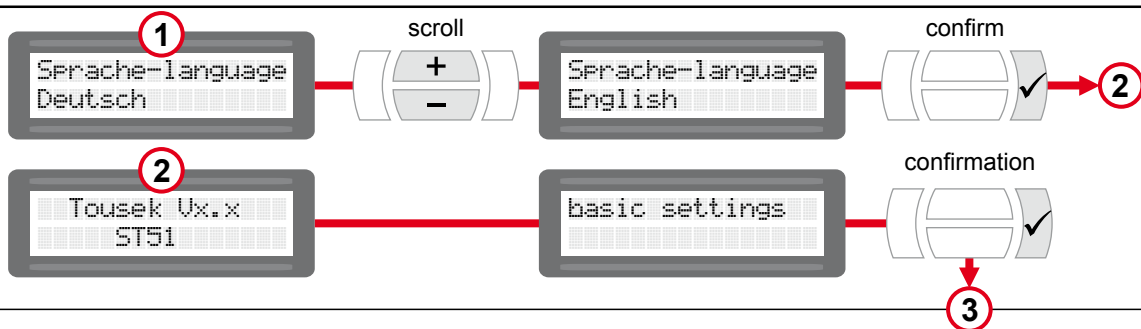

**BASIC SETTING**

- For setting the most important adjustments for initial operation of motor.
- Can be selected during initial operation (hence when restoring the factory setting).
- All safety devices are activated when leaving factory (siehe menu page 7).
- The next programming adjustments are made in the main settings menu (see page 6–7).

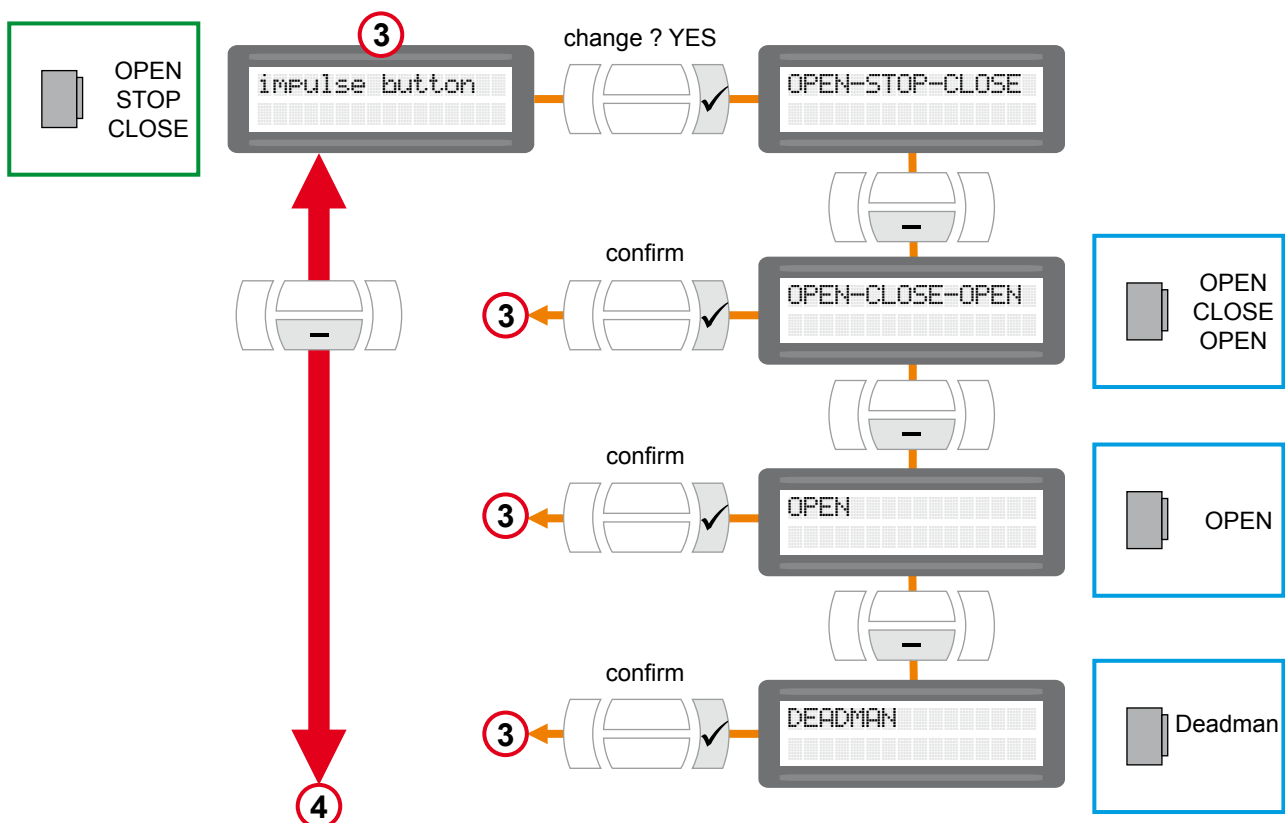

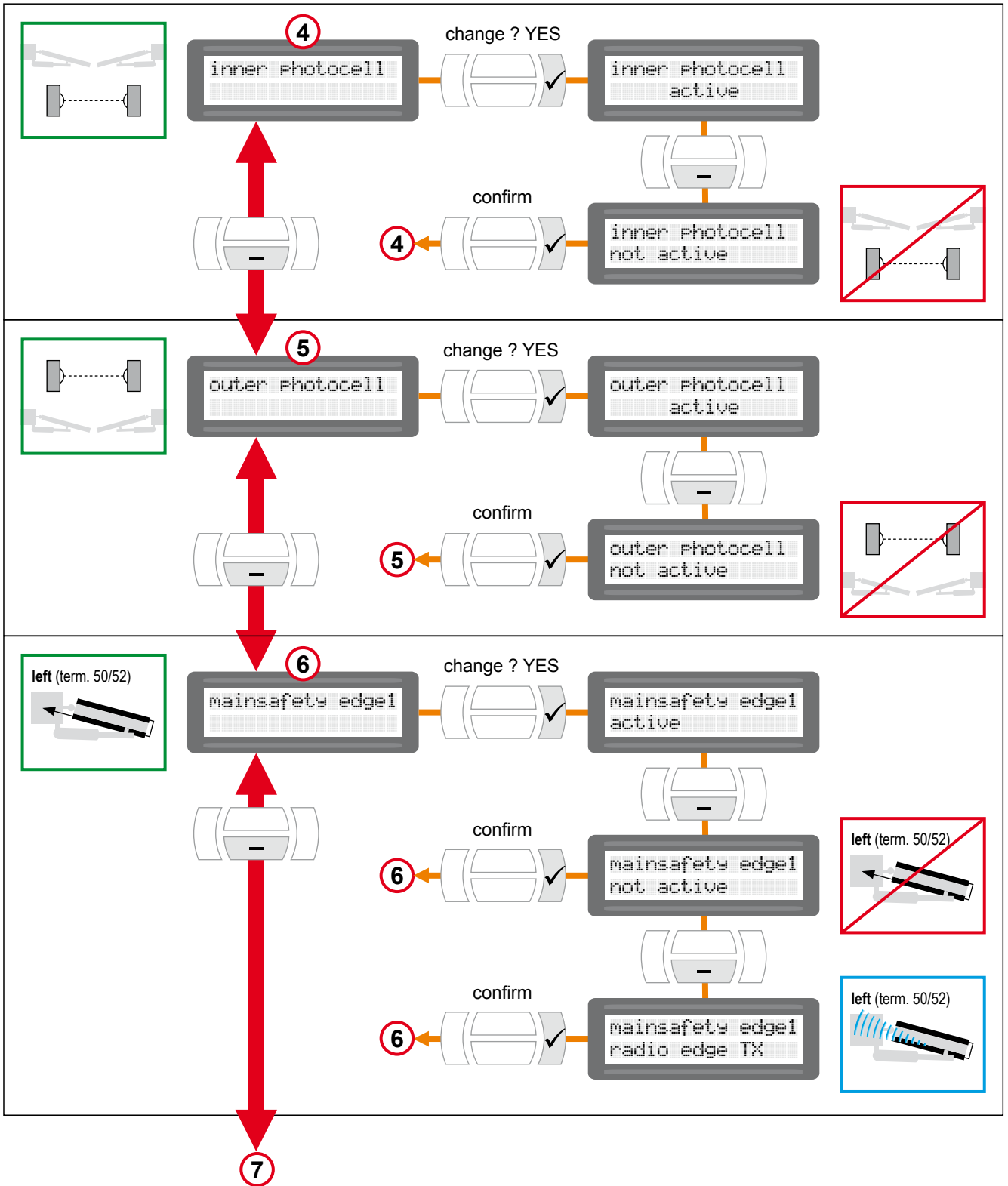

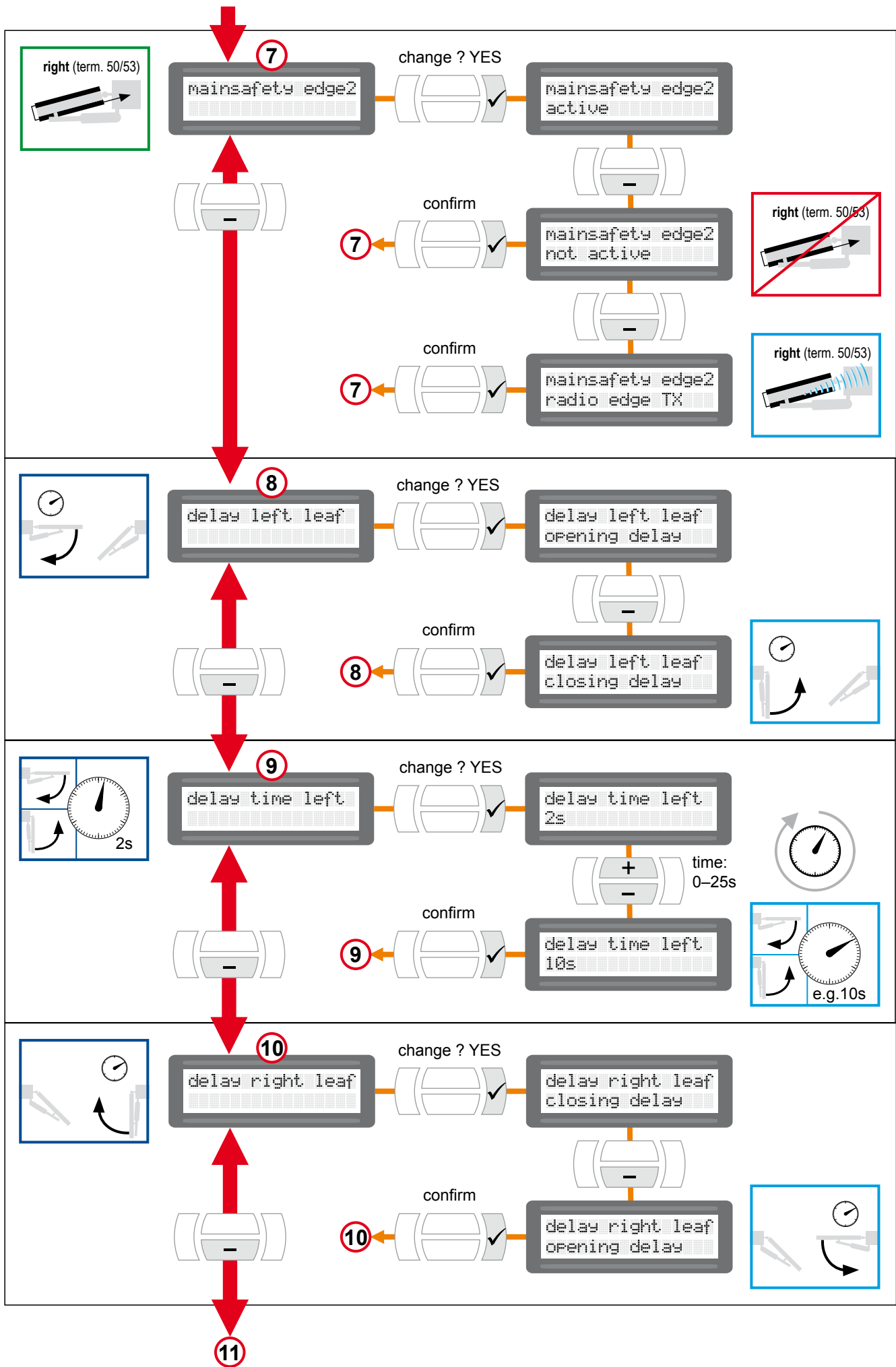



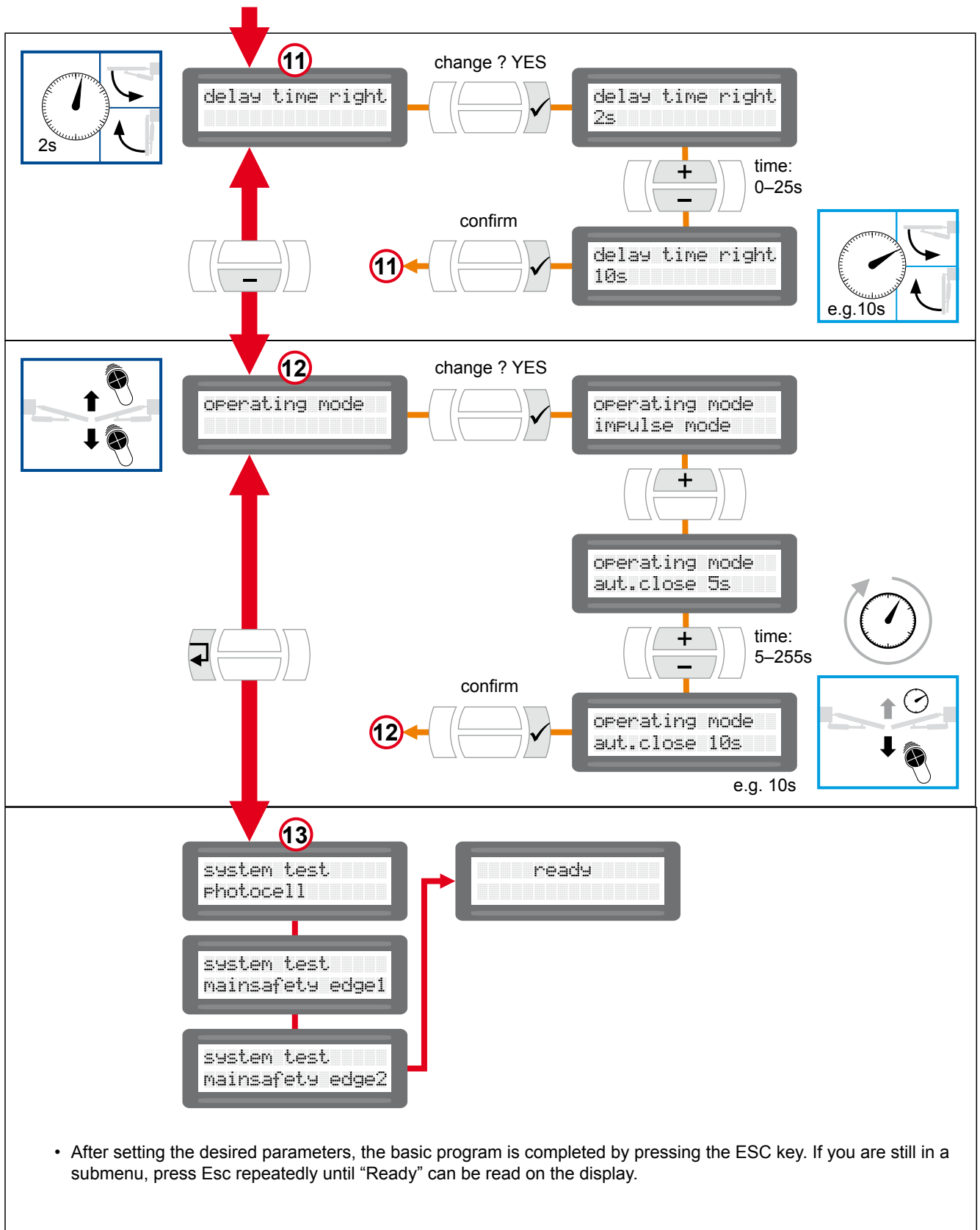

## Important

- The gate installation (1 or with 2 leaves) has to reflect in the settings of the main menu !
- Factory setting: Operation of swing gate with 2 gate leaves, the left and right operator are turned on in main menu: „☉ Motor ON“.
- **IMPORTANT:** With 1 leaf gate installation, only the operator of the actually existing gate leaf must be activated in the main menu, the other one has to be disabled (deactivated) !  
(In Main Menu: Left(Right) leaf / Motor / „Motor OFF“)

Error	possible reason	solution
No reaction after emitting a command	mains voltage missing or fuse F1 defective	control of mains voltage as well as of fuse F1
	Display: error stop button	check if stop button is properly connected or bridged
Control relays switch but motor does not run	connection between motor and control defective	check supply lines
Gate opens but does not close	photocell interrupted	check positioning and functions of photocells
Gate opens but does not close completely	force regulation not strong enough	adjust force
	total runtime too low	increase runtime
safety sensing edge 1 or 2 actuated	adjustment of safety sensing edges wrong	remove obstacle or function control via status display
No reaction of radio receiver	radio receiver plugged into wrong connector	check proper installation <i>see connection of radio receiver</i>
	no / wrong connected antenna	check antenna connection
	radio transmitter not programmed	program handheld transmitter
Display shows: BROWN OUT	undervoltage	call service technician

- dimensions in mm



We reserve the right to change dimensions and technical specifications without prior notice.

## **tousek PRODUCTS**

- sliding gate operators
- cantilever systems
- swing gate operators
- garage door operators
- folding door operators
- traffic barriers
- carpark management system
- window operators
- domelight operators
- sliding door operators
- electronic controls
- radio remote controls
- key operated switches
- access control
- safety devices
- accessories

**Tousek Ges.m.b.H. Austria**  
A-1230 Vienna  
Zetschegasse 1  
Tel. +43/ 1/ 667 36 01  
Fax +43/ 1/ 667 89 23  
info@tousek.at

**Tousek GmbH Germany**  
D-83395 Freilassing  
Traunsteiner Straße 12  
Tel. +49/ 8654/ 77 66-0  
Fax +49/ 8654/ 57 196  
info@tousek.de

**Tousek GmbH Switzerland**  
CH-6275 Ballwil  
Bahnhofstraße 14  
Tel. +41/ 0/ 41 448 2965  
Fax +41/ 0/ 41 448 2966  
info@tousek.ch

**Tousek Benelux NV**  
BE-3930 Hamont - Achel  
Buitenheide 2A/ 1  
Tel. +32/ 11/ 91 61 60  
Fax +32/ 11/ 96 87 05  
info@tousek.nl

**Tousek Sp. z o.o. Poland**  
PL 43-190 Mikołów (k/Katowic)  
Gliwicka 67  
Tel. +48/ 32/ 738 53 65  
Fax +48/ 32/ 738 53 66  
info@tousek.pl

**Tousek s.r.o. Czech Republic**  
CZ-130 00 Praha 3  
Jagellonská 9  
Tel. +420/ 2/ 2209 0980  
Fax +420/ 2/ 2209 0989  
info@tousek.cz

**tousek**  
E\_ST51\_04  
11. 05. 2015



*your service partner:*

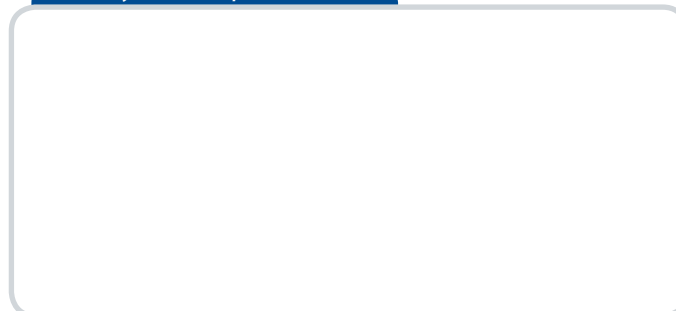

We reserve the right to change dimensions and/or technical specifications without prior notice. Claims resulting from misprints or errors cannot be accepted.

