



Sliding Gate Opener

User's Manual

Model:

DK1000(S/Y/T)

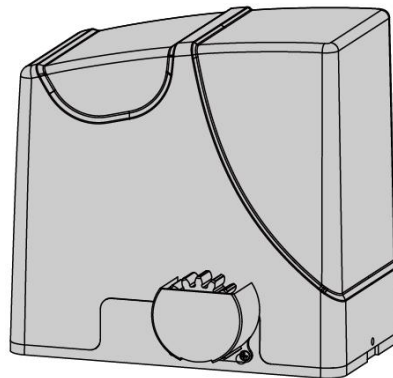

TOPENS Website

www.topens.com

Email: support@topens.com

- ★ Please read and follow all warnings, precautions and instructions before installation and use.
- ★ Never connect the solar panel to the control board directly to charge the battery.
- ★ Periodic checks of the opener are required to ensure safe operation.
- ★ Save this manual.



CONTACT US:

Visit: www.topens.com

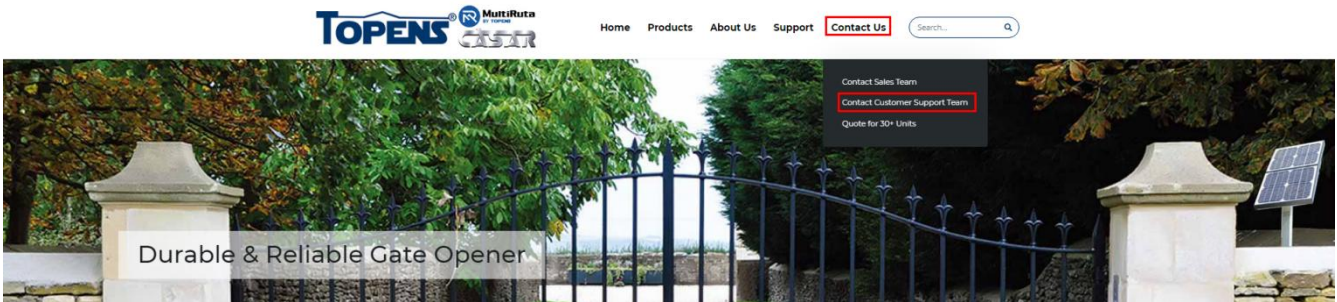

Please record the product model, your email address etc.

in the spaces provided below. Refer to this list when contacting TOPENS for technical service or assistance with your automatic gate opener.

Where did you purchase? (Amazon.com; Amazon.ca: Amazon.co.uk, Amazon.de; Other, Please Specify)

Order#	Product Model	Purchase Date
Full Name	Phone#	Email Address (VERY IMPORTANT)
Street Address, Apartment /Unit, City, State /Province, Zip Code		Country/Region
Approximate Gate Weight (pounds; kg: Other. Please Specify)	Approximate Gate Length (feet; meter; Other. Please Specify)	Did you purchase any accessories? (Please list below)

Issue Details

Email Us: support@topens.com

Call: +1 (888) 750 9899 (Toll Free USA & Canada)

Table of Contents

Check Your Gate before Installation	1
General Safety	1
Preparation for Installation	2
Parts List	4
Extra Parts	4
Accessories Parts (Included in some models, refers to the actual package)	4
Optional Accessories Parts List (Available at TOPENS Store)	5
Replacement Parts	5
Technical Specifications & Features	6
Installation Overview	6
Installation of the Opener	7
Manual Operation	7
Fit the Rack	8
Installation of the Magnets	9
Connection of the Power Supply	9
Connecting of the Control Board	12
Setting of the Control Board	14
Test the Reversing Sensitivity	16
How to Use the Remote to Operate Your Gate Opener	17
Wireless Keypad Programming	17
Maintenance	19

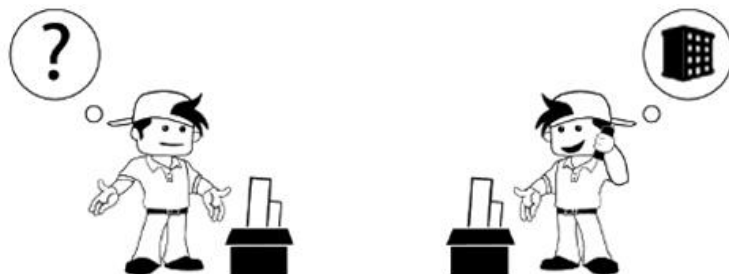

I Ask for TOPENS help by E-mail or phone anytime.

Thank you for purchasing our sliding gate opener. We are sure that the products will be greatly satisfying as soon as you start to use it.

The product is supplied with a user's manual which encloses installation and safety precautions. These should be read carefully before installation and operation as they provide important information about safety, installation, operation and maintenance. This product complies with the recognized technical standards and safety regulations.

Check Your Gate before Installation

CHECK YOUR GATE

Before installation, please make sure that the gate itself can be opened and closed smoothly & freely BY HAND WITHOUT THE GATE OPENER.

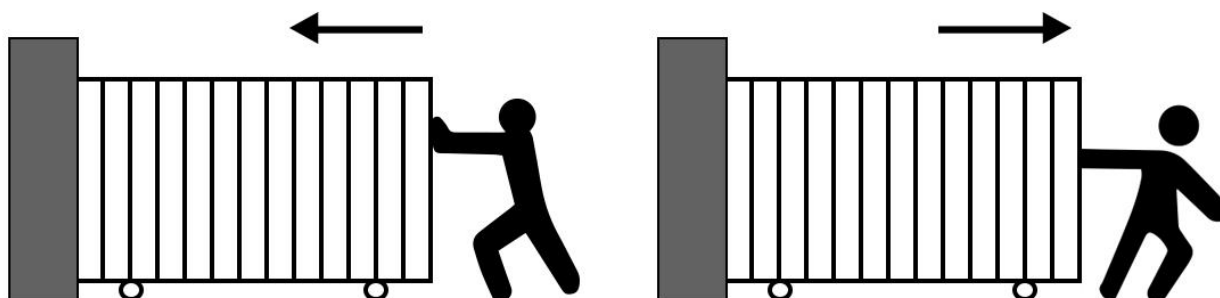

General Safety



WARNING! An incorrect installation or improper use of the product can cause damage to persons, animals or properties.

- Scrap packing materials (plastic, cardboard, polystyrene etc.) according to the provisions set out by current standards. Keep nylon or polystyrene bags out of children's reach.
- This product was exclusively designed and manufactured for the use specified in the present documentation. Any other use not specified in this documentation could damage the product and be dangerous.
- The factory declines all responsibility for any consequences resulting from improper use of the product, or use which is different from that expected and specified in the present documentation.
- Do not install the product in explosive atmosphere.
- The factory declines all responsibility for any consequences resulting from failure to observe Good Technical Practice when constructing closing structures (door, gates etc.), as well as from any deformation which might occur during use.
- Disconnect the electrical power supply before carrying out any work on the installation. Also disconnect any buffer batteries, if fitted.
- Fit an omnipolar or magnetothermal switch on the mains power supply, having a contact opening distance equal to or greater than 3,5 mm.
- Make sure a residual current circuit breaker with a 30mA threshold is fitted before the power supply mains.
- Check that earthing is carried out correctly: connect all metal parts for closure (doors, gates etc.) and all system components provided with an earth terminal.
- Fit all the safety devices (photocells, electric edges etc.) which are needed to protect the area from any

danger caused by squashing, conveying and shearing.

- Position at least one visible indication device (Alarm lamp), and fix a Warning sign to the structure.

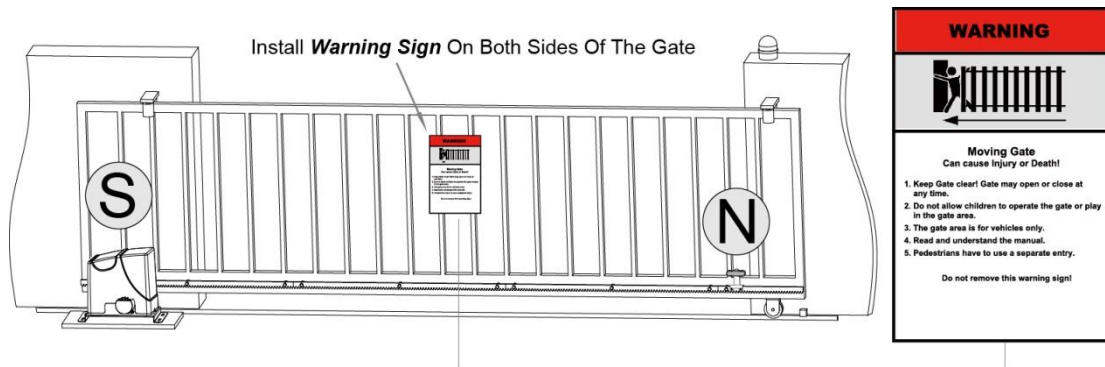

- The factory declines all responsibility with respect to the automation safety and correct operation when other supplier's components are used.
- Only use original parts for any maintenance or repair operation.
- Do not modify the automation components, unless explicitly authorized by the factory.
- Instruct the product user about the control systems provided and the manual opening operation in case of emergency.
- Do not allow persons or children to remain in the automation operation area.
- Keep radio control or other control devices out of children's reach, in order to avoid unintentional automation activation.
- The user must avoid any attempt to carry out work or repair on the automation system, and always request the assistance of qualified personnel.
- Anything which is not expressly provided for in the present instructions is not allowed.
- Before installing the gate opener, check that all moving part as well as the sliding gate is in good mechanical condition, correctly balanced and opens and closes properly.
- Save these instructions for future use.

Preparation for Installation

Before proceeding to your opener installation, check if your gate structure is in accordance with the current standards, especially as follows:

The gate sliding track is linear and horizontal. The wheels are suitable for use. The gate should be mounted and moved freely. Check that the structure is sufficiently strong and rigid, and that its dimensions and weights conform to those listed in the specifications table of this document. Make sure that the gate is plumb and level. The fence posts must be mounted in concrete. The gate does not bind or drag on the ground.

- The gate manual operation can be carried out smoothly along its entire run, and there is no excessive side slipping.
- The opening and closing gate stops are positioned.



WARNING: Remember that control devices are intended to facilitate gate operation, but can not solve problems due to any defects or deficiency resulting from failure to carry out correct installation or maintenance. Take the product out of its packing and inspect it for damage. Should it be damaged, contact your dealer. Remember to dispose of its components (cardboard, polystyrene, nylon, etc.) according to the current prescriptions.

Refer to the following Figures for gate installation.

Using the post or wall as a stop, either directly or indirectly, is not recommended so as to protect the post or wall against damaging shock from the sliding gate.

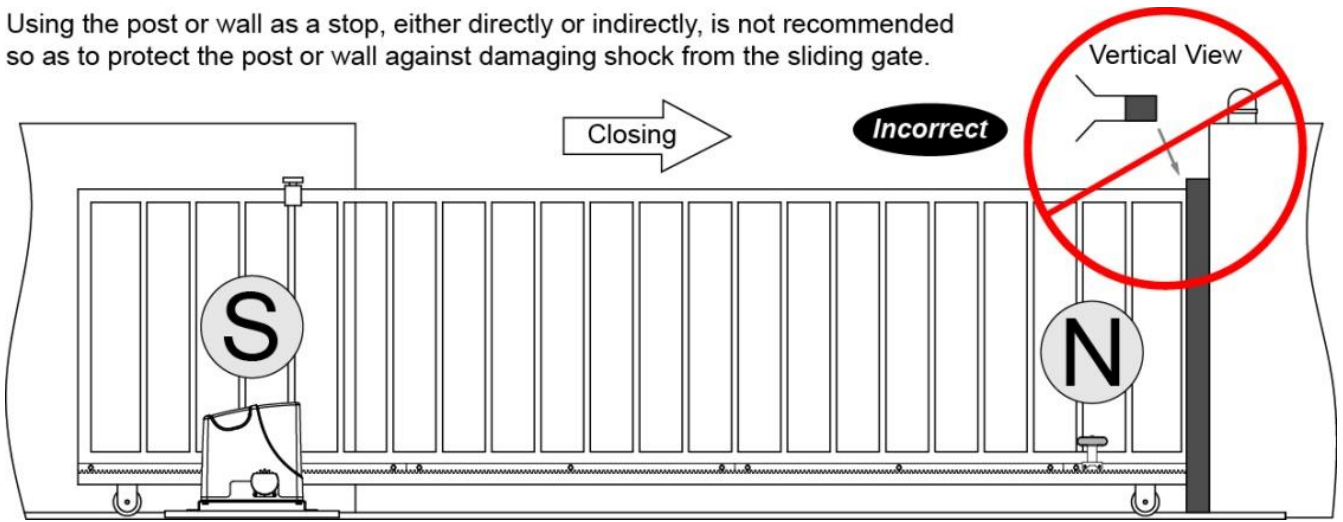

In sake of safety, a positive stop must be mounted on the two end of ground track.

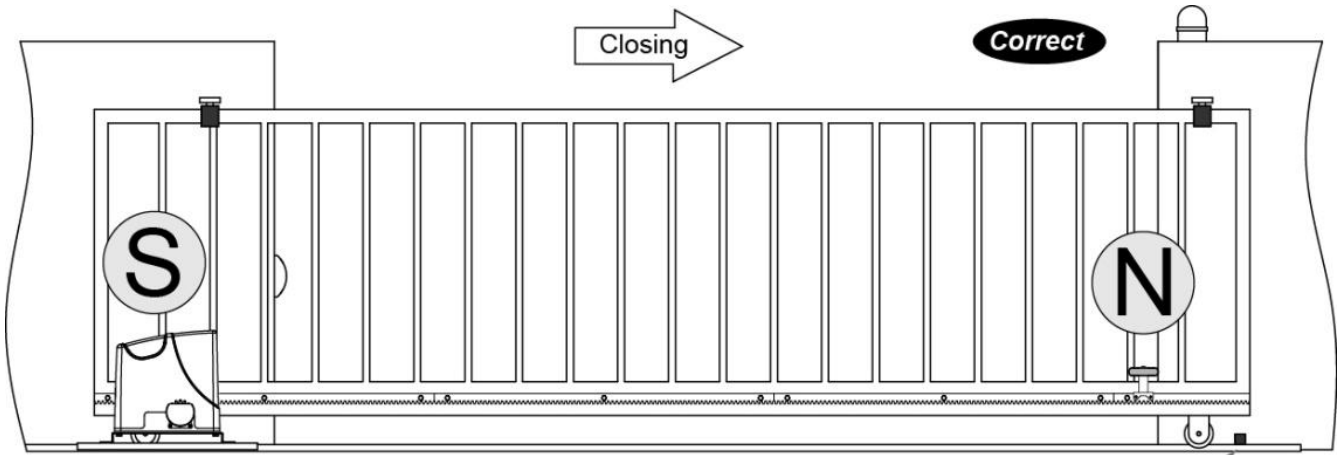





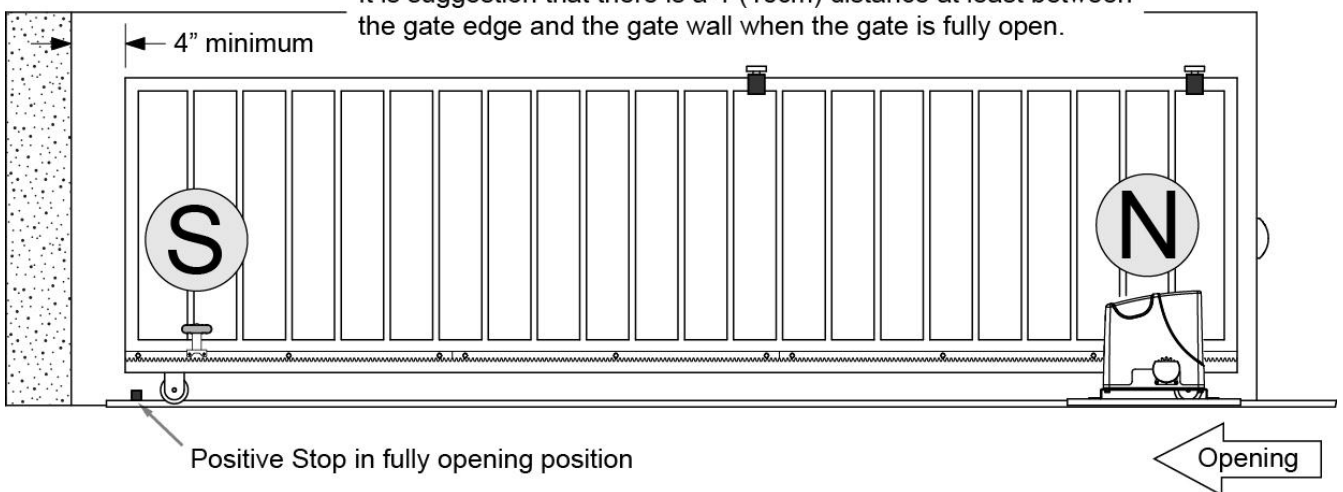





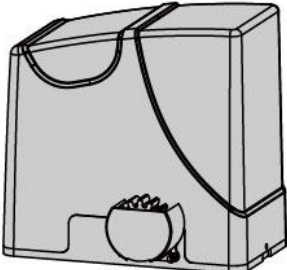





Positive Stop in fully closed position

It is suggestion that there is a 4" (10cm) distance at least between the gate edge and the gate wall when the gate is fully open.





Positive Stop in fully opening position

Parts List

 Gate Opener (1 pc)	 Remote Control (2 pcs)	 Anchor Bolt (4 pcs)	 Warning Signs (2 pcs)
	 Release Key (1 pc)	 Base Plate (1 pc)	
 Magnet Bracket (2 pcs)	 Magnet Assembly (N pole) (1 pc)	 Φ10 Washer (4 pcs)	 Φ8 Washer (4 pcs)
	 Magnet Assembly (S pole) (1 pc)	 Φ10 Lock Washer (4 pcs)	 Φ8 Lock Washer (4 pcs)
	 Pan Head Screw M5×12 (8 pcs)	 M10 Nut (4 pcs)	 M8×30 Bolt (4 pcs)

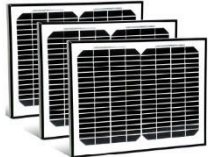
Extra Parts

Included in S Series		Included in Y Series	Included in T Series
 TCS3 Solar Charge Controller (1 pc)	 10W Solar Panel (3 pcs)	 12V/7.2AH battery (2 pcs)	 Plastic Rack (12pcs total 4m)



Accessories Parts (Included in some models, refers to the actual package)

 JD24VY 24V Warning Light	 TC102 Photo Eye Beam Sensor
---	--

Optional Accessories Parts List (Available at TOPENS Store)

 <p>M12 Remote Control</p>	 <p>ERM12 External Receiver</p>	 <p>TC186-R WiFi Smartphone Remote Control with Camera</p>	 <p>TC188 Universal Wireless and Wired Keypad</p>
 <p>TKP3 Wireless Keypad</p>	 <p>TC175P Wired Keypad</p>	 <p>TEW3 Vehicle Sensor Exit Wand</p>	 <p>HLR01 HomeLink Remote Control Kit</p>
 <p>TC173 Wireless Push Button</p>	 <p>TC147 Wall Push Button</p>	 <p>TC148 Waterproof Wall Push Button</p>	 <p>TRF3 Reflection Photocell Sensor</p>
 <p>TC102 Photo Eye Beam Sensor</p>	 <p>JD24VY 24V Warning Light</p>	 <p>TSP30W 30W Solar Panel Charging Kit</p>	 <p>TSQ20W 20W Solar Panel Kit</p>
 <p>TCS3 Solar Charge Controller</p>	 <p>RNH4 Heavy Duty Gear Rack</p>	 <p>RNH2 Heavy Duty Gear Rack</p>	 <p>SR02 Heavy Duty Steel Gear Rack</p>

Replacement Parts

 <p>DKPYMJ2A Control Board</p>	 <p>PYMJ-CKG Limit Switch</p>
---	--

WARNING: Changes or modifications not expressly specified by this user manual, TOPENS could void the warranty of this equipment.

Technical Specifications & Features

Specifications	
Model:	DK1000(S/Y/T)
Power supply:	110V~120V/60Hz or 220~240V/50Hz
Motor voltage:	24VDC
Absorbed power:	350W
Gate moving speed:	20 cm/s (8 in/s)
Max gate weight:	800kg (1800lbs)
Max torque:	16Nm
Environmental conditions:	-20°C ~ +50°C (0°F to 120°F)
Protection class:	IP44

Features:

- Soft start and soft stop
- Midway mode.
- Quick selection for the gate open/close direction
- Reliable rolling code technology for remote control
- Emergency release key in case of power failure
- Stop in case of obstruction during gate opening
- Reverse in case of obstruction during gate closing
- Built in adjustable auto-close (none, 30, 60, 90 seconds)
- Built in max. Motor Running Time (MRT) for multiple safety protection (90 seconds)
- Reliable electromagnetism limit for easy adjustment
- Can be equipped with a wide range accessories
- Easy to install, and minimum maintenance requirement

Installation Overview

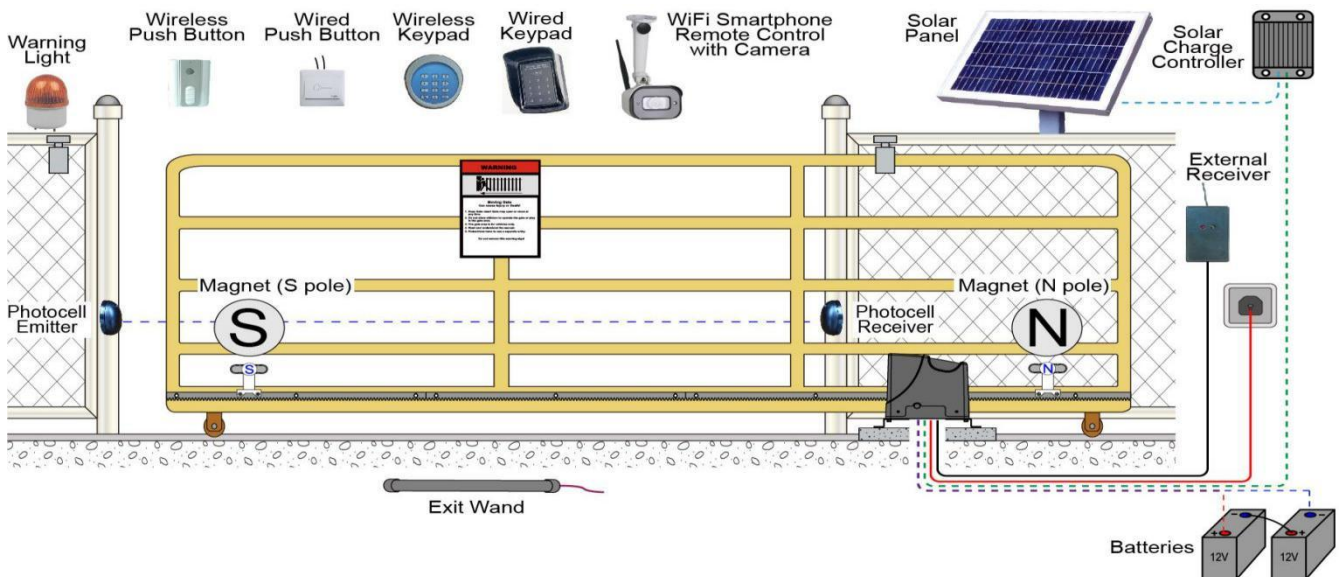

Installation of the Opener

Caution:

*Be sure that the opener is installed in a horizontal and paralleled position and is properly secured. Improper installation could result in property damage, severe injury, and/or death.

* Before starting installation, ensure that there is no point of friction during the entire movement of the gate and there is no danger of derailment.

* Ensure that the **Warning Signs** are present.

Necessary Tools: The following tools may be necessary to install the Gate opener. You will need screwdrivers, an electric drill, wire cutters and a wire stripper, a socket set, and possibly access to a welder.

When install the opener, you should build a concrete pad to support the base plate of opener in order to maintain proper stability.

The installation proceeds are as follows:

1. Dig a hole for a concrete pad which should be approximately 600 x 320 x 350mm (24" x 13" x 14"). It may protrude 100mm (4") above ground and 250mm (10") in depth underground. Increase the pad height if necessary to protect the system from flooding, heavy snow etc.

2. Prepare one or more conduits for the electrical cables before pouring concrete. Remember that cable conduits have to pass through the hole in the base plate.

3. Pour concrete and before it starts to harden, check that it is parallel to the gate leaf and perfectly level.

4. The four anchor bolts must be set into the concrete when it is poured, make sure the position of anchor bolts was placed according to the position of mounting holes on the base plate before concrete become harden.

5. Mount the base plate to the concrete pad.

6. Place the opener onto base plate. Check that it is perfectly parallel to the gate, and then screw the four bolts and washers supplied. It's only temporary installation. Further adjustment will be required when install the rack.

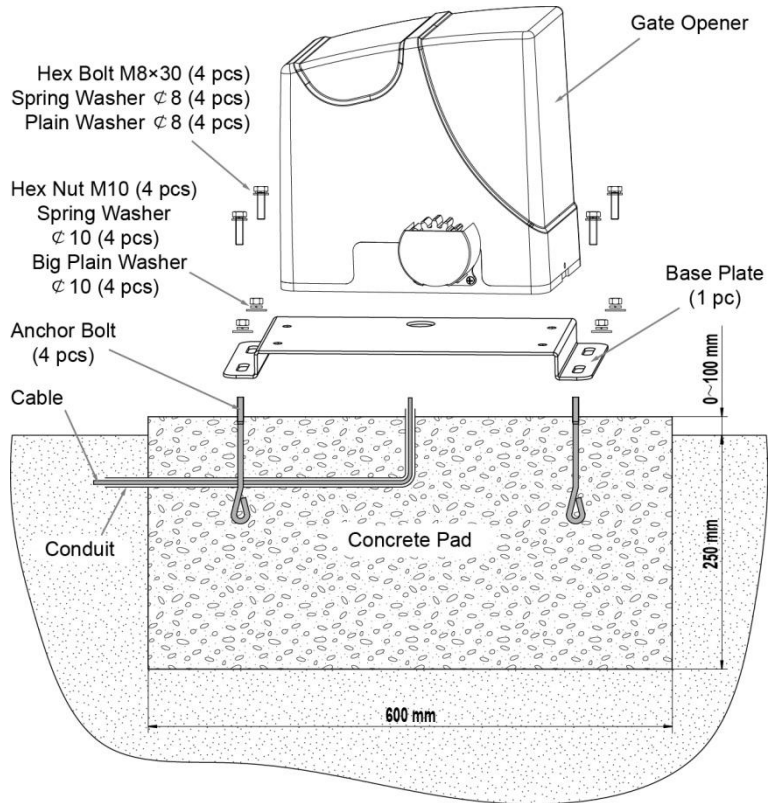

Manual Operation

The opener should be put in the manual (emergency release) position before fitting the rack, installing the opener and limit switch. The process is as follows:

- 1) Take off the rubber stopple.
- 2) Insert the Release Key (provided) and turn it in clockwise four turns to disengage the clutch between the gear shaft and power output. Now the opener is in the manual operation.



Fit the Rack

There are two kinds of rack available as per your options, which are steel reinforced plastic rack and galvanized steel rack. The galvanized steel rack is usually used for the heavy duty gate.

A. Fit the plastic rack reinforced with steel

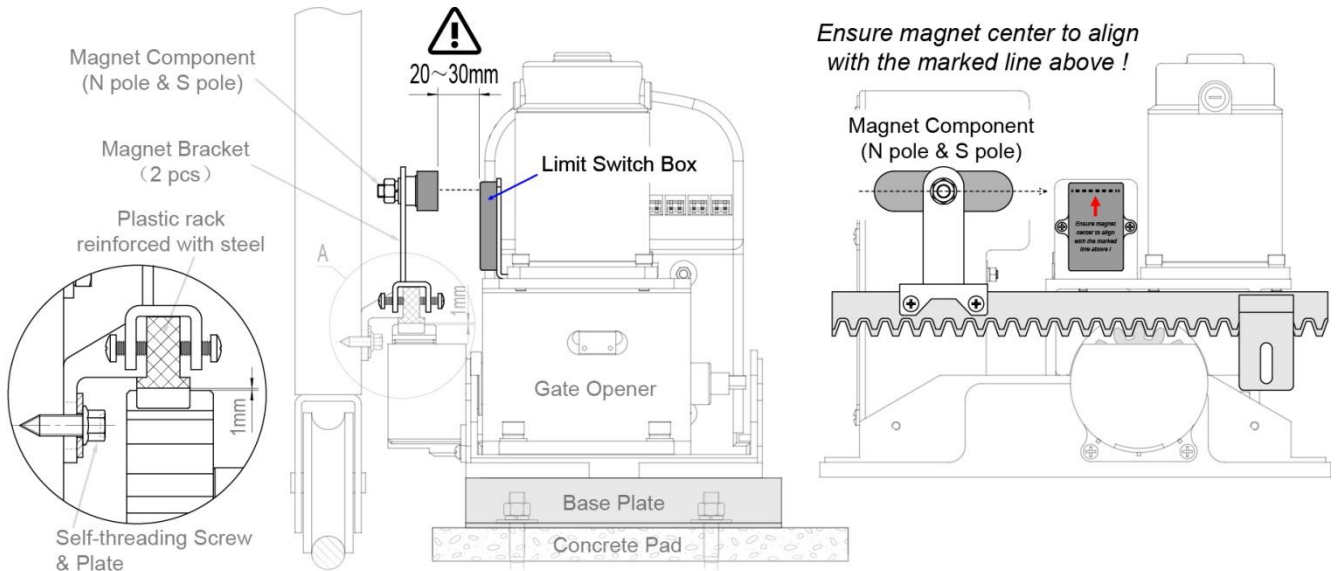

1. Start with gate in closed position
2. Prepare the plastic rack (you can order extra rack from dealer if necessary).
3. Put one end of rack section on the gear of opener as a temporary support. Make rack level and mark the rack's mounting holes (**four holes for light duty or six holes for heavy duty**) on the gate.
4. Fit the rack by self-threading screws. This kind of plastic rack is quieter and allows height adjustments to be made even after it has been fixed. Please keep 1.0mm space between the rack and the gear to avoid the weight of the gate effect on the opener.

B. Fit the galvanized steel rack

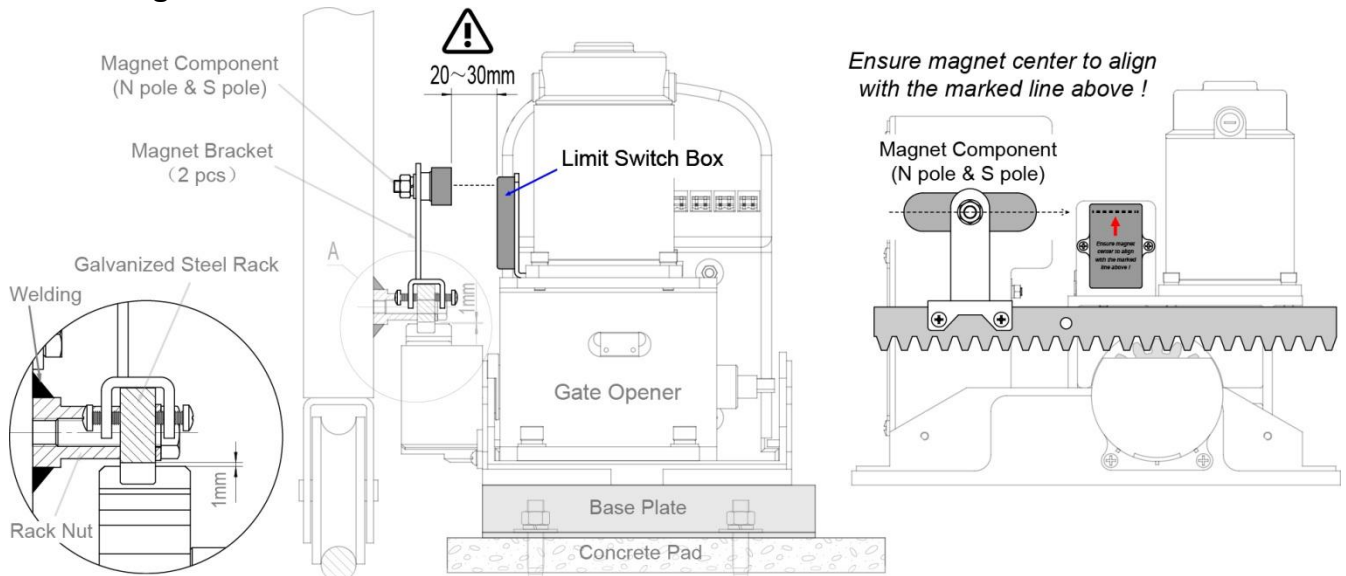

1. Start with gate in closed position
2. There are four sections of steel rack which is one meter length. (you can order extra rack from dealer if necessary)
3. Put one end of rack section on the gear of opener as a temporary support.

Make rack level and mark the rack's mounting holes (**three holes**) on the gate.

4. Weld the rack nut on the gate as mark and connect the rack to the gate using the bolt provided. Before weld, please keep 1.0mm space between the rack and the gear to avoid the weight of the gate effect on the opener.

Installation of the Magnets

Before install limit switch, make sure the gate opener is put in manual operation. (the clutch connected with gear shaft is disengaged) and the mains power supply is disconnected.

Position the S&N Magnet Components approximately on the gate and move the gate by hand to fix them in place.

Fit magnets bracket

Push the gate fully closed by hand. Locate and install the magnet bracket so that the opener will stop at the desired close position when the close limit switch approaches it.

Push the gate fully open by hand. Locate and install the magnet bracket so that the opener will stop at the desired open position when the open limit switch approaches it.

The magnet component with S pole outside must be installed at left side and the magnet component with N pole outside must be installed at right side from the view inside of property.

Ensure magnet center to align with the marked line above !

The magnets should be **20~30mm (0.8-1.2")** away from the **Limit Switch Box**. If it is too near or too far, the switches will fail to work. Adjust the position of the magnets until the positions of the opening and closing meet the requirement.

Warning: Improper magnets installation may cause the gate crash into end barrier, which is very dangerous !

Important:

* Check that the rack teeth must engage the gear teeth throughout their full thickness. If not, adjust the position of the opener or/and place a few shims between the rack and gate.

* Manually slide the gate leaf to ensure the rack is proper on the gear of opener.

* Repeat same steps of first rack section to install the rest rack sections until proper length is reached.

* Cut away any excess of the rack (Note: rack length must be longer than actual travel of the gate)

* Thoroughly fasten the four nuts as well as spring washers onto expansion bolts tightly, enabling the opener is firmly secured on the concrete pad during the whole gate travel.

Connection of the Power Supply

⚠ WARNING: NEVER connect the gate opener to the power outlet before all the installations have been done.

NOTE:

1. If batteries are chosen as the power source, Marine or Automotive Type Battery is required. The batteries should be waterproof type, or be placed in water proof circumstance.

2. 2 PCS 12VDC batteries can be connected in series to function as 24VDC. The following diagram shows on how to connect 2 PCS batteries in series.

3. Please note that the wire connection of the power supply system is very important. Incorrect wire connection will damage the control board.

Power Mode 1. Only use the AC electricity as the power source

The power supply cord should be at least 3×0.75mm² (3C×18AWG). Connect the live wire, neutral wire and earth wire to the “L”, “N” and “PE” terminals respectively.

NOTE: The power supply cord is not included in the package.

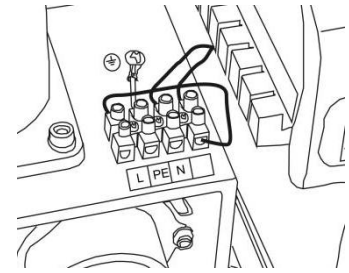

Power Mode 2. By AC electricity and back-up

batteries, only use the AC electricity to charge the batteries

If the AC electricity failure happens rarely (less than 8 hours per day), then you can use minimum 5Ah 2*12VDC batteries as back-up power source in case of AC power failure. In this situation, you can connect the AC electricity following the “Power Mode 1” and the batteries to the BAT terminal of the control board directly as the below wiring diagram.

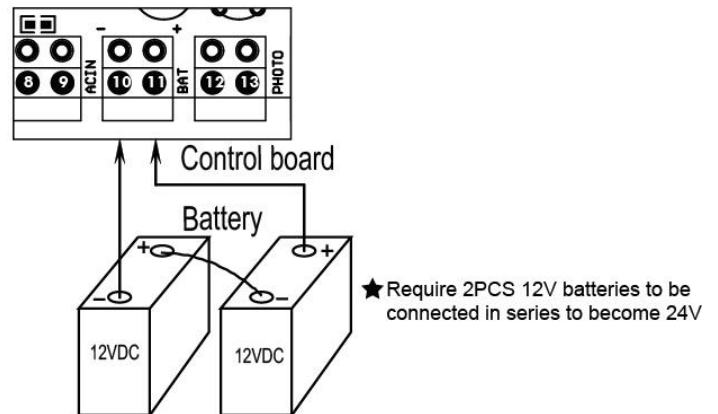

Power Mode 3. Only use the batteries as the power source, only use the solar panel to charge the batteries

If the AC electricity is not available, then you can choose the batteries as the power source and use the solar panel to charge the batteries. The capacity of the batteries should be at least 12Ah and the power of the solar panel should be at least 30W in this situation. The gate opener can run for 10 cycles per day without connecting any other accessories except pushbutton & warning light if the local average sunshine time is more than 6 hours per day. The power of the solar panel and the capacity of the batteries should be enlarged if the local average sunshine time is less than 6 hours per day or using one of the accessories (photocell, external receiver, exit wand and keypad). Please provide us with more details of the local sunshine condition and accessories needs which we can calculate the configuration of the solar panel and the batteries. Please connect the batteries & the solar panels & solar controller refer to the following wiring diagram.

Connecting of the Control Board

1. Motor

The **YELLOW** wire of the motor should be connected into the “1” terminal.

The **RED** wire of the motor should be connected into the “2” terminal.

2. Limit Switches

The **YELLOW** wire of the limit switches should be connected into the “3” terminal.

The **BLACK** wire of the limit switches should be connected into the “4” terminal.

The **RED** wire of the limit switches should be connected into the “5” terminal.

3. Warning Light (Included in some models, refers to the actual package)

The **WHITE** wire of the warning light should be connected into the “6” terminal.

The **RED** wire of the warning light should be connected into the “7” terminal.

4. Photocell Beam System (PBS) (Included in some models, refers to the actual package)

Use a 2-core cable to connect the “- ~” terminal of the photocell’s emitter to the “19” terminal, the “+ ~” terminal to the “18” terminal. Also the “- ~” and “+ ~” terminals of the photocell’s receiver should be connected to the “19” and “18” terminals in parallel.

Use another 2-core cable to connect the “**NC**” terminal of the receiver to the “13” terminal, the “**COM**” terminal to the “12” terminal.

5. Reflection Photocell Sensor (optional)

The “**AC10-25V/DC12-30V**” terminals of the reflection photocell sensor should be connected to the “18” and “19” terminals, no matter the polarity.

The “**NC**” terminal should be connected to the “13” terminal.

The “**COM**” terminal should be connected to the “12” terminal.

★ Please note that the photocell terminal must be shorted if the photocell beam system is not used. A wire jumper has been used for short the terminal in factory.

★ Please check if this wire jumper is missing or keep the photocell in alignment when the gate can open but fails to close.



6. Push Button (optional)

The push button should be wired to the “16 and “17” terminals. No matter the polarity. The gate operator works alternately by pressing the button (open-stop-close-stop-open).

7. Exit Wand (optional)

The **BLACK** wire of the exit wand should be connected into the “14” terminal.

The **BLUE** wire of the exit wand should be connected into the “15” terminal.

The **RED** wire of the exit wand should be connected into the “18” terminal.

The **GREEN** wire of the exit wand should be connected into the “19” terminal.

The sensitivity adjustment board should be wired to the **GREEN** wire and the **YELLOW** wire of the wand. No matter the polarity.

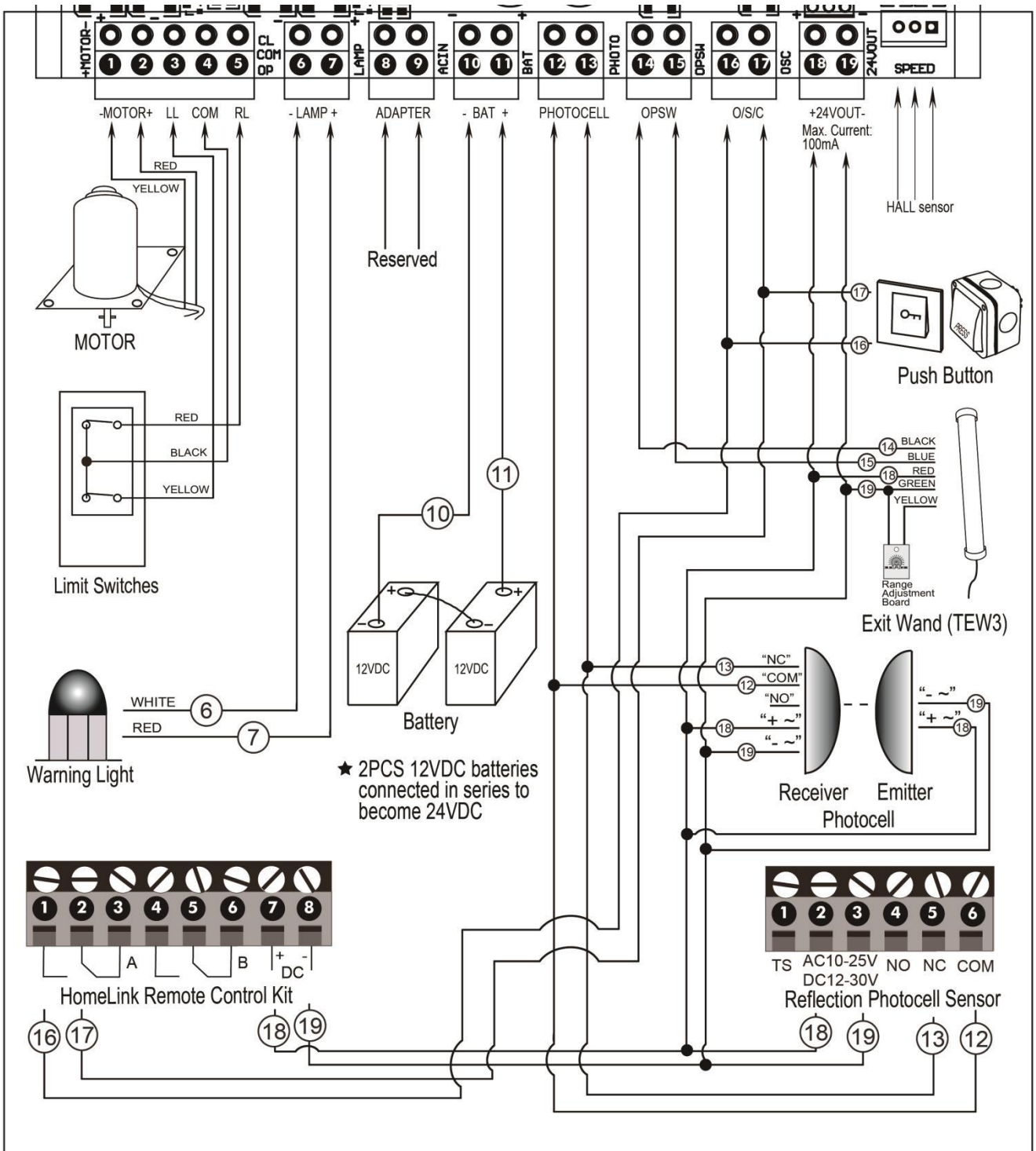

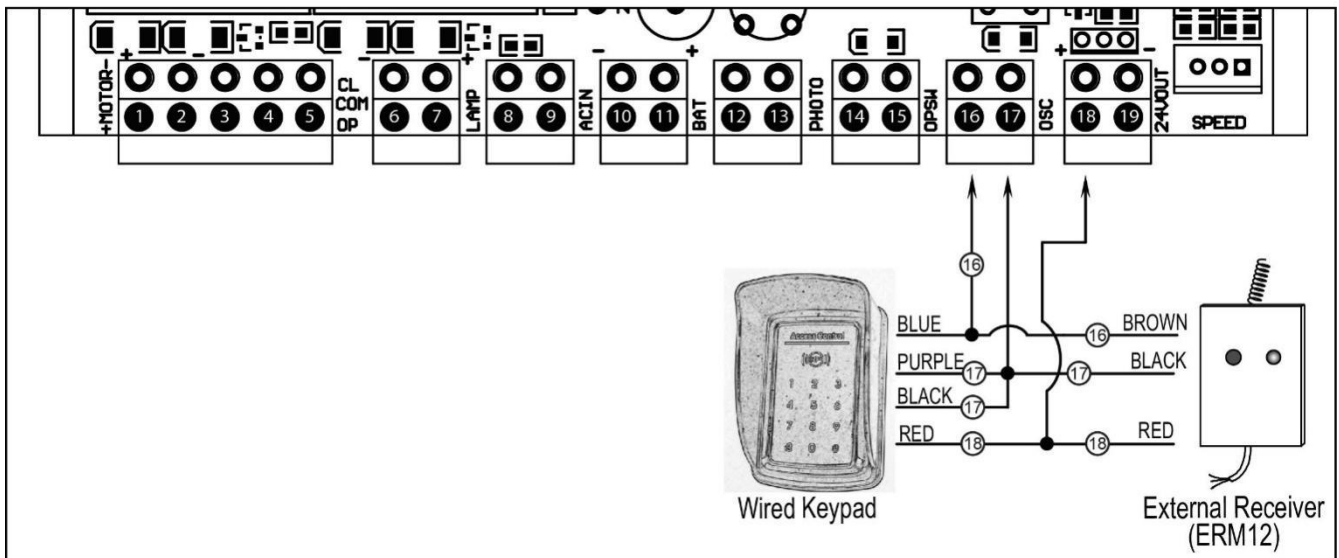

8. Battery (ONLY included in Y Series)

The “24V+” of the battery should be wired to the **BAT+** (11) terminal, “24V-” should be wired to “**-BAT**” (10) terminal. If the battery has been used with solar panel, please connect the batteries and the solar panel & solar controller following the chapter of “**Connection of the Power Supply**”.

9. External Receiver (optional)

The **BROWN** wire of the external receiver should be connected into the “16” terminal.

The **BLACK** wire of the external receiver should be connected into the “17” terminal.

The **RED** wire of the external receiver should be connected into the “18” terminal.

10. Wired Keypad (24VDC) (optional)

The **RED** wire of the wired keypad should be connected into the “18” terminal.

The **BLACK** wire of the wired keypad should be connected into the “17” terminal.

The **BLUE** wire of the wired keypad should be connected into the “16” terminal.

The **PURPLE** wire of the wired keypad should be connected into the “17” terminal.

11. HomeLink Remote Control Kit (optional)

The “1” terminal should be connected to the “16” terminal.

The “2” terminal should be connected to the “17” terminal.

The “DC+” terminal should be connected to the “18” terminal.

The “DC-” terminal should be connected to the “19” terminal.

NOTE: Using of the photocell, exit wand, keypad and external receiver would cause the battery exhausted quickly. Big capacity of batteries and big power of solar panel is required if you want to use any one of them (If the batteries and solar panel is used as main power supply).

Setting of the Control Board

⚠ WARNING: Ensure the gate opener is Power Off when you make any adjustment of the gate opener. Keep away from the path of the gate during you set the gate opener system in case of the unexpected gate moving. Carefully adjust the DIP switches to avoid the risk of machine damage and injury or death. Always ask the help of professional technician /electrician if you have any question.

1. DIP Switches

The DIP switches are used to set the running time of the motor in midway mode, fine adjust the soft stop period of the motor, auto close time of the gate opener and

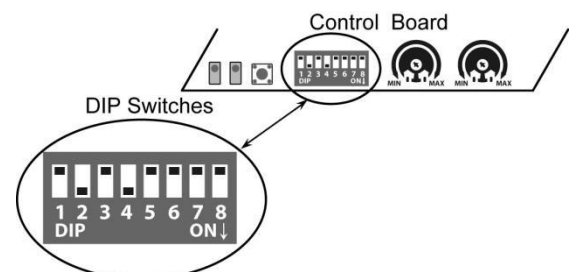

fast change the open/close direction which is determined by the position of the gate opener installed.

DIP Switch #1–#2: Running time of the motor in Midway Mode

DIP Switch #1: ON – 2 Seconds OFF – 0

DIP Switch #2: ON – 4 Seconds OFF – 0

NOTE: The midway mode function would be disabled if both DIP switches are turned off. Factory default setting is disabled. The midway mode could be activated by pressing button B of the remote control when the gate is in the full closed position.

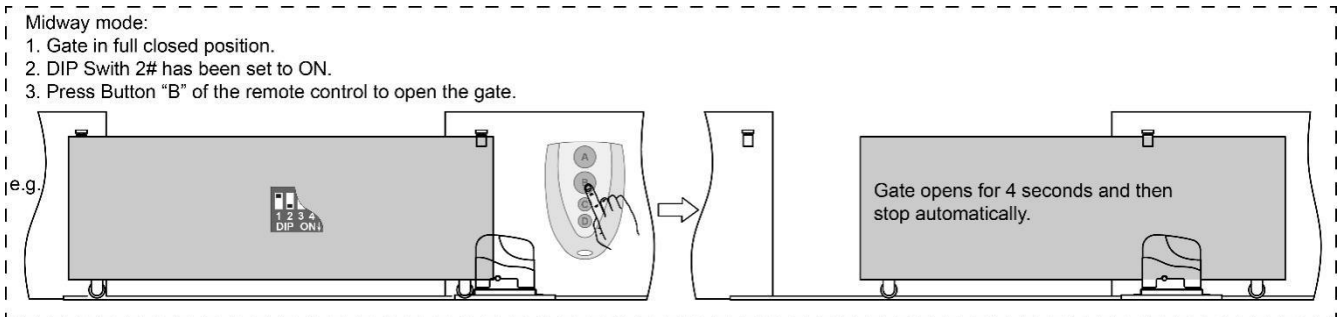
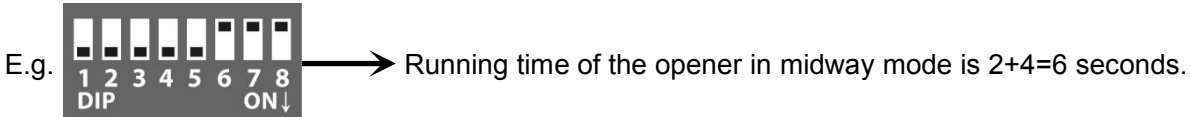

DIP Switch #3–#5: Fine adjust the soft stop period of the motor

DIP Switch #3: ON – 1 Second OFF – 0

DIP Switch #4: ON – 2 Seconds OFF – 0

DIP Switch #5: ON – 3 Seconds OFF – 0

NOTE: Every time you restart the gate opener after power off, you should use the access control device (such as remote, push button and etc.) to operate the gate opener to run for a complete opening cycle and a complete closing cycle to get the full opening time and the full closing time. You would achieve the soft stop in your next opening/closing cycle. Factory default soft stop time is 3 Second. You can turn the DIP switches on/off to fine adjust the soft stop time to meet your actual needs.

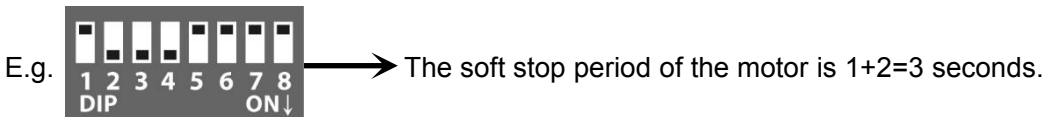

DIP Switch #6–#7: Auto close time of the gate opener

DIP Switch #6: ON – 30 Seconds OFF – 0

DIP Switch #7: ON – 60 Seconds OFF – 0

NOTE: The auto close function would be disabled if both DIP switches are turned to off (factory default setting).

⚠ Important Note: When the auto close function is enabled, the photocell sensor is highly recommended to be installed with the gate opener for safety.

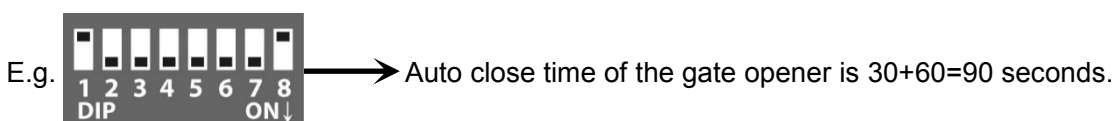

DIP Switch #8: Left/Right open

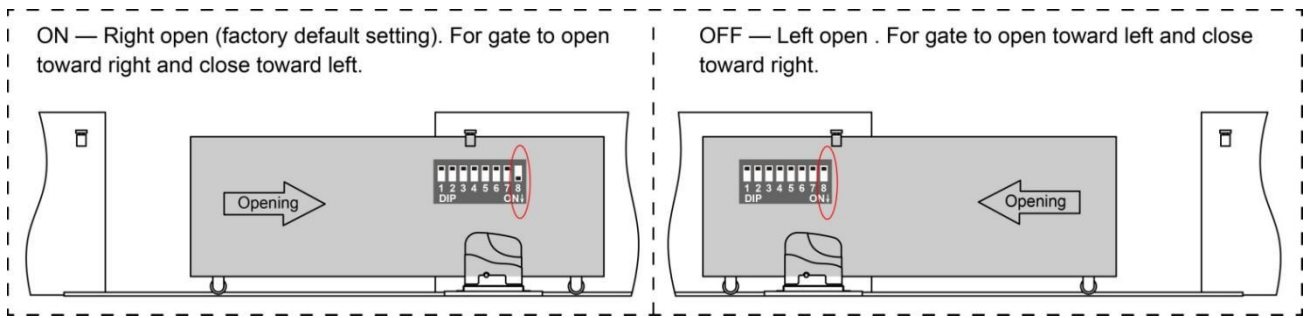

2. Potentiometers

Potentiometer A is used to adjust the close stall force the gate operator. Turn clockwise to increase the stall force, and turn it counter-clockwise to decrease the stall force.

Potentiometer B is used to adjust the open stall force the gate operator. Turn clockwise to increase the stall force, and turn it counter-clockwise to decrease the stall force.

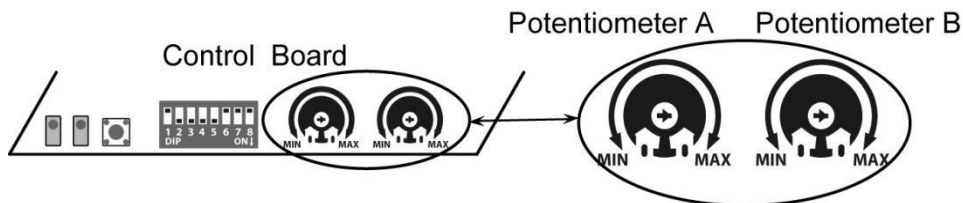

⚠ WARNING: Photocell is highly recommended to be installed with the gate opener as entrapment protection for safety when you set stall force to maximum.

Test the Reversing Sensitivity

For the sake of safety, it is very important to test the reversing sensitivity as soon as the control board set is finished.

The reversing sensitivity adjustment is inverse correlation with stall force adjustment in potentiometer A and B. In other word, the stall force level is higher; the reversing sensitivity level is lower.

Put an immobile object along the gate path, and then operate the gate to strike it during the close cycles. The gate must reverse as soon as object is struck with it. If the gate doesn't reverse, please increase the reversing sensitivity by turning the potentiometer in counter-clockwise direction. (Turning the stall force potentiometer toward to MIN position to increase the reversing sensitivity)

Note 1: If the sensivity setting is too higher, the gate will stop or reverses very easy by itself while there is little obstruction or resistance such as strong wind or heavy snow sometimes.

Note 2: Always check the gate reversing function every each time of control board set or restart after power off.

How to Program or Erase the Remote

- ❖ **The remote MUST be programed to the opener BEFORE OPERATING. Please follow the steps to program the remote.**
- ❖ **Activate the opener only when gate is in full view, free of obstruction and properly adjusted. No one should enter or leave gate area while gate is in motion. DO NOT ALLOW CHILDREN to operate push button or remote. DO NOT ALLOW CHILDREN TO PLAY NEAR THE GATE.**
- ❖ **If you purchase additional remote controls, the gate opener must be programmed to accept the new remote code.**
- ❖ **If you lose one of any remote control, please erase and reprogram all other remote controls to have a new code for safety.**

Program the remote

Press and release the learn button, the **REM LED** light will be on, then press the key in the remote **two times** in 2 seconds, **between the two times HOLD ON FOR A MOMENT**, the **REM LED** light will flash for 4 seconds. Now the remote has been programmed successfully.

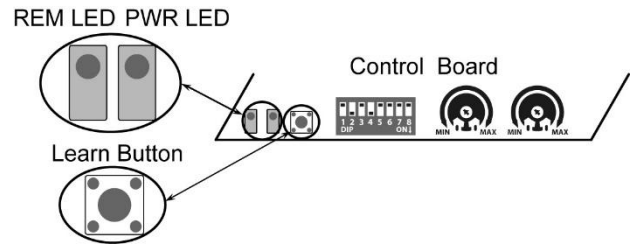

Erase all the remote codes

Press and hold the learn button until the **REM LED** light is off. Now all remote codes have been erased.

- ✦ **NOTE: Max. 8 remotes can be programmed for the opener. An External Receiver (optional) allows up to 250pcs remotes to be programmed for the opener. TOPENS ERM12 Universal External Receiver is available at TOPENS Store.**
- ✦ **TOPENS ERM12 Universal External Receiver is also compatible with other brand swing gate opener, sliding gate opener and garage door opener.**

How to Use the Remote to Operate Your Gate Opener

Each remote has four buttons, from top to bottom are separately A, B, C and D. You may use this remote to operate as many as 4 sets TOPENS swing gate openers or 1 set TOPENS sliding gate opener and 2 sets TOPENS swing gate openers.

1. Use this remote to only operate TOPENS swing gate opener A, B, C and D four buttons share same function once they are programmed with TOPENS swing gate opener. You may choose any button to program it with our swing gate opener. Every press of the button is able to activate the gate opener to work alternately (open-stop-close-stop-open).
2. Use one remote to operate TOPENS swing gate opener & sliding gate opener at the same time

All of TOPENS sliding gate opener have midway mode. Button B is designed to realize midway function (refer to more details in our TOPENS sliding gate opener manual). So it is must program button A with sliding gate opener, while you may program either C button or D button with TOPENS swing gate opener.

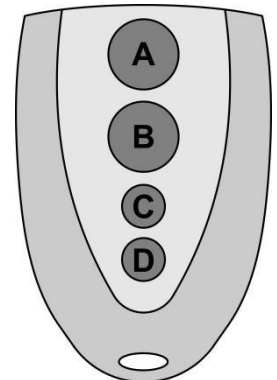

Wireless Keypad Programming

You can follow the below steps to program wireless keypad to the opener. Press the **Learn** button until the **REM LED** is ON, and then releases the button. Then press "OK" button on keypad and **REM LED** will flash for 3 seconds and then be OFF which indicates the keypad has been programmed successfully. You can use the default password "888888" to operate the opener after programming. You can press "PIN" "8 8 8 8 8" and then press "OK" to confirm to operate the opener.

Also you can change the password of the keypad follow the below steps. Press "PIN" and then input the six digits old password and then press "PIN" again, the **REM LED** will be ON. Input the six digits new password and then press the "PIN" to confirm the new setting, **REM LED** will flash for 3 seconds and then be OFF which indicates the password has been changed successfully. You can press "PIN" "6 digits new password" and then press "OK" to confirm to operate the opener.



Wireless Keypad

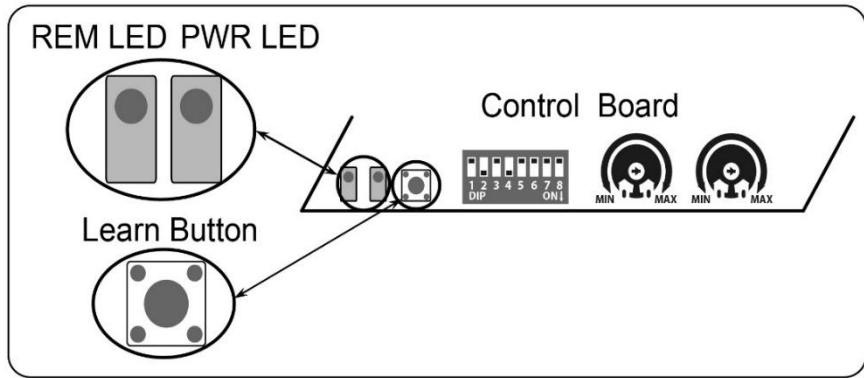

NOTE: Every step for pressing button during program must be finished within 1 second to ensure successful programming.

Troubleshooting



**Need help or have questions? DO NOT RETURN to the store.
Visit www.topens.com to CONTACT US.**

Have a multi-meter to check voltage and continuity. Use caution when checking high voltage terminals.

Symptom	Possible Solution(s)
The opener does not run. Power LED is OFF.	<ol style="list-style-type: none"> 1. Make sure that the power cord is properly plugged into the mains outlet. 2. Check if the output voltage of the transformer is 24VAC. If the voltage measures 0, the transformer may be overheated or damaged. Turn power off and allow board to cool for several minutes then reset. Replace the transformer if the symptom still exists. 3. Check the fuse in the control board. Replace the fuse if it was burnt out. 4. Check the status of the over-discharged LED on the solar controller, the voltage of the batteries is too low to power the gate opener if the LED is ON. Please wait the batteries are charged to full. 5. The solar controller could be faulty if the over-discharged LED is ON when the voltage of the batteries is normal (>24VDC). 6. Check the control board. Replace the control board if necessary.
The opener does not run. Power LED is ON.	<ol style="list-style-type: none"> 1. Check to be sure the beam is not blocked if a photocell is used as a secondary entrapment prevention device. If a photocell is not used, photocell terminal of the control board should be shorted by a jumper wire. 2. Check the motor. Release the clutch then disconnect the wires of the motor from terminal 1 and 2. Connect the wires to 24V battery directly, the motor should run, and then exchange the wires, the motor should run in the opposite direction. If the motor runs in both directions, please check the other parts listed below. 3. Check the limit switch. Use a jumper wire to short terminal 4 with terminal

	<p>3 and 5, and then use a keying device to operate the opener, replace the limit switch if the motor could run in both directions.</p> <p>4. Check the control board. Replace the control board if necessary.</p>
Remote control does not work.	<p>1. The indicator light of remote control is not on. Check the battery in your remote control. Replace the battery if necessary.</p> <p>2. The distance you use the remote is too far away from the opener. Try it again closer.</p> <p>3. Remote control is not suitable for receiver. After making sure the codes are correct, erase remote controls and then re-program the codes in the device.</p> <p>4. Check the control board. Replace the control board if necessary.</p>
The gate starts but it is immediately stop or reverse	<p>1. Check the HALL sensor board in the side of the gear box has been connected to the control board tightly.</p> <p>2. Check that the clutch is adjusted properly and is not slipping.</p> <p>3. The opening force or closing force is adjusted too small. Turn the Potentiometer A&B to increase the force.</p> <p>4. Disconnect the gate from the gate opener and check that the gate slides freely without any binding.</p> <p>5. Check the control board. Replace the control board if necessary.</p>
The gate opens, but stops and will not return.	<p>1. Please note the two limit magnets are different: one is N pole and another is S pole. Please try to exchange the two magnets.</p> <p>2. Please try to exchange the limit switch wires CL (close) and OP (open).</p> <p>3. Maybe the magnet was installed in the wrong position so it inducts both switches. Adjust the magnets to the correct position refer to the manual.</p> <p>4. Check the control board. Replace the control board if necessary.</p>
The gate can open, but fails to close.	<p>1. Photocell is obstructed. Remove obstruction.</p> <p>2. The limit switch is failed. Use a jumper wire to short terminal 4 with terminal 3 and 5, and then use a keying device to operate the opener, replace the limit switch if the motor could run in both directions.</p> <p>3. Check the control board. Replace the control board if necessary.</p>

Maintenance

Every six months check the following items for proper operation of the unit.

- * Lubricate shafts and gears.
- * Keep opener clean at all times.
- * Check and tighten anchors bolts.
- * Check for loose or corroded wire
- * Ensure the opener is well earthed, and correctly terminated.
- * Always check the Stop/Reverse in case of obstruction function when performing any maintenance. If this function can't be made operable, remove this opener from service until the cause of the malfunction is identified and corrected.

DECLARATION OF CONFORMITY



CTS (NINGBO) TESTING SERVICE TECHNOLOGY
OPERATE ACCORDING TO ISO/IEC 17025

EC DECLARATION OF CONFORMITY

EU - ELECTROMAGNETIC COMPATIBILITY DIRECTIVE -

This declares that the following designated product

Sliding gate opener
Model No.: DK1000, DK600, DSR1000S, DSR600S

(Product identification)

Complies with the essential protection requirements of the European Parliament and of the Council Directive 2014/30/EU on the approximation of the laws of the Member States relating to electromagnetic compatibility.

This declaration applies to all specimens manufactured in accordance with the attached manufacturing drawings which form part of this declaration.

Assessment of compliance of the product with the requirements relating to electromagnetic compatibility was based on the following standards:

EN 61000-6-3: 2007+A1:2011+AC:2012
EN 61000-3-2: 2014, EN 61000-3-3: 2013
EN 61000-6-1: 2007

(Identification of regulations / standards)

This declaration is the responsibility of the Applicant / importer

HANGZHOU SANFORD TOOLS CO.,LTD.
8 SHENG DI ROAD , YUHANG TOWN, HANGZHOU 311121 ,CHINA

(Name / Address)



THIS DOC IS ONLY VALID IN CONNECTION WITH TEST REPORT NUMBER: C3190104004-E

MANUFACTURER / IMPORTER

(Date)

(Surname, forename)

(Company stamp)

TEST LABORATORY

This is the result of test, that was carried out from the submitted type-samples of a product in conformity with the specification of the respective standards.

The declaration holder has the right to fix the CE-mark for EMC on the product complying with the inspection sample

15 January 2019

(Date)

(Company stamp)



CTS (Ningbo) Testing Service Technology Co., Ltd.
NB test site: Fl.1 & 8 West, Bldg. B, No. 66, Qingyi Rd., Hi-Tech Zone, Ningbo, Zhejiang, China
GZ test site: A101, No.65, Zhuji Road, Tianhe District, Guangzhou, Guangdong, China

DECLARATION OF CONFORMITY



CENTRE OF TESTING SERVICE
OPERATE ACCORDING TO ISO/IEC 17025

EC DECLARATION OF CONFORMITY
EU - LOW VOLTAGE DIRECTIVE -

This declares that the following designated product:

Sliding gate opener
Model No.: DK1000, DK600, DSR1000S, DSR600S
(Product identification)

Complies with the requirements of the European Community Directive 2014/35/EU.
This declaration is awarded following tests carried out on samples of the product referred to above.
Assumption of compliance of the product with the requirements relating to the
Low Voltage Directive (LVD) was based on the following standards:

EN 60335-1: 2012+A11:2014+A13:2017
EN 60335-2-103:2015
(Identification of regulations / standards)

This declaration is the responsibility of the manufacturer / importer
HANGZHOU SANFORD TOOLS CO.,LTD.
8 SHENG DI ROAD , YUHANG TOWN, HANGZHOU 311121 ,CHINA
(Name / Address)



THIS DOC IS ONLY VALID IN CONNECTION WITH TEST REPORT NUMBER: C3190104002-L

MANUFACTURER / IMPORTER

.....
(Date)

.....
(Surname, forename)
(Company stamp)

TEST LABORATORY

This is the result of test that was carried out from the submitted type-samples of a product in conformity with the specification of the respective standards.
The declaration holder has the right to fix the CE-mark for LVD on the product complying with the inspection sample.

February 19 , 2019
(Date)

(Company stamp)



CTS (Ningbo) Testing Service Technology Co., Ltd.
Fl.1 & 8 West, Bldg. B, No. 66, Qingyi Rd., Hi-Tech Zone, Ningbo, Zhejiang, China



According to Waste of Electrical and Electronic Equipment (WEEE) directive, WEEE should be separately collected and treated. If at any time in future you need to dispose of this product please do NOT dispose of this product with household waste. Please send this product to WEEE collecting points where available.

Feedback & Review

Your comments and suggestions are important to us
as they help us provide the best possible service.

Should you have any need to contact us, the info below will help you get in touch:



TOPENS Website

www.topens.com

Contact Us:

E-mail: support@topens.com

*Kindly include your Product Model, Purchasing Date & Site, Order #,
and your contact information. All your concerns will be replied within 24 hours.*

Tel: +1 (888) 750 9899 (Toll Free USA & Canada)