



Sliding Gate Opener

User's Manual

Model:

CK500

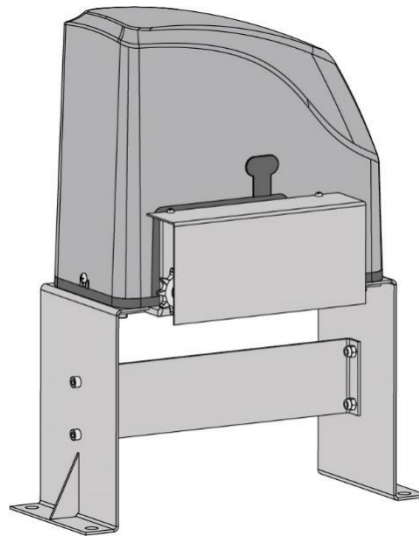

TOPENS Website

www.topens.com

Email: support@topens.com

- ★ Please read and follow all warnings, precautions and instructions before installation and use.
- ★ Periodic checks of the opener are required to ensure safe operation.
- ★ Save this manual.

CONTACT US:

Visit: www.topens.com

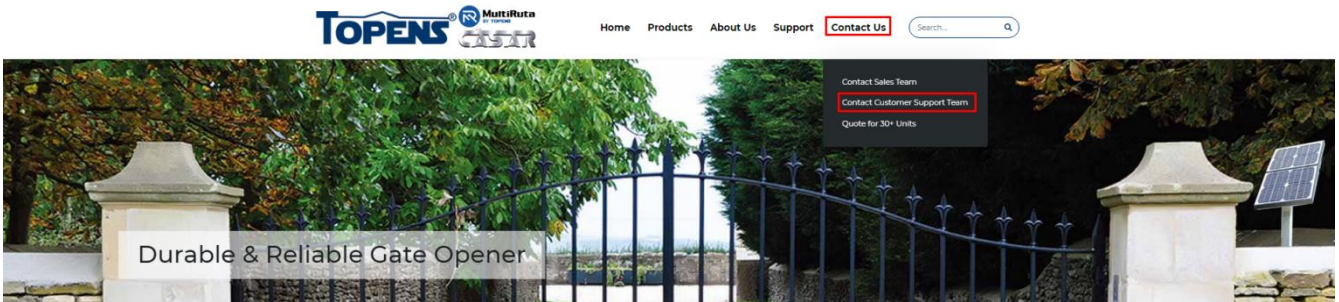

Please record the product model, your email address etc.

in the spaces provided below. Refer to this list when contacting TOPENS for technical service or assistance with your automatic gate opener.

Where did you purchase? (Amazon.com; Amazon.ca: Amazon.co.uk, Amazon.de; Other, Please Specify)

Order#	Product Model	Purchase Date
Full Name	Phone#	Email Address (VERY IMPORTANT)
Street Address, Apartment /Unit, City, State /Province, Zip Code		Country/Region
Approximate Gate Weight (pounds; kg: Other. Please Specify)	Approximate Gate Length (feet; meter; Other. Please Specify)	Did you purchase any accessories? (Please list below)

Issue Details

Email Us: support@topens.com

Call: +1 (888) 750 9899 (Toll Free USA & Canada)

Table of Contents

Check Your Gate before Installation	1
General Safety	1
Preparation for Installation	2
Parts List	4
Accessories Parts (Included in some models, refers to the actual package)	4
Optional Accessories Parts List (Available at TOPENS Store)	5
Replacement Parts	5
Technical Specifications & Features	6
Installation Overview	6
Installation of the Opener	7
Manual Operation	7
Installation of chain and chain brackets	8
Installation of the Magnets	9
Connecting of Power Supply	10
Connecting of the Control Board	10
Setting of the Control Board	12
Test the Reversing Sensitivity	14
How to Program or Erase the Remote	14
How to Use the Remote to Operate Your Gate Opener	15
Wireless Keypad Programming	15
Maintenance	17

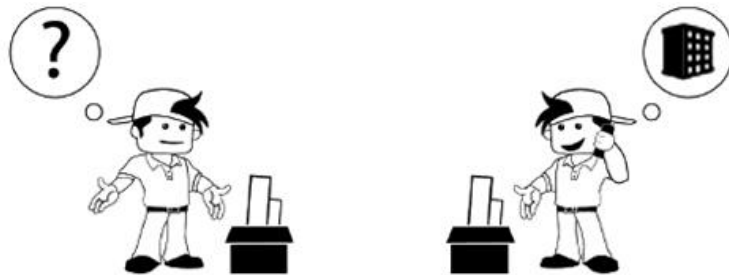

I Ask for TOPENS help by E-mail or phone anytime.

Thank you for purchasing our sliding gate opener. We are sure that the products will be greatly satisfying as soon as you start to use it.

The product is supplied with a user's manual which encloses installation and safety precautions. These should be read carefully before installation and operation as they provide important information about safety, installation, operation and maintenance. This product complies with the recognized technical standards and safety regulations.

Check Your Gate before Installation

CHECK YOUR GATE

Before installation, please make sure that the gate itself can be opened and closed smoothly & freely BY HAND WITHOUT THE GATE OPENER.

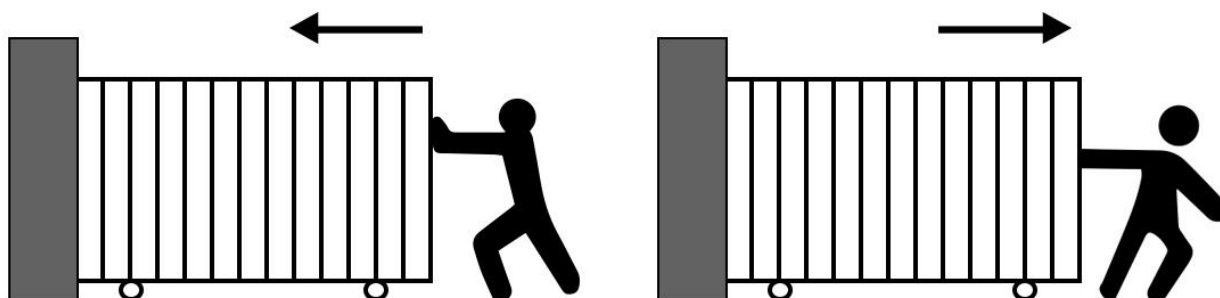

General Safety

⚠️ WARNING! An incorrect installation or improper use of the product can cause damage to persons, animals or properties.

- Scrap packing materials (plastic, cardboard, polystyrene etc.) according to the provisions set out by current standards. Keep nylon or polystyrene bags out of children's reach.
- This product was exclusively designed and manufactured for the use specified in the present documentation. Any other use not specified in this documentation could damage the product and be dangerous.
- The factory declines all responsibility for any consequences resulting from improper use of the product, or use which is different from that expected and specified in the present documentation.
- Do not install the product in explosive atmosphere.
- The factory declines all responsibility for any consequences resulting from failure to observe Good Technical Practice when constructing closing structures (door, gates etc.), as well as from any deformation which might occur during use.
- Disconnect the electrical power supply before carrying out any work on the installation. Also disconnect any buffer batteries, if fitted.
- Fit an omnipolar or magnetothermal switch on the mains power supply, having a contact opening distance equal to or greater than 3,5 mm.
- Make sure a residual current circuit breaker with a 30mA threshold is fitted before the power supply mains.
- Check that earthing is carried out correctly: connect all metal parts for closure (doors, gates etc.) and all system components provided with an earth terminal.
- Fit all the safety devices (photocells, electric edges etc.) which are needed to protect the area from any danger caused by squashing, conveying and shearing.

- Position at least one visible indication device, and fix a Warning sign to the structure.

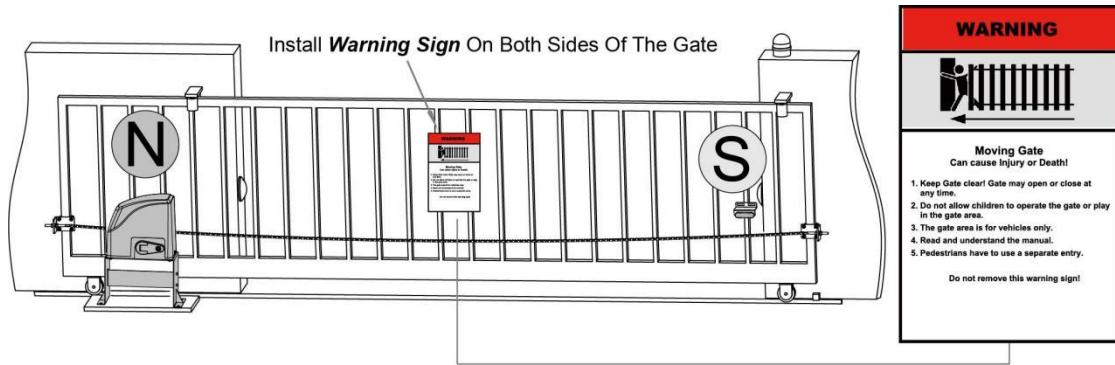

- The factory declines all responsibility with respect to the automation safety and correct operation when other supplier's components are used.
- Only use original parts for any maintenance or repair operation.
- Do not modify the automation components, unless explicitly authorized by the factory.
- Instruct the product user about the control systems provided and the manual opening operation in case of emergency.
- Do not allow persons or children to remain in the automation operation area.
- Keep radio control or other control devices out of children's reach, in order to avoid unintentional automation activation.
- The user must avoid any attempt to carry out work or repair on the automation system, and always request the assistance of qualified personnel.
- Anything which is not expressly provided for in the present instructions is not allowed.
- Before installing the gate opener, check that all moving part as well as the sliding gate is in good mechanical condition, correctly balanced and opens and closes properly.
- Save these instructions for future use.

Preparation for Installation

Before proceeding to your opener installation, check if your gate structure is in accordance with the current standards, especially as follows:

The gate sliding track is linear and horizontal, and the wheels are suitable, the gate should be mounted and moving freely. Check that the structure is sufficiently strong and rigid, Make sure that the gate is plumb and level. The fence posts must be mounted in concrete. The gate does not bind or drag on the ground.

- The opening and closing gate stops are positioned.



WARNING: Remember that control devices are intended to facilitate gate operation, but can not solve problems due to any defects or deficiency resulting from failure to carry out correct installation or maintenance. Take the product out of its packing and inspect it for damage. Should it be damaged, contact your dealer. Remember to dispose of its components (cardboard, polystyrene, nylon, etc.) according to the current prescriptions.

Refer to the following Figures for gate installation.

Using the post or wall as a stop, either directly or indirectly, is not recommended so as to protect the post or wall against damaging shock from the sliding gate.

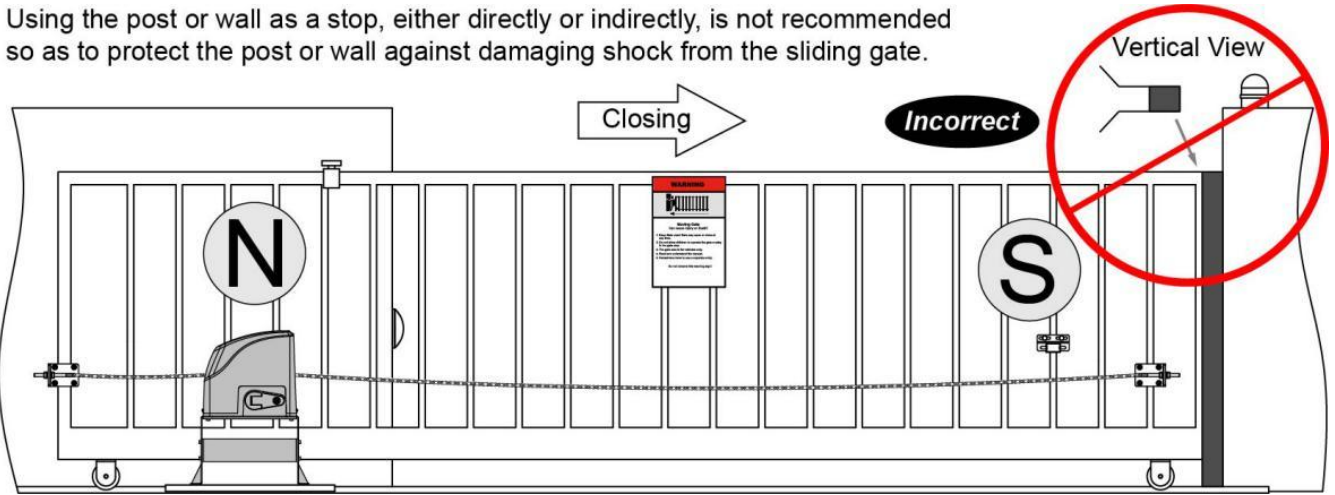

In sake of safety, a positive stop must be mounted on the two end of ground track.

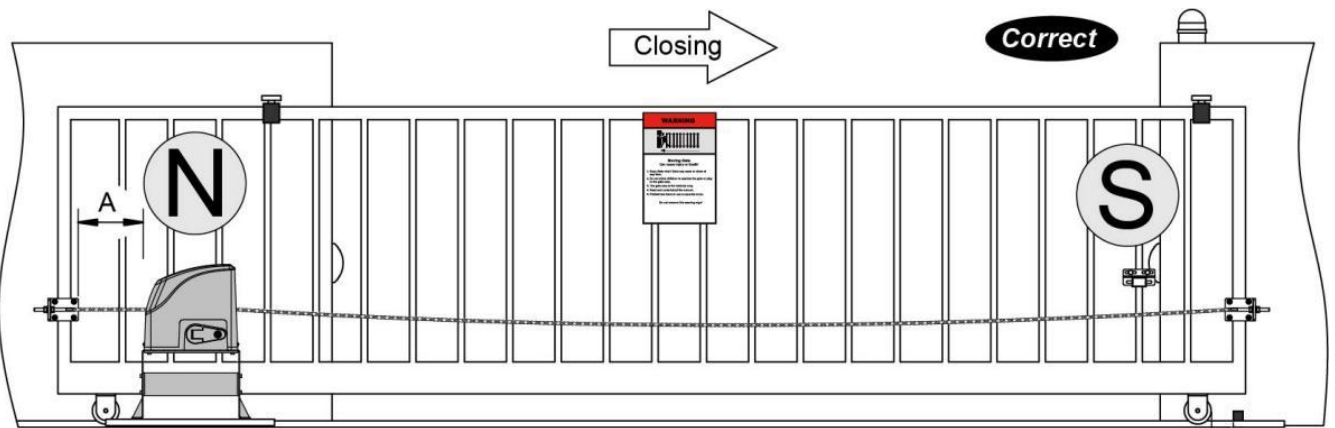

Positive Stop in fully closed position

⚠ Keep the 3" distance at least between operator and chain bracket if the roller hit Positive stop in an accident.

$A-B \geq 3"$

B

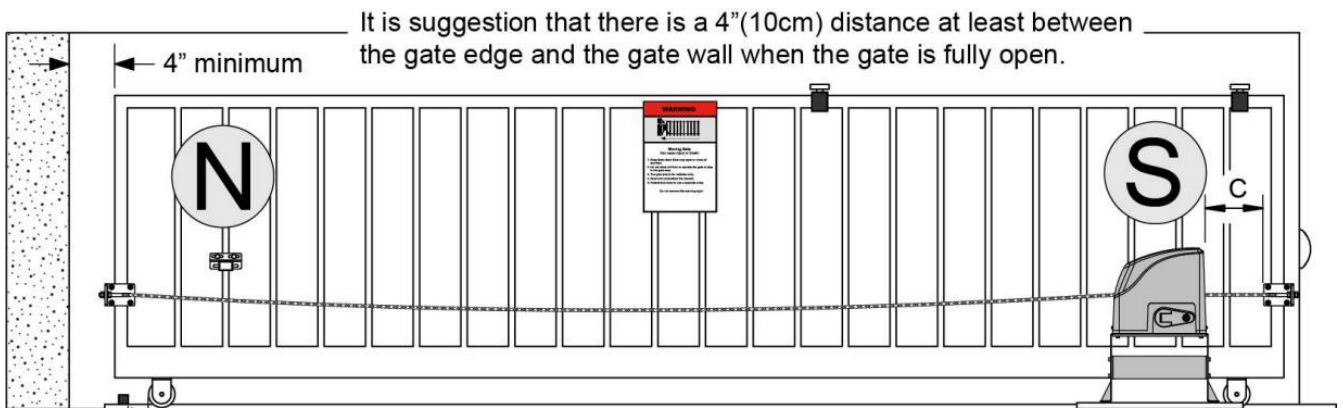











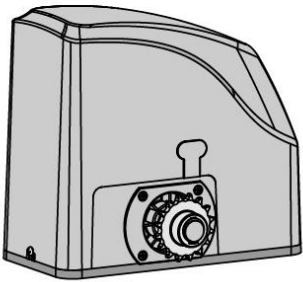
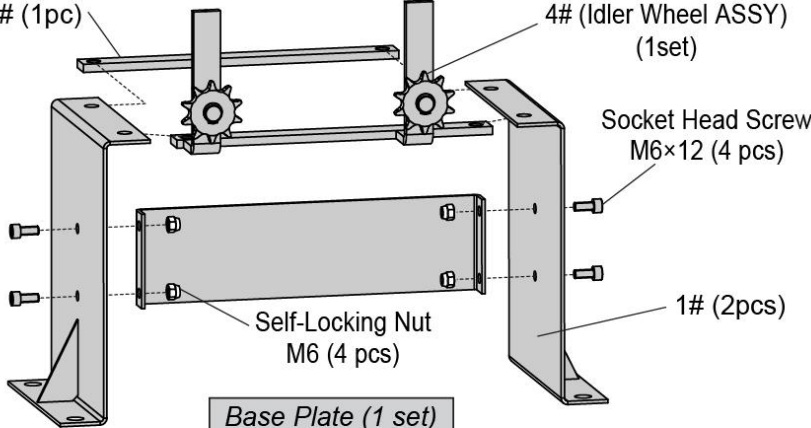



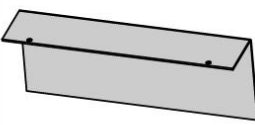







It is suggestion that there is a 4"(10cm) distance at least between the gate edge and the gate wall when the gate is fully open.

⚠ Keep the 3" distance at least between operator and chain bracket if the roller hit Positive stop in an accident.



$C-D \geq 3"$

Opening

Parts List

 <p>Gate Opener (1 pc)</p>		 <p>3# (1pc)</p> <p>4# (Idler Wheel ASSY) (1set)</p> <p>Socket Head Screw M6×12 (4 pcs)</p> <p>Self-Locking Nut M6 (4 pcs)</p> <p>1# (2pcs)</p> <p>Base Plate (1 set)</p>		
 <p>Remote Control (2 pcs)</p>	 <p>Magnet Assembly (N pole & S pole)</p>	 <p>Chain (20ft)</p>	 <p>Wheel Cover (1pc)</p>	 <p>WARNING</p> <p>Moving Gate Can cause Injury or Death!</p> <ol style="list-style-type: none"> 1. Keep Gate clear! Gate may open or close at any time. 2. Do not allow children to operate the gate or play in the gate area. 3. The gate area is for vehicles only. 4. Read and understand the manual. 5. Professionals have to use a separate entry. <p>Do not remove this warning sign!</p>
 <p>Release Key (2 pcs)</p>	 <p>Magnet bracket(2 pcs)</p>	 <p>Square "U" Bolt (4 pcs)</p>	 <p>Round "U" Bolt (4 pcs)</p>	
 <p>"L" Bracket (2 pcs)</p>	 <p>Φ10 Washer (8 pcs)</p>	 <p>Φ8 Washer (20 pcs)</p>	 <p>M10×30 Bolt (4pcs)</p>	
 <p>Expansion Bolt (4 pcs)</p>	 <p>Φ10 Lock Washer (8 pcs)</p>	 <p>Φ8 Lock Washer (20 pcs)</p>	 <p>Master Link (3pcs)</p>	 <p>Pan Head Screw M4×8 (2pcs)</p>
 <p>Chain Bolt (2 pcs)</p>	 <p>M10 Nut (4 pcs)</p>	 <p>M8 Nut (20 pcs)</p>	 <p>M8×70 Bolt (4pcs)</p>	

Accessories Parts (Included in some models, refers to the actual package)

 <p>JD110VY / JD230VY AC Warning Light</p>	 <p>TC102 Photo Eye Beam Sensor</p>
---	--

Optional Accessories Parts List (Available at TOPENS Store)

 <p>M12 Remote Control</p>	 <p>ERM12 External Receiver</p>	 <p>TC186-R WiFi Smartphone Remote Control with Camera</p>	 <p>TC188 Universal Wireless and Wired Keypad</p>
 <p>TKP3 Wireless Keypad</p>	 <p>TC175P Wired Keypad</p>	 <p>HLR01 HomeLink Remote Control Kit</p>	 <p>TC173 Wireless Push Button</p>
 <p>TC147 Wall Push Button</p>	 <p>TC148 Waterproof Wall Push Button</p>	 <p>TRF3 Reflection Photocell Sensor</p>	 <p>TC102 Photo Eye Beam Sensor</p>
 <p>JD110VY / JD230VY AC Warning Light</p>	 <p>LT08B 20 Feet Roller Chain</p>		

Replacement Parts

 <p>ACPYMJ7A Control Board (120V)</p>	 <p>ACPYMJ8A Control Board (230V)</p>	 <p>PYMJ-CKG Limit Switch</p>
--	--	---

WARNING: Changes or modifications not expressly specified by this user manual, TOPENS could void the warranty of this equipment.

Technical Specifications & Features

Specifications	
	CK500
Power input:	110~120V/60Hz or 220~240V/50Hz
Motor voltage:	120VAC or 230VAC
Rated power:	300W
Gate moving speed:	21 cm/s (8.3 in/s)
Max gate weight:	600kg (1300lbs)
Environmental conditions:	-20°C ~ +50°C (0°F to 120°F)
Protection class:	IP44

Features:

- Midway mode.
- Quick selection for the gate open/close direction
- Reliable rolling code technology for remote control
- Emergency release key in case of power failure
- Stop in case of obstruction during gate opening
- Reverse in case of obstruction during gate closing
- Built in adjustable auto-close (1-99 seconds)
- Built in max. Motor Running Time (MRT) for multiple safety protection (90 seconds)
- Reliable electromagnetism limit for easy adjustment
- Can be equipped with a wide range accessories
- Easy to install, and minimum maintenance requirement
- Get the desired chain tension by adjusting the chain bolts

Installation Overview

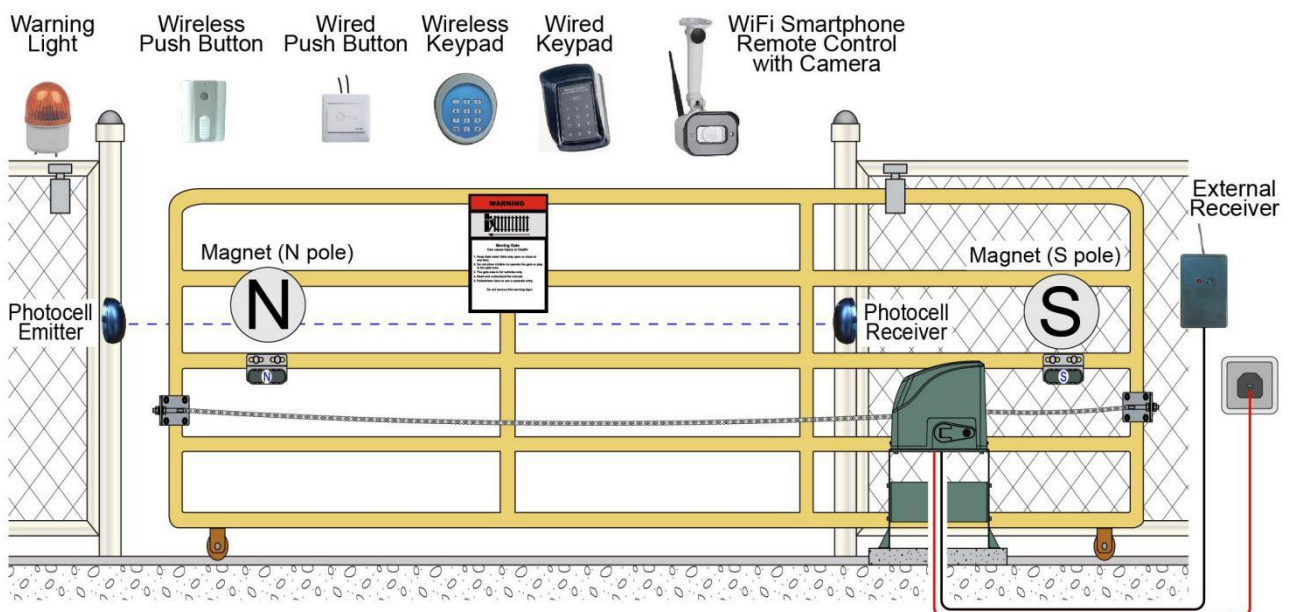

Installation of the Opener

Caution:

*Be sure that the opener is installed in a level and paralleled position. Improper installation could result in property damage, severe injury, and/or death.

* Before starting installation, ensure that there is no point of friction during the entire movement of the gate and there is no danger of derailment.

* Ensure that the safety side rollers are present.

Necessary Tools: The following tools may be necessary to install the Gate opener. You will need screwdrivers, an electric drill, wire cutters and a wire stripper, a socket set, and possibly access to a welder.

When install the opener, you should build a concrete pad to support the base plate of opener in order to maintain proper stability.

The installation proceeds are as follows:

1.Assemble the Base Plate and fix the Opener to the Base Plate.

2.Dig a hole for a concrete pad which should be approximately 60 x 32 x 35cm (24" x 13" x 14"). It may protrude 10 cm (4") above ground and 25 cm (10") in depth underground. Increase the pad height if necessary to protect the system from flooding, heavy snow etc.

3. Prepare one or more conduits for the electrical cables before pour concrete. Remember that cable conduits have to pass through the hole on the base.

4. Pour concrete and before it starts to harden, check that it is parallel to the gate leaf and perfectly level.

5. Mark the position of four expansion anchors according to the position of mounting hole on the base plate. Double check your marking, move the base plate and drill the 4 holes using a 14mm (9/16") masonry bit. Put the 4 expansion anchors (provided) into the holes and firmly tighten.

6. Mount the base plate to the concrete Pad and firmly tighten, enabling the opener is firmly secured on the concrete pad during the whole gate travel.

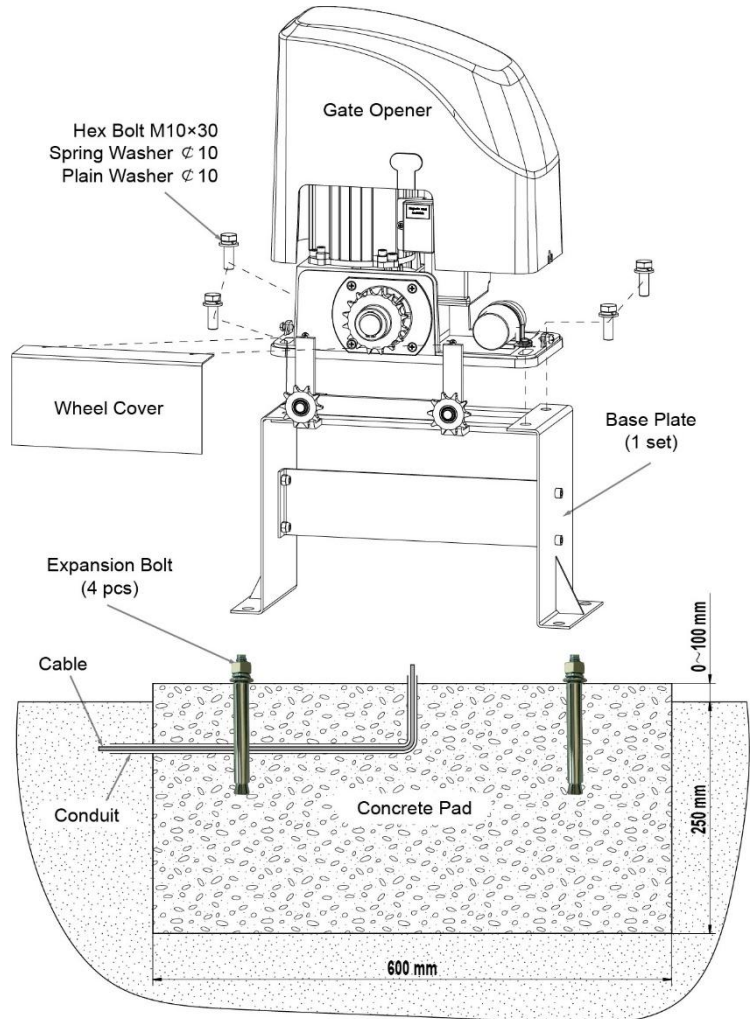

Manual Operation

You can open the gate by manual when power failure. And the opener should be put in the manual (emergency release) position before fitting the rack, installing the opener and limit switch. The process is as follows:

Insert the Release Key and turn it in clockwise 90°, then pull the release handle in clockwise 90° to disengage the clutch between the gear shaft and motor. Now the opener is in the



manual operation.

Installation of chain and chain brackets

1. Chain Brackets

1). Please refer to below chain brackets figure, which shows “U” bolt, “L” bracket and chain bolt. Use the “U” bolts (square or round) to attach the chain brackets to gate frame.

2). If Both the square bolts and round bolts are not fit for the gate frame, use the appropriate bolts to attach the chain brackets to gate frame.

2. How to install the chain

1). Place the chain around the top of the idler wheels and under the drive sprocket in chain box.

2). Connect a chain bolt to one end of chain from chain box by using master link. Then insert the chain bolt to the L bracket and fix them each other by washers and nuts temporarily. (Nuts will be further adjusted for a proper chain tension later)

3). Connect second chain bolt with another end of chain from chain box, then attach bolt to the L bracket on opposite end of gate using the washers and nuts.

4). Make sure that the chain is line up exactly with the position where the chain on the chain idler wheel.

5). Remove the unwanted length of chain. Set appropriated chain tension by adjusting two chain bolts of the both end.

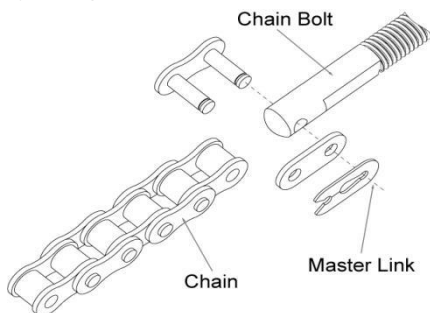
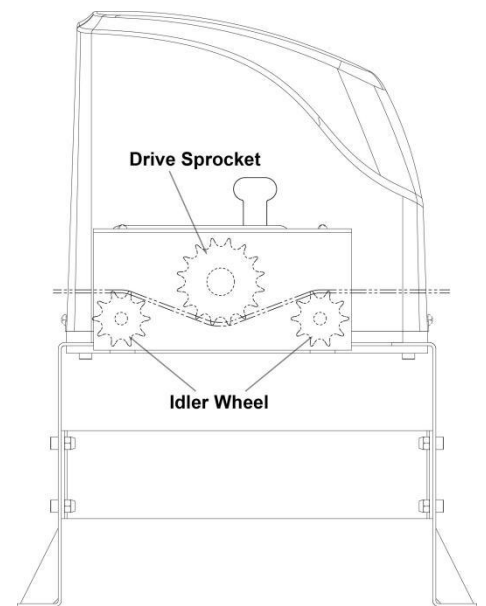
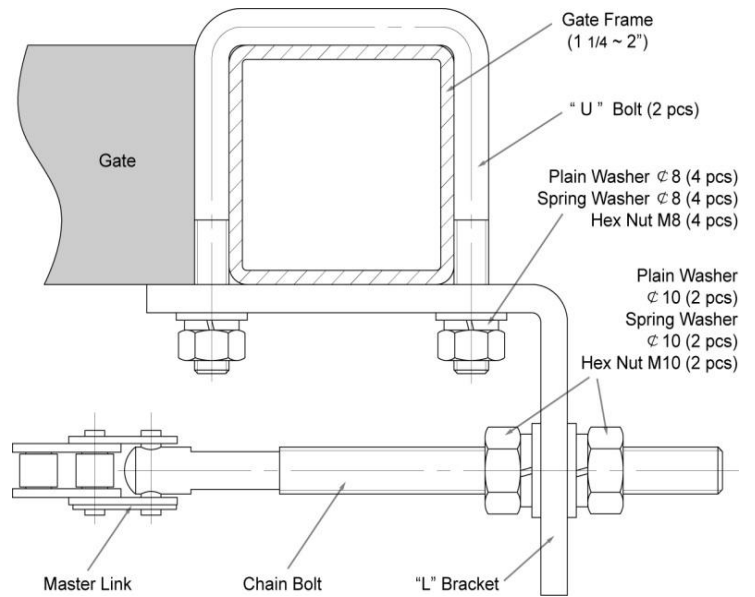

6). The chain brackets must be mounted to the same height as the chain on the idler wheels.

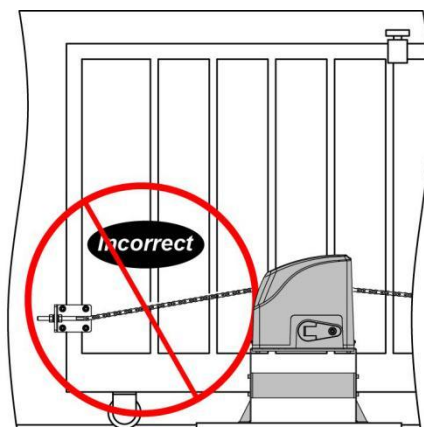
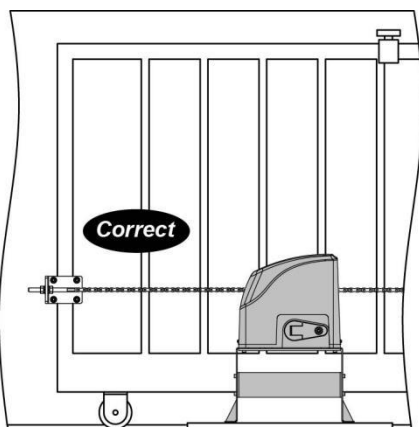

7). Make sure there is 1" distance at least between the wheel cover and the gate after you position the base plate.

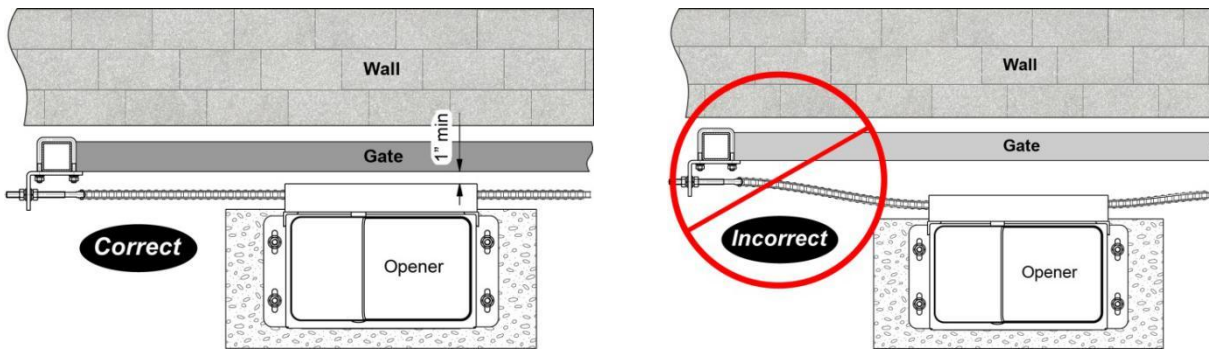

Installation of the Magnets

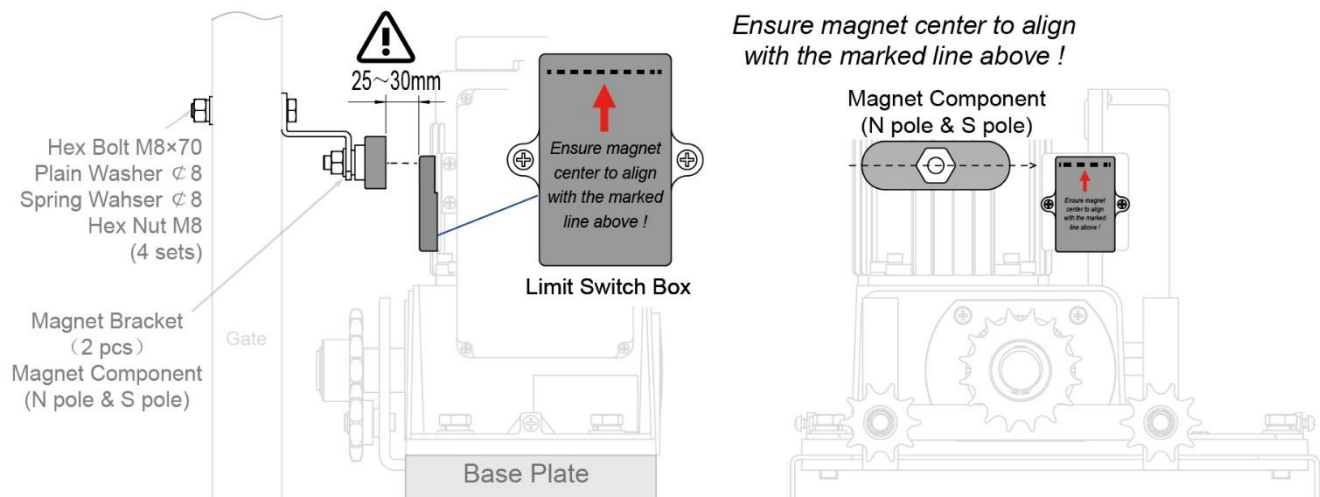

Before install limit switch, make sure the gate opener is put in manual operation. (the clutch connected with gear shaft is disengaged) and the mains power supply is disconnected. Position the two Magnet Components approximately on the gate and move the gate by hand to fix them in place.

Fit magnets bracket

Push the gate fully closed by hand. Locate and install the magnet bracket so that the opener will stop at the desired close position when the close limit switch approaches it.

Push the gate fully open by hand. Locate and install the magnet bracket so that the opener will stop at the desired open position when the open limit switch approaches it.

The magnet component with N pole must be installed at left side and the magnet component with S pole must be installed at right side from the view inside of property.

Ensure magnet center to align with the marked line above !

The magnets should be **25~30mm** away from the **Limit Switch Box**. If it is too near or too far, the switches will fail to work. Adjust the position of the magnets until the positions of the opening and closing meet the requirement.

Warning: Improper magnets installation may cause the gate crash into end barrier, which is very dangerous !

Connecting of Power Supply

⚠ WARNING: NEVER connect the gate opener to the power outlet before all the installations have been done.

The power supply cord should be at least $3 \times 0.75 \text{mm}^2$ (3C×18AWG). Connect the live wire and neutral wire to the “L” (2) and “N” (1) terminal of the control board respectively; and connect the earth wire to “PE”.

NOTE: The power supply cord is not included in the package.



Connecting of the Control Board

1. Motor

The **BLACK** wire of the motor should be connected into the “3” terminal.

The **YELLOW** wire of the motor should be connected into the “4” terminal.

The **RED** wire of the motor should be connected into the “5” terminal.

2. Limit Switches

The **YELLOW** wire of the limit switches should be connected into the “8” terminal.

The **BLACK** wire of the limit switches should be connected into the “9” terminal.

The **RED** wire of the limit switches should be connected into the “10” terminal.

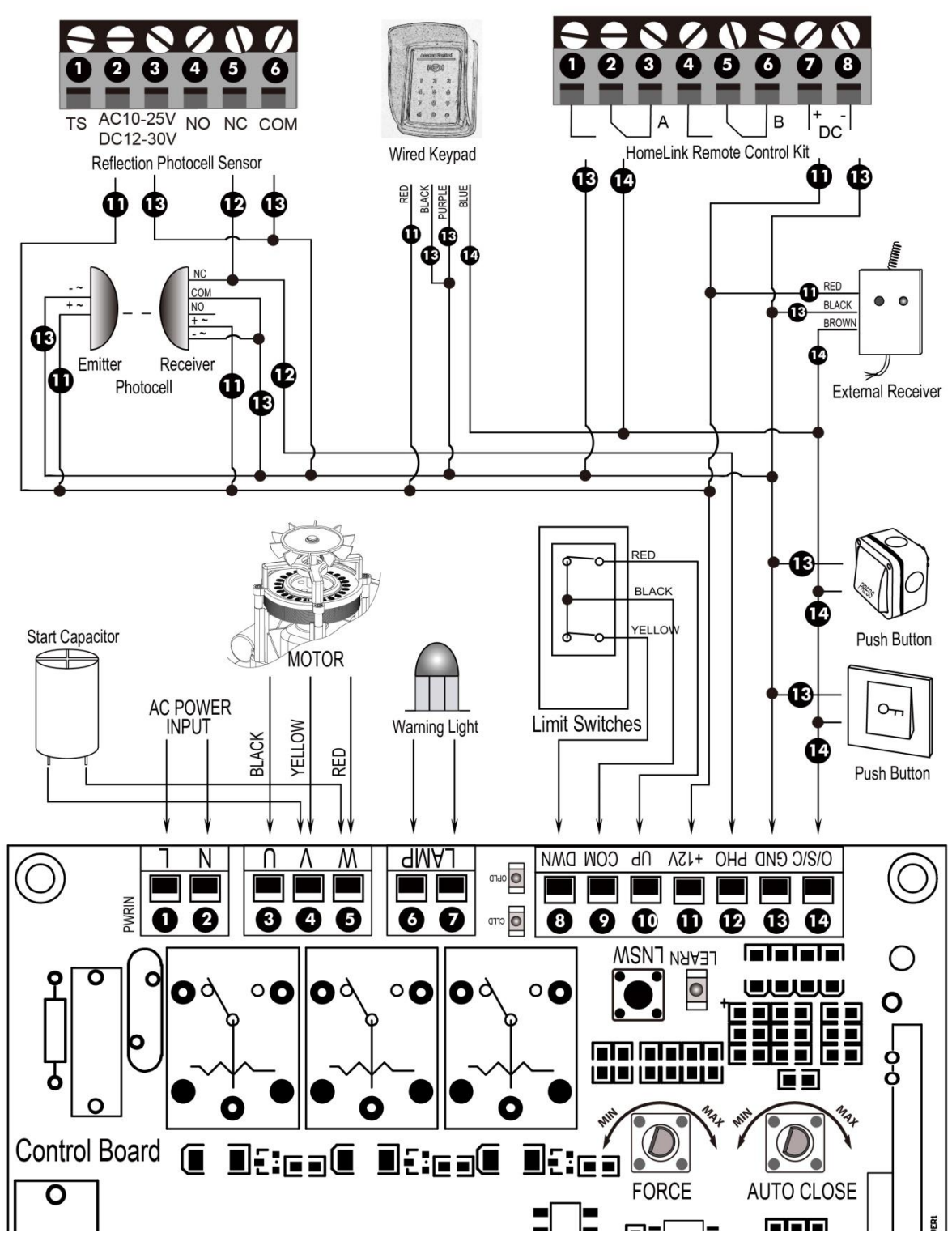

3. Warning Light (Included in some models, refers to the actual package)

One wire of the warning light should be connected into the “6” terminal, another should be connected into the “7” terminal.

4. Start Capacitor

The two wires of the start capacitor should be connected into the “4” terminal and “5” terminal.

5. Photocell Beam System (PBS) (Included in some models, refers to the actual package)

Use a 2-core cable to connect the “+ ~” terminal of the photocell’s emitter to the “11” terminal, the “- ~” terminal to the “13” terminal. Also the “+ ~” and “- ~” terminals of the photocell’s receiver should be connected to the “11” and “13” terminals in parallel.

Use another 2-core cable to connect the “COM” terminal of the receiver to the “13” terminal, the “NC”

terminal to the “12” terminal.

6. Reflection Photocell Sensor (optional)

The “**AC10-25V/DC12-30V**” terminals of the reflection photocell sensor should be connected to the “11” and “13” terminals, no matter the polarity.

The “**NC**” terminal should be connected to the “12” terminal.

The “**COM**” terminal should be connected to the “13” terminal.





TIPS

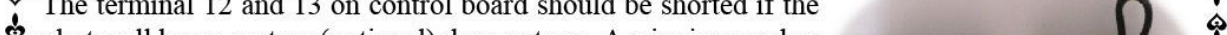

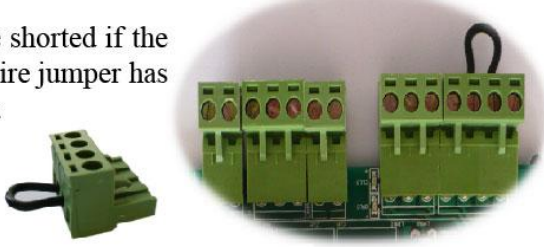
The terminal 12 and 13 on control board should be shorted if the photocell beam system (optional) does not use. A wire jumper has been used for short to terminal 12 and 13 in factory.

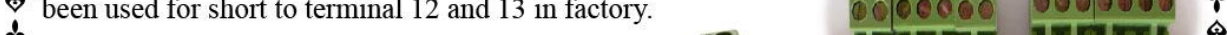

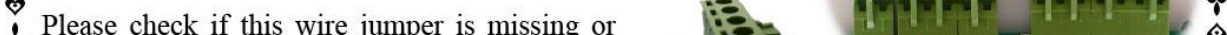
Please check if this wire jumper is missing or keep the photocell in alignment when the gate can open but fails to close.



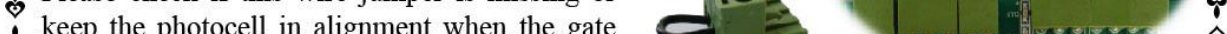













7. Wired Keypad (12VDC) (Optional)

The **RED** wire of the wired keypad should be connected into the “11” terminal.

The **BLACK** wire of the wired keypad should be connected into the “13” terminal.

The **PURPLE** wire of the wired keypad should be connected into the “13” terminal.

The **BLUE** wire of the wired keypad should be connected into the “14” terminal.

8. Push Button (Optional)

The push button should be wired to the “13” and “14” terminals. The gate operator works alternately by pushing the button (open-stop-close-stop-open).

9. External receiver (optional)

The **RED** wire of the external receiver should be connected into the “#11” terminal.

The **BLACK** wire of the external receiver should be connected into the “#13” terminal.

The **BROWN** wire of the external receiver should be connected into the “#14” terminal.

10. HomeLink Remote Control Kit (optional)

The “1” terminal should be connected to the “13” terminal.

The “2” terminal should be connected to the “14” terminal.

The “DC+” terminal should be connected to the “11” terminal.

The “DC-” terminal should be connected to the “13” terminal.

Setting of the Control Board

⚠ WARNING: Ensure the gate opener is Power Off when you make any adjustment of the gate opener. Keep away from the gate during you set the gate opener system in case of the unexpected gate moving. Carefully adjust the DIP switches to avoid the risk of machine damage and injury or death. Always ask the help of professional technician /electrician if you have any question.

1. DIP Switches

The DIP switches are used to set the running time of the motor in pedestrian mode, enable/disable auto close function of the gate operator and fast change the open/close direction which is determined by the position of

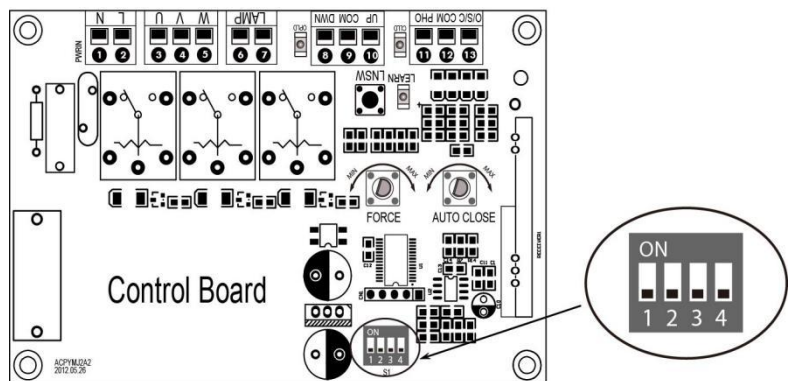

the gate operator installed.

DIP Switch #1-#2: Running time of the motor in Midway Mode

DIP Switch #1: ON – 2 Seconds OFF – 0

DIP Switch #2: ON – 4 Seconds OFF – 0

NOTE: The midway mode function would be disabled if both DIP switches are turned off. Factory default setting is disabled. The midway mode could be activated by pressing button B of the remote control when the gate is in the full closed position.

E.g.  Running time of the operator in midway mode is 2 seconds.

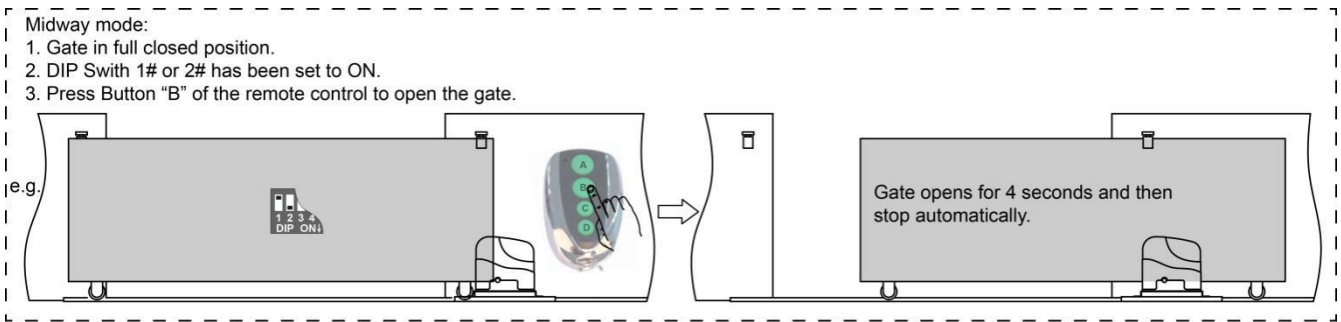

DIP Switch #3: Auto close function enabled/disabled

DIP Switch #3: ON – auto close function enabled

OFF –auto close function disabled

E.g.  Auto close function of the opener has been enabled. Factory default setting is disabled.

⚠ Important Note: When the auto close function is enabled, the photocell sensor is highly recommended to be installed with the gate opener for safety.

DIP Switch #4: Left/Right open

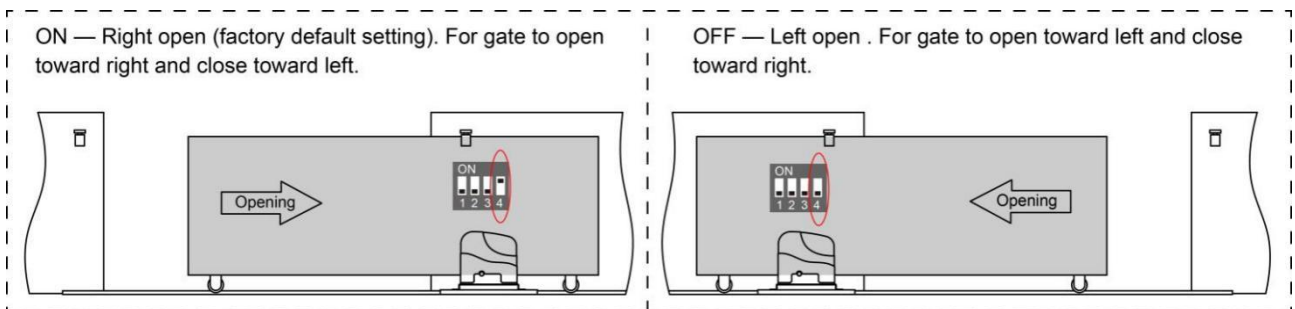

2. Potentiometers

Potentiometer A and B are used to adjust the stall force and auto close time of the gate operator separately. Turn **potentiometer A** clockwise to increase the stall force, and turn it counter-clockwise to decrease the stall force.

⚠ WARNING: Photocell is highly recommended to be installed with the gate opener as entrapment protection for safety when you set stall force to maximum.

Turn **potentiometer B** clockwise to increase the auto close time, and turn it counter-clockwise to decrease the auto close time, the auto close time could be adjusted gradually from 1 to 99 seconds.

250pcs remotes to be programmed for the opener. TOPENS ERM12 Universal External Receiver is available at TOPENS Store.

- ✧ TOPENS ERM12 Universal External Receiver is also compatible with other brand swing gate opener, sliding gate opener and garage door opener.

How to Use the Remote to Operate Your Gate Opener

Each remote has four buttons, from top to bottom are separately A, B, C and D. You may use this remote to operate as many as 4 sets TOPENS swing gate openers or 1 set TOPENS sliding gate opener and 2 sets TOPENS swing gate openers.

1. Use this remote to only operate TOPENS swing gate opener A, B, C and D four buttons share same function once they are programmed with TOPENS swing gate opener. You may choose any button to program it with our swing gate opener. Every press of the button is able to active the gate opener to work alternately (open-stop-close-stop-open).
2. Use one remote to operate TOPENS swing gate opener & sliding gate opener at the same time

All of TOPENS sliding gate opener have midway mode. Button B is designed to realize midway function (refer to more details in our TOPENS sliding gate opener manual). So it is must program button A with sliding gate opener, while you may program either C button or D button with TOPENS swing gate opener.

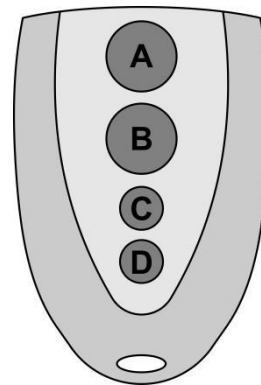

Wireless Keypad Programming

You can follow the below steps to program wireless keypad to the opener. Press the **LNSW** button until the **LEARN** LED is ON, and then releases the button. Then press "OK" button on keypad and **LEARN** LED will flash for 3 seconds and then be OFF which indicates the keypad has been programmed successfully. You can use the default password "888888" to operate the opener after programming. You can press "PIN" "8 8 8 8 8 8" and then press "OK" to confirm to operate the opener.

Also you can change the password of the keypad follow the below steps. Press "PIN" and then input the six digits old password and then press "PIN" again, the **LEARN** LED will be ON. Input the six digits new password and then press the "PIN" to confirm the new setting, **LEARN** LED will flash for 3 seconds and then be OFF which indicates the password has been changed successfully. You can press "PIN" "6 digits new password" and then press "OK" to confirm to operate the opener.

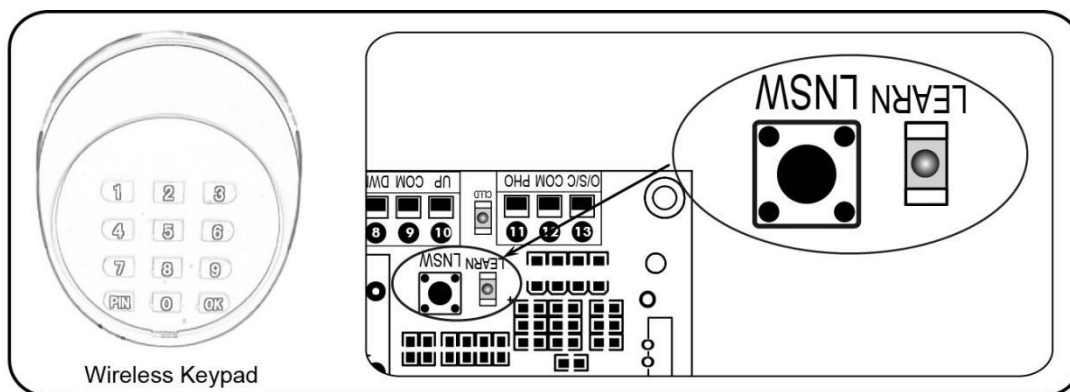

NOTE: Every step for pressing button during program must be finished within 1 second to ensure successful programming.

Troubleshooting



Have a multimeter to check voltage and continuity. Use caution when checking high voltage terminals.

Symptom	Possible Solution(s)
The opener does not run.	<ol style="list-style-type: none"> 1. Check the input voltage of the control board. It should be local AC electricity. 2. Check the fuse in the control board. Replace the fuse if it was burnt out. 3. Ensure the remote control has been programmed to the control board before operating. 4. The thermal protector is working because the high temperature after long working time. Please wait for 20 minutes to let the motor become cold. 5. Check the installing position of the limit magnets. The opener would not run if both of the limit switches are activated by one magnet. 6. Check the limit switch. Remove the wire connection of the limit switch which is connected to the 8#, 9#, and 10# terminals of the control board and then use a jumper wire to short the 3 terminals together to try it again. Replace the limit switch if the motor could run in both directions. 7. Check the control board. Replace the control board as necessary.
Remote control does not work.	<ol style="list-style-type: none"> 1. The indicator light of remote control is not on. Check the battery in your remote control. Replace the battery as necessary. 2. The distance you use the remote is too far away from the opener. Try it again closer. 3. Remote control is not suitable for receiver. After making sure the codes are correct, erase remote controls and then re-program the codes in the device. 4. Check the control board. Replace the control board as necessary.
The gate starts but it is immediately stop or reverse	<ol style="list-style-type: none"> 1. Check the wire connection of hall sensor board with the main control board. 2. The opening force or closing force is adjusted too small. Turn the Potentiometer A to increase the force. 3. Disconnect the gate from the gate opener and check that the gate slides freely without any binding. 4. Check the control board. Replace the control board as necessary.
The gate opens, but stops and will not return.	<ol style="list-style-type: none"> 1. Check the installing position of the magnets. The opener would not run if both of the limit switches are activated by one magnet. 2. Check the limit switch. Remove the wire connection of the limit switch which is connected to the 8#, 9#, and 10# terminals of the control board and then use a jumper wire to short the 3 terminals together to try it again.

	<p>Replace the limit switch if the motor could run in both directions.</p> <p>3. Check the control board. Replace the control board as necessary.</p>
<p>The gate can open, but fails to close.</p>	<p>1. Photocell is obstructed. Remove obstruction.</p> <p>2. Check the limit switch. Remove the wire connection of the limit switch which is connected to the 8#, 9#, and 10# terminals of the control board and then use a jumper wire to short the 3 terminals together to try it again. Replace the limit switch if the motor could run in both directions.</p> <p>3. Check the control board. Replace the control board if necessary.</p>
<p>The gate will open automatically instead of close after the auto close time</p>	<p>Ensure the DIP 4# has been set correctly according to the installation for "Left Open" or "Right Open"</p>
<p>The motor runs but the gate doesn't move.</p>	<p>Ensure the clutch for emergency release is adjusted properly and is not slipping.</p>

Maintenance

Every six months check the following items for proper operation of the unit.

- * Lubricate shafts and sprockets.
- * Keep operator clean at all times.
- * Check and tighten anchors bolts.
- * Check for loose or corroded wire
- * Ensure the operator is well earthed, and correctly terminated.
- * Always check the Stop/Reverse in case of obstruction function when performing any maintenance. If this function can't be made operable, remove this operator from service until the cause of the malfunction is identified and corrected.

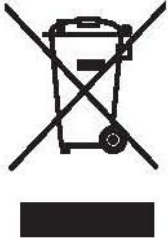

According to Waste of Electrical and Electronic Equipment (WEEE) directive, WEEE should be separately collected and treated. If at any time in future you need to dispose of this product please do NOT dispose of this product with household waste. Please send this product to WEEE collecting points where available.

Feedback & Review

Your comments and suggestions are important to us
as they help us provide the best possible service.

Should you have any need to contact us, the info below will help you get in touch:



TOPENS Website

www.topens.com

Contact Us:

E-mail: support@topens.com

*Kindly include your Product Model, Purchasing Date & Site, Order #,
and your contact information. All your concerns will be replied within 24 hours.*

Tel: +1 (888) 750 9899 (Toll Free USA & Canada)