



Dual Swing Gate Opener

User's Manual

Model:

AT602

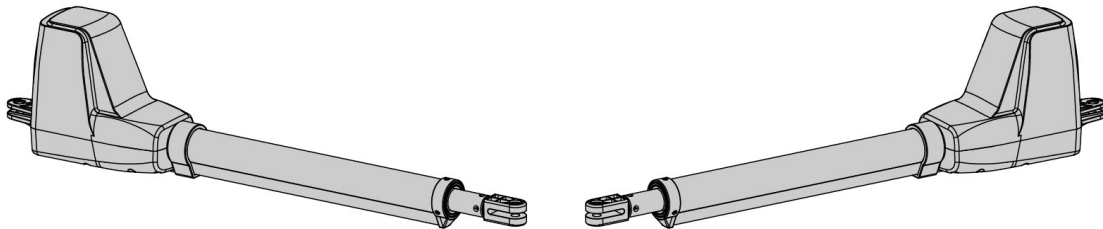

TOPENS Website

www.topens.com

Email: support@topens.com

- ★ Please read and follow all warnings, precautions and instructions before installation and use.
- ★ Never connect the solar panel to the control board directly to charge the battery.
- ★ Periodic checks of the opener are required to ensure safe operation.
- ★ Save this manual.



CONTACT US:

Visit: www.topens.com

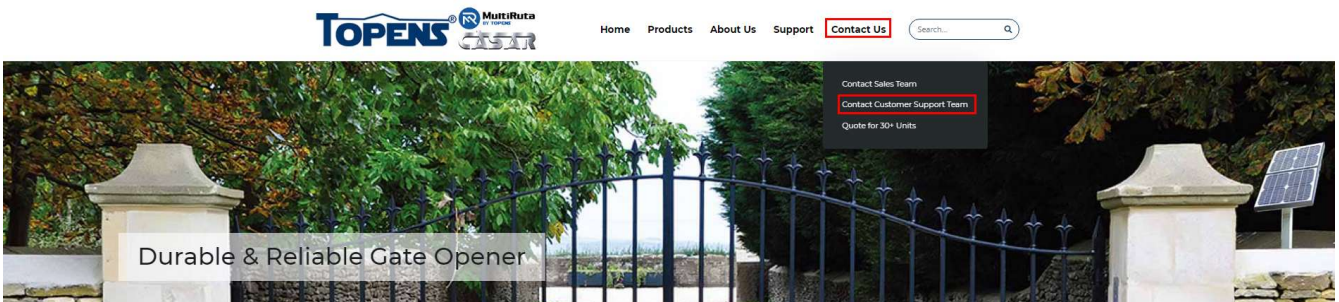

Please record the product model, your email address etc.

in the spaces provided below. Refer to this list when contacting TOPENS for technical service or assistance with your automatic gate opener.

Where did you purchase? (Amazon.com; Amazon.ca; Amazon.co.uk, Amazon.de; Other, Please Specify)

Order#	Product Model	Purchase Date
Full Name	Phone#	Email Address (VERY IMPORTANT)
Street Address, Apartment /Unit, City, State /Province, Zip Code		Country/Region
Approximate Gate Weight Per Leaf (pounds; kg: Other. Please Specify)	Approximate Gate Length Per Leaf (feet meter; Other. Please Specify)	Did you purchase any accessories? (Please list below)
Issue Details		

Email Us: support@topens.com

Call: +1 (888) 750 9899 (Toll Free USA & Canada)

Table of Contents

Safety Installation Information.....	1
AT602 Parts List.....	3
Accessories Parts (Included in some models, refers to the actual package).....	3
Optional Accessories Parts List (Available at TOPENS Store).....	4
Replacement Parts	4
Tools Needed:	4
Technical Specifications & Features	5
Installation Overview	6
Preparation for Installation	7
Install the Opener on the Gate – <i>for Pull to Open</i>	7
Install the Opener on the Gate – <i>for Push to Open</i>	10
Mounting the Control Box.....	13
Connection of Power Supply.....	14
Connecting of the Control Board.....	14
How to Program or Erase the Remote.....	16
How to Use the Remote to Operate Your Gate Opener	17
Wireless Keypad Programming.....	17
Setting of the Control Board.....	18
Indicate Illustration on the Digital Display When Gate Opener is Running	21
Adjusting the Limit Switch	21
How to Operate	22
Maintenance.....	22
Trouble Shooting.....	25
Quick-Setting Guide	26

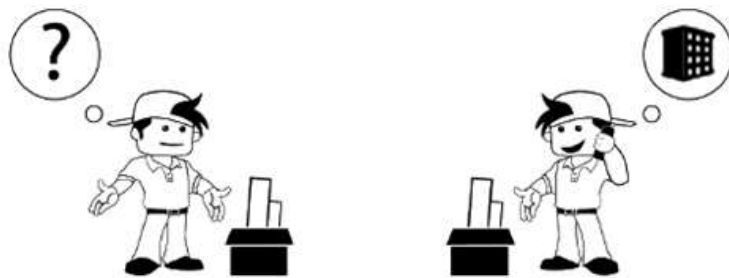

i Ask for TOPENS help by E-mail or phone anytime.

Safety Installation Information

1. READ and FOLLOW all instruction.
2. The gate opener is intended for use with Class I vehicular swing gates.

Class I denotes a vehicular gate opener (or system) dwellings, or a garage or parking area associated therewith.

Install the gate opener only when the opener is appropriate for the construction and the usage class of the gate.

3. Gate opening system designers, installers and users must take into account the possible hazards associated with each individual application. Improperly designed, installed or maintained systems can create risks for the user as well as the bystander. Gate system design and installation must reduce public exposure to potential hazards. All exposed pinch points must be eliminated or guarded.

4. A gate opener can create high levels of force during normal operation. Therefore, safety features must be incorporated into every installation. Specific safety features include safety sensors.

5. The gate must be properly installed and work freely in both directions prior to the installation of the gate opener.

6. The gate must be installed in a location so that enough clearance is provided between the gate and adjacent structure when opening and closing to reduce the risk of entrapment. Swinging gates shall not open into public access areas.

7. The opener is intended for use only on gates used for vehicles. Pedestrians must be supplied with a separate access opening. The pedestrian access opening shall be designed to promote pedestrian usage. The pedestrian access shall be located such that persons will not come in contact with the moving vehicular gate.

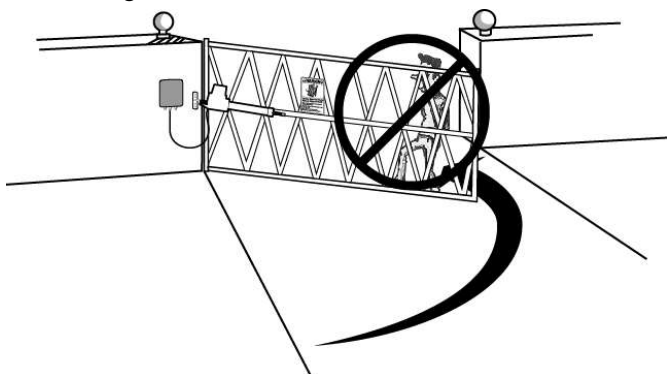

8. Pedestrians should never cross the pathway of a moving gate. The gate opener is not acceptable for

use on any pedestrian gate. Pedestrians must be supplied with a separate pedestrian access.

9. For an installation utilizing non-contact sensors (safety sensors), see product manual on the placement of non-contact sensors (safety sensors) for each type of application.

- a. Care shall be exercised to reduce the risk of nuisance tripping, such as when a vehicle trips the safety sensor while the gate is still moving.

- b. One or more non-contact sensors (safety sensors) shall be located where the risk of entrapment of obstruction exists, such as the perimeter reachable by a moving gate or barrier.

10. Never mount any device that operates the gate opener where the user can reach over, under, around or through the gate to operate the controls. Controls are to be placed at least 6' (1.8m) from any part of the moving gate.

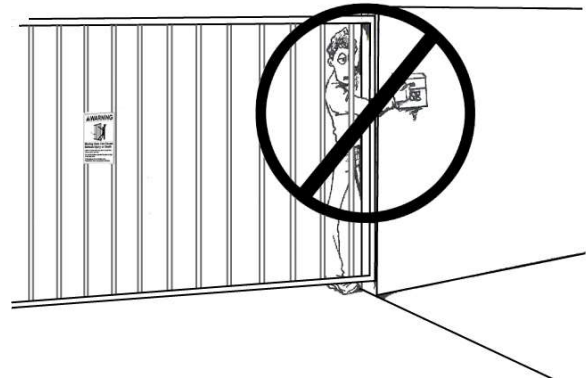

11. Controls intended to be used to reset an operator after 2 sequential activations of the entrapment protection device or devices must be located in the line of sight of the gate, or easily accessible controls shall have a security feature to prevent unauthorized use. Never allow anyone to hang on or ride the gate during the entire travel of the gate.

12. Each gate opener is provided with two safety warning placards. The placards are to be installed on the front and back of the gate where they are plainly visible. The placards may be mounted using cable ties through the four holes provided on each placard.

All warning signs and placards must be installed where visible in the area of the gate.

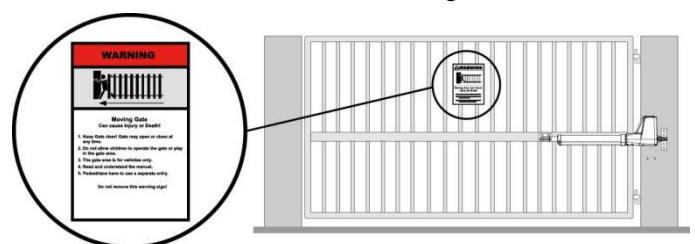

13. To AVOID damaging gas, power, or other underground utility lines, contact underground utility locating companies BEFORE digging.

14. Do not permit children to play on or around the gate and keep all controls out of their reach.

NOTE:

TOPENS Gate Operator can be used for driveway gates made by steel, wood, vinyl, and shaped as panel, tube, and chain-link. While use on solid surface gates is NOT recommended. Solid surface gates have a high resistance to the wind. *If the wind is strong enough, the operator will obstruct and stop.*

CHECK YOUR GATE

Gate MUST be level. Gate and gate post MUST be plumb. Gate MUST have a smooth bottom edge, no protrusions should exist.







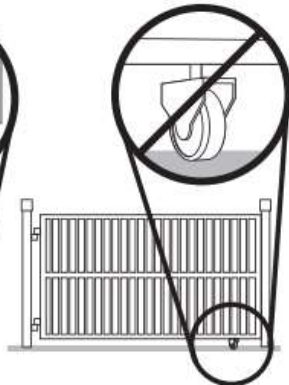
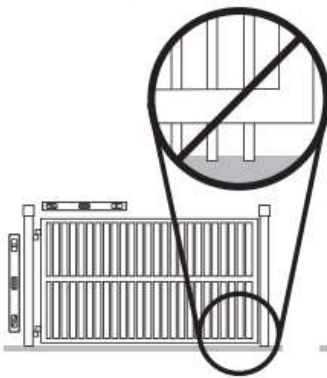



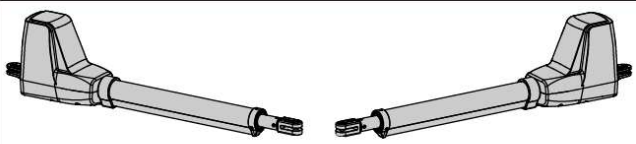









Remove ANY/ALL wheels from the bottom of gate.

Gate MUST NOT hit or drag across ground.



Gate MUST swing freely and be supported entirely by its hinges.



AT602 Parts List

 <p>Gate Opener Actuator (2 pcs)</p>		 <p>PSO Part (2 pc)</p>	
 <p>Control Box (1 pc)</p>	 <p>Remote Control (2 pcs)</p>	 <p>Release Key (2 pcs)</p>	 <p>WARNING</p> <p>Moving Gate Can cause Injury or Death!</p> <ol style="list-style-type: none"> 1. Keep Gate clear! Gate may open or close at any time. 2. Do not allow children to operate the gate or play in the gate area. 3. The gate area is for vehicles only. 4. Read and understand the manual. 5. Pedestrians have to use a separate entry. <p>Do not remove this warning sign!</p>
 <p>Post Bracket (4 pcs)</p>	 <p>Post Pivot Bracket (2 pcs)</p>	 <p>Gate Bracket (2 pcs)</p>	
<h3>Hardware</h3>			
 <p>Φ10 Washer (14 pcs)</p>	 <p>M10×200 Bolt (8 pcs)</p>		
 <p>Φ10 Lock Washer (14 pcs)</p>	 <p>M10×75 Bolt (4 pcs)</p>		
 <p>Φ8 Washer (2 pcs)</p>	 <p>M10×35 Bolt (2 pcs)</p>		
 <p>M10 Nut (14 pcs)</p>	 <p>M8×30 Bolt (2 pcs)</p>		
 <p>M8 Nut (2 pcs)</p>	 <p>12×40 Clevis Pin (2 pcs)</p>		
 <p>Hairpin Clip (4 pcs)</p>	 <p>12×30 Clevis Pin (2 pcs)</p>		





Accessories Parts (Included in some models, refers to the actual package)

 <p>JD24VY 24V Warning Light</p>	 <p>TC102 Photo Eye Beam Sensor</p>	 <p>25FT Extension 5 Cord Cable</p>
---	--	---

Optional Accessories Parts List (Available at TOPENS Store)

 <p>M12 Remote Control</p>	 <p>ERM12 External Receiver</p>	 <p>TC186-R WiFi Smartphone Remote Control with Camera</p>	 <p>TC186 WiFi Smartphone Remote Control with Camera</p>
 <p>TKP3 Wireless Keypad</p>	 <p>TC175P Wired Keypad</p>	 <p>HLR01 HomeLink Remote Control Kit</p>	 <p>TC173 Wireless Push Button</p>
 <p>TC147 Wired Push Button</p>	 <p>TRF3 Reflection Photocell Sensor</p>	 <p>TC102 Photo Eye Beam Sensor</p>	 <p>JD24VY 24V Warning Light</p>
 <p>TSP30W 30W Solar Panel Charging Kit</p>	 <p>TCS3 Solar Charge Controller</p>	 <p>25FT Extension 5 Conductor Cable</p>	<p>AT602 Gate Opener is NOT Compatible with Electric Gate Lock or Vehicle Sensor Exit Wand.</p>

Replacement Parts

 <p>PKMJ9A Control Board</p>	 <p>ALS01 Limit Switch</p>	 <p>AT6 Arm Actuator</p>	 <p>MK01 Hardware Kit</p>
---	---	--	--

WARNING: Changes or modifications not expressly specified by this user manual, TOPENS could void the warranty of this equipment.

Tools Needed:

- Power Drill
- Tape Measure
- Open End Wrenches — 14# & 17# or Adjustable Wrenches
- Wire Strippers
- C-Clamps — small, medium, and large
- Level
- Hacksaw or Heavy Duty Bolt Cutters
- Phillips Screwdriver

Technical Specifications & Features

Specifications	
Model:	AT602
Input:	110V~120V/60Hz or 220~240V/50Hz
Motor Voltage:	24VDC
Power:	2×50W
Current:	2A
Actuator Speed:	16mm/s (0.6 in/s)
Max. Actuator Travel:	385mm (15.2 in)
Ambient Temperature:	-20℃~ +50℃ (-4°F to 122°F)
Protection Class:	IP44

Gate Capacity of AT602 for Each Actuator

Gate Weight	300kg (660lbs)	✓	NR	NR	NR	NR	NR	NR
	250kg (550lbs)	✓	✓	NR	NR	NR	NR	NR
	200kg (450lbs)	✓	✓	✓	NR	NR	NR	NR
	150kg (330lbs)	✓	✓	✓	✓	NR	NR	NR
	100kg (220lbs)	✓	✓	✓	✓	✓	NR	NR
	70kg (150lbs)	✓	✓	✓	✓	✓	✓	NR
	50kg (100lbs)	✓	✓	✓	✓	✓	✓	✓
		1.2-1.8m(4-6')	2.4m (8')	3m (10')	3.6m (12')	4.3m (14')	4.8m (16')	5.5m (18')
	Gate Length							

NOTE: "NR" indicates this size and weight combination is NOT recommended for one arm actuator.

NOTE: Ball bearing hinges should be used on all gates weighing over 140kg (300 lbs).

These specifications are subject to change without notice.

Features:

- Soft start and soft stop
- Emergency release key in case of power failure
- Dual/Single gate running mode
- Adjustable opening/closing interval between master and slave gate
- Stop in case of obstruction during gate opening.
- Reverse in case of obstruction during gate closing.
- Built in adjustable auto-close (0-99 seconds)
- Built in max. Motor running time (MRT)

adjustable for multiple safety protection (1-50 seconds)

- Digital display indicates the running situation and setting menu
- Reliable electromagnetism limit for easy adjustment
- Can be equipped with a wide range of accessories
- Easy to install, and minimum maintenance requirement

Installation Overview

Pull-to-Open Gates

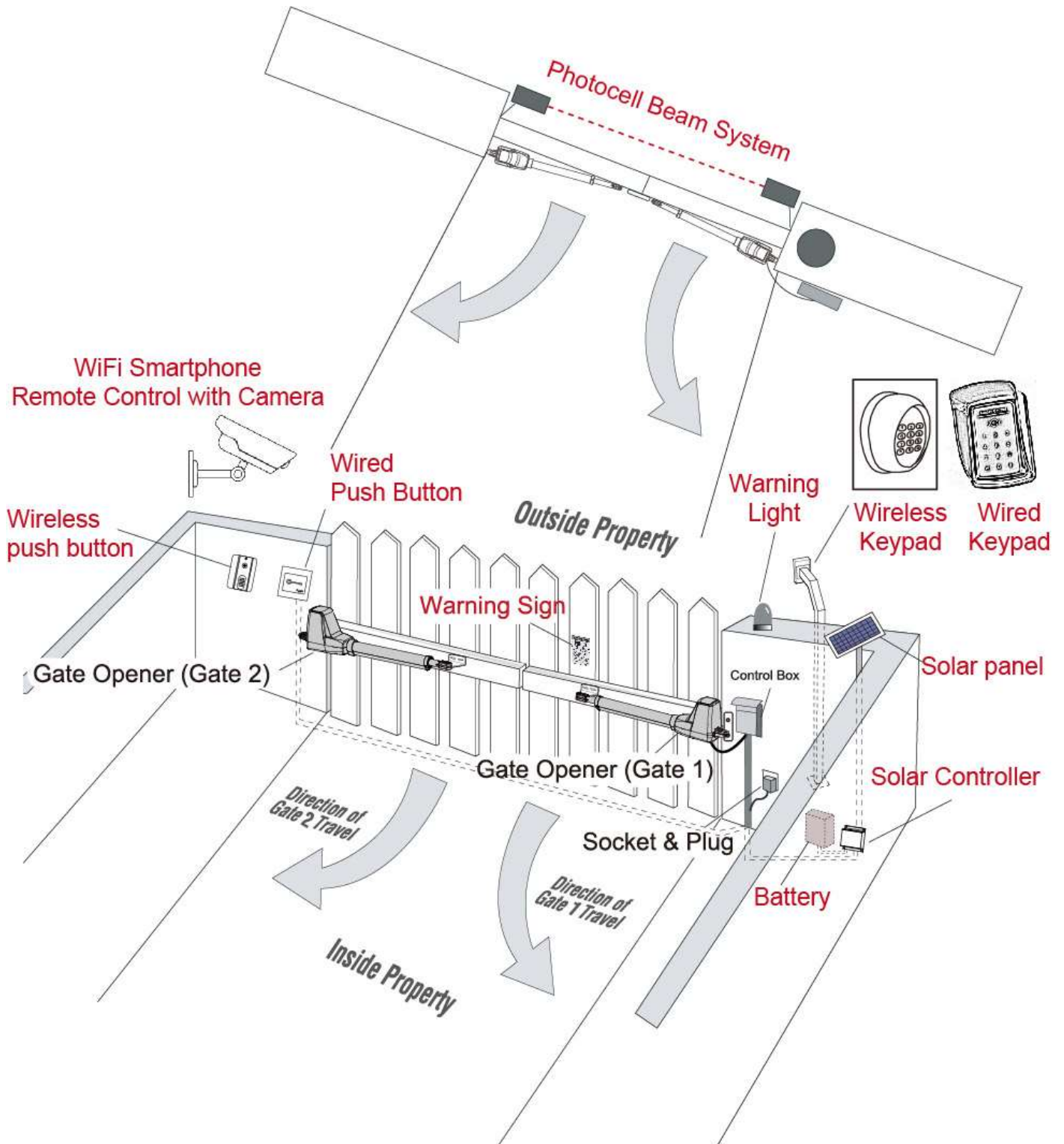

Important:

The second gate opener cable should be put into the PVC conduit (not provided) which is buried underground. This protects the cable from lawn mowers and string trimmers.

Preparation for Installation

There are two installation types for the gate opener, **Pull-to-Open** and **Push-to-Open**.

In the **Push-to-Open** installation, gate opens out from the property. A Push-To-Open Bracket (**PSO part**) is required to be used for each gate.

NOTE: Ensure the gate does not open into public areas. One more person will help when installing.

The gate opener is mounted to the gate and to the gate post. Both round and square posts can be used because the Post Brackets are curved. When mounting the Post Brackets, use bolts long enough to pass through the entire post. M10 x 200 bolts are included. Concrete anchors are not provided.

When mounting the Post Brackets to wooden posts, a larger-size washer or metal plate should be used between the bolts and the wooden post to ensure the stability of the fastening hardware. If the post is smaller than 6" diameter or square, it should be made of metal and set in cement to ensure its stability.

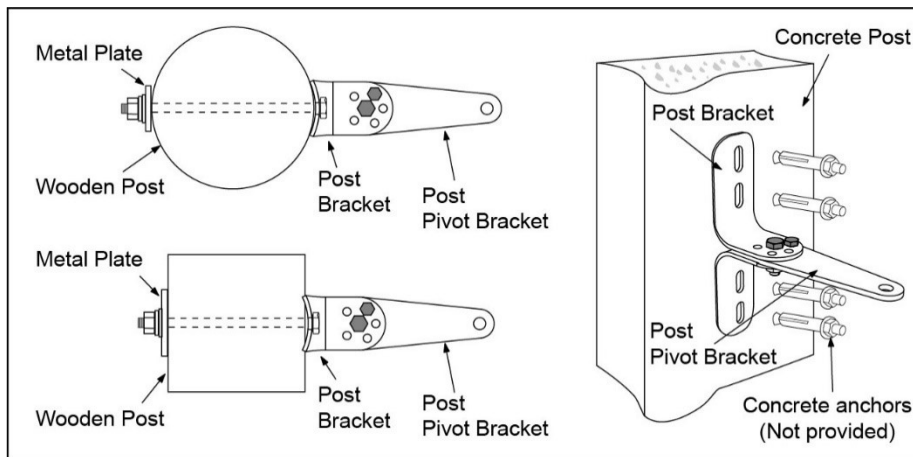

Install the Opener on the Gate – for Pull to Open

The position of Post Bracket is very important. The following illustrations and tables are required to determine the proper mounting position for the Post Bracket. The tables show the maximum opening angle of the gate for a given A and B. For example, if A is 19cm and B is 15cm, the maximum opening angle of the gate is 106°

Pull-to-Open Installation — Gate in Closed position (Moving-Rod is extended)

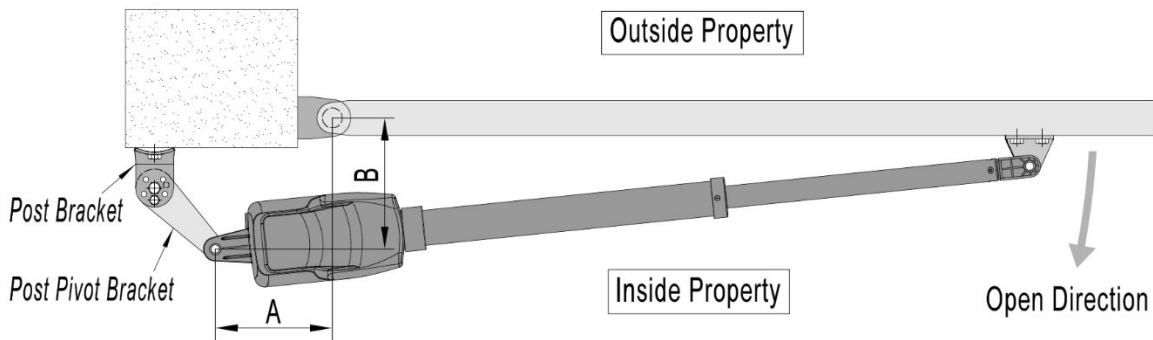

	A=13cm	A=15cm	A=17cm	A=19cm	A=21cm	A=23cm	A=25cm	A=27cm
B=13cm	91°	99°	106°	112°	105°	99°	95°	92°
B=15cm	91°	98°	105°	106°	99°	94°	91°	92°
B=17cm	91°	97°	103°	98°	93°	89°	86°	84°
B=19cm	91°	97°	98°	92°	92°	85°	82°	80°
B=21cm	91°	96°	91°	86°	83°	81°	79°	77°
B=23cm	91°	89°	85°	81°	79°	77°	75°	74°
B=25cm	88°	83°	79°	77°	75°	73°	72°	71°
B=27cm	80°	77°	75°	73°	71°	70°	69°	68°

1. Insert the bolts through the holes of post bracket and post pivot bracket as shown. Place washers and nuts on the bottom of the bolts and hand tighten.

2. Attach the gate bracket and post bracket assy. to the opener by inserting a clevis pin. Secure the clevis pins using the hairpin clips.

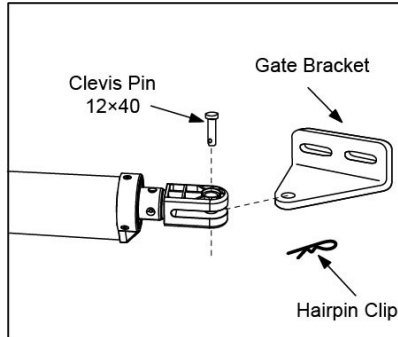
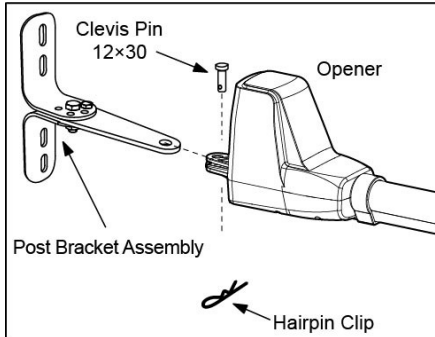
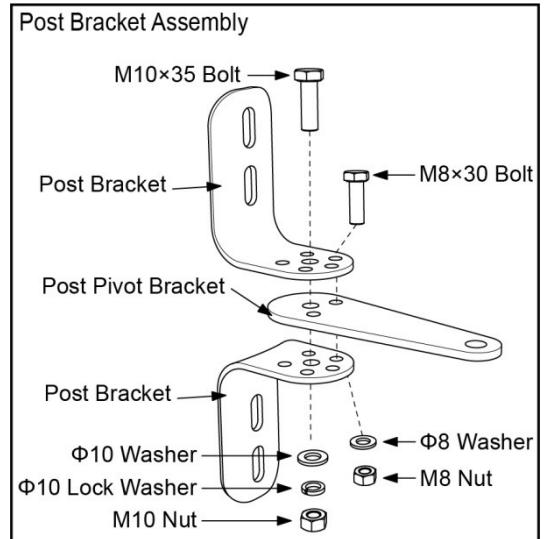

3. Insert the release key, and turn the key 90° clockwise. This releases the motor and allows the push-pull rod to be manually extended and retracted. To restore normal operation, turn the key 90° counterclockwise.

4. With the opener fully retracted and with the gate in the fully open position (for Pull-to-Open installation), place the opener with the Post Bracket Assy. and Gate Bracket on the gate post and the gate. While holding the gate opener in the level position, temporarily secure it with two C-clamps.

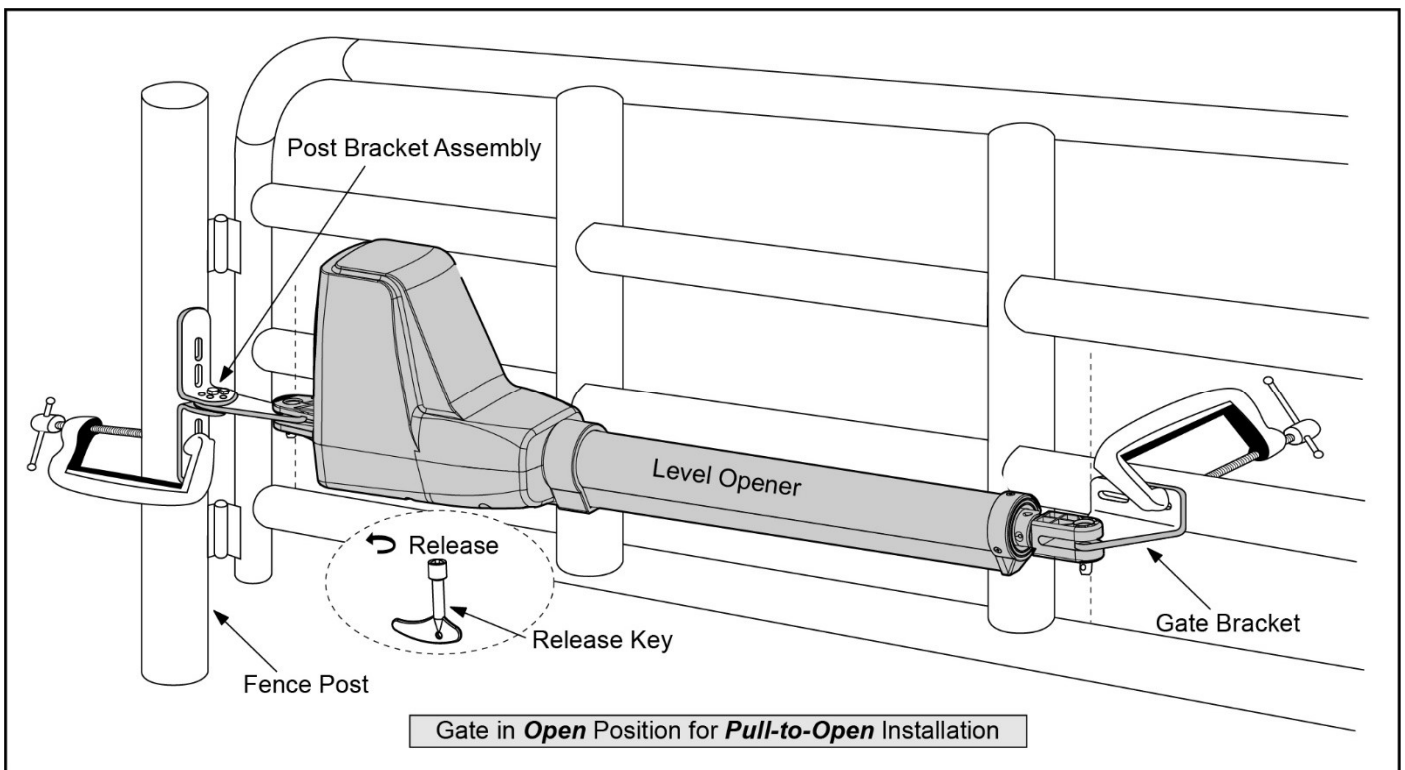

5. Make sure that there is a minimum clearance of 2.5cm between the gate and the opener and that the opener and the Post Pivot Bracket are not binding in both the gate-open and gate-closed positions. If there is not at least 2.5cm of clearance or if the opener and the Post Pivot Bracket are binding, rotate the Post Pivot Bracket and/or move the Post Bracket Assy. to obtain the minimum clearance and eliminate the binding.

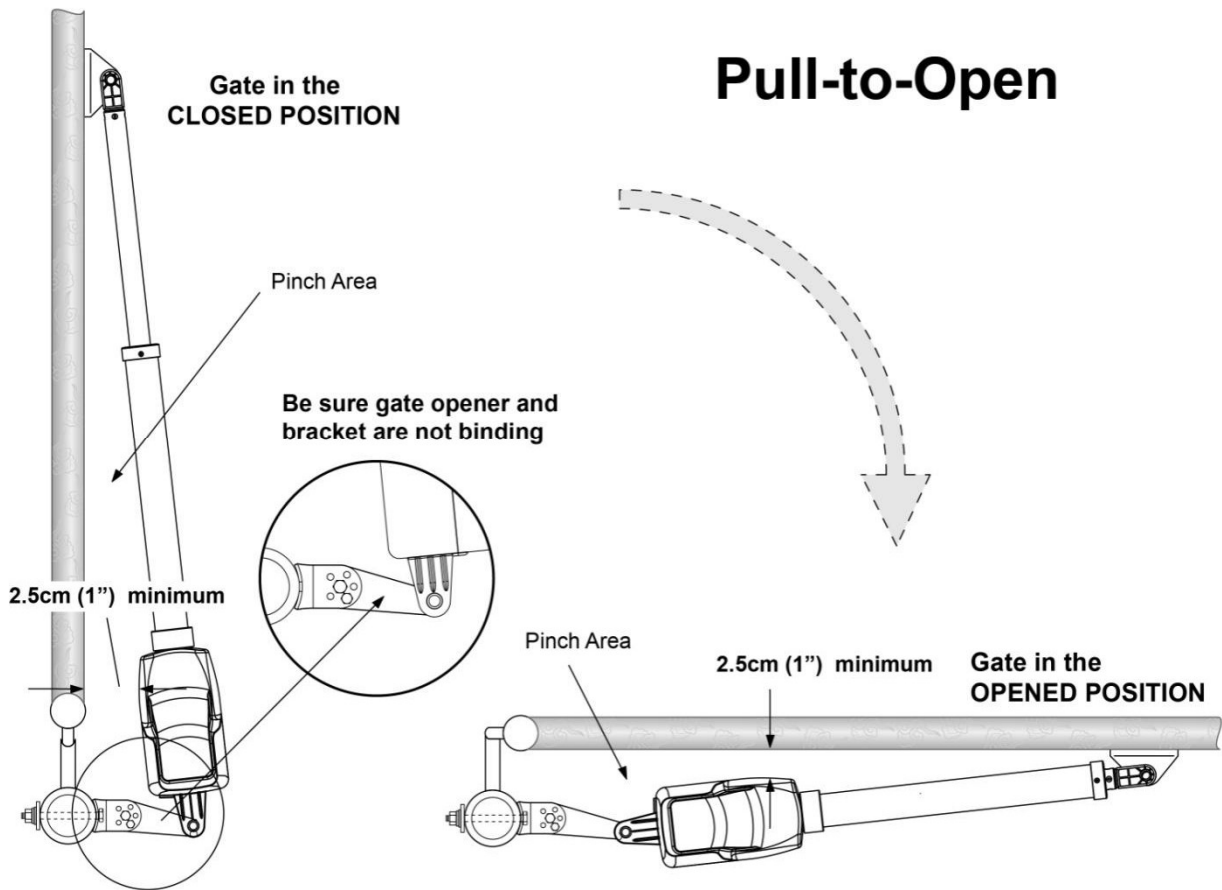

6. Sign the bolt-hole point on the gate post and gate. Do this by placing a punch or a sign in the middle of each bolt slot on the post bracket and the gate bracket. It allows slight adjustments to the post bracket. Then remove the opener and brackets assy. by taking off the C-clamps.

7. Drill 10.5 mm diameter holes through the post and the gate at the marked locations.

8. Attach the post bracket assemblies to the gate post by inserting M10 x 200 bolts through each post bracket assy. and the drilled holes in the gate post. Fasten each bolt with one \varnothing 10 washer, one \varnothing 10 lock washer, and one \varnothing 10 nut.

9. Attach the gate brackets to each gate by inserting two M10 x 75 bolts through the gate brackets and the drilled holes in the gates. Fasten each bolt with one \varnothing 10 lock washer, and one \varnothing 10 nut.

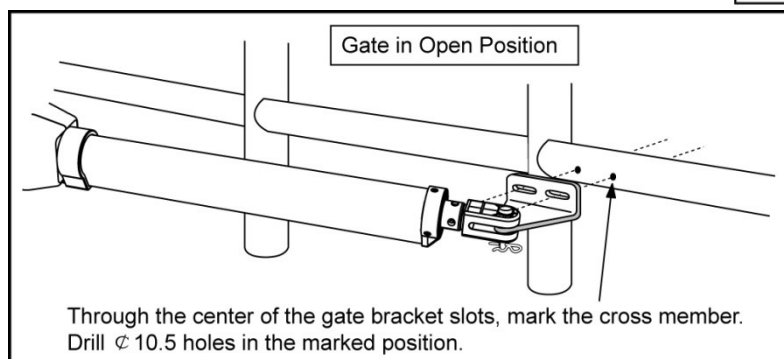
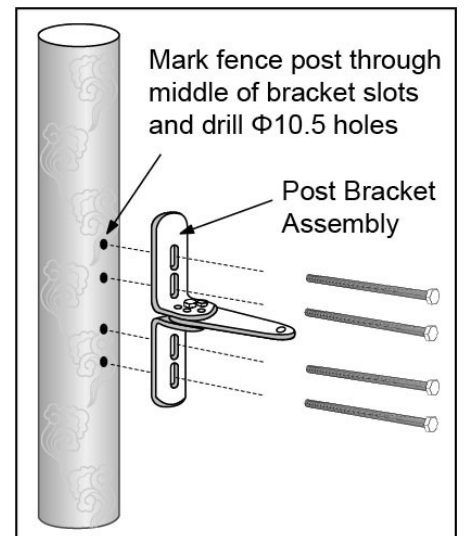

10. Cut off any part of the bolts that extend beyond the tightened nuts.

11. With the opener fully retracted and with the gate in the fully open position (for Pull-to-Open installation), insert a clevis pin through the gate opener and the Post Pivot Bracket and insert another clevis pin through the gate opener and the Gate Bracket. Secure each clevis pin with a hairpin clip.

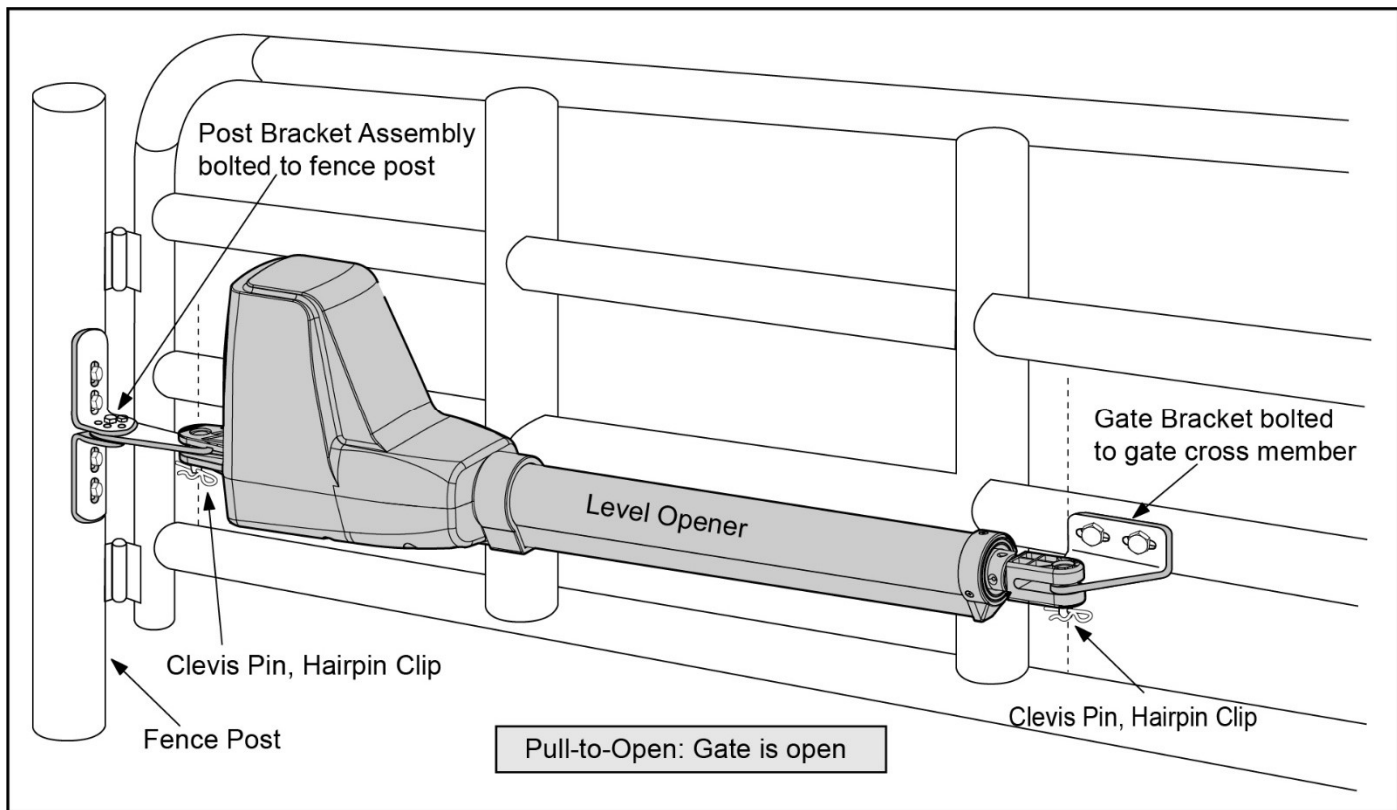

12. Insert the release key, and turn the key 90° counterclockwise. This restores normal operation.

NOTE: The setting of the PULL/PUSH TO OPEN of the control board should be in accordance with the installation.

Install the Opener on the Gate – for *Push to Open*

The position of Post Bracket is very important. The following illustrations and tables are required to determine the proper mounting position for the Post Bracket. The tables show the maximum opening angle of the gate for a given A and B. For example, if A is 17cm and B is 15cm, the maximum opening angle of the gate is 105°

Push-to-Open Installation — Gate in Closed position (Moving-Rod is retracted)

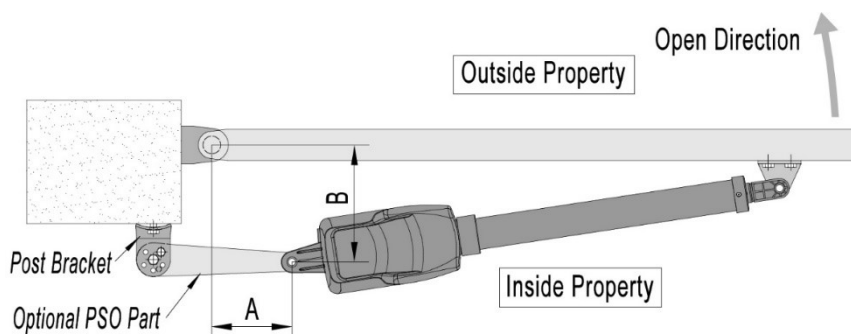

	A=17cm	A=15cm	A=13cm
B=13cm	107°	101°	94°
B=15cm	105°	100°	93°
B=17cm	104°	99°	93°
B=19cm	103°	98°	92°
B=21cm	95°	97°	92°
B=23cm	89°	97°	92°
B=25cm	83°	89°	93°
B=27cm	79°	85°	93°

1. Insert the bolts through the holes of post bracket and **PSO part (push to open bracket)** as shown. Place

washers and nuts on the bottom of the bolts and hand tighten.

2. Attach the gate bracket and post bracket assy. to the opener by inserting a clevis pin. Secure the clevis pins using the hairpin clips.

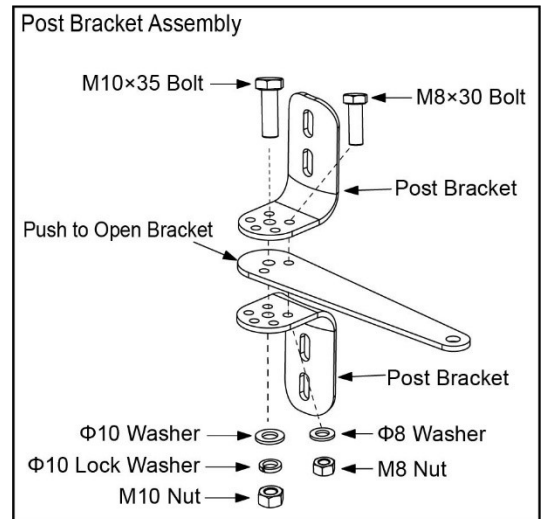
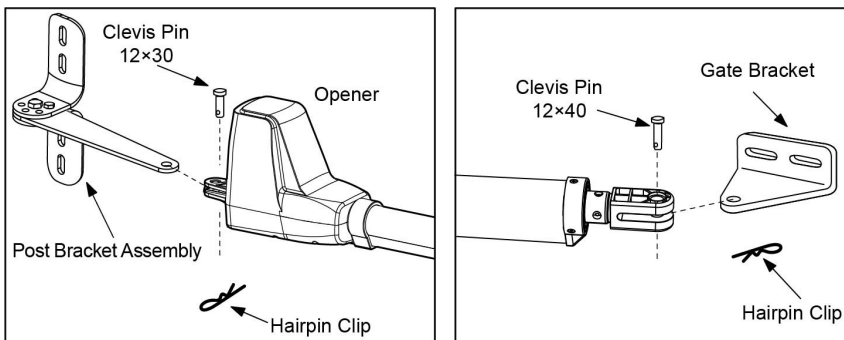

3. Insert the release key, and turn the key 90° clockwise. This releases the motor and allows the push-pull rod to be manually extended and retracted. To restore normal operation, turn the key 90° counterclockwise.

4. With the opener fully retracted and with the gate in the fully closed position (for Push-to-Open installation), place the opener with the Post Bracket Assy. and Gate Bracket on the gate post and the gate. While holding the gate opener in the level position, temporarily secure it with two C-clamps.

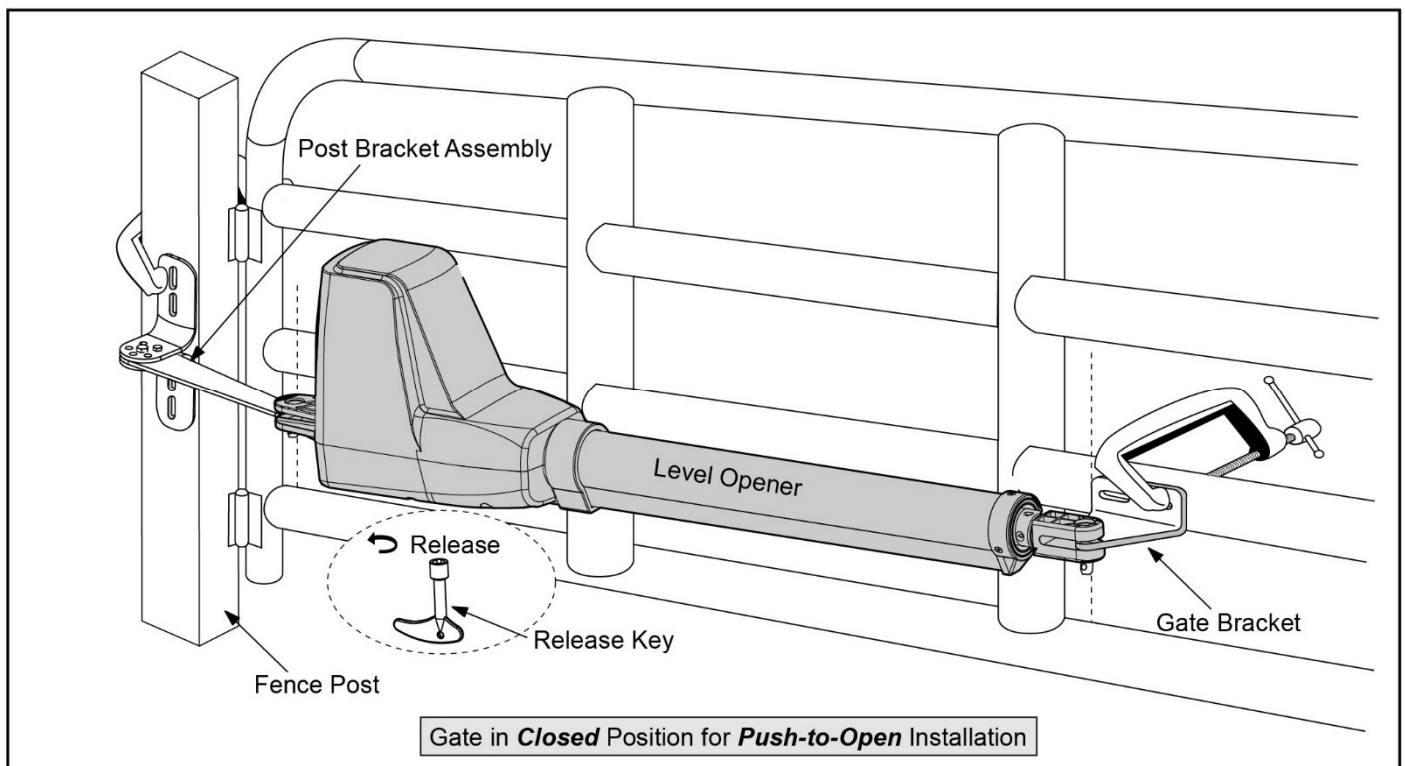

5. Make sure that there is a minimum clearance of 2.5cm between the gate and the opener and that the opener and the PSO part are not binding in both the gate-open and gate-closed positions. If there is not at least 2.5cm of clearance or if the opener and the PSO part are binding, rotate the PSO part and/or move the Post Bracket Assy. to obtain the minimum clearance and eliminate the binding.

Push-to-Open

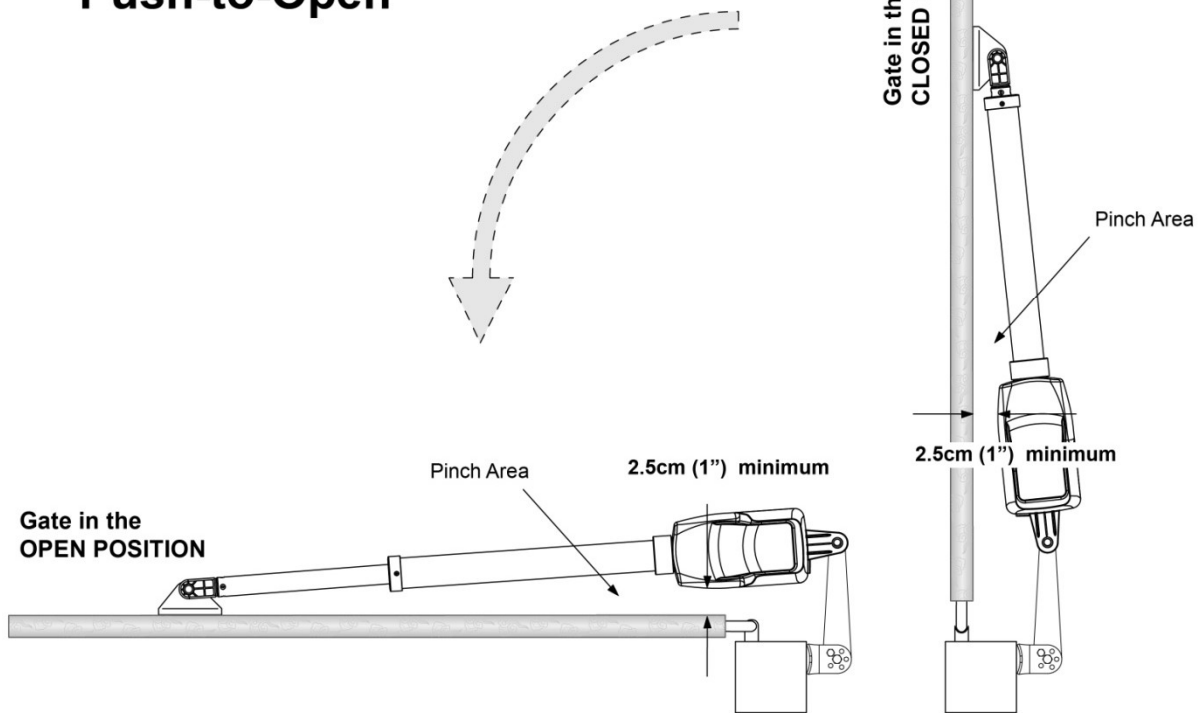

6. Sign the bolt-hole point on the gate post and gate. Do this by placing a punch or a sign in the middle of each bolt slot on the post bracket and the gate bracket. It allows slight adjustments to the post bracket. Then remove the opener and brackets assy. by taking off the C-clamps.

7. Drill 10.5 mm diameter holes through the post and the gate at the marked locations.

8. Attach the post bracket assemblies to the gate post by inserting M10 x 200 bolts through each post bracket assy. and the drilled holes in the gate post. Fasten each bolt with one \varnothing 10 washer, one \varnothing 10 lock washer, and one \varnothing 10 nut.

9. Attach the gate brackets to each gate by inserting two M10 x 75 bolts through the gate brackets and the drilled holes in the gates. Fasten each bolt with one \varnothing 10 lock washer, and one \varnothing 10 nut.

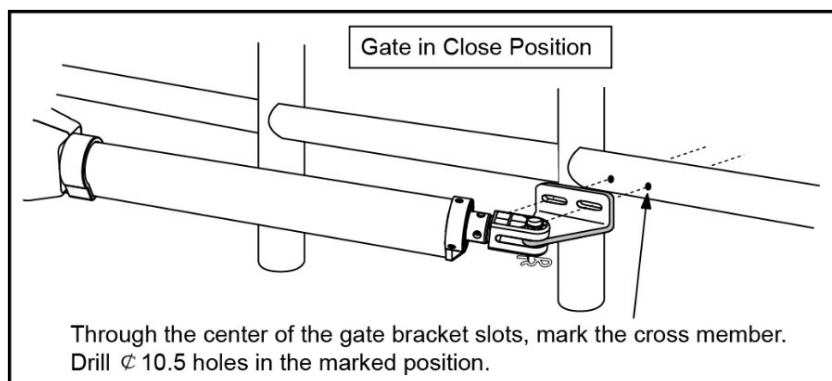
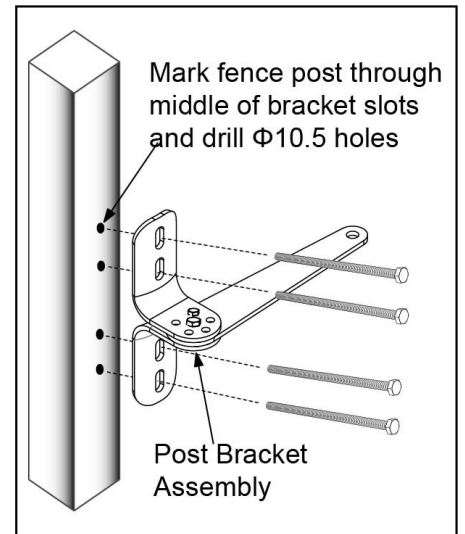

10. Cut off any part of the bolts that extend beyond the tightened nuts.

11. With the opener fully retracted and with the gate in the fully closed position (for Push-to-Open installation), insert a clevis pin through the gate opener and the PSO part and insert another clevis pin through the gate opener and the Gate Bracket. Secure each clevis pin with a hairpin clip.

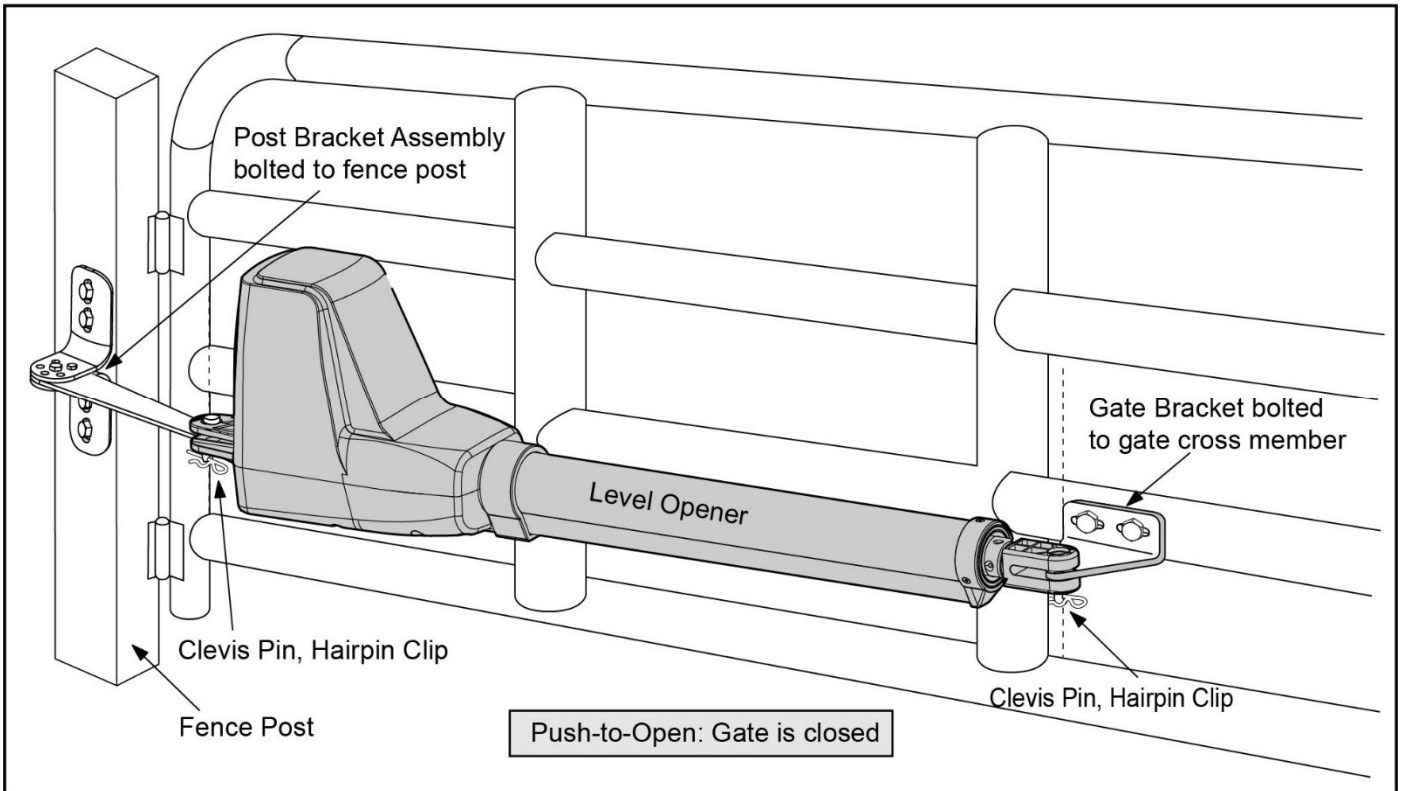

12. Insert the release key, and turn the key 90° counterclockwise. This restores normal operation.

NOTE: The setting of the PULL/PUSH TO OPEN of the control board should be in accordance with the installation.

Mounting the Control Box

Step 1

To install the control box use the deck screws (not provided). Even though the control box is waterproof designed, for safety reason and a longer service life, it is recommended to install the control box inside a

secure surface and at least 100 cm (40 inches) above the ground to avoid being flooded or buried under snow.

Step 2

Insert the power cable and cable of the first gate opener through the front strain relief and into the control box by loosening the strain relief screw located in the leftmost of outside bottom of the control box and feeding the cables into the control box. Check the length of cables is long enough to their respective terminal block in control box.

Strain Relief	
	Lock Nut
	Hub
	Sealing Nut

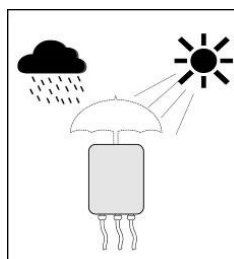

Fix control box to a secure surface by using mounting holes and screws (not provided).

CAUTION: Install the Control Box in a well ventilated place protected against rain and

sunlight.

CAUTION: Make sure the cable outlet hole in the Control Box is always down during installation so as to drain off the water.

Step 3

Insert the cable of the motor2 and alarm lamp cables into the control box through middle strain relief. Then repeat step 2.

Step 4

Insert other cables into the control box through rightmost strain relief. Then repeat step 2.

Connection of Power Supply

⚠ WARNING: NEVER connect the gate opener to the power supply before all the installations have been done.

Connect the power supply to the Control Box refers to the following illustration.

NOTE:

1. Use copper conductors to connect to the power supply terminals.
2. The wire (not provided) size should be at least 0.75mm² (18AWG) which is intended to connect the power supply.
3. Run the wires in conduit to the control box to prevent damage to the wires from lawn mowers, weed eaters and grazing animals.
4. The fuse in the control board is interchangeable. A 10a, 250vac, $\Phi 5 \times 20$ mm fuse is suitable to the control board.

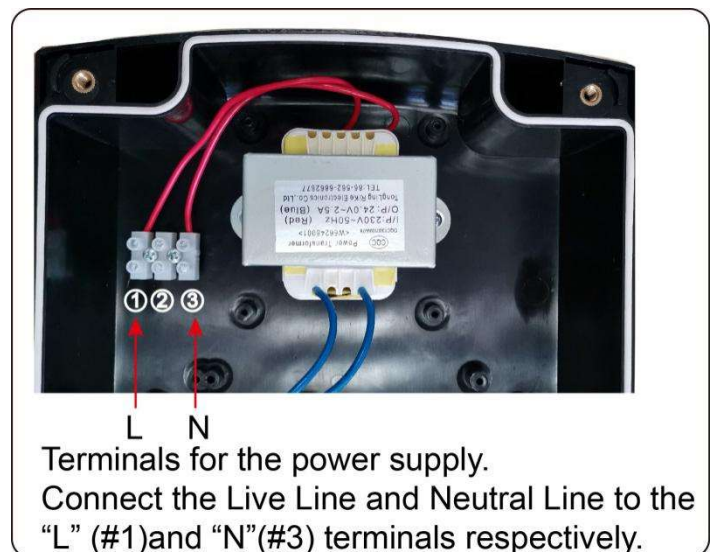

Connecting of the Control Board

Actuator 1

Insert the stripped cable wires into the appropriate terminals on the opener terminals block. The red wire should be inserted into the "MOTOR1+" terminal, the black wire into "MOTOR1-", the blue wire into ULT1, the green wire into COM, and the thin yellow wire into DLT1 terminal.

Actuator 2

Similar as the connection of Actuator 1, insert the stripped cable wires into the appropriate terminals on the opener terminals block. The red wire should be inserted into the "MOTOR2+" terminal, the black wire into "MOTOR2-", the blue wire into ULT2, the green wire into COM, and the yellow wire into DLT2 terminal.

NOTE: For dual gate mode, actuator 1 must be used for master gate. Master gate would open first and close last. If the gate opener is installed for "PUSH TO OPEN", then the P2 setting of the control board must be set to "11" (Factory default setting is 00).

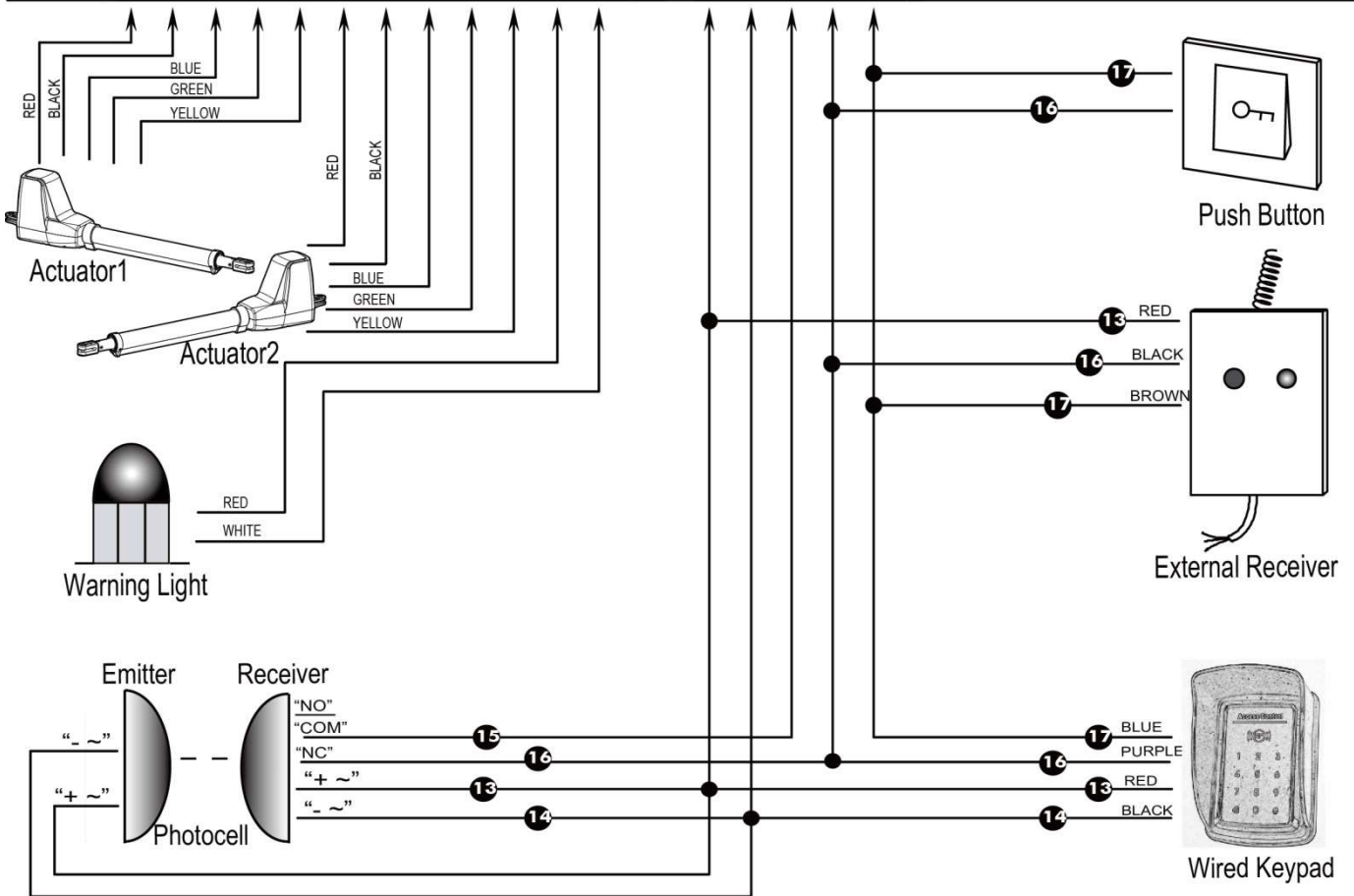
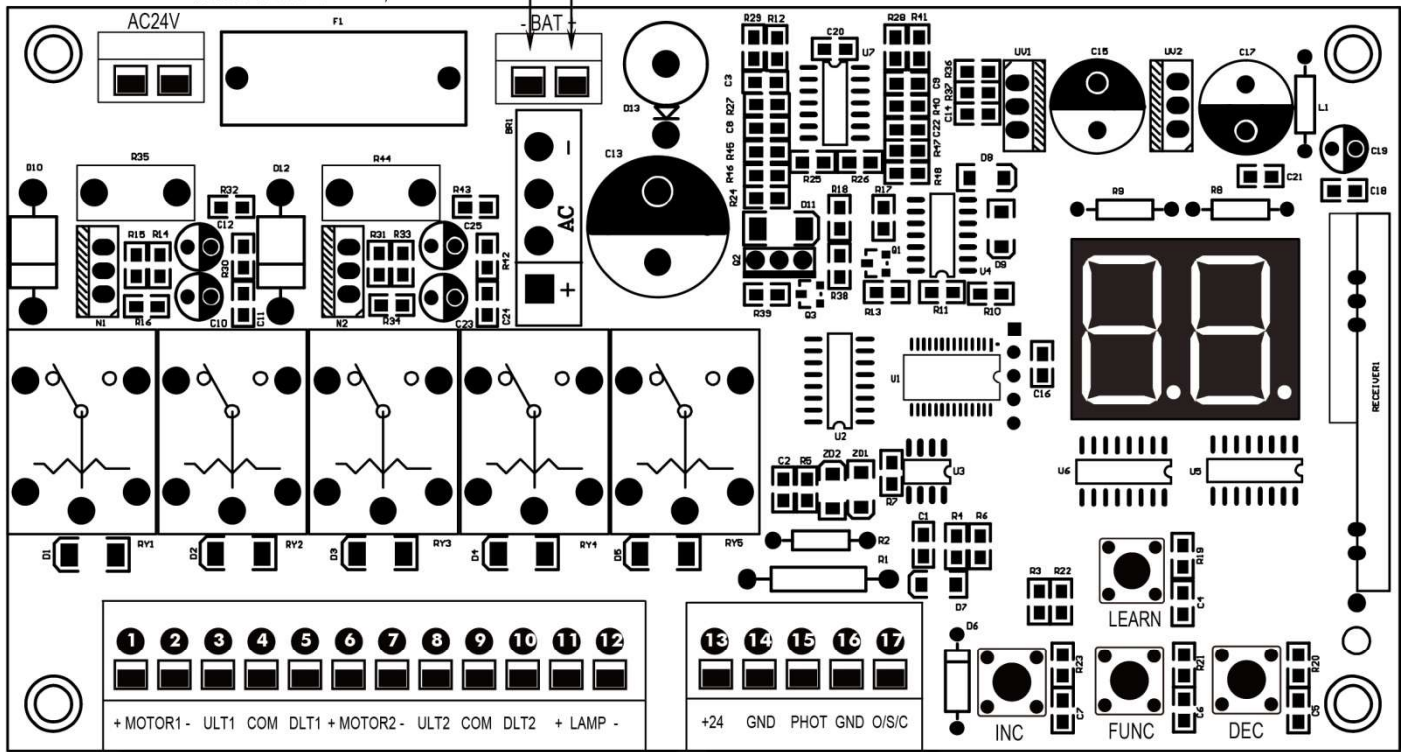
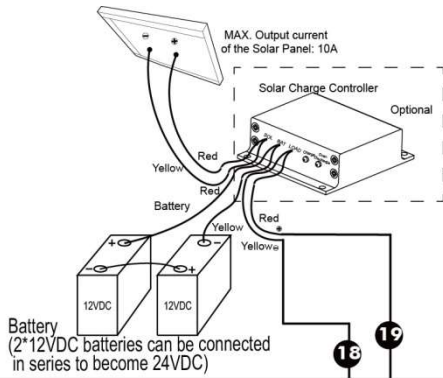

Warning Light (Included in some models, refers to the actual package)

The red wire of the warning light should be inserted into **+LAMP (#11)** terminal, the white wire into the **LAMP- (#12)** terminal.

Back-up Battery & Solar Panel & Solar Controller (optional)

The battery could be charged by the solar panel & solar controller. Please refer to the manual instruction of solar panel and controller separated for wire connection.

Photocell Beam System (PBS) (Included in some models, refers to the actual package)

Use a 2-core cable to connect the “- ~” terminal of the photocell’s emitter to the “14” terminal, the “+ ~” terminal to the “13” terminal. Also the “- ~” and “+ ~” terminals of the photocell’s receiver should be connected to the “14” and “13” terminals in parallel.

Use another 2-core cable to connect the “COM” terminal of the receiver to the “15” terminal, the “NC” terminal to the “16” terminal.

Push Button (optional)

The push button should be wired to the **GND (#16)** and **O/S/C (#17)** terminals. The gate operator works alternately by pushing the button (open-stop-close-stop-open).

External Receiver (optional)

The **BROWN** wire of the external receiver should be connected into the “17” terminal.

The **BLACK** wire of the external receiver should be connected into the “16” terminal.

The **RED** wire of the external receiver should be connected into the “13” terminal.

Wired Keypad (24VDC) (optional)

The **RED** wire of the wired keypad should be connected into the “13” terminal.

The **BLACK** wire of the wired keypad should be connected into the “14” terminal.

The **PURPLE** wire of the wired keypad should be connected into the “16” terminal.

The **BLUE** wire of the wired keypad should be connected into the “17” terminal.

How to Program or Erase the Remote

- ❖ *The remote **MUST** be programed to the opener **BEFORE OPERATING**. Please follow the steps to program the remote.*
- ❖ *Activate the opener only when gate is in full view, free of obstruction and properly adjusted. No one should enter or leave gate area while gate is in motion. **DO NOT ALLOW CHILDREN to operate push button or remote. DO NOT ALLOW CHILDREN TO PLAY NEAR THE GATE.***
- ❖ *If you purchase additional remote controls, the gate opener must be programmed to accept the new remote code.*
- ❖ *If you lose one of any remote control, please erase and reprogram all other remote controls to have a new code for safety.*

Program the remote

Press and release the learn button, the **LED** will display “Ln”, then press the key on the remote **two times** in 4 seconds, **between the two times HOLD ON FOR A MOMENT**, the **LED** will flash “Ln” for 4 seconds then back to “- -”. Now the remote has been programed successfully.

Erase all the remote codes

Press and hold the learn button until the **LED** display “dL”, release the button and the LED will be back to “- -”. Now all remote codes have been erased.

- ❖ **NOTE: Max. 8 remotes can be programmed for the opener. An External Receiver (optional) allows up to**

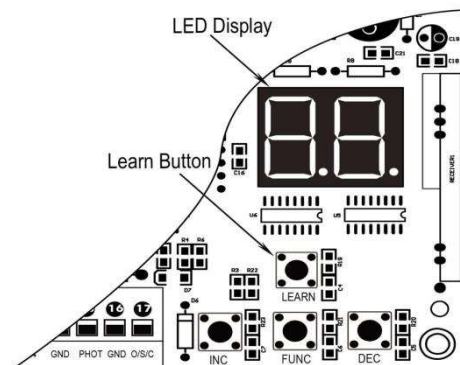

250pcs remotes to be programmed for the opener. TOPENS ERM12 Universal External Receiver is available at TOPENS Store.

✧ TOPENS ERM12 Universal External Receiver is also compatible with other brand swing gate opener, sliding gate opener and garage door opener.

How to Use the Remote to Operate Your Gate Opener

Each remote has four buttons, from top to bottom are separately A, B, C and D. You may use this remote to operate as many as 4 sets TOPENS swing gate openers or 1 set TOPENS sliding gate opener and 2 sets TOPENS swing gate openers.

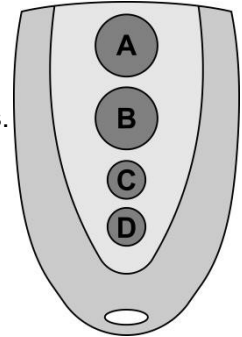

1. Use this remote to only operate TOPENS swing gate opener
A, B, C and D four buttons share same function once they are programmed with TOPENS swing gate opener. You may choose any button to program it with our swing gate opener. Every press of the button is able to activate the gate opener to work alternately (open-stop-close-stop-open).

2. Use one remote to operate TOPENS swing gate opener & sliding gate opener at the same time
All of TOPENS sliding gate opener have midway mode. Button B is designed to realize midway function (refer to more details in our TOPENS sliding gate opener manual). So it is must program button A with sliding gate opener, while you may program either C button or D button with TOPENS swing gate opener.

Wireless Keypad Programming

You can follow the below steps to program wireless keypad to the opener. Press the **LEARN** button until the LED display “Ln”, and then release the button. Then press “OK” button on keypad and LED will flash “Ln” for 3 seconds and then back to “- -” which indicates the keypad has been programmed successfully. You can use the default password “888888” to operate the opener after programming. You can press “PIN” “8 8 8 8 8 8” and then press “OK” to confirm to operate the opener.

Also you can change the password of the keypad follow the below steps. Press “PIN” and then input the six digits old password and then press “PIN” again, the LED will display “CH”. Input the six digits new password and then press the “PIN” to confirm the new setting, LED will flash “CH” for 3 seconds and then back to “- -” which indicates the password has been changed successfully. You can press “PIN” “6 digits new password” and then press “OK” to confirm to operate the opener.

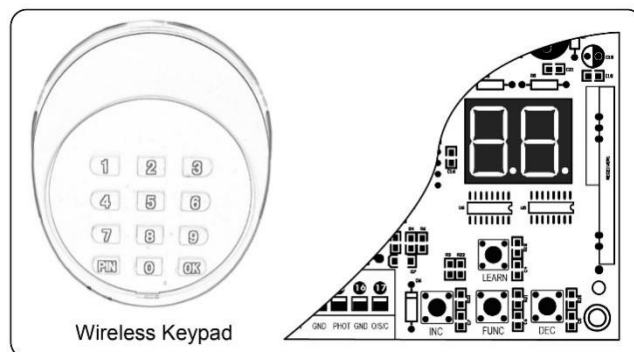

NOTE: Every step for pressing button during program must be finished within 1 second to ensure successful programming.

Setting of the Control Board

⚠ WARNING: Ensure the gate opener is Power Off when you make any adjustment of the gate opener. Keep away from the path of the gate during you set the gate opener system in case of the unexpected gate moving. Carefully adjust settings to avoid the risk of machine damage and injury or death. Always ask the help of professional technician /electrician if you have any question.

1. Check again for completed and correct assembly of your swing gate opener and gate. Plug the Power Cord into the nearest AC outlet. The Digital Display on the Control Board will flash with “- -”. The unit is in standby.

NOTE: You can follow these steps to enter the setting menu, finish **all the setting program**, and then go back to the stand-by state.

If you only need to adjust **one setting program**, press and hold “FUNC” button for more than 4 seconds. The digital display will indicate “P1”, then press “FUNC” button repeatedly to get the **desired setting program of “P?”**, then press the “INC” and “DEC” buttons to adjust correspondingly. When the setting is finished, press the “FUNC” button repeatedly to store the data, until the digital display on the control board flashes with “- -”, the unit goes back to the standby state.

2. Single/Dual Gate Set

Press and hold the “FUNC” button for more than 4 seconds. The Digital Display will indicate “P1”. Gate opener is on the SINGLE/DUAL Gate setting. Press the “INC” and “DEC” buttons respectively to following modes:

“01” shown in Digital Display, it is Single Actuator 1 (Gate 1) mode. “10” shown in Digital Display, it is Single Actuator 2 (Gate 2) mode. “11” shown in Digital Display, it is Dual actuator mode.

Press the “FUNC” button to store the data when the single or dual gate is chosen. The Digital Display will indicate “P2”. Now single/dual gate set is finished.

(Factory set is “11”)

3. Set “PUSH TO OPEN” or “PULL TO OPEN”

When Digital Display indicates “P2”, the gate opener is on the **PUSH/PULL TO OPEN** Setting. Press the “INC” and “DEC” Buttons respectively to follow modes:

“00” shown in Digital Display, which means gate opens into the property (pull to open).

“11” shown in Digital Display, which means gate opens out from the property (push to open).

Press the “FUNC” button to store the data when the open mode is chosen. The Digital Display will indicate “P3”. Now **PUSH/PULL TO OPEN** Setting is finished.

(Factory set is “00”)

4. Set the Open Interval between Master and Slave Gate

When the Digital Display indicates “P3”, the gate opener is on the Open Interval between Master/Slave Gate Setting.

The open interval can be adjusted by pressing the “INC” and “DEC” Buttons respectively. The Digital Display will show “0”-“9”, which indicates the interval time “0” means the Master and Slave gates open simultaneously.

“1” means the Master Gate starts to open 1 second before Slave gate starts to open. Max. open interval is 9 seconds. Each time you press and release the “INC” button, the figure increases by 1, and the Master gate starts to open 1 more second earlier. Each time you press and release the “DEC” button, the figure decreases by 1, and the interval decreases by 1 second.

(Factory set is 3 seconds)

Press the “FUNC” button to store the data when the open interval is set. The Digital Display will indicate “P4”. Now Open Interval Set is finished.

5. Set the Close Interval between Master and Slave Gate

When the Digital Display indicates “P4”, the gate opener is on the Close Interval between Master/Slave Gate Setting.

The close interval can be adjusted by pressing the “INC” and “DEC” buttons respectively. The Digital Display

will show "0"- "9", which indicates the interval time "0" means the Master and Slave gates close simultaneously. "1" means the Slave Gate starts to close 1 second before Master gate starts to close. Maximum close interval is 9 seconds. Each time you press and release the "INC" button, the figure increases by 1, and the Slave gate starts to close 1 more second earlier. Each time you press and release the "DEC" button, the figure decreases by 1, and the interval decreases by 1 second.

(Factory set is 3 seconds)

Press the "FUNC" button to store the data when the close interval is set. The Digital Display will indicate "P5". Now Close Interval Set is finished.

6. Adjust the Obstruction Sensitivity/Stall Force

When the Digital Display indicates "P5", the gate opener is on the Stall Force Adjustment.

Without a properly installed safety reversal system, person (particularly small children) could be SERIOUSLY INJURED or KILLED by a closing gate.

*Too much force on gate will interfere with proper operation of safety reversal system.

*NEVER increase force beyond minimum amount required to close gate.

*NEVER use force adjustments to compensate for a binding or sticking gate.

* If one control (force or travel limits) is adjusted, the other control may also need adjustment.

* After ANY adjustments are made, the safety reversal system MUST be tested. Gate MUST BE TESTED. Gate MUST reverse on contact with a rigid object.

The opener is equipped with an obstruction sensing feature. If the gate encounters an obstruction the opener will automatically reverse direction and stop. Based on the length and weight of the gate it may be necessary to make force adjustments. The force adjustment should be high enough that small objects such as branches or wind will not cause nuisance interruptions but low enough to prevent serious injury to a person or a vehicle.

6-a Adjust Stall Force of Gate Opener 1

Now we adjust the stall force of gate 1

The stall force of gate opener1 is adjusted by pressing "INC" and "DEC" buttons respectively. The Digital Display will show "1"- "9" which indicates the stall force levels. "1" means the minimum force, and "9" is the maximum force. Each time you press and release the "INC" button, the figure increase by 1, and the force increases to a higher level. Each time you press and release the "DEC" button, the figure decreases by 1, and the force decreases to a lower level. Press "FUNC" to store the data. The Digital Display will indicate "P6". Now stall force of gate opener 1 is finished.

(Factory set is Level 3)

6-b Adjust Stall Force of Gate Opener 2

When the Digital Display indicates "P6".you can adjust force of gate opener 2.

Please perform the same procedure as gate opener 1 (6-a).

Press the "FUNC" button to store the data when stall force of gate opener 2 is set. Then "P7" will be shown on the Digital Display.

NOTE: You may need to increase the stall force in cold weather due to increased resistance from gate hinges. The gate opener's opening/closing force is adjusted automatically according to stall force adjustment.

7. Adjust the Max Motor Running Time (MRT) of the MOTOR for gate opener

The maximum running time of the MOTOR can be set to make the motor stop running after a specified period even if the limit switch is invalid or the clutch is detached.

7-a. Adjust the MRT of MOTOR1

When the Digital Display indicates "P7", you can adjust the MRT of MOTOR1.

The MRT of MOTOR1 is adjusted by pressing "INC" and "DEC" buttons respectively. The Digital Display will show "01"- "50" which indicates the MRT of MOTOR1 from 1 to 50 seconds.

You can hold pressing the "INC" or "DEC" button for more than 1 second to speed up the setting. Press the

“FUNC” button to store the data when you finish setting. The Digital Display will indicate “P8”.

(Factory default setting is “40” seconds)

7-b. Adjust the MRT of MOTOR2

When the Digital Display indicates “P8”, you can adjust the **MRT** of MOTOR2.

Please perform the same procedure as adjusting MOTOR1 (7-a).

Press the “FUNC” button to store the data when you finish setting. The Digital Display will indicate “P9”. Now MOTOR2 adjustment is finished.

8. Set the Safety Photocell Beam System (PBS) (Optional)

When the Digital Display indicates “P9”, the gate opener enters PBS set mode.

You can press and release the “INC” or “DEC” button to set or shut off the PBS function. The Digital Display indicates “11”, the PBS is available. The Digital Display indicates “00”, the PBS is null.

Note: If the “11” is be set, the gate opener won’t work until the PBS system is equipped. The PBS system works only when gate opener is closing. The gate opener will return to its open position when the obstruction blocks the beam from photo eye.

Press the “FUNC” button to store the data when the PBS is set. The Digital Display will indicate “PA”.

(Factory set is “00”)

9. Set the Automatic Closing Time

When the Digital Display indicates “PA”, the gate opener enters into the setting of automatic closing time mode. Press and release the “INC” or “DEC” button, the Digital Display will show a “01”-“99” which indicates the current automatic closing time. The minimum time is 1 second, 99 seconds maximum. Each time you press and release the “INC” button, the figure increases by 1, and the timing increases by 1 second. Each time you press and release the “DEC” button, the figure decreases by 1, and the timing decreases by 1 second. When the timing is “00”, the automatic closing function is shut off and the gate will stay open.

(Factory set is 60 seconds)

Press the “FUNC” button to store the data when the desired automatic closing time is set. The Digital Display will indicate “Pb”.

⚠ Important Note: When the auto close function is enabled, the photocell sensor is highly recommended to be installed with the gate opener for safety.

10. Set the Period of Soft Start

When the Digital Display indicates “Pb”, the gate opener is ready for setting period of soft start.

You can press the “INC” or “DEC” button to set the period of soft start. There is 1-9 seconds available in setting. Press the “FUNC” button to store the data when the period is set. The Digital Display will indicate “PC”.

(Factory set is 3 seconds)

11. Set the Fast Running Period (FRP) to Achieve Soft Stop Function (SPP)

When the Digital Display indicates “PC”, the Fast Running Period for opening or closing gate is adjustable by pressing “INC” and “DEC” buttons respectively, and the Soft Stop Function is achieved simultaneously.

The Soft Stop means the gate opener runs at slow speed during the last period before the gate completely closes. The Soft Stop Period is unavailable by direct adjust but available through adjusting the Fast Running Period.

There are two running speeds designed in program, i.e. Fast Running Speed and Soft Running Speed. The Fast Running Period is adjustable from 1 to 28 sec. Factory default setting is 15 sec.

Since the GATE OPENING OR CLOSING RUNNING PERIOD (GRP) = SOFT START PERIOD (STP) + FAST RUNNING PERIOD (FRP) + SOFT STOP PERIOD (SPP), the SPP could be extended by shortening the FRP when the GRP and STP are fixed. In other words, $SPP = GRP - STP - FRP$.

Similarly, the Soft Stop Period (SPP) can be shortened through extending the Fast Running Period (FRP).

E.g. When the Soft Start Period (STP) is set at 3 sec, and the GRP is 23 sec (you can calculate the GRP period by yourself, from “the arm actuator starting to move **on the fully open position**” to “the arm arriving **at the fully close position**”), how can we get 4 sec of Soft Stop Period (SPP) to meet the requirement? The answer is

clear, i.e. we may set the Fast Running Period (FRP) at 16 sec ($23 - 3 - 4 = 16$ sec).

12. Return to Factory Set

When the Digital Display indicates “Pd”, press and release the “INC” or “DEC” button. All data will return to factory set, the Digital Display indicates “dF”.

13. If all of data is set and no other change needed, press “FUNC” Button. “- -” appears on the Digital Display, and the opener enters standby mode.

Indicate Illustration on the Digital Display When Gate Opener is Running

The left image on Digital Display symbolizes motor of gate opener 2 when the gate opener is running. The right image on Digital Display symbolizes motor of gate opener 1.

When the motor is run to gate -open direction or gate -close direction, the image on Digital Display indicates “n” or “u” respectively.

When the motor is not running, the Digital Display indicates “- -”.

Adjusting the Limit Switch

Note: Before adjusting the limit switch, refer to the chapter of “Install the Opener on the Gate”, and make sure that the rod is fully retracted when the gate is in the fully open position (for Pull-to-Open installation), or in the fully closed position (for Push-to-Open installation). Make sure that currently the rod is fully retracted.

1 For Pull-to-Open Installation, adjust the limit switch to determine the closed position:

Turn on power to operate the gate opener, then the arm extends to close the gate.

If the arm closes over the desired closed position, press the remote control to stop the opener. Use a screwdriver to loosen the screw of the limit, slightly slide the limit switch **inwards**.

If the arm closes halfway and fails to get to the desired closed position, slightly slide the limit switch **outwards**.

Please **repeat** the above steps, until the arm could arrive and automatically stop at the desired close position. Then tighten the screw firmly.

Limit setting for master gate is finished now. The slave gate is totally the same.

2 For Push-to-Open Installation, adjust the limit switch to determine the open position:

Turn on power to operate the gate opener, then the arm extends to open the gate.

If the arm opens over the desired open position, press the remote control to stop the opener. Use a screwdriver to loosen the screw of the limit, slightly slide the limit switch **inwards**.

If the arm opens halfway and fails to get to the desired open position, slightly slide the limit switch **outwards**.

Please **repeat** the above steps, until the arm could arrive and automatically stop at the desired open position. Then tighten the screw firmly.

Limit setting for master gate is finished now. The slave gate is totally the same.

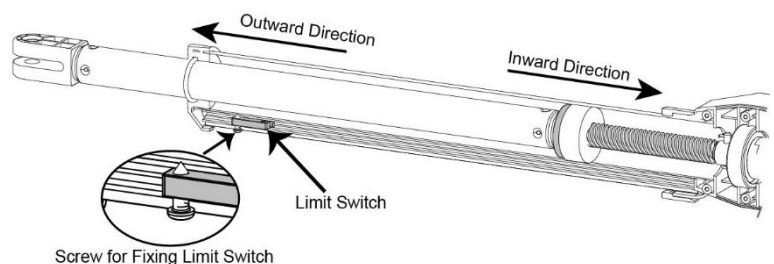

How to Operate

The user may operate the opener once all adjustment setting is finished.

With the gate in its closed position, press and release the remote control, the gate will move to the programmed opening position and stop.

With the gate in its opened position, press and release the remote control, the gate will move to the programmed closing position and stop.

While the gate is moving, press and release the remote control, the gate will stop moving immediately. The next command from the remote will reverse the gate direction and the gate will stop at its programmed opening/closing position.

The gate will stop in case of obstruction during opening. The command from the remote control will reverse the gate direction and the gate will stop at its programmed closing position.

The gate will reverse in case of obstruction or stall force during closing, and it will move to the programmed opening position.

NOTE: The Obstruction Sensitivity /Stall Force is adjustable in 9 levels.

Maintenance

 **Warning:** *Disconnect power before servicing.*

1. Using a clean, dry cloth to wipe the gate opener shaft, and then apply a silicone spray to reduce its friction. In cold climates where temperatures reach 1°C (30°F) or less, spray silicone on the actuator every 4~6 weeks to prevent freeze up.
2. Regularly check gate hinges to make sure gate is swinging smoothly and freely. Grease hinges if needed.
3. Check your installation periodically, as hardware and posts will shift. Brackets may need to be adjusted or hardware may need to be tightened.
4. Maintain the area around your gate. Keep the areas free of objects that can prevent the gate swinging freely.

NOTES:

1. *Inspection and service should always be performed anytime a malfunction is observed or suspected.*
2. *It is suggested that while at the site voltage readings be taken at the operator. Using a Digital Voltmeter, verify that the incoming voltage to the opener it is within ten percent of the opener's rating.*
3. *Refer to the instructions on how to check gate force and sensitivity adjustments.*



Reference No. : WTN19N10070825J
Applicant : HANGZHOU SANFORD TOOLS CO., LTD
Address : 8 SHENG DI ROAD, YUHANG TOWN, HANGZHOU
311121, CHINA
Manufacturer : HANGZHOU SANFORD TOOLS CO., LTD
Address : 8 SHENG DI ROAD, YUHANG TOWN, HANGZHOU
311121, CHINA
Product : Swing gate opener
Model No. : LM602, LM601, AT602, AT601
230V~, 50Hz, -20-50°C, 4Nm, IP44, Class II
Technical data : LM602, AT602: 120W
LM601, AT601: 60W

Test Standards:

EN 60335-1:2012+A11:2014+A13:2017
EN 60335-2-103:2015
EN 62233:2008

The above product has been tested by us with the listed standards and found in compliance with the European Directive LVD 2014/35/EU and MD 2006/42/EC. It is possible to use CE marking to demonstrate the compliance with LVD and MD Directive.

Household and similar electrical appliances

Part 1: General requirements

Part 2-103: Particular requirements for drives for gates, doors and windows

Measurement methods for electromagnetic fields of household appliances and similar apparatus with regard to human exposure

The referred test report(s) show that the product complies with standard(s) recognized as giving presumption of compliance with the essential requirements in the above mentioned EU Directive. Other relevant Directives have to be observed.

After preparation of the necessary technical documentation as well as the verification of conformity, the CE marking as shown below can be affixed on the equipment.



The statement is based on a single evaluation of the sample of above mentioned product. It does not imply an assessment of the whole production.

Waltek Services (Ningbo) Co., Ltd.

Hotline: 400-840-2288 E-mail: info@waltek.com.cn
Http://www.waltek.com.cn



Reference No. : WTN19N10070825J
 Applicant : HANGZHOU SANFORD TOOLS CO., LTD
 Address : 8 SHENG DI ROAD, YUHANG TOWN, HANGZHOU
 311121, CHINA
 Manufacturer : HANGZHOU SANFORD TOOLS CO., LTD
 Address : 8 SHENG DI ROAD, YUHANG TOWN, HANGZHOU
 311121, CHINA
 Product : Swing gate opener
 Model No. : LM602, LM601, AT602, AT601
 230V~, 50Hz, -20-50°C, 4Nm, IP44, Class II
 Technical data : LM602, AT602: 120W
 LM601, AT601: 60W

Test Standards:

EN 60335-1:2012+A11:2014+A13:2017
 EN 60335-2-103:2015
 EN 62233:2008

The above product has been tested by us with the listed standards and found in compliance with the European Directive LVD 2014/35/EU and MD 2006/42/EC. It is possible to use CE marking to demonstrate the compliance with LVD and MD Directive.

Household and similar electrical appliances

Part 1: General requirements

Part 2-103: Particular requirements for drives for gates, doors and windows

Measurement methods for electromagnetic fields of household appliances and similar apparatus with regard to human exposure

The referred test report(s) show that the product complies with standard(s) recognized as giving presumption of compliance with the essential requirements in the above mentioned EU Directive. Other relevant Directives have to be observed.

After preparation of the necessary technical documentation as well as the verification of conformity, the CE marking as shown below can be affixed on the equipment.



The statement is based on a single evaluation of the sample of above mentioned product. It does not imply an assessment of the whole production.

Waltek Services (Ningbo) Co., Ltd.

Hotline: 400-840-2288 E-mail: info@waltek.com.cn
 Http://www.waltek.com.cn

Trouble Shooting



**Need help or have questions? DO NOT RETURN to the store.
Visit www.topens.com to CONTACT US.**

◆ Opener does not run. Digital Display indicator is not on.

1. Check if the power is on. Check the input voltage at the terminal. It should be local AC power. If the voltage measures 0 using the voltmeter, the power cable may be damaged.
2. Check if the output voltage of the transformer is 24Volts AC. If the voltage measures 0, the transformer may be overheated or damaged. Turn power off and allow transformer to cool for several minutes then reset. Replace the transformer if the symptom still exists.
3. Check the fuse in the control board. Replace the fuse if necessary.

◆ Opener powers up but does not run.

1. Check if the arm cable is loosening. Verify that all of the wires of the arm are secure to the terminals of the control board.
2. Arm is incorrectly installed. Disconnect the motor housing from the arm and check if the arm moves freely.
3. Gate is excessively heavy or hinges are bad. Check the gate is within the ratings for this product. Disconnect the arms and verify that both gates swing easily. Lubricate or replace hinges as necessary.
4. Bad control board. Call technical support for help with replacement parts.

◆ Gate stops immediately after it starts moving.

1. Obstruction sensed. Check safety devices and gate for obstructions.
2. Force set too low. Adjust FORCE setting until gate completes a full open/close cycle without stop. The force setting may need to be adjusted in cold weather, as the gate will not move freely.
3. Check if the MRT period is too short.

◆ Gate opens but does not close.

1. Photocell (PBS) function is enabled in control board setting but is not equipped (optional). Please cancel the PBS setting (P9 set to 00).
2. Obstruction blocking close photo eyes, Check eyes for alignment and verify all connections and operation for safety devices.
3. Remove the BLUE&GREEN&YELLOW wires of the arm from the control board and use a jumper wire to short the ULT&COM&DLT terminals of the control board which for connecting the three wires and then try it again. The limit switch of the arm is faulty if the arm could run normally.

◆ Gate ignores the limit switches

1. Check that the wires of the limit switch (BLUE&GREEN&YELLOW wires of the arm) are not shorted.
2. Limit switch of the arm is faulty. Replace the limit switch as necessary.

◆ Gate opens, closes or stops on its own

1. Please make sure the P2 setting of the control board is according to the installation of "PULL TO OPEN" or "PUSH TO OPEN".

Quick-Setting Guide

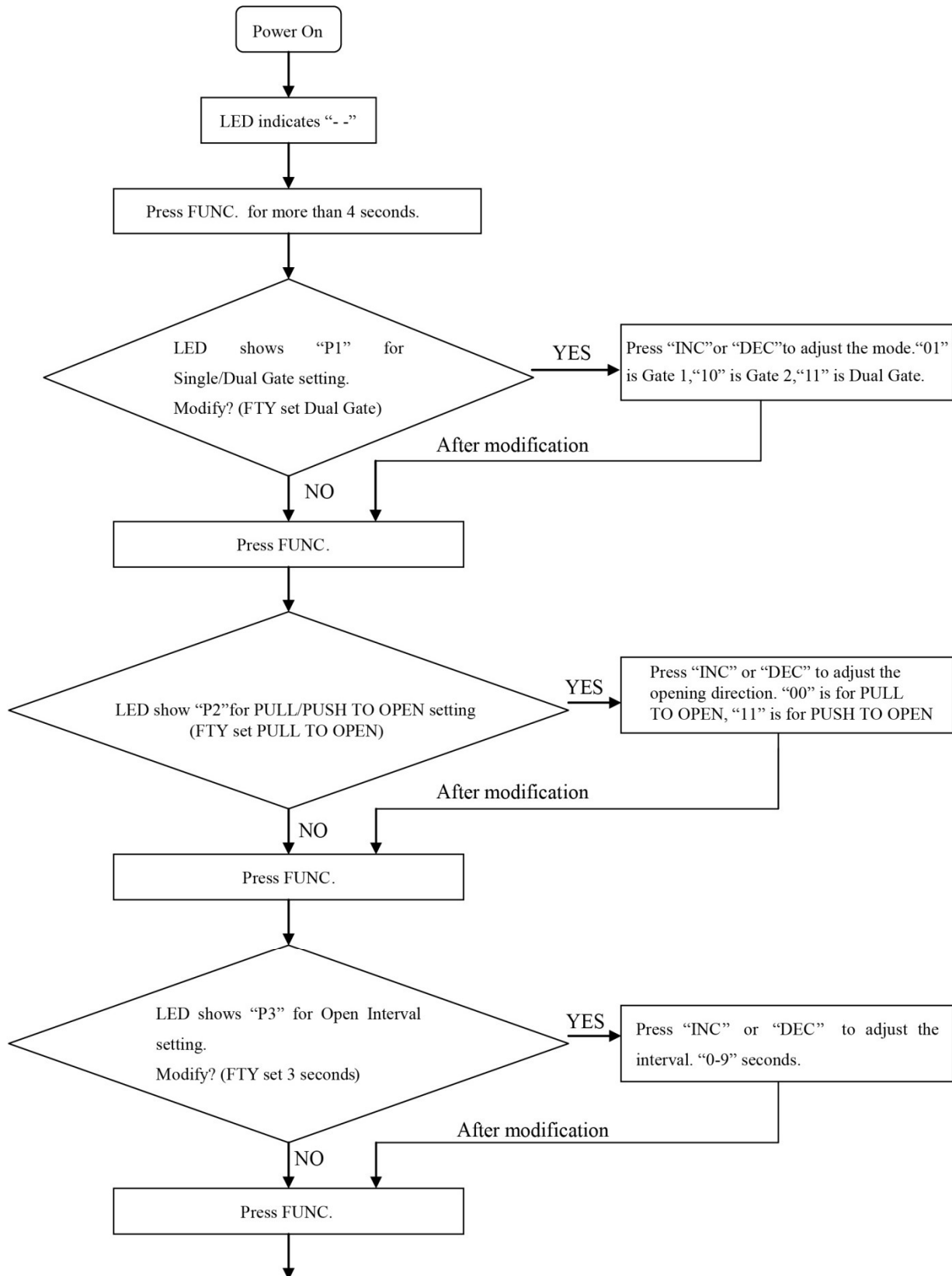

To be continued ...

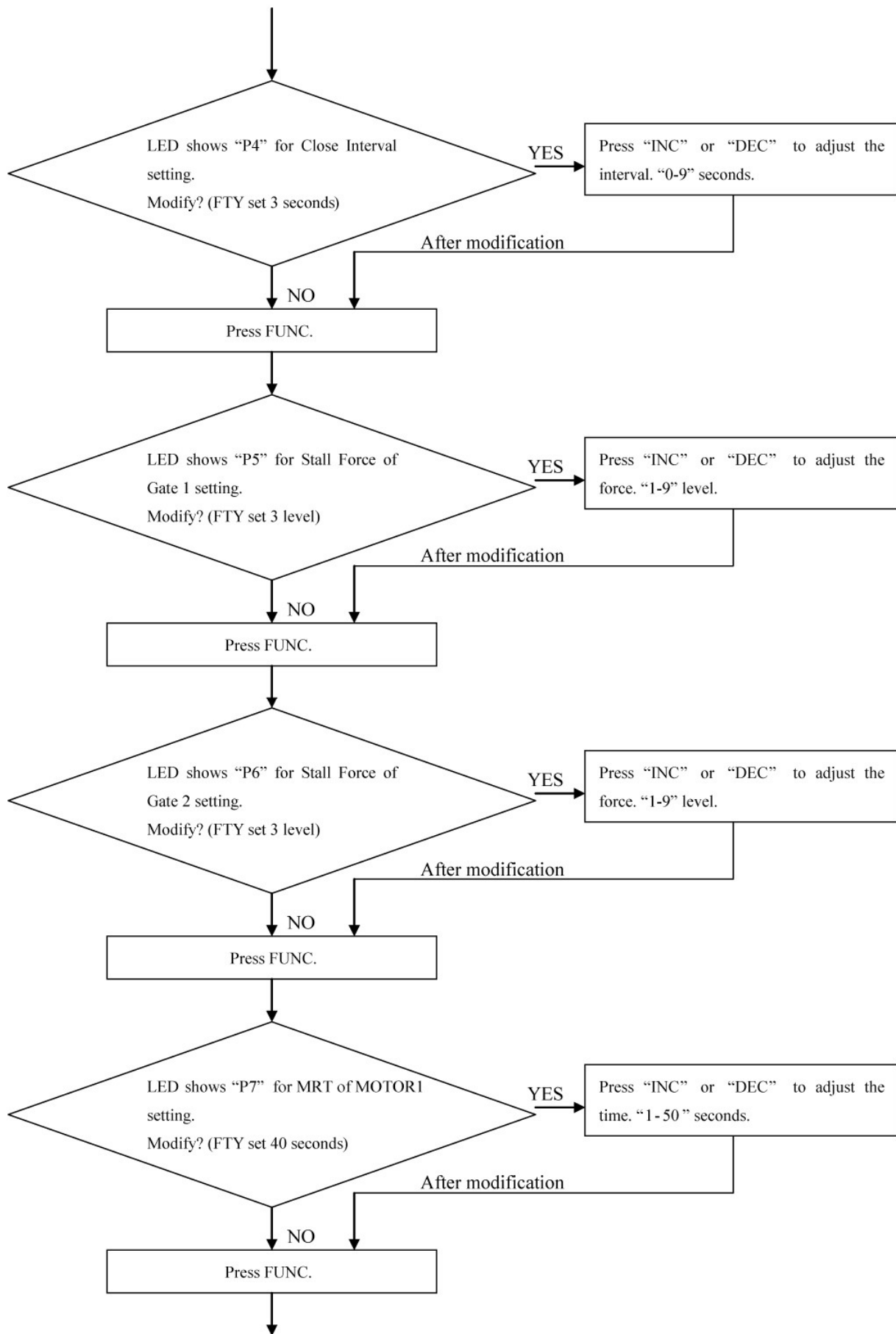

To be continued ...

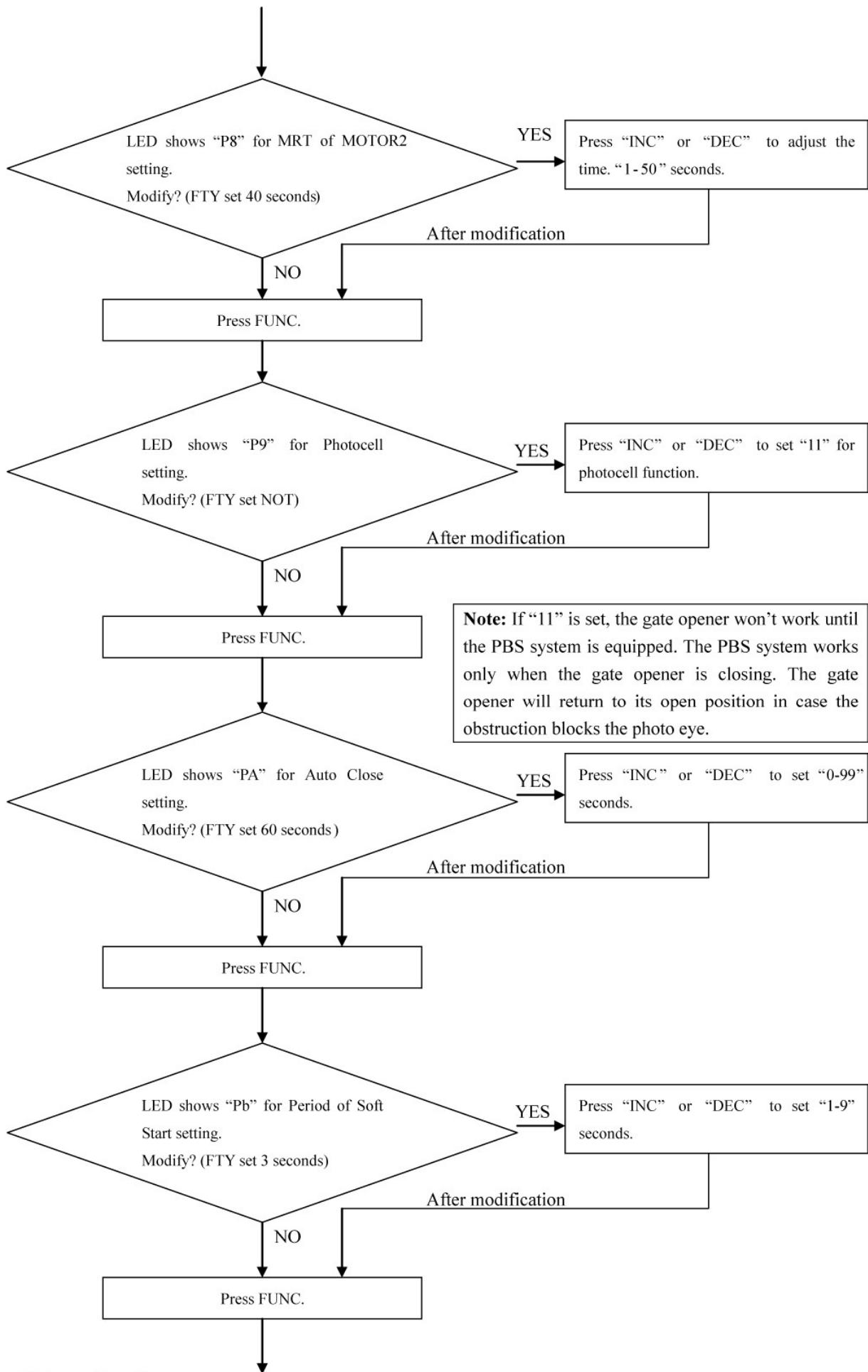

To be continued...

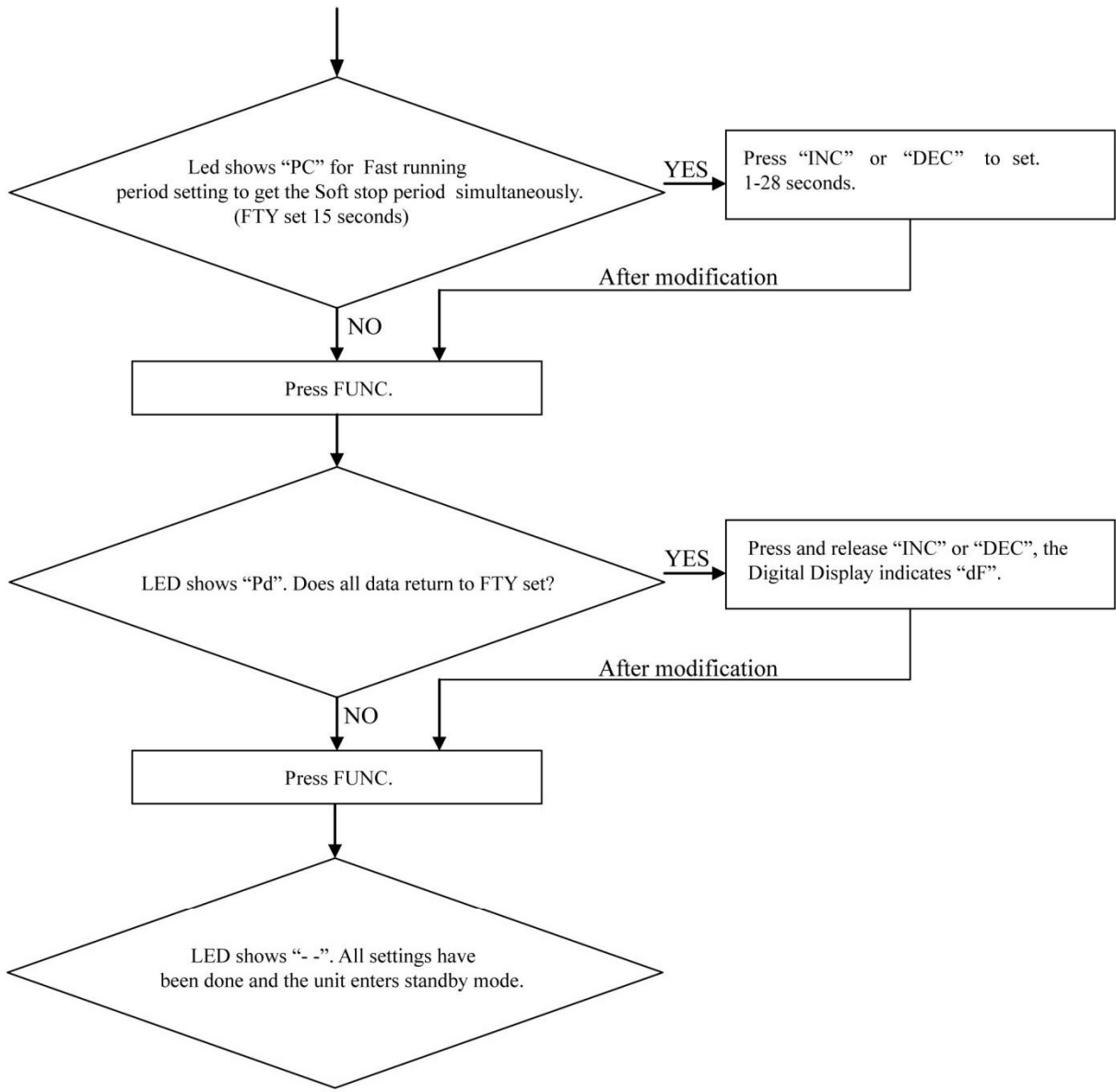

IMPORTANT NOTICE TO USERS:

To maintain the proper working condition of your new automatic gate opener, we recommend that you spray the actuator shaft every 4~6 weeks with silicone. This will keep the actuator working freely and prevent problems.



According to Waste of Electrical and Electronic Equipment (WEEE) directive, WEEE should be separately collected and treated. If at any time in future you need to dispose of this product please do NOT dispose of this product with household waste. Please send this product to WEEE collecting points where available.

Feedback & Review

Your comments and suggestions are important to us
as they help us provide the best possible service.

Should you have any need to contact us, the info below will help you get in touch:



TOPENS Website

www.topens.com

Contact Us:

E-mail: support@topens.com

***Kindly include your Product Model, Purchasing Date & Site, Order #,
and your contact information. All your concerns will be replied within 24 hours.***

Tel: +1 (888) 750 9899 (Toll Free USA & Canada)