



Single Swing Gate Opener

User's Manual

Model:

A3/A5/A8
A3S/A5S/A8S

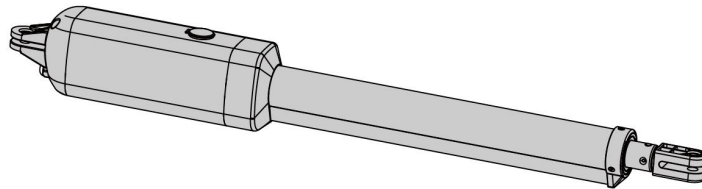

TOPENS Website

www.topens.com

Email: support@topens.com

- ★ Please read and follow all warnings, precautions and instructions before installation and use.
- ★ A 24V 12Ah battery (NOT INCLUDED, 2pcs 12V batteries connected in series may function as 24V), OR the UPS01 AC-DC Power Supply (NOT INCLUDED) is REQUIRED to power up this gate opener. The adapter included in the package is ONLY used to charge the battery.
- ★ Never connect the solar panel to the control board directly to charge the battery.
- ★ Periodic checks of the opener are required to ensure safe operation.
- ★ Save this manual.



CONTACT US:

Visit: www.topens.com

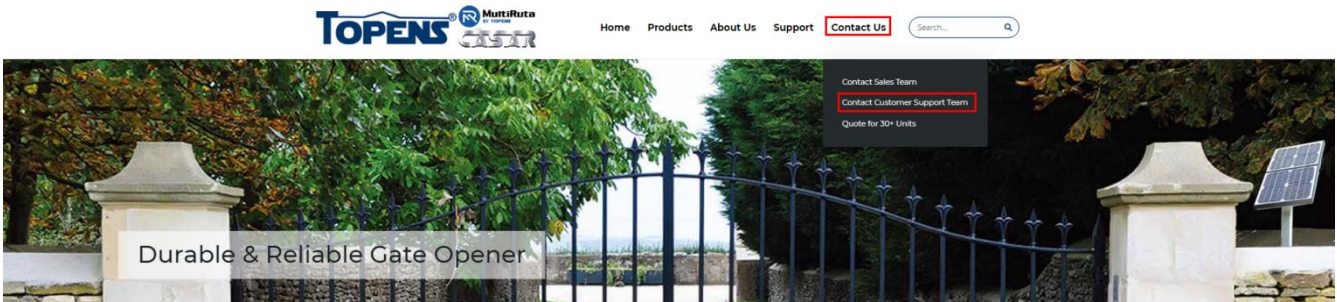

Please record the product model, your email address etc.

in the spaces provided below. Refer to this list when contacting TOPENS for technical service or assistance with your automatic gate opener.

Where did you purchase? (Amazon.com; Amazon.ca: Amazon.co.uk, Amazon.de; Other, Please Specify)

Order#	Product Model	Purchase Date
Full Name	Phone#	Email Address (VERY IMPORTANT)
Street Address, Apartment /Unit, City, State /Province, Zip Code		Country/Region
Approximate Gate Weight (pounds; kg: Other. Please Specify)	Approximate Gate Length (feet; meter; Other. Please Specify)	Did you purchase any accessories? (Please list below)

Issue Details

Email Us: support@topens.com

Call: +1 (888) 750 9899 (Toll Free USA & Canada)

Table of Contents

Safety Installation Information	1
A3 Parts List	3
A5/A8 Parts List	4
Extra Parts for A3/5/8 S	4
Accessories Parts (Included in some models, refers to the actual package)	5
Optional Accessories Parts List (Available at TOPENS Store)	5
Replacement Parts	5
Tools Needed:	6
Technical Specifications & Features	6
Installation Overview	8
Preparation for Installation	8
Install the Opener on the Gate – <i>for Pull to Open</i>	9
Install the Opener on the Gate – <i>for Push to Open</i>	13
Mounting of the Control Box	18
Connection of the Power Supply	18
Connection of the Control Board	23
How to Program the Remote to the Opener	25
How to Erase All the Remote Codes	26
How to Use the Remote to Operate Your Gate Opener	26
Wireless Keypad Programming	26
Adjusting the Limit Switch	27
Setting of the Control Board	28
Maintenance	29
Trouble Shooting	30

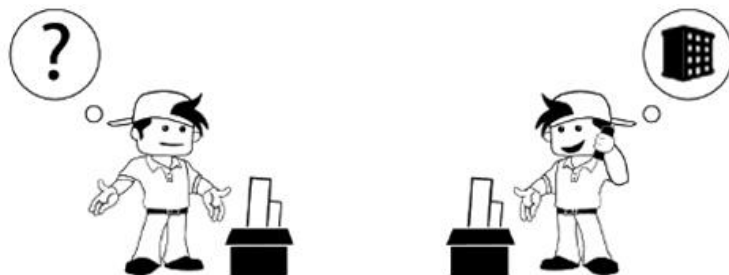

■ Ask for TOPENS help by E-mail or phone anytime.

Safety Installation Information

1. READ and FOLLOW all instruction.
2. The gate opener is intended for use with Class I vehicular swing gates.

Class I denotes a vehicular gate opener (or system) dwellings, or a garage or parking area associated therewith.

Install the gate opener only when the opener is appropriate for the construction and the usage class of the gate.

3. Gate opening system designers, installers and users must take into account the possible hazards associated with each individual application. Improperly designed, installed or maintained systems can create risks for the user as well as the bystander. Gate system design and installation must reduce public exposure to potential hazards. All exposed pinch points must be eliminated or guarded.

4. A gate opener can create high levels of force during normal operation. Therefore, safety features must be incorporated into every installation. Specific safety features include safety sensors.

5. The gate must be properly installed and work freely in both directions prior to the installation of the gate opener.

6. The gate must be installed in a location so that enough clearance is provided between the gate and adjacent structure when opening and closing to reduce the risk of entrapment. Swinging gates shall not open into public access areas.

7. The opener is intended for use only on gates used for vehicles. Pedestrians must be supplied with a separate access opening. The pedestrian access opening shall be designed to promote pedestrian usage. The pedestrian access shall be located such that persons will not come in contact with the moving vehicular gate.

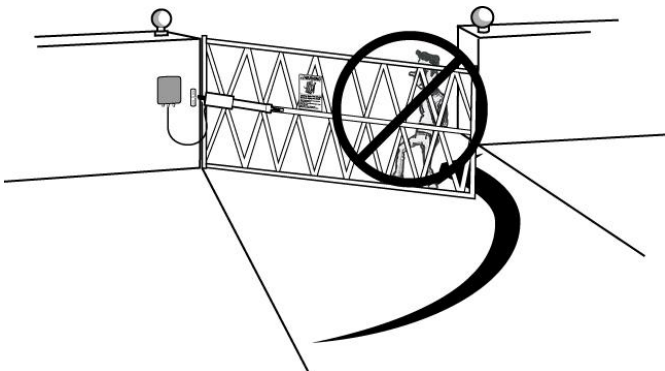

8. Pedestrians should never cross the pathway of a moving gate. The gate opener is not acceptable for

use on any pedestrian gate. Pedestrians must be supplied with a separate pedestrian access.

9. For an installation utilizing non-contact sensors (safety sensors), see product manual on the placement of non-contact sensors (safety sensors) for each type of application.

a. Care shall be exercised to reduce the risk of nuisance tripping, such as when a vehicle trips the safety sensor while the gate is still moving.

b. One or more non-contact sensors (safety sensors) shall be located where the risk of entrapment of obstruction exists, such as the perimeter reachable by a moving gate or barrier.

10. Never mount any device that operates the gate opener where the user can reach over, under, around or through the gate to operate the controls. Controls are to be placed at least 6' (1.8m) from any part of the moving gate.

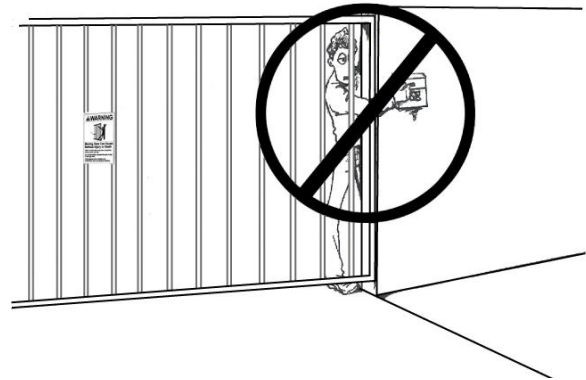

11. Controls intended to be used to reset an operator after 2 sequential activations of the entrapment protection device or devices must be located in the line of sight of the gate, or easily accessible controls shall have a security feature to prevent unauthorized use. Never allow anyone to hang on or ride the gate during the entire travel of the gate.

12. Each gate opener is provided with two safety warning placards. The placards are to be installed on the front and back of the gate where they are plainly visible. The placards may be mounted using cable ties through the four holes provided on each placard.

All warning signs and placards must be installed where visible in the area of the gate.

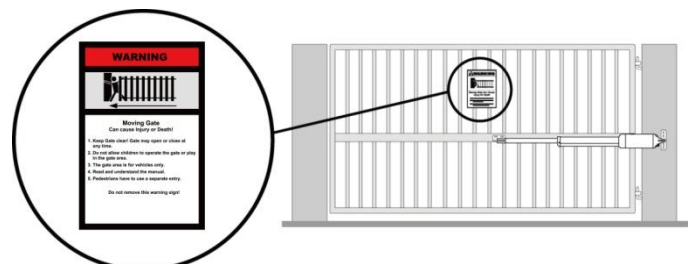

13. To AVOID damaging gas, power, or other underground utility lines, contact underground utility locating companies BEFORE digging.

14. Do not permit children to play on or around the gate and keep all controls out of their reach.

NOTE:

TOPENS Gate Operator can be used for driveway gates made by steel, wood, vinyl, and shaped as panel, tube, and chain-link. While use on solid surface gates is NOT recommended. Solid surface gates have a high resistance to the wind. *If the wind is strong enough, the operator will obstruct and stop.*

CHECK YOUR GATE

Gate MUST be level. Gate and gate post MUST be plumb. Gate MUST have a smooth bottom edge, no protrusions should exist.







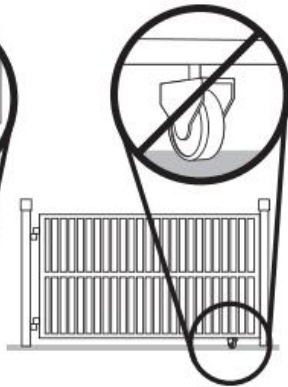
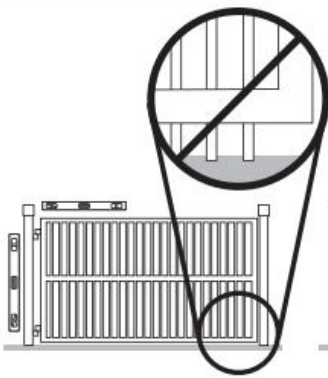













Remove ANY/ALL wheels from the bottom of gate.

Gate MUST NOT hit or drag across ground.























Gate MUST swing freely and be supported entirely by its hinges.



A3 Parts List

 <p><A3> Gate Opener Actuator (1 pc)</p>		 <p>Release Key (1 pc)</p>	
 <p>Control Box (1 pc)</p>	 <p>CE Remote Control (1 pc)</p>		 <p>Warning Signs (2 pcs)</p>
	 <p>PSO Part (1 pc)</p>		
 <p>Adapter (1 pc)</p>	 <p>Post Bracket (1 pc)</p>	 <p>Post Pivot Bracket (1 pc)</p>	 <p>Gate Bracket (1 pc)</p>
<h3>Hardware</h3>			
 <p>Φ10 Washer (5 pcs)</p>	 <p>M10×200 Bolt (2 pcs)</p>		
 <p>Φ10 Lock Washer (5 pcs)</p>	 <p>M10×75 Bolt (2 pcs)</p>		
 <p>Φ8 Washer (1 pc)</p>	 <p>M10×35 Bolt (1 pc)</p>		
 <p>M10 Nut (5 pcs)</p>	 <p>M8×30 Bolt (1 pc)</p>		
 <p>M8 Nut (1 pc)</p>	 <p>12×40 Clevis Pin (1 pc)</p>		
 <p>Hairpin Clip (2 pcs)</p>	 <p>12×30 Clevis Pin (1 pc)</p>		

A5/A8 Parts List

 <p><A5/A8> Gate Opener Actuator (1 pc)</p>		 <p>Release Key (1 pc)</p>	
 <p>Control Box (1 pc)</p>	 <p>CE Remote Control (1pc for A5 / 2pcs for A8)</p>		 <p>Warning Signs (2 pcs)</p>
	 <p>PSO Part (1 pc)</p>		
 <p>Adapter (1 pc)</p>	 <p>Post Bracket (2 pcs)</p>	 <p>Post Pivot Bracket (1 pc)</p>	 <p>Gate Bracket (1 pc)</p>
Hardware			
 <p>Φ10 Washer (7 pcs)</p>	 <p>M10×200 Bolt (4 pcs)</p>		
 <p>Φ10 Lock Washer (7 pcs)</p>	 <p>M10×75 Bolt (2 pcs)</p>		
 <p>Φ8 Washer (1 pc)</p>	 <p>M10×35 Bolt (1 pc)</p>		
 <p>M10 Nut (7 pcs)</p>	 <p>M8×30 Bolt (1 pc)</p>		
 <p>M8 Nut (1 pc)</p>	 <p>12×40 Clevis Pin (1 pc)</p>		
 <p>Hairpin Clip (2 pcs)</p>	 <p>12×30 Clevis Pin (1 pc)</p>		

Extra Parts for A3/5/8 S

 <p>10W Solar Panel (2 pcs)</p>	 <p>TCS3 Solar Charge Controller (1 pc)</p>
--	--







Accessories Parts (Included in some models, refers to the actual package)

 <p>JD24VY 24V Warning Light</p>	 <p>TC102 Photo Eye Beam Sensor</p>
---	--

Optional Accessories Parts List (Available at TOPENS Store)

 <p>M12 Remote Control</p>	 <p>ERM12 External Receiver</p>	 <p>TC186-R WiFi Smartphone Remote Control with Camera</p>	 <p>TC188 Universal Wireless and Wired Keypad</p>
 <p>TKP3 Wireless Keypad</p>	 <p>TC175P Wired Keypad</p>	 <p>TEW3 Vehicle Sensor Exit Wand</p>	 <p>HLR01 HomeLink Remote Control Kit</p>
 <p>TC173 Wireless Push Button</p>	 <p>TC147 Wall Push Button</p>	 <p>TC148 Waterproof Wall Push Button</p>	 <p>TRF3 Reflection Photocell Sensor</p>
 <p>TC102 Photo Eye Beam Sensor</p>	 <p>JD24VY 24V Warning Light</p>	 <p>TSP30W 30W Solar Panel Charging Kit</p>	 <p>TSQ20W 20W Solar Panel Kit</p>
 <p>TCS3 Solar Charge Controller</p>	 <p>UPS01 Uninterrupted Power Supply</p>	 <p>DPS180-U AC-DC Power Supply</p>	 <p>25FT Extension 5 Conductor Cable</p>
 <p>ET24 Electric Gate Lock</p>			

Replacement Parts

 <p>EKP MJ2B Control Board for A3/ A3S Gate Opener</p>	 <p>EKP MJ1B Control Board for A5/ A5S/ A8/ A8S Gate Opener</p>	 <p>ALS01 Limit Switch</p>	 <p>A3JB/ A5JB/ A8JB Arm Actuator</p>
 <p>TS24-U Adapter</p>	 <p>MK01 Hardware Kit</p>		

WARNING: Changes or modifications not expressly specified by this user manual, TOPENS could void the warranty of this equipment.

Tools Needed:

- Power Drill
- Tape Measure
- Open End Wrenches - 14# & 17# or Adjustable Wrenches
- Wire Strippers
- C-Clamps - small, medium, and large
- Level
- Hacksaw or Heavy Duty Bolt Cutters
- Phillips Screwdriver

Technical Specifications & Features

Specifications			
	A3(S)	A5(S)	A8(S)
Input:	Adapter Input: 100-240V~ 50/60Hz		
Motor voltage:	24VDC		
Power:	30W	50W	80W
Current:	1.5A	2A	3A
Actuator speed:	16mm/s (0.6 in/s)		
Max. actuator travel:	385mm (15.2 in)		
Ambient Temperature:	-20°C ~ +50°C (0°F to 120°F)		
Protection class:	IP44		

Gate Capacity of A3(S)

Gate Weight	140kg (300lbs)	✓	NR	NR	NR	NR
	110kg (250lbs)	✓	✓	NR	NR	NR
	90kg (200lbs)	✓	✓	✓	NR	NR
	70kg (150lbs)	✓	✓	✓	✓	NR
	50kg (100lbs)	✓	✓	✓	✓	✓
		1.2m (4')	1.8m (6')	2.4m (8')	3m (10')	3.6m (12')
Gate Length						

NOTE: "NR" indicates this size and weight combination is NOT recommended for one arm actuator.
NOTE: Ball bearing hinges should be used on all gates weighing over 140kg (300 lbs).

Gate Capacity of A5(S)

Gate Weight	250kg (550lbs)	✓	NR	NR	NR	NR	NR
	200kg (450lbs)	✓	✓	NR	NR	NR	NR
	160kg (350lbs)	✓	✓	✓	NR	NR	NR
	110kg (250lbs)	✓	✓	✓	✓	NR	NR
	70kg (150lbs)	✓	✓	✓	✓	✓	NR
	50kg (100lbs)	✓	✓	✓	✓	✓	✓
		1.2-1.8m(4'-6')	2.4m (8')	3m (10')	3.6m (12')	4.3m (14')	5m (16')
Gate Length							

Gate Capacity of A8(S)

Gate Weight	400kg (880lbs)	✓	NR	NR	NR	NR	NR	NR
	350kg (770lbs)	✓	✓	NR	NR	NR	NR	NR
	300kg (650lbs)	✓	✓	✓	NR	NR	NR	NR
	250kg (550lbs)	✓	✓	✓	✓	NR	NR	NR
	200kg (450lbs)	✓	✓	✓	✓	✓	NR	NR
	160kg (350lbs)	✓	✓	✓	✓	✓	✓	NR
	110kg (250lbs)	✓	✓	✓	✓	✓	✓	✓
		1.2-1.8m(4'-6')	2.4m (8')	3m (10')	3.6m (12')	4.3m (14')	5m (16')	5.5m (18')
Gate Length								

These specifications are subject to change without notice.

Features:

- Soft start and soft stop
- Emergency release key in case of power failure
- Fast selecting push/pull to open
- Stop in case of obstruction during gate opening.
- Reverse in case of obstruction during gate closing.
- Built in adjustable auto-close (3-120 seconds)
- Built in max. Motor running time (MRT) for multiple safety protection (40 seconds)
- Reliable electromagnetism limit for easy adjustment
- Can be equipped with a wide range of accessories
- Easy to install, and minimum maintenance requirement

Installation Overview

Pull-to-Open Gate

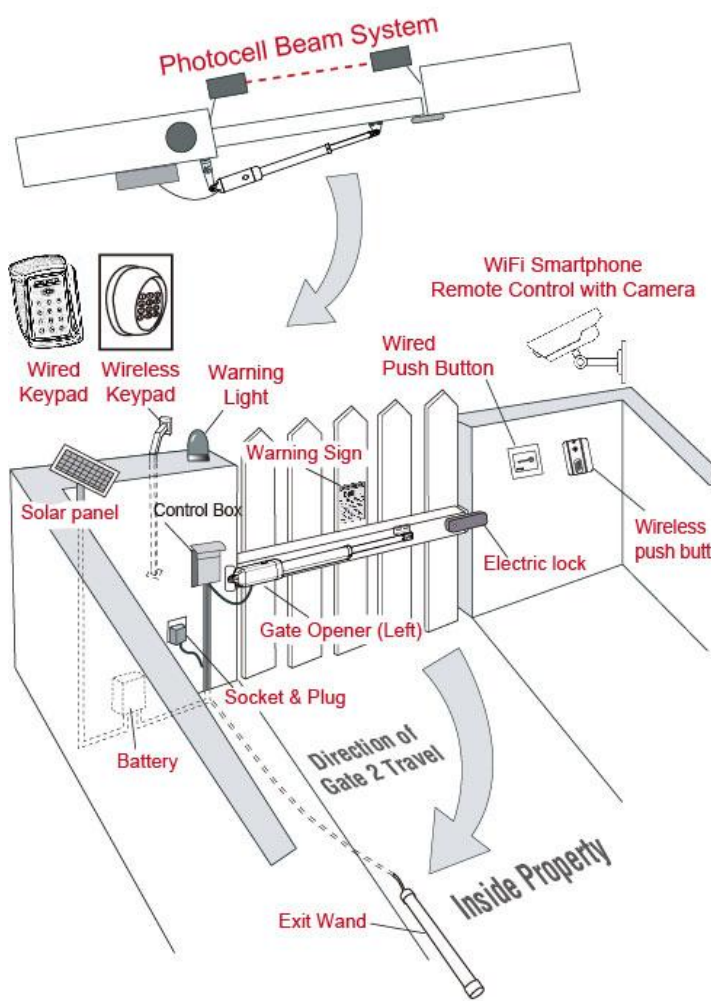

Left-Hand Gate

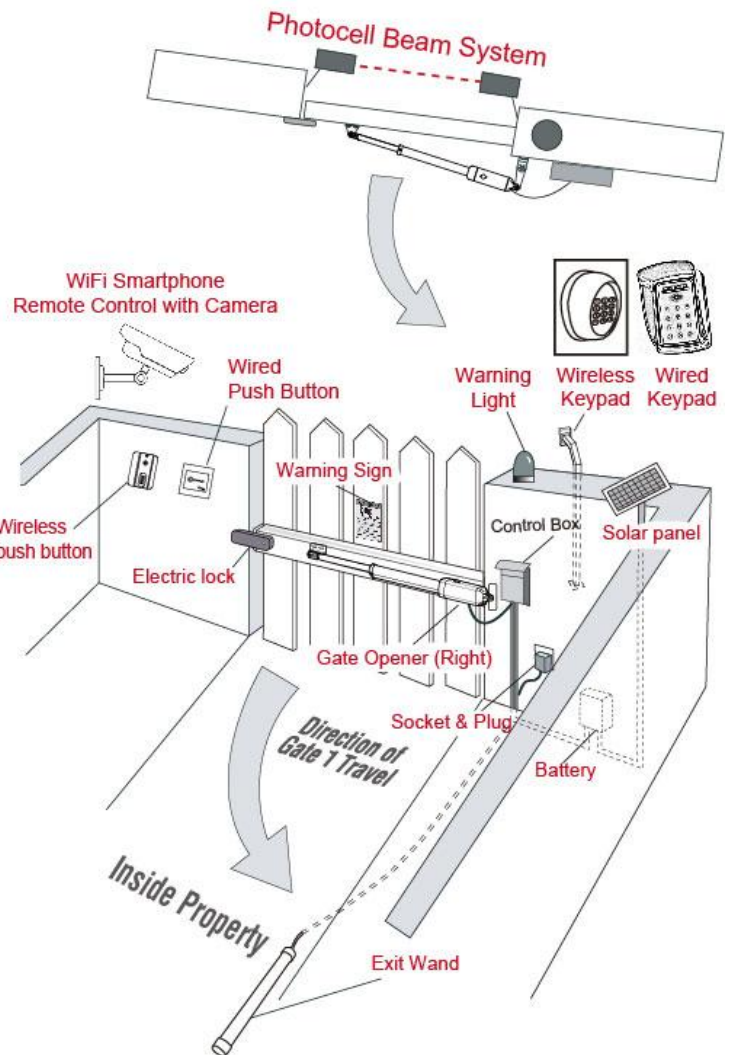

Right-Hand Gate

Preparation for Installation

There are two installation types for the gate opener, **Pull-to-Open** and **Push-to-Open**.

In the **Push-to-Open** installation, gate opens out from the property. A Push-To-Open Bracket (**PSO part**) is required to be used for each gate.

NOTE: Ensure the gate does not open into public areas. One more person will help when installing.

The gate opener is mounted to the gate and to the gate post. Both round and square posts can be used because the Post Brackets are curved. When mounting the Post Brackets, use bolts long enough to pass through the entire post. M10 x 200 bolts are included. Concrete anchors are not provided.

When mounting the Post Brackets to wooden posts, a larger-size washer or metal plate should be used between the bolts and the wooden post to ensure the stability of the fastening hardware. If the post is smaller than 6" diameter or square, it should be made of metal and set in cement to ensure its stability.

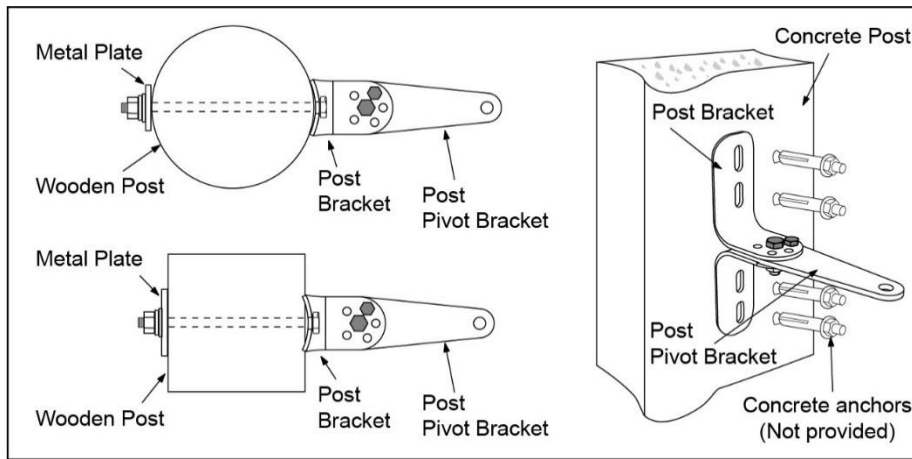

Install the Opener on the Gate – for Pull to Open

The position of Post Bracket is very important. The following illustrations and tables are required to determine the proper mounting position for the Post Bracket. The tables show the maximum opening angle of the gate for a given A and B. For example, if A is 16cm and B is 14cm, the maximum opening angle of the gate is 110°

Pull-to-Open Installation — Gate in Closed position (Moving-Rod is extended)

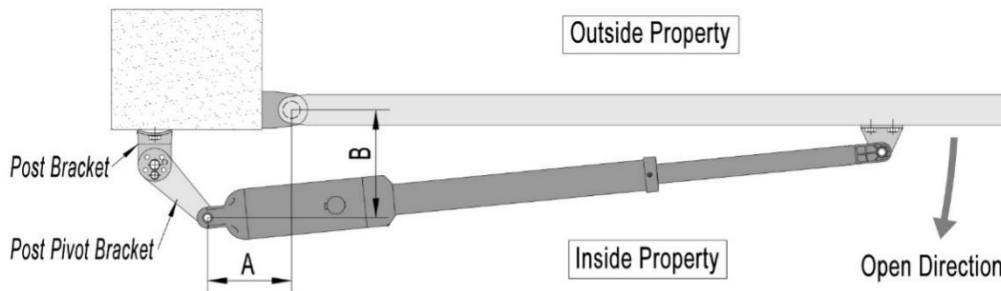

	A=10cm	A=12cm	A=14cm	A=16cm	A=18cm	A=20cm	A=22cm	A=24cm	A=26cm
B=10cm	90°	99°	106°	116°	118°	120°	111°	104°	100°
B=12cm	90°	98°	105°	113°	116°	112°	105°	99°	95°
B=14cm	90°	97°	104°	110°	111°	105°	99°	94°	91°
B=16cm	90°	96°	103°	109°	103°	99°	94°	90°	87°
B=18cm	90°	95°	101°	103°	96°	93°	89°	86°	83°
B=20cm	90°	95°	99°	95°	90°	87°	84°	81°	79°
B=22cm	90°	94°	95°	88°	84°	82°	80°	78°	76°
B=24cm	90°	93°	87°	82°	79°	78°	76°	74°	73°
B=26cm	90°	87°	81°	77°	75°	73°	72°	71°	70°
B=28cm	84°	79°	75°	73°	71°	69°	69°	68°	68°

1. Insert the bolts through the holes of post bracket and post pivot bracket as shown. Place washers and nuts on the bottom of the bolts and hand tighten.

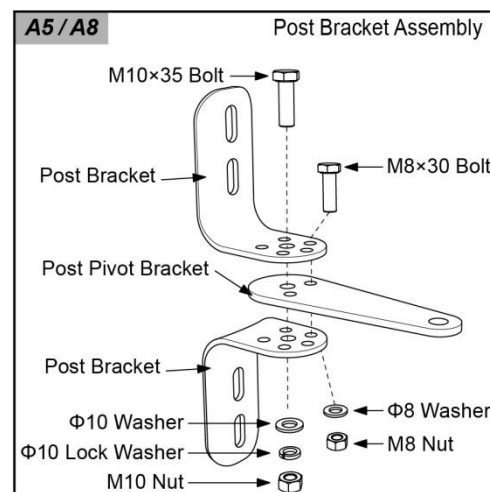
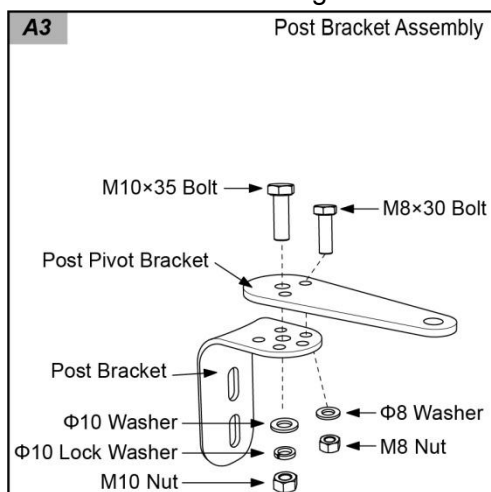

2. Attach the gate bracket and post bracket assy. to the opener by inserting a clevis pin. Secure the clevis pins using the hairpin clips.

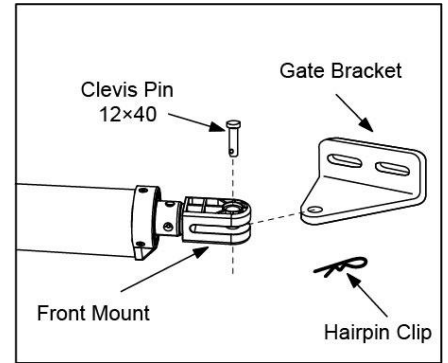
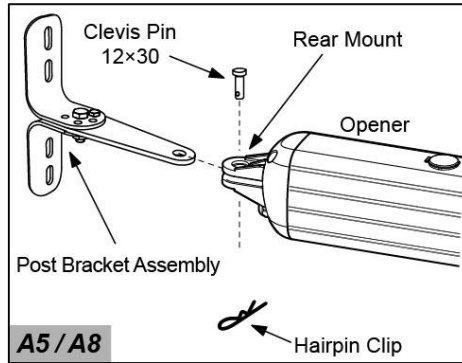
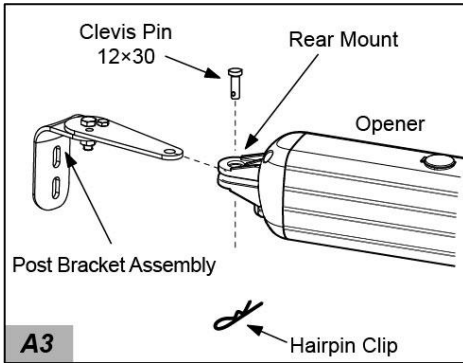

3. Open the release hole plug on the top of the gate opener, insert the release key, and turn the key 90° clockwise. This releases the motor and allows the push-pull rod to be manually extended and retracted. To restore normal operation, turn the key 90° counterclockwise.

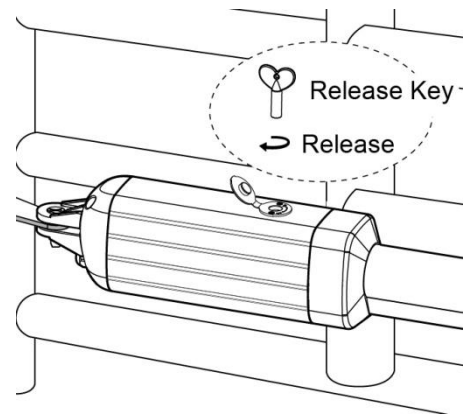

4. With the opener fully retracted and with the gate in the fully open position (for Pull-to-Open installation), place the opener with the Post Bracket Assy. and Gate Bracket on the gate post and the gate. While holding the gate opener in the level position, temporarily secure it with two C-clamps.

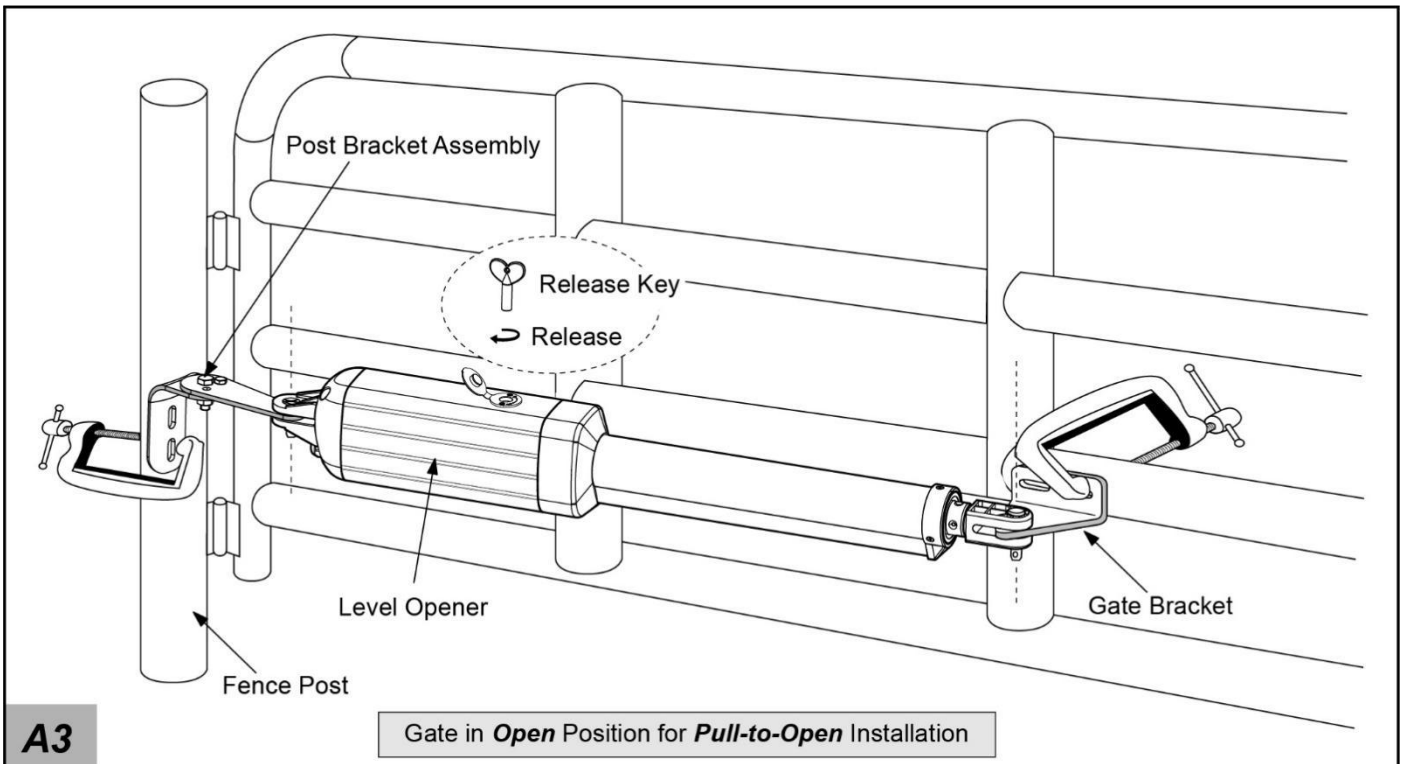

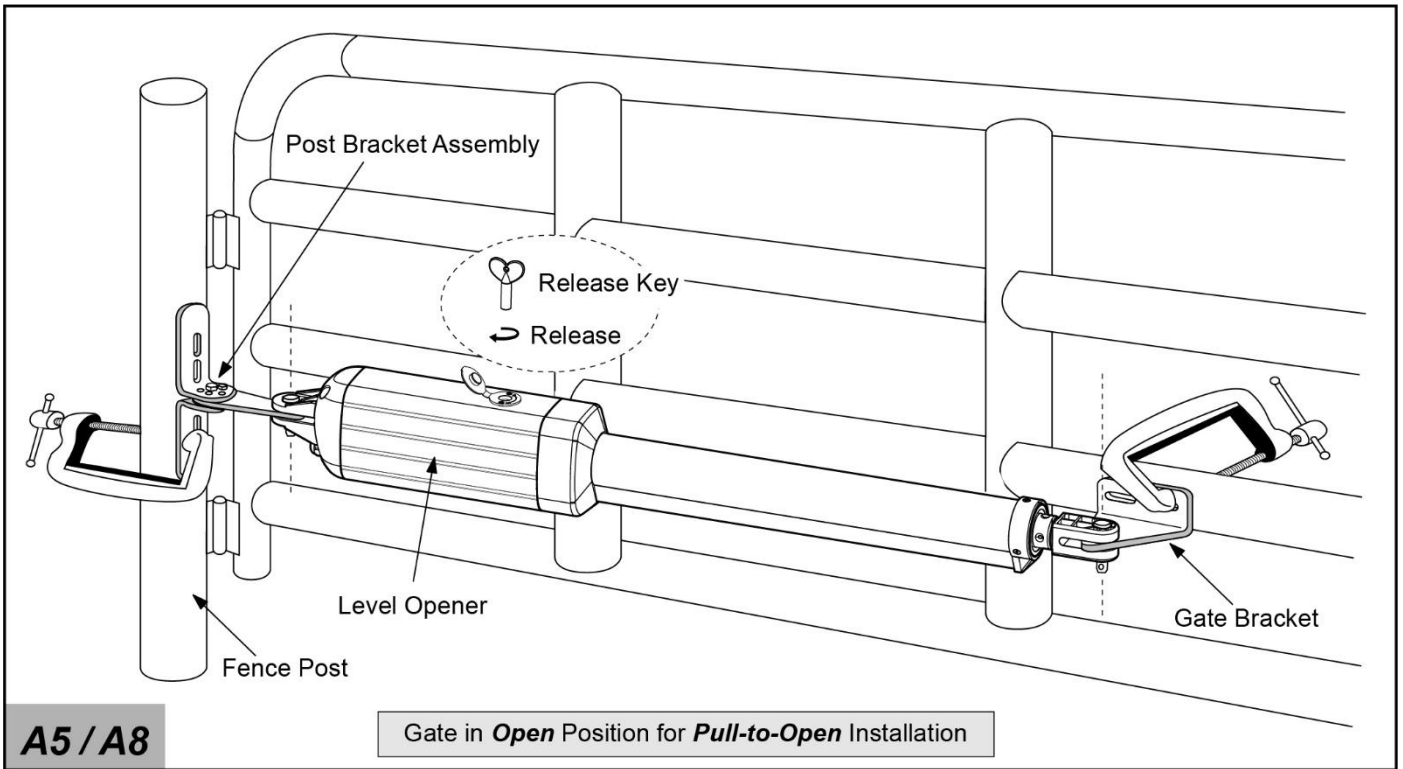

5. Make sure that there is a minimum clearance of 2.5cm between the gate and the opener and that the opener and the Post Pivot Bracket are not binding in both the gate-open and gate-closed positions. If there is not at least 2.5cm of clearance or if the opener and the Post Pivot Bracket are binding, rotate the Post Pivot Bracket and/or move the Post Bracket Assy. to obtain the minimum clearance and eliminate the binding.

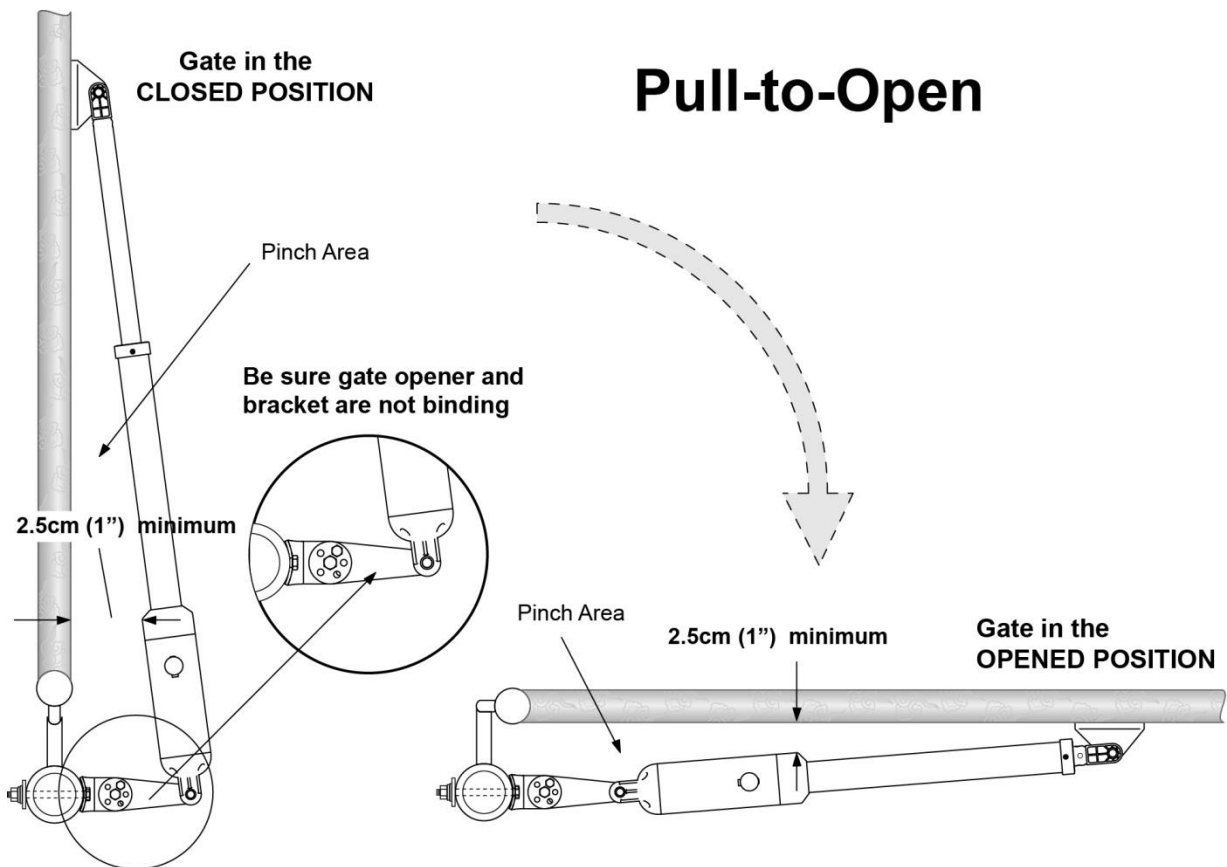

6. Sign the bolt-hole point on the gate post and gate. Do this by placing a punch or a sign in the middle of each bolt slot on the post bracket and the gate bracket. It allows slight adjustments to the post bracket. Then remove the opener and brackets assy. by taking off the C-clamps.

7. Drill 10.5 mm diameter holes through the post and the gate at the marked locations.

8. Attach the post bracket assemblies to

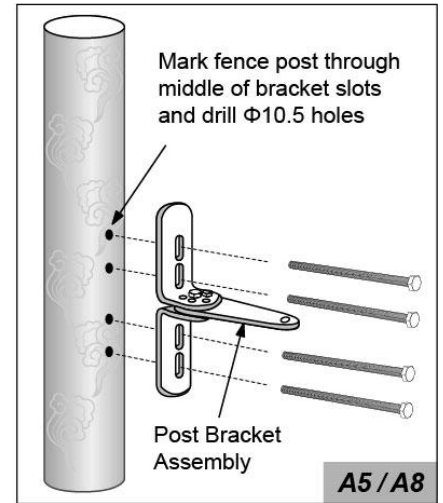
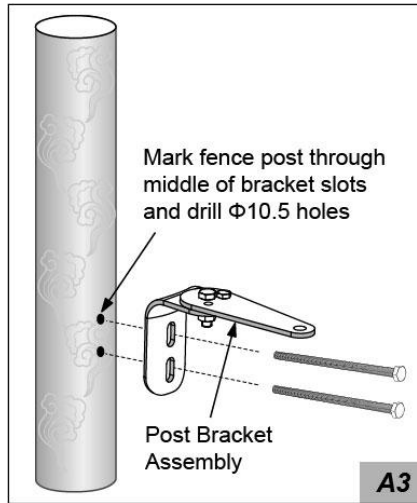

the gate post by inserting M10 x 200 bolts through each post bracket assy. and the drilled holes in the gate post. Fasten each bolt with one \varnothing 10 washer, one \varnothing 10 lock washer, and one \varnothing 10 nut.

9. Attach the gate brackets to each gate by inserting two M10 x 75 bolts through the gate brackets and the drilled holes in the gates. Fasten each bolt with one \varnothing 10 lock washer, and one \varnothing 10 nut.

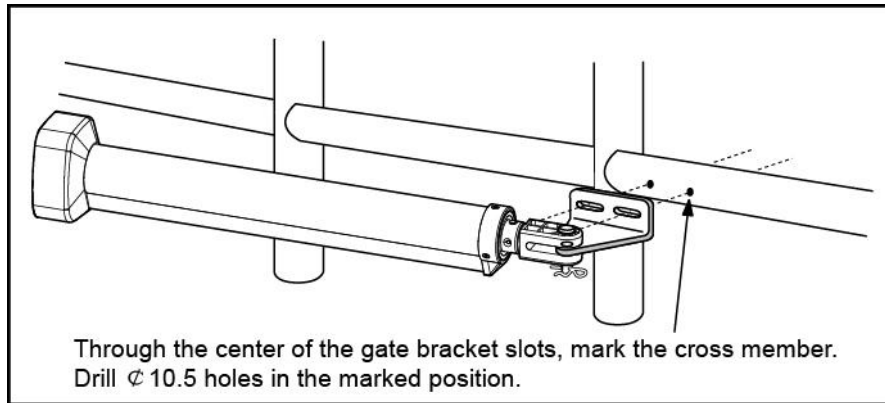

10. Cut off any part of the bolts that extend beyond the tightened nuts.

11. With the opener fully retracted and with the gate in the fully open position (for Pull-to-Open installation), insert a clevis pin through the gate opener and the Post Pivot Bracket and insert another clevis pin through the gate opener and the Gate Bracket. Secure each clevis pin with a hairpin clip.

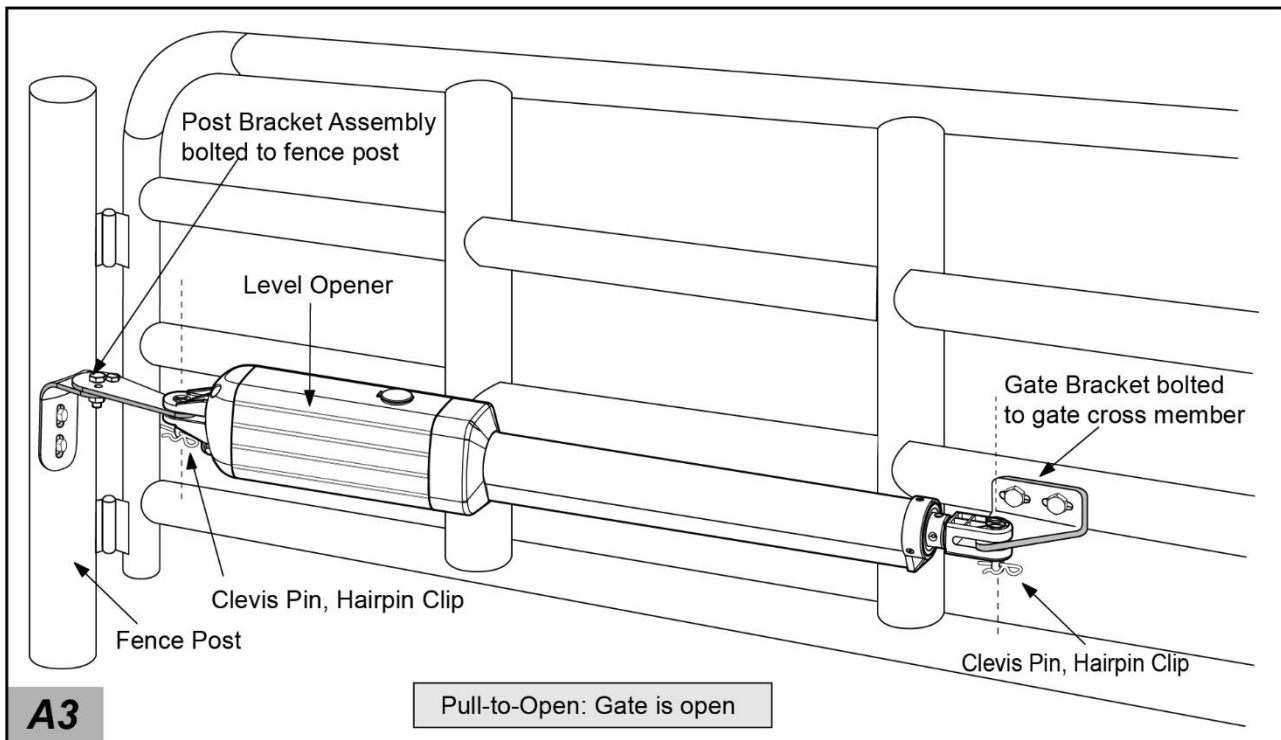

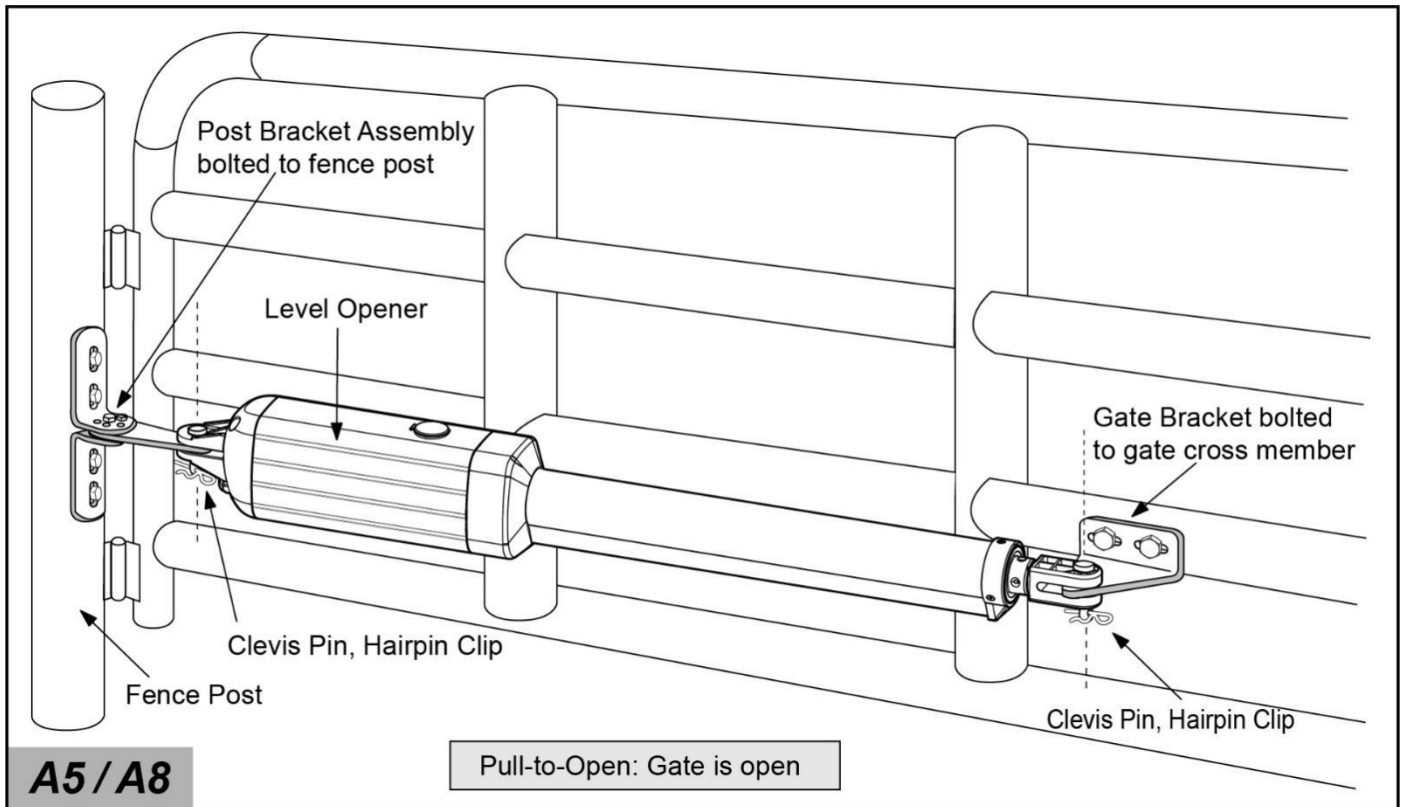

12. Open the release hole plug on the top of the gate opener, insert the release key, and turn the key 90° counterclockwise. This restores normal operation.

NOTE: The setting of the PULL/PUSH TO OPEN of the control board should be in accordance with the installation.

Install the Opener on the Gate – for Push to Open

The position of Post Bracket is very important. The following illustrations and tables are required to determine the proper mounting position for the Post Bracket. The tables show the maximum opening angle of the gate for a given A and B. For example, if A is 15cm and B is 12cm, the maximum opening angle of the gate is 110°

Push-to-Open Installation — Gate in Closed position (Moving-Rod is retracted)

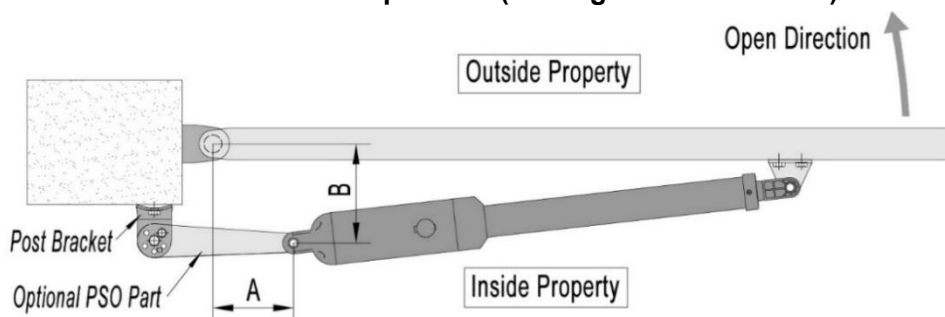

	A=15cm	A=13cm	A=11cm	A=9cm
B=10cm	112°	105°	95°	86°
B=12cm	110°	103°	95°	86°
B=14cm	107°	101°	95°	86°
B=16cm	105°	100°	94°	86°
B=18cm	104°	99°	93°	86°
B=20cm	103°	98°	93°	86°
B=22cm	103°	97°	92°	87°
B=24cm	95°	97°	92°	87°
B=26cm	88°	96°	92°	87°
B=28cm	82°	91°	91°	87°

1. Insert the bolts through the holes of post bracket and **PSO part (push to open bracket)** as shown. Place washers and nuts on the bottom of the bolts and hand tighten.

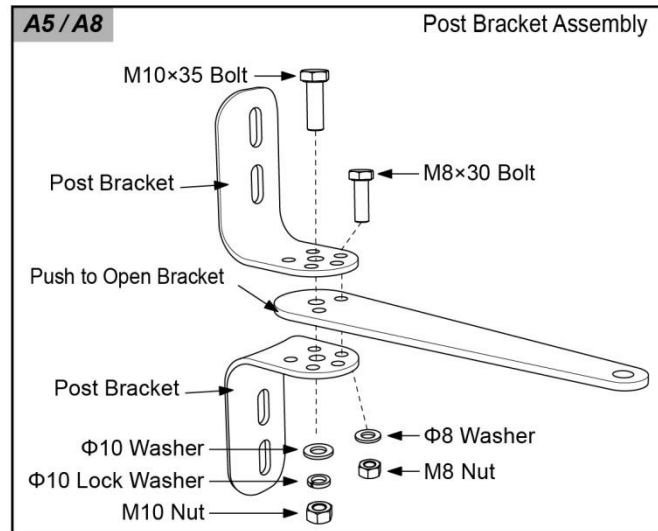
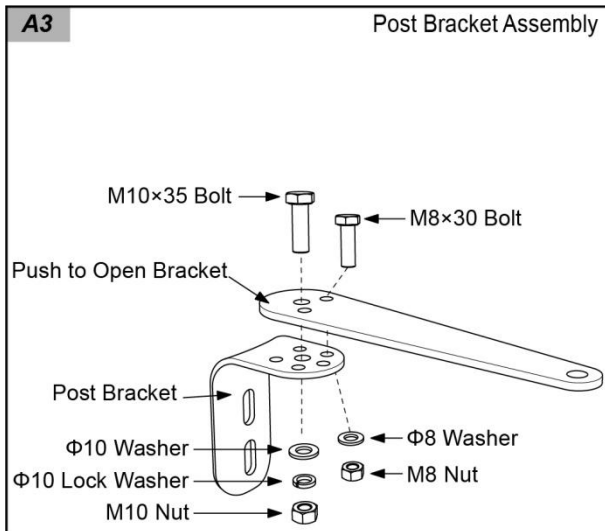

2. Attach the gate bracket and post bracket assy. to the opener by inserting a clevis pin. Secure the clevis pins using the hairpin clips.

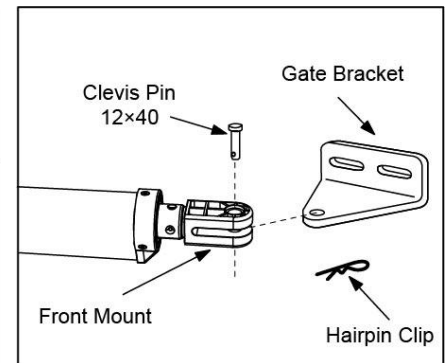
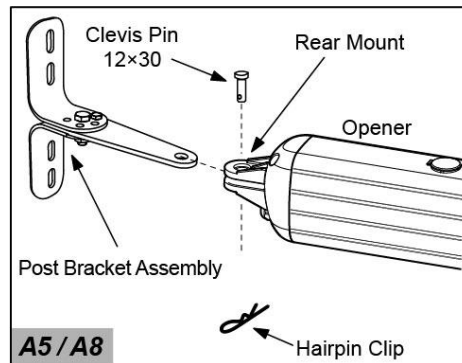
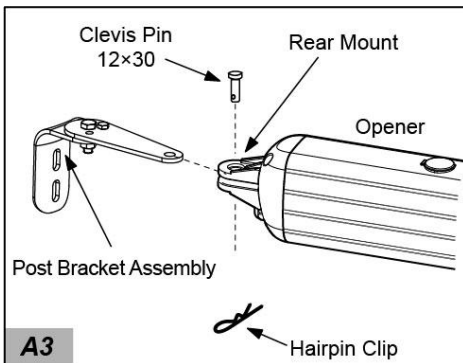

3. Open the release hole plug on the top of the gate opener, insert the release key, and turn the key 90° clockwise. This releases the motor and allows the push-pull rod to be manually extended and retracted. To restore normal operation, turn the key 90° counterclockwise.

4. With the opener fully retracted and with the gate in the fully closed position (for Push-to-Open installation), place the opener with the Post Bracket Assy. and Gate Bracket on the gate post and the gate. While holding the gate opener in the level position, temporarily secure it with two C-clamps.

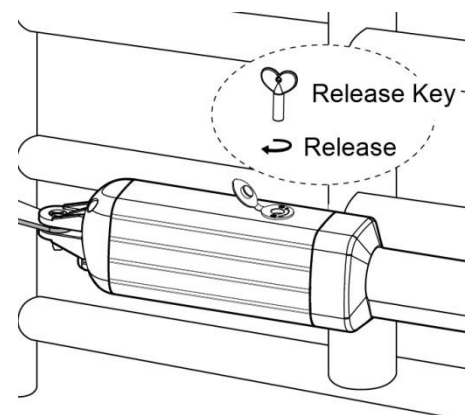

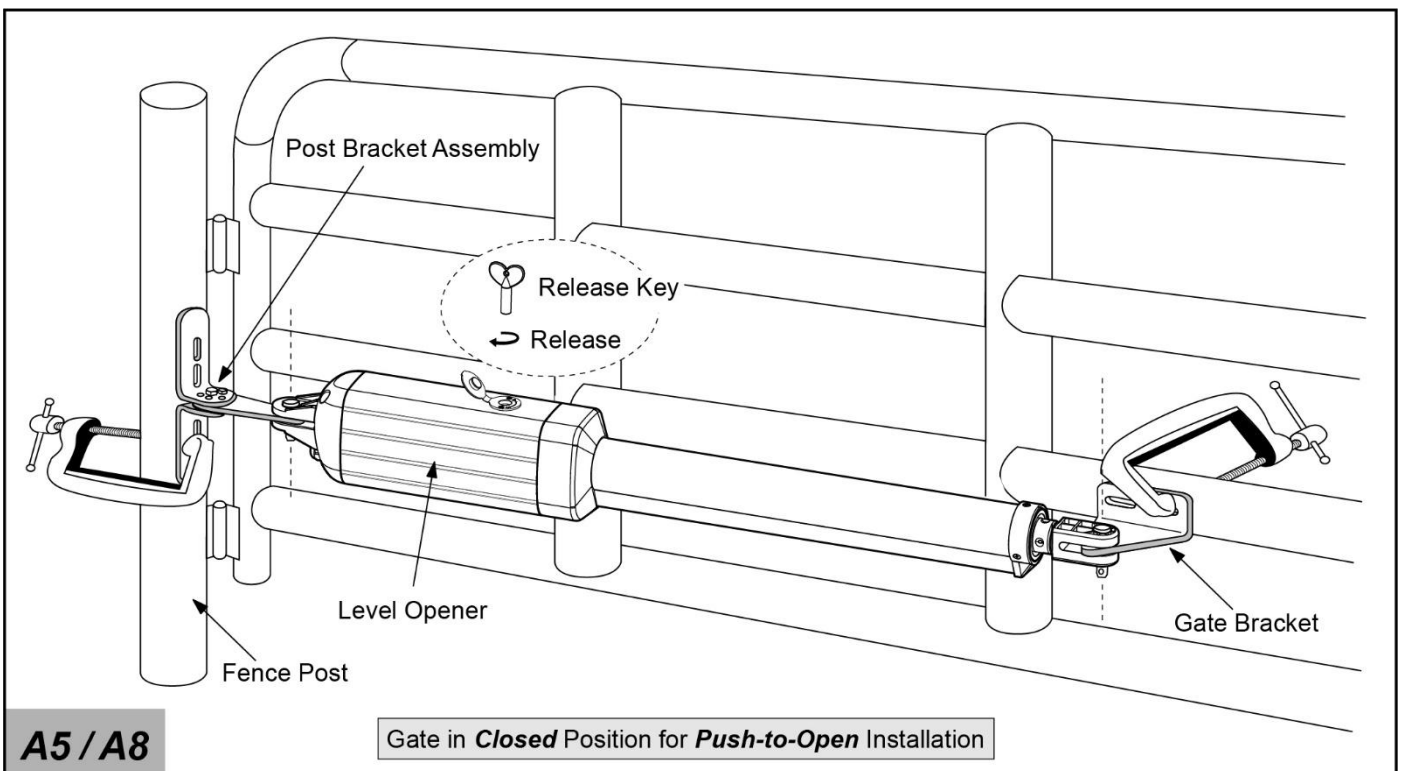
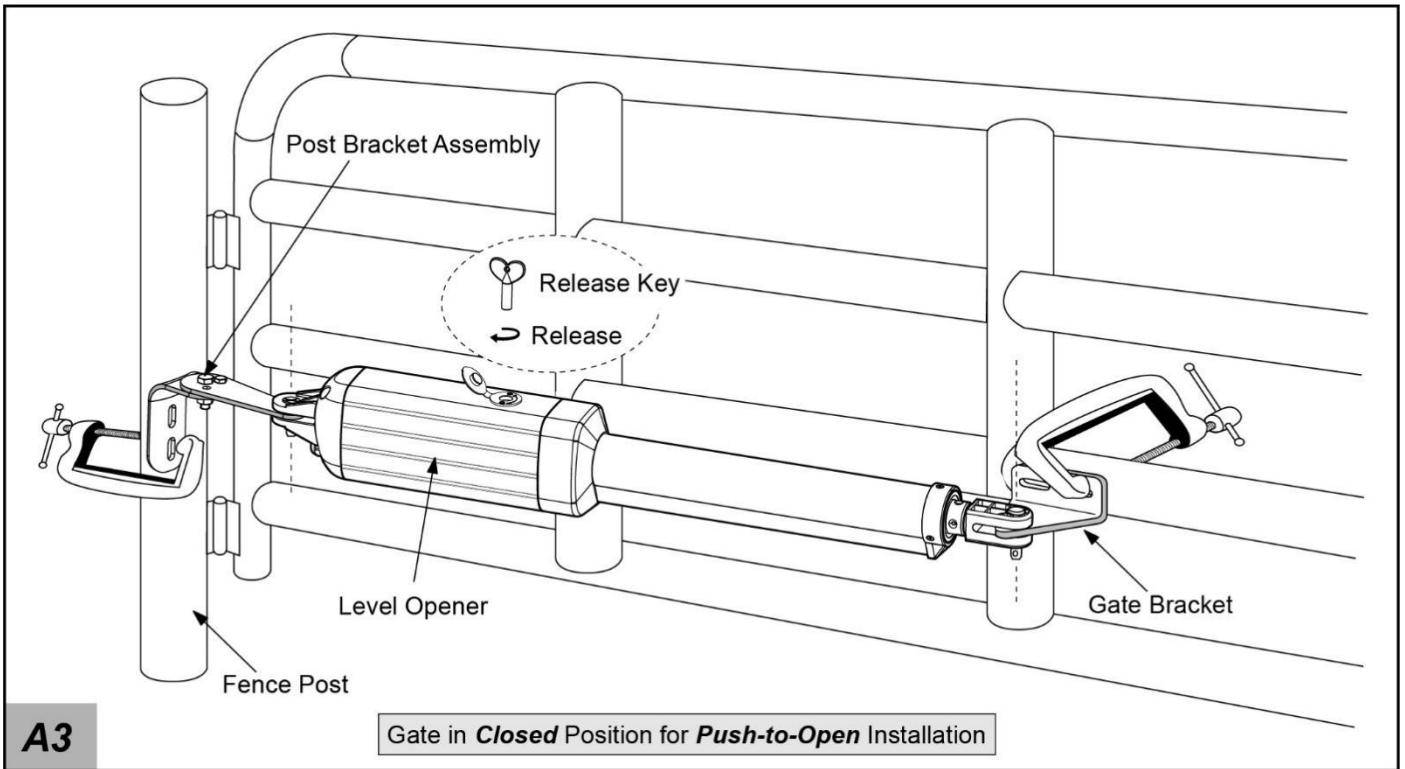

5. Make sure that there is a minimum clearance of 2.5cm between the gate and the opener and that the opener and the PSO part are not binding in both the gate-open and gate-closed positions. If there is not at least 2.5cm of clearance or if the opener and the PSO part are binding, rotate the PSO part and/or move the Post Bracket Assy. to obtain the minimum clearance and eliminate the binding.

Push-to-Open

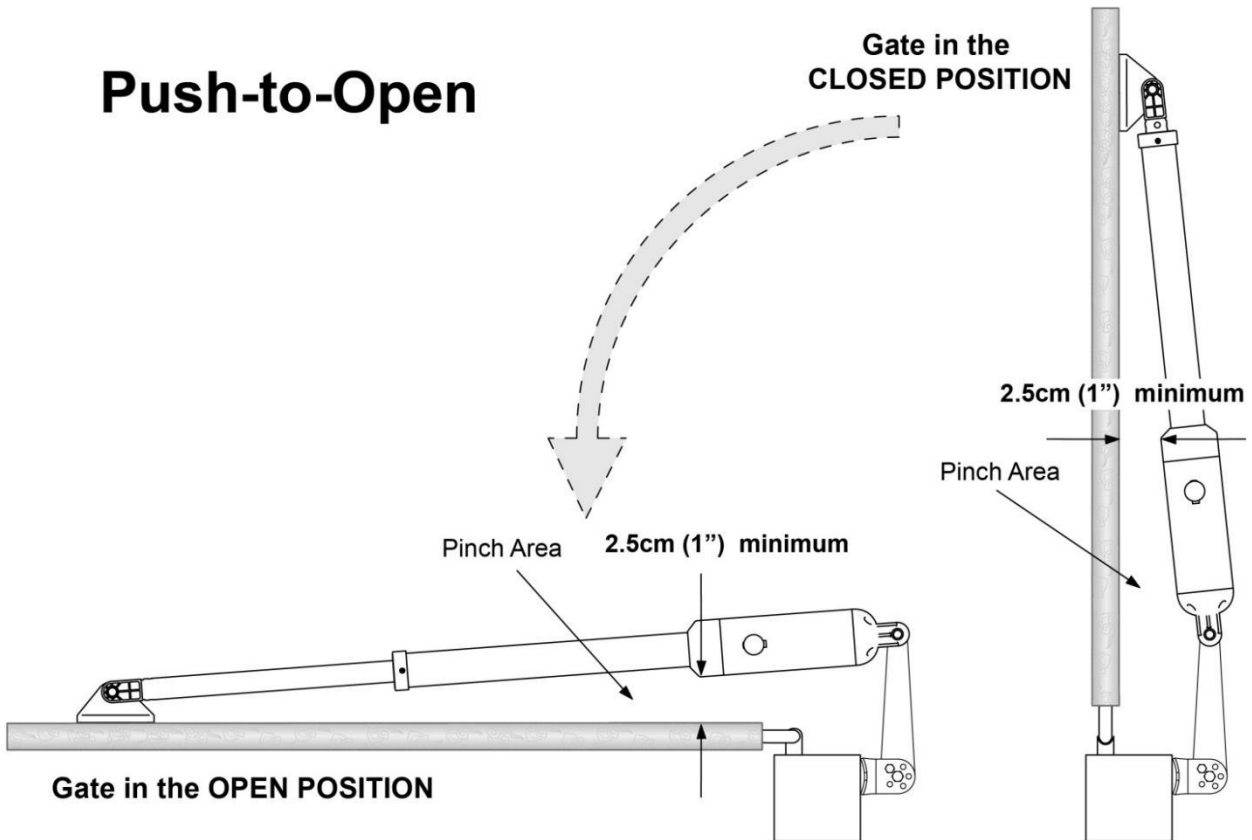

6. Sign the bolt-hole point on the gate post and gate. Do this by placing a punch or a sign in the middle of each bolt slot on the post bracket and the gate bracket. It allows slight adjustments to the post bracket. Then remove the opener and brackets assy. by taking off the C-clamps.

7. Drill 10.5 mm diameter holes through the post and the gate at the marked locations.

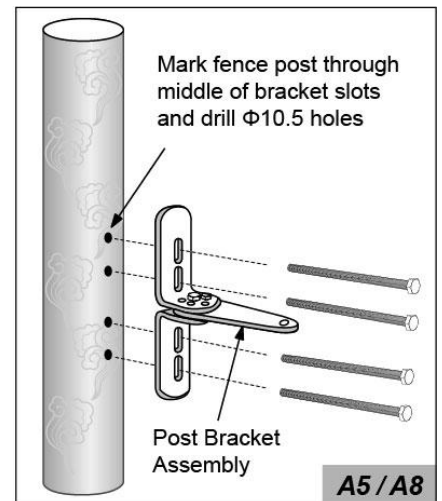
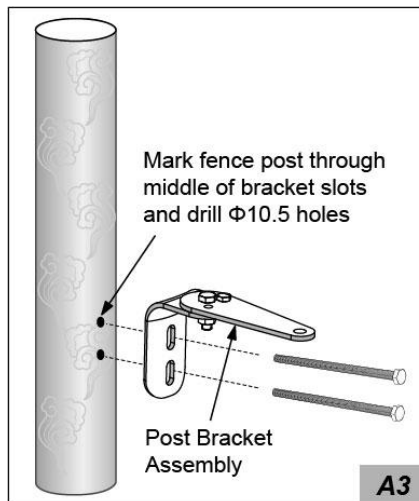

8. Attach the post bracket assemblies to the gate posts by inserting M10 x 200 bolts through each post bracket assy. and the drilled holes in the gate post. Fasten each bolt with one $\Phi 10$ washer, one $\Phi 10$ lock washer, and one $\Phi 10$ nut.

9. Attach the gate brackets to each gate by inserting two M10 x 75 bolts through the gate brackets and the drilled holes in the gates. Fasten each bolt with one $\Phi 10$ lock washer, and one $\Phi 10$ nut.

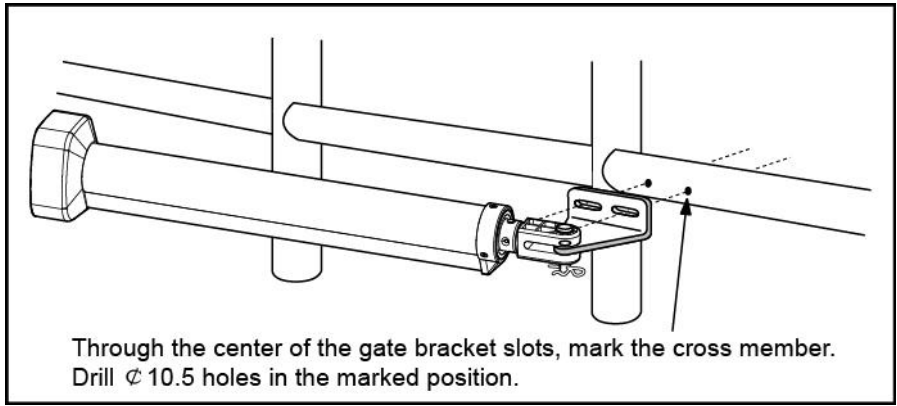

10. Cut off any part of the bolts that extend beyond the tightened nuts.

11. With the opener fully retracted and with the gate in the fully closed position (for Push-to-Open installation), insert a clevis pin through the gate opener and the Post Pivot Bracket and insert another clevis pin through the gate opener and the Gate Bracket. Secure each clevis pin with a hairpin clip.

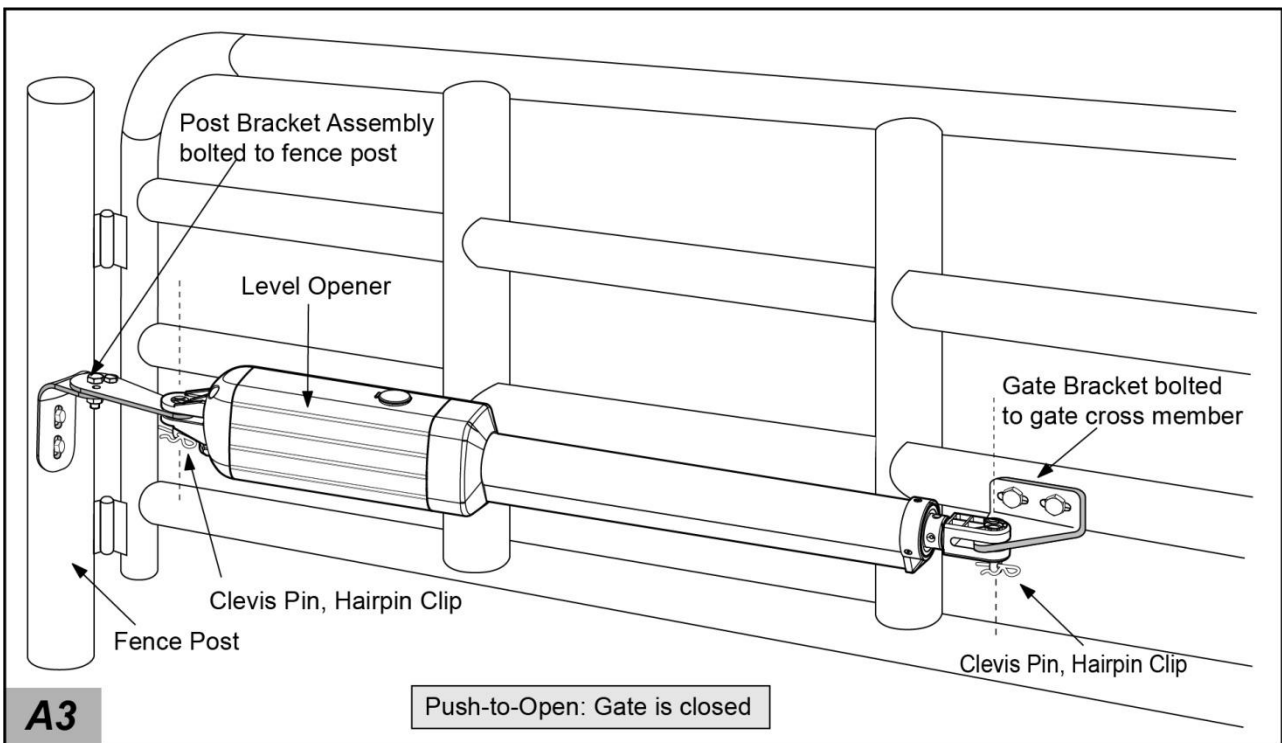

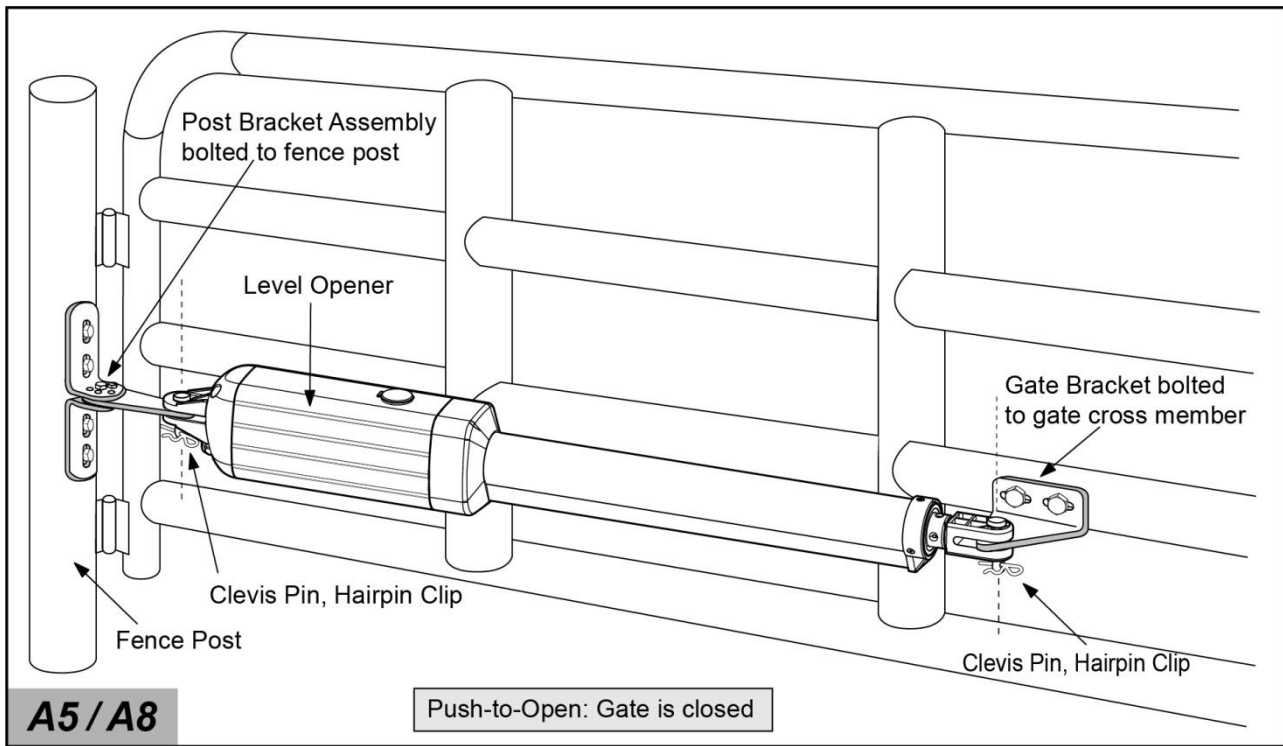

12. Open the release hole plug on the top of the gate opener, insert the release key, and turn the key 90° counterclockwise. This restores normal operation.

NOTE: The setting of the **PULL/PUSH TO OPEN** of the control board should be in accordance with the installation.

Mounting of the Control Box

Use 2 deck screws (not provided) to install the control box. Even though the control box is waterproof designed, for safety reason and a longer service life, it is recommended to install the control box inside a secure surface and at least 100 cm (40 inches) above the ground to avoid being flooded or buried under snow.



CAUTION: Make sure the cable outlet hole in the Control Box is always down during installation so as to drain off the water.

Connection of the Power Supply

⚠ The gate opener can be powered by 24V 12Ah battery (NOT INCLUDED) OR DPS180-U AC-DC Power Supply (NOT INCLUDED, available at TOPENS Store). The adapter included in the package is ONLY used to charge the battery.

⚠ Instead of using a battery, the AC-DC Power Supply is highly recommended as the power source to save the cost where AC electricity is accessible and stable.

⚠ If batteries are chosen as the power source, Marine or Automotive Type Battery with capacity

greater than 12 Ah is required. The batteries should be waterproof type, or be placed in water proof circumstance.

⚠️ 2 PCS 12VDC batteries can be connected in series to function as 24VDC. The following diagram shows on how to connect 2 PCS batteries in series. Charging mode for the battery could be by the adapter, by the solar panel, or both of them at the same time.

⚠️ Please note that the wire connection of the power supply system is very important. Incorrect wire connection will damage the control board.

⚠️ **WARNING: NEVER** connect the gate opener to the power outlet before all the installations have been done.

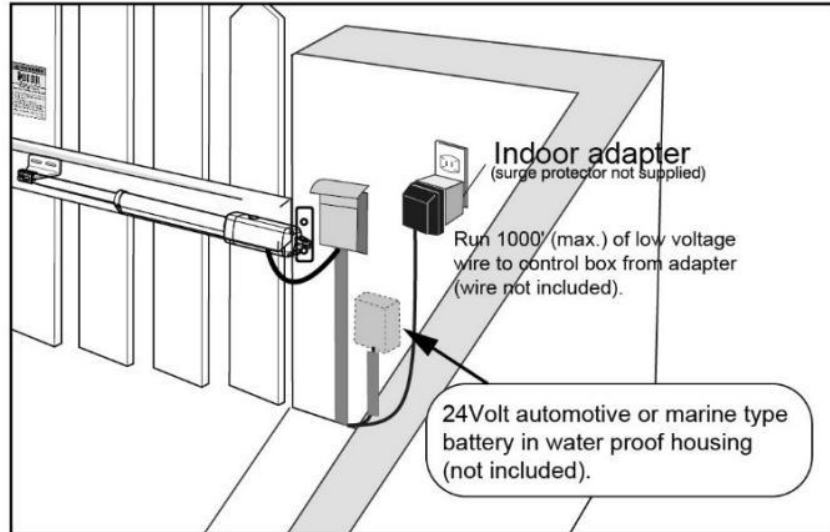

1. Use the batteries as the power source and only use the adapter to charge the batteries

The “24V+” of the battery should be wired to the **BAT+ (#11)** terminal, “24V-” should be wired to “**BAT- (#12)** terminal. **The wire [2*0.75mm² (2C*18AWG), 1 meter (3.3 feet) long] for connecting the battery has been provided and connected to the control board in factory.** The adapter should be wired to the “**ADAPTER (#13, #14)** terminals of the control board, no matter the polarity. The length of the wire of the adapter is 1.2m (4’). So if the distance between the outlet and the control box is longer than that, you should use an extended wire to connect the adapter to the control board. The wire size should be at least 1.3mm² (16AWG). If the distance is more than 100m (300’), the wire size should be at least 2mm² (14AWG). The maximum distance from the adapter to the control box is 300m (1000’).

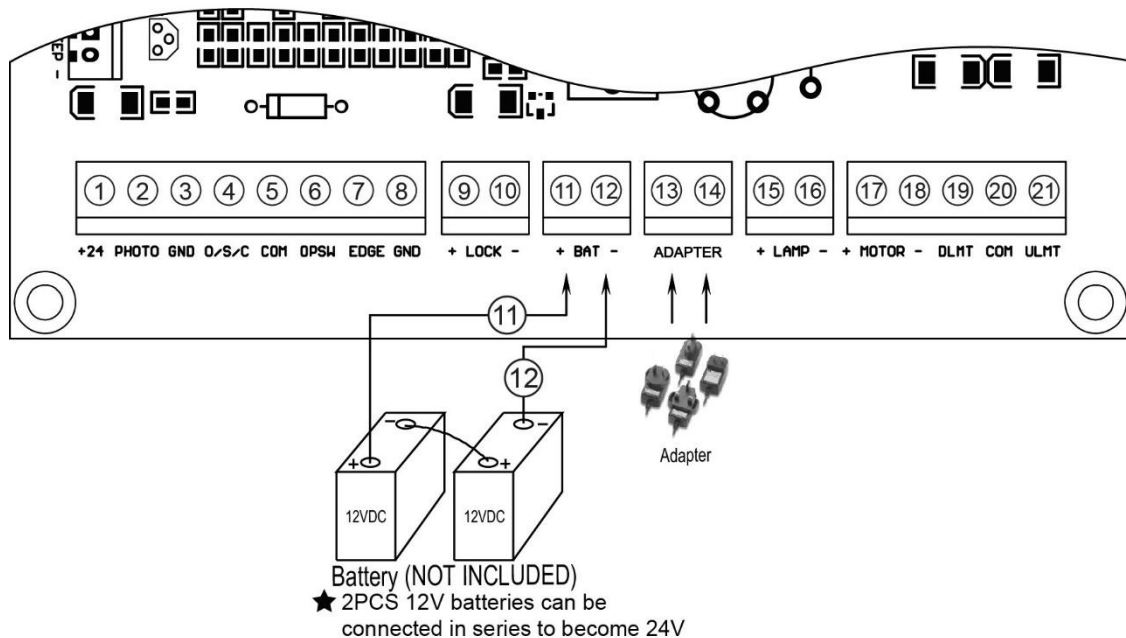

You can plug the adapter into the electrical outlet after all the wire connections are completed. Use a surge protector with the adapter is strongly recommended. If electrical outlet is located outdoors, outlet and adapter should be protected by a weatherproof cover.

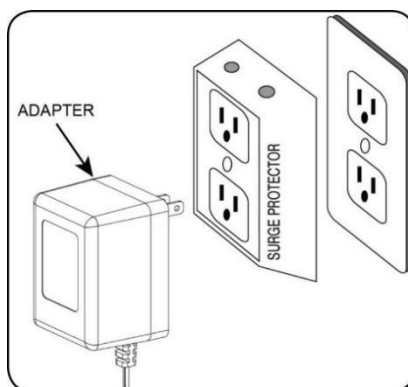

2. Use the batteries as the power source and use the adapter & solar panel to charge the batteries at the same time

If you want to use an optional **solar panel** to charge the battery **with the adapter at the same time**, a solar charge controller must be used to control it to charge the battery. You can connect adapter, the solar panel and the solar charge controller refers to the following illustration.

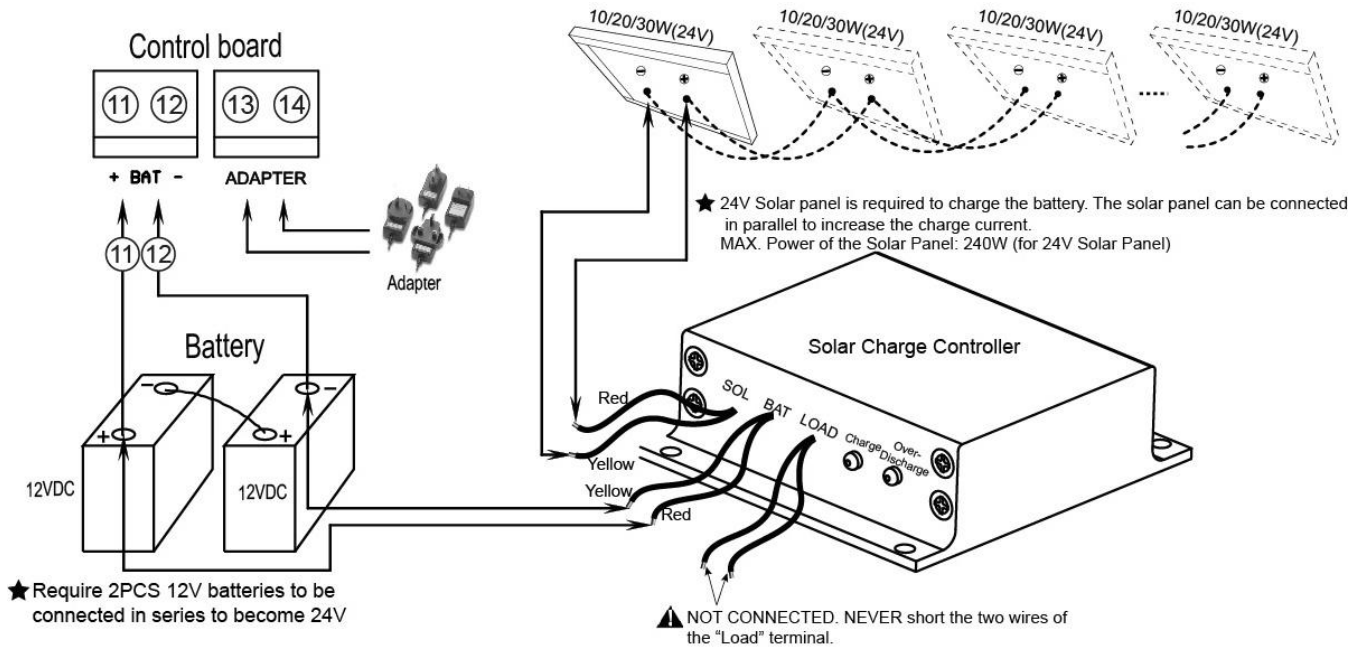

3. Use the batteries as the power source and only use the solar panel to charge the batteries

If you only use the solar panel to charge the batteries, please note the **power of the solar panel should be at least 20W**. The gate opener can work for **10 cycles per day** if there is no other accessory except photocell & electric lock & push button & alarm lamp connected to the control board. The capacity of the batteries and the power of the solar panel should be enlarged if you want to use more. You can connect the solar panel and the solar charge controller refers to the following illustration.

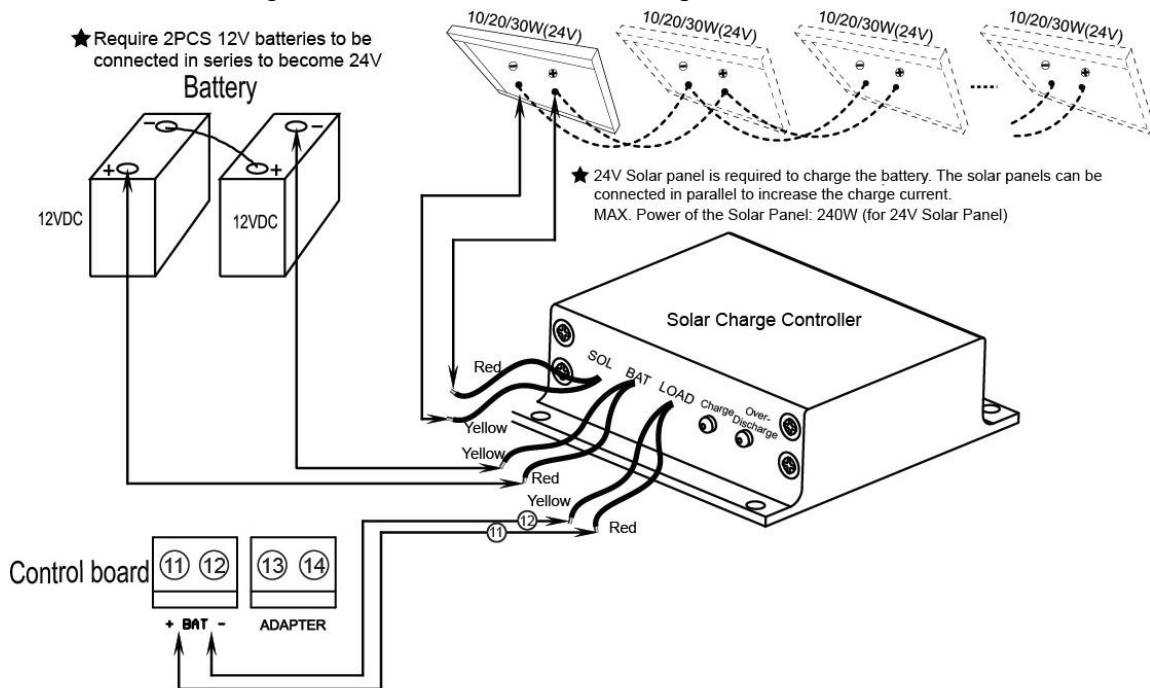

4. Use the DPS180-U AC-DC power supply as the power source if AC electricity is accessible and stable

The gate opener can be powered by an AC to DC 24V Power Supply (NOT INCLUDED). TOPENS DPS180-U Waterproof AC 110V-240V to DC 24V Power Supply is available at TOPENS Store. Instead of using batteries, this alternative save costs and is strongly recommended. The **positive output** of the 24VDC power supply

should be wired to the **BAT+** (#11) terminal, the **negative output** should be wired to “**BAT-**” (#12) terminal. **There is no need to use the adapter in this situation.**

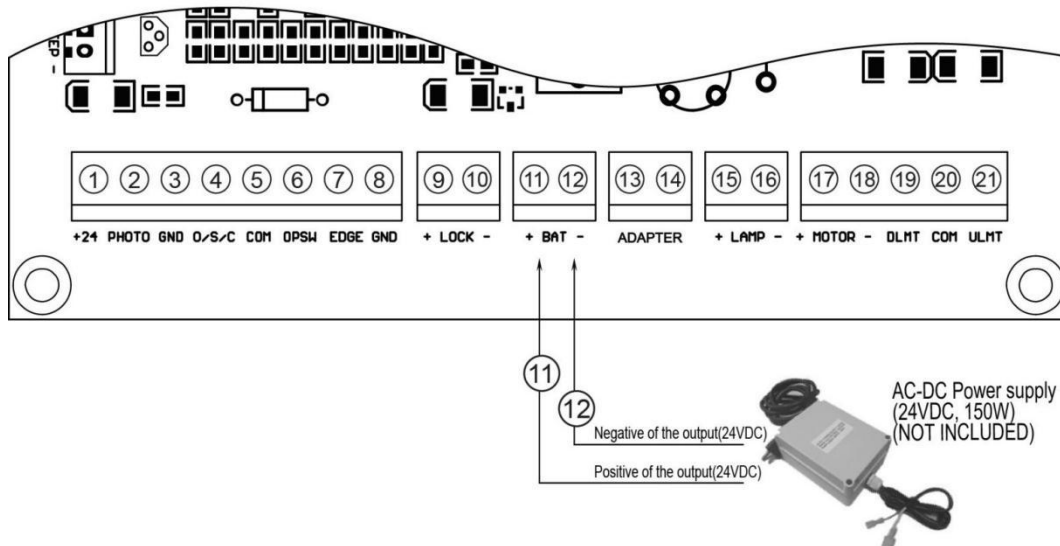

5. Use the UPS01 uninterrupted power supply as the power source

Firstly please connect the output of the power supply to power input of the gate opener control board. You can plug the load output wire of the power supply to the power input cable of the control box. A 2-core power input cable has been connected to the +BAT- (11# and 12#) terminal of the gate opener control board in factory. Please note that the polarity must be connected correctly or it may damage the control board (**Red wire is positive and yellow wire is negative**). Secondly please connect the battery to the power supply if you choose it as main power source or the back-up power. Thirdly you can connect the solar panel to the power supply if you choose it to charge the battery. Finally you can plug the AC cable to the AC main socket as needed.

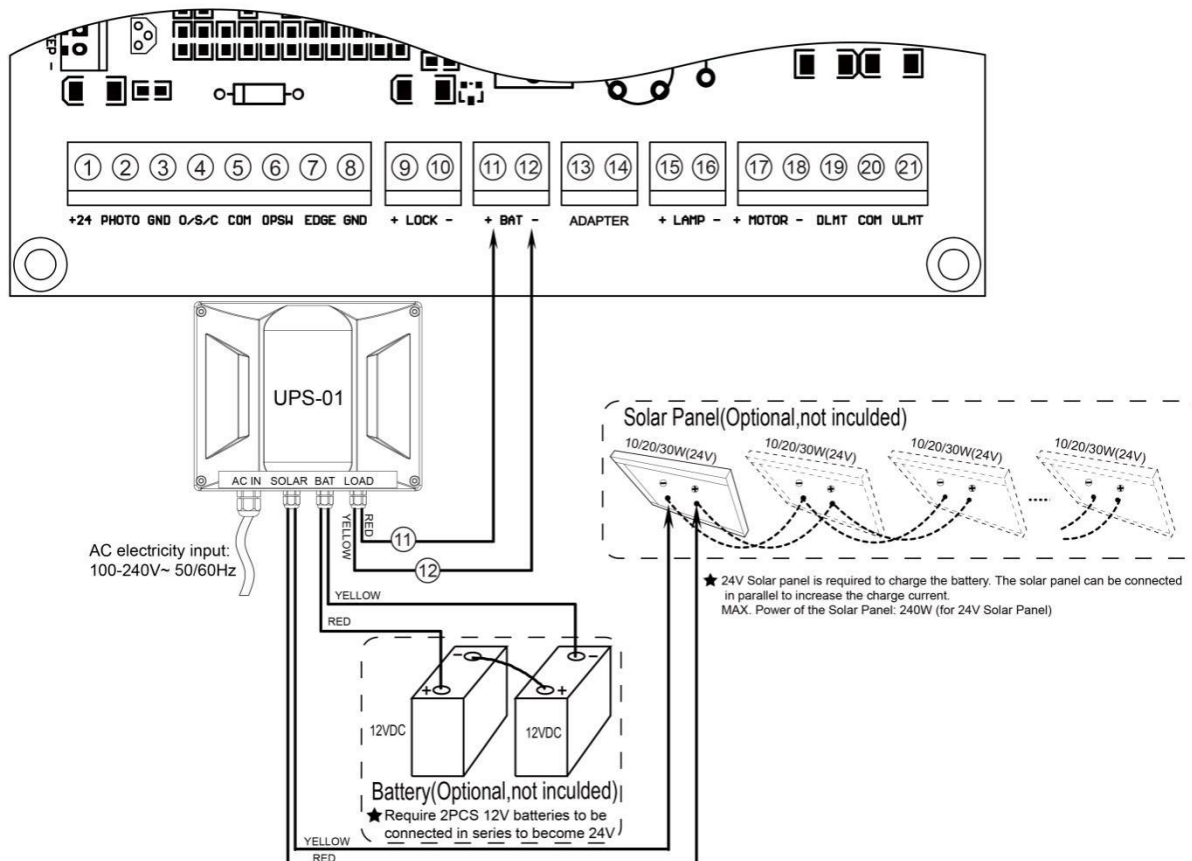

Connection of the Control Board

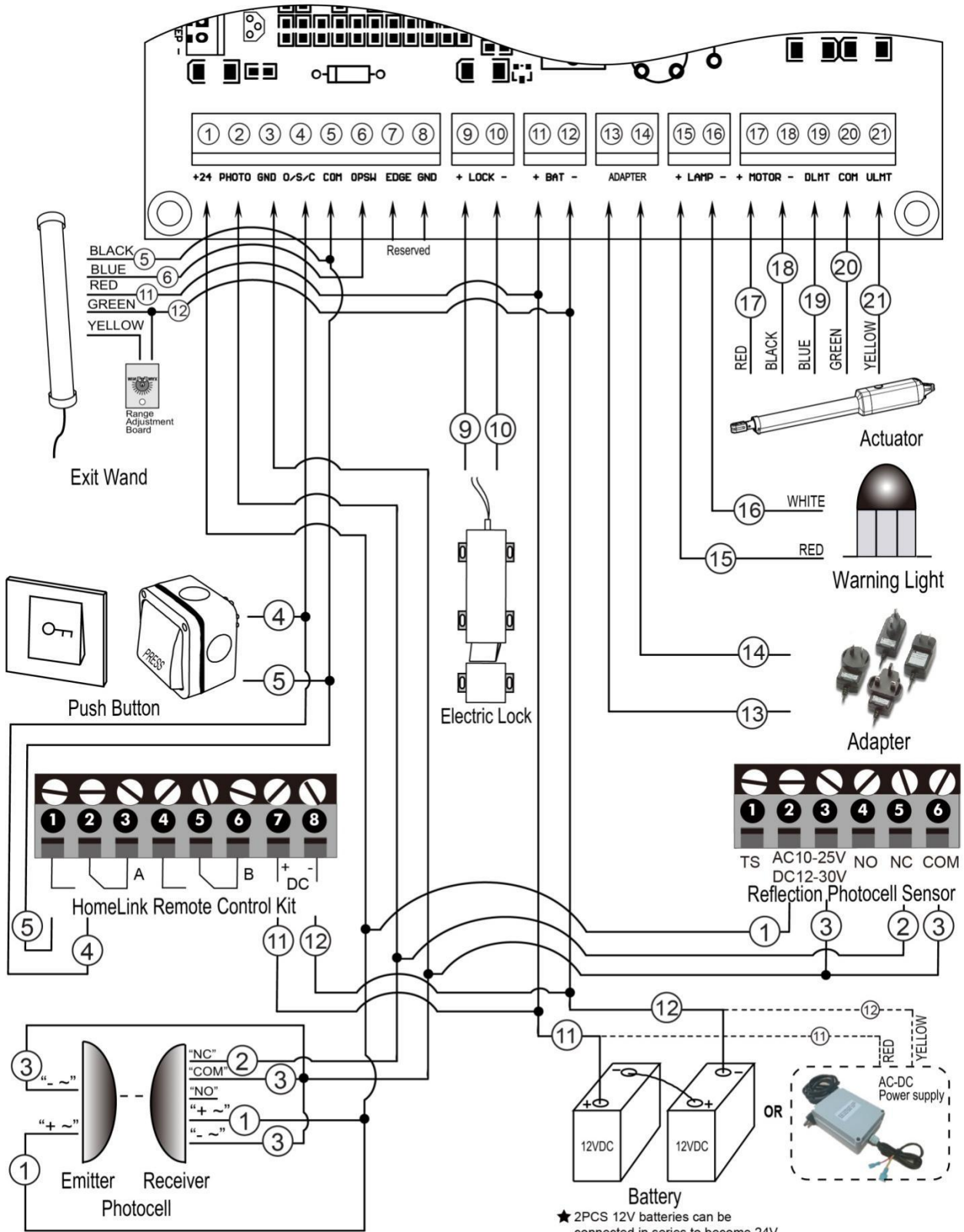

▲ Important Note:

This gate opener can be powered by 24V 12Ah battery (NOT INCLUDED) OR DPS180-U AC-DC Power Supply (NOT INCLUDED). The adapter included in the package is ONLY used to charge the battery. The AC-DC Power Supply is highly recommended as the power source to save the cost where AC electricity is accessible and stable.

1. Actuator

Insert the stripped cable wires into the appropriate terminals on the opener terminals block. The **red** wire should be inserted into the “+MOTOR” terminal(#17), the **black** wire into “MOTOR-” terminal (#18), the **blue** wire into “DLMT” terminal(#19), the **green** wire into “COM” terminal(#20), and the **yellow** wire into “ULMT” terminal (#21).

2. Battery OR AC-DC power supply (Required but not included)

Please connect them following the chapter of “**Connection of the power supply**”.

3. Adapter (Only used to charge the batteries)

Insert the stripped cable wires into **ADAPTER** (#13) terminals to the control board. No matter the polarity.

4. Warning Light (Included in some models, refers to the actual package)

The red wire of the warning light should be inserted into **+LAMP** (#15) terminal, the white wire into the **LAMP-** (#16).

5. Photocell Beam System (PBS) (Included in some models, refers to the actual package)

Use a 2-core cable to connect the “+ ~” terminal of the photocell’s emitter to the “**+24**” (#1) terminal, the “- ~” terminal to the “**GND**” (#3) terminal. Also the “+ ~” and “- ~” terminals of the photocell’s receiver should be connected to the “**+24**” and “**GND**” terminals in parallel.

Use another 2-core cable to connect the “**NC**” terminal of the receiver to the “**PHOTO**” (#2) terminal, the “**COM**” terminal to the “**GND**” (#3) terminal.

6. Reflection Photocell Sensor (optional)

The “**AC10-25V/DC12-30V**” terminals of the reflection photocell sensor should be connected to the “**+24**” (#1) and “**GND**” (#3) terminals, no matter the polarity.

The “**NC**” terminal should be connected to the “**PHOTO**” (#2) terminal.

The “**COM**” terminal should be connected to the “**GND**” (#3) terminal.

7. Push Button (optional)

The push button should be wired to the “**O/S/C**” (#4) and “**COM**” (#5) terminals. No matter the polarity. The gate operator works alternately by pressing the button (open-stop-close-stop-open).

8. Electric Lock (optional)

The electric lock should be wired to the “**+LOCK-**” terminal (“#9 and “#10” terminals), no matter the polarity of the wires.

9. Exit Wand (optional)

The **BLACK** wire of the exit wand should be connected into the “**COM**” (#5) terminal.

The **BLUE** wire of the exit wand should be connected into the “**OPSW**” (#6) terminal.

The **RED** wire of the exit wand should be connected into the “**BAT+**” (#11) terminal.

The **GREEN** wire of the exit wand should be connected into the “**BAT-**” (#12) terminal.

The sensitivity adjustment board should be wired to the **GREEN** wire and the **YELLOW** wire of the wand. No matter the polarity.

10. HomeLink Remote Control Kit (optional)

The “**1**” terminal should be connected to the “**COM**” (#5) terminal.

The “**2**” terminal should be connected to the “**O/S/C**” (#4) terminal.

The “**DC+**” terminal should be connected to the “**BAT+**” (#11) terminal.

The “**DC-**” terminal should be connected to the “**BAT-**” (#12) terminal.

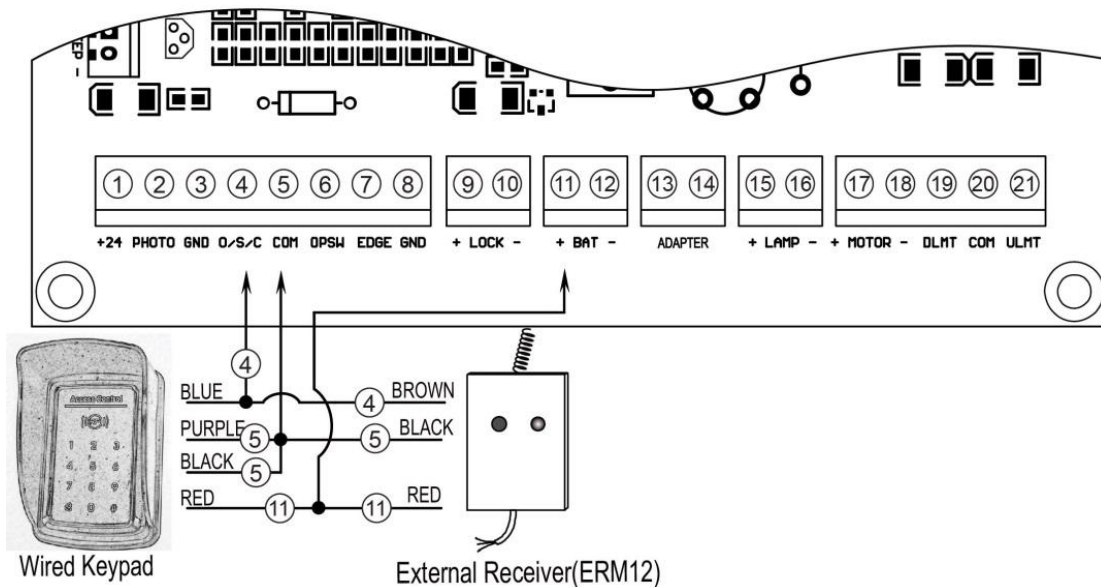

11. Wired Keypad (24VDC) (optional)

The **RED** wire of the wired keypad should be connected into the “**BAT+**” (#11) terminal.
 The **BLACK** wire of the wired keypad should be connected into the “**COM**” (#5) terminal.
 The **PURPLE** wire of the wired keypad should be connected into the “**COM**” (#5) terminal.
 The **BLUE** wire of the wired keypad should be connected into the “**O/S/C**” (#4) terminal.

12. External receiver (optional)

The **RED** wire of the external receiver should be connected into the “**BAT+**” (#11) terminal.
 The **BLACK** wire of the external receiver should be connected into the “**COM**” (#5) terminal.
 The **BROWN** wire of the external receiver should be connected into the “**O/S/C**” (#4) terminal.

Note: Using of the exit wand, keypad and external receiver would cause the battery exhausted quickly. Big capacity of battery and big power of solar panel(if the solar panel is used as main charger) is required if you want to use either of them.

How to Program the Remote to the Opener

- ✧ *The remote **MUST** be programed to the opener **BEFORE OPERATING**. Please follow the steps to program the remote.*
- ✧ *Activate the opener only when gate is in full view, free of obstruction and properly adjusted. No one should enter or leave gate area while gate is in motion. **DO NOT ALLOW CHILDREN to operate push button or remote. DO NOT ALLOW CHILDREN TO PLAY NEAR THE GATE.***
- ✧ *If you purchase additional remote controls, the gate opener must be programmed to accept the new remote code.*
- ✧ *If you lose one of any remote control, please erase and reprogram all other remote controls to have a new code for safety.*

Press and release the **CODE SW** button, the **CODE LED** will be ON, then press the key on the remote **two times** in 2 seconds, **between the two times HOLD ON FOR A MOMENT**, the **CODE LED** will flash for 3 seconds and then to OFF. Now the remote has been programmed successfully.

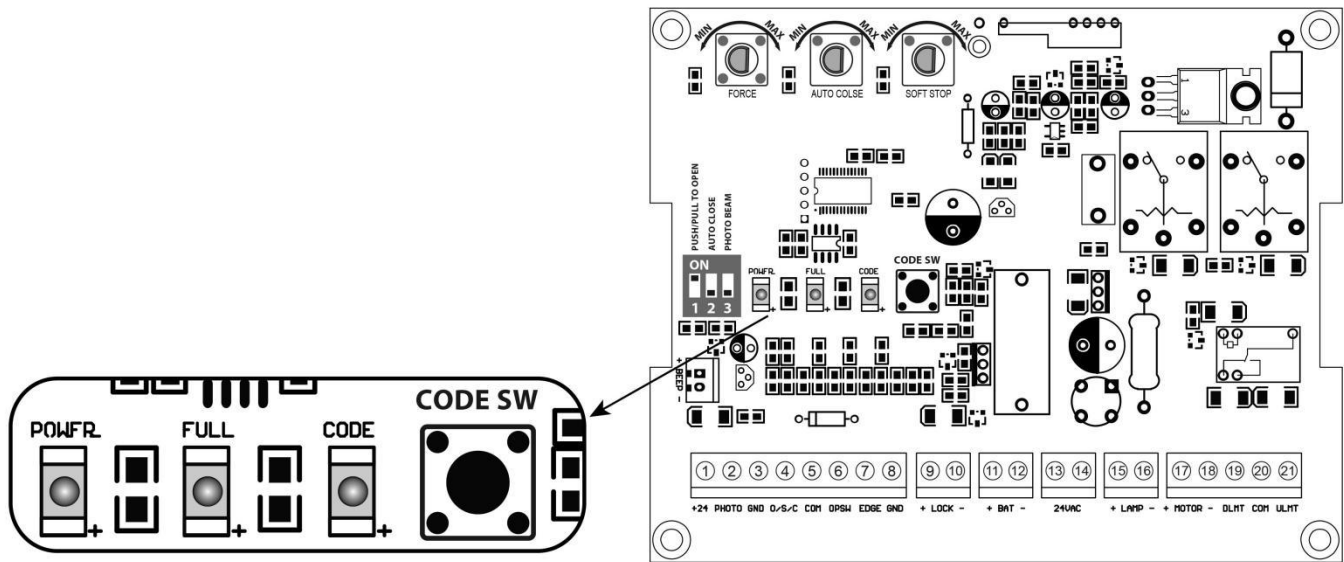

- ✧ **NOTE: Max. 8 remotes can be programmed for the opener. An External Receiver (optional) allows up to 250pcs remotes to be programmed for the opener. TOPENS ERM12 Universal External Receiver is available at TOPENS Store.**
- ✧ **TOPENS ERM12 Universal External Receiver is also compatible with other brand swing gate opener, sliding gate opener and garage door opener.**

How to Erase All the Remote Codes

Press and hold the **CODE SW** button until the **CODE** LED from ON to OFF. Now all remote codes have been erased.

How to Use the Remote to Operate Your Gate Opener

Each remote has four buttons, from top to bottom are separately A, B, C and D. You may use this remote to operate as many as 4 sets TOPENS swing gate openers or 1 set TOPENS sliding gate opener and 2 sets TOPENS swing gate openers.

1. Use this remote to only operate TOPENS swing gate opener A, B, C and D four buttons share same function once they are programmed with TOPENS swing gate opener. You may choose any button to program it with our swing gate opener. Every press of the button is able to active the gate opener to work alternately (open-stop-close-stop-open).

2. Use one remote to operate TOPENS swing gate opener & sliding gate opener at the same time

All of TOPENS sliding gate opener have midway mode. Button B is designed to realize midway function (refer to more details in our TOPENS sliding gate opener manual). So it is must program button A with sliding gate opener, while you may program either C button or D button with TOPENS swing gate opener.

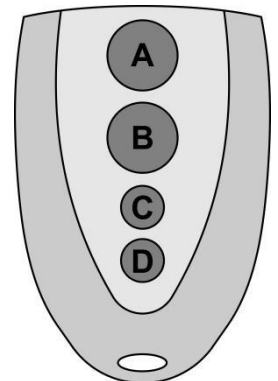

Wireless Keypad Programming

You can follow the below steps to program wireless keypad to the opener. Press the **CODE SW** button until the **CODE** LED is ON, and then releases the button. Then press "OK" button on keypad and **CODE** LED will flash for 3 seconds and then be OFF which indicates the keypad has been programmed successfully. You can use

the default password “888888” to operate the opener after programming. You can press “PIN” “8 8 8 8 8 8” and then press “OK” to confirm to operate the opener.

Also you can change the password of the keypad follow the below steps. Press “PIN” and then input the six digits old password and then press ”PIN” again, the **CODE LED** will be ON. Input the six digits new password and then press the “PIN” to confirm the new setting, **CODE LED** will flash for 3 seconds and then be OFF which indicates the password has been changed successfully. You can press “PIN” “6 digits new password” and then press “OK” to confirm to operate the opener.



Wireless Keypad

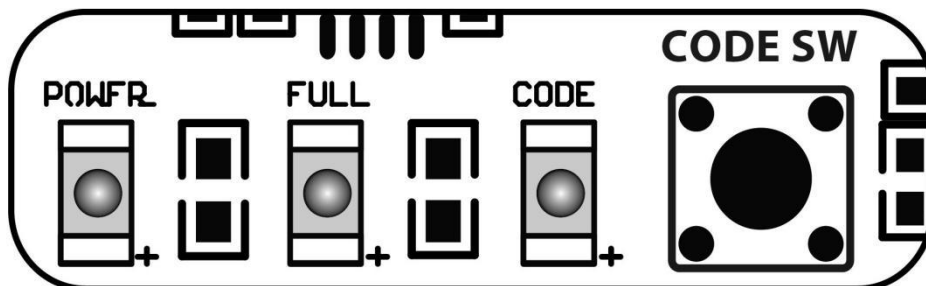

NOTE: Every step for pressing button during program must be finished within 1 second to ensure successful programming.

Adjusting the Limit Switch

Note: Before adjusting the limit switch, refer to the chapter of “Install the Opener on the Gate”, and make sure that the rod is fully retracted when the gate is in the fully open position (for Pull-to-Open installation), or in the fully closed position (for Push-to-Open installation). Make sure that currently the rod is fully retracted.

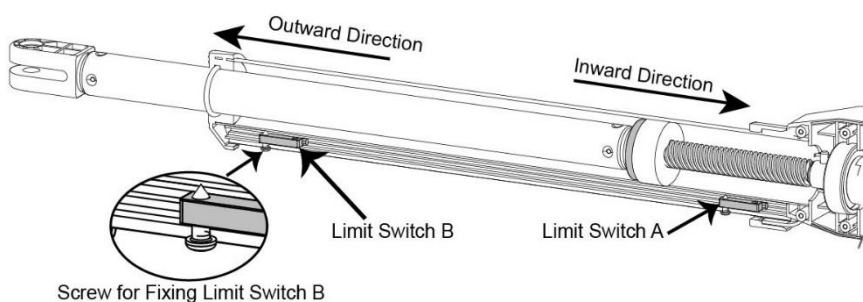

Note: The position of Limit Switch A was fixed in factory, do not adjust it again.

1 For Pull-to-Open Installation, adjust the limit switch B to determine the closed position:

Turn on power to operate the gate opener, then the arm extends to close the gate.

If the arm closes over the desired closed position, press the remote control to stop the opener. Use a screwdriver to loosen the screw of the limit B, slightly slide the limit switch B **inwards**.

If the arm closes halfway and fails to get to the desired closed position, slightly slide the limit switch B **outwards**.

Please **repeat** the above steps, until the arm could arrive and automatically stop at the desired close position. Then tighten the screw firmly.

Limit setting is finished now.

2 For Push-to-Open Installation, adjust the limit switch B to determine the open position:

Turn on power to operate the gate opener, then the arm extends to open the gate.

If the arm opens over the desired open position, press the remote control to stop the opener. Use a screwdriver to loosen the screw of the limit B, slightly slide the limit switch B **inwards**.

If the arm opens halfway and fails to get to the desired open position, slightly slide the limit switch B **outwards**.

Please **repeat** the above steps, until the arm could arrive and automatically stop at the desired open position. Then tighten the screw firmly.

Limit setting is finished now.

Setting of the Control Board

⚠ WARNING: Ensure the gate opener is Power Off when you make any adjustment of the gate opener. Keep away from the gate during you set the gate opener system in case of the unexpected gate moving. Carefully adjust the DIP switches to avoid the risk of machine damage and injury or death. Always ask the help of professional technician /electrician if you have any question.

1. DIP Switches

The DIP switches are used to select pull/push to open, enable/disable auto close function, enable/disable photocell function.

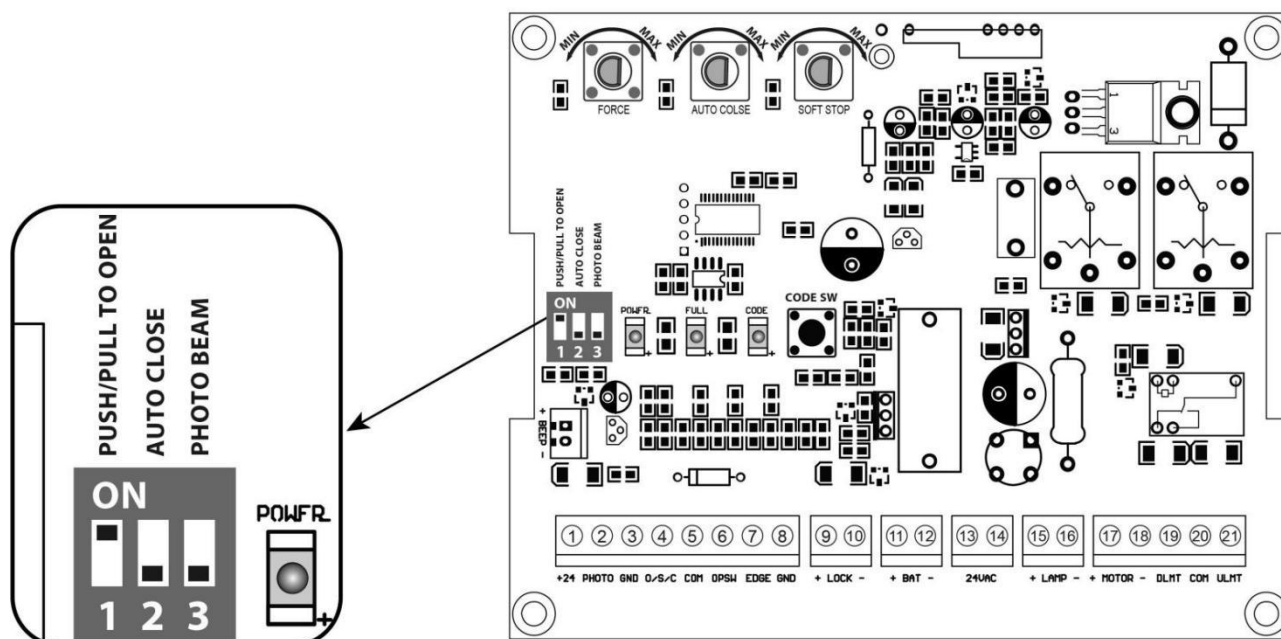

DIP Switch #1: Select push/pull to open

If the gate opens into the property (**pull to open**), the DIP Switch is set to **OFF** (factory default setting). If your gate opens out from the property (**push to open**) the DIP Switch must be set to the **ON** position. Factory default setting is **OFF**.

DIP Switch #2: Auto close function enabled/disabled

ON – Auto close function **enabled**

OFF – Auto close function **disabled**

Set the switch #2 to ON to enable the auto close function. Factory default setting is **OFF**.

⚠ Important Note: When the auto close function is enabled, the photocell sensor is highly recommended to be installed with the gate opener for safety.

DIP Switch #3: Photocell function enabled/disabled

ON – Photocell function **enabled**

OFF – Photocell function **disabled**

You must set the switch #3 to ON to enable the photocell function if you want to use the photocell with the gate opener. Factory default setting is **OFF**

2. Potentiometers

There are 3 potentiometers located in the control board. They are used to adjust the stall force, auto-close time and soft stop period.

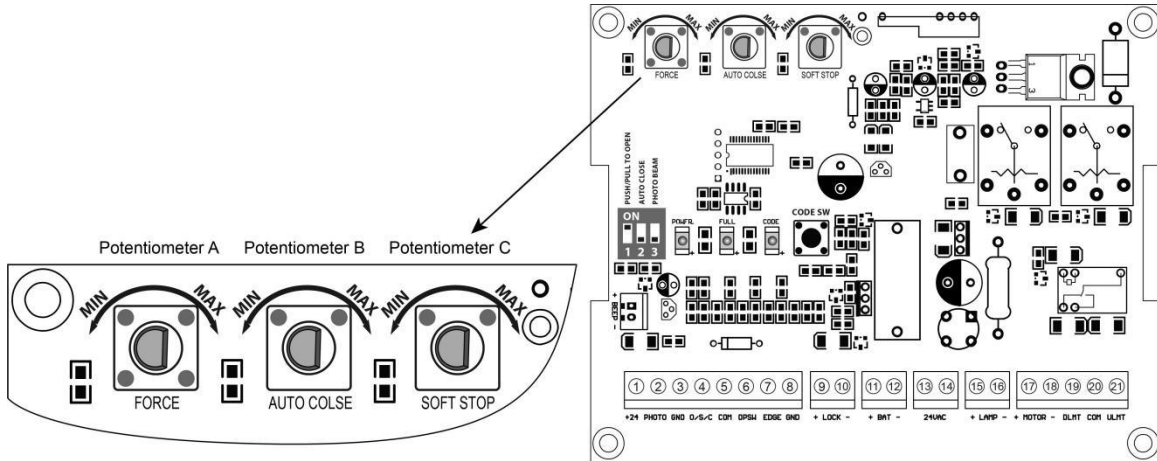

Potentiometer A is used to adjust the stall force the gate opener. Turn the potentiometer clockwise to increase the stall force, and turn it counter-clockwise to decrease the stall force.

Potentiometer B is used to adjust the auto close time of the gate opener. Turn the potentiometer clockwise to increase the auto close time, and turn it counter-clockwise to decrease the auto close time. The auto close time can be adjusted gradually from 3 to 120 seconds.

Potentiometer C is used to adjust the soft stop period of the gate opener. Turn the potentiometer clockwise to increase the soft stop period, and turn it counter-clockwise to decrease the soft stop period. The soft stop period can be adjusted gradually from 1 to 5 seconds.

Maintenance

Warning: Disconnect power before servicing.

1. Using a clean, dry cloth to wipe the gate opener shaft, and then apply a silicone spray to reduce its friction. In cold climates where temperatures reach 1°C (30°F) or less, spray silicone on the actuator every 4~6 weeks to prevent freeze up.
2. Regularly check gate hinges to make sure gate is swinging smoothly and freely. Grease hinges if needed.
3. Check your installation periodically, as hardware and posts will shift. Brackets may need to be adjusted or hardware may need to be tightened.
4. Maintain the area around your gate. Keep the areas free of objects that can prevent the gate swinging freely.

NOTES:

1. Inspection and service should always be performed anytime a malfunction is observed or suspected.
2. It is suggested that while at the site voltage readings be taken at the operator. Using a Digital Voltmeter, verify that the incoming voltage to the opener it is within ten percent of the opener's rating.
3. Refer to the instructions on how to check gate force and sensitivity adjustments.

Trouble Shooting



**Need help or have questions? DO NOT RETURN to the store.
Visit www.topens.com to CONTACT US.**

Have a multi-meter to check voltage and continuity. Use caution when checking high voltage terminals.

Symptom	Possible Solution(s)
The opener does not run. Only the CODE LED is ON slightly.	1. The batteries are not connected to the control board or the wire connection of the batteries is loosened. Please note that a 2*12V batteries is required to power up the gate opener. The adapter which is included in the package is only used to charge the batteries.
The opener does not run. Power LED flash rapidly (the LED is ON 200ms per second, normally the LED ON 500ms per second).	1. Battery is over-discharge. Check the voltage of the battery. The voltage of the battery should above 22V to make the gate opener work normally.
The opener does not run. Power LED does not ON.	1. Make sure the connection between the battery and control board is correct and fastening. 2. Check the fuse in the control board. Replace the fuse if it was burnt out. 3. Check the control board. Replace the control board if necessary.
Gate moves a little and then reverse or stop	1. The selected force is too small to move the gate. Turn the Potentiometer clock-wise to increase the force. 2. Disconnect the gate from the gate operator and check that the gate slides freely without any binding.
Gate opener does not run when you press the remote control	1. Make sure the remote has been programmed to the control board before using. 2. The battery of the remote may be exhausted. Replace the battery and try it again. 3. Check if the limit switch is broken. Remove the BLUE&GREEN&YELLOW wires of the arm from the control board and use a jumper wire to short the ULT&COM&DLT terminals of the control board which for connecting the three wires and then try it again. The limit switch of the arm is faulty if the arm could run normally. 4. The control board could be faulty. Replace the control board as necessary.
Gate can open but does not close	1. Make sure the connection of the photocell beam is not blocked if the photocell is used. 2. Check if the closed limit switch is broken. Remove the BLUE&GREEN&YELLOW wires of the arm from the control board and use a jumper wire to short the ULT&COM&DLT terminals of the control board which for

	<p>connecting the three wires and then try it again. The limit switch of the arm is faulty if the arm could run normally.</p> <p>3. The control board could be faulty. Replace the control board as necessary.</p>
Gate automatically opens, but does not automatically close	<p>1. Setting of DIP switch #1 would be wrong. Please set the dip switch correctly according to the push/pull to opener installation of the gate opener.</p>

DECLARATION OF CONFORMITY



CTS

CTS (NINGBO) TESTING SERVICE TECHNOLOGY
OPERATE ACCORDING TO ISO/IEC 17025

EC DECLARATION OF CONFORMITY

EU - ELECTROMAGNETIC COMPATIBILITY DIRECTIVE -

This declares that the following designated product

swing gate opener

Model No.: EK700M, EK280, EK365,
A3(EK280), A5(EK365), A8(EK700M)

(Product identification)

Complies with the essential protection requirements of the European Parliament and of the Council Directive 2014/30/EU on the approximation of the laws of the Member States relating to electromagnetic compatibility.

This declaration applies to all specimens manufactured in accordance with the attached manufacturing drawings which form part of this declaration.

Assessment of compliance of the product with the requirements relating to electromagnetic compatibility was based on the following standards:

EN 55014-1:2017,
EN 55014-2:2015

(Identification of regulations / standards)

This declaration is the responsibility of the Applicant / importer

HANGZHOU SANFORD TOOLS CO.,LTD.
8 SHENG Di ROAD , YUHANG TOWN, HANGZHOU 311121 ,CHINA

(Name / Address)



THIS DOC IS ONLY VALID IN CONNECTION WITH TEST REPORT NUMBER: CNB3180705-00517-E

MANUFACTURER / IMPORTER

TEST LABORATORY

This is the result of test, that was carried out from the submitted type-samples of a product in conformity with the specification of the respective standards.

The declaration holder has the right to fix the CE-mark for EMC on the product complying with the inspection sample

(Date)

17 July 2018

(Date)

(Surname, forename)

(Company stamp)

(Company stamp)



CTS (Ningbo) Testing Service Technology Co., Ltd.
NB test site: Fl.1 & 8 West, Bldg. B, No. 66, Qingyi Rd., Hi-Tech Zone, Ningbo, Zhejiang, China
GZ test site: A101, No.65, Zhuji Road, Tianhe District, Guangzhou, Guangdong, China

DECLARATION OF CONFORMITY



**CENTRE OF TESTING SERVICE
OPERATE ACCORDING TO ISO/IEC 17025**

**EC DECLARATION OF CONFORMITY
EU - LOW VOLTAGE DIRECTIVE -**

This declares that the following designated product:

Swing gate opener
Model No.: EK700M, EK280, EK365, A3(EK280)
A5(EK365), A8(EK700M)
.....
(Product identification)

Complies with the requirements of the European Community Directive 2014/35/EU.
This declaration is awarded following tests carried out on samples of the product referred to above.
Assumption of compliance of the product with the requirements relating to the
Low Voltage Directive (LVD) was based on the following standards:

EN 60335-1: 2012+A11:2014
EN 60335-2-103:2015
.....
(Identification of regulations / standards)

This declaration is the responsibility of the manufacturer / importer

HANGZHOU SANFORD TOOLS CO., LTD.
8 SHENG DI ROAD, YUHANG TOWN, HANGZHOU 311121, CHINA
.....

(Name / Address)



THIS DOC IS ONLY VALID IN CONNECTION WITH TEST REPORT NUMBER: CNB3180705-00519-I.

MANUFACTURER / IMPORTER

.....
(Date)

.....
(Surname, forename)
(Company stamp)

TEST LABORATORY

This is the result of test that was carried out from the submitted type-samples of a product in conformity with the specification of the respective standards.
The declaration holder has the right to fix the CE-mark for LVD on the product complying with the inspection sample.

31 July 2018
(Date)

ky shang
.....
(Company stamp)



CTS (Ningbo) Testing Service Technology Co., Ltd.
Fl.1 & 8 West, Bldg. B, No. 66, Qingyi Rd., Hi-Tech Zone, Ningbo,
Zhejiang, China



According to Waste of Electrical and Electronic Equipment (WEEE) directive, WEEE should be separately collected and treated. If at any time in future you need to dispose of this product please do NOT dispose of this product with household waste. Please send this product to WEEE collecting points where available.

Feedback & Review

Your comments and suggestions are important to us
as they help us provide the best possible service.

Should you have any need to contact us, the info below will help you get in touch:



TOPENS Website

www.topens.com

Contact Us:

E-mail: support@topens.com

*Kindly include your Product Model, Purchasing Date & Site, Order #,
and your contact information. All your concerns will be replied within 24 hours.*

Tel: +1 (888) 750 9899 (Toll Free USA & Canada)