

OWNER'S MANUAL

STANLEY[®]
HOME AUTOMATION

U-INSTALL[®] GARAGE DOOR OPENERS

OWNER'S MANUAL

FOR USE ON MOST TYPES OF GARAGE DOORS

- **DO NOT THROW THIS MANUAL AWAY.**
Keep in a safe location for future reference.
- Do not connect to power until instructed to do so.
- Do not run door opener until completely installed.
- Door opener will not operate until beam sensor is installed and properly aligned.
- For your protection, wear safety glasses.

Read and follow ALL instructions carefully.

021.0259E

FOR INSTALLATION ASSISTANCE
CALL THE TOLL FREE
HELP LINE!
1-800-521-5262

Important Installation Instructions

Dear Homeowner,

Please take a moment to read the following **IMPORTANT INSTALLATION INSTRUCTIONS** prior to beginning assembly and installation of your new garage door opener.



THIS CAUTION SYMBOL APPEARS PERIODICALLY THROUGHOUT THIS MANUAL. IT WILL IDENTIFY IMPORTANT SAFETY INSTRUCTIONS.

WARNING – These safety instructions must be followed **TO REDUCE THE RISK OF SEVERE INJURY OR DEATH** to persons installing, using or in the vicinity of the garage door or garage door opener.

A. **BE SURE TO READ AND FOLLOW ALL INSTALLATION INSTRUCTIONS.**

B. **INSTALL THE GARAGE DOOR OPENER ONLY ON A PROPERLY BALANCED AND LUBRICATED GARAGE DOOR. AN IMPROPERLY BALANCED DOOR COULD CAUSE SEVERE INJURY.**

LUBRICATE YOUR DOOR BY APPLYING A LIGHT OIL OR SILICONE LUBRICANT TO THE DOOR HINGES, MOUNTING HARDWARE AND THE ROLLER BEARINGS. YOUR DOOR SHOULD MOVE FREELY BY HAND WITHOUT STICKING OR BINDING. DO NOT APPLY OIL OR GREASE TO THE ROLLER TRACKS. CONDUCT DOOR BALANCE TEST BEFORE BEGINNING INSTALLATION.

DOOR BALANCE TEST

Raise your door to its mid-point and release it. The door should remain in this position without moving up or down.

If the door is moved to the 3/4 open position and released, it should remain in place or move slowly to the full open position.

If the door is moved to the 3/4 close position and released, it should remain in place or move slowly to the full close position.

If the door fails any of these three door tests, the springs may be out of adjustment. **Have a qualified service person make repairs to cables, spring assemblies and other hardware before installing the opener.** Some parts are under **EXTREME** tension at times and can cause serious injury if improperly handled.

C. **REMOVE ALL ROPES AND REMOVE OR MAKE INOPERATIVE ALL LOCKS CONNECTED TO THE GARAGE DOOR BEFORE INSTALLING OPENER.** ACCIDENTAL ENGAGEMENT OF DOOR LOCKS MAY RESULT IN DAMAGE TO DOOR OR OPENER AND POSSIBLE PERSONAL INJURY.

D. **IF POSSIBLE, INSTALL DOOR OPENER 7 FEET OR MORE ABOVE THE FLOOR.** THIS MAY NOT BE POSSIBLE WITH MOST ONE-PIECE DOORS. IN THIS CASE INDIVIDUALS OVER 6 FOOT SHOULD BE ALERT TO THIS POTENTIAL OBSTACLE WHILE IN THE GARAGE.

E. **MOUNT THE RED EMERGENCY RELEASE KNOB 6 FEET ABOVE THE FLOOR.** IT SHOULD BE REACHABLE BY ADULTS IN THE HOUSEHOLD TO ALLOW MANUAL USE OF THE GARAGE DOOR IN AN EMERGENCY.

F. **DO NOT CONNECT OPENER TO POWER SOURCE UNTIL INSTRUCTED TO DO SO.** EXTENSION CORDS SHOULD NOT BE USED. THE OPENER MUST BE PLUGGED INTO A PROPERLY-GROUNDED 120 VOLT THREE-PRONG OUTLET.

G. **LOCATE THE PUSHBUTTON CONTROL BUTTON WITHIN SIGHT OF THE DOOR AND AT A MINIMUM HEIGHT OF 5 FEET ABOVE THE FLOOR SO SMALL CHILDREN CANNOT REACH IT. MOUNT IT AWAY FROM ALL MOVING PARTS OF THE DOOR.**

H. **BE SURE TO INSTALL THE ENTRAPMENT WARNING LABEL NEXT TO THE CONTROL BUTTON. READ THE CONTROL ADJUSTMENT WARNING LABEL ON THE REAR OF THE OPENER AND ALSO THE EMERGENCY RELEASE TAG,** WHICH IS INSTALLED ON THE EMERGENCY RELEASE CORD OF THE TRAVELER.

I. **AFTER INSTALLING DOOR OPENER, THE DOOR MUST REVERSE WHEN IT COMES IN CONTACT WITH A 1-1/2 INCH HIGH OBJECT (OR A 2X4 BOARD LAID FLAT ON THE FLOOR).** CHECK THE SAFETY REVERSING MECHANISM OFTEN (ONCE A MONTH IS RECOMMENDED) TO ENSURE IT REVERSES WITH A MINIMUM AMOUNT OF FORCE. **THIS MUST BE RETESTED ANY TIME AN ADJUSTMENT IS MADE TO THE DOOR ARM, FORCE ADJUSTMENTS, OR CLOSED POSITION ADJUSTMENT.**

J. **IF DAMAGE TO ANY MECHANICAL DRIVE OR STRUCTURAL COMPONENT OF UNIT IS OBSERVED DISCONTINUE USE AND CONTACT AN AUTHORIZED GARAGE DOOR/DOOR OPENER DEALER OR THE CONSUMER SERVICE DEPARTMENT IMMEDIATELY. NEVER OPERATE THE OPENER IF THE SYSTEM IS NOT FUNCTIONING PROPERLY OR IF IT WILL NOT REVERSE OFF OF A 1-1/2 INCH HIGH OBJECT.**

Features

CONTROLS

Your new garage door opener offers momentary control. To operate the door simply press either the hand held transmitter button or the wall mounted pushbutton for one to two seconds and the door will automatically open or close. The opener can be stopped during any portion of the opening or closing cycle by pressing either of the buttons. The next time the button is pressed, the opener will re-start the door in motion in the opposite direction.

OBSTRUCTION SENSING

When properly adjusted, the door will automatically reverse if it senses an obstruction during the closing cycle. This system will also stop the door if it hits an obstacle when opening.

SAFE-T-CYCLE™

This electronic system will reverse the door in 30 seconds or less if the door is unable to travel to the full closed position. This feature provides automatic reversing should other systems fail to operate and the door does not fully close.

SAFE-T-SIGNAL™

Lights will flash whenever Safety Reverse or Safe-T-Cycle has been activated.

FORCE ADJUSTMENTS

Independent OPEN and CLOSE dials allow you to select the minimum required opening and closing force.

EMERGENCY RELEASE

Your door opener is equipped with an emergency release device. In the event of a power failure, pull the knob on the pull cord down and slightly to the back (away from door) allowing the disconnect to latch. This will allow you to manually open or close the door. When power has been restored, gently pull the disconnect cord, releasing the traveler detent, then press either the transmitter or pushbutton. The opener will automatically reconnect.

SAFE-T-MONITOR™

A dynamic obstruction detection device that continuously monitors the amount of force required to move the garage door, and automatically adjusts the obstruction detection level in addition to the homeowner adjustable force levels. This SAFETY SYSTEM adds the additional level of protection indicating our commitment to safe garage door operation.

CONTROL CONNECTIONS

All opener models are provided with screw terminals for the attachment of a wall mounted pushbutton or four-function wall console. The console includes a pushbutton, worklight switch, vacation switch, and pedestrian light. Some models are provided with a pushbutton only, but ALL MODELS can be connected to the four-function wall console which is sold separately.

Specifications

Voltage Required: 120 Volts a.c.
60 cycle
Single Phase

A grounded, three (3) hole electrical outlet is required.

Motor Specs: Permanent Split Capacitor -Internal
Automatic Over load Reset

Current Required: 7 AMPS

Overload Protection: The motor is equipped with an automatic thermal over load device. Should the motor become over heated, the over load device will render the opener inoperative. Simply wait approximately 5 to 10 minutes for the motor to cool.

Opener Length: 10 Feet - 8 Inches
From end of tube assembly to rear of opener power unit.

Minimum Head Room Required: 2 Inches (Tracked Doors)
6 Inches (Trackless Doors)

Average Door Speed: 6 Inches per second

Maximum Door Size: 1/4 H.P.:
16 Ft. Wide / 7 Ft. High
1/3 H.P. or 1/2 H.P.:
18 Ft. Wide / 7 1/2 Ft. High

Door & Opener Terminology



WARNING: This garage door opener is intended for use on one of the types of doors shown below **ONLY**. It is **UNSAFE** to attempt installation on any other type of door or moving mechanism.

Use the illustrations on this page to determine the major components of your garage door. It is suggested that before you begin with assembly, you review the mounting procedure outlined on page 11. This will help you plan out, ahead of time, a means of securing the power unit.

ONE-PIECE TRACKED DOORS

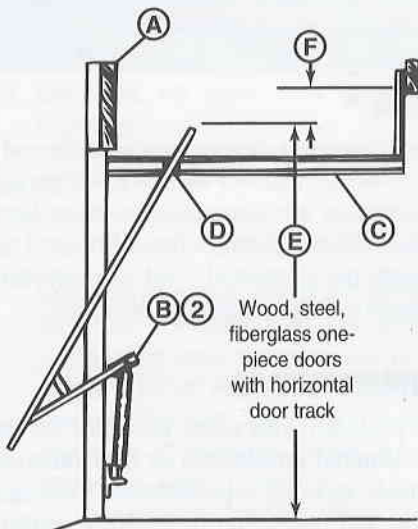

Wood, steel, fiberglass one-piece doors with horizontal door track

SECTIONAL TRACKED DOORS

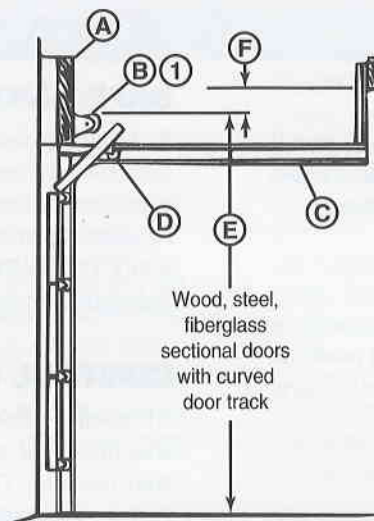

Wood, steel, fiberglass sectional doors with curved door track

TRACKLESS-TYPE DOORS

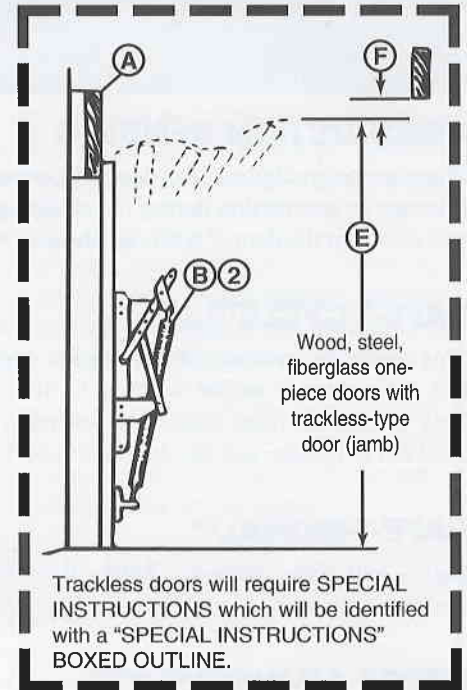

Wood, steel, fiberglass one-piece doors with trackless-type door (jamb)

Trackless doors will require **SPECIAL INSTRUCTIONS** which will be identified with a "SPECIAL INSTRUCTIONS" BOXED OUTLINE.

- (A) DOOR HEADER – The wood or metal beam positioned horizontally across the top of the garage doorway.
- (B) DOOR SPRING – Springs used to balance the door. B1 – Torsion spring, B2 – Extension spring.
- (C) DOOR TRACKS - Metal guides to allow the door to travel a straight path. Not used on trackless doors.
- (D) DOOR ROLLERS - Attached to the door and follow inside the door tracks. Not used on trackless doors.
- (E) HIGH-RISE - The highest point the top of the door reaches when opening.
- (F) HEAD ROOM - Area between high rise of door or the door spring and the bottom of rafters or finished ceilings. Do not attempt assembly with less than 2 inches of head room.

To become more familiar with your new GARAGE DOOR OPENER, please take time to study the following illustration of the completed unit and terminology. It will help you in the assembly and installation.

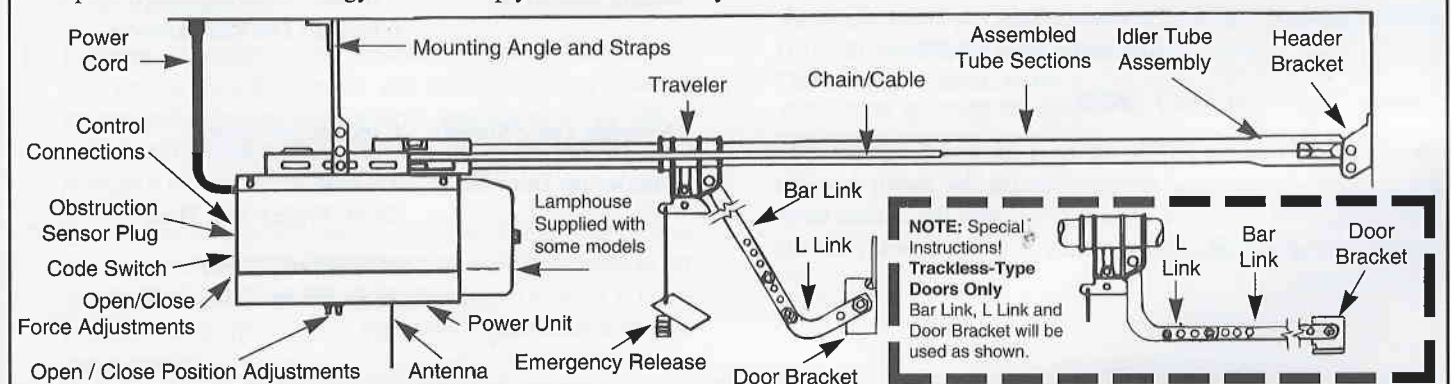

Components & Tools

Carefully inspect your new garage door opener for any possible damage and/or shortage of parts. Separate all parts, fasteners and accessories as called out below. Do not attempt installation if parts are damaged or missing.

DO NOT RUN OPENER UNTIL INSTRUCTED.

SEQUENCE OF OPERATION MAY CHANGE AND CAUSE FAULTY OPERATION!!

Major Components

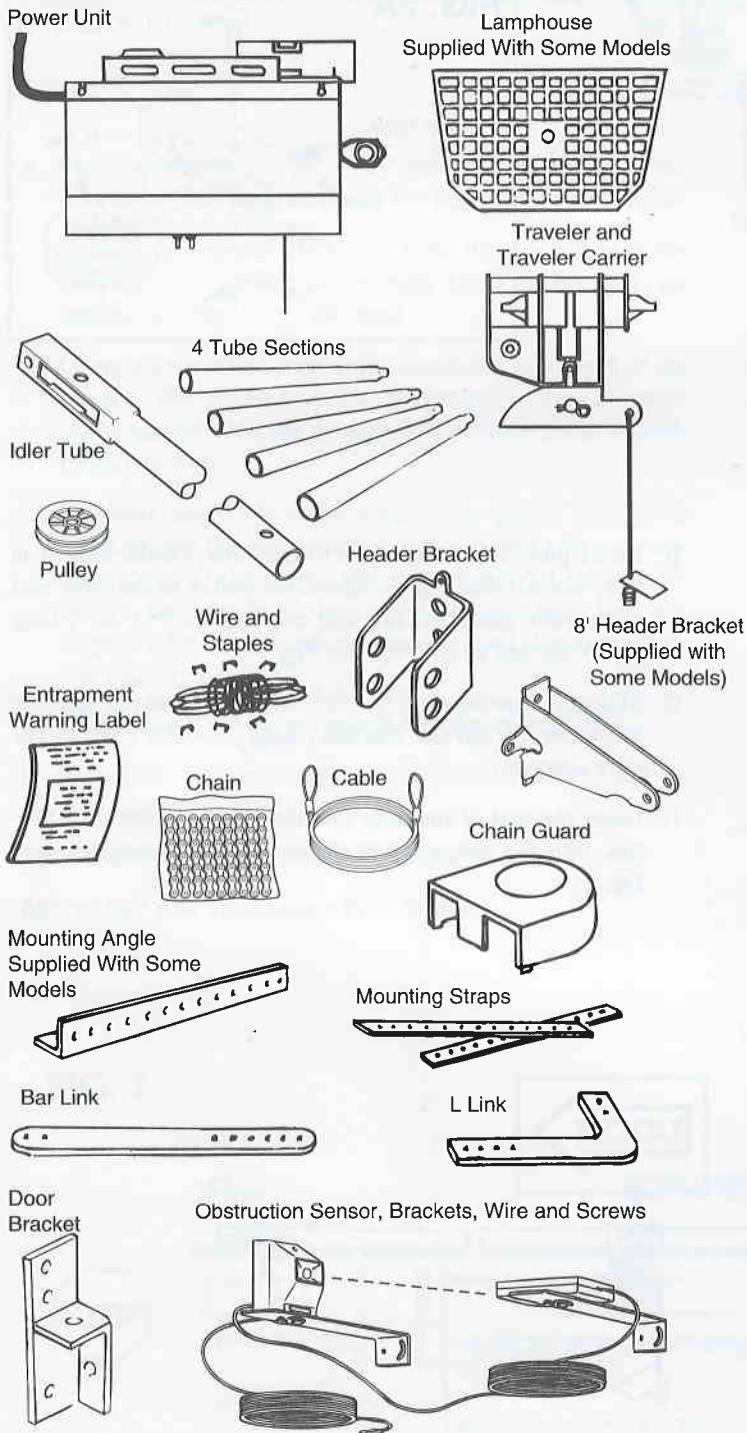

Accessories

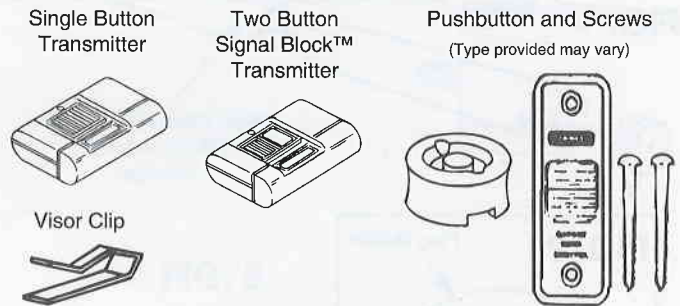

Fasteners

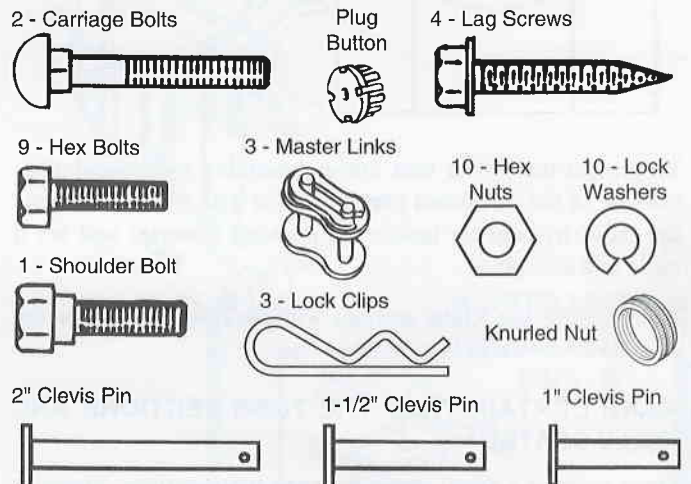

Tools Required Boxes

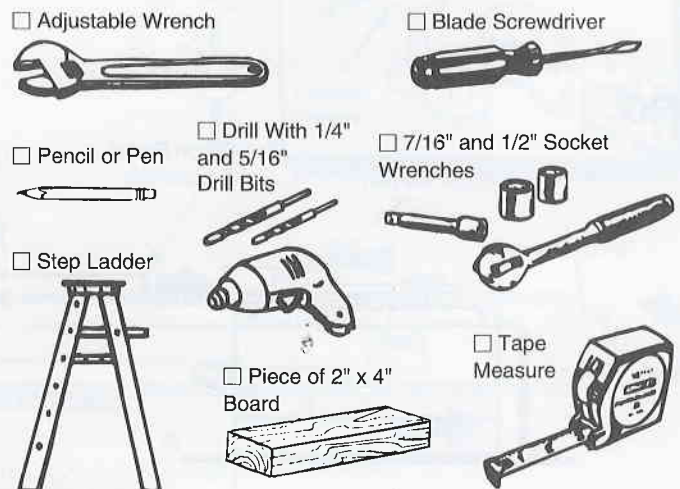

Assembly

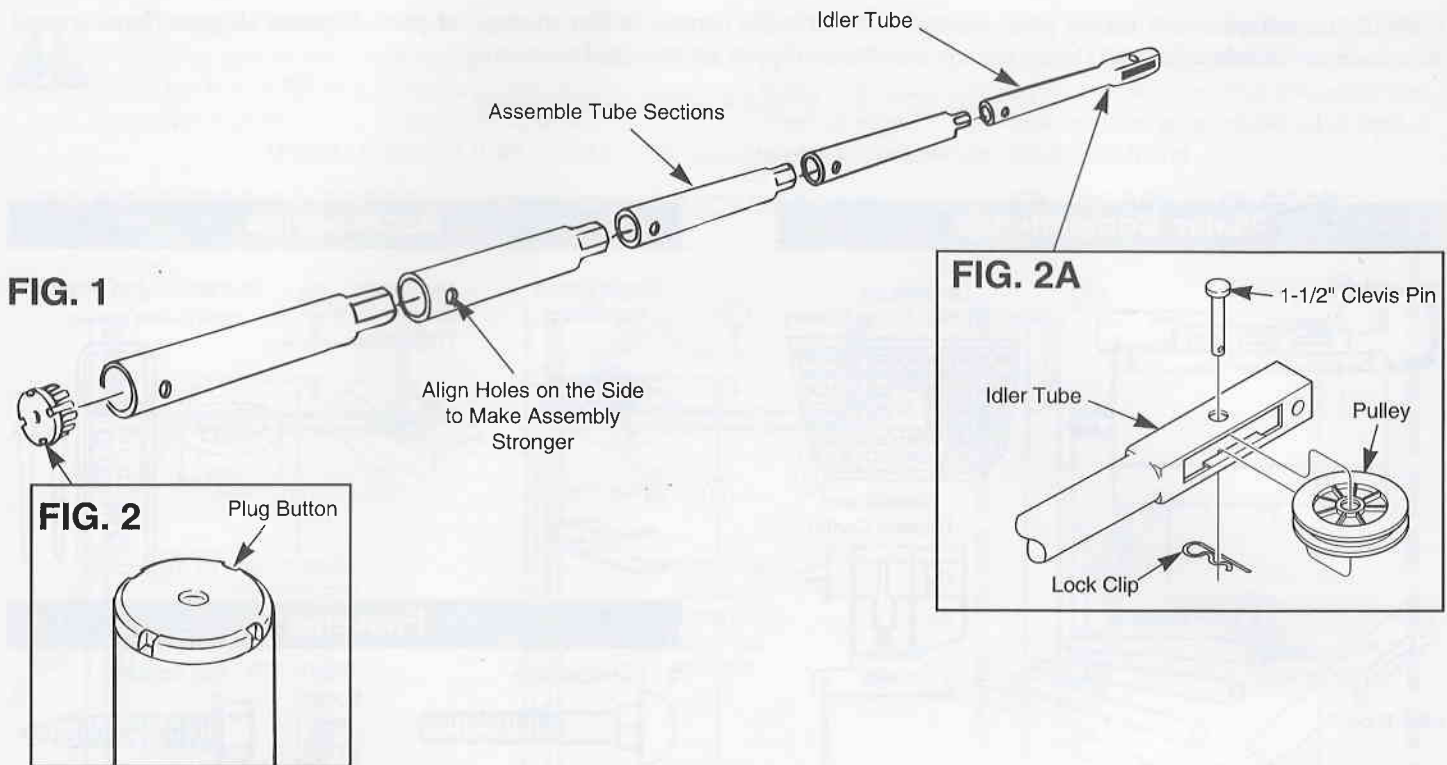

To protect the power unit during assembly and installation, use one of the cardboard panels packed with the unit. Locate the radio transmitter inside the packing material and set it aside in a safe place.

A. Assemble the 5 tube sections with the holes aligned on the side as shown in Fig. 1.

MAKE CERTAIN THAT THE TUBE SECTIONS ARE FULLY SEATED

There may be a small space between tube sections, however the "End To End" assembled length must be 118-1/4" (or less). (You may need to gently tap them together.)

B. Insert plug button into end of the tube, (make sure it is fully seated). See Fig. 2. Attach the pulley to the other end of the tube using the one and one half inch (1 1/2") long clevis pin and a lock clip. See Fig. 2A.

C. Slide the traveler onto the tube assembly making sure the arrow on the traveler marked (**DOOR**) points towards the idler assembly.

D. Insert the end of the tube assembly that has the plug button, into the tube support on top of the power unit. See Fig. 3.

FIG. 3

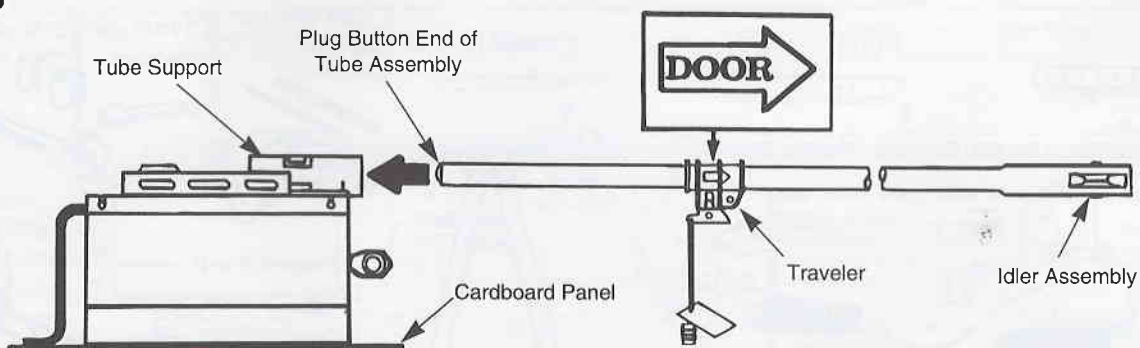

Assembly (continued)

FIG. 4

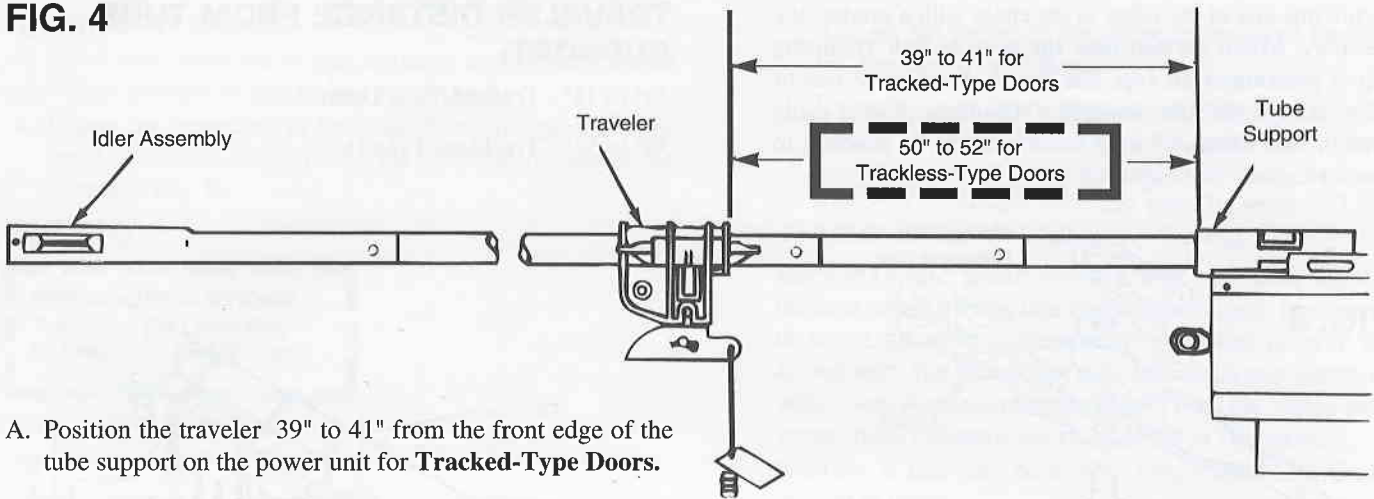

A. Position the traveler 39" to 41" from the front edge of the tube support on the power unit for **Tracked-Type Doors**.

Position the traveler 50" to 52" from the front edge of the tube support on the power unit for **Trackless-Type Doors**. See Fig. 4.

B. Using a master link assembly, secure the loose end of the chain to the traveler carrier, as shown in Figs. 5 and 6. **Make certain that the master link retaining clip is positioned on top.**

C. Carefully unroll the chain towards the power unit. Loop chain around drive sprocket on top of power unit and continue to unroll chain until you get to the end. Check to **BE SURE** the traveler is the correct distance from the tube support edge. If not, reloop chain around drive sprocket. See Fig. 7.

STOP! READ STEP A ON PAGE 8 BEFORE PROCEEDING.

IT IS VERY IMPORTANT THAT THE TRAVELER IS POSITIONED CORRECTLY.

39" TO 41" FOR TRACKED-TYPE DOORS

50" TO 52" FOR TRACKLESS-TYPE DOORS

FIG. 5

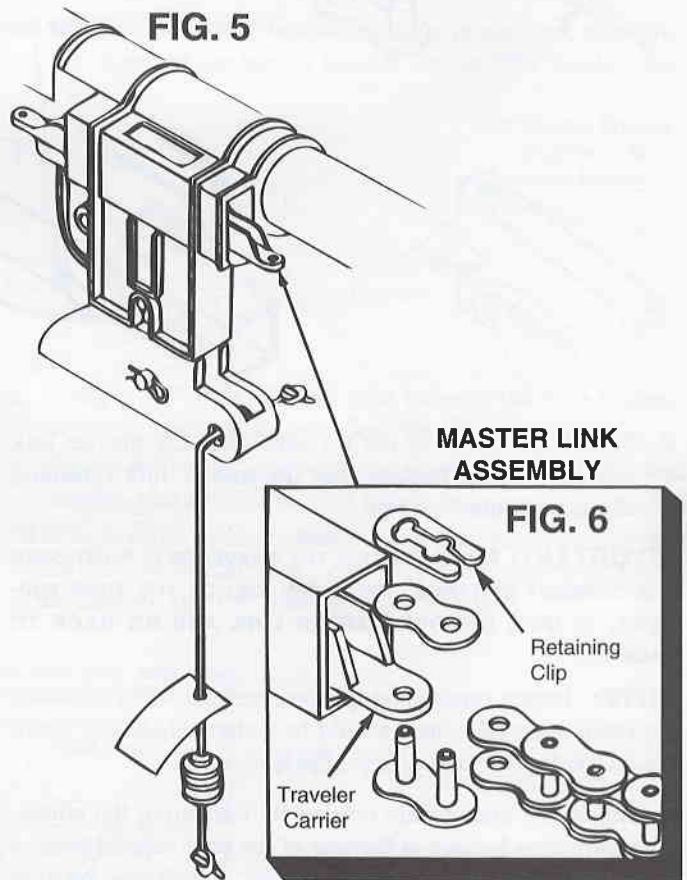
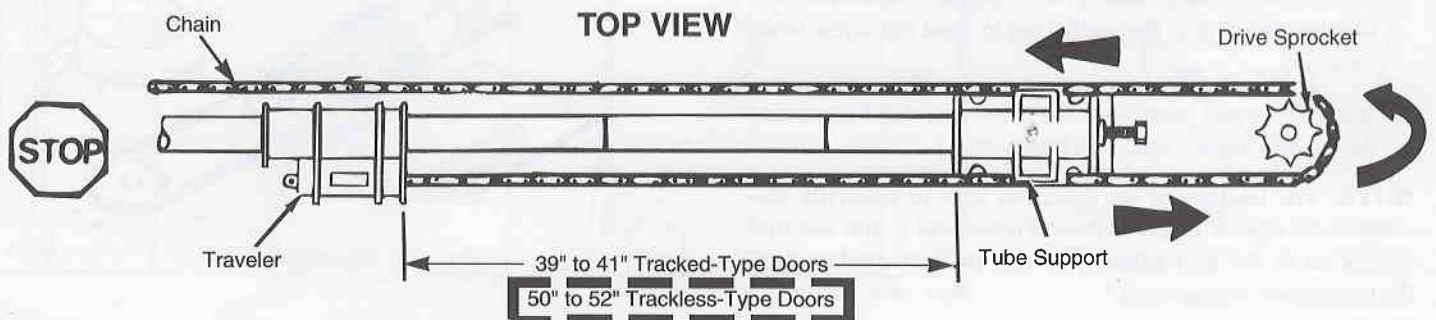
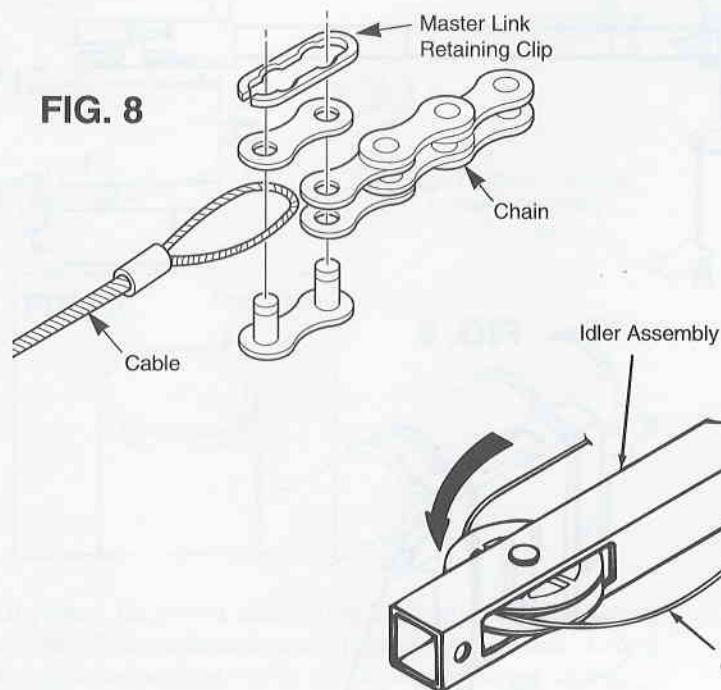

FIG. 7



Assembly (continued)

- A. Secure one end of the cable to the chain with a master link assembly. **Make certain that the master link retaining clip is positioned on top.** See Fig. 8. Feed loose end of cable through the idler assembly. Continue pulling cable through idler assembly until loose end can be attached to traveler carrier. See Fig. 8A.



TRAVELER DISTANCE FROM TUBE SUPPORT:

39" to 41" - Tracked-Type Doors

50" to 52" - Trackless-Type Doors

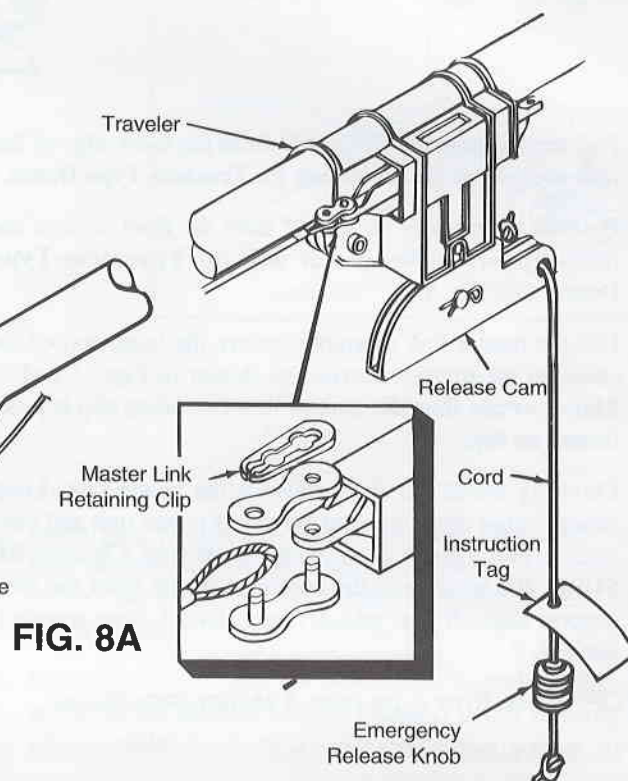

- B. Secure the cable to the traveler with the master link assembly. **Make certain that the master link retaining clip is positioned on top.**

IMPORTANT: MAKE CERTAIN THE TRAVELER IS POSITIONED THE CORRECT DISTANCE FROM THE END OF THE TUBE SUPPORT. IF NOT, REMOVE MASTER LINK AND GO BACK TO PAGE 7.

NOTE: Before proceeding, please note that when adjusting the chain and cable, there should be a slight chain sag, about 1/2 inch below the mid-point of the tube.

- C. Adjust the chain/cable tension by tightening the adjustment screw located at the rear of the tube support using a 7/16" socket wrench or screwdriver. (Clockwise rotation will tighten the chain/cable, counterclockwise will loosen). See Fig. 9. Be careful not to bend the screw when adjusting.

- D. Install the chain guard over the drive sprocket by pressing down until its tabs snap into frame.

NOTE: The instruction tag describes how to manually disconnect the opener from the door. Please read it now because further on in the instructions you will be instructed to "pull the emergency release cord."

FIG. 9

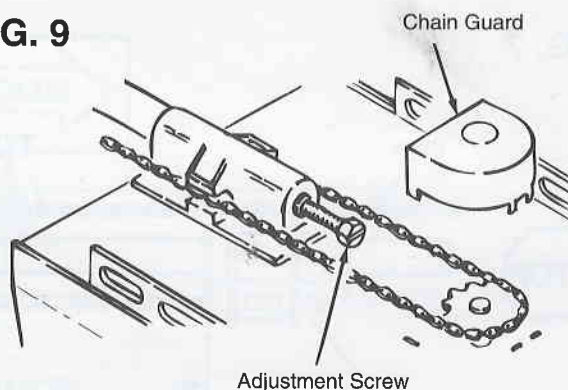

Installation

IMPORTANT! IT IS CRITICAL THAT YOU IDENTIFY WHAT TYPE OF DOOR YOU HAVE AS IT WILL MAKE A DIFFERENCE IN THE WAY YOUR OPENER IS INSTALLED, SEE PAGE 4.

A. Locate the centerline of the door. Mark the centerline of the door on the header above the door and the top of the door. See Fig. 10.

FIG. 10

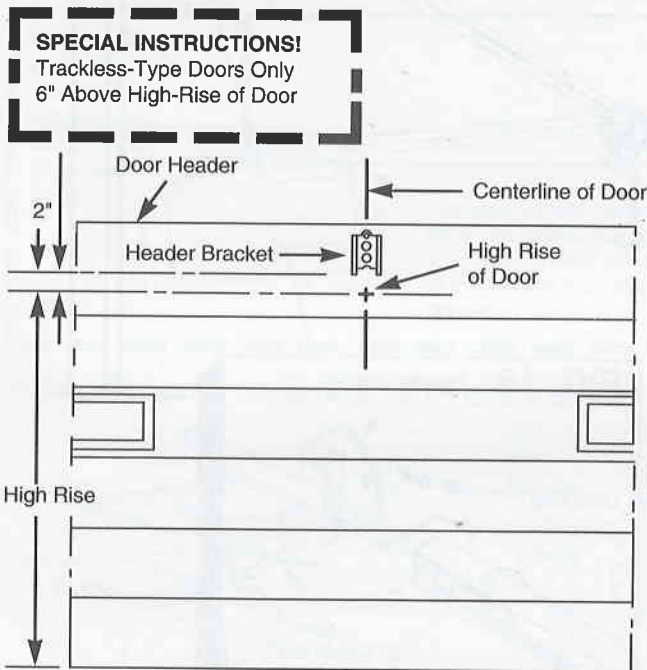

B. Slowly raise the door. When it reaches its **high-rise** point (highest distance off the ground when door is opening), place a support (prop) under the door to hold it at that position. Measure the distance from the floor to the top edge of door. See Fig. 11. Remove support and lower door.

C. Add **two (2) inches** to the distance measured for high-rise for **Tracked-Type Doors**.

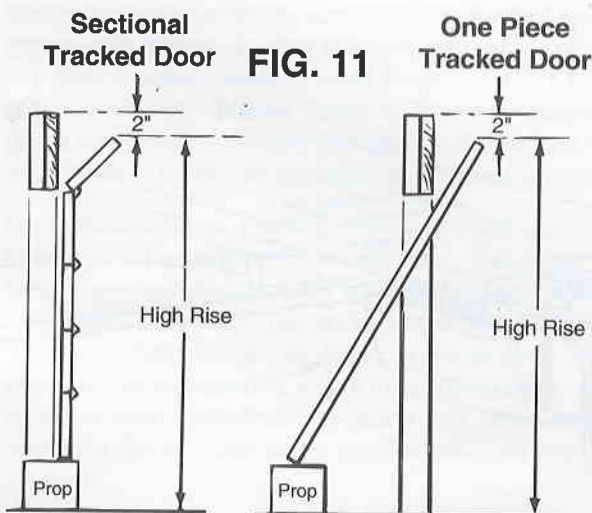
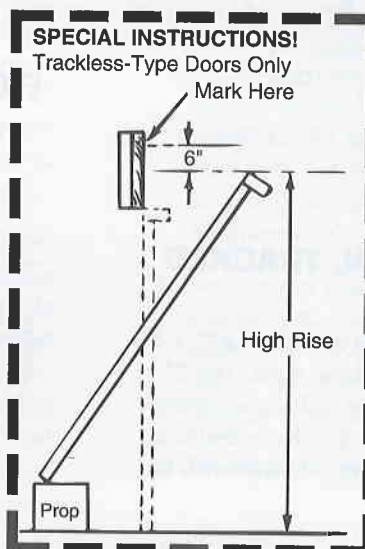

FIG. 11



Add **six (6) inches** to the distance measured for high-rise for **Trackless-Type Doors**.

Using this new figure, measure up from floor to bottom of bracket and mark that point on the door header. Locate the header bracket at that point and directly on the centerline mark. (The header bracket may be mounted higher, but do not mount any lower.) See Fig. 11.

IMPORTANT: SOME MODELS ARE SUPPLIED WITH AN 8' HEADER BRACKET FOR USE ON 8' HIGH DOORS. IF YOUR MODEL IS SUPPLIED WITH THIS BRACKET, PLEASE LOCATE IT NOW ALONG WITH THE 8' HEADER BRACKET MOUNTING INSTRUCTIONS WHICH ARE PACKAGED SEPARATELY. FOLLOW THESE INSTRUCTIONS, THEN CONTINUE ON TO PAGE 10 IN THE MANUAL.

NOTE: A nail may be used to temporarily hold the header bracket in place.

D. Holding the header bracket securely in position, **mark** the two holes of the header bracket on the door header. See Fig. 12.

FIG. 12

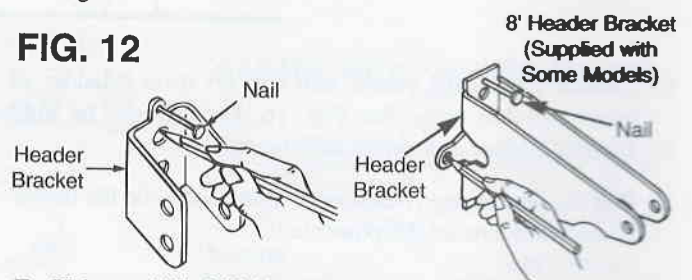

E. Using a 1/4" drill bit, drill pilot holes in the door header, using the marks as a guide. See Fig. 13.

F. Secure the header bracket to the door header with **two lag screws**. Make sure bracket is tightly secured.

NOTE: In some types of garages, there may be a **steel channel** across the door header. If this channel is there, **drill 5/16" holes** in the channel, and 1/4" holes in the door header.

FIG. 13

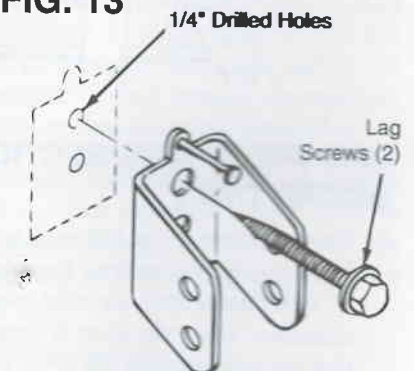

Installation (continued)

A. Place the power unit on the floor and raise the idler assembly up to the header bracket. See Fig. 14.

B. Using the 2" clevis pin and a lock clip, secure the idler assembly to the header bracket. See Fig. 15.

NOTE: The header bracket is designed with an additional positioning hole if height adjustment is necessary. It can also be mounted upside down for further adjustment.

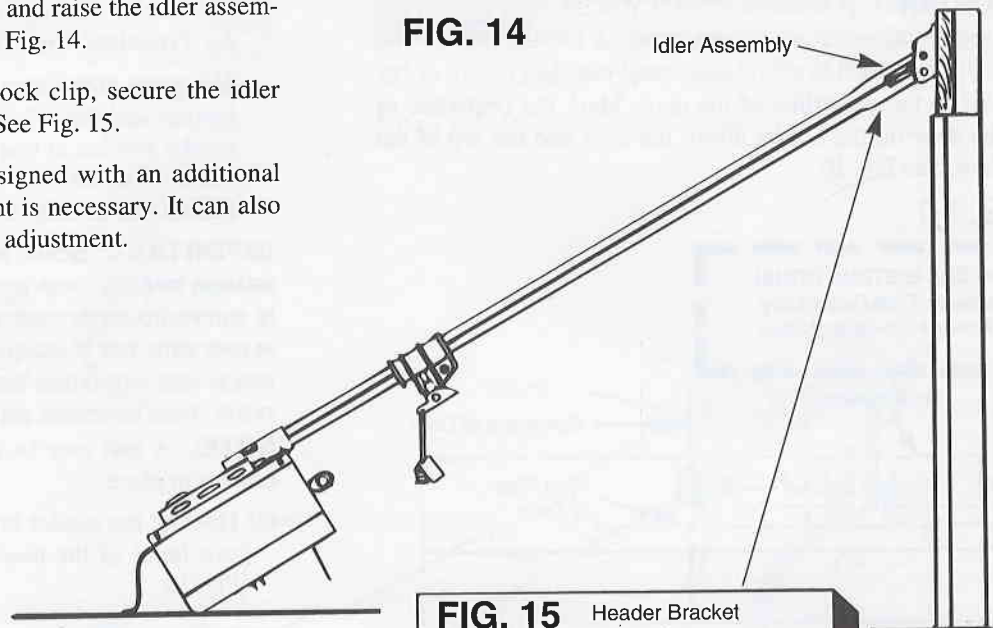

C. Carefully raise the power unit and set it on a ladder or other suitable prop. See Fig. 16. Unit should be high enough to clear door when fully opened.

D. Pull the emergency release cord down and slide the traveler assembly toward the power unit.

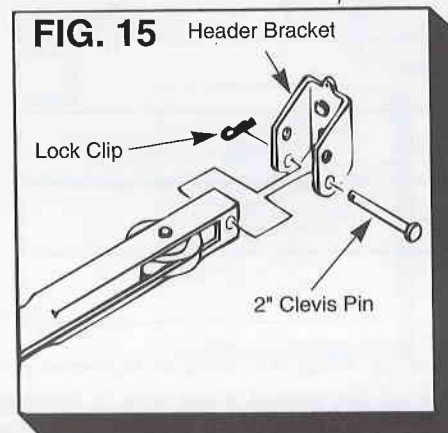

FIG. 16

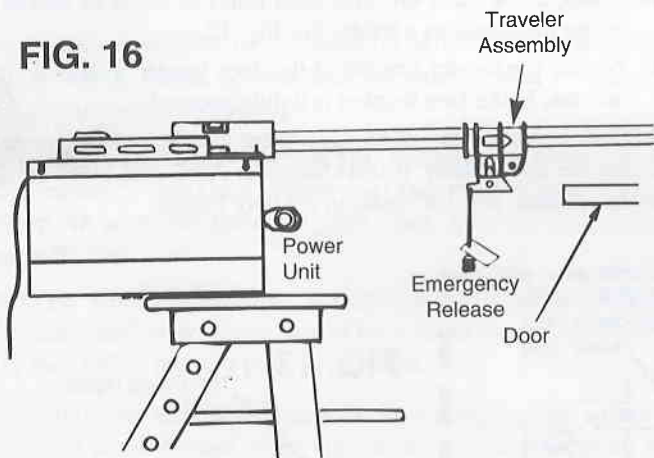
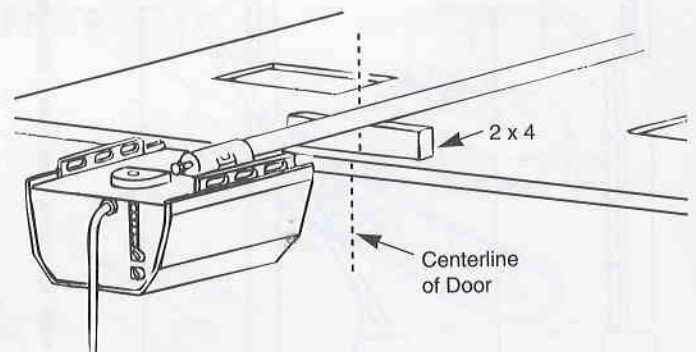

FIG. 17



ONE PIECE AND SECTIONAL TRACKED DOORS ONLY

E. Raise the door to the full open position and place a 2" x 4" board (on edge) between the tube and the door. The 2" x 4" will ensure that the tube assembly will have enough clearance when the door is opening. Set the operator so that the tube rests on the 2" x 4" directly in line with the center of the door. See Fig. 17.

Installation (continued)

FIG. 18

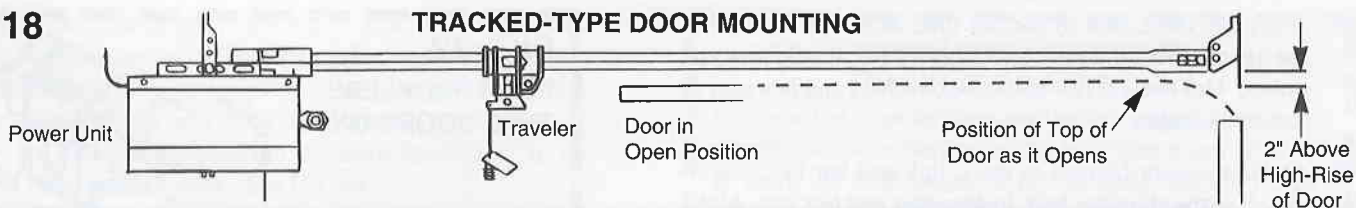

FIG. 19

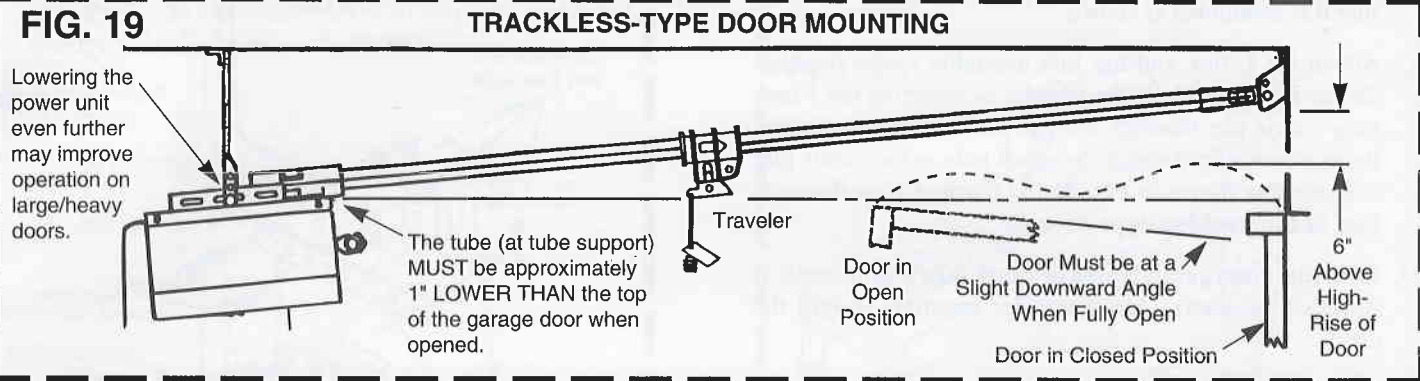
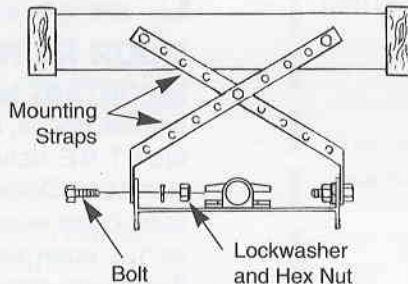
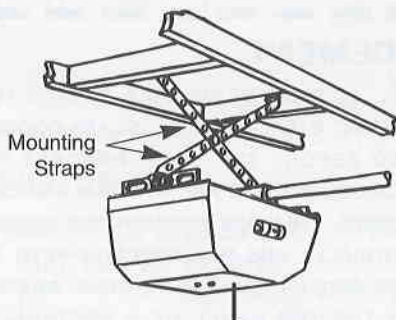
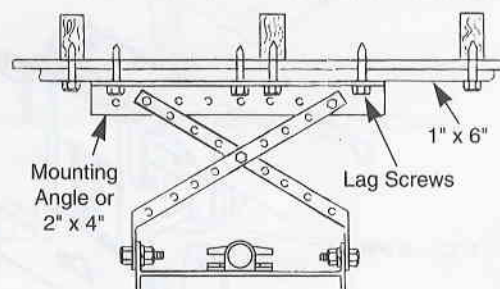

FIG. 20

GARAGE WITH OPEN BEAMS



GARAGE WITH FINISHED CEILING



SECURING POWER HEAD

General Information: Mounting instructions for the power unit must, of necessity, be somewhat general in nature due to the many different ceiling designs found in various residential and geographical areas. Custom-designed garages may have a finished ceiling of gypsum, sheet board, or finished tongue and groove style lumber. In other instances, unfinished ceiling types will have exposed overhead wood beams, 2" x 4", or 2" x 6" rafters, joists, etc. Due to these construction variances, every power unit installation could be slightly different with different circumstances arising for each specific mounting application.

For finished ceilings, a section of 1" x 6" board can be secured to span the distance between ceiling rafters. The power unit can then be mounted directly to the board using the mounting angle and straps. If necessary, lag screws, longer than those furnished with the opener, or expansion bolts can also be used. Basic carpentry procedures, coupled with a little pre-planning, should be all that is required to mount the power unit. If needed, a local carpenter can be contacted to provide whatever assistance is required.



The main concern in mounting the power unit is that the installation be securely mounted for operational strength, rigidity and safety. Mounting straps can be easily bent and cut to conform to whatever configuration that may be required. See Figs 18 and 19.

- A. Mount the power unit to an overhead beam or ceiling. See Fig. 20 for typical mounting suggestions. For mounting, use lag screws, hex head bolts, hex nuts and lockwashers. (Lag screws are for use in overhead wood beams or ceilings; hex head bolts and nuts are for mounting straps and angle.) The adjustable wrench and 1/2" socket wrench are required. Additional 2 x 4's may be needed for proper installation.
- B. Once power head is securely mounted, remove all supports and ladders. Operate the door manually several times to ensure that the door travels freely and does not contact any part of the tubes. Top edge of door should clear the tube sections by at least one inch.

Do not allow door to hit the traveler.

Installation (continued)

- A. Assemble the L link to the bar link, as shown in **Fig. 21 for tracked-type doors** and **Fig. 22 for trackless-type doors**. Use two (2) hex bolts, lockwashers and hex nuts to secure the links.
- B. Attach the door bracket to the L link and bar link assembly. Use the shoulder bolt, lockwasher and hex nut. Make sure it is assembled as shown.
- C. Attach the L link and bar link assembly to the traveler. Secure the assembly to the traveler by inserting the 1 inch long clevis pin through the traveler and the assembly. Insert a lock clip through the small hole in the clevis pin. Assemble as shown in **Fig. 21 for tracked-type doors** or **Fig. 22 for trackless-type doors**.
- D. Pull the emergency release cord down and cock it (towards the door). Move traveler assembly toward the door.

FIG. 21 TRACKED-TYPE DOOR MOUNTING

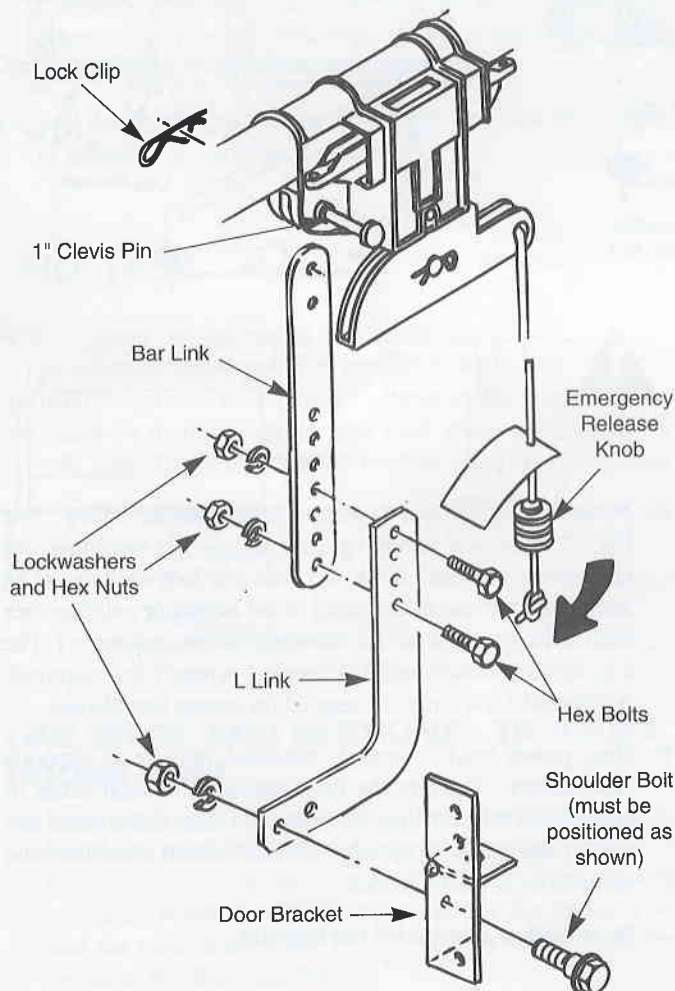
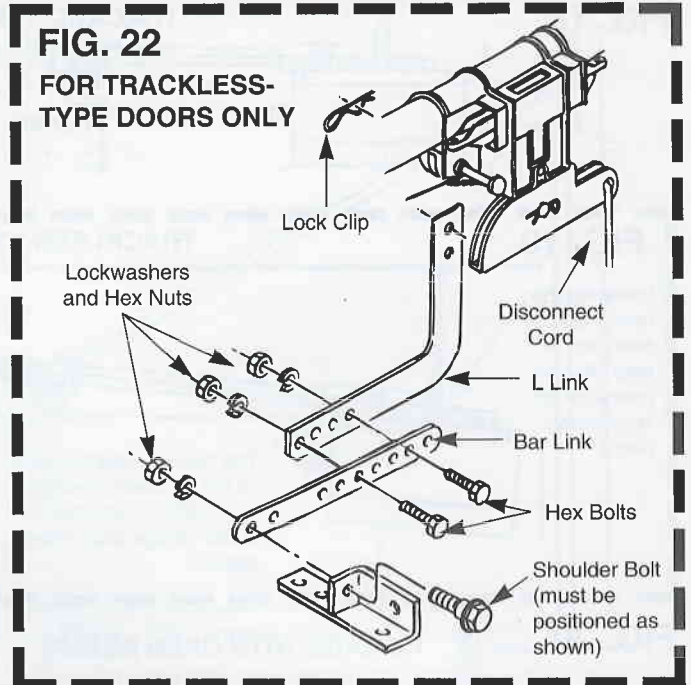

FIG. 22 FOR TRACKLESS-TYPE DOORS ONLY



DOOR REINFORCEMENT

IMPORTANT NOTICE: TO PREVENT POSSIBLE DAMAGE TO GARAGE DOORS, LIGHTWEIGHT STEEL AND FIBERGLASS DOORS **MUST BE REINFORCED BEFORE THE DOOR BRACKET IS INSTALLED.** DOOR REINFORCEMENT KITS ARE AVAILABLE FROM SOME DOOR MANUFACTURERS. ALWAYS SUPPORT THE INSIDE OF THE DOOR BOTH VERTICALLY AND HORIZONTALLY WITH A 2X4 BOARD, CHANNEL, OR ANGLE IRON. THE VERTICAL BRACE MUST COVER AT LEAST THE TOP PANEL OF A SECTIONAL DOOR, AND THE HORIZONTAL BRACE MUST BE AT LEAST SIX (6) FEET LONG. SEE FIG. 23.

FAILURE TO PROPERLY BRACE YOUR DOOR PRIOR TO THE INSTALLATION OF OPENER MAY RESULT IN SEVERE DOOR DAMAGE. THE ADDITION OF THESE BRACES MAY AFFECT THE BALANCE OF THE DOOR. AFTER INSTALLATION, CHECK FOR PROPER MANUAL OPERATION AND HAVE THE DOOR REBALANCED IF NECESSARY.

FIG. 23

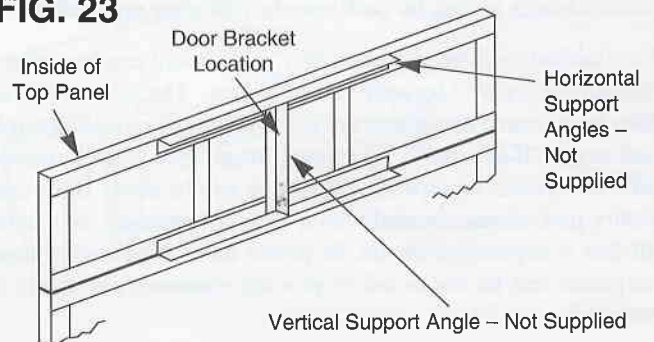

Installation (continued)

E. Position the door bracket near top of door, as close as possible to the center of the top door roller and mark the two door bracket holes on the door. On sectional doors, the door rollers should be 3" to 6" from the top of the door. If they are not, simply position the door bracket 3" to 6" below the top of the door. See Fig. 24.

F. Move the traveler back and drill two (2) 5/16" holes through the door at the marked hole location.

FIG. 24

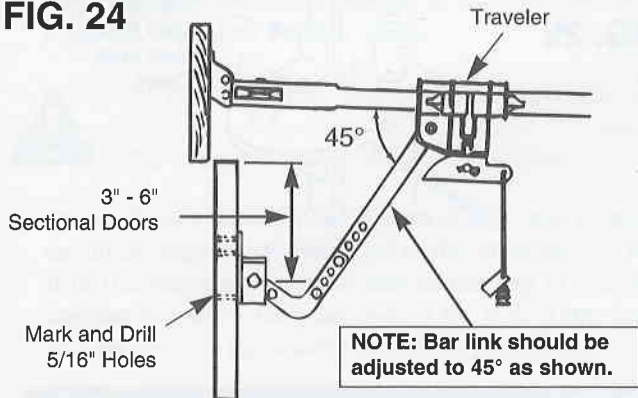

G. Move traveler assembly toward the door and attach door bracket to door. Use hex bolts or carriage bolts to securely fasten bracket to door. See Fig. 25.

FIG. 25

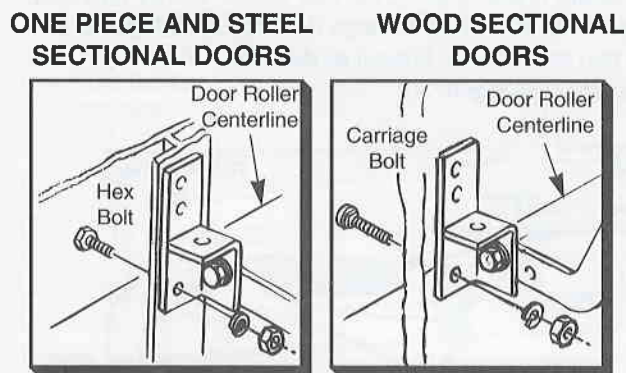

MAKE SURE door linkage is straight when door bracket is secured to door.

H. Manually open the door to assure unobstructed movement. **NOTE:** When door is fully open the traveler should be at least 8" away from the power unit. If not, shorten the door linkage as required.

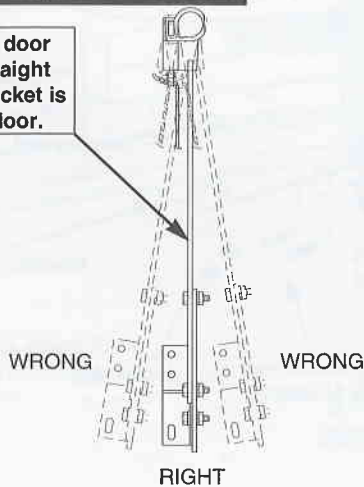

SPECIAL INSTRUCTIONS! TRACKLESS DOORS ONLY

Position the door bracket on the top edge of the door, directly on the centerline of the door. Use a pen or pencil to mark the hole locations on the door. Drill (2) 5/16" holes through the door at the marked hole locations. See Fig. 26.

FIG. 26

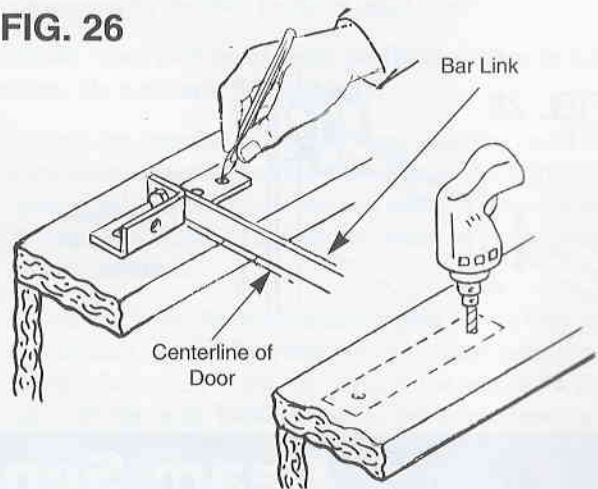

Use hex bolts or carriage bolts to securely fasten bracket to door. See Fig. 27.

FIG. 27

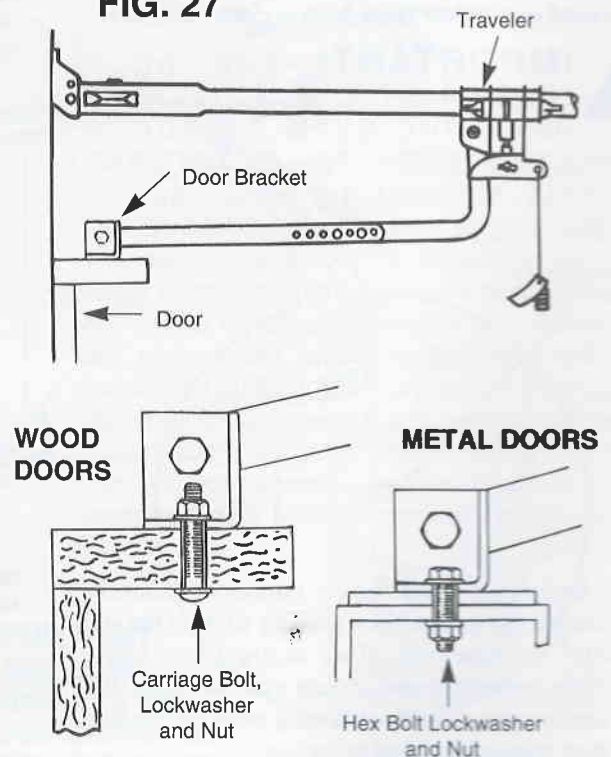

Lock Removal



IMPORTANT: THE DOOR OPENER PROVIDES FOR POSITIVE CLOSING OF THE DOOR. ALL EXISTING DOOR LOCKS MUST BE MADE INOPERATIVE. IF EXISTING DOOR LOCKS ARE LOCKED WHILE TRYING TO USE THE OPENER, DAMAGE TO OPENER AND DOOR COULD RESULT.

Pin or screw the existing lock mechanism in the "open" (unlocked) position. If necessary, the catch latches may be

repositioned or the complete lock assembly may be removed. Because of the many styles of door locks, the illustrations show only two of the more common types.



IMPORTANT: IT IS IMPORTANT THAT ALL ROPES AND CORDS, THAT COULD CAUSE ENTANGLEMENT, BE REMOVED FROM THE DOOR.

FIG. 28

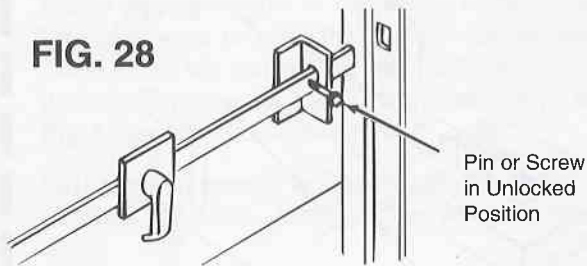
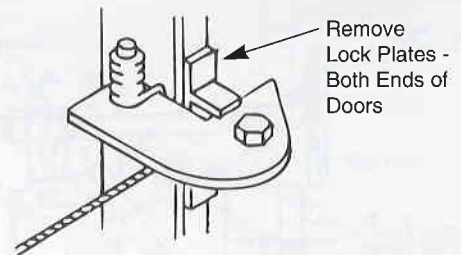

FIG. 29



Beam Sensor Mounting

Your garage door opener is supplied with an infrared beam sensor that sends an invisible beam of light from the sending unit to the receiving unit across the pathway of the door. **Please read and follow these instructions carefully.**



IMPORTANT: THE DOOR OPENER WILL NOT OPERATE UNTIL THE BEAM SENSOR IS CONNECTED TO THE POWER UNIT AND PROPERLY ALIGNED. THE INVISIBLE BEAM OF LIGHT MUST NOT BE OBSTRUCTED, OTHERWISE, THE DOOR CAN BE CLOSED BY MAINTAINING CONSTANT PRESSURE ON THE WALL-MOUNTED PUSHBUTTON ONLY. THE TRANSMITTER CANNOT BE USED TO CLOSE THE DOOR. THE DOOR CAN BE OPENED USING EITHER THE HAND-HELD TRANSMITTER OR WALL-MOUNTED PUSHBUTTON EVEN IF THE BEAM IS NOT ALIGNED OR CONNECTED TO THE POWER UNIT. PULL EMERGENCY RELEASE CORD TO DISCONNECT DOOR FROM OPENER, THEN MANUALLY CLOSE GARAGE DOOR BEFORE CONTINUING.

Before beginning beam sensor mounting, identify which side of the garage door opening (if any) the sun is "likely" to shine into. Since sunlight may cause undesirable operation, you should plan to mount the small sending unit (not the receiving unit) on the side of the door opening exposed to the sun.

- A. Begin by attaching the sending and receiving units to the mounting brackets using the four thumb screws provided. The thumb screws go through the bracket and thread into the two holes on the bottom of the units. Do not tighten at this time. See Figure 30.

FIG. 30

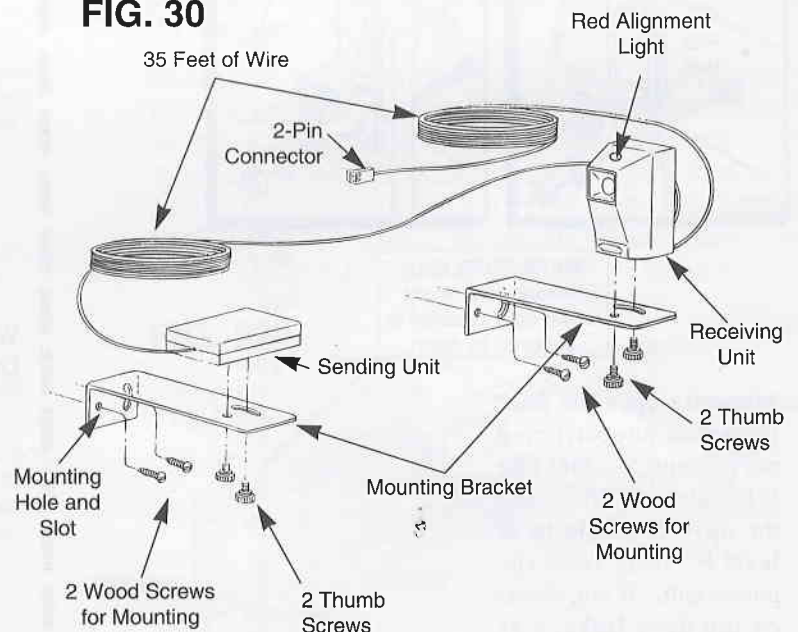

Beam Sensor Mounting (continued)

- B. Select a mounting position 2 to 4 inches above the floor. If possible the sending and receiving units should be mounted at least 12 inches inside the door opening to minimize any interference by the sun. See Figure 31.
- C. Using the wood screws provided, attach the receiving unit to the wall. In some installations it may be necessary to attach wooden spacers to the wall to insure that the beam will clear the door tracks. Expansion bolts (not supplied) may be required to attach brackets to walls constructed of materials other than wood or gypsum.



The beam must be mounted as close to the door track or inside edge of the door as possible to offer maximum entrapment protection.

- D. Do not tighten the mounting screws at this time. Carefully uncoil the wire that is connected to the small sending unit. Run the wires up the wall across the top of the door opening and down the other side of the wall. Temporarily tack the wires in place using the staples provided.

DO NOT USE A STAPLE GUN.

Be sure to run the wires in a location where they will not interfere with the operation of the door.

- E. If wires must be lengthened, use wire nuts or a suitable connector. One wire has a white stripe. Be sure to connect white wire to white wire.
- F. Mount the sending unit the same way you mounted the receiving unit with the wood screws provided, but approximately one (1) inch higher. Make sure the sending and receiving units point toward each other and are not obstructed by the door tracks or other objects.

Carefully loop and secure any additional wire in a safe location. Do not staple through wire.

- G. Uncoil the remaining loop of wire with the small 2-pin connector attached to one end. Route the wire up the garage wall across the ceiling and down to the back of the power unit. Temporarily tack the wires in place using the staples provided.
- H. Locate the 2-pin obstruction sensor plug on the back of the power unit. Carefully plug the connector onto the two metal tabs located inside the notch at the rear of the power unit. **Make sure locking tab is properly inserted as shown.** See Figure 32. Leave a small loop of wire that attaches to the rear of the door opener power unit. This is to ensure that the connector will not pull off the tabs if the power unit moves during operation.

FIG. 31

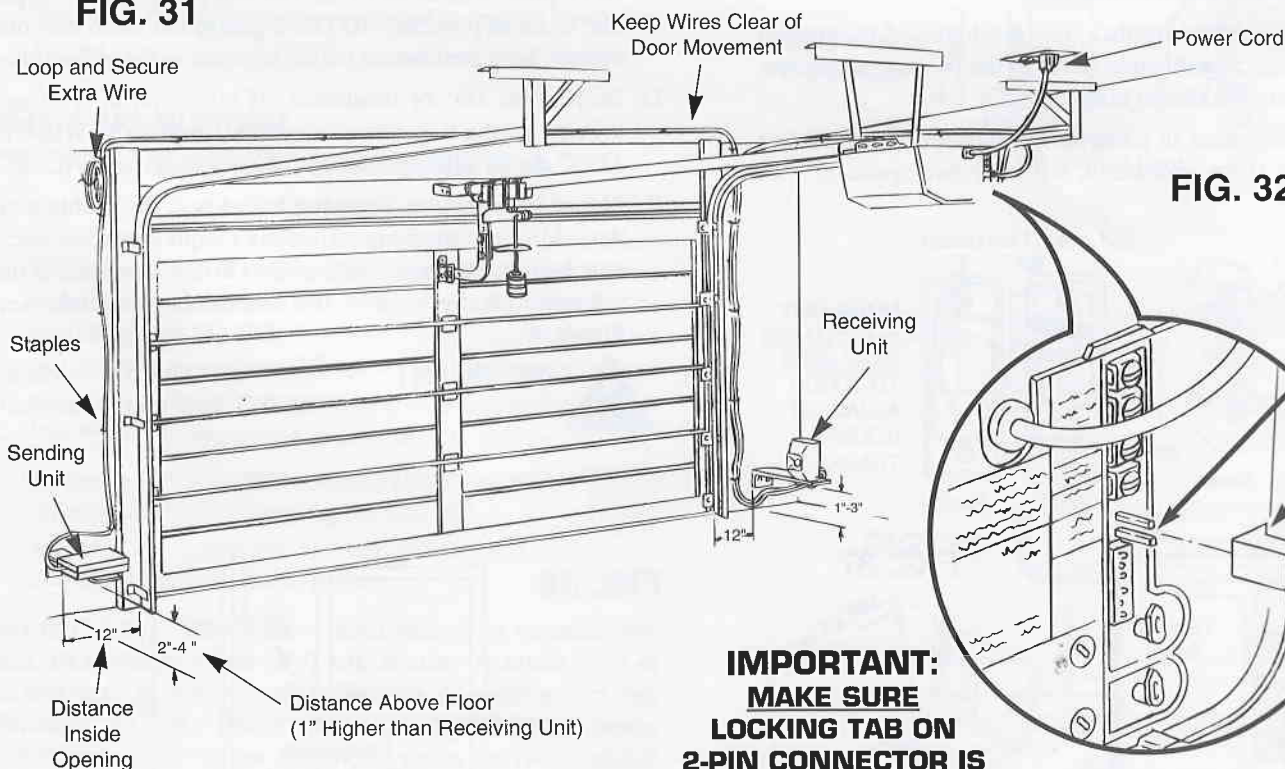

**IMPORTANT:
MAKE SURE
LOCKING TAB ON
2-PIN CONNECTOR IS
INSERTED AS SHOWN.**

Lighting

SINGLE LIGHT SOCKET MODELS

Install one 100 watt light bulb into the single light socket. See Fig. 33.

DUAL LIGHT SOCKET MODELS

Install two 100 watt light bulbs into the dual lamp socket. Install lamphouse using the knurled nut to secure it. See Fig. 34.

NOTE: The maximum total wattage must not be more than 200 watts. It is suggested that rough service bulbs be used.

AUTOMATIC LIGHT OPERATION

ALL MODELS: The lights will come on when the door opens or closes, and stay on for 4-1/2 minutes, then automatically turn off.

SPECIAL LIGHT FEATURE "SAFE-T-SIGNAL"

Whenever any of the opener's safety features are activated, the lights on the opener will flash until the next push of either the transmitter or pushbutton.

FIG. 33

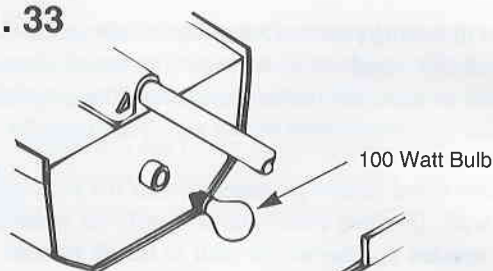
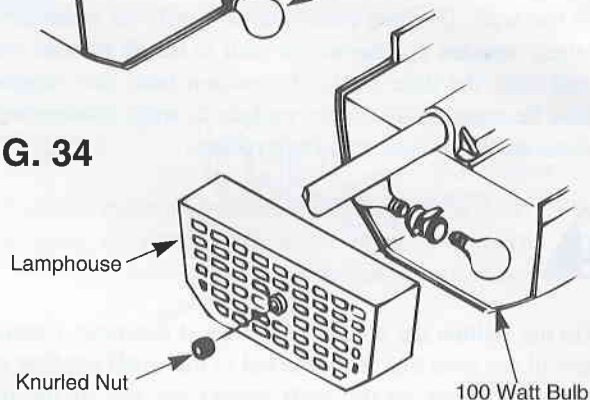

FIG. 34



Pushbutton Installation

NOTE: If opener is supplied with a four-function wall console, the pushbuttons shown below **WILL NOT** be used. Please refer to those instructions now (packaged separately), then return to this page.

- Strip about 1/4" of insulation off each end of pushbutton wire. Connect pushbutton wires to the two screws on rear of pushbutton as shown in Figure 35.
- Locate pushbutton in a convenient location at least 5 feet above the floor and attach with the two wood screws provided.

FIG. 35

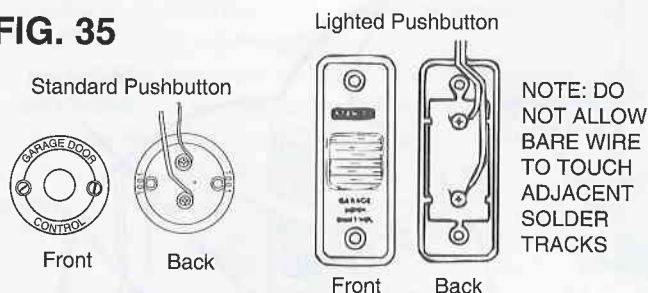

FIG. 36

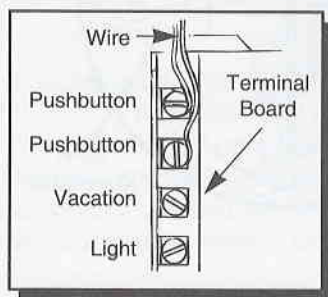
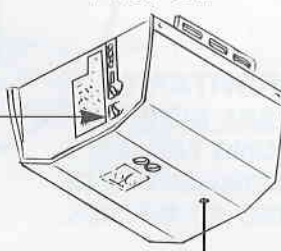

FIG. 37



- Run wire from pushbutton to power unit. Use staples provided to secure wire. **DO NOT USE A STAPLE GUN.** Do **NOT** staple through wires. This will cause a short. Do **NOT** place wire close to the 120 volt power wires. Separate as far as possible. **NOTE:** If garage has more than one opener, keep pushbutton wiring separate as far as possible.
- Strip about 1/4" of insulation off other end of wire and connect to the two screw terminals labeled "PUSHBUTTON" at rear of the power unit. See Figures 36 and 37.
- Mount **Entrapment Warning Label** near the pushbutton. An additional mechanical means (staples, screws, etc.) may be required to secure this label to some surfaces if the adhesive on the back of the label does not stick. See Figure 38.



IMPORTANT: MOUNT THE PUSHBUTTON HIGHER THAN A CHILD CAN REACH AND IN A LOCATION WHERE THE DOOR IS EASILY VISIBLE.



NEVER PASS UNDER A MOVING GARAGE DOOR.

FIG. 38

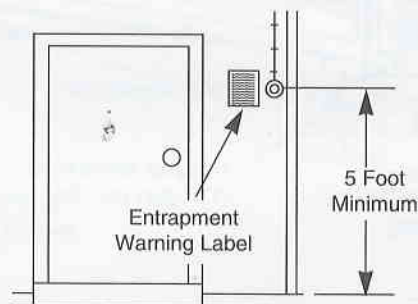

Radio Coding Instructions



WARNING: KEEP TRANSMITTER OUT OF REACH OF CHILDREN.

ALL MODELS

A. Locate the bank of digital code switches on rear panel of opener. With a pencil or pen, flip any combination of switches to set your own personal code. See Figs. 39 and 40.

NOTE: All odd numbered switches are factory set to the OPEN position. All even numbered switches are set to the CLOSED position.

IMPORTANT: Do not leave the code switches in the "AS PURCHASED" position or set all switches in the same position.

B. Squeeze transmitter case as shown in Fig. 41 and remove side panel. Side panel may be removed more easily by twisting a nickel (5¢) in coin slot on bottom of case.

C. With a pencil or pen, set the code switches in the identical positions (pattern) that you set the code switches on the rear panel of the opener. See Fig. 42.

D. Replace access panel on transmitter.

NOTE: Small red light on top of transmitter indicates when your transmitter is sending signal. If the light does not come on when transmitter button is pressed, check for a dead battery.

E. Straighten the radio antenna and point it straight down. See Fig. 43.

THE TWO-BUTTON "SIGNAL BLOCK™" TRANSMITTER

A. If your door opener was supplied with a two-button, hand-held Signal Block™ transmitter, the buttons are marked DOOR and SECURE. The DOOR button is used to control your door, and the SECURE button is used to lock out or disable use of the DOOR button on the transmitter. This feature adds an additional level of security to your opener, preventing others from opening your door with a single-button transmitter.

B. To activate the "SECURE FEATURE," your garage door must be fully closed. Pressing the SECURE button once will activate (turn on) the system; pressing it again will deactivate (turn off) this system.

IMPORTANT: USING YOUR WALL-MOUNTED PUSHBUTTON WILL DEACTIVATE (TURN OFF) THE SECURE FEATURE IF IT IS ACTIVATED. IF YOUR DOOR OPENER IS CONNECTED TO THE STANLEY "FOUR-FUNCTION WALL CONSOLE," USING THE CONTROL BUTTON OR VACATION SWITCH ON THE CONSOLE WILL DEACTIVATE (TURN OFF) THE SECURE FEATURE.

FCC Radio Usage Limitations

CAUTION: The garage door operator and all accessory radio equipment has been designed to Federal Communications Standards for Part 15 radio devices. Operation of this device is subject to the following conditions: (1) This device may not cause harmful interference; (2) This device must accept any interference that may be received, including interference that may cause undesired operation; (3) Changes or modifications not expressly approved by Stanley Home Automation, Division of The Stanley Works, could void the authority of users to operate this equipment.

FIG. 39

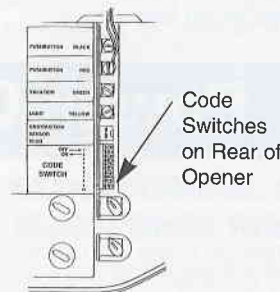

FIG. 40

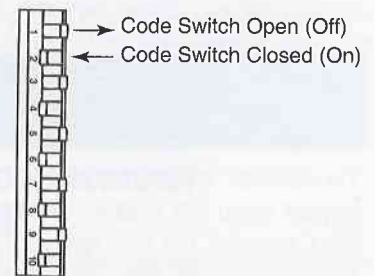

FIG. 41

Single-Button Transmitter

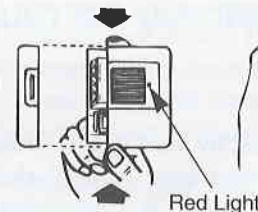
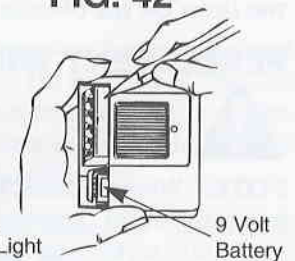

FIG. 42



Two-Button Signal Block™ Transmitter

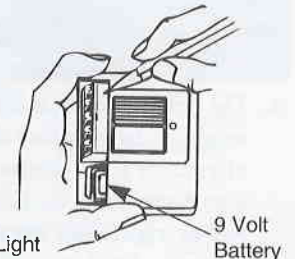
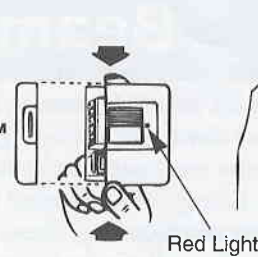
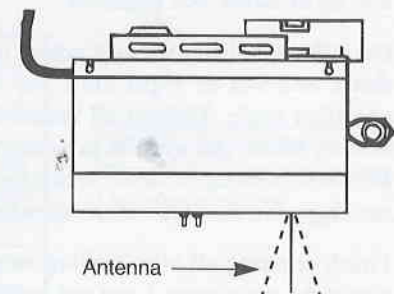

FIG. 43



Important Safety Instructions



WARNING: BEFORE CONNECTING POWER, PLEASE REVIEW THESE IMPORTANT SAFETY INSTRUCTIONS. THEY ARE DESIGNED TO REDUCE THE RISK OF SEVERE INJURY OR DEATH. PLEASE READ AND FOLLOW ALL INSTRUCTIONS CAREFULLY.

- A. NEVER LET CHILDREN OPERATE, OR PLAY WITH DOOR CONTROLS. KEEP REMOTE CONTROL AWAY FROM CHILDREN.
- B. ALWAYS KEEP MOVING DOOR IN SIGHT AND AWAY FROM PEOPLE AND OBJECTS UNTIL IT IS COMPLETELY CLOSED. NO ONE SHOULD CROSS THE PATH OF THE MOVING DOOR.
- C. TEST DOOR OPENER MONTHLY. THE GARAGE DOOR **MUST** REVERSE ON CONTACT WITH A 1-1/2 INCH OBJECT (OR A 2 X 4 BOARD LAID FLAT) ON THE FLOOR. IF ADJUSTING

EITHER THE FORCE OR THE LIMIT OF TRAVEL, RETEST THE DOOR OPENER. FAILURE TO ADJUST THE OPENER PROPERLY MAY CAUSE SEVERE INJURY OR DEATH.

- D. IF POSSIBLE, USE THE EMERGENCY RELEASE ONLY WHEN THE DOOR IS CLOSED. USE CAUTION WHEN USING THIS RELEASE WITH THE DOOR OPEN. WEAK OR BROKEN SPRINGS MAY CAUSE THE DOOR TO FALL RAPIDLY, CAUSING INJURY OR DEATH.
- E. KEEP GARAGE DOORS PROPERLY BALANCED. SEE OWNERS MANUAL. AN IMPROPERLY BALANCED DOOR COULD CAUSE SEVERE INJURY. HAVE A QUALIFIED SERVICE PERSON MAKE REPAIRS TO CABLES, SPRING ASSEMBLIES AND OTHER HARDWARE.
- F. **SAVE THESE INSTRUCTIONS.**

Power Connection

TO REDUCE THE RISK OF ELECTRIC SHOCK, CONNECT THE POWER CORD ONLY TO A PROPERLY GROUNDED 3 PRONG 120 VOLT OUTLET. DO NOT USE AN EXTENSION CORD OR CHANGE THE PLUG IN ANY WAY. IF THE PLUG DOES NOT FIT INTO THE OUTLET, CONTACT A QUALIFIED ELECTRICIAN TO INSTALL THE PROPER OUTLET. AS SOON AS POWER IS APPLIED TO THE UNIT, THE LIGHT ON THE OPENER SHOULD BLINK ONCE.

PERMANENT WIRING INSTRUCTIONS



DISCONNECT POWER AT FUSE BOX BEFORE PROCEEDING.

NOTE: Where required by local codes, opener must be permanently wired. Services of a licensed electrician can be obtained to perform the above permanent wiring.

- A. Remove cover from power unit.
- B. Remove electrical power cord from opener and black plastic strain relief bushing. NOTE: Bushing can be removed by compressing with pliers and then pulling out.
- C. Attach white lead to silver colored terminal marked L1, black lead to brass colored terminal marked L2, and green grounding lead to ground screw using the external tooth cup washer located in accessory bag. Washer is required to properly retain the wire.
- D. Replace cover and switch power on at fuse box.

Beam Sensor Alignment

- A. The beam sensor can be aligned by moving the sending and receiving units **up or down** and **left or right** until the red alignment light on the receiving unit comes on. The two thumb screws on the bottom can be loosened to move the unit **left or right**, and the two mounting screws that fasten the mounting brackets to the wall can be loosened to move the unit **up or down**. See Figure 44.
- B. Once the red alignment light comes on, pivot the unit **up or down** and **left or right** until you find the center of the operating angle. **Tighten all thumb screws and mounting screws when the system is centered.** This will prevent possible operating problems which may occur if the system is not aligned in the center of the operating angle.
- C. Finish securing all wire making sure not to break or open any of the conductors. Loop and secure any extra wire.

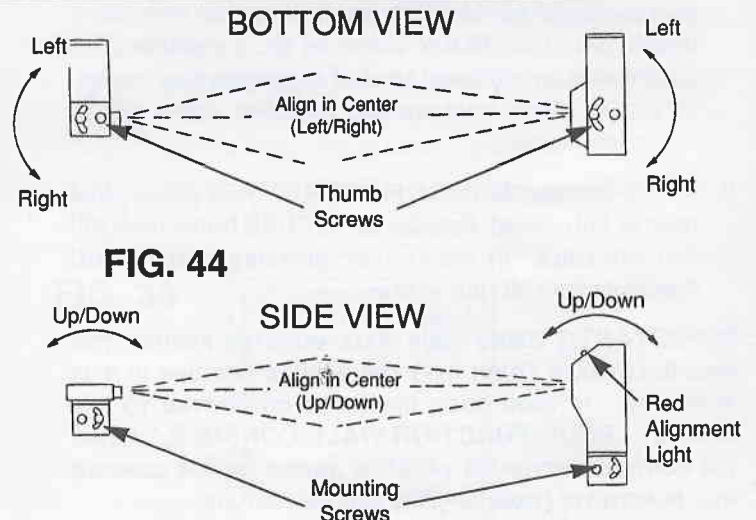

Adjustments

ENGAGE TRAVELER DETENT

- Pull the emergency release cord straight down and allow mechanism to engage in slot.
- Manually open door slowly until traveler engages with traveler carrier.



CAUTION: THE OPENER WILL OPERATE DURING THE FOLLOWING STEPS. INSURE NOTHING IS IN THE PATH OF DOOR BEFORE PROCEEDING.

NOTE: This operator is equipped with a thermal protector in the motor circuit. If during the following steps the unit shuts off and will not restart, wait 5-10 minutes for the motor to cool down, then continue adjustment.

- Push the transmitter button once. Keep the door pathway clear of obstructions. The door should begin to close and stop before reaching the floor. If it does not, refer to the radio coding instructions (page 17) of this manual then return to this section.
- If the door begins to close then reverses and opens with the lights on the opener blinking, either the beam sensor is not properly connected and aligned (page 18) or the **open** and **close force** adjustments must be increased.
- If a force is selected which is lower than what is required to move your door, the opener will reverse while closing or stop while opening with the lights flashing.
- If the door is closing and an object passes between the sending unit and receiving unit of the beam sensor, the door will reverse and open with the opener lights blinking.

OPEN AND CLOSE FORCE ADJUSTMENTS

- The open and close force adjustments located on the rear of the opener select the amount of force the power unit applies to open and close the garage door. See Fig. 45. **These dials must be turned slowly in small increments to insure the minimum amount of force is used to open and close your door.**

- Beginning at low, turn force dials (1/10 turn at a time) to increase door force until door can be cycled between the "factory set" open and close positions without the lights on the opener blinking. The door should move for approximately 6 seconds.

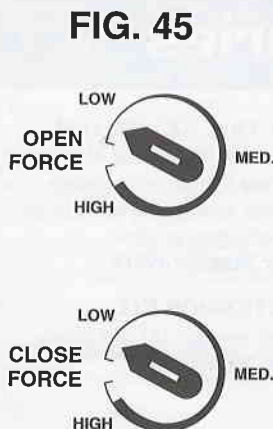

OBSTRUCTION TESTING

- Once the door can be cycled between the "factory set" open and close positions without the system either stopping or reversing with the opener lights blinking, activate the door in the closed direction. While it is closing extend your hands under the bottom edge of the door and try to stop it. (The use of gloves is suggested.) **Do not stand in pathway of door or block beam sensor.** The door should reverse off of your hands and begin to open with minimum force. If it does not reverse, or if the force is excessive, decrease the close force until a lower level is selected. Reference Fig. 47.
- Once the close force is properly adjusted, activate the door to open and try to stop it with your hands. **Do not put fingers between door sections.** The door should stop (not reverse) with minimum force otherwise the open force must be decreased until a lower force is selected.

CLOSE TRAVEL ADJUSTMENT (Small Black Knob)

- Push the transmitter button until the door closes and automatically stops before reaching the floor. Locate the small black close travel adjustment knob on the bottom of the power unit. See Fig 46.
- Slowly turn this knob in the direction of the arrow (more close travel) until the door moves. The door should "inch" its way closed. Repeat inching the door closed until it reaches the floor. Continue to turn the knob until the door is secure against the floor with the tube slightly bowed.
- If the door reverses off of the floor and opens turn the knob slightly (1/4 turn at a time) in the opposite direction of the arrow and cycle the door again until the door is securely closed without reversing off of the floor.

FIG. 46

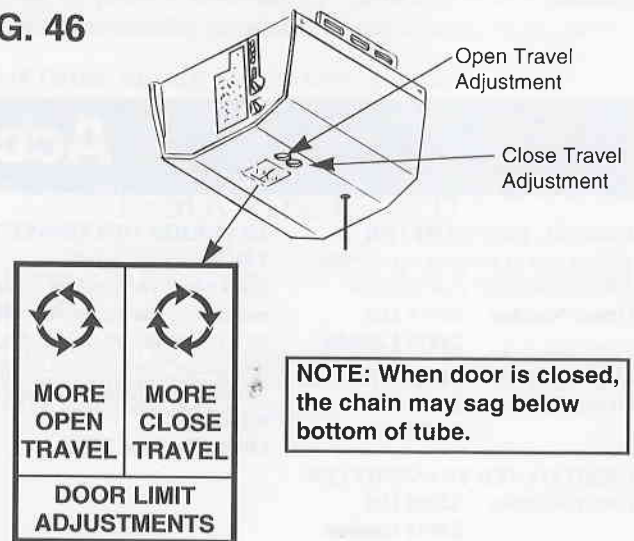

Adjustments (continued)

ENTRAPMENT TEST



WARNING: SEVERE DAMAGE TO DOOR, DOOR OPENER OR PERSON MAY OCCUR IF THE CLOSE FORCE ADJUSTMENT IS SET TOO HIGH FOR CONDUCTING THE FOLLOWING TEST. Some doors require additional reinforcement to prevent damage. Read "Door Reinforcement" section of this manual (page 12) before continuing.

- With the door open, place a 1-1/2 inch object (or a 2 x 4 board laid flat) under the door opening. Activate the door in closed direction. The door should contact the object then reverse and open. If the door simply stops and does not reverse, turn the black close travel adjustment knob 1/4 turn in the direction of the arrow (more close travel) and test again.
- Repeat this procedure until the door reverses off of the 1-1/2 inch object and opens but can be closed securely against the floor without reversing. See Fig. 47

FIG. 47

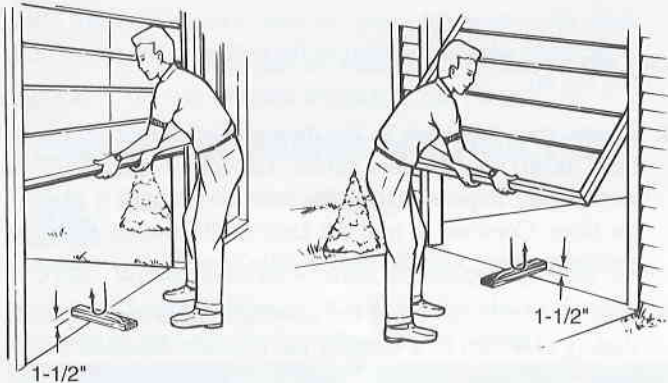

NOTE: If door fails to reverse off object, discontinue use and contact the Stanley Customer Service Department.

NOTE: The tube acts as a shock absorber during the opening and closing of your garage door. When the door is fully closed, there will be some tube bowing. This bowing minimizes the stress on the door and door hardware. See Fig. 48.

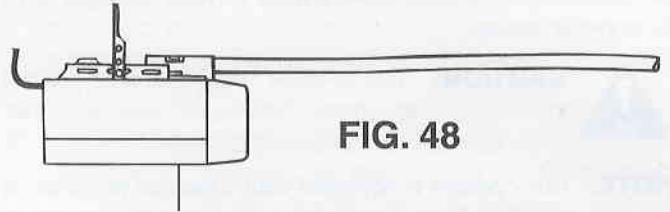

FIG. 48

OPEN TRAVEL ADJUSTMENT (Small White Knob)

- Activate power unit until the door opens and automatically stops. Locate the small white open travel adjustment knob on the bottom of the power unit. Slowly turn this knob in the direction of the arrow (more open travel). The door will "inch" its way open.
- Continue to turn this knob until the desired open position is selected. Do not force the door open any further than its natural open position. This may cause excessive strain on the door or door opener. Trackless doors should be at a slight downward angle when fully open. Reference Figure 19.

BEAM SENSOR TESTING

- Push the hand-held transmitter to close the door. While the door is closing, test the beam sensor by obstructing the invisible beam. When obstructed, the red alignment light on the receiving unit should turn off. The closing door should stop, pause two seconds, then reverse and begin opening. The lights on the door opener should flash.
- Obstructing the beam while the door is opening will have no effect.

THAT'S IT — YOU'RE DONE! Please take time to read the remaining pages and fill out the warranty registration card.

Accessories

DIGITAL TRANSMITTER

Allows you to program up to 1024 different personal code settings.

Order Number 24911 U.S.
24970 Canada

SIGNAL BLOCK TRANSMITTER

Order Number 24987 U.S.
24972 Canada

LIGHTMAKER TRANSMITTER

Order Number 24898 U.S.
24972 Canada

EXTERIOR DISCONNECT LOCK

Used when you have no separate entrance to the garage. Should there be a power failure, it will disconnect the opener from outside the garage, enabling you to operate your door manually.

Order Number 24714

ELECTRIC KEYSWITCH

Used when you are out of your car and want to enter your garage. By inserting a key and turning it, the door will open or close.

Order Number 49019

8' EXTENSION KIT

For use on eight (8) foot doors.

Order Number 24697

DIGITAL CODEKEY™ ENTRY

This unique, multi-code entry system with telephone-type pushbutton keyboard will allow you to open or close your door from outside the garage by pressing your personal code.

Order Number 24718

Troubleshooting: Problem/Solution

OPENER DOES NOT WORK

- A. Make sure power cord is plugged into a properly grounded 3 prong 120 volt outlet. Plug in a drill or other electrical tool to test for power.
- B. If opener has been cycled several times, the motor overload protector may be activated. Wait approximately 10 minutes for the motor to cool and then try again.
- C. If a four-function wall console is being used, make sure the vacation switch is in the "UNLOCKED" position.
- D. If door is severely out of balance, the opener may not be able to exert enough force to move it. Make sure all locks are removed. Pull the emergency disconnect cord to release the door from the opener. Check to see if the opener will operate if not connected to the door. If opener now operates review "Door Balance Test" section of this manual.

HAND-HELD TRANSMITTER DOES NOT WORK OR HAS SHORT RANGE

- A. Review the "Radio Coding" instructions in this manual. Someone else's radio controls may be interfering with yours. Try changing your code.
- B. The battery in your transmitter may be dead or weak. Replace it with a 9 volt battery of the same type.
- C. Try moving or coiling the antenna wire on the opener.
- D. CB radios, computer equipment, powerful communication signals, and other door openers may cause undesirable interference and shorten radio range.

PUSHBUTTON DOES NOT WORK

- A. Make sure the pushbutton wires are not touching each other at the rear of the opener or at the pushbutton.
- B. If the wires are not touching each other and the problem still exists, disconnect the wires from the back of the opener and "short" across the two pushbutton screws using a key or screwdriver. If opener now operates, the pushbutton wires are probably shorted or broken.

LIGHTS FLASHING ON OPENER

- A. This may be caused by activating the obstruction system that is controlled by the **open or close force adjustment** on the rear of the opener. If it requires more force to move the door than the opener can supply this system will activate. A common cause is a poorly operating door or an obstruction. Review "Door Balance Test" and "Open and Close Force Adjustments" in this manual.
- B. If the beam sensor is not aligned and working correctly, the door can only be closed by holding the wall-mounted pushbutton. The transmitter cannot be used to close the door. The light on the opener will flash and the door will reverse and open if button is not held until the door is fully closed.
- C. If something obstructs the door while closing, it will reverse and open - lights will flash. If something obstructs the door while opening, it will stop - lights will flash.

DOOR CLOSSES - THEN OPENS WHEN REACHING THE FLOOR

- A. Is there a rake handle, garden hose, snow, ice, etc. obstructing the door? Remove the obstruction then try closing the door again.
- B. Due to climatic conditions many concrete floors will heave or sink. Turn the (small black) **close travel adjustment** 1/4 turn opposite the direction of the arrow on the cover, then review the "Close Position" and "Entrapment" test instructions in this manual.

OPENER ACTIVATES BY ITSELF

- A. Somebody may be using the same radio code as you. **DO NOT** leave radio code switches in **factory set** position. Review "Radio Coding Instructions."

EXCESSIVE TUBE BOW

- A. Check to see that the powerhead is securely mounted and the door operates freely. Review "Door Balance Tests" in this manual. Is something obstructing the door?
- B. Review "Close Travel" and "Entrapment Test" sections in this manual.

LIGHT STAYS ON

- A. The light time delay on the opener will keep the light on for approximately 4 1/2 minutes after the system has been activated, then will turn it off automatically.
- B. If opener has a **worklight** switch (which is supplied only with a four-function wall console), slide switch to "OFF" position.
- C. If opener has a pedestrian light switch, (which is supplied only with a four-function wall console), the light will stay on for 4-1/2 minutes after the pedestrian door is opened.

NOT ENOUGH OPEN OR CLOSE TRAVEL ADJUSTMENT

- A. If you operated the power unit before it was completely installed or if you did not position the traveler the correct distance from the tube support, the limits and traveler may be out of synchronization.
- B. Turn off power, remove and relocate traveler by disconnecting chain from sprocket, re-assemble and try adjusting again.

SOMETHING BROKE - NEED ASSISTANCE?

Identify the part in this instruction manual (on the next page) then contact your local Stanley dealer or use the Stanley free help line:

1-800-521-5262

- A. Reference the proper pages in this manual for all adjustments and settings.
- B. If the problem has been located in the radio controls (other than batteries) return only the transmitters and the control board. **DO NOT return the complete opener.**

Parts List

Header Bracket
360.3088

NOT ALL PARTS SHOWN ARE SUPPLIED

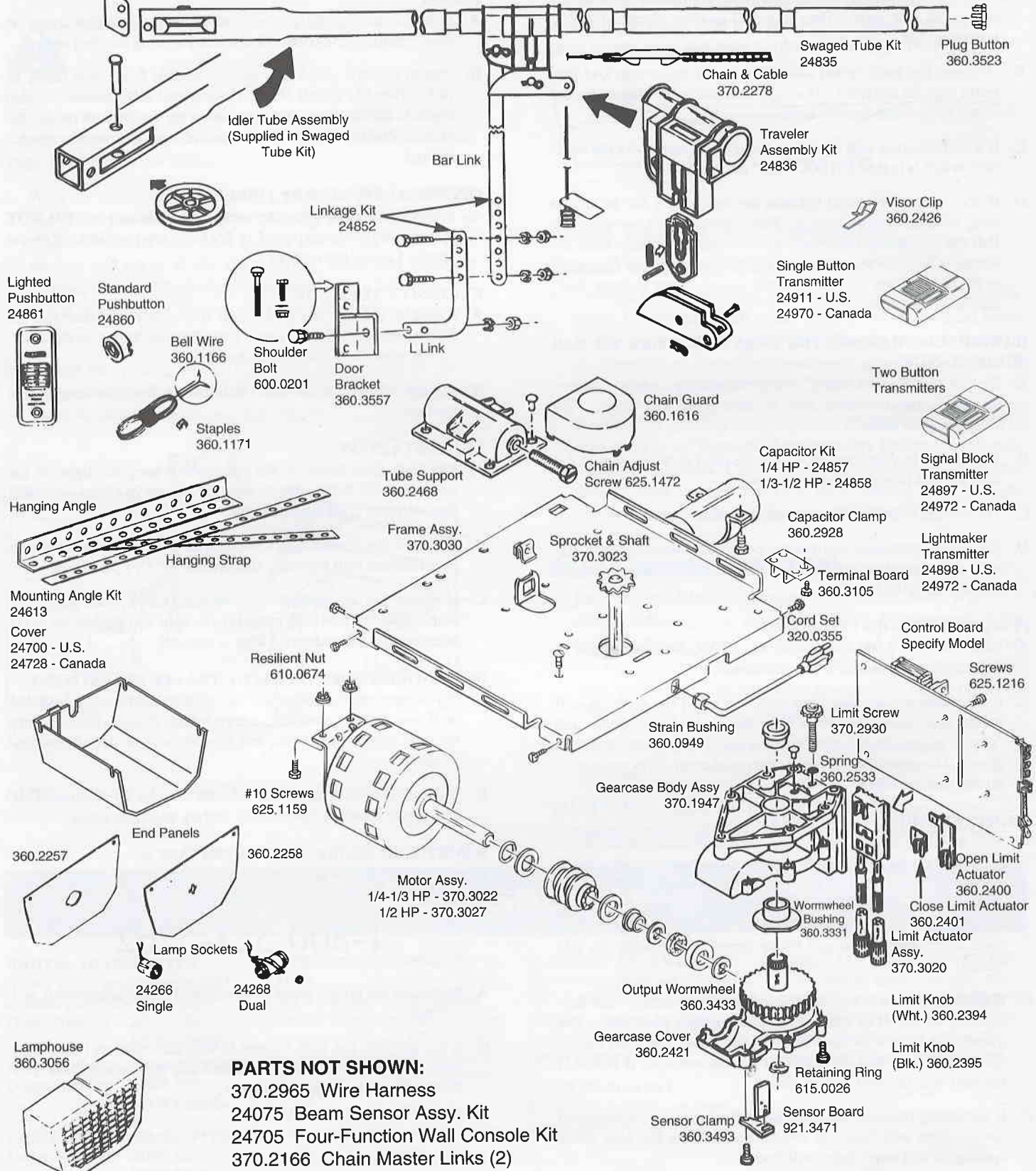

PARTS NOT SHOWN:
 370.2965 Wire Harness
 24075 Beam Sensor Assy. Kit
 24705 Four-Function Wall Console Kit
 370.2166 Chain Master Links (2)

Periodic Inspections (Check these items monthly)

LUBRICATION: For easy operation and long life, lubricate all moving parts of your door with light oil several times yearly, including roller shafts. Do not lubricate tracks or surfaces of nylon rollers.

DOOR BALANCE TEST: Check door balance at 3/4 open, mid-point and 3/4 closed positions. Refer to "Door Balance Test" in this manual.

OPEN AND CLOSED SETTINGS: Make sure the open and closed limits are properly adjusted. Refer to manual.

EMERGENCY RELEASE: Close garage door and pull the red emergency release knob to ensure the door can be released from the opener.

HARDWARE: Inspect the chain/cable tension and retighten all nuts and bolts.

SAFETY: The **ENTRAPMENT TEST** is the single most important step in the installation of your garage door opener. The door must reverse when it comes in contact with a 1-1/2" high solid object placed on the garage floor. If door does not reverse refer to the **Closed Position and Entrapment Test Instructions** in this manual or contact a door system professional.

Failure to comply with this requirement may result in serious or fatal injury to anyone trapped by a closing garage door.



CAUTION: DISCONTINUE USAGE AND CONTACT AN AUTHORIZED STANLEY DEALER OR THE STANLEY CUSTOMER SERVICE DEPARTMENT ANY TIME A MALFUNCTION IS OBSERVED.

Toll Free Help Line

Before using this phone number, please review the "Troubleshooting" information on page 21 and the "Parts List" guide on page 22.

Should you still have any questions about installation or operation, a qualified Stanley Technician will diagnose your problem and provide you with the assistance necessary for your DO-IT-YOURSELF installation or service.

**CALL TOLL FREE
1-800-521-5262**

**Please have the
MODEL NUMBER and
DATE CODE when calling.**

In-Warranty Service

During the warranty period, if the product appears as though it may be defective, call our Toll Free service before removal of the unit. A Stanley Technician will diagnose the problem and promptly supply you with the parts for DO-IT-YOURSELF repairs, or provide you with shipping instructions for factory repair or replacement.

After Warranty

Need help after the warranty period?

Need help obtaining parts, service, and accessories?

Refer to the Stanley Professional Dealer List provided with the unit or see your yellow pages listing for STANLEY under the following headings:

- Door Operating Devices
- Garage Doors and/or Garages
- Garage Door Openers
- Or your Local Stanley Dealer

Your local Stanley Dealer stocks parts and accessories and can insure that you are ordering the correct item.

If you are unable to locate a local source for service or parts, please call us at 1-800-521-5262, and ask for the Consumer Order Desk.

STANLEY[®]

HOME AUTOMATION

FOR YOUR RECORDS

Date Purchased _____

Where Purchased _____

Model Number _____

Date Code _____

Date Installed _____

DO NOT THROW THIS MANUAL AWAY!

Keep in a Safe Place for Future Reference



NOTICE

CHAIN & CABLE ASSEMBLY:

The chain and cable assembly may be pre-assembled and supplied on a roll as shown in Figure 1, or it may not be assembled and supplied in a plastic bag and coil as shown in Figure 2 with an extra master link to connect them as shown in Figure 3.

FIGURE 1



Chain/Cable

FIGURE 2



Cable

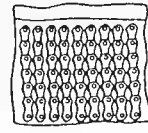

Chain



Master Link

FIGURE 3

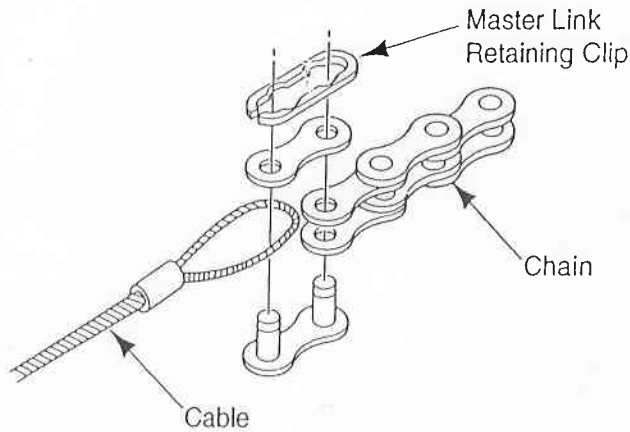

IDLER TUBE ASSEMBLY:

If the pulley was not pre-assembled to the idler tube, use the 1-1/2" clevis pin and lock clip to assemble them as shown in Figure 4.

FIGURE 4

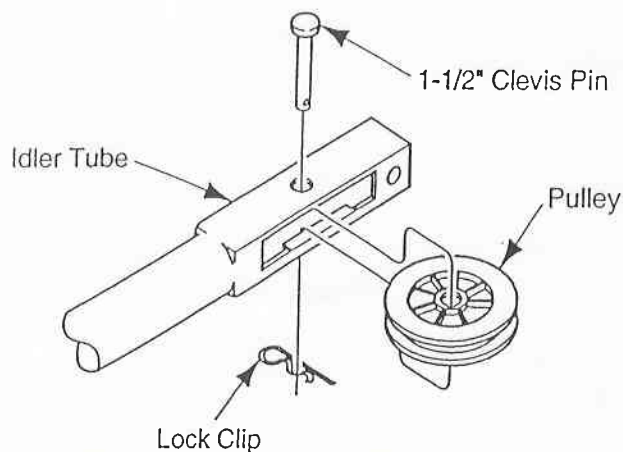

STANLEY DOOR OPENER LIMITED WARRANTY

Your Stanley garage door opener and remote radio controls are warranted against deficiencies in material and workmanship for a specific period of time based on which model number you have, providing recommended installation and maintenance procedures are followed. This warranty is in lieu of all other warranties, expressed or implied (some States do not allow limitations on how long an implied warranty lasts, so this limitation may not apply to you) and shall be considered void if damage was due to improper installation or use, connection of improper power source, or if damage was caused by fire or lightning. The Manufacturer will not be responsible for any labor charges incurred in the removal or replacement of deficient parts. In case of failure due to deficient material or workmanship during the warranty period, the electronic components (control board and transmitters) or the complete garage door opener will be repaired or replaced at the Manufacturer's option at no charge. For information on this warranty, you may call, toll-free 800-521-5262. New or factory rebuilt replacements will be used. Replacement parts are warranted for the remaining portion of the original warranty period. In the event the warranty registration is not returned, the warranty period above dates from date of shipment from Manufacturer rather than date of purchase. This warranty gives you specific legal rights, and you may also have other rights which vary from State to State. For use with 120 volt, 60 hz. current only.

STANLEY DOOR OPENER MODELS AND WARRANTY PERIODS

MODELS - ST100, ST101: Garage Door Opener and remote radio controls are warranted for a period of one (1) year from date of purchase. The motor is warranted for one (1) year.
 MODELS - ST200, ST201, ST300: Garage Door Opener and remote radio controls are warranted for a period of one (1) year from date of purchase. The motor is warranted for five (5) years.
 MODEL - D1000: Garage Door Opener and remote radio controls are warranted for a period of one (1) year from date of purchase. The motor is warranted for seven (7) years.
 MODELS - ST301, SD350: Garage Door Opener and remote radio controls are warranted for a period of one (1) year from date of purchase. The motor is warranted for eight (8) years.
 MODEL - SD351: Garage Door Opener and remote radio controls are warranted for a period of one (1) year from date of purchase. The motor is warranted for twelve (12) years.
 MODEL - ST400: Garage Door Opener and remote radio controls are warranted for a period of two (2) years from date of purchase. The motor is warranted for eight (8) years.
 MODEL - ST401: Garage Door Opener and remote radio controls are warranted for a period of two (2) years from date of purchase. The motor is warranted for ten (10) years.
 MODEL - ST500: Garage Door Opener and remote radio controls are warranted for a period of two (2) years from date of purchase. The motor is warranted for twelve (12) years.
 MODELS - SD450, SD451, SD550, SD551: Garage Door Opener and remote controls are warranted for a period of three (3) years from date of purchase. The motor is warranted for the LIFETIME of the opener for the original purchaser in the original installation.
 MODELS - SB600, ST501, ST502: Garage Door Opener and remote radio controls are warranted for a period of two (2) years from date of purchase. The motor is warranted for the LIFETIME of the opener for the original purchaser in the original installation.
 MODELS - SL700, D2000: Garage Door Opener and remote radio controls are warranted for a period of one (1) year from date of purchase. The motor is warranted for the LIFETIME of the opener for the original purchaser in the original installation.

SHOULD YOU HAVE ANY QUESTIONS CONCERNING:

- IN WARRANTY SERVICE
- INSTALLATION

CALL TOLL-FREE

1-800-521-5262

AND ASK FOR

SERVICE DEPARTMENT

A TRAINED SERVICE TECHNICIAN WILL BE PLEASED TO HELP YOU. Please have the MODEL NUMBER and DATE CODE when calling.

For After Warranty Service, Consult Your Local Yellow Pages for Your Nearest Stanley Dealer.



WHEN ORDERING REPLACEMENT PARTS, PLEASE SUPPLY THE FOLLOWING INFORMATION:

1. Type of problem: _____
2. Part number & description from homeowner's manual. _____
3. Model number and date code of door opener, _____

ST400 A05
97382

* Model number is designated on data plate located on end panel at back of power unit. See illustration below.

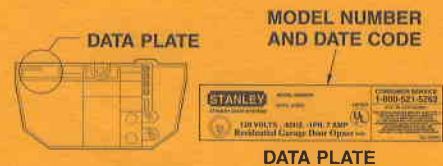

WARRANTY REGISTRATION

NAME _____ MODEL NO. _____ DATE CODE _____
 ADDRESS _____ DATE PURCHASED _____ PRICE PAID _____
 CITY _____ STATE _____ ZIP _____ PHONE _____
 DEALER NAME _____ CITY _____ STATE _____

MARKETING QUESTIONNAIRE

Please circle your answer to the following questions. Thank you.

- | | | |
|--|---|--|
| 1. Is this opener a gift item?
Yes No | 5. Have you ever seen a T.V. ad for Stanley Openers?
Yes No | 10. Length of time to install?
1 to 2 hrs. 3 to 4 hrs.
5 to 6 hrs. Over 6 hrs. |
| 2. Did you previously own an opener?
Yes No | 6. Have you ever heard a radio ad for Stanley Openers?
Yes No | 11. On what type of door was opener installed?
Sectional track door Trackless door
One-piece track door Pivot door |
| 3. What influenced you the most to buy this opener?
• Friend has opener • Newspaper Ad
• In-store display • Literature
• T.V. ad • Stanley reputation
• Friend has other Stanley opener model • Price
• Light Control | 7. Your age?
Under 25 25 to 40
41 to 54 55 or over | Why did you purchase this opener versus another model? _____ |
| 4. Who actually decided to buy a Stanley opener?
Self Spouse Other | 8. Who installed your opener?
Yourself Paid Pro Friend | Which add accessories did you purchase with your opener? (i.e., hand transmitter) _____ |
| | 9. Did you move into your home within last 6 months?
Yes No | Your Comments _____ |

IT'S THE LAW

GARAGE DOOR OPENERS MUST BE PROVIDED WITH AN EXTERNAL ENTRAPMENT PROTECTION SYSTEM SUCH AS A "BEAM SENSOR" TO HELP PROTECT AGAINST ENTRAPMENT BETWEEN THE BOTTOM OF THE GARAGE DOOR AND THE FLOOR.

THIS SYSTEM CAN NOT BE DEFEATED OR "BY-PASSED".

THE DOOR CAN NOT BE CLOSED USING THE HAND HELD TRANSMITTER IF THE BEAM SENSOR SYSTEM IS NOT CONNECTED AND PROPERLY ALIGNED. IT CAN, HOWEVER, BE OPENED.

IF THIS SAFETY SYSTEM IS NOT PROPERLY CONNECTED, THE DOOR CAN ONLY BE CLOSED BY HOLDING THE WALL-MOUNTED PUSHBUTTON.

EFFECTIVE FOR OPENERS MANUFACTURED:

AFTER JANUARY 1, 1993 - UNITED STATES

AFTER JANUARY 1, 1994 - CANADA

WARRANTY & ACCESSORY INFORMATION INSIDE

023.0266E



Door Sales Company, Inc.

43678 Gratiot • Clinton Township, Michigan 48036
(586) 468-9787 • FAX (586) 463-3299 • 800-462-2593
www.fjfdoor.com

PROMPT EMERGENCY SERVICE CALL ANYTIME

Sales Receipt

Date	Sale No.
4/17/2012	8794

Sold To
CASH SALE

Check No.	Payment Method	Rep
	Cash	KL

Item	Description	Qty	U/M	Rate	Amount
1/8"	1/8" raw cable	10		1.40	14.00T
Multi-Purpose L...	Multi-Purpose Spray Lube 6oz	1		5.95	5.95T

Subtotal				\$19.95
Sales Tax (6.0%)				\$1.20
Total				\$21.15

Automatic Garage Door Opener Safety & Maintenance Guide

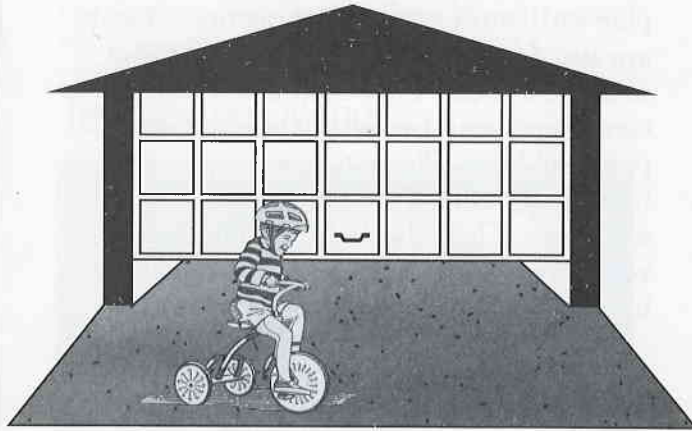

Garage door opener safety – An automatic decision

A garage door is the largest moving object in the home. An improperly adjusted garage door opener can exert deadly force when the door closes – which could lead to entrapment of children or adults and subsequent injury or death from asphyxiation.

Safety Is Everyone's Business

Automatic garage door openers are installed in millions of households. Proper installation, operation, maintenance and testing of the garage door and automatic opener are necessary to provide a safe, trouble-free product. An improperly adjusted garage door opener can exert deadly force when the door closes. This could lead to serious injury or death from being hit by a closing garage door or from becoming trapped under the door.

Careless operation and allowing children to play with or use garage door opener controls are also dangerous situations that can lead to tragic results. A few simple precautions can protect your family and friends from potential harm. Please take a few minutes to read the following maintenance and safety tips. Then check the operation of your garage door and opener to ensure they function in a safe and trouble-free manner.



Some of the following precautions and warnings are identified with this warning symbol. This symbol indicates some of the conditions that can result in serious injury or death.

Garage Door Openers Are Not Toys

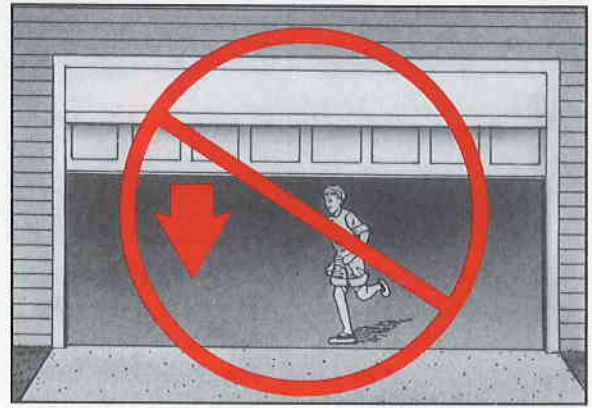

Do not stand or walk under a moving door! Do not let children play "beat the door." It is very dangerous and can result in serious injury or death. Adults should set a good example.



Keep transmitters and remote controls out of reach of children. Do not let children play with or use the transmitters or remote controls.

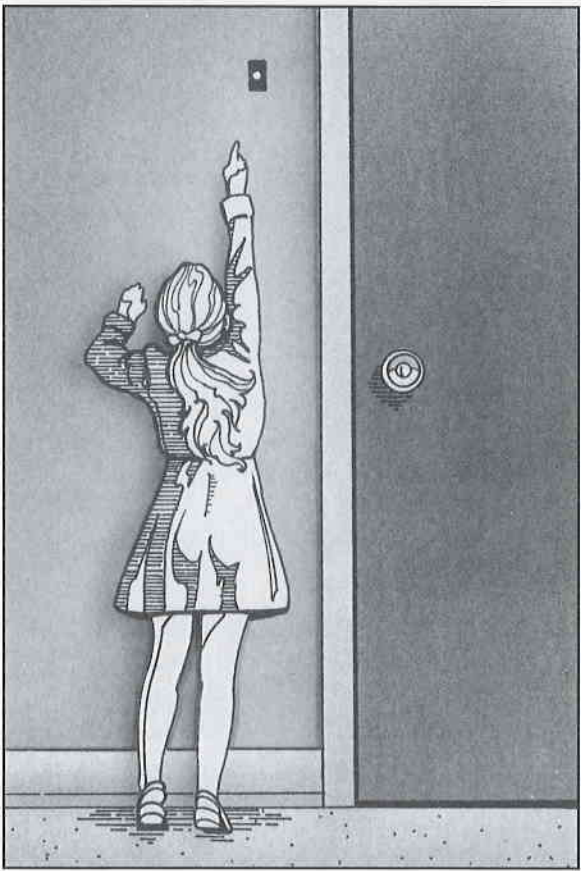

The pushbutton wall control should be out of reach of children (at least 5 feet from the floor) and away from all moving parts. Mount and use the button where you can clearly see the closing garage door.

Teach Your Children About Garage Door Safety

Discuss garage door safety with your children. Explain the danger of being trapped under the door. Do not let children play with or use the pushbutton or transmitter.

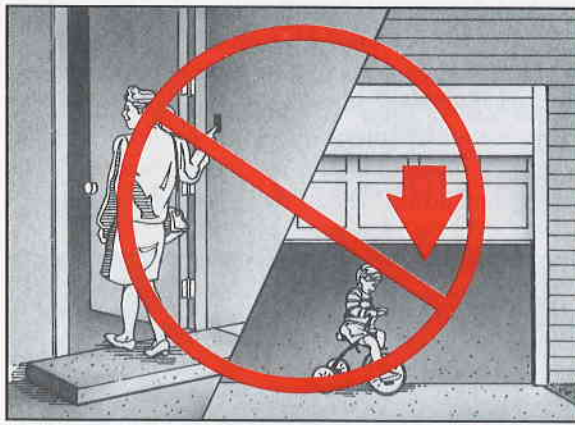

When using the pushbutton or transmitter, keep the door in sight until it completely closes. Teach children to never play under or near an open garage door. Do not allow children to run under a closing door.

Testing The Opener

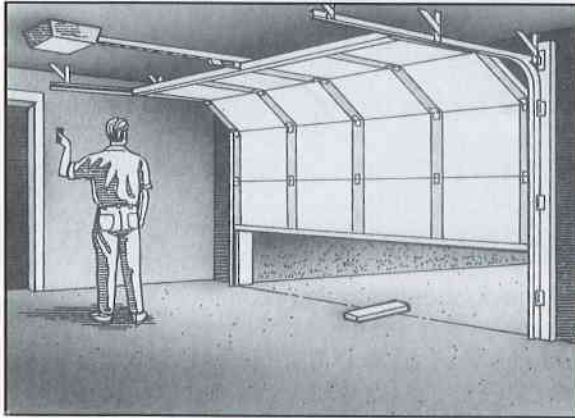

Make sure your opener has a reversing feature and test the reversing feature every month. With the door open, place a 1 inch thick piece of wood, laid flat, on the floor in the door's path at approximately the center of the door. While a 1 inch piece of wood is best, if you don't have one, use a 2 x 4 laid flat. Test the balance of the door, as discussed on the back page, before performing the reversal test.

Push the control button to close the door. The door opener must reverse and open the door when it strikes the wood. If the opener does not reverse, have it repaired or replaced. Also consider replacement of the garage door opener if it is an older model. Have a qualified individual adjust, repair or replace the parts.

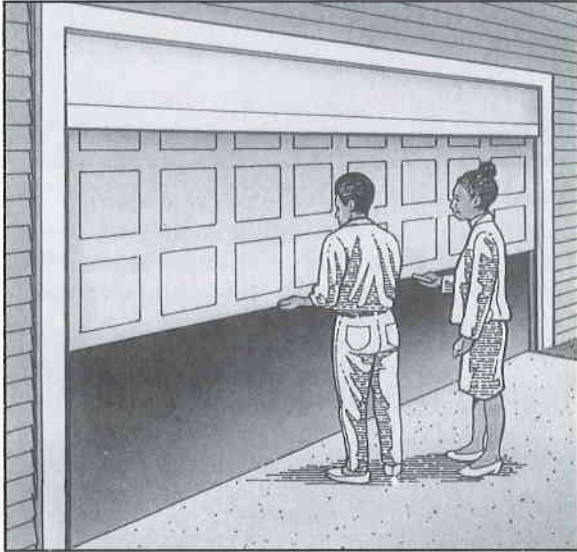

Test the force setting of your garage door opener by holding up the bottom of the door as it closes. If the door does not reverse **readily**, the force is excessive and needs adjusting. Your garage door opener owner's manual will explain how to adjust the force sensitivity. A qualified individual should adjust it. To avoid entrapment, be sure to perform the 1 inch reversing test after any repairs or adjustments are made to the garage door or opener.

Many garage door openers can be equipped with accessory safety devices. Consider adding an electric eye or edge sensor as an extra measure of safety to protect against entrapment.

Routine Maintenance Can Prevent Tragedies

There are routine maintenance steps that you should follow once a month. Review your owner's manual for both the door and door opener. If you don't have the owner's manuals, contact the manufacturer(s) and request a copy for your specific model(s). Look for the opener model number on the back of the power unit.

Look at the garage door springs, cables, rollers, pulleys and other door hardware for signs of wear. If you suspect any problems, have a qualified person make repairs. The springs and related hardware are under high tension and can cause severe injury when handled improperly.



WARNING – Springs are under high tension. Only qualified individuals should adjust them.

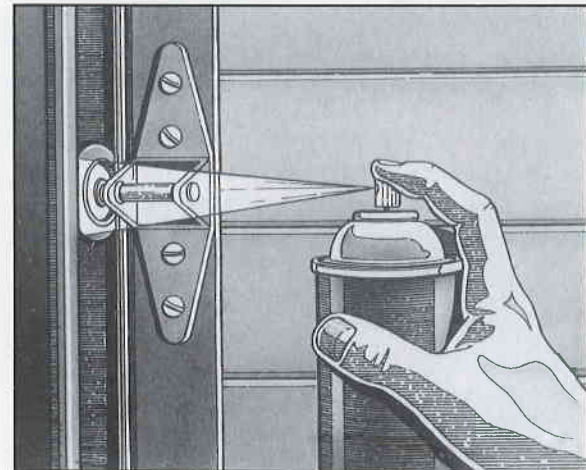

Rollers and hinges of a garage door require periodic lubrication. Use a spray silicone or lightweight household oil according to the instructions in your owners manual.



Periodically test the balance of your door. **Start with your door closed.** Disconnect the garage door opener release mechanism so you can operate the door by hand. You should be able to lift the door smoothly and with little resistance. It should stay open around three to four feet above the floor. If it does not, it is out of balance. Have it adjusted by a professional.

Garage Door Opener Safety An Automatic Decision

Take a few minutes to inspect and test your garage door system. Make monthly inspection and testing a part of your regular routine. Safety is everyone's business. Make garage door opener safety automatic in your home.

This important information is provided by the U.S. Consumer Product Safety Commission, the National Safety Council and the Industry Coalition for Automatic Garage Door Opener Safety.



National Safety Council

© 1991 The Industry Coalition For Automatic Garage Door Opener Safety Printed in U.S.A.

Automatic Garage Door Opener Safety & Maintenance Guide

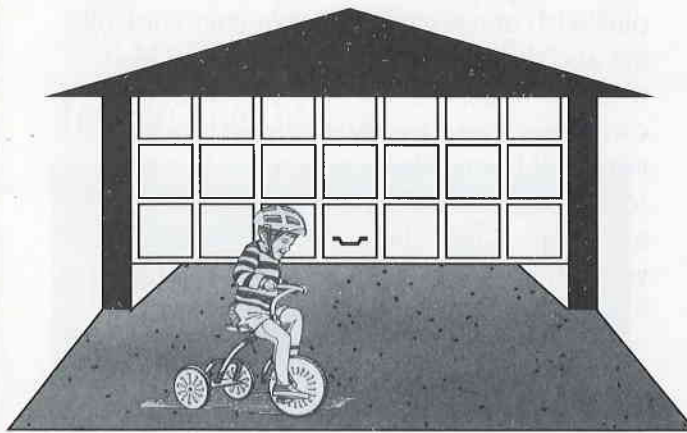

Garage door opener safety – An automatic decision

A garage door is the largest moving object in the home. An improperly adjusted garage door opener can exert deadly force when the door closes – which could lead to entrapment of children or adults and subsequent injury or death from asphyxiation.