

starglider 300 E

GB Installation and Operating Instructions

1 - 28



Contents

| | | | |
|---|-----------|---|-----------|
| General Tips | 2 | Functions and Connections | 13 |
| Symbols | 2 | General Tips | 13 |
| Safety Instructions | 2 | Overview of Control System | 13 |
| Operation | 2 | DIP Switches 1 - 8 | 13 |
| Permitted Gate Dimensions | 3 | Radio Receiver | 14 |
| Technical Data | 3 | Obstacle Detection (DIP 1, 2 + 3) | 15 |
| Dimensions | 3 | Automatic Close Mode | 15 |
| Components of Drive System | 3 | Warning Time (DIP 5) | 16 |
| EU Manufacturer's Declaration | 3 | Fraba System (DIP 6) | 16 |
| Preparations of Installation | 4 | Separate Signals for Closing and Opening (DIP Switch 7) | 16 |
| Safety Instructions | 4 | Partial Opening (DIP 8) | 16 |
| Personal protective equipment | 4 | Terminal bar with 24 slots | 17 |
| Scope of Delivery | 4 | Connection to Power Supply | 17 |
| Installation Tips | 5 | Connection of Push-Buttons | 17 |
| General Preparation | 5 | Connection of Fraba System | 17 |
| Installation | 6 | Connection of Light Barrier | 18 |
| Safety Instructions | 6 | Connection of Safety contact strip | 18 |
| Location of Installation | 6 | 24 V Connection | 18 |
| Foundation | 6 | Connection of Warning Lamps | 18 |
| Installation to Ground | 6 | 12 V Connection | 18 |
| Mounting of rack | 7 | Floating relay output | 19 |
| Positioning of Stops | 7 | Connection of External Antenna | 19 |
| Connection to power supply | 8 | Accessories | 20 |
| Commissioning | 10 | Maintenance and Servicing | 22 |
| Safety Instructions | 10 | Important Information | 22 |
| Teaching in of Drive | 10 | Regular Inspection | 22 |
| Teaching in of Hand-Held Transmitter | 10 | Replacement of Fuses | 23 |
| Operation | 11 | Additional Information | 23 |
| Safety Instructions | 11 | Disassembly | 23 |
| Opening the Gate | 11 | Disposal | 23 |
| Closing of Gate | 11 | Warranty and After-Sales Service | 23 |
| Pulse Sequence of Door Movement | 11 | Troubleshooting | 24 |
| Reset of Control System | 11 | Spare Parts List | 26 |
| Emergency Release | 12 | Glossary | 26 |
| Function of Button 2 | 12 | | |
| Intermediate Stop | 12 | | |
| Stop forced by Obstacle | 12 | | |

General Tips

Symbols



Warning symbol:
Indicates a potential risk. Failure to follow instructions may result in serious injury!



Note symbol:
Information, useful advice.

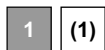

Refers to the relevant illustration in the document.

Safety Instructions

General

- These Installation and Operating Instructions must be read, understood and observed by all persons installing, operating or maintaining the drive mechanism.
- Installation, connection and commissioning of the drive mechanism may only be carried out by qualified specialists.
- The drive system may only be mounted onto properly aligned gates. If installed in incorrectly aligned gates, there is a risk of serious injury or damage to the drive system.
- The manufacturer shall not be liable for damages or disruptions due to non-compliance with the Installation and Operating Instructions.
- Please ensure that the Installation and Operating Instructions are at all times accessible to all persons operating the gate.
- Observe and comply with the locally applicable accident prevention regulations and EU standards.
- Observe and comply with the directive on "Power-driven Windows, Doors and Gates - BGR 232" issued by the Employers' Liability Insurance Association (mandatory for operator in Germany).
- Prior to carrying out any work on the drive system, disconnect it from the power supply and secure it against inadvertent switching on.
- Only use the manufacturer's original spare parts, accessories and fixing material.

Storage

- The drive mechanism may only be stored indoors, in a dry environment at an ambient temperature of between -20°C and +50°C.
- Store drive system as shown below.

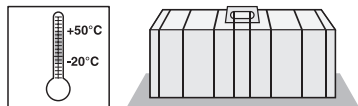

Operation

- The drive mechanism may only be operated if a risk-free force tolerance has been set. The force tolerance must be set as low as is required to ensure that the gate's closing force does not constitute a risk (see section "Force settings").
- Keep your hands clear of the moving gate or any other moving parts.
- Keep children, disabled persons and animals away from the gate.
- Only drive through the gate when it is fully opened.
- There is a risk of injury from being trapped or cut on the gate system's moving parts or edges.

for Radio Remote Control

- The radio remote control may only be used for equipment and systems in which defective remote operation of the transmitter or receiver does not constitute a risk to people, animals or property, or in cases where this risk is eliminated by means of additional safety facilities.
- The user must be made aware of the fact that the remote control of equipment with accident risk potential may only occur, if at all, when the equipment concerned is clearly visible.
- Radio remote control may only be used if movement of the gate can be supervised and there are no persons or objects in the area of movement.
- Store the hand-held transmitter in such a way that there is no risk of it being accidentally operated by, for instance, children or animals.
- The operator of this radio-controlled equipment is not in any way protected against interference from other telecommunication systems and facilities (e.g. other radio-controlled equipment that is licensed to operate at the same frequency range). Should serious interference be encountered, please contact your nearest telecommunications office with interference measuring facilities (radio signal localisation)!
- Do not use hand-held transmitters near locations or installations that are susceptible to radio interference (e.g. airports, hospitals).

Rating Plate

The rating plate is located on the cover of the control unit housing.

Exact type designation and date of manufacture (month/year) of the drive are to be found on the rating plate.

Normal Use

- The drive is designed for the exclusive purpose of opening and closing sliding gates (according to EN 12433-1), hereafter referred to as gates. Any other use does not constitute normal use. The manufacturer accepts no liability for damage resulting from use other than normal use. The user accepts sole responsibility for any risks thereby incurred. Improper use shall void all warranty.
- Gates operated automatically with a drive must comply with the applicable standards and directives as amended: e.g. EN 12604, EN 12605. The drive mechanism may only be used, if in a technically perfect condition, and in compliance with these Installation and Operating Instructions, particularly regarding correct and responsible use.
- The gate may not be installed at a slope.
- The runner rail must be installed in such a way that water can drain off in order to prevent the formation of ice in winter.
- Ensure that the gate is sliding smoothly on the rail. Otherwise, the sensors of the drive system may not detect obstacles and might fail to halt the gate.
- The gate must be equipped with stops at both the open and closed position, as it might otherwise be dislocated from the rail in the event of an emergency release.
- Any defects that may impair the safe operation of the equipment should be eliminated without delay.
- The gate wings must be stable and warp-proof, i.e. they should not bend or warp during opening or closing operations.
- The drive mechanism is unable to compensate for any defects in the gate or incorrect installation.
- Do not operate the drive in areas where there is a risk of explosion.
- Do not operate the drive in rooms where the air contains aggressive gases.

General Tips

Permitted Gate Dimensions

| | |
|----------------|--------------|
| - Max. travel: | max. 6000 mm |
| - Weight: | max. 300 kg |
| - Slope: | 0 % |

Technical Data

| | | |
|--|-----------|------|
| Rated voltage: | 220 - 240 | AC/V |
| Rated frequency: | 50/60 | Hz |
| Operating temp. range: | -20 - +50 | °C |
| Protection class: | IP 44 | |
| Max. traction force and pressure: | 480 | N |
| Rated traction: | 145 | N |
| Rated current consumption: | 0,65 | A |
| Rated power consumption: | 120 | W |
| Max. speed: | 200 | mm/s |
| Rated consumption in standby: | ~ 2 | W |
| Weight: | 12,5 | kg |
| Operating factor: | 40 | % |
| Workplace noise emission < 75 dBA - drive only | | |

Dimensions

All dimensions in mm.

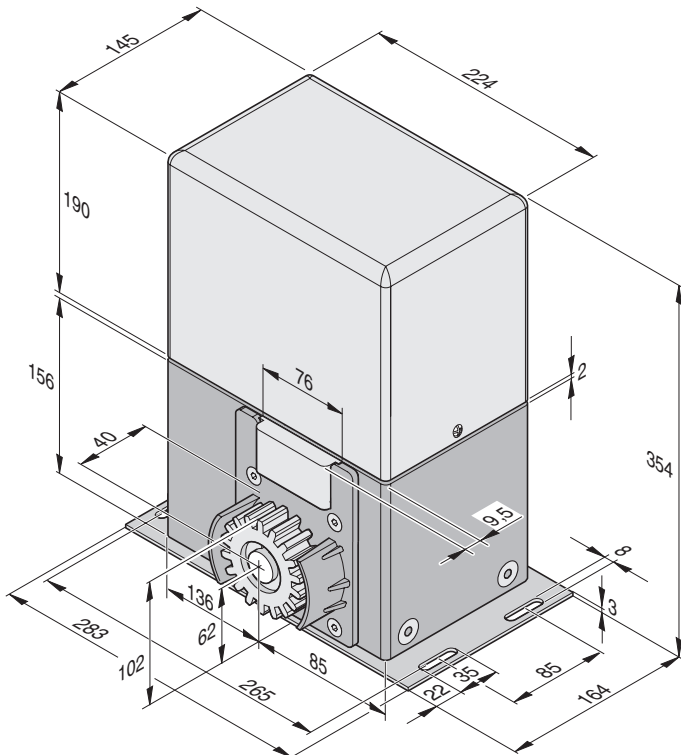

Components of Drive System

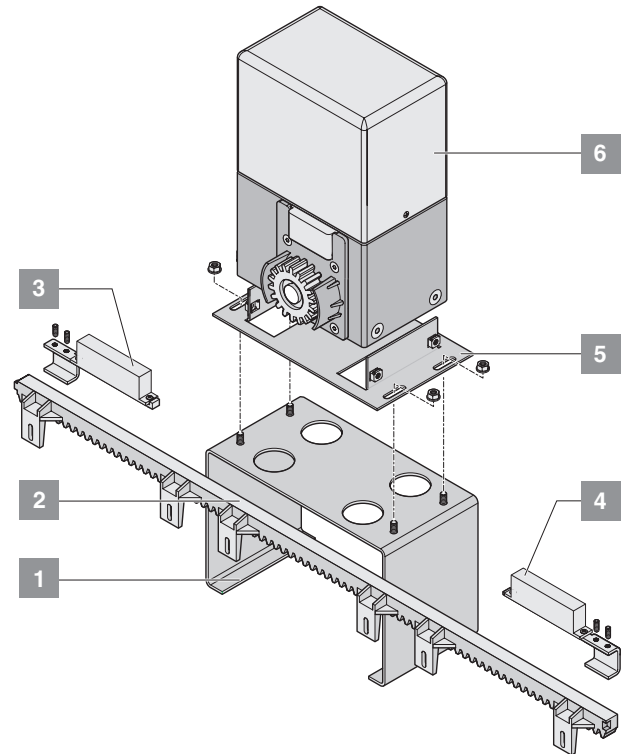

- 1 Base frame (optional), see chapter "Accessories"
- 2 Rack
- 3 End switch magnet right
- 4 End switch magnet left
- 5 Anchor plate
- 6 Drive system including control system and radio receiver

EU Manufacturer's Declaration

The company

SOMMER Antriebs- und Funktechnik GmbH
Hans-Böckler-Straße 21-27
D-73230 Kirchheim/Teck

herewith declares that its drive system:

- starglider 300 E

complies with the following Directives:

- Machine Directive 98/37/EU
- Low Voltage Directive 73/23/EEC
- European Directive on Electromagnetic Compatibility 89/336/EEC

The following standards/draft standards were applied:

- EN 60335-1, EN 60335-2-95, DIN VDE 0801, EN 12453, EN 12445
- EN 55014-1, EN 55011, EN 61000-3-2, EN 61000-3-3

Note:

the gate system may not be commissioned until it has been established that the system in which the above drive is to be installed fulfils all specifications of the relevant EU Directives.

Kirchheim, 03.05.2005

Frank Sommer
Managing Director

Preparations of Installation

Safety Instructions

- The rated voltage of the power supply must correspond to that indicated on the type plate of the drive.
- All peripheral devices must be equipped with circuit breakers for supply current according to IEC 364-4-41.
- The cabling of peripheral devices must comply with IEC 364-4-41.
- Installation, connection and commissioning of the drive mechanism must be carried out by qualified specialists.
- The gate may only be operated if there are no persons, animals or objects in the area of movement.
- Keep children, disabled persons and animals away from the gate.
- When drilling fixing holes, always wear protective goggles.
- Cover the drive during drilling to ensure that no particles can penetrate the mechanism.

⚠ The drive system must be installed on level and firm ground. The drive system may only be mounted onto properly aligned gates. Incorrect alignment of gates may lead to serious injury.

- Gates must be of a robust design as they are exposed to high traction and pressure forces. Lightweight gates in plastic or aluminium might have to be reinforced before the drive is mounted. If in doubt, contact the gate supplier.
- Remove or disable all gate locking devices.
- Use only approved fixtures (e.g. plugs, screws). The fixtures must be suitable for the ground onto which the drive is to be mounted.
- Ensure that the gate can be moved with ease.

Tools

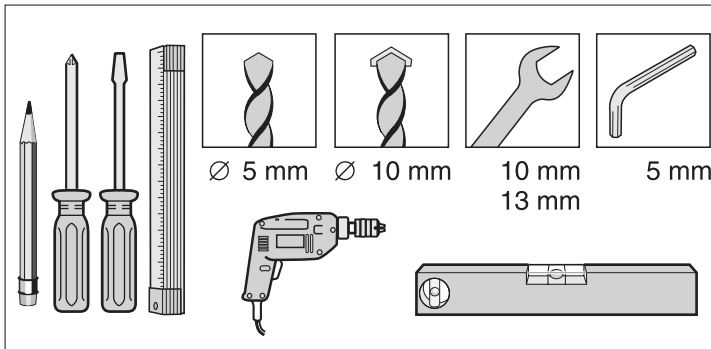

Personal protective equipment



- Protective goggles: When drilling the anchor holes.

Scope of Delivery

- The scope of delivery might vary, depending on the design of the drive system.
- Prior to installation, inspect the supplied parts to ensure that no components are missing.

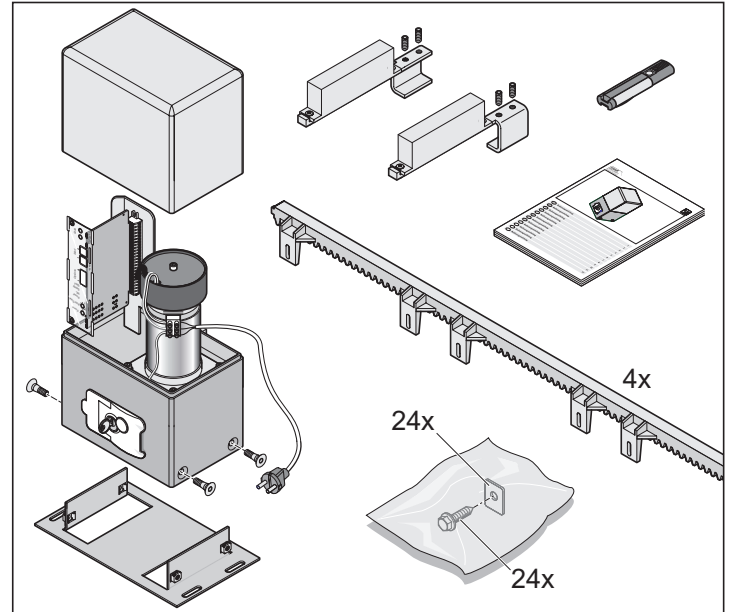

Complete drive package

Packaging (L x W x H) 1040 x 220 x 470 mm

Weight 20,5 kg

- 1 x sliding gate drive with control system and radio receiver
- 1 x anchor plate
- 1 x 4-key hand-held transmitter
- 4 x 1-m racks
- 1 x assembly pack
 - 24 screws
 - 24 washers
- 1 x end switch magnet left, including 2 screws
- 1 x end switch magnet right, including 2 screws
- 1 x installation and operating manual

Individual drive

Packaging (L x W x H) 310 x 215 x 370 mm

Weight 12,5 kg

- 1 x sliding gate drive with control system and radio receiver
- 1 x anchor plate
- 1 x end switch magnet left, including 2 screws
- 1 x end switch magnet right, including 2 screws
- 1 x installation and operating manual

Preparations of Installation

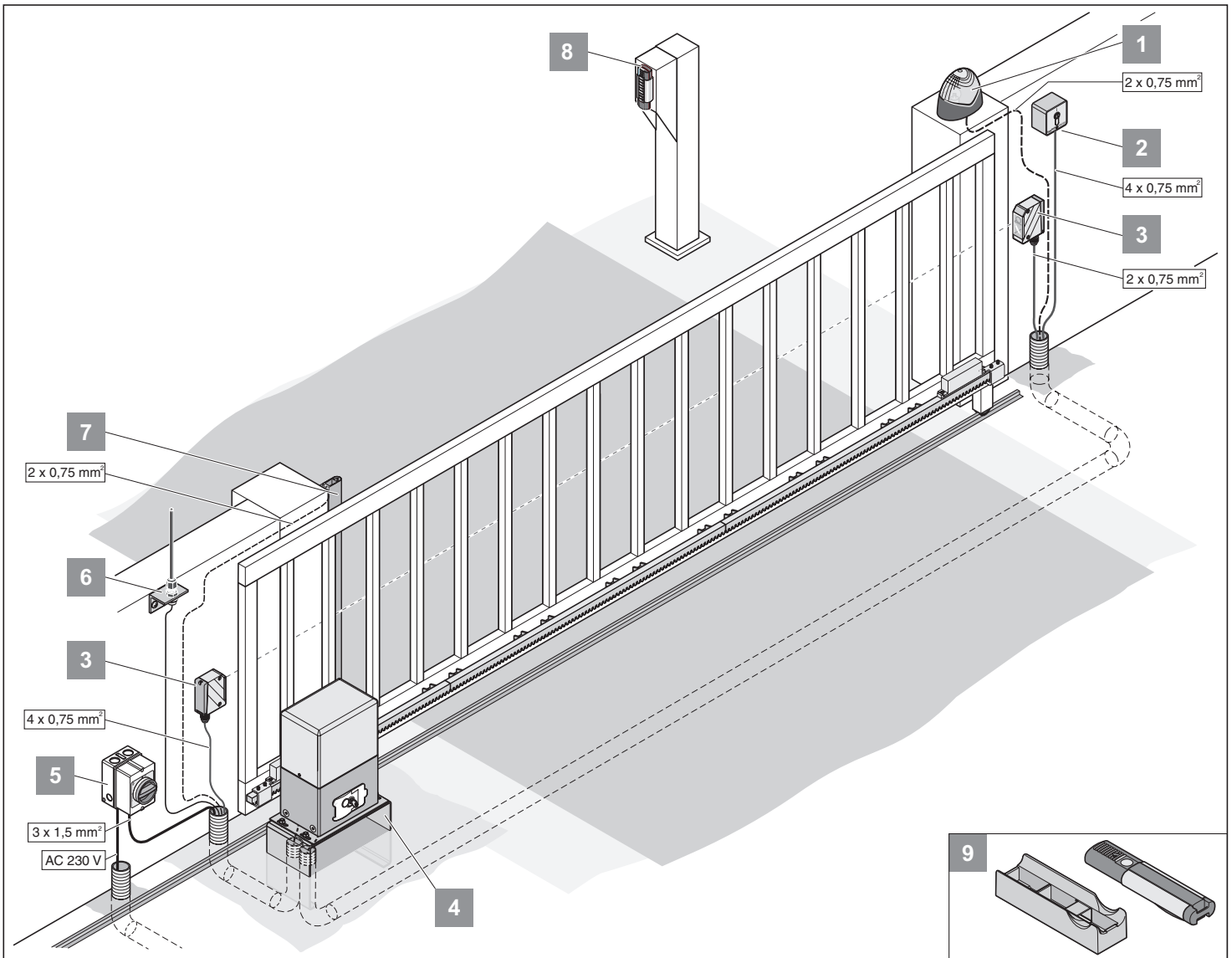

Installation Tips

- Safety devices must be installed as normally closed contacts. This ensures that safety is not compromised in the event of a defect at the drive system.
- Consult the operator on the envisaged locations for accessories.

i The gate might be operated with a number of different control devices: Hand-held transmitter, Telecody, interior push-button and key switch. For the hand-held transmitter, Telecody and interior push-button, there is no need for cables as they are radio control devices. For more information, contact the supplier.

1. Warning lamp DC 24 V
2. Key switch (with 1 or 2 contacts)
3. Light barrier (mandatory for gates with automatic closing mechanism, see EN 12543)
4. Base frame
5. Main switch (lockable)
6. Rod antenna (including 10-m cable)
7. Safety switch strip (8.2 kOhm, Fraba System)
8. Telecody
9. Holder for remote control, for installation in car or on wall

General Preparation

- Before installing the drive, remove or disable all locking devices (electrical locks, locking bolts, etc.) of the gate.
- Ensure that the design of the gate is stable and suitable to be equipped with a drive.
- When operated, the gate may not sway to the side.
- The castors on the lower rail and/or castors on the upper rail must run smoothly without excessive friction.
- To ensure that the gate cannot derail, it must be equipped with stops at positions "Gate OPEN" and "Gate CLOSED".
- Install conduits for cables (power supply, connection of accessories such as light barrier, key switch box, warning lamp, etc.) at the base of the gate.

Installation

Safety Instructions

- For the connection of the control system to the power supply, contract an electrician.
- Ensure that the drive system is firmly secured to the ground and that the racks are properly fixed to the gate, as these devices are exposed to considerable forces during the opening and closing of the gate.
- If the opening/closing of the gate is controlled by means of a push-button, the button must be mounted at a minimum height of 1.6 m above ground to prevent children from operating the gate.
- During operation of the gate, the rack may not be pressed onto the toothed wheel, as this could damage the drive mechanism.
- During installation, comply with the relevant standards such as EN 12604 and EN 12605.

Location of Installation



Condition as delivered is operator left, gate opens to the left.

Left drive

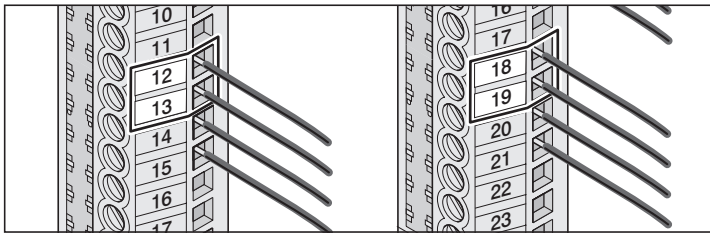
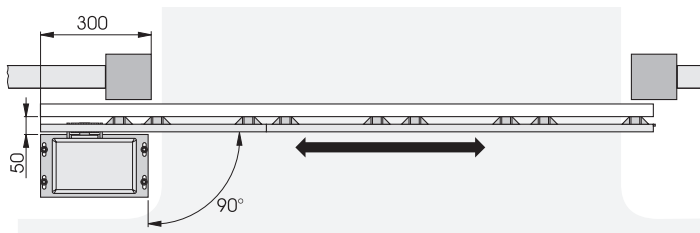

| | | |
|-------------|-------|---------------------------------|
| Terminal 12 | red | motor + |
| Terminal 13 | black | motor - |
| Terminal 18 | green | magnetic end switch gate OPEN |
| Terminal 19 | white | magnetic end switch gate CLOSED |

Right drive

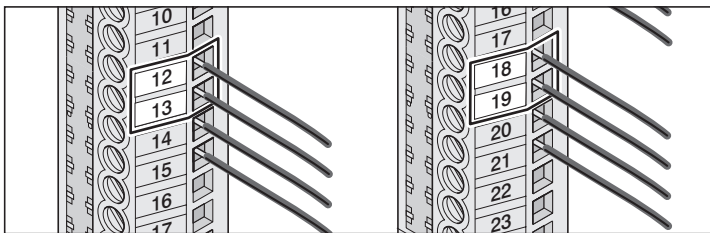
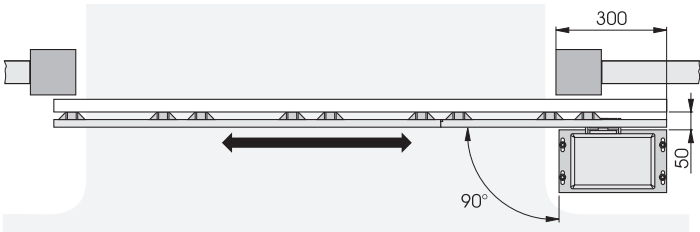

| | | |
|-------------|-------|---------------------------------|
| Terminal 12 | black | motor - |
| Terminal 13 | red | motor + |
| Terminal 18 | white | magnetic end switch gate CLOSED |
| Terminal 19 | green | magnetic end switch gate OPEN |

Foundation

- For cantilevered gates, the drive must be mounted between the castor blocks.
- Ensure that the foundation extends to a frost-free depth (for Germany approx. 800 mm).
- The foundation must be hardened and level.
- For the dimensions of the foundation, see figure below.

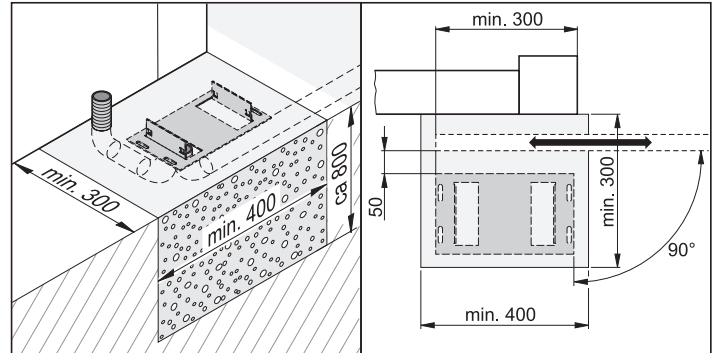

Installation to Ground

Installation to ground

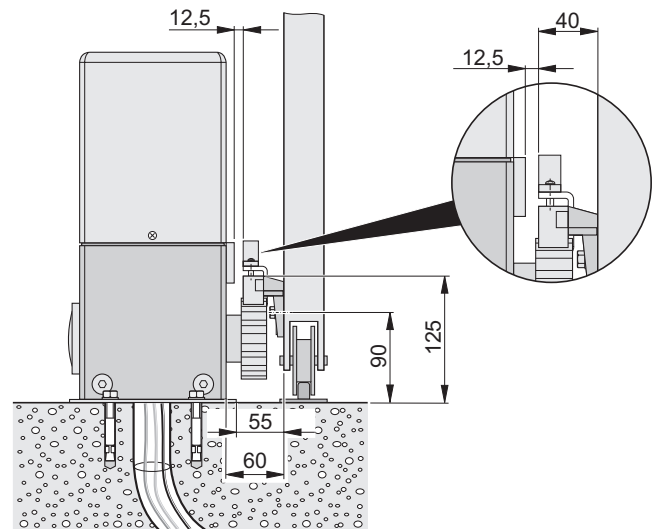

Installation with stay bolts

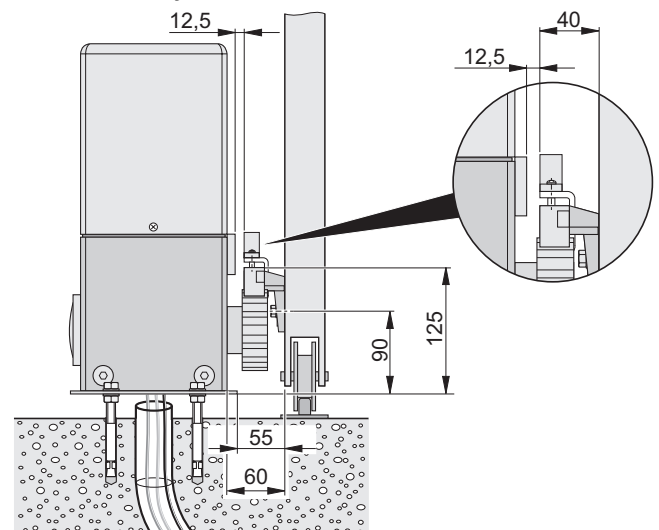

Installation

Procedure:

i Dispose of packaging material according to the applicable statutory regulations.

- Remove drive system from packaging.
- Insert cables into conduits and label for subsequent connection.

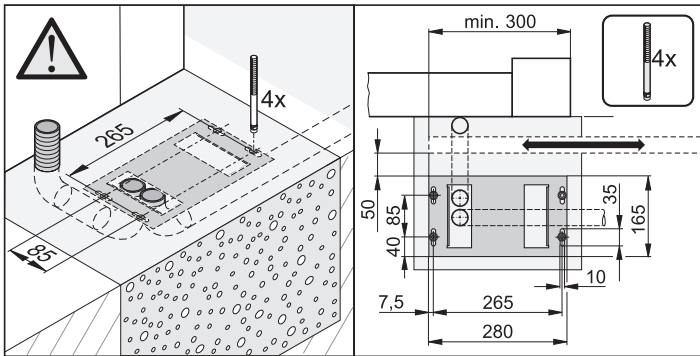
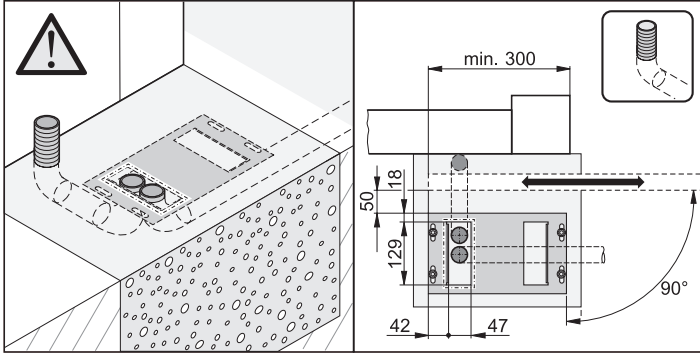

- Position anchor plate.
- Mark boreholes and drill holes.
- Insert plugs and stay bolts (if any).

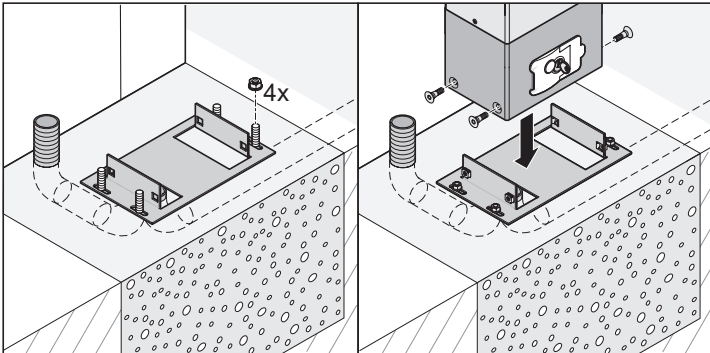

- Secure anchor plate. Check clearances.
- Position drive onto the anchor plate and secure with screws.
- Insert cables.

Mounting of rack

i The complete drive package comes with 4 racks of 1 m length. If you require additional racks, please contact your supplier.

- Mount the first rack at the opening edge of the gate. To mark the holes for the securing bolts, position the respective rack over the toothed wheel.

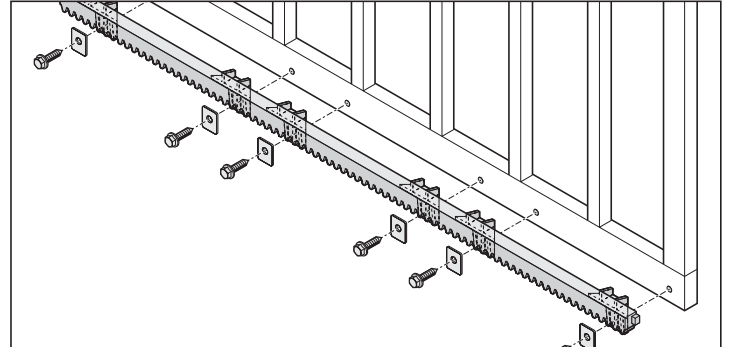

- Secure rack to the gate, using appropriate fixtures (e.g. supplied screws). Secure rack at all six fixing points to the gate.
- Unlock drive.

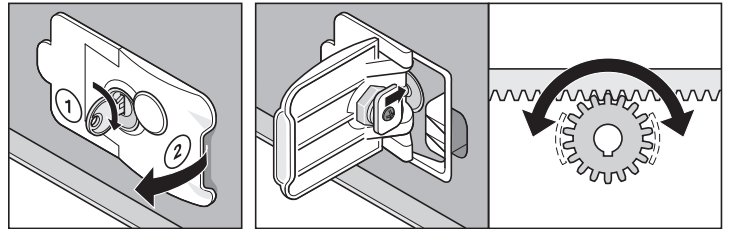

- Turn key (1) clockwise by 90° and pull lever (2) until it engages. The drive is now released and the gate can be moved by hand.

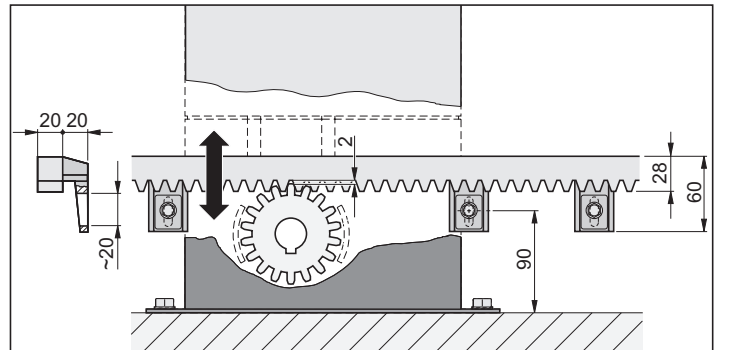

- Ensure that the rack is not pressed onto the toothed wheel in any gate position, as the gear system could otherwise be damaged.
- Alignment of rack: Move gate carefully back and forth. Adjust the rack and toothed wheel in such a way that there is a clearance of approx. 2 mm along the entire length of the gate. To adjust the distance between rack and toothed wheel, adjust the screw settings in the long slots.

Installation

Connection to power supply

⚠ The drive is supplied with a power supply cable. Do not use any other cable for connection to the mains. After completion of the installation, cut power supply cable to the required length and insert in the conduit. The power cable is not suitable for continuous operation or outdoor installation.

- For the connection of the drive system to the power supply, contract an electrician.

⚠ The connection must be established according to EN 12453 (single-pole circuit breaker). Install main switch with lock (single-pole switch-off) in order to prevent inadvertent switching on of the system during maintenance or servicing.

- Prior to carrying out any work on the drive system, disconnect it from the power supply and secure it against inadvertent switching on.
- We recommend installing a protective motor switch to protect the drive system against surges.
- During work at the control system, protect it against the elements (rain, snow, etc.).

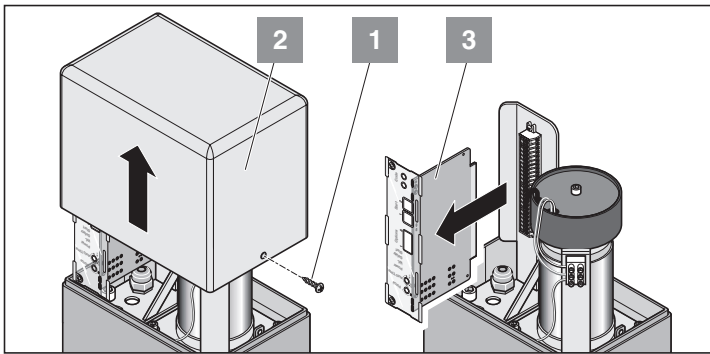

- Loosen screws (1). Remove cover (2).
- Pull out control unit (3).

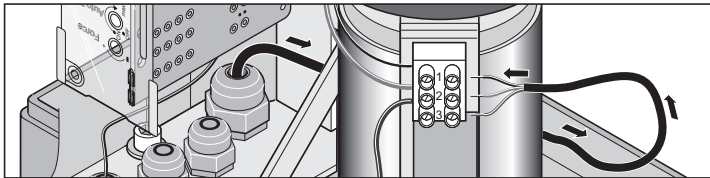

- Connect power supply cable:
 1. Live conductor (L) 230 V AC
 2. Neutral conductor (N)
 3. Earth conductor (PE)
- Tighten cable screws; block unused conduit channels using a piece of cable or similar material.
- Connect control system (3), ensure correct pole connection.

Check direction of drive

- Bring door to middle position
- Switch on the power supply.

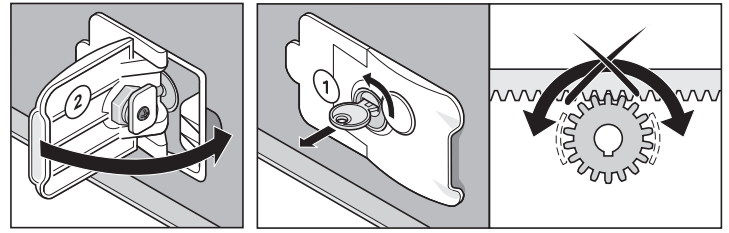

- Lock drive:
Close lever (2) - turn key (1) anticlockwise by 90° and remove it: The drive engages and the gate cannot be opened by hand.

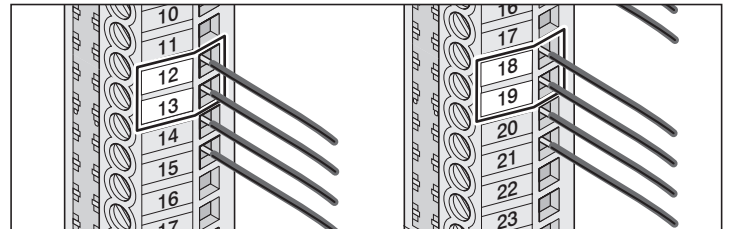
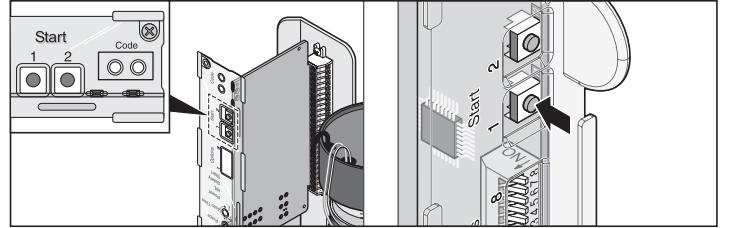

- Close gate and press button (1).
First movement direction after switching on the main switch must be in the gate OPEN direction. If the operator closes the door - then swap the cable on terminals 12 + 13 (motor) and 18 + 19 (end switches).

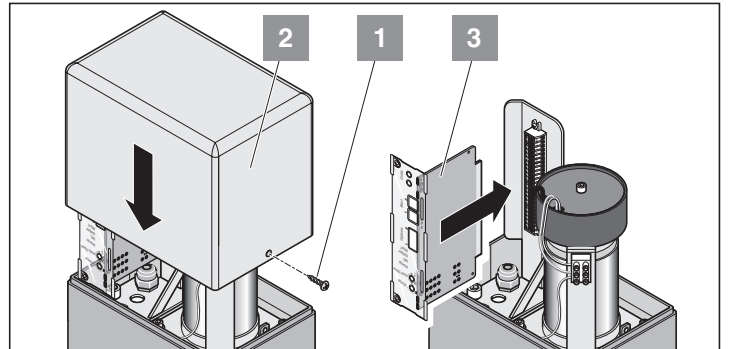

- Replace cover (2) and tighten screws (1).

Installation

Positioning of Stops

⚠ Caution!
In the event of an emergency release, the gate might open/close automatically.

- Unlock drive.

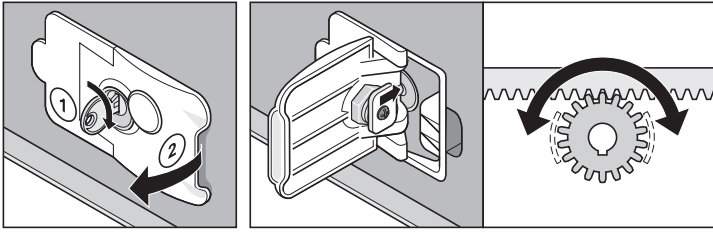

- Turn key (1) 90° to the right and pull the handle until it clicks into place: the operator will disengage and the door can be opened manually.

Stop for position gate CLOSED

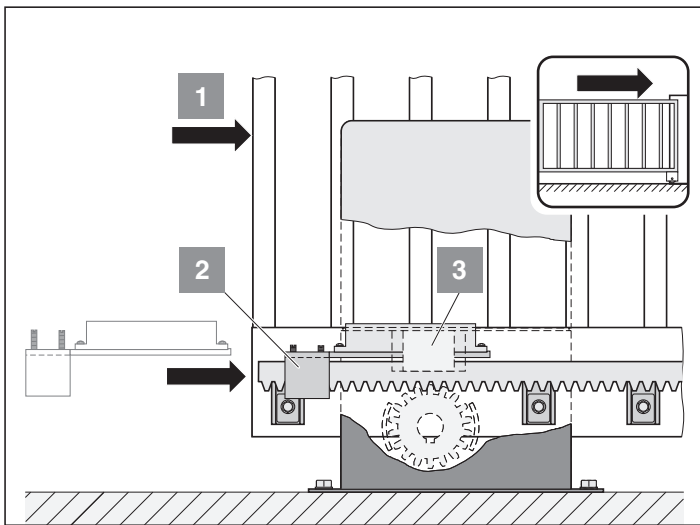

- Close gate until it is position CLOSED (1).
- Push end switch magnet (2) to magnet end switch (3) until it switches (LED is illuminated on the control unit).
- Firmly fasten the end switch magnet (2).

Stop at position gate OPEN

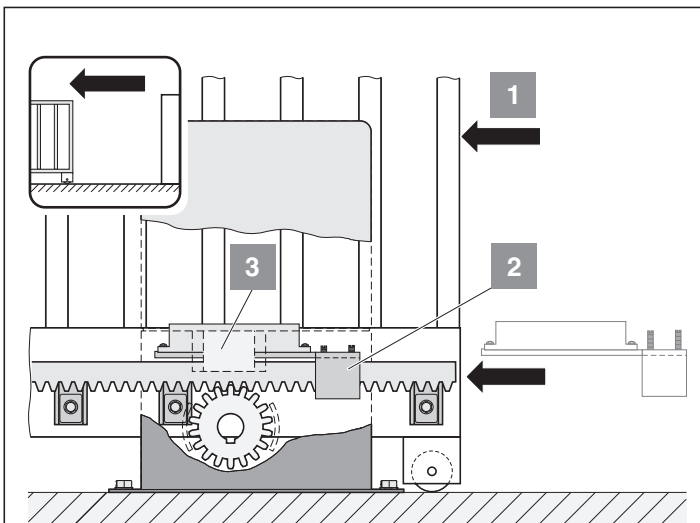

- Open gate until it is position OPEN (1).
- Push end switch magnet (2) to magnet end switch (3) until it switches (LED is illuminated on the control unit).
- Firmly fasten the end switch magnet (2).

Commissioning

Safety Instructions

i After the drive system has been installed, the person responsible for the installation must complete an EU Declaration of Conformity according to Machine Directive 98/37/EU and attach a CE mark at the type plate of the drive. This also applies in cases where the owner of the system is a private person, as well as to manually operated gates that have been upgraded with a drive. These documents as well as the Installation and Operating Instructions must be handed over to the owner of the gate system.

! The force settings are relevant for the system's safety and must therefore be adjusted with special care and attention. In the event of inappropriate force settings, there is a risk of damage to persons, animals and property. Adjust force settings to the lowest possible value to ensure that obstacles are immediately detected and the gate movement is stopped.

Teaching in of Drive

The control unit is equipped with an automatic force setting facility.

When the gate is opened or closed, the control unit automatically detects the force required and stores these values when the end position is reached..

- Locking of Drive

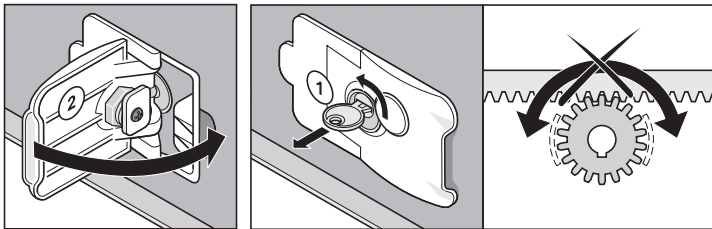

- Close lever (2) - turn key (1) anticlockwise by 90° and remove it.: The drive engages and the gate cannot be opened by hand.
- Move the gate by hand until it engages in the drive system (loud clicking noise).
- Activate the main switch.

Control System Reset

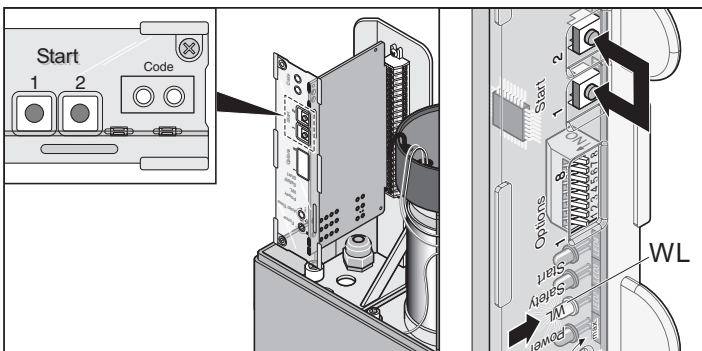

- Press and hold buttons (1+2) until the LED (warning lamp) is off
- Release buttons (1+2): LED (warning lamp) is flashing; force values are deleted.
- Closing of Gate

Complete the following procedure 2x:

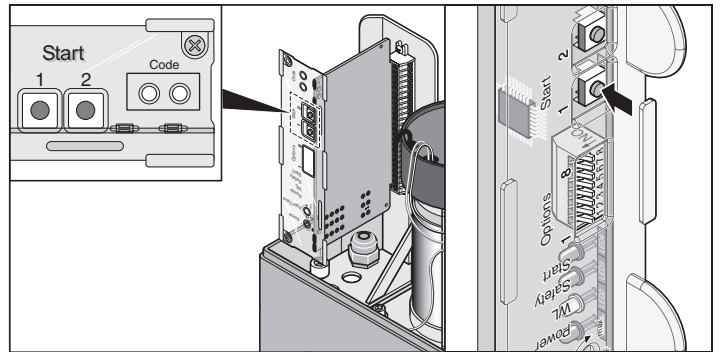

- Press button (1)
Gate opens until it reaches the end switch magnet (end position for gate OPEN)
- LED (warning lamp) is flashing
- Press button (1)
Gate closes until it reaches the end switch magnet (end position for gate OPEN)
- LED (warning lamp) is flashing
- LED (warning lamp) is on for a while and is then switched off; force values are saved.
- Check end positions for gate OPEN and CLOSED by repeatedly opening and closing the gate. If necessary, adjust end positions until the gate can be fully opened and closed.

i Soft run length for gate CLOSED min. 500 mm.

Check force settings

Each time the gate is operated, the control system checks whether the stored force values correspond to the actual values and automatically adjusts the settings when the end positions are reached.

For details on how to check the force values, refer to chapter "Maintenance and Servicing".

Teaching in of Hand-Held Transmitter

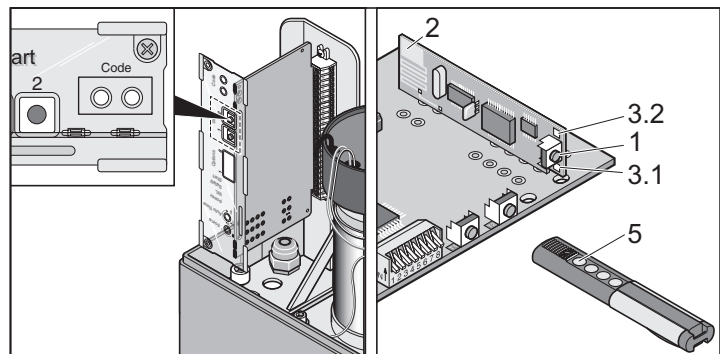

- Press teach-in button (1)
 - 1x for channel 1, LED (3.1) is on
 - 2x for channel 2, LED (3.2) is on
- Press desired button at the hand-held transmitter (5). The respective signal is transmitted to the radio receiver.
- LED is off - The teach-in process is completed.
- If no other code signal is transmitted within 10 seconds, the radio receiver switches to standard operation.
- Continue with teaching in all other hand-held transmitters by repeating the above procedure. The system caters for maximum 112 codes.

Operation

Safety Instructions

- Keep children, disabled persons and animals away from the gate.
- Keep your hands clear of the moving gate or any other moving parts.
- Only drive through the gate when it is fully opened.
- There is a risk of injury from being trapped or cut on the gate system's moving parts or edges.

Opening the Gate

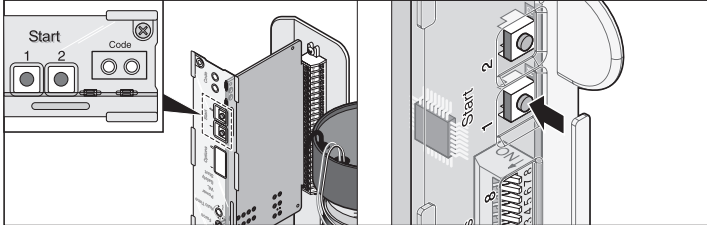

- Press push-button (1) or key at the hand-held transmitter 1x.
- If the gate is moving in direction OPEN, it is stopped. This function is determined by the settings of DIP switch 7.
- If the button is pressed again, the gate closes.

Closing of Gate

- Press push-button (1) or key at the hand-held transmitter 1x.
- If the gate is moving in direction CLOSED, it is stopped. This function is determined by the settings of DIP switch 7.
- If this button is pressed again the gate opens.

Pulse Sequence of Door Movement

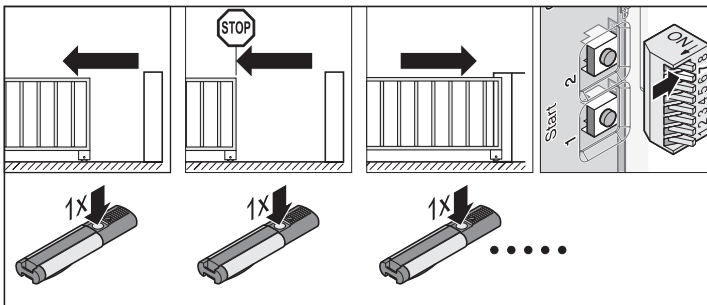

Default settings for all drives

- DIP 7 OFF:
 - open - stop - close - stop - open - etc.

Adjust pulse sequence with DIP switch 7.

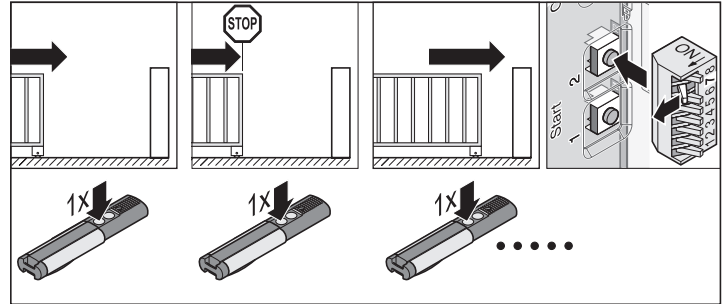
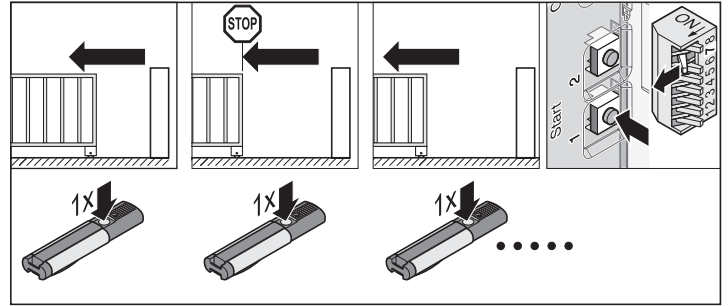

- DIP 7 ON:
 - button 1: open - stop - open - stop - etc.
 - button 2: close - stop - close - stop - etc.

Reset of Control System

All stored values (e.g. runtime, force for opening, etc.) are deleted. Subsequently, teach-in procedure must be repeated. A reset of the control system is required:

- if the maximum speed or the maximum force are to be adjusted (see TorMinal manual).
- if the drive settings are incorrect (incorrect teach-in) or if the gate has been modified.

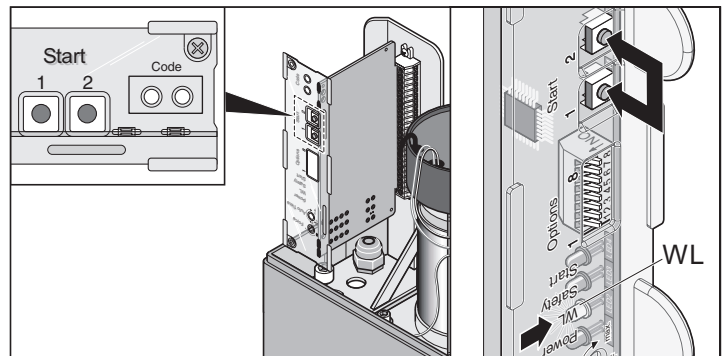

- Press and hold buttons (1 + 2) until the LED (warning lamp) is off
- LED (warning lamp) is off - the force values are deleted; release the buttons.

Operation

Emergency Release

⚠ Caution!
In the event of an emergency release, the gate might open/close automatically.

i The drive can be released anytime, irrespective of the position of the gate.

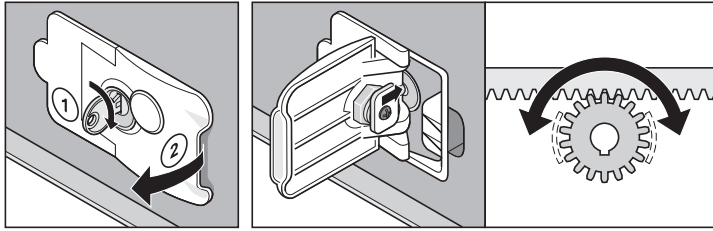

• Turn key (1) clockwise by 90° and pull lever (2) until it engages. The drive is now released and the gate can be moved by hand.

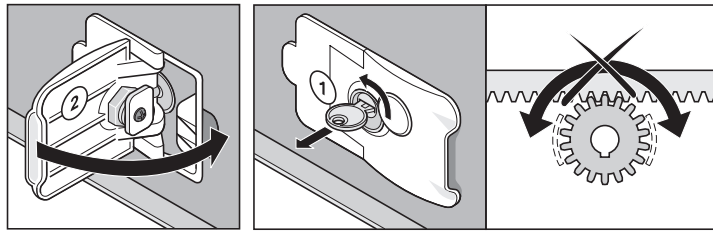

• Close lever (2) - turn key (1) anticlockwise by 90° and remove it.: The drive engages and the gate cannot be opened by hand.

Overload Protection

If an overload occurs while the gate is being closed or opened, the drive is immediately halted by the control system.

The overload protection is automatically reset after approx. 20 seconds or after a reset of the control system. The drive can again be operated normally.

Operation following a Power Failure

The force values remain saved even if a power failure occurs. The first movement of the unit following a power failure is always in direction OPEN.

Function of Button 2

For settings, see chapter "Functions and Connections".

2-channel operation (separate signals for closing and opening)

Press button 1 to open the gate; press button 2 to close the gate.

Partial opening

Press button 1 to fully open/close the gate. Press button 2 to open/close the gate partially.

Biased-off operation (activation only with TorMinal)

The gate opens, as long as button 1 is pressed. The gate closes, as long as button 2 is pressed.

Intermediate Stop

To halt the gate during travel, press the respective key at the hand-held transmitter. The drive system is halted immediately. At the next command, the drive operates in the opposite direction (see also chapter "Pulse Sequence and Gate Movement").

Stop forced by Obstacle

1. Force cut-off

- When gate closes -> drive direction is reversed
- When gate opens -> drive direction is reversed

At the next command, the drive operates in the opposite direction (see also chapter "Pulse Sequence and Gate Movement").

2. Safety input 1 triggered e.g. due to activation of safety contact strip

If the gate is halted by a signal at the safety input, the subsequent drive motion is determined by the DIP switch settings (see chapter "Obstacle Detection").

Factory Settings:

- When gate closes -> drive direction is reversed
- When gate opens -> drive direction is reversed

At the next command, the drive operates in the opposite direction (see also chapter "Pulse Sequence and Gate Movement").

3. Safety input 2 triggered e.g. due to triggering of light barrier

If the gate is halted by a signal at the safety input, the subsequent drive motion is determined by the DIP switch settings (see chapter "Obstacle Detection").

Factory Settings:

- When gate closes -> drive direction is reversed
- When gate opens -> drive is not restarted

At the next command, the drive operates in the opposite direction (see also chapter "Pulse Sequence and Gate Movement").

Functions and Connections

General Tips

- At delivery, all DIP switches are in OFF position.
- Do not apply any external voltage to the control connections, as this would completely destroy the system.

Overview of Control System

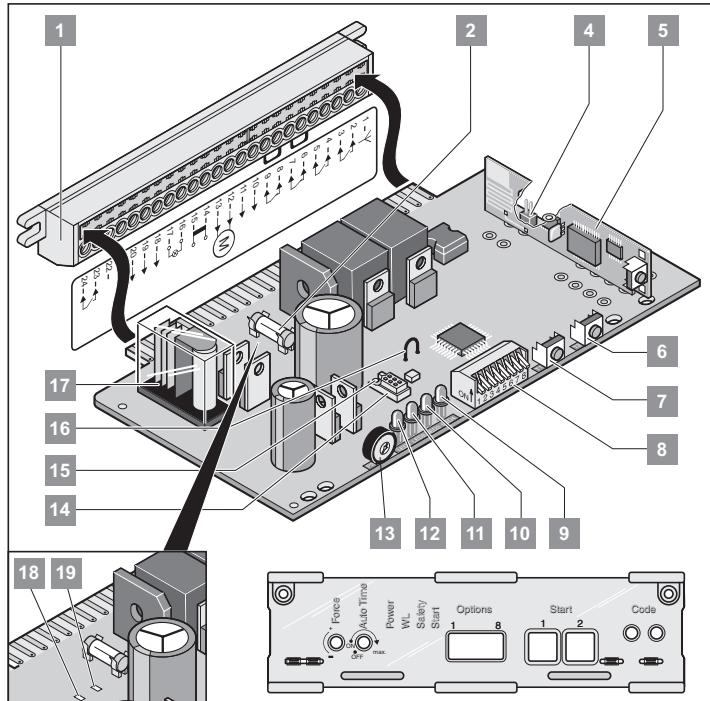

1. Terminal bar with 24 slots
2. Fuse of adapter for warning lamp 1, terminal 16 + 17
3. Free
4. Adapter for external antenna
5. Radio receiver
6. Button 2 (T2)
7. Button 1 (T1)
8. DIP switches 1 - 8
9. Start (LED 4)
is on when a radio code is transmitted or when a button is pressed.
10. Safety (LED 3)
is on when a signal is received through the safety input.
11. Warning lamp (WL) (LED 2)
is flashing when the gate is opening/closing.
12. Power (LED 1)
is on when the system is powered.
13. Potentiometer (P2) for timer settings of the automatic closing mode
14. Adapter for TorMinal
15. Protection against incorrect connection of TorMinal
16. Wire bridge; if cut, soft run is disabled.
17. Relay contact, terminal 23 + 24
18. LED, magnetic end switch gate OPEN, terminal 18
19. LED, magnetic end switch door CLOSED, terminal 19

DIP Switches 1 - 8

i Caution!
Prior to adjusting the DIP switch settings, disconnect control unit from the power supply. The new DIP switch settings are read by the system upon restart of the control unit.

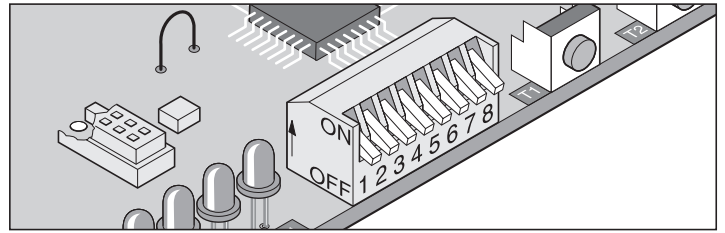

| Switch | Position | Function/response |
|---|----------|---|
| Safety input 1, terminal 6 + 7 | | |
| Behaviour of drive during opening of gate | | |
| 1 | OFF | No response from drive |
| | ON | Drive motion reversed |
| Safety input 1, terminal 6 + 7 | | |
| Selection of function: normally closed contact or 8.2 KOhm | | |
| 2 | OFF | Normally closed contact (e.g. light barrier) |
| | ON | 8.2 KOhm |
| Safety input 1 terminal 6 + 7, safety input 2 terminal 8 + 9 | | |
| Behaviour of drive during closing of gate | | |
| 3 | OFF | Drive is stopped and gate is opened a little (reversed motion) |
| | ON | Drive is stopped and gate is fully opened |
| Automatic close mode: The gate is automatically closed 5 seconds after the light barrier has been triggered (safety input 1 or 2). | | |
| 4 | OFF | deactivated |
| | ON | activated |
| Warning time for warning lamp input terminal 16 + 17 | | |
| 5 | OFF | Warning time 0 seconds |
| | ON | Warning time 3 seconds - warning lamp is flashing |
| Fraba system | | |
| 6 | OFF | deactivated |
| | ON | activated |
| Separate signals for closing and opening | | |
| 7 | OFF | Pulse sequence at 1st channel Button/radio channel 1 + 2: open - stop - close - stop - open - stop - close ... |
| | ON | Pulse sequence at 2nd channel Button/radio channel 1: open - stop - open ... Button/radio channel 2: close - stop - close ... |
| Partial opening | | |
| 8 | OFF | partial opening deactivated |
| | ON | partial opening activated - Button/radio channel 1 = open - stop - close ... - Button/radio channel 2 = partial opening DIP switch 7 OFF |

Functions and Connections

Radio Receiver

Safety Instructions

- Ensure that the installation and operation of the system complies with the applicable statutory safety regulations! For more information, contact the local electricity supplier, safety authorities and trade organisations.
- The operator of this radio-controlled equipment is not in any way protected against interference from other telecommunications systems and facilities (e.g. other radio-controlled equipment that is licensed to operate at the same frequency range).
- Poor reception might be eliminated by replacing the batteries of the respective hand-held transmitter.

Display and Buttons

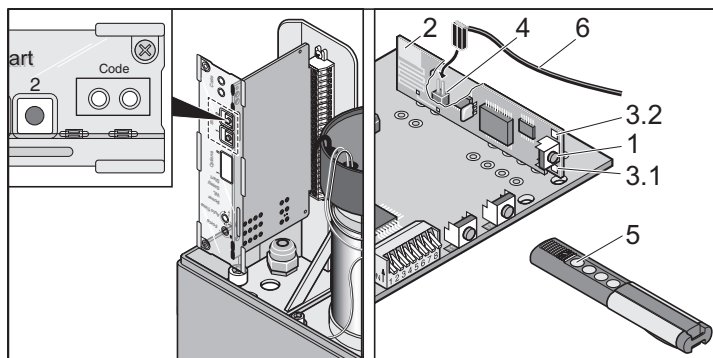

(1) Teach-in button

Press this button to select the required operating mode: teach-in mode, delete mode, standard mode

(2) internal antenna

i Radio channel 2 (3.2) is only used for 2-channel operation (separate channels for opening/closing or partial opening).

(3) LEDs indicate the channel that is currently selected.

3.1 LED of radio channel 1
3.2 LED of radio channel 2

(4) Adapter for external antenna (4)

If the range of the internal antenna is not sufficient for the proper operation of the gate, you have the option to connect an external antenna (see chapter "Accessories").

(5) Hand-held transmitter button

(6) External antenna

Teaching in of Hand-held Transmitter

- Press teach-in button (1)
 - 1x for channel 1, LED (3.1) is on
 - 2x for channel 2, LED (3.2) is on
- Press desired button at the hand-held transmitter (5). The respective signal is transmitted to the radio receiver.
- LED is off - The teach-in process is completed.
- If no other code signal is transmitted within 10 seconds, the radio receiver switches to standard operation.
- Continue with teaching in all other hand-held transmitters by repeating the above procedure. The system caters for maximum 112 codes.

Deleting of Assigned Radio Codes



If one of the gate users moves house and wishes to take the hand-held transmitter with him/her, all assigned radio codes must be deleted at the receiver.

For safety reasons, delete all buttons and button combinations of the hand-held transmitter!

- Press and hold teach-in button (1) for 5 seconds until at least one LED is flashing.
- Release teach-in button (1). The radio receiver is in delete mode.
- Press the button at the hand-held transmitter whose code you wish to delete. The LED is off and the respective code has been deleted from the radio receiver memory.

Repeat this procedure for all buttons and button combinations at the hand-held transmitter.

Deleting of Channels

- Press and hold teach-in button (1)
 - 1x for channel 1; LED (3.1) is on
 - 2x for channel 2, LED (3.2) is on.
- After 5 seconds, the LED begins to flash. After another 10 seconds, the LED is continuously on.
- Release the teach-in button (1). The selected channel has been deleted.

Deleting all Data in Radio Receiver Memory



If a hand-held transmitter has been lost, all channels at the radio receiver must be deleted for safety reasons! Subsequently, repeat the teach-in procedure for the receiver and all hand-held transmitters.

- Press and hold teach-in button (1).
- After 5 seconds, the LED begins to flash. After another 10 seconds, the LED is continuously on.
- After 25 seconds, all LEDs are on.
- Release the teach-in button (1). All channel data has been deleted.

Functions and Connections

Obstacle Detection (DIP 1, 2 + 3)

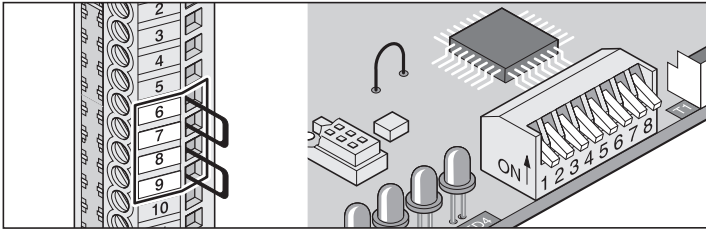

Obstacle detected while gate is opening

Force cut-off

Drive motion reversed

If a signal is received at one of the safety inputs (e.g. triggered by a person crossing the light barrier), the drive responds according to the settings of DIP switch 1.

Safety input 1, terminal 6 + 7

DIP switch 1:

OFF No response from drive
ON Drive motion reversed

DIP switch 2: Function of safety input 1, terminal 6 + 7

OFF Normally closed contact, e.g. for light barrier
ON 8.2 kOhm (safety contact strip)

Safety input 2, terminal 8 + 9

No response from drive

Obstacle detected while gate is closing

i If the gate is in automatic close mode, it is fully opened.

Force cut-off

Drive motion reversed

If a signal is received at one of the safety inputs (e.g. triggered by a person crossing the light barrier), the drive responds according to the settings of DIP switch 3.

Safety input 1, terminal 6 + 7

DIP switch 3:

OFF Drive is stopped and gate is opened a little; drive motion reversed
ON Drive is stopped and gate is fully opened

Safety input 2, terminal 8 + 9

DIP switch 3:

OFF Drive is stopped and gate is opened a little; drive motion reversed
ON Drive is stopped and gate is fully opened

Automatic Close Mode

i For operation with automatic close mode, comply with EN 12453 (e.g. installation of light barrier). An additional light barrier must be connected to safety input 2. This barrier responds only while the gate is being closed.

The gate closes automatically after the time for GATE OPEN set at the potentiometer has lapsed. The gate can be opened by means of a push-button or hand-held transmitter signal, but cannot be closed in this way.

While the gate is opening, it cannot be stopped by pressing a button. If a button is pressed while the gate is closing (automatic closing), it is fully opened. If a button is pressed during the set GATE OPEN time, the time is reset and the GATE OPEN time is restarted.

i Partial opening and automatic closing motion
Use both functions together, first partial opening (DIP 8 ON) and adjust the automatic closing motion thereafter.

The warning light connection 1 flashes during automatic closing motion.

Example:

- Warning light 1 connected to terminals 16 + 17.

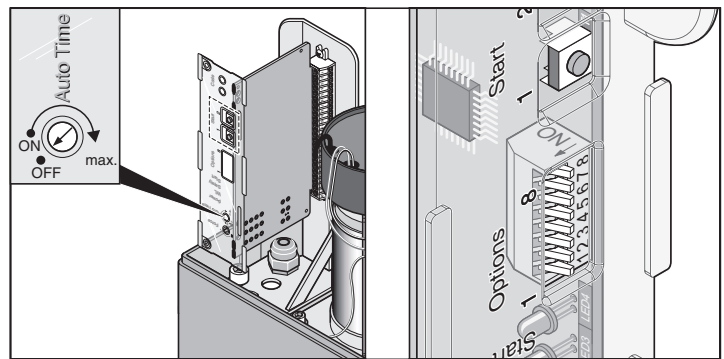

The GATE OPEN time can be adjusted at the potentiometer:

- Time adjustable between 1 and 120 seconds
- To deactivate function > turn key to left stop

Behaviour of the drive in the event of a signal at the safety inputs 1 + 2

While gate is opening:

Behaviour of the drive depends on the settings of DIP switch 1.

Beim Tor schließen:

While gate is closing:

The drive opens the gate fully, irrespective of the settings of DIP switch 3.

Option 1: Automatic close mode

Automatic closing is activated as soon as the end position gate OPEN is reached; at this moment, the GATE OPEN time set at the potentiometer is started. If another command is transmitted within the GATE OPEN time, the time is reset.

Settings:

- Set potentiometer to the required time (1 - 120 seconds)
- DIP switches 7 + 8 OFF
- Other DIP switches set as required

Functions and Connections

Option 2: Automatic close mode + light barrier (DIP switch 4)

i This option allows for the manual interruption of the closing motion, and for automatic closing after a set period of time after triggering of the light barrier.

The functions of option 1 apply. In option 2, the gate is automatically closed 5 seconds after the light barrier has been triggered (e.g. by vehicle passing through it). This option requires the connection of safety input 2, terminal 8 + 9.

Settings:

- Set potentiometer to the required time (1 - 120 seconds)
- DIP switches 7 + 8 OFF
- DIP switch 4 ON
- Other DIP switches set as required

Option 3: Automatic close mode + safety contact strip + light barrier

i This option allows for the manual interruption of the closing motion, and for automatic closing after a set period of time after triggering of the light barrier.

Similar to option 2, whereby the gate is automatically closed 5 seconds after the light barrier has been triggered.

- Safety contact strip to safety connection 1 (terminal 6 + 7).
- This option requires the connection of safety input 2, terminal 8 + 9.

Settings:

- Set potentiometer to the required time (1 - 120 seconds)
- DIP switches 7 + 8 OFF
- DIP switches 2, 4 ON
- Other DIP switches set as required

Warning Time (DIP 5)

A warning light connected to warning light connection 1 (terminal 16 + 17), flashes for 3 seconds after activation of the button, or activation of the hand transmitter, before the operator starts.

The drive is only activated after this period has lapsed. If another button is pressed in the meantime, the warning time is terminated.

DIP switch 5

OFF deactivated
ON activated, warning light 1 flashes for 3 seconds.

Fraba System (DIP 6)

You have the option to route the function of safety input 1 (terminal 6 + 7) to the signal interpretation of a Fraba system.

DIP switch 6

OFF deactivated
ON activated

Separate Signals for Closing and Opening (DIP Switch 7)

Button/radio channel 1: for opening, button/radio channel 2 for closing. The 2-channel mode is suitable for operation with 2 push-buttons or hand-held transmitters.

Settings: DIP switch 8 OFF, 2 buttons connected and/or 2 hand-held transmitter buttons programmed.

DIP switch 7

OFF deactivated
ON activated

Partial Opening (DIP 8)

This function allows for the partial opening of the gate.

Example:

You wish to open the gate to give access to pedestrians only. To open the gate partially with this function, you have the option to adjust the settings for control with 2 push-buttons or by radio code (hand-held transmitter, Telecodey, etc.).

DIP switch 8

OFF deactivated
ON activated, DIP switch 7 disabled

Partial opening by pressing 2 push-buttons

Install additional push-button and connect it as button 2 to terminal 4 + 5.

Push-button 1 opens the gate fully. If the gate has been opened partially by pressing button 2, it can be fully opened by pressing push-button 1.

Push-button 2 opens the gate partially, provided that the gate is first closed. If the gate has already been opened fully (push-button 1) or partially (push-button 2), it is closed when push-button 2 is pressed again.

Procedure:

1. Close gate.
2. DIP switch 8 ON: partial opening is activated
 - Leave DIP switch 8 in position ON; if it is set to OFF, the set partial opening is deleted.
3. Press push-button 2 (opening gate from position GATE CLOSED).
 - The gate opens until push-button 2 is pressed again or until the gate reaches the GATE OPEN position.
4. Press push-button 2 as soon as the desired position is reached.
5. To close the gate, press push-button 2 again.

The opening distance for partial opening has been programmed. Next time push-button 2 is pressed, the gate is opened partially according to these settings.

To delete the settings for partial opening: Set DIP switch 8 to OFF.

Partial opening by means of hand-held transmitter (2-channel operation)

Teach-in 2 buttons at the hand-held transmitter: e.g. button 1 assigned to radio channel 1 and button 2 assigned to radio channel 2

Radio channel 1 is assigned the same function as button 1, terminal 2 + 3,

Radio channel 2 is assigned the same function as button 2, terminal 4 + 5.

Proceed with programming as described above.

Functions and Connections

Terminal bar with 24 slots

- Permitted cable cross-section: max. 1.5 mm².

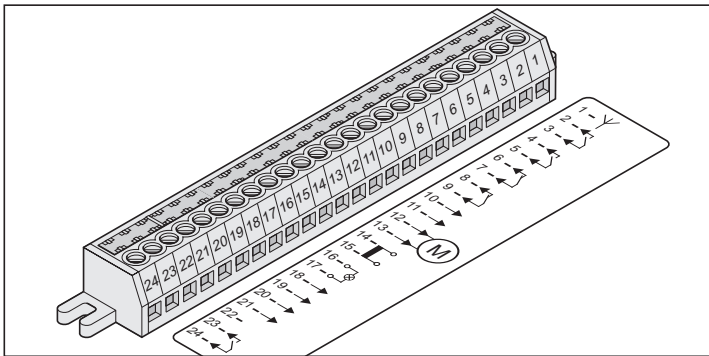

| Terminal | Assignment/colour | Connection/description |
|----------|-------------------|---|
| 1 | not assigned | Connection of antenna 40 MHz |
| 2 + 3 | not assigned | Push-button 1 |
| 4 + 5 | not assigned | Push-button 2 |
| 6 + 7 | Bridge | Safety input 1 (bridge) * |
| 8 + 9 | Bridge | Safety input 2 (bridge) * |
| 10 + 11 | not assigned | Regulated DC 24 V, max. 0,1 A |
| 12 | red | motor * |
| 13 | black | motor * |
| 14 + 15 | white | Transformer AC 24 V, secondary * |
| 16 + 17 | not assigned | Warning lamp 1, unregulated DC 24 V |
| 18 | green | magnetic end switch door OPEN * |
| 19 | white | magnetic end switch door CLOSED * |
| 20 | yellow | regulated DC 12 V * |
| 21 | brown | GND * |
| 22 | - | Reverse polarity protection |
| 23 + 24 | not assigned | Floating relay output AC 230 V, max. 5 A |

* Factory assignment

Connection to Power Supply

- Permitted cable cross-section: max. 2.5 mm².

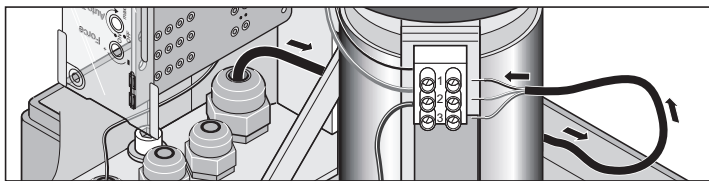

| Terminal | Colour of cable | Description |
|----------|-----------------|-----------------------------|
| 1 | brown | Live conductor (L) AC 230 V |
| 2 | brown | neutral conductor (N) |
| 3 | yellow/green | Earth conductor (PE) |

Connection of Push-Buttons

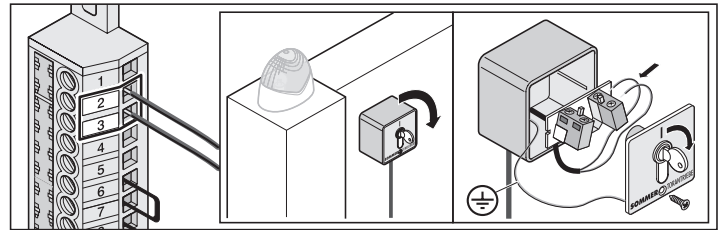

Push-button 1
Terminal 2 + 3

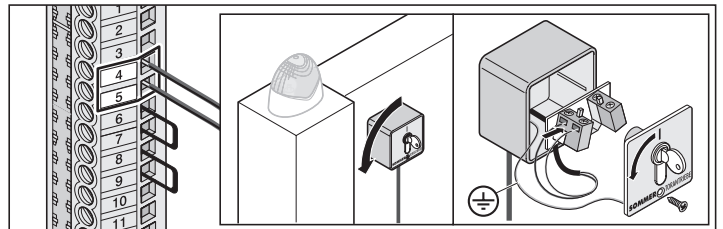

Push-button 2
Terminal 4 + 5

Push-button 2 is used if separate signals for opening and closing are to be defined, for the partial opening function and for biased-off operation of the buttons.

Connection of Fraba System

Connection without special analysis device; the signals are interpreted by the control system.

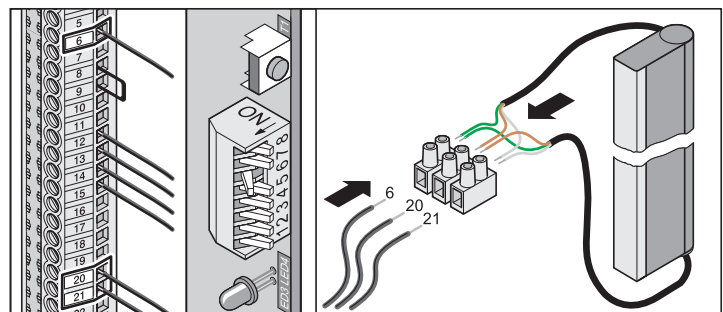

- Terminal 6: Connect green cable of Fraba system
- Terminal 20: Connect brown cable of Fraba system
- Terminal 21: Connect white cable of Fraba system

DIP switch 6 ON

Functions and Connections

Connection of Light Barrier

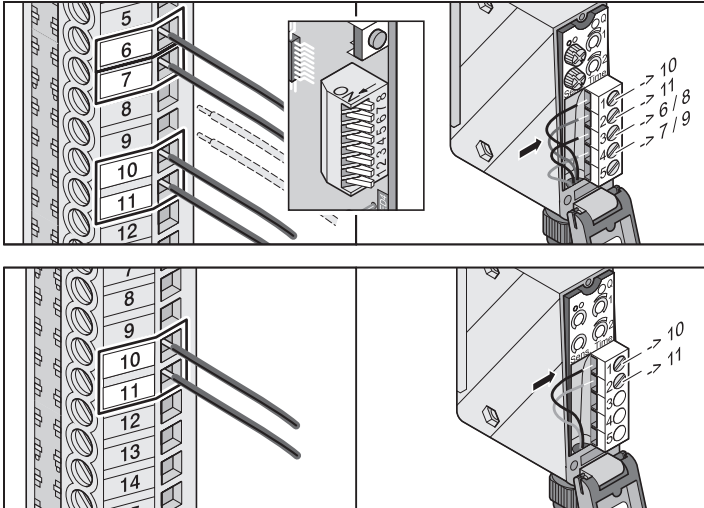

Safety input 1

Terminal 6 + 7: Tested adapter for floating contacts, provided that **DIP switch 2 is set to OFF**

Safety input 2

Terminal 8 + 9: Tested adapter for floating contacts, **responding only while gate is being closed**

Power supply

Terminal 10: Regulated DC 24 V, max. 0,1 A

Terminal 11: Earth

Connection of Safety contact strip

Analysis 8.2 kOhm. Connection without special analysis device; the signals are interpreted by the control system.

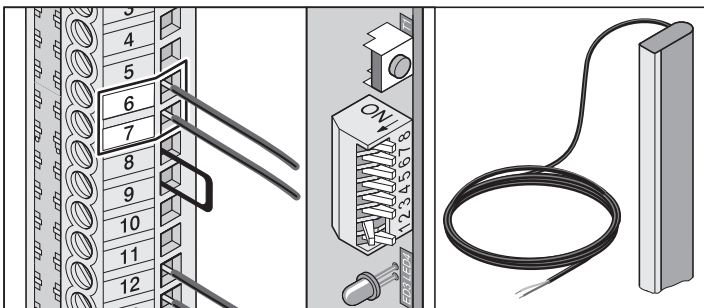

Terminal 6 + 7: Tested adapter for 8.2 kOhm resistor

DIP switch 2 ON

24 V Connection

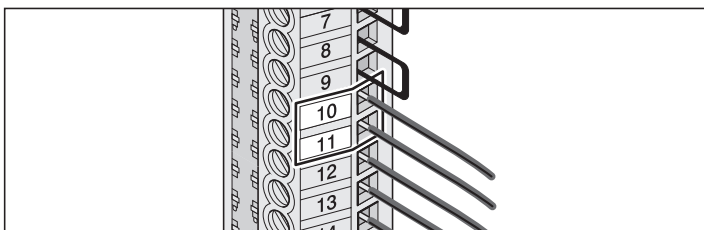

Terminal 10: Regulated DC 24 V, max. 0,1 A

Terminal 11: Earth

Motor

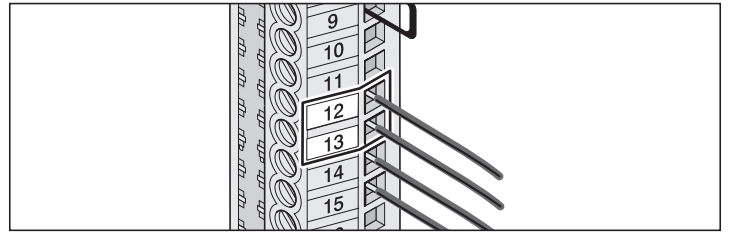

Terminal 12: red

Terminal 13: black

Exchange connections for drive mounted on the right-hand side.

Transformer

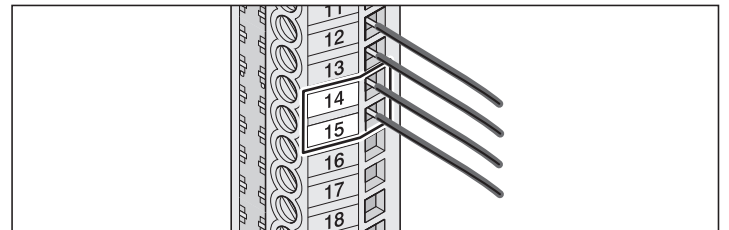

Klemme 14 + 15: Transformer cable (white), secondary connection
AC 24 V

Connection of Warning Lamps

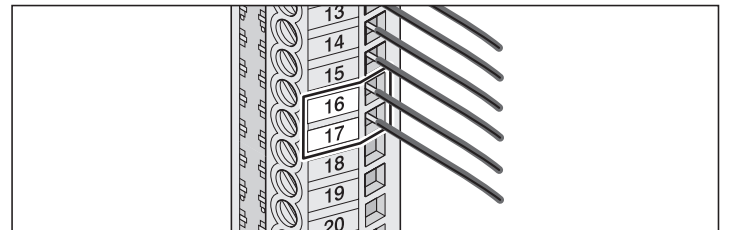

Warning lamp 1

Terminal 16 + 17: unregulated DC 24 V (max. 34 V) 25 Watt, max. 1 A
Protected with 1 A fuse, fast-acting.

12 V Connection

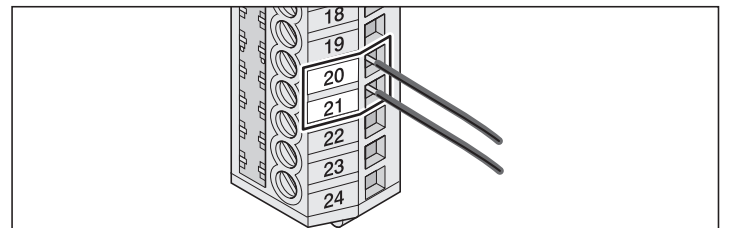

Terminal 20: DC 12 V, max. 0,1 A

Terminal 21: Earth

Functions and Connections

Floating relay output

Each time the drive is started, a pulse is present at the relay output with which, for instance, stairway lighting can be switched on via an automatic switching system.

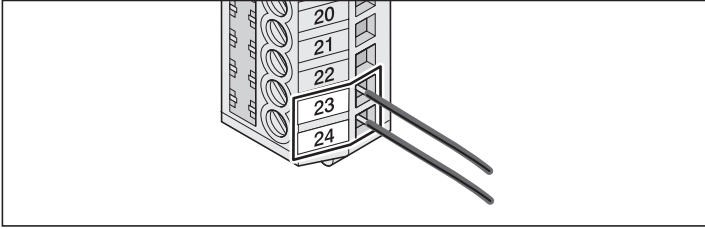

Terminal 23 + 24 AC 230 V, max. 5 A

To change settings, use TorMinal.

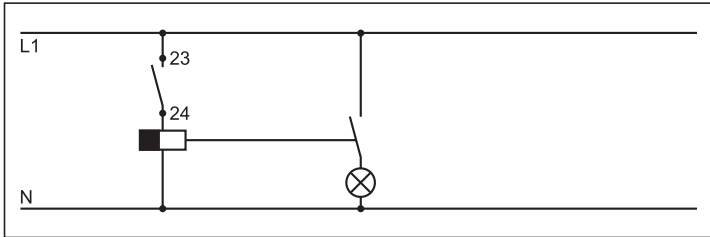

Example: Staircase lighting with automatic switching system

Connection of External Antenna

Please refer to chapter "Accessories"

TorMinal Interface

Please refer to TorMinal operating manual

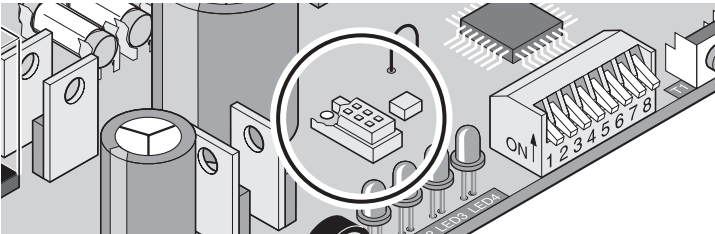

Special Functions

Biased-off operation

Maintenance monitoring

These and other functions and modes can only be activated/configured with TorMinal.

Accessories

1. Warning Lamp

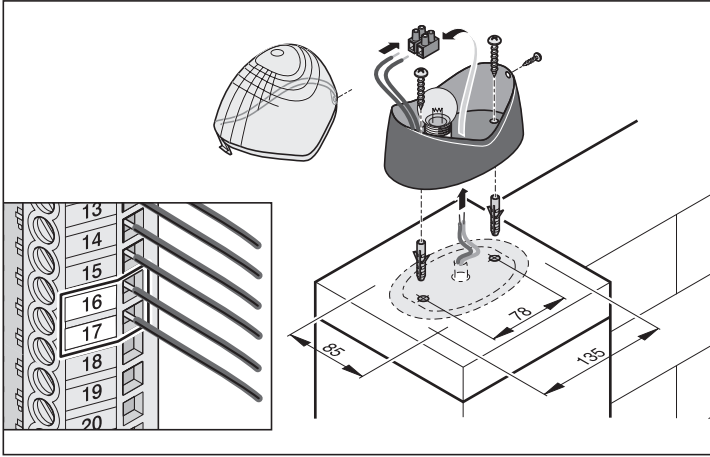

2. Key Switch

⚠ Position the key switch box in such a way that the operator can see the gate, while he/she is not inside the operating area of the gate.

- Never lead the key switch cable along the power line, as this could lead to interference in the control system.
- Use a separate conduit for the key switch line.

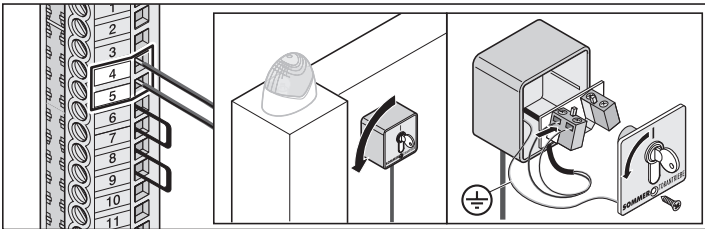
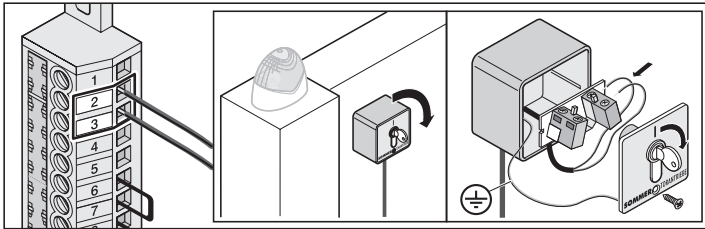

- Install key switch box at a suitable location that can be easily accessed.

3. Light Barrier

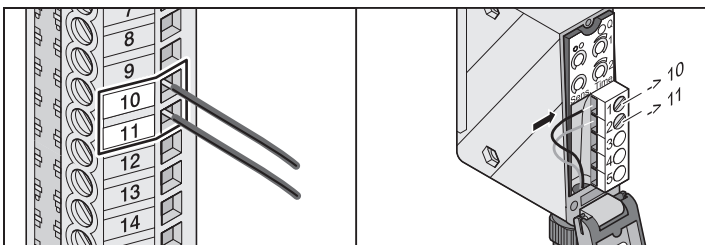
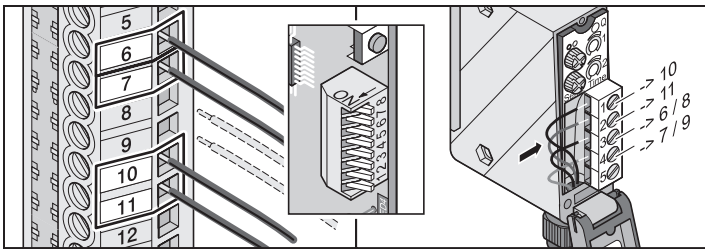

4. Base frame

i For installation, observe dimensions and correct angles (see chapter "Location of Installation").

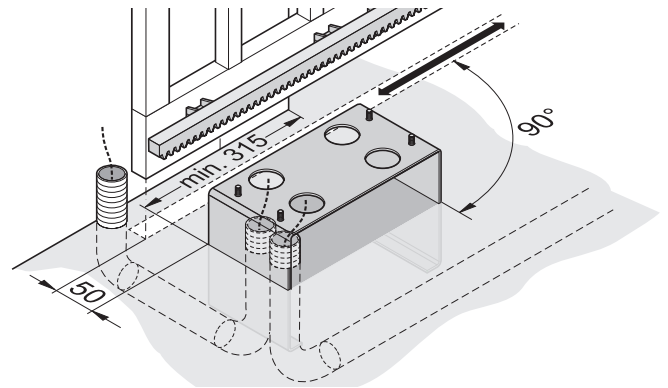

- When completing the foundation, take into account the dimensions of the base frame and cable conduits (for light barrier, etc.). For more details, please refer to chapter "Foundation".
- Check dimensions and level alignment of base frame. Embed conduits and base frame in concrete.

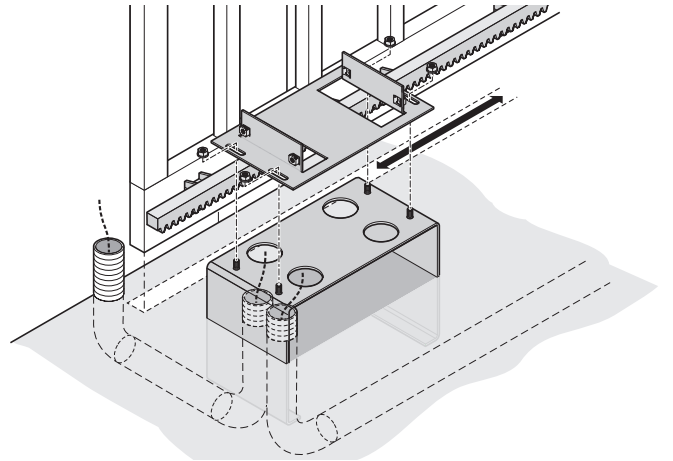

- Secure anchor plate onto the base frame.

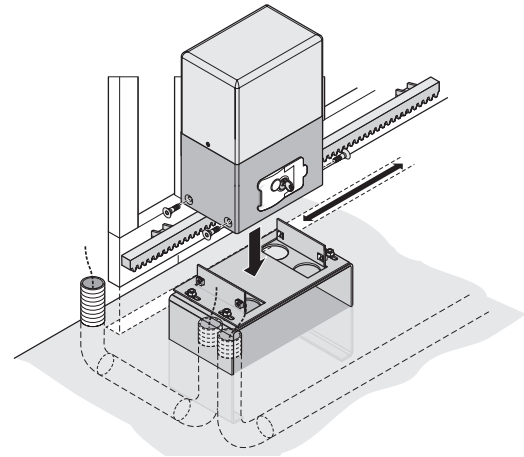

- Position drive onto the anchor plate and secure with screws.
- Insert cables.

Accessories

5. Main Switch

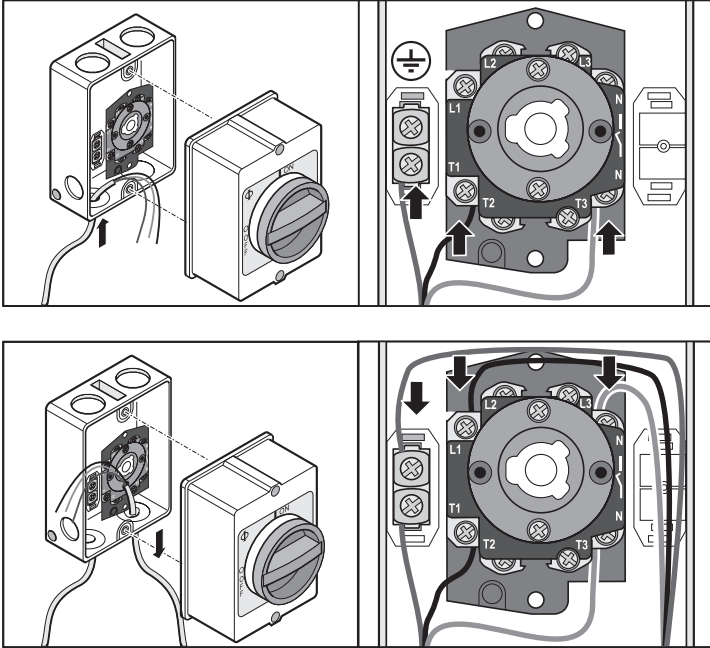

6. External Antenna

- If the internal antenna is not sufficient for the proper operation of the gate, you have the option to connect an external antenna to the system.
- Ensure that the antenna cable is laid in such a way that there is no physical impact to the radio transmitter. Install tension protection, if necessary.
- Consult the operator/owner of the system in order to find a suitable location for the external antenna.

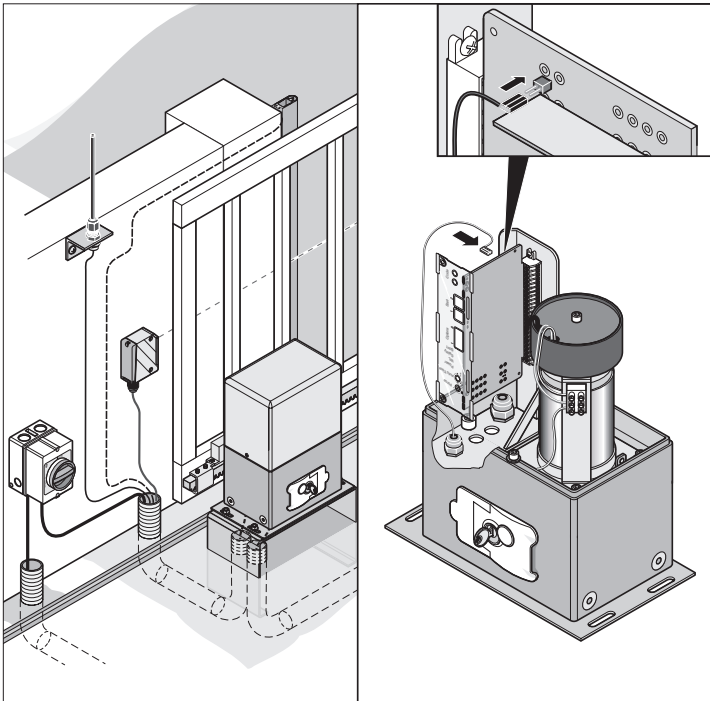

- Connect external antenna to the respective adapter.

7. Safety contact strip

i You can either connect the 8,2 kOhm or the Fraba bar, but not both together.

8,2 kOhm

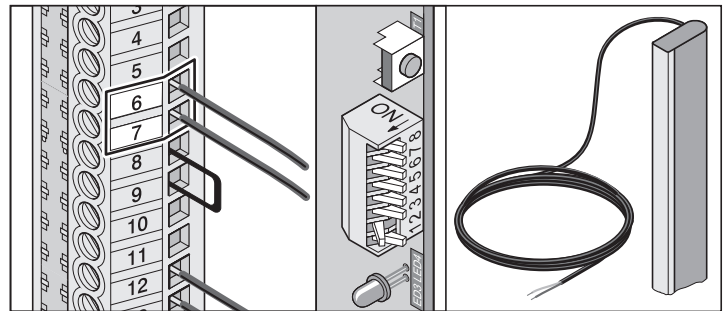

Klemme 6 + 7 Tested adapter for 8.2 kOhm resistor

DIP switch 2 ON

Fraba system

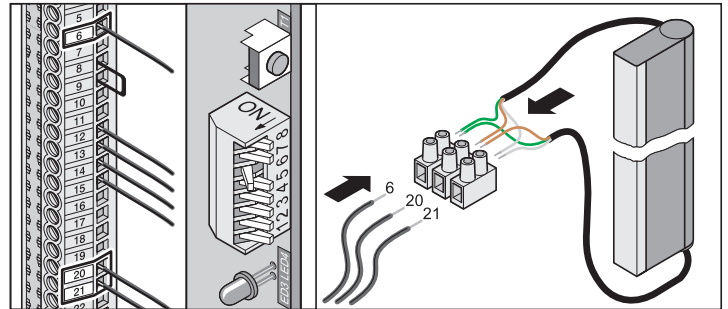

Terminal 6: Connect green cable of Fraba system

Terminal 20: Connect brown cable of Fraba system

Terminal 21: Connect white cable of Fraba system

DIP switch 6 ON

Maintenance and Servicing

Important Information



Never clean the drive system with a pressure hose.

- Prior to carrying out any work on the drive system, disconnect it from the power supply and secure it against inadvertent switching on.
- Never clean the drive with alkaline or acidic solutions.
- Clean drive only with a dry cloth.
- Keep your hands clear of the moving gate or any other moving parts.
- There is a risk of injury from being trapped or cut on the gate system's moving parts or edges.
- All fixing screws on the drive must be regularly checked and retightened if necessary.
- The gate must be regularly inspected in accordance with the manufacturer's instructions.

Regular Inspection

All safety-relevant devices must be inspected and tested on a regular basis, at least once every year (Examples of available accessories: BGR 232 formerly ZH 1/494).

Safety devices that are sensitive to pressure (e.g. safety contact strip) should be checked every four weeks to ensure proper operation (see pr EN 60335-2-95).

| Test/inspection | Behaviour of gate/drive | yes/no | Possible cause | Remedy |
|--|---|--------|---|--|
| Force cut-off Stop gate wing during closing operation by placing a 50 mm wide object in its path. | Drive reverse gate motion when stopped by an obstacle | yes | • Force cut-off works properly | • Do not change settings. |
| | | no | • Force tolerance value too high; readjust with TorMinal • Gate settings incorrect | • Reduce force tolerance until test is successful. Prior to test, open and close the gate twice watching its operation. For more details, see TorMinal manual. • Adjust gate settings, consult specialised technician! |
| Emergency release For detailed instructions, see chapter "Emergency Release". | The gate must open/close easily when operated by hand. (gate properly balanced) | yes | • Everything OK! | |
| | | no | • Emergency release defective • Gate jammed | • Repair emergency release device • Inspect gate and test gate operation (see operating manual of gate). |
| Safety contact strip (optional) Open/close gate and interrupt motion by triggering the safety contact strip. | Gate behaviour according to settings of DIP switches 1, 2 and 3. LED "Safety" is on | yes | • Everything OK! | |
| | | no | • Cable defective, terminal screw loose • DIP switch settings incorrect • Contact unit defective | • Inspect wiring, retighten terminal screws • Readjust DIP switches • Shut down unit and secure against inadvertent switching on. Contact customer service department! |
| Light barrier (optional) Open/close gate and interrupt motion by triggering the light barrier. | Gate behaviour according to settings of DIP switches 1, 2 and 3. LED "Safety" is on | yes | • Everything OK! | |
| | | no | • Cable defective, terminal screw loose • DIP switch settings incorrect • Light barrier dirty • Light barrier incorrectly aligned (bracket bent or damaged) • Light barrier defective | • Inspect wiring, retighten terminal screws • Readjust DIP switches • Clean light barrier Readjust light barrier components • Shut down unit and secure against inadvertent switching on. • Contact customer service department! |

Maintenance and Servicing

Replacement of Fuses

- Disconnect system from the power supply.

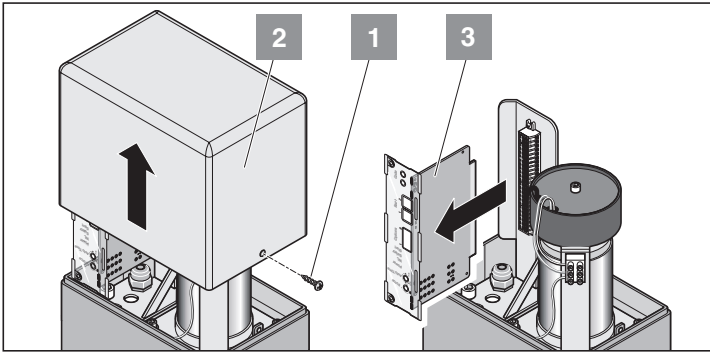

- Loosen screws (1). Remove cover (2).
- Pull out control unit (3).
- All fuses 1 A, fast-acting

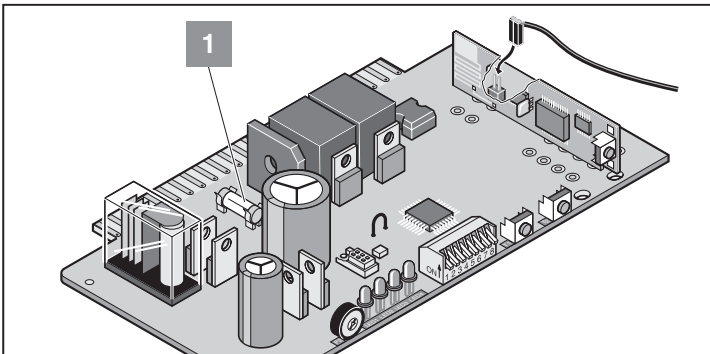

1. Fuse for connection of warning lamp 1, terminal 16 + 17

Additional Information

Disassembly

 Observe safety instructions!

The sequence of procedures for disassembly corresponds to that described in chapter "Installation", whereby the instructions must be followed in reverse order. The setting procedures described are not applicable.

Disposal

Comply with applicable statutory regulations!

Warranty and After-Sales Service

The warranty complies with the statutory requirements. Claims under warranty must be made to your stockist. Warranty entitlements are limited to the country in which the drive has been purchased. Batteries, fuses and bulbs are not covered by warranty.

If you require after-sales service, spare parts or accessories, please contact your specialist stockist.

When compiling these installation and operating instructions, we have endeavoured to outline procedures and instructions as clearly and comprehensibly as possible.

We have tried to make the installation and operating instructions as clear as possible. If you have suggestions for a better format, or if information is missing in the installation and operating instructions, then please send us your suggestions:

Fax.: 0049 / 7021 / 8001-403

email: doku@sommer-torantriebe.de

EU Declaration of Conformity

The company

SOMMER Antriebs- und Funktechnik GmbH
Hans-Böckler-Str. 21-27
D-73230 Kirchheim unter Teck

herewith declares that the product named below, if operated properly, conforms to the general requirements according to Article 3 of the R&TTE Directive 1999/5/EC and fulfils the requirements of the standards listed below:

Product: RF Remote Control for Doors & Gates

Type: RMO4-868-2, RM03-868-4, RX01-868-2/4, RFSDT-868-1, RFSW-868-1, RM02-868-2, RM06-868-2, RM04-868-1, RM02-868-2-TIGA, RM08-868-2, RM01-868, RM02-434-2, Rm03-434-4, RM04-434-2

Applicable guidelines and standards are:

- ETSI EN 300220-1:09-2000, -3:09-2000
- ETSI EN 301489-1:07-2004, -3:08-2002
- DIN EN 60950-1:03-2003

Kirchheim, 04.08.2004
Frank Sommer
Managing Director



Troubleshooting

Additional Tips for Troubleshooting

i Many problems can be solved by a control reset (deletion of force values) and subsequent reprogramming of the drive!

Should you be unable to identify and eliminate a fault using this table, please take the following steps:

- Disconnect any accessories (e.g. light barrier) connected to your system
- Reset all DIP switches to the default settings
- Reset all potentiometers to the default settings
- Carry out a reset of the control system (deletion of set force values)
- If settings have been changed with TorMinal, carry out a reset of the control system using TorMinal.
- Check all connections at the direct plug-type adapters and the terminal strip, and retighten them, if necessary.

The most common defects and errors can be eliminated by following the instructions in the table below. If you need further assistance, contact your dealer for advice.

| Fault/disruption | Possible cause | Remedy |
|--|--|--|
| Gate cannot be opened or closed | Unit is not powered, LED "Power" is off | Check fuses and power supply lines Activate main switch Install control system |
| | No control system installed | Replace fuse |
| | Fuse of circuit has triggered; LED "Power" is off | Check power supply by connecting a different device (e.g. power drill) |
| | Control system is not correctly installed | Ensure that the control unit is properly connected to the terminal strip |
| | Automatic close mode is activated | Gate closes automatically, after the set time has lapsed Deactivate automatic close mode, turn potentiometer in anticlockwise direction to the stop Remove obstacle in the light barrier |
| | Light barrier has been triggered, LED "Safety" is on | Remove obstacle in the light barrier |
| | Safety contact strip (8.2 kOhm) defective or DIP switch 2 set to OFF, LED "Safety" is on | Replace safety contact strip or set DIP switch 2 to ON |
| Gate cannot be opened or closed by means of the hand-held transmitter or Telecody | Fraba system activated, while light barrier or safety contact strip (80.2 kOhm) is connected, LED "Safety" is on | Disable Fraba system, set DIP switch 6 to OFF. |
| | Battery empty, LED at hand-held transmitter is off | Replace battery |
| | Teach-in of hand-held transmitter/Telecody not completed | Teach in hand-held transmitter/Telecody |
| | Incorrect radio frequency | Check frequency |
| Gate cannot be opened or closed by pressing the push-button/activating the key switch | Signal is continuously transmitted, as the button is jammed; LED "Start" and LED at the receiver are on | Release button or replace hand-held transmitter/Telecody |
| | Push-button not connected or defective LED "Start" is off while push-button is pressed | Check push-button connection or replace push-button |
| Gate stops during closing operation, moves approx. 10 cm in the opposite direction and stops | Continuous signal received - water in push-button housing; LED "Start" is on | Replace push-button and protect against the elements |
| | Force cut-off has been triggered by an obstacle | Remove obstacle, open gate fully |
| | Incorrect force value, or force tolerance too small | Delete force values and repeat teach-in procedure; if the error persists, increase force tolerance value. |
| | End switch magnet installed incorrectly, gate moves to jam | Readjust the end switch magnet, (see chapter "Positioning of Stops") |
| | Gate settings incorrect, or gate defective | Contact specialist for readjustment or repair of gate |

Troubleshooting

| Fault/disruption | Possible cause | Remedy |
|---|---|---|
| Gate stops during opening operation, moves approx. 10 cm in the opposite direction and stops | Force cut-off has been triggered by an obstacle | Remove obstacle Close gate completely using the push-button. |
| | Incorrect force value, or force tolerance too small | Delete force values and repeat teach-in procedure; if the error persists, increase force tolerance value. Only possible with TorMinal, refer to TorMinal manual |
| | End switch magnet installed incorrectly | Readjust the end switch magnet, (see chapter "Positioning of Stops") |
| Gate stops during opening | Light barrier triggered and DIP switch 1 set to ON | Remove obstacle in light barrier or set DIP switch 1 to OFF |
| Drive fails to close the gate | Power supply to light barrier disrupted | Check power line Replace fuse |
| | Drive was disconnected from power supply | At the first command transmitted after the unit has been connected to the power supply, the gate always opens fully. |
| Drive opens the gate, but no subsequent response to command from push-button or hand-held transmitter | System triggered through safety input (e.g. light barrier defective) LED "Safety" is on | - Remove obstacle from light barrier - Repair light barrier - Control system not properly installed |
| Connected warning lamp is off | Fuse defective Bulb defective | Replace fuse (see chapter "Maintenance and Servicing") Replace bulb |
| The gate moves at different speeds when opening/closing | Drive starts at normal speed, speed is reduced near the end position | No error; upon startup, the drive operates at maximum speed. Prior to reaching the end position, the speed is automatically reduced (soft run function). |
| The gate can only be operated, as long as the button/key switch is pressed. The inside light is flashing (biased-off operation) | Biased-off mode activated | Deactivate biased-off mode (see TorMinal manual) |
| "Start" LED is continuously on | Continuous signal at key connection 1 or 2. | Check connected switch (and key switch, if connected). |
| | Permanent signal from radio receiver, LED 3.1 or 3.2 at the radio receiver are on. Radio signal is being received; a remote control key might be defective or an external signal is received. | - Remove battery from the radio control device. - Wait until the external signal ceases. |
| Radio receiver only! | | |
| All LEDs are flashing | All memory positions are occupied (max. 112 positions) | - Delete the data of all radio control devices that are not in use. - Install additional radio receiver. |
| LED 3.1 or 3.2 is continuously on | Radio signal is being received; a remote control key might be defective or an external signal is received. | - Remove battery from the radio control device. - Wait until the external signal ceases. |
| LED 3.1 or 3.2 is on | Radio receiver is in programming mode and expects a code signal from a remote control device. | Press desired remote control key |

Spare Parts List

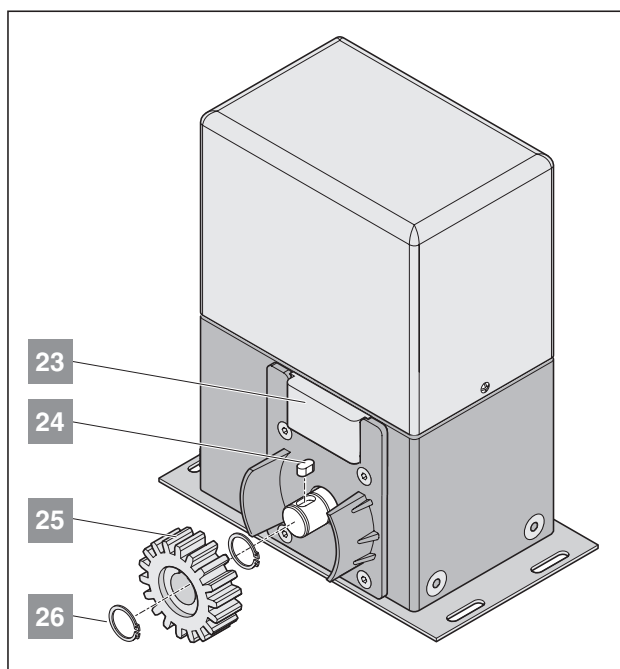
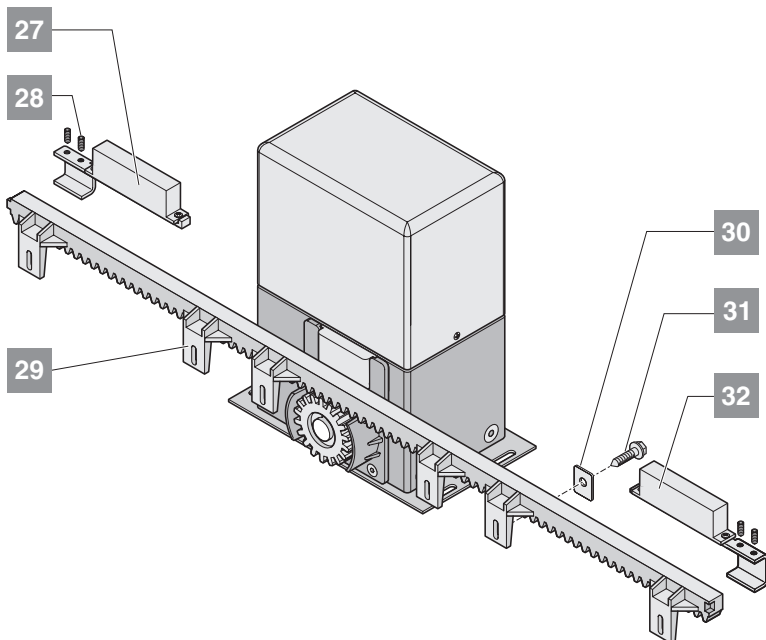
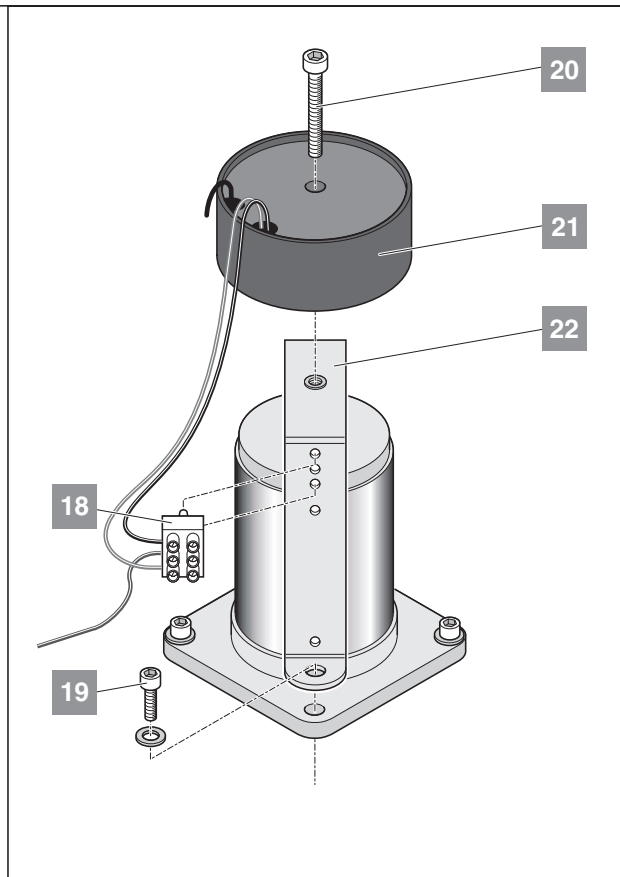
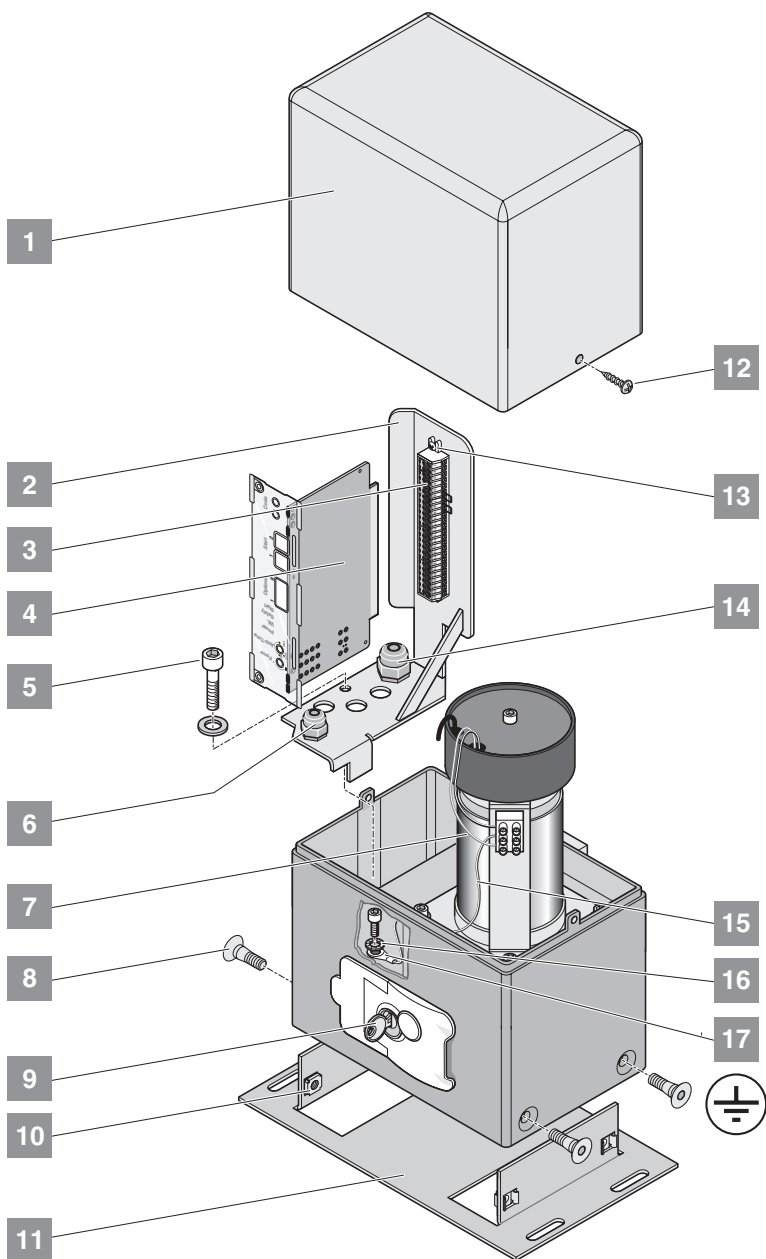

Spare Parts List

| Item no. | Description | Product no. | Quantity | Comment |
|----------|----------------------------|--------------|----------|---|
| 1 | Cover | 3411-001 | 1 | |
| 2 | Bracket for control system | 12302 | 1 | |
| 3 | Terminal bar, 24-pole | 12312V000 | 1 | |
| 4 | Control system | 3460V000 | 1 | including bracket with type plate |
| 5 | Screw M6 x 30 | 31123 | 1 | |
| 6 | Verschraubung M16 | 30015 | 4 | |
| | Screw set M 16 | 30017 | 4 | |
| 7 | Motor | 3411-007 | 1 | |
| 8 | Screw M8 x 20 | 3411-008 | 4 | |
| 9 | Key | 5820-032V005 | 2 | |
| 10 | Thread insert M8 | 3411-010 | 4 | |
| 11 | Anchor plate | - | 1 | |
| 12 | Screw 3,9 x 13 | 3411-012 | 2 | |
| 13 | Screw M3 x 8 | 13518 | 2 | |
| 14 | Screw connection M20 | 30016 | 1 | |
| | Lock nut M20 | 30018 | 1 | |
| 15 | Litz wire yellow/green | 12305 | 1 | |
| 16 | Screw 4,2 x 13 | 10009 | 1 | |
| 17 | Tooth-lock washer 6,2 | 31122 | 1 | |
| 18 | Terminal 3-polig | 12304 | 1 | |
| 19 | Screw M6 x 30 | 31123 | 4 | included in delivery of item 7 |
| 20 | Screw M5 x 55 DIN912 | 41067 | 1 | |
| 21 | Transformer | 12309V000 | 1 | |
| 22 | Bracket for transformer | 12301 | 1 | |
| 23 | End switch magnet | 5820-063 | 1 | |
| 24 | Parallel key 8x7x15 | 5820-020 | 1 | |
| 25 | Toothed wheel module 4 | 5820-018 | 1 | |
| 26 | Seeger retaining ring | 5820-019 | 2 | |
| 27 | End switch magnet right | 5820-060 | 1 | |
| 28 | Setscrew M6 x 20 | 3411-036 | 4 | |
| 29 | Rack 1m | 5829 | 4 | including securing material items 30 + 31 |
| 30 | Washer | - | - | included in delivery of item 29 |
| 31 | Screw | - | - | included in delivery of item 29 |
| 32 | End switch magnet left | 5820-061 | 1 | |
| - | Fixing panel | 5820-070V000 | 1 | incl. Pos. 8, 10, 11 |

Glossary

| | | |
|------------------------|--|--|
| Area of movement | | Area through which the gate moves when operated; the gate might thereby collide with persons, animals or objects located in the area of movement. |
| Main closing edge | | Edge of the gate wing whose position determines the opening width between the door stop (opposite closing edge) and the gate wing. |
| Secondary closing edge | | All closing edges at the gate wing except the main closing edge and opposite closing edge |
| Force tolerance | | Tolerance range of the programmed force; the drive might operate the gate with a force that is within this tolerance range. |
| Soft run | | Movement at minimum drive speed. |
| Intermediate stop | | If a command is issued while the gate is in motion (opening or closing), the drive is stopped. At the next command, the drive moves the gate in the opposite direction |
| TorMinal | | Programming device that allows for the adjustment of all gate drives and the activation of special functions. |

Gate operators

Swing gate operator twist 200 ...

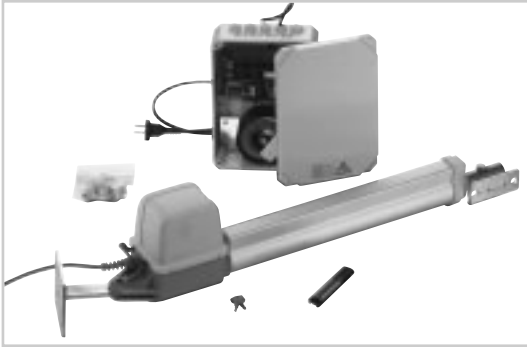

Garage door operators marathon / sprint ...

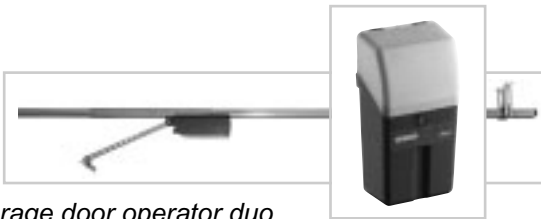

... Garage door operator duo ...

Radio technology



... Telecody ...



... Holder for hand-transmitter...



... Interior push-button ...

... Radio receiver with connecting cable ...



Operators for roller shutters and awnings



... Tube motors (mechanical or electronic end switches) ...

... Control system ...



... Wall-mounting bracket, removable ...

Accessories

... Light barriers ...



... Main switch ...

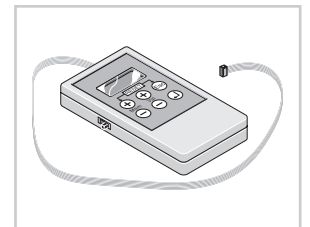

... TorMinal ...

... Warning lamp, 24 V ...



... and much more.