

Metro 800 RTS

Metro 1000 RTS

- PL** INSTRUKCJA MONTAŻU - ILUSTRACJE
- EN** INSTALLATION MANUAL - ILLUSTRATIONS
- DE** IINSTALLATIONSANLEITUNG - ABBILDUNGEN
- FR** MANUEL D'INSTALLATION - ILLUSTRATIONS
- IT** MANUALE D'INSTALLAZIONE - ILLUSTRAZIONI
- NL** INSTALLATIEGIDS - ILLUSTRATIES
- RU** РУКОВОДСТВО ПО УСТАНОВКЕ - ИЛЛЮСТРАЦИИ
- CS** NÁVOD K MONTÁŽI - OBRÁZEK
- NO** MONTERINGSANVISNING - ILLUSTRASJONER
- FI** ASENNUSOPAS - KUVITETTU
- SV** INSTALLATIONSANVISNING - BILDER
- DA** INSTALLATIONSVEJLEDNING - ILLUSTRATIONER

Ref. 5128442A



WIŚNIEWSKI powered by **somfy**®

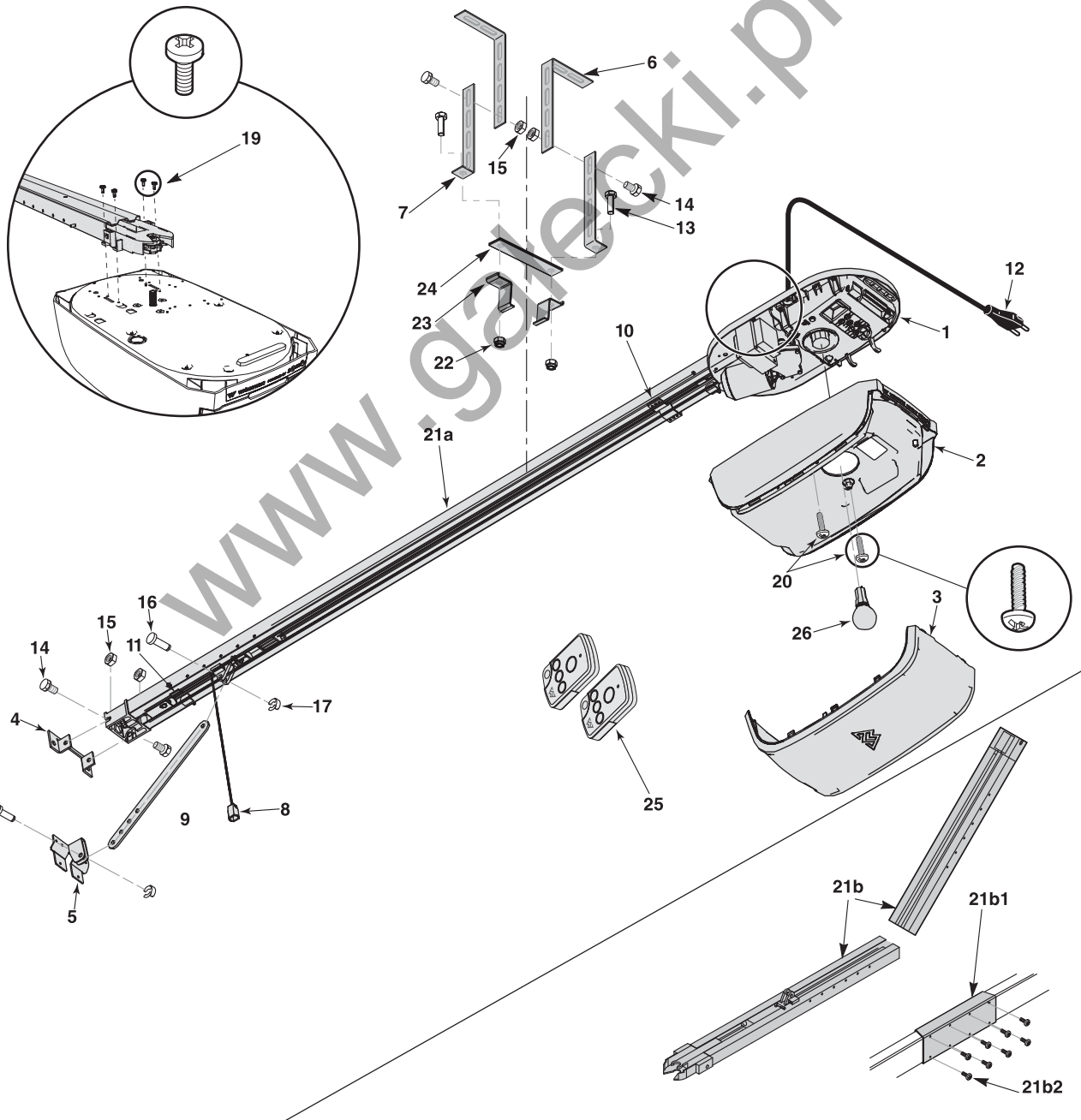
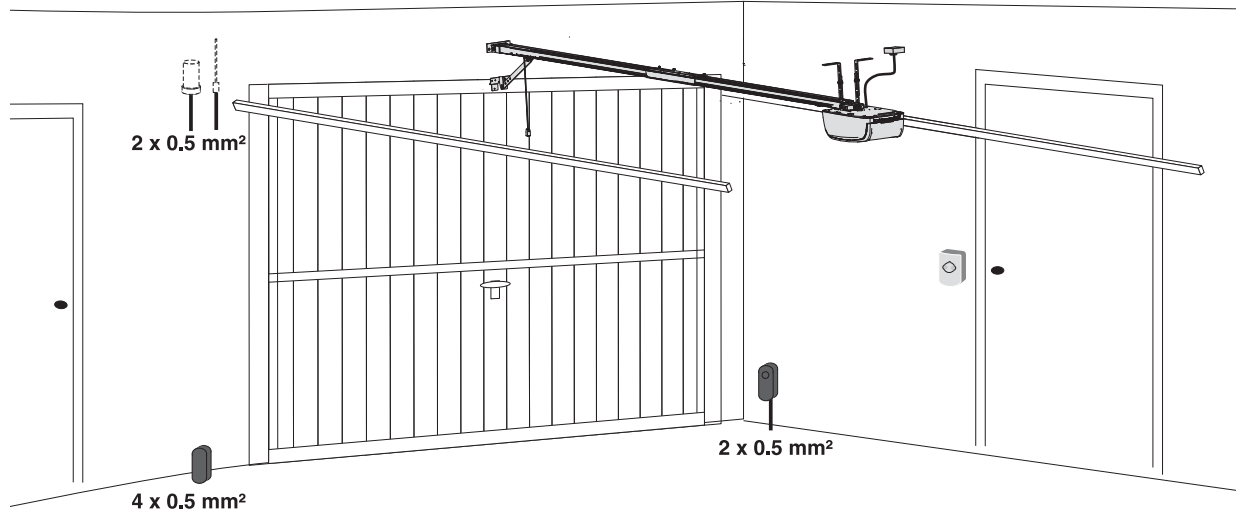

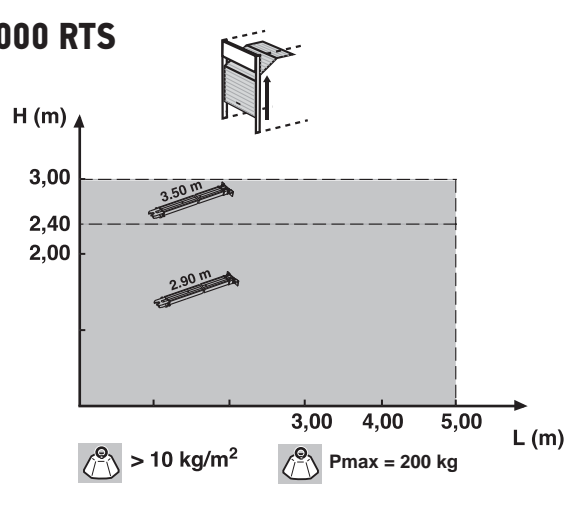
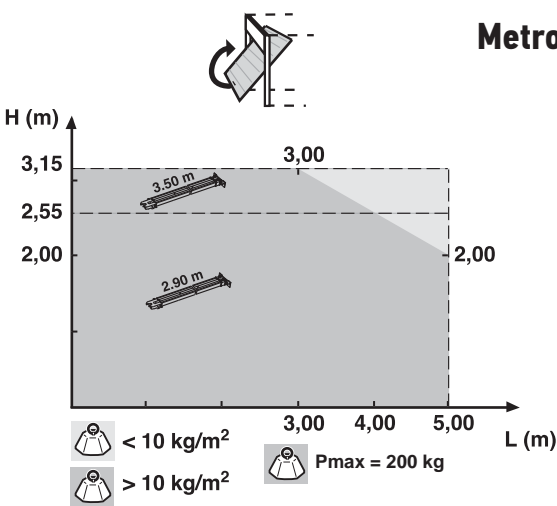
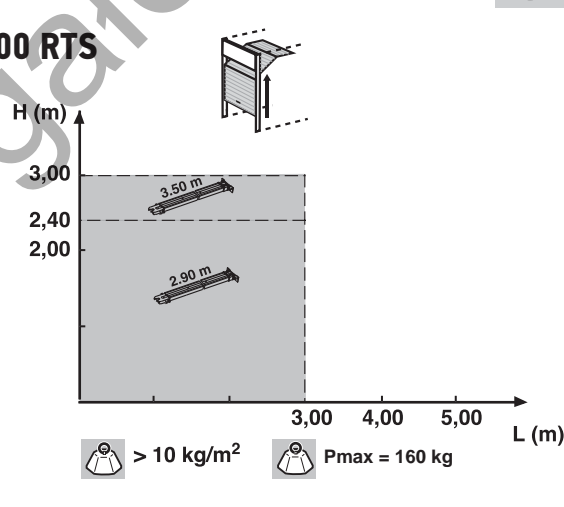
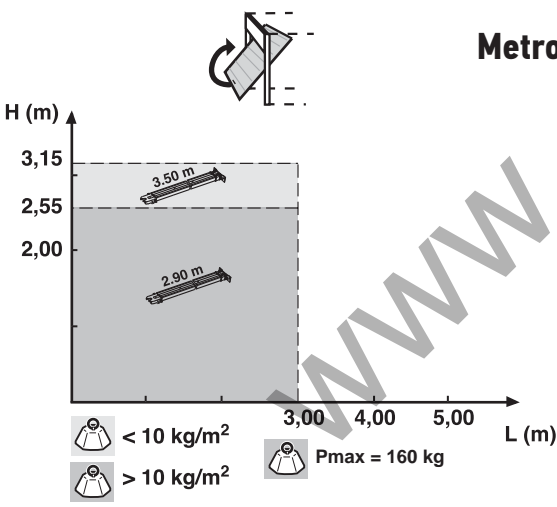
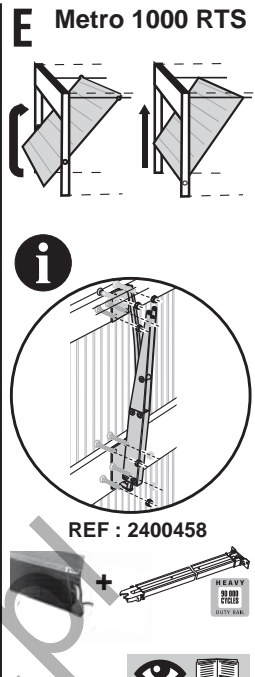
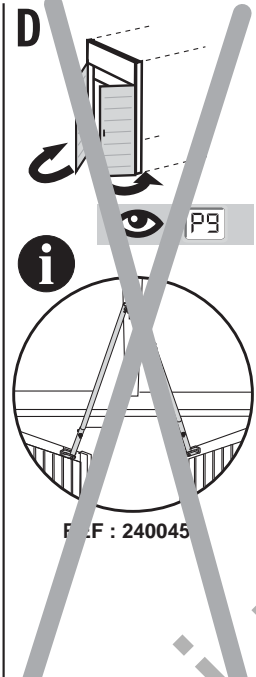
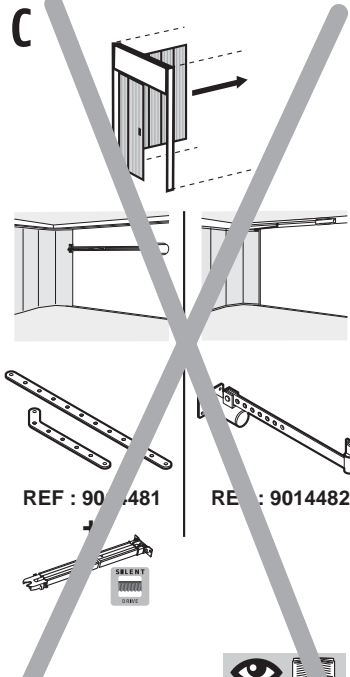
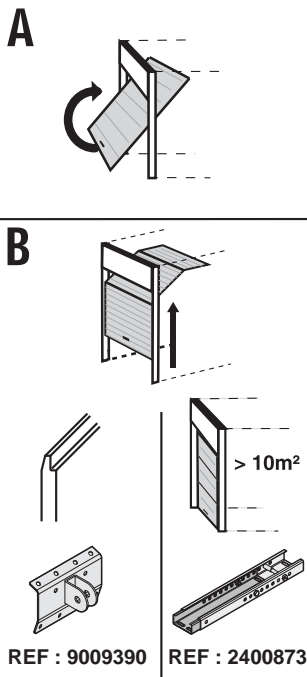

4

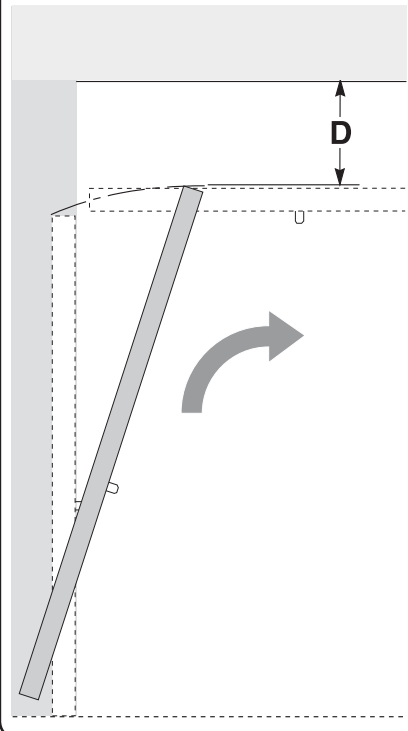

$35 < D < 140$

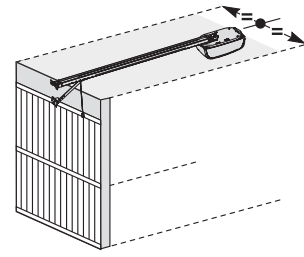
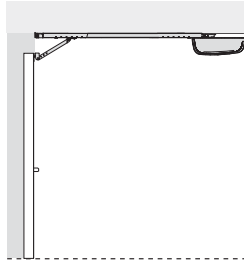

$D > 140$

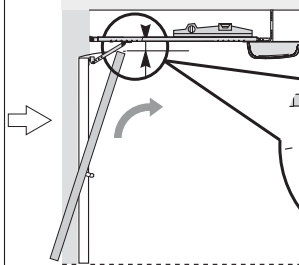

$10 < H < 140$

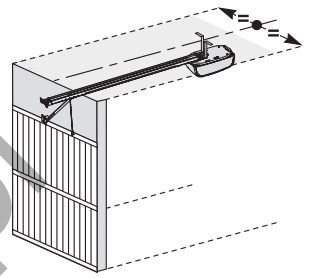

5

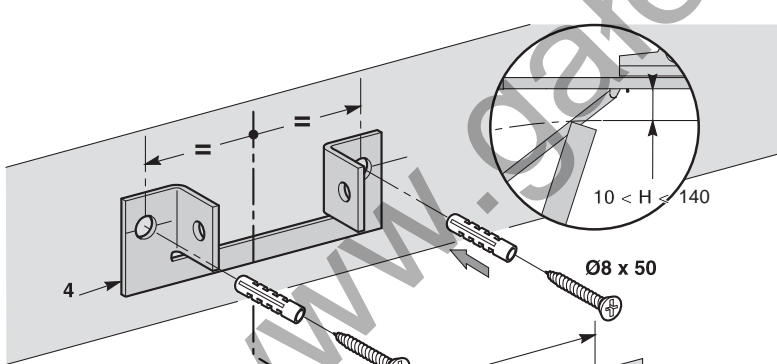

$10 < H < 140$

$\text{Ø}8 \times 50$

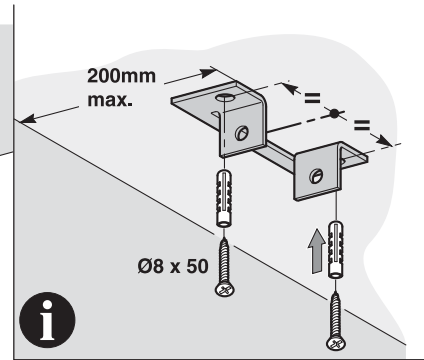

200mm
max.

$\text{Ø}8 \times 50$

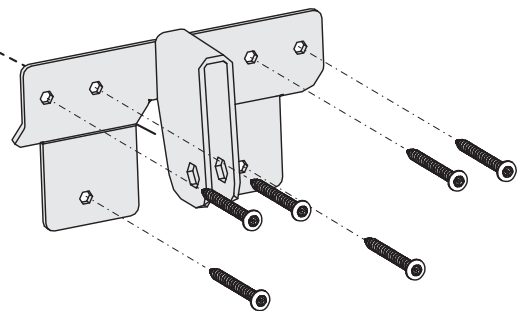
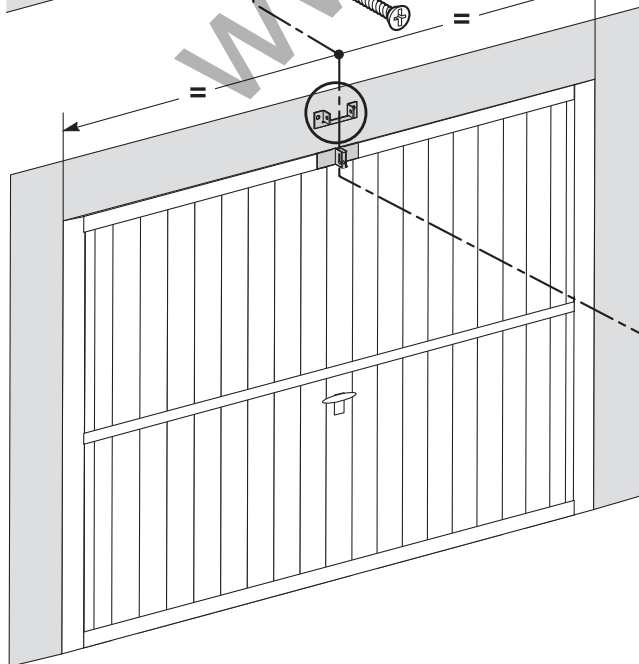

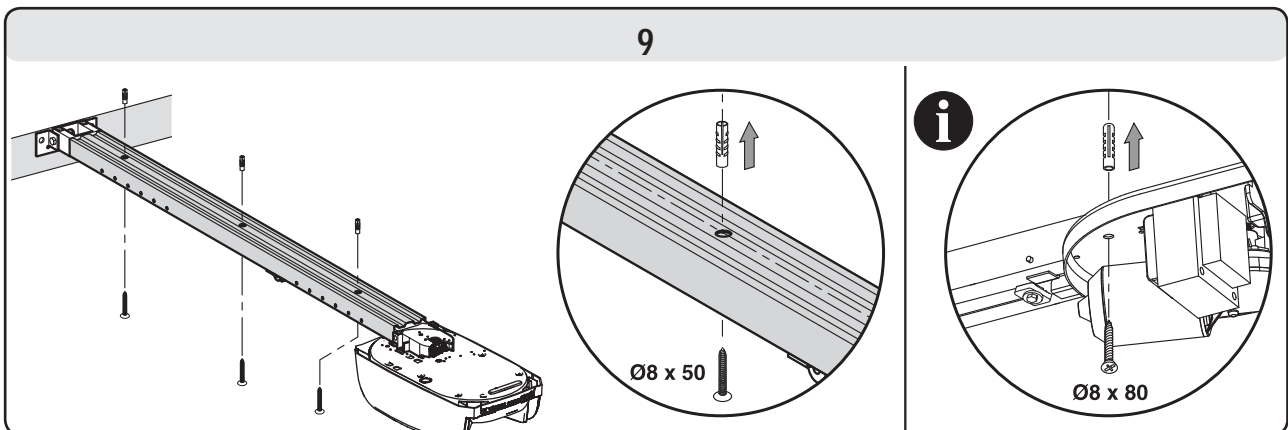
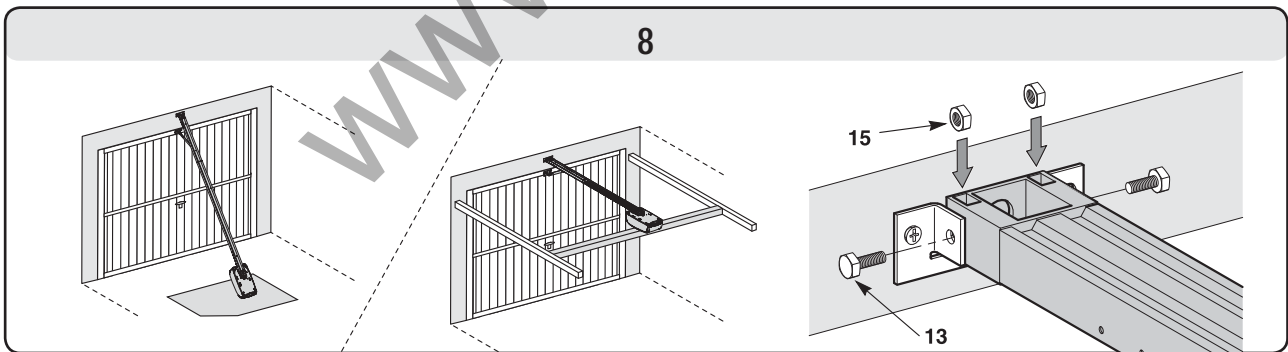
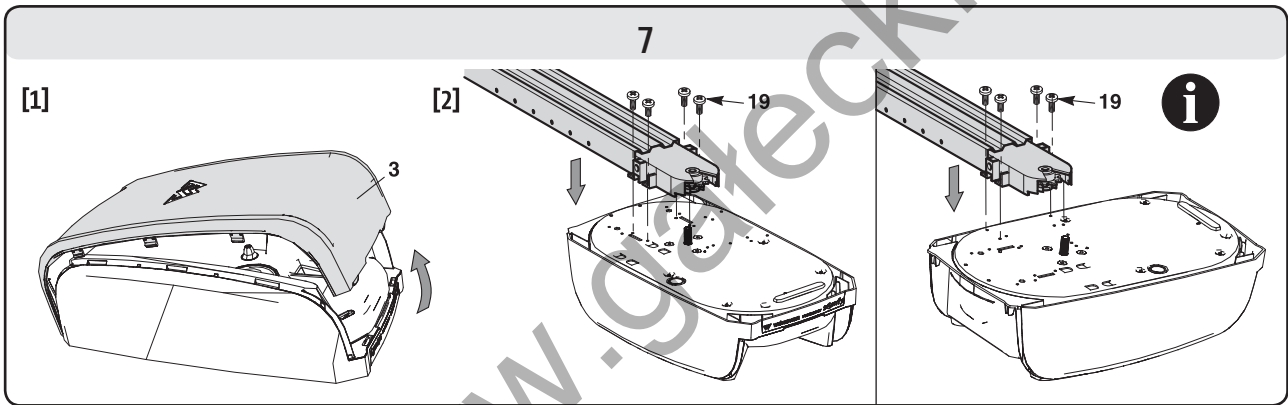
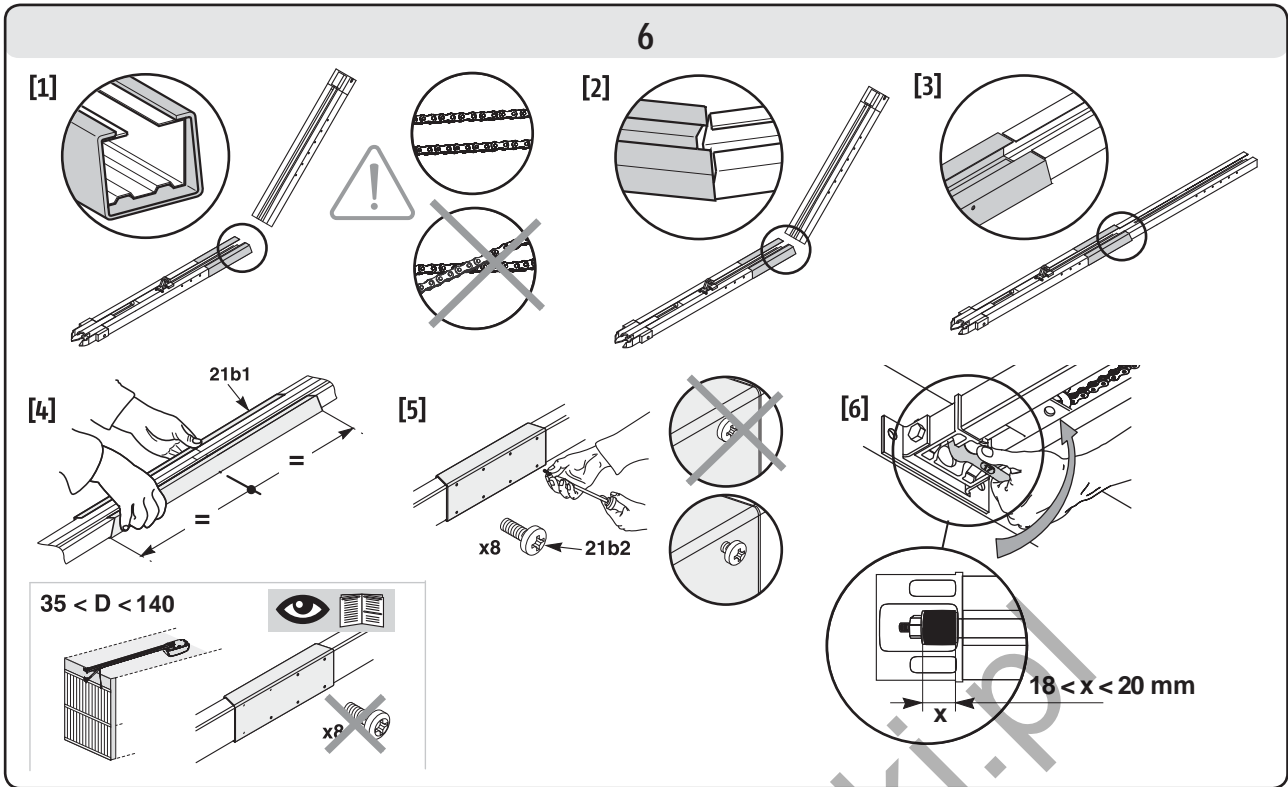

a

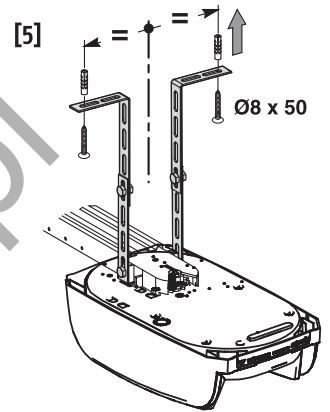
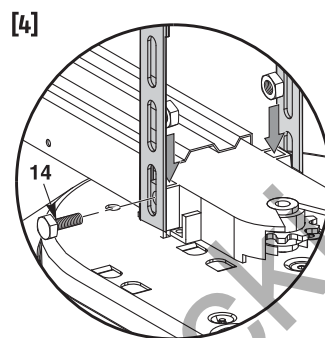
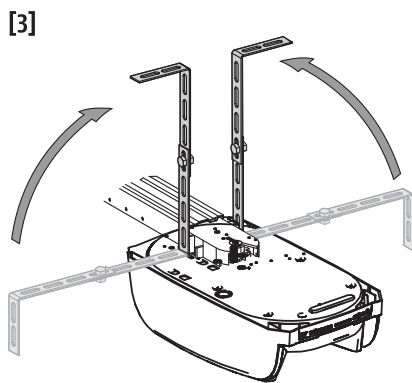
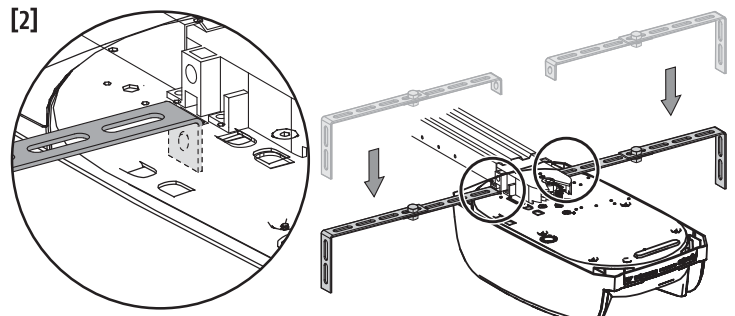
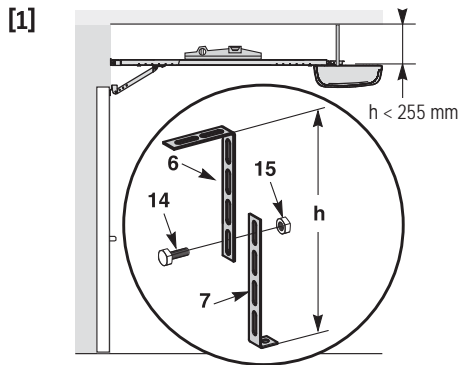

b

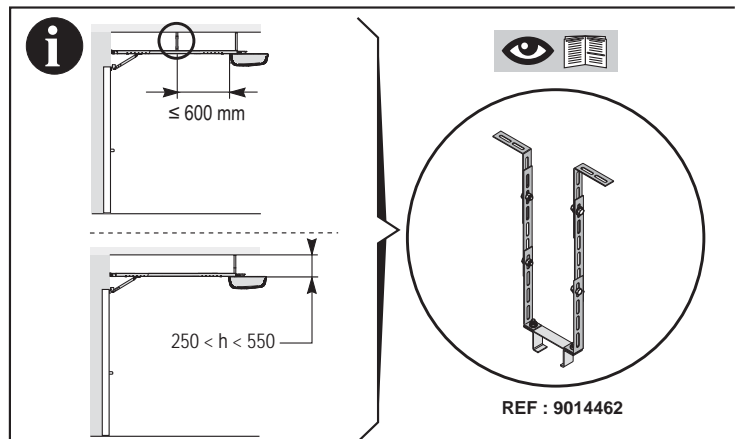
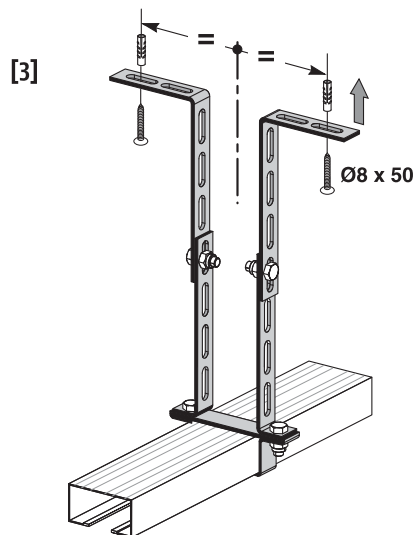
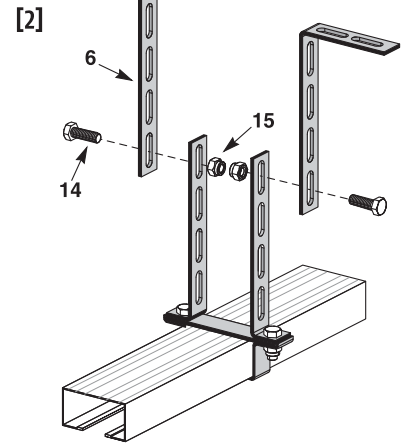
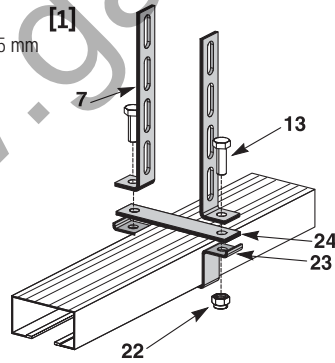
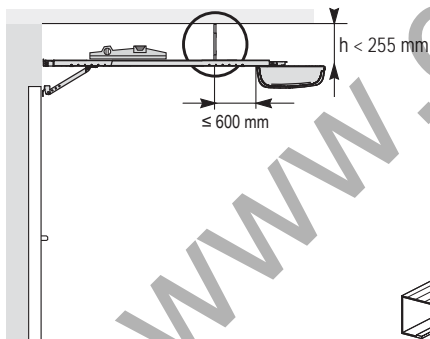

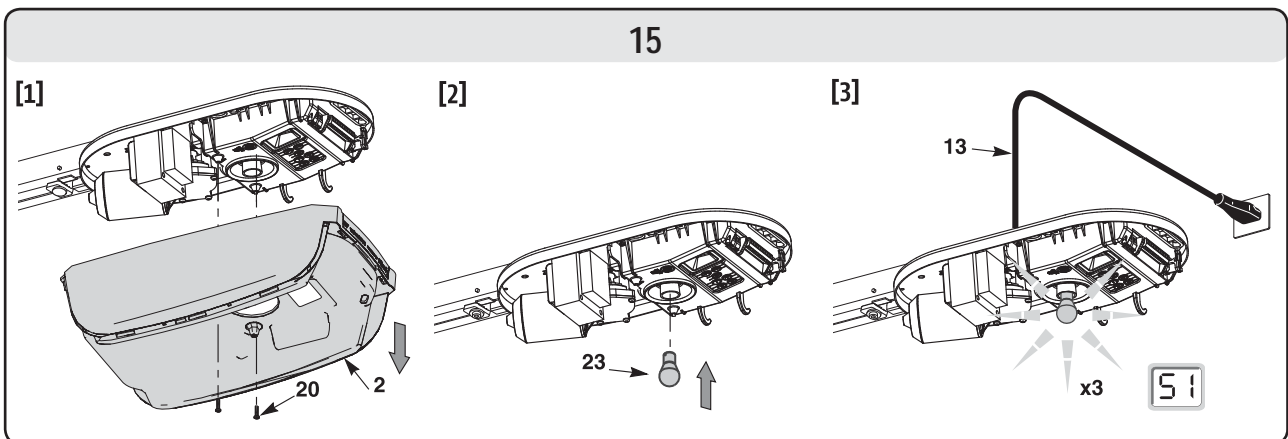
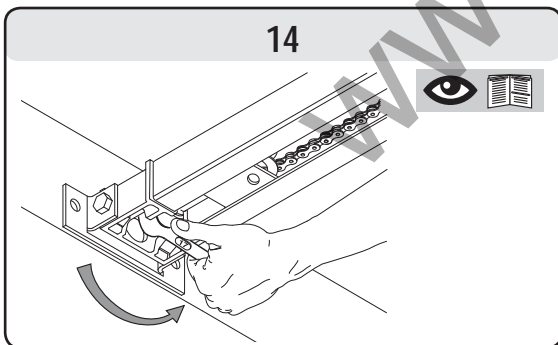
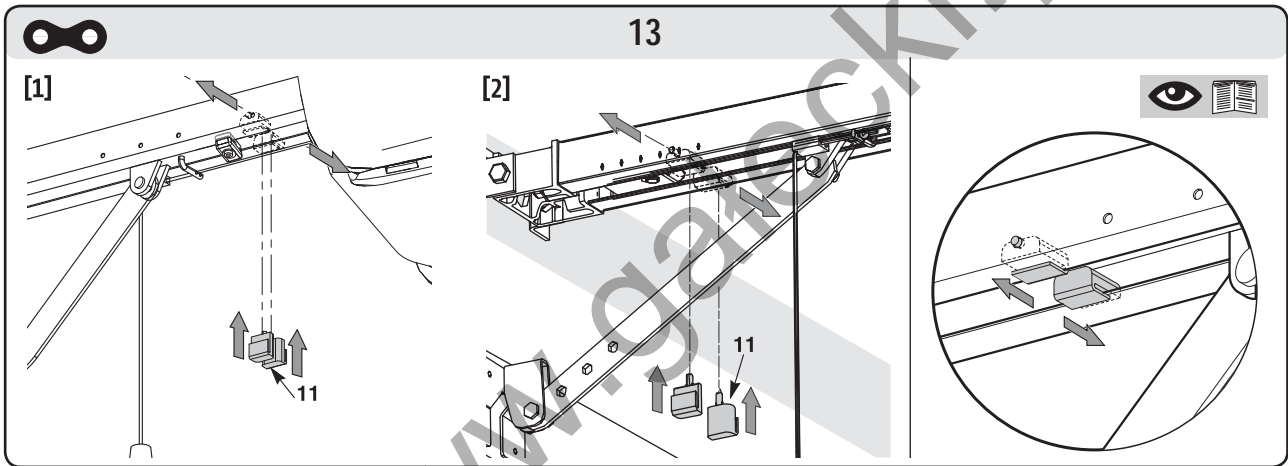
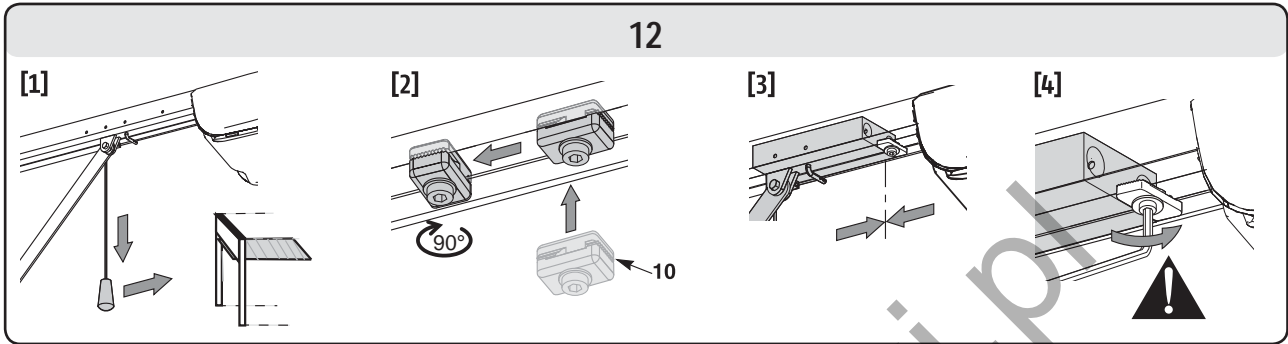
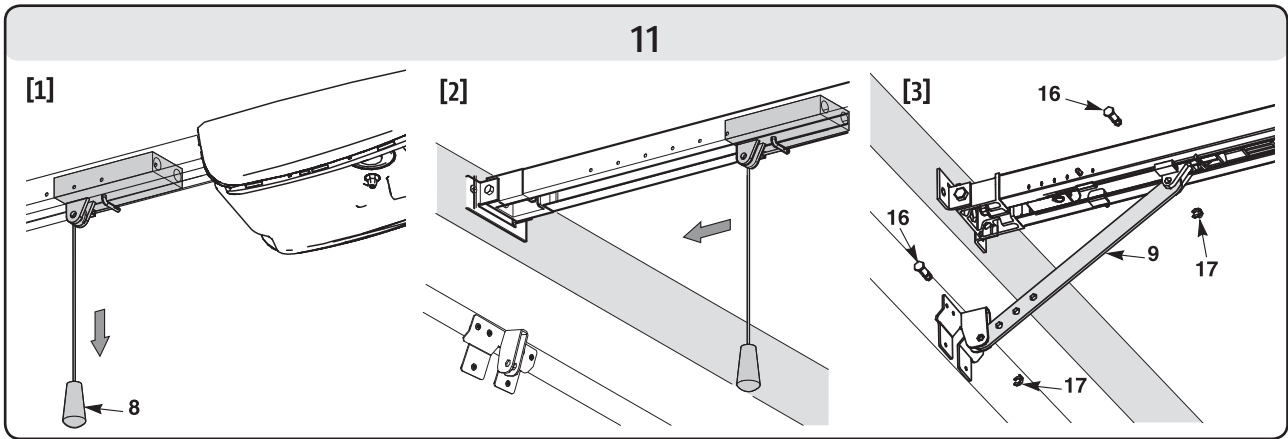

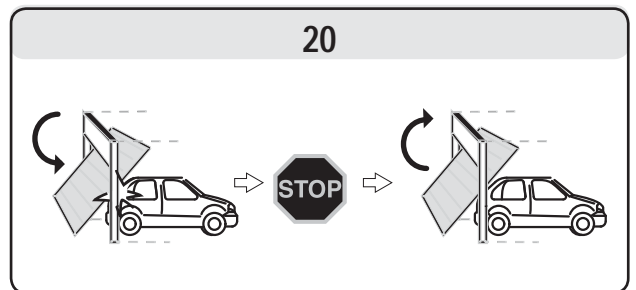
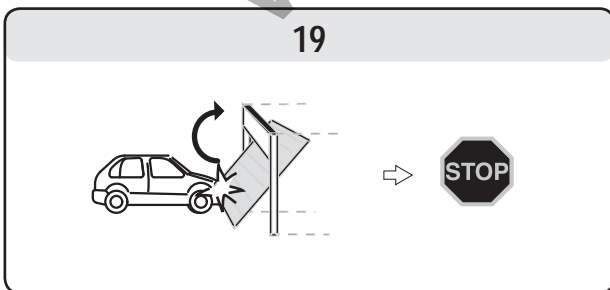
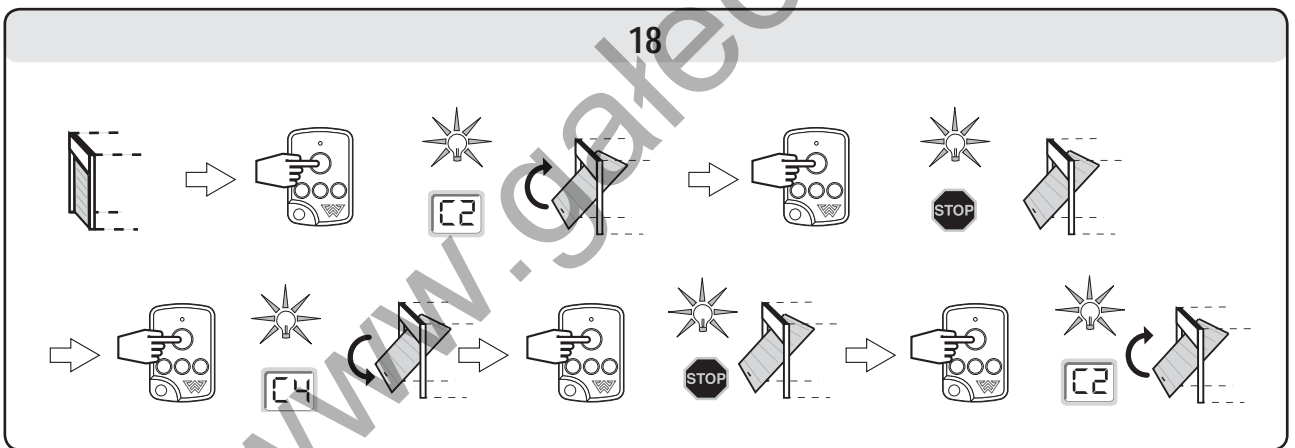
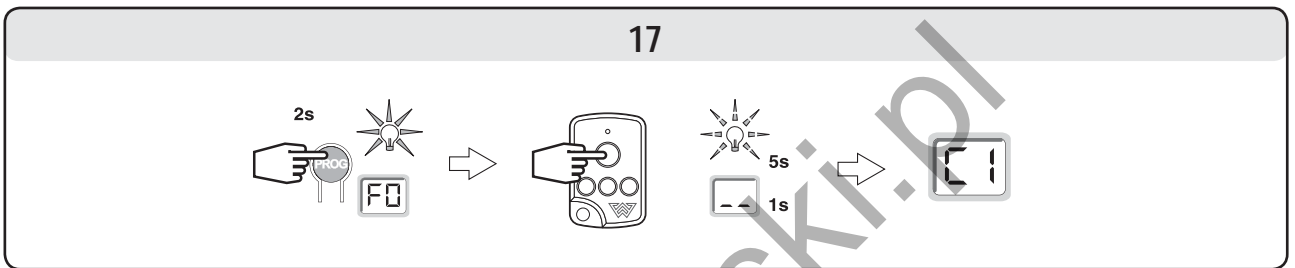
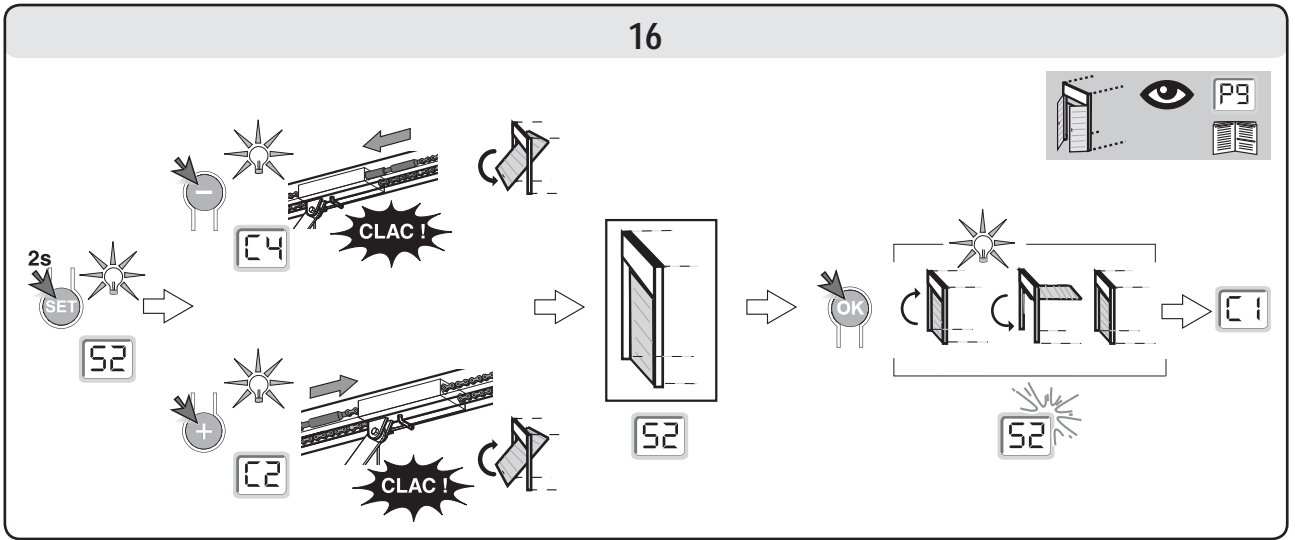

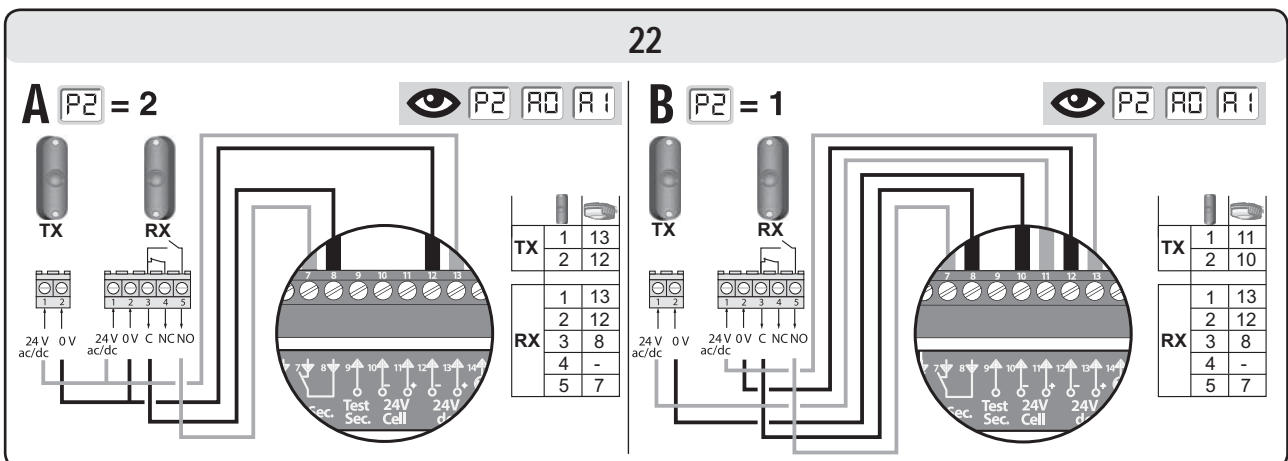
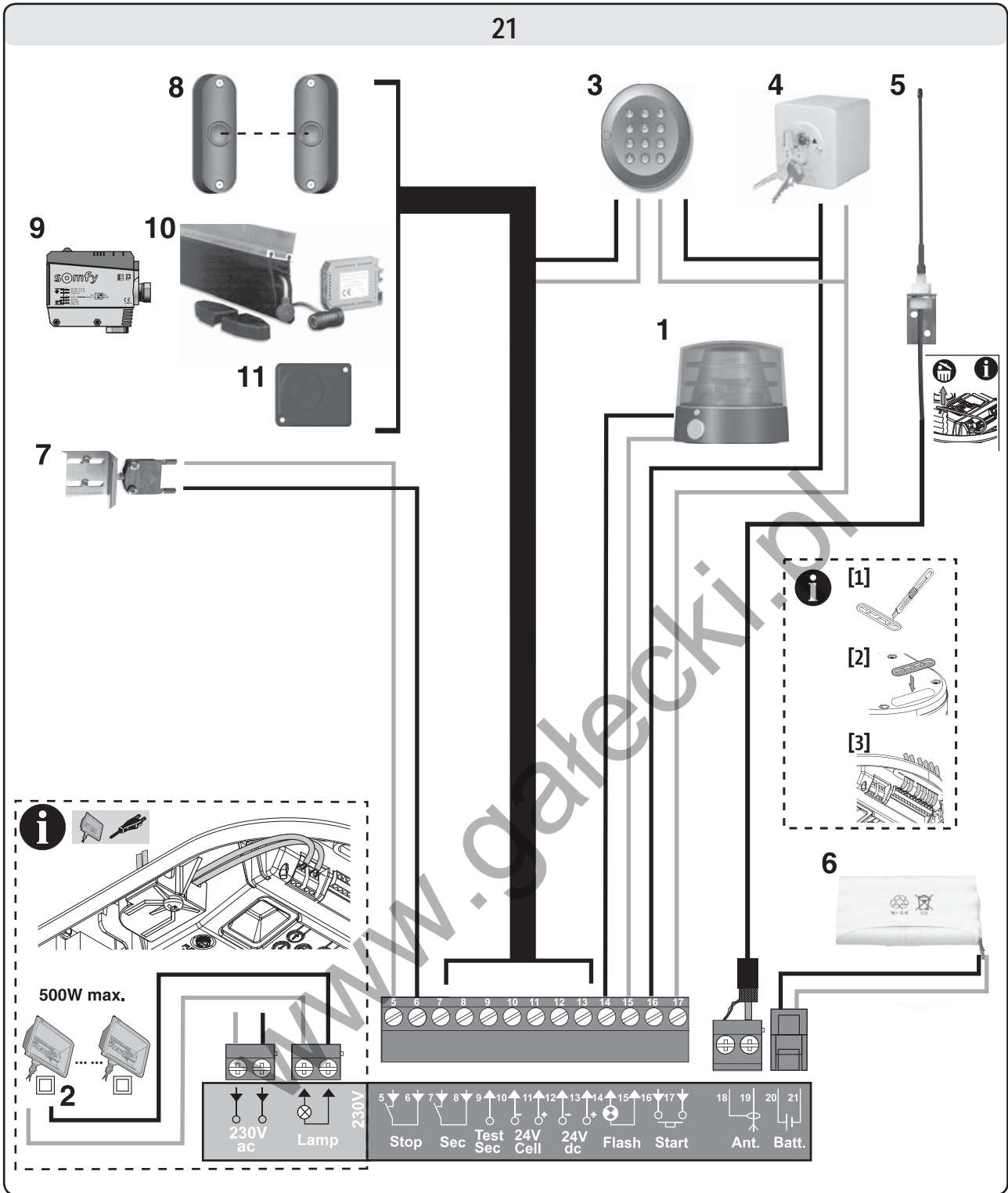

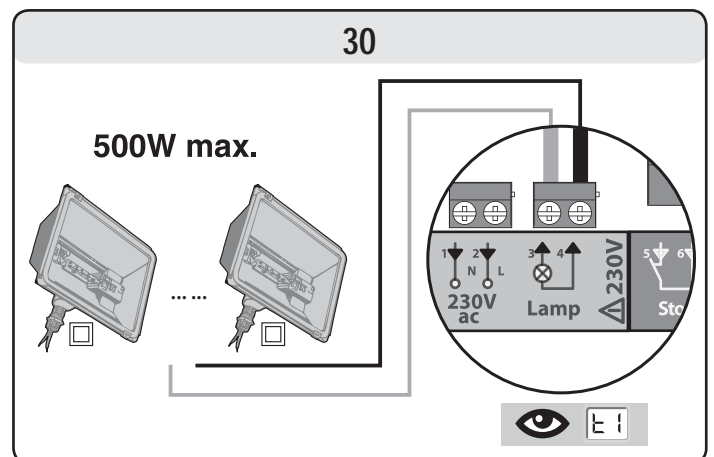
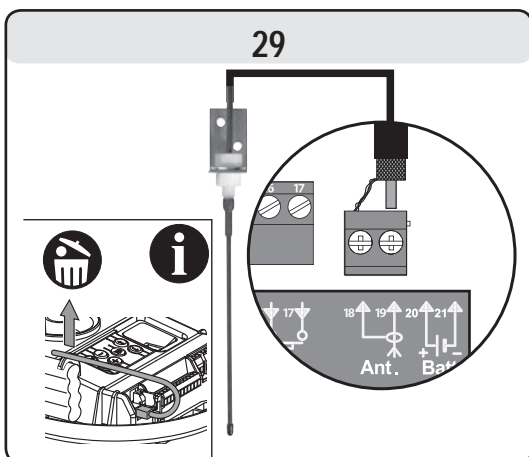
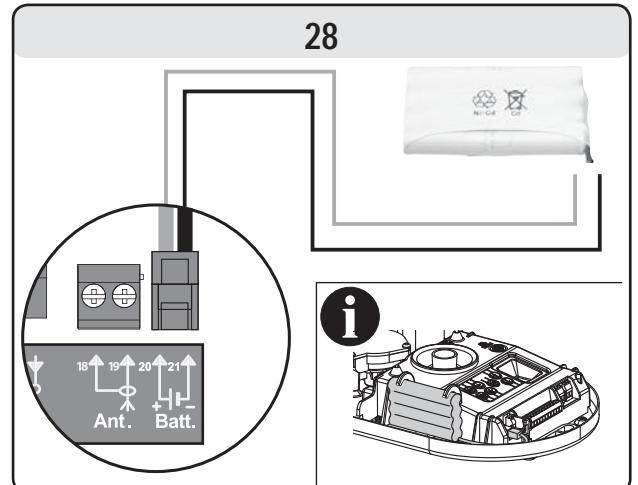
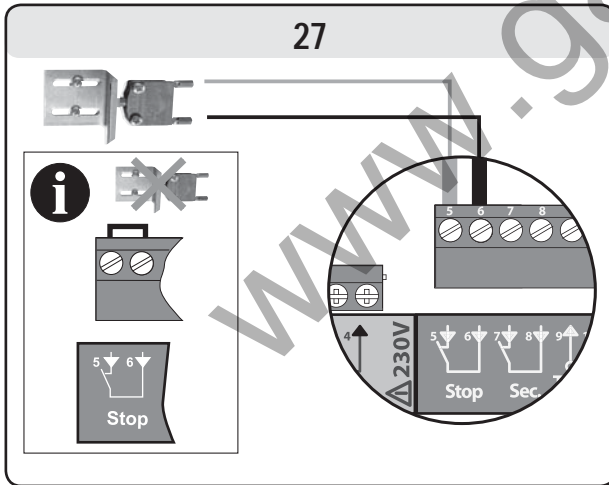
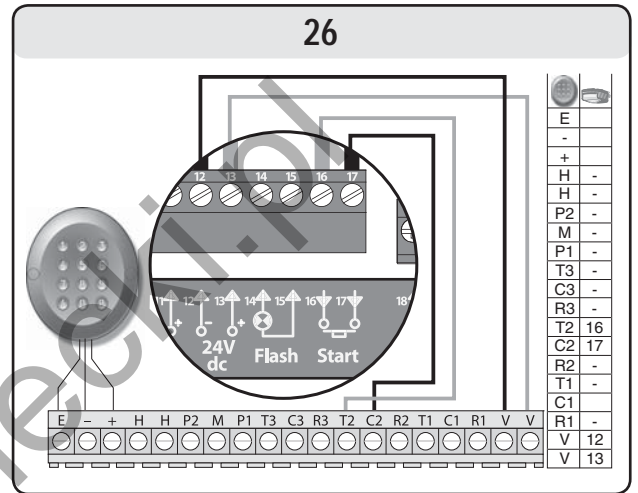
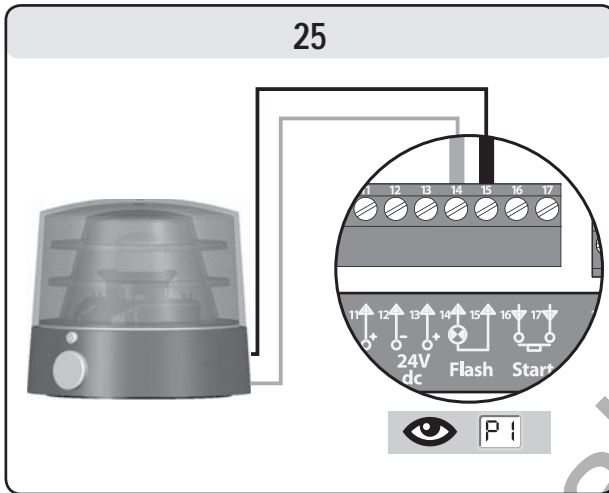
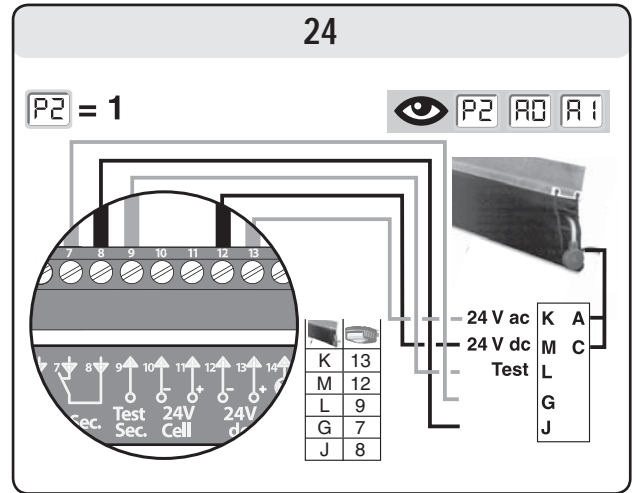
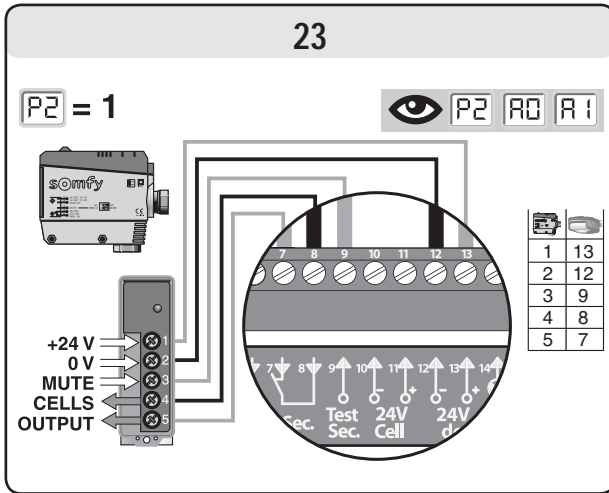

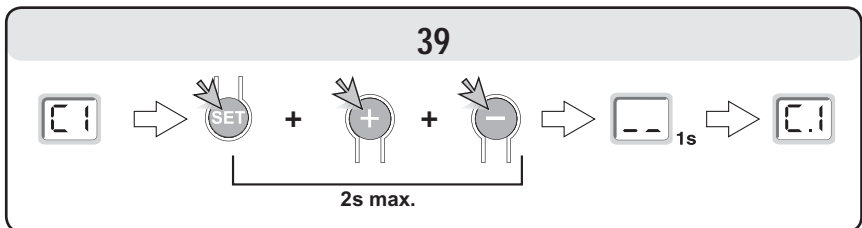
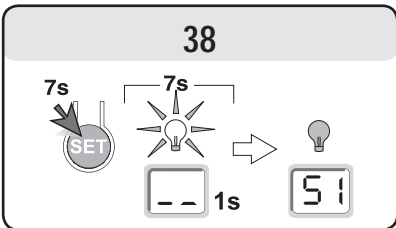
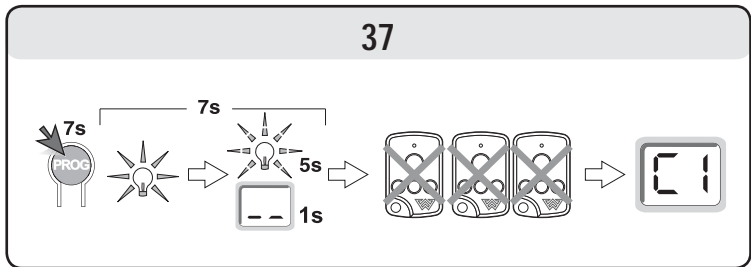
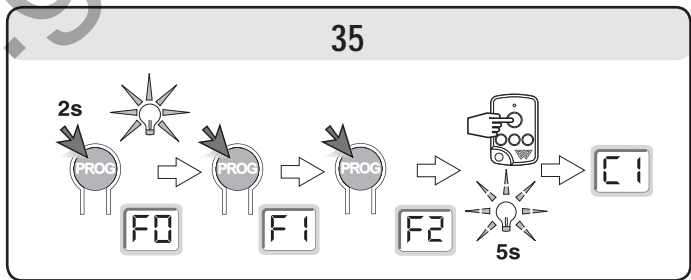
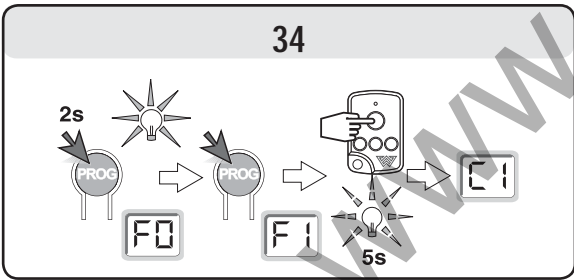
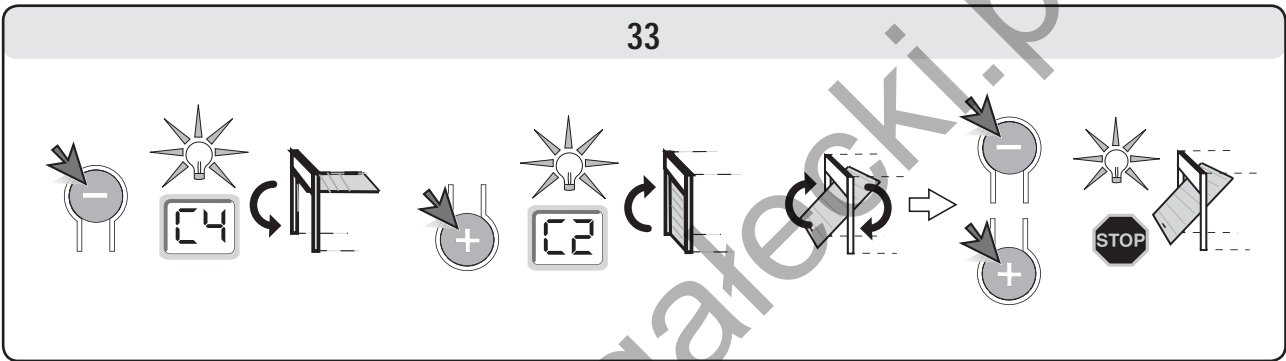
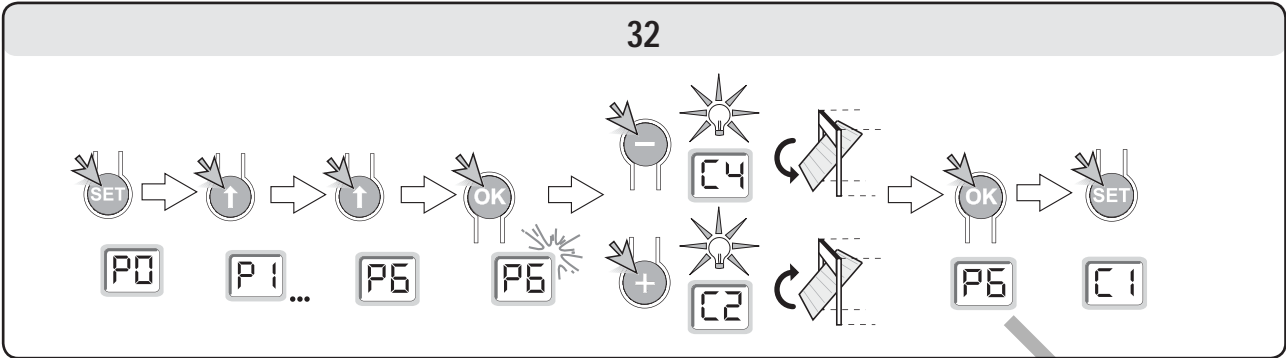
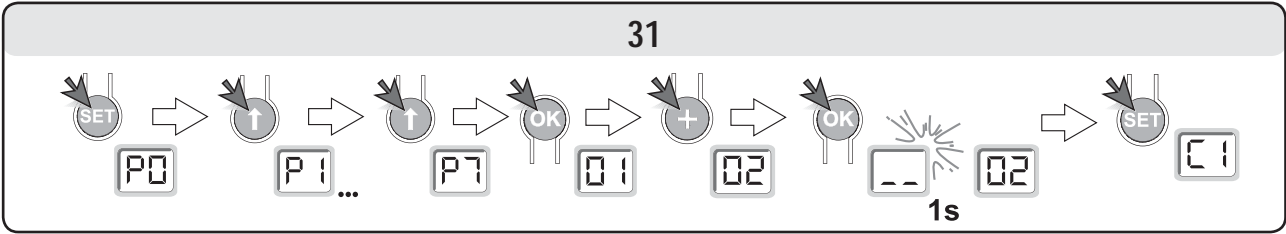

40

i

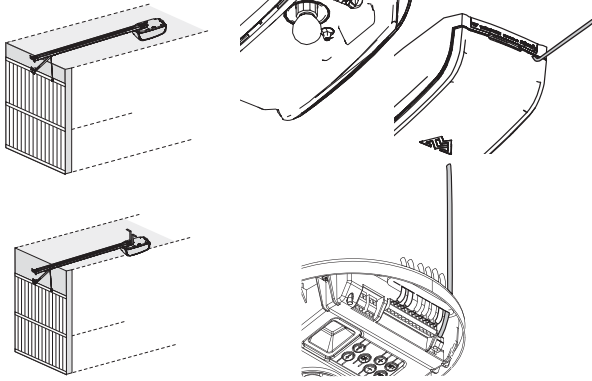

[1]

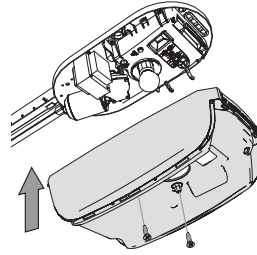

[2]

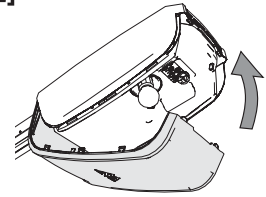

[3]



41

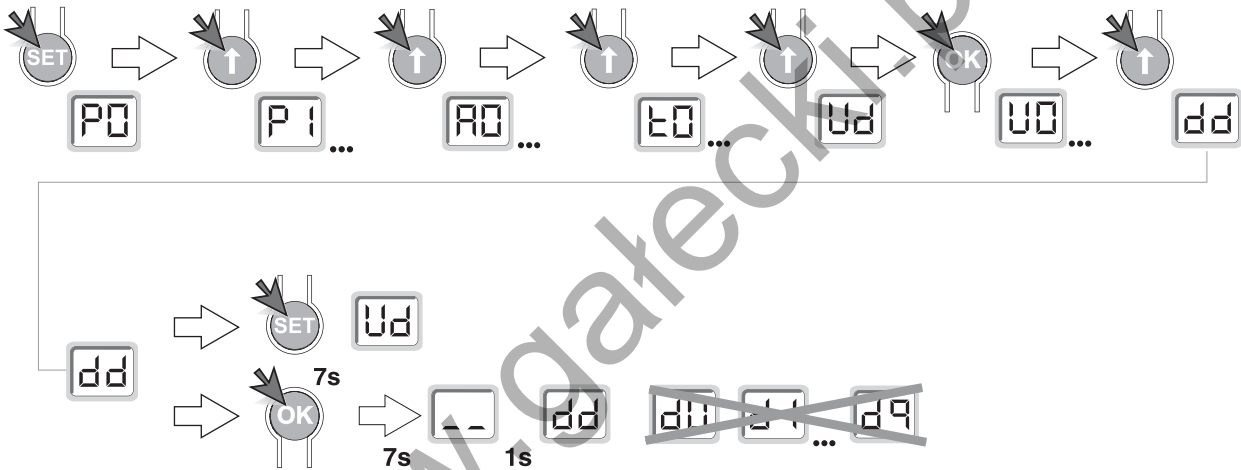

somfy[®]

Producent:

Somfy SAS
50 avenue du Nouveau Monde
F - 74300 CLUSES
FRANCAJA

www.somfy.com

WIŚNIEWSKI

Partner biznesowy:

WIŚNIEWSKI Sp. z o.o. S.K.A.
33-311 Wielogłowy 153
POLSKA
SIRET: PL734-35-13-091

Tel : +48 18 44 77 111
Fax : +48 18 44 77 110

<http://www.wisniowski.pl/METRO>

EAC
CE



PATENTS AND DESIGN PATENTS PENDING FOR SOME COUNTRIES (e.g. : US)
Somfy SAS, capital 20.000.000 Euros, RCS Amnecy 303.970.230 - 06/2016