



ATOMS™ Series Garage Door Opener

Owner's Manual

For residential use only



i **IMPORTANT:**

- Please read this manual and the enclosed safety materials carefully!
- Safety Infrared Sensor **MUST BE INSTALLED** and aligned properly.
- Periodic checks of the openers are required to ensure safe operation.
- Save this manual for future reference.
- This Equipment meets or exceeds all Federal, State and UL325 Safety requirements.
- For more information, updates and useful links, please visit our website <http://www.skylinkhome.com>



DO NOT RETURN TO THE STORE, CONTACT OUR CUSTOMER SERVICE

1-800-304-1187 M-F 9am-5pm Online Chat: www.skylinkhome.com
support@skylinkhome.com



Watch Quick Setup Videos at

www.skylinkhome.com/videos

or scan

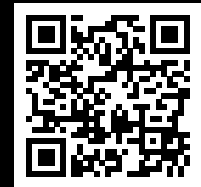

INTRODUCTION

Important Safety Information

Congratulations on your purchase of Skylink Garage Door Opener. This documentation provided with your opener has been carefully designed and organized to make the assembly, operation and continued maintenance of your product as easy and safe as possible, provided it is installed, operated, maintained and tested in strict accordance with the instructions and warning contained in this manual. Read and follow all guidelines and operating instructions before the first use of this product. Store the manual in a safe, easily accessible location.



WARNING

To prevent possible SEVERE INJURY OR DEATH:

- DO NOT install opener on an unbalanced door. Call a trained door systems technician if garage door binds, sticks or unbalanced.
- Disable all locks and remove all ropes connected to the garage door before installing the garage door opener.
- DO NOT connect the opener to any source of power until instructed to do so.
- Door Control must be installed within sight of door, at a minimum height of 5ft and away from all moving parts of the door.
- DO NOT try to remove, repair or adjust springs or anything to which door spring parts are fastened.
- Repair and adjustments must be made by a trained door system technician.
- Turn off power before removing opener cover.
- Opener must be properly grounded.
- Auto-Close Timer and Orbit Home Smartphone app cannot be used with one-piece doors. These features can only be used with sectional doors.

Safety Symbol Overview



WARNING

This type of warning symbol is used to indicate possible mechanical or electrical hazards that may cause serious injuries or death.



CAUTION

This type of warning symbol is used to indicate the possibility of damage to the garage door or opener.

CONTENTS

Introduction	1
Pre-Installation Checklist	2
Parts And Accessories	3
Hardware	5
Important Instructions	6
Assemble The Rail	7
Installation	11
Install The Header Bracket	11
Hang The Garage Door Opener	13
Install The Door Bracket	14
Install The Door Control	17
Install The Safety Beam Sensor.....	19
Programming	22
Operation	25
Open / Close Garage Door Manually	26
Remote And Keypad	27
Deluxe Wall Console	30
Erase The Memory	31
Maintenance	31
Wi-Fi Connectivity	33
Troubleshooting - Error Code	34
Troubleshooting	35
Warranty	37

PRE-INSTALLATION CHECKLIST

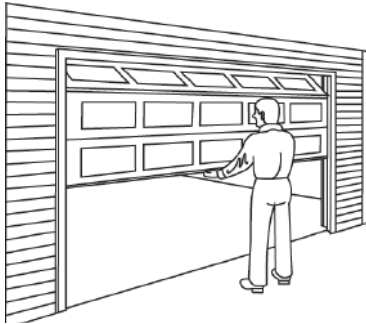

Sectional Door

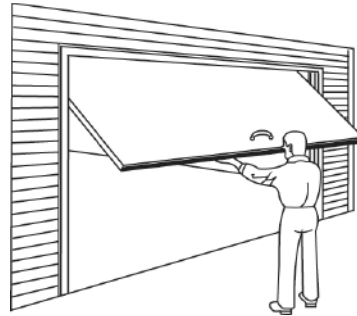

One-piece Door

Check the following items before assembling the opener:

- Identify the door type: sectional door or one-piece jamb door.
- Ensure your garage door is balanced and is not sticking or binding.
- Here is how we check the door balance:
 - From outside the garage, slowly open the door all the way and close it all the way- DOOR SHOULD NOT BIND OR RUB.
 - Raise the door halfway up – DOOR SHOULD STAY IN PLACE, SUPPORTED ENTIRELY BY ITS SPRING.

IMPORTANT

- **If the garage door fails either of these tests, have a qualified garage door professional adjust or repair the door.**
- If the garage door is lightweight (made with frame and skin, not solid), it must be braced or reinforced before installing the opener (including the door frame). Check with a qualified service professional for a door reinforcement kit.
- If you do not have an access door in addition to the garage door, you should install an emergency key release kit.
- If your door is more than 7' (2.1 m) high, you will need a rail extension kit (sold separately).
- With the garage door closed, check alignment of door and garage floor. The gap, if any, should be no more than 1/4" (6 mm). If the gap is larger than this, repair floor or door before installing opener.

PARTS AND ACCESSORIES

Save the carton and packing material until the installation and adjustment is complete. Instructions for the accessories will be attached to the accessory and are not included in this manual. The images throughout this manual are for reference only and your product may look different.

Parts

- J1.** Rail Sections
- J2.** Idler Pulley
- J3.** Trolley Assembly
- J4.** Sprocket
- J5.** Rail Brackets
- J6.** Sprocket Cover
- J7.** Door/Head Bracket
- J8.** Door/Head Bracket
- J9.** Hanging Brackets
- J10.** Straight Arm
- J11.** Curved Arm

Accessories

- J12.** Door Control*
- J13.** Safety Beam Sensors Kit
- J14.** Keychain Remote*
- J15.** Keyless Entry*
- J16.** Wi-Fi Adapter*

Parts

- K1.** Chain/Belt Assembly*
- K2.** Turnbuckle Connector
- K3.** Turnbuckle
- K4.** Holding Hook

NOTE*

Note that accessories will depend on the model you purchased. If anything is missing, carefully check the packing material.

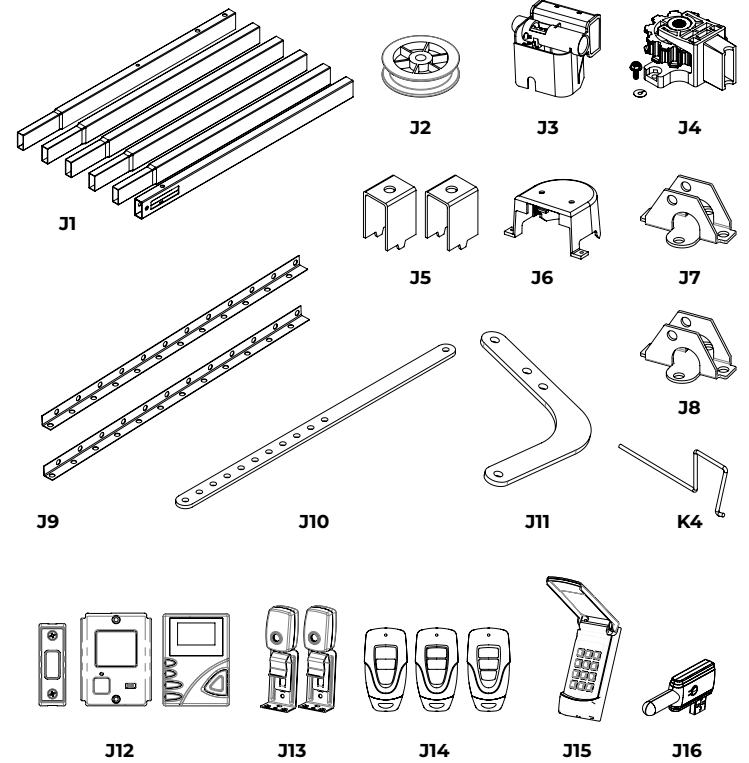

PARTS AND ACCESSORIES

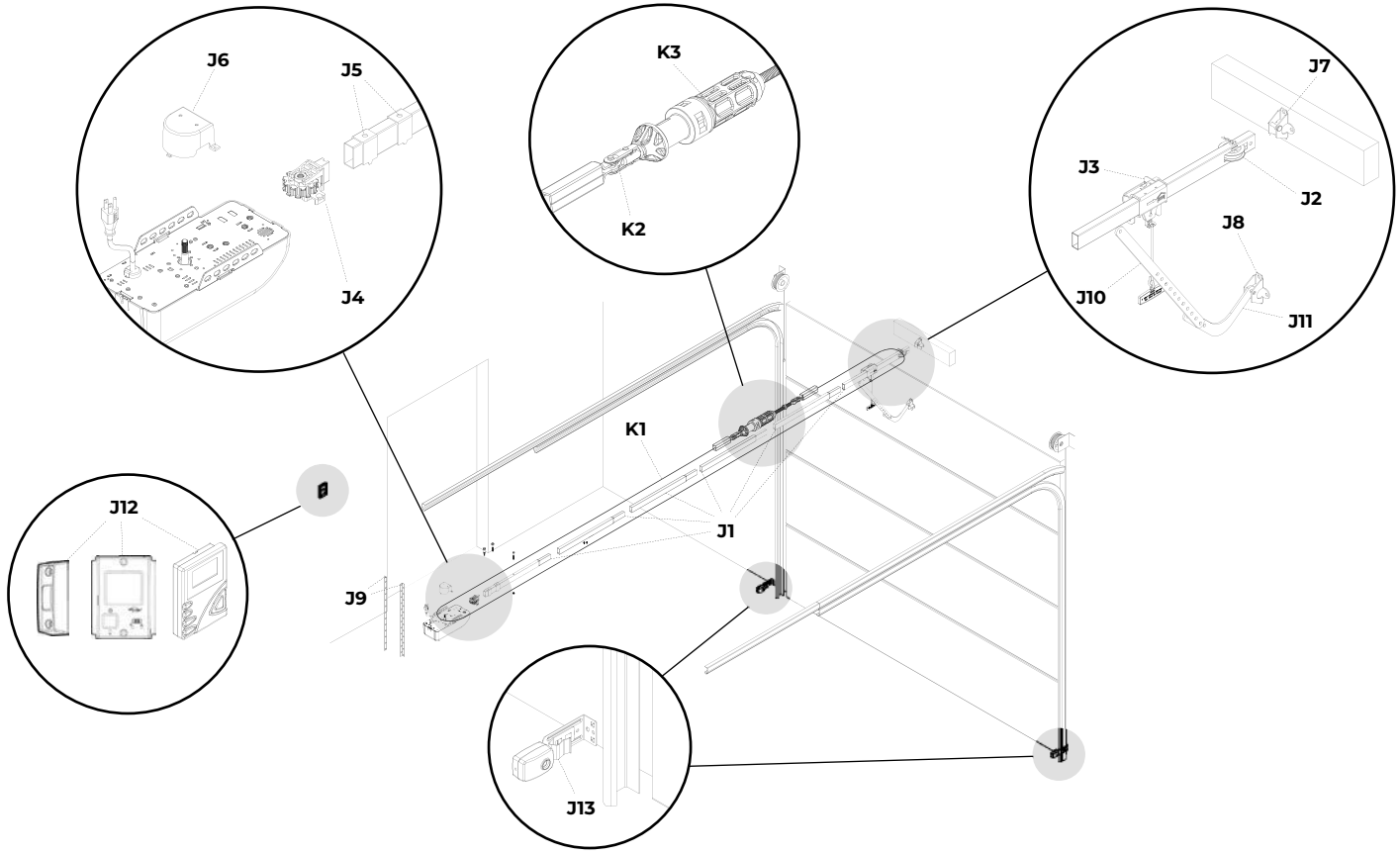

HARDWARE

Bag A

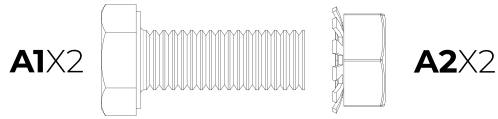

Bag B

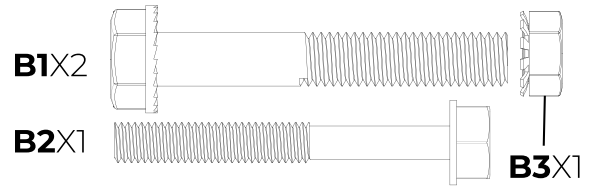

Bag C

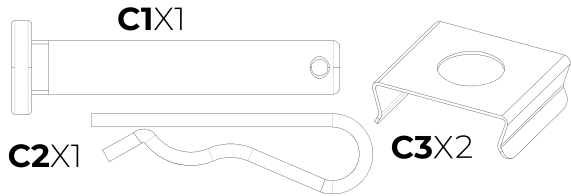

Bag D

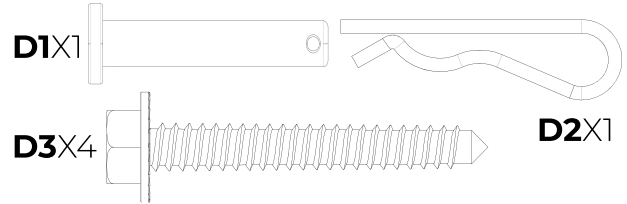

Bag E

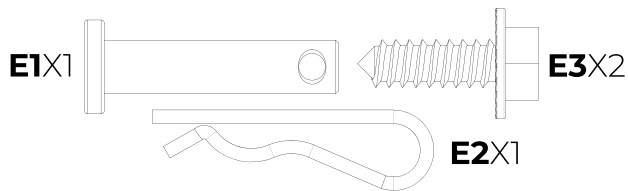

Bag F

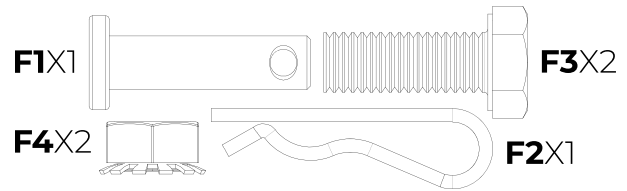

IMPORTANT INSTRUCTIONS

To reduce the risk of severe injury or death:

1. **Read and follow all installation instructions.**
2. Check with the door manufacturer to determine if additional reinforcement is required to support the door prior to installation of the garage door opener.
3. Install garage door opener only on a proper balanced garage door. An improperly balanced door could cause serious injury. Have a qualified service professional make repairs to garage door cables, spring assemblies and other hardware before installing the opener.
4. Remove all ropes and disable all locks connected to the garage door before installing opener.
5. Mount the emergency release handle 6' (1.8m) above floor.
6. Do not connect the opener to source of power until this manual instructs you to do so.
7. Locate the door control:
 - a. Within sight of the garage door.
 - b. Out of reach of children at minimum height of 5' (1.5 m).
 - c. Away from all moving parts of the door.
8. Place entrapment warning label on wall next to garage door wall control.
9. Install the Emergency Release Handle on the emergency release rope.
10. Place manual release/safety reverse test label in plain view on inside of garage door.
11. Upon completion of the installation, the door must reverse when it comes in contact with a 11/2" (3.8 cm) high object on the floor (or a 2x4 laid flat at the centre of the door) and when the infrared safety beam is blocked.

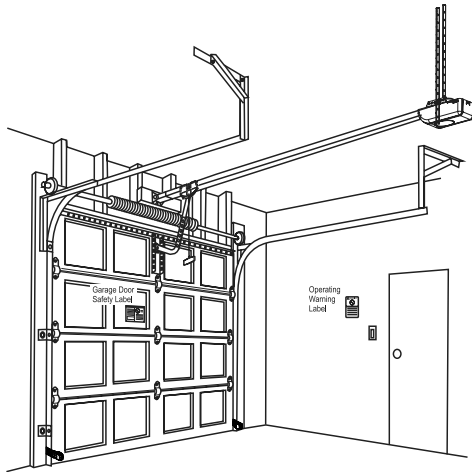

An overall view of a completed garage door opener system installed on a sectional door. The arrangement is similar for a one-piece jamb door (except for differences described later in this manual).

ASSEMBLE THE RAIL

Step 1 – Assemble the rail and insert the trolley

CAUTION

To prevent INJURY from pinching, keep hands and fingers away from the joints while assembling the rail.

To avoid installation difficulties, do not run the garage door opener until instructed to do so.

1. Align the rail sections [J1] on a flat surface as shown and slide the tapered ends into the larger ones. Pay attention to the 2 unique rail sections, the “Door End” and “Motor End” sections as shown.
2. Slide the Trolley Assembly [J3] from the “Motor End” as shown. Note the [] icon should point towards “Door End”.
3. Secure 2 clip washers [C3] into the “Door End” window as shown, line up the holes on the clip washers and on the rail.
4. Place the idler pulley [J2] into the window as shown.
5. Insert the idler bolt [C1] from the top through the rail and pulley, secure with the hitch pin [C2].

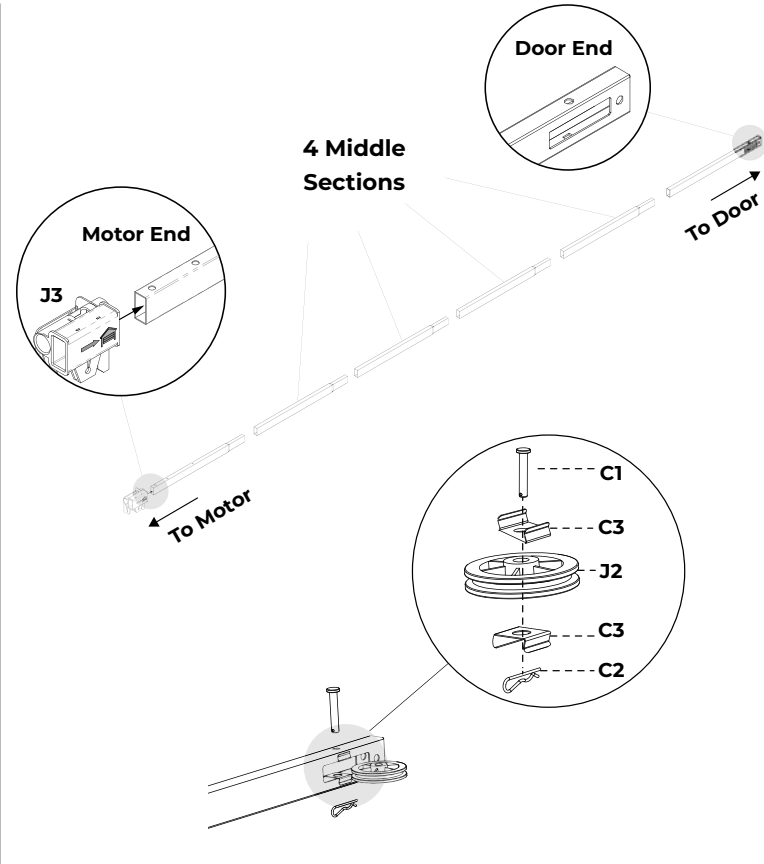

ASSEMBLE THE RAIL

Step 2 – Fasten the rail to the motor unit

CAUTION

To avoid **SERIOUS** damage to garage door opener, use **ONLY** those bolts/fasteners provided in the designated bags.

To avoid installation difficulties, do not run the garage door opener until instructed to do so.

1. Leave the motor unit in the carton tray, and rest the “Door End” of the rail on top of the other carton tray.
2. Insert the sprocket assembly [J4] to the “Motor End” rail.
3. Insert the sprocket assembly over the motor shaft as shown.
4. Place 2 U-brackets [J5] over the rail. Align the 2 tabs to the 2 slots on the motor head and secure with 2 bolts [B1].
5. Secure the 2 screws on the sprocket assembly to the motor unit.
6. Insert bolt [B2] into the stop bolt hole on the motor end of the rail as shown. Tighten with lock nut [B3].

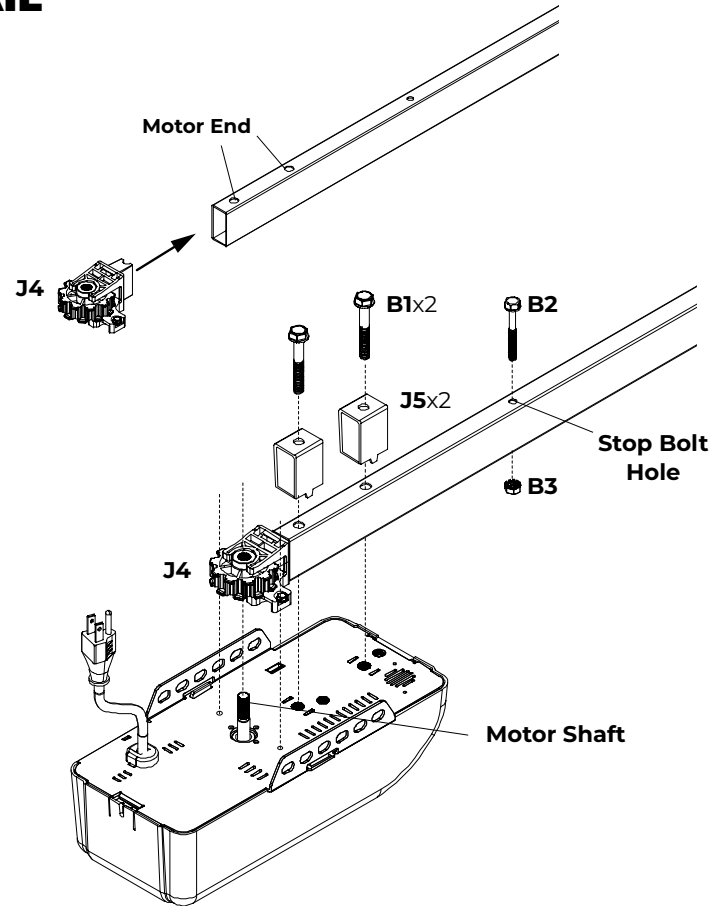

ASSEMBLE THE RAIL

Step 3 – Install the chain / belt

CAUTION

To avoid possible **SERIOUS INJURY** to finger from moving garage door opener:

- ALWAYS keep hand clear of sprocket, chain / belt or any moving parts while operating opener.
- Securely attach sprocket cover **BEFORE** operating.

1. Lay the chain / belt beside the rail as shown.
2. Grasp the turnbuckle connector **[K2]** at the end of the chain / belt assembly, pass it through the window.
3. Position the trolley assembly **[J3]** near the door end. Pull the chain assembly (cable end) / belt around the idler pulley **[J2]** and feed through the trolley. Place the turnbuckle connector 2ft from idler pulley.
Note: The cable on the chain assembly, or the ribbed side on the belt assembly must contact the pulley.
4. Grasp the turnbuckle **[K3]** and dispense the remainder of the chain assembly / belt along the rail toward the motor unit around the sprocket assembly and continuing to the turnbuckle connector. The sprocket assembly **[J4]** teeth must engage the chain / belt.
5. Hook the turnbuckle into the turnbuckle connector.

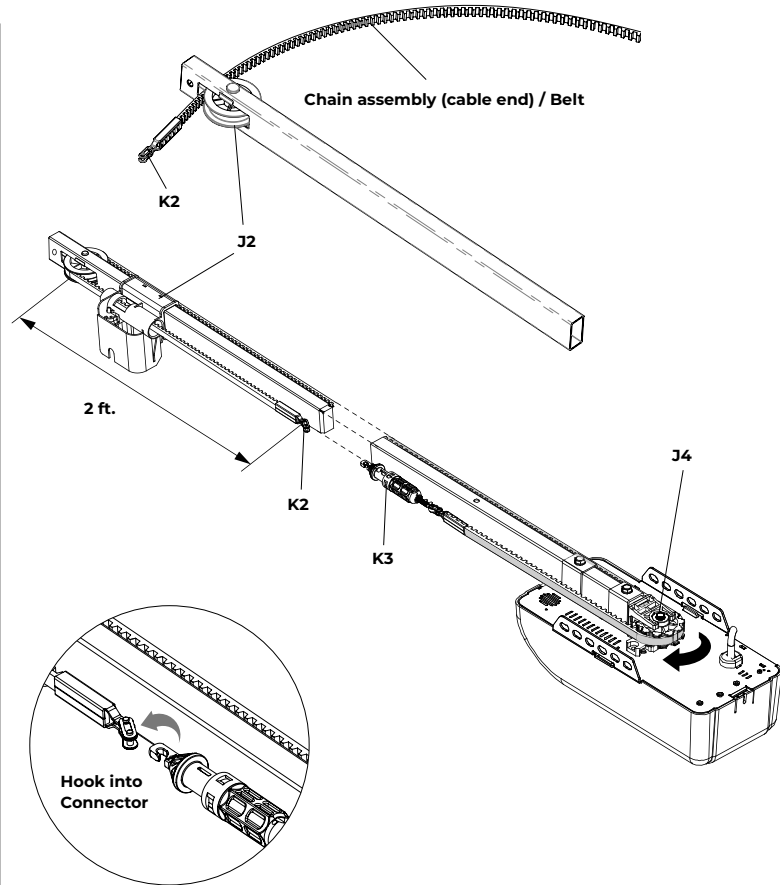

ASSEMBLE THE RAIL

Step 4 – Tighten the chain / belt

NOTE

During future maintenance, ALWAYS pull the emergency release handle to disconnect the trolley before adjusting the chain.

1. To avoid twisting the chain-cable / belt assembly, place the holding hook [K4] on the rail and insert the long end through the turnbuckle connector as shown.
2. Hold the threaded end of the turnbuckle with one hand while turning the turnbuckle with the other to tighten the chain / belt until the chain / belt is approximately 5/16" (8mm) above the base of the rail at its midpoint.
3. Remove the "U" pin from the turnbuckle.
4. Attach sprocket cover [J6] by clipping it onto the motor unit.

You have now finished assembling your garage door opener. Please proceed to the installation section.

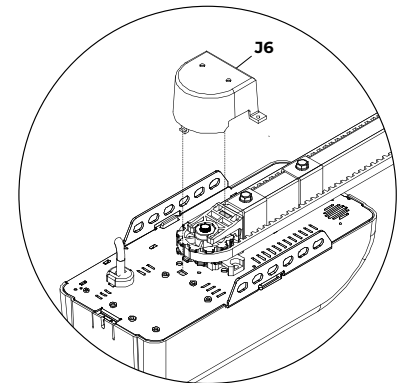
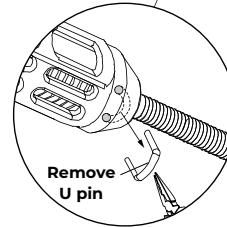
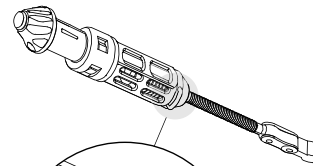
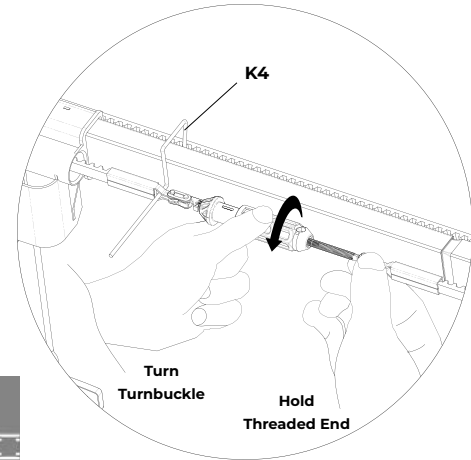

INSTALLATION

Step 1 – Install the header bracket

! WARNING

- Door springs are under high tension. If spring or shaft is in the way, measure above the spring or shaft on the garage door centreline and mark as location for header bracket. DO NOT ATTEMPT TO MOVE, ADJUST, OR REMOVE DOOR SPRING!
- Header Bracket must be fastened to garage framing. DO NOT fasten to drywall, particle board, plaster, or other such materials.
- Concrete anchors MUST be used if mounting header bracket or 2x4 into masonry.
- ALWAYS call a trained door systems technician if garage door binds, sticks, or is out of balance. An unbalanced garage door might NOT reverse when required.

1. Close the door and mark the inside vertical centreline of the garage door.
2. Open the door slowly and find the highest point of travel where the door extends above the door tracks. For sectional doors this is typically where the top door roller exits the curved portion of the track onto the horizontal section as the door is raised.
3. Place a mark on the header wall at the highest point of door travel, preferably at the center of the door.
4. For sectional door, install the header bracket [J7] 2" (5cm) above the highest point of door travel.
5. For one-piece door, install the header bracket [J7] 8" (20cm) above the highest point of door travel.
6. Drill 5/32" holes in the header wall and secure bracket with lag screws [D3].

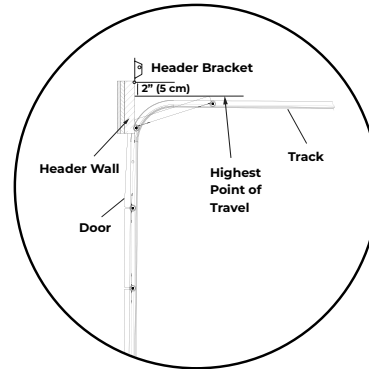
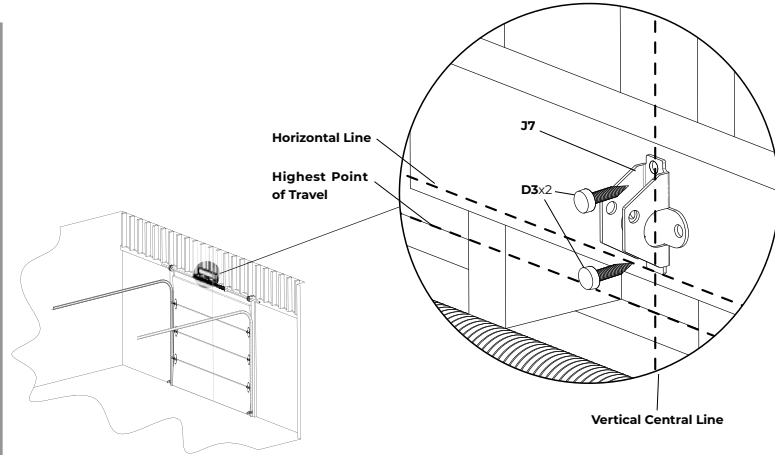

Sectional Door

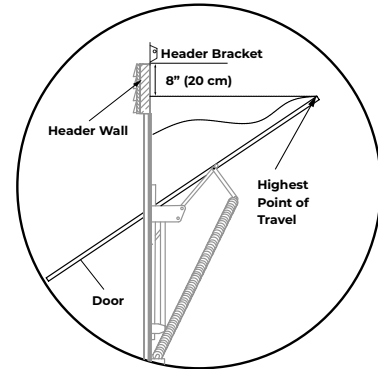

One-Piece Door

INSTALLATION

Step 2 – Attach the rail to the header bracket

1. Position the opener on the floor below the header bracket. If the door spring is in the way, have someone to hold the opener to allow the rail to clear the spring.
2. Align holes in rail with holes in header bracket.
3. Slide clevis pin **[D1]** through holes in rail and bracket and secure with hitch pin **[D2]**.

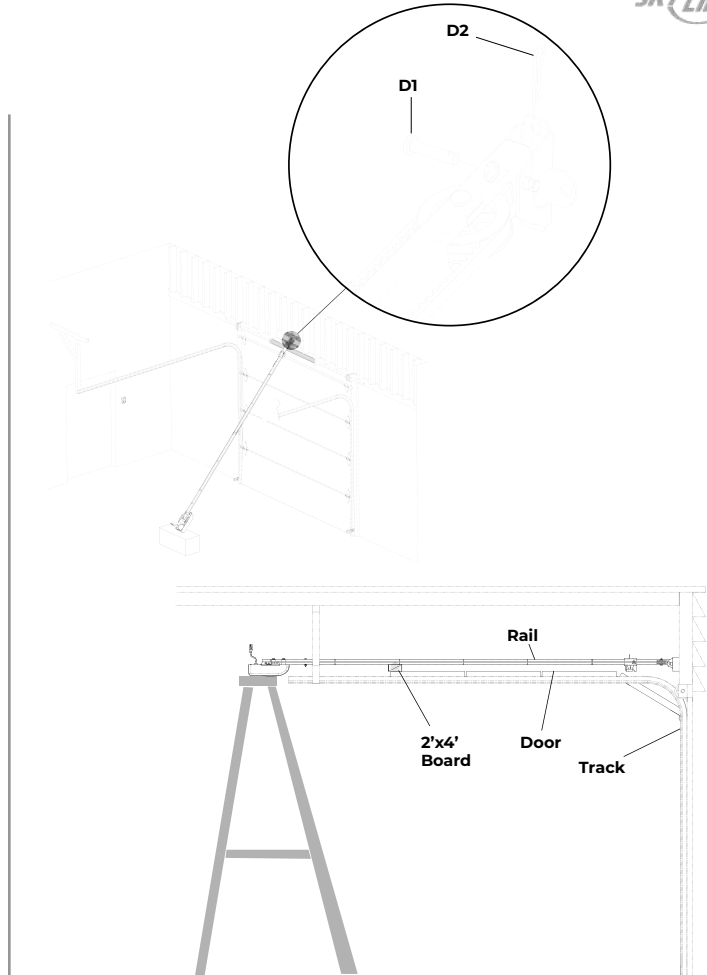

Step 3 – Position the garage door opener

1. Lift the garage door opener and rest it on a ladder. Ensure the ladder is high enough to allow the door open fully.
2. Fully open the door and place a 2x4 board between door and rail to protect door.

INSTALLATION

Step 4 – Hang the garage door opener to ceiling

1. On unfinished ceilings with open structural supports or exposed joist, drill 5/32" pilot holes and secure included hanging brackets [J9] to joist using lag screws [D3].
2. For finished ceilings without exposed joist, attach perforated angle (not provided) to joists using lag screws [D3] and secure hanging brackets to the perforated angle with bolts and nuts (not provided).
3. Raise garage door opener unit so that there is sufficient clearance between door and rail. Measure the distance from each side of the garage door opener to the hanging bracket.
4. Cut both hanging brackets to required lengths.
5. Attach the garage door opener to hanging brackets using bolts [A1] and nuts [A2].
6. Ensure garage door opener is centered with the door.
7. Remove the 2 x 4 board and/or other protective material.
8. Close the garage door manually.

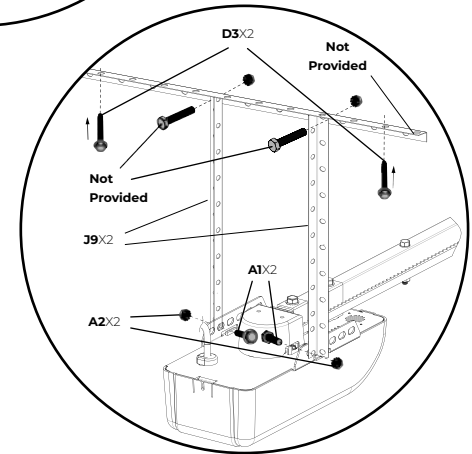
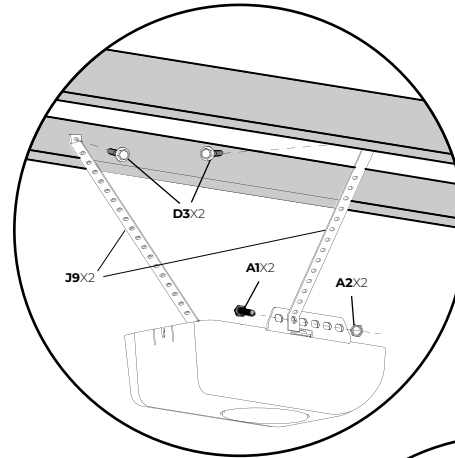

INSTALLATION

Step 5 – Install the door bracket

CAUTION

Doors made of lightweight steel, aluminum or fiberglass will require reinforcement (not provided) before installation of the door bracket. Contact door manufacturer for reinforcement instructions.

Sectional Doors

1. Center the door bracket [J8] along the vertical centerline.
2. Place the top edge of the door bracket 2"-4" (5cm – 10cm) below the top edge of the door.
3. Mark, drill holes and secure the door bracket based on the type of door you have.

One-Piece Doors

1. Center the door bracket on the top of the door along the vertical centerline.
2. Mark, drill holes and secure the door bracket based on the type of door you have.

Metal, insulated, lightweight with factory reinforcement or vertical angle brace between the door panel support and the door bracket:

- Drill 3/16" pilot holes, then secure the door bracket using the self threading screws [E3].

Non-insulated single layer door

- Use two 5/16"-18x2" bolts, lock washers and nuts (not provided)

Wood doors

- Drill 5/16" holes through the door and secure door bracket with 5/16" – 18X2" carriage bolts, lock washers and nuts (not provided)

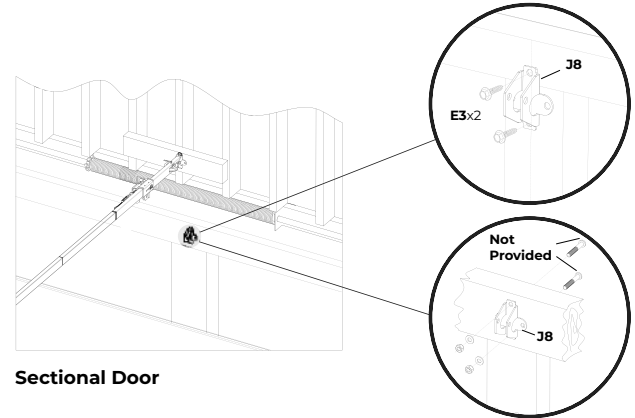

Sectional Door

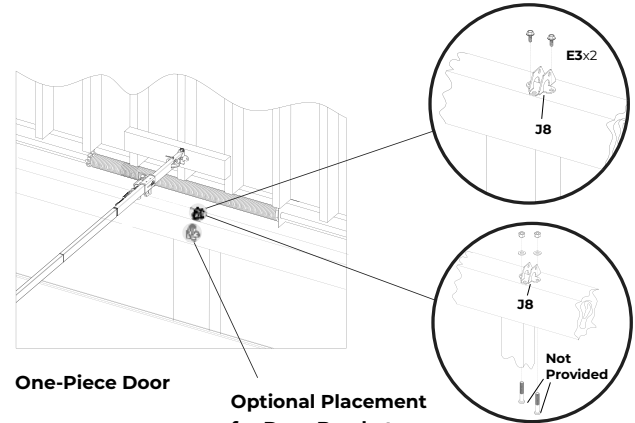

One-Piece Door

Optional Placement for Door Bracket

INSTALLATION

Step 6 – Attach door arm to trolley & door bracket

Follow the installation instructions below based on the type of door you have.

Sectional Doors

1. Attach the straight door arm [J10] to the trolley [J3] using the clevis pin [F1], secure with hitch pin [F2].
2. Install the curved door arm [J11] inside the door bracket [J8] using the clevis pin [E1], secure with hitch pin [E2].
3. Attach the curved and straight door arms together to the longest possible length. Attach using bolts [F3] and nuts [F4].

One-Piece Doors

1. Bring the curved and straight door arms together to the longest possible length. Attach using bolts [F3] and nuts [F4].
2. Attach the straight door arm to the door bracket using the clevis pin [E1], secure with hitch pin [E2].
3. Attach the curved door arm to the trolley using the clevis pin [F1], secure with hitch pin [F2].

Sectional Door

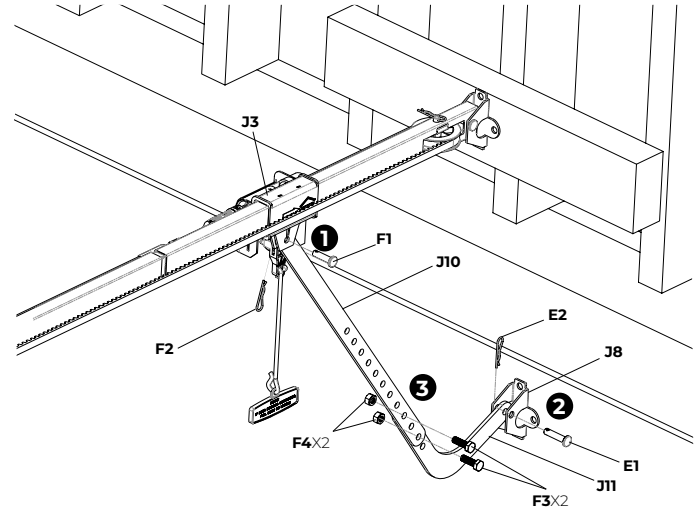

One-Piece Door

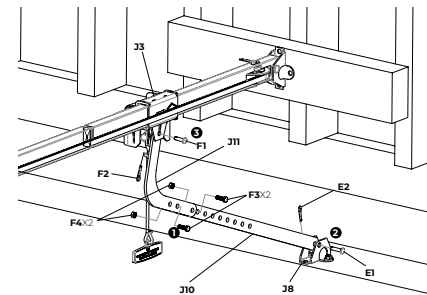

INSTALLATION

Step 7 – Lift door to connect trolley

1. Ensure trolley release arm is in horizontal position.
2. Open the door until you hear a click, so the trolley is connected to the turnbuckle.
3. Grasp the bottom of the door and open the door slowly by hand so the trolley moves towards the turnbuckle.

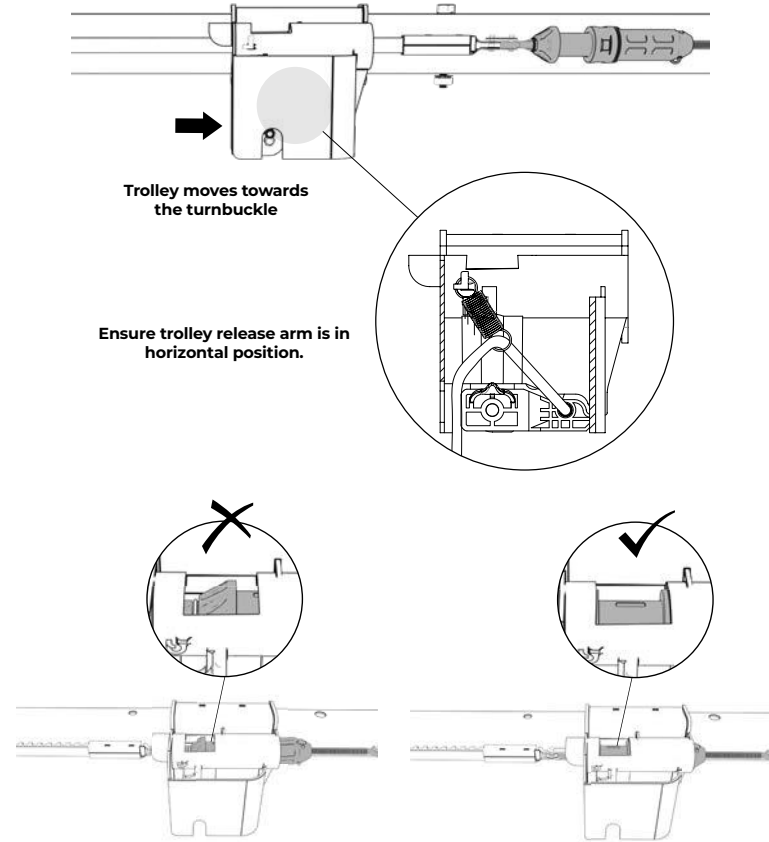
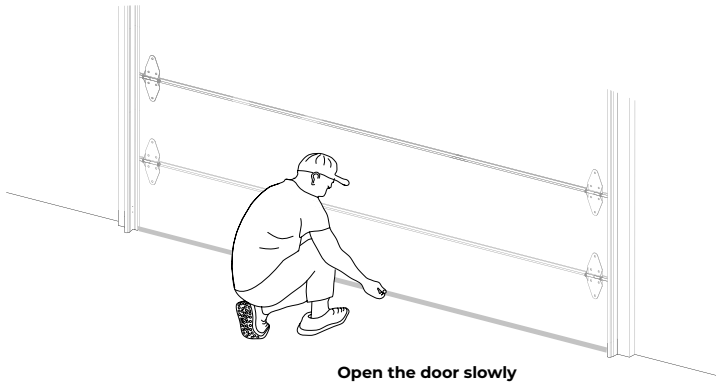

INSTALLATION

Step 8 – Install the door control

WARNING

- Install door control within sight of garage door.
- Door control must be at least 5 ft (1.5 m) above floors.
- Never permit children to operate door control.
- Always keep garage door in sight until door is fully closed.
- Do not operate door unless it can be seen clearly.

Skylink offer 3 different types of door controls:

- 1) Push Button
- 2) Deluxe Wall Console
- 3) LCD Wall Console

Follow the installation instructions below based on the type of door control you have.

Push Button & Deluxe Wall Console

1. Remove the insulation from one end of the wire and separate the wires.
2. Connect one wire to each of the two screws on the back of the door control. The wires can be connected to either screw.
3. Position the door control at least 5 ft (1.5m) above floors. Mark the locations of the 2 mounting holes and drill two 5/32 inch holes.
4. Install the screws and drywall anchors (if necessary) and secure the door control onto the wall.

LCD Wall Console

1. Remove the mounting plate on the back of the LCD wall console by sliding it out.
2. Position the mounting bracket at least 5 ft (1.5m) above floors. Mark the locations of the 2 mounting holes with the mounting plate, and drill two 5/32 inch holes.
3. Install the screws and drywall anchors (if necessary) and secure the mounting plate onto the wall.
4. Slide and secure the LCD wall console to the mounting plate.

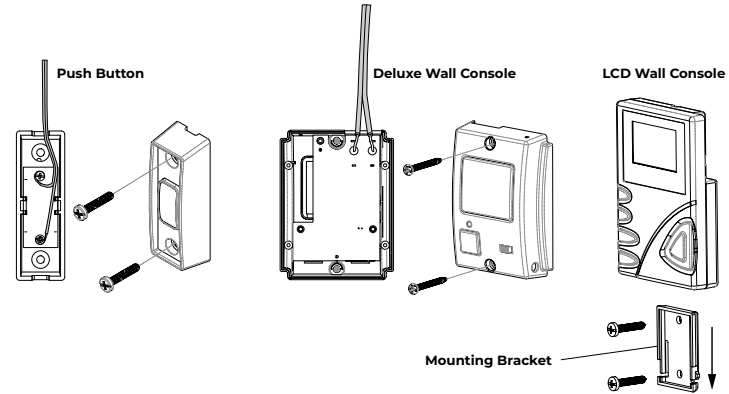
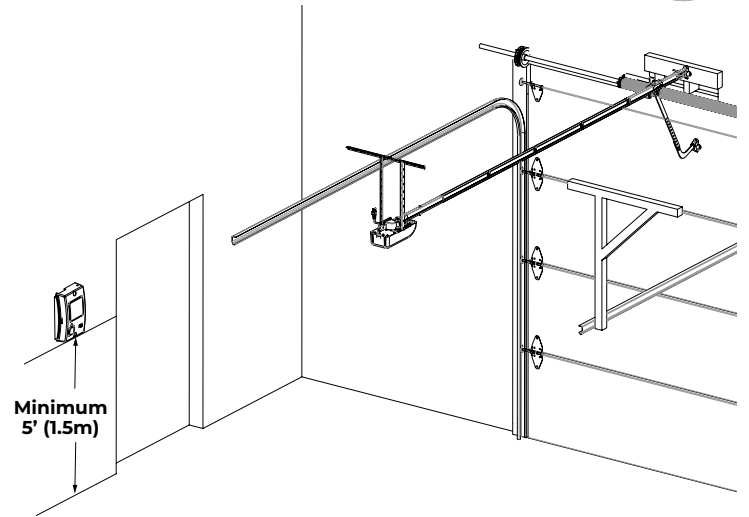

INSTALLATION

Step 9 – Wire the door control to the garage door opener

1. Uncoil the wires and run them from the door control to the garage door opener. If you attach the wire to the wall and ceiling with the staples (not provided), do not pierce the wire with the staple as this may cause a short or an open circuit.
2. Remove the insulation from the end of the wire near the garage door opener.
3. Connect the 2 wires to the door control terminals **!** on the garage door opener. To insert or release wires from the terminal, push in the tab with screwdriver tip. The wires can be connected to either terminal.

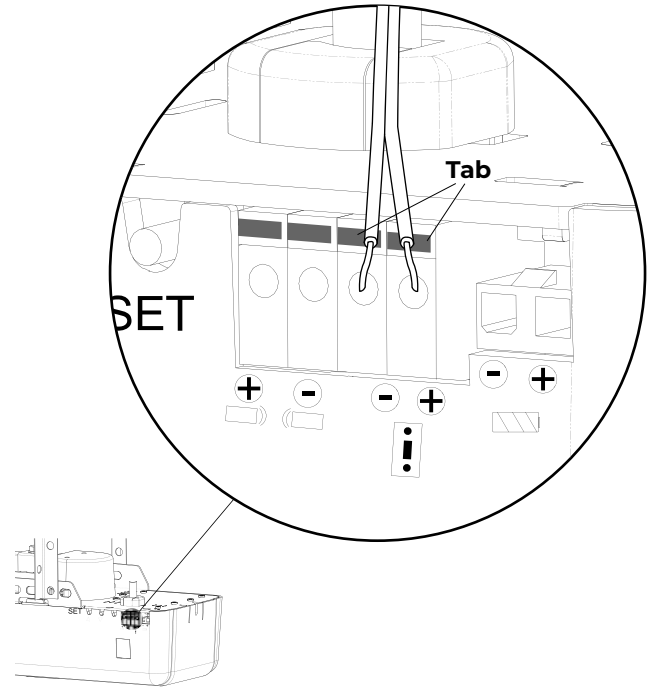

INSTALLATION

Step 10 – Install the Safety Beam Sensors

The safety beam sensors [J13] can be installed in 3 different ways:

- 1) Door Track Installation (Preferred and easiest)
- 2) Wall Installation
- 3) Floor Installation

Door Track Installation

Slide the curved portion of the sensor bracket around the outside edge of the door track. Snap into place so the sensor bracket is flush against the track.

Note: Ensure both sensor brackets should have the same height from the floor.

Wall Installation

1. Remove the curved portion from the sensor bracket.
2. Position the sensor bracket against the wall with the sensor facing the door.
Make sure there is enough clearance for the beam to be unobstructed. Mark 2 mounting holes.

Note: If additional clearance is needed, wooden blocks can be used. Make sure each bracket has the same amount of clearance so they align properly.

3. Drill 3/16 inch pilot holes for each sensor bracket and attach the sensor brackets to the wall using lag screws [H2].

Floor Installation

1. Remove the curved portion from the sensor bracket.
2. Place both sensor brackets on the floor facing each other with the same distance from the wall without any obstruction.
3. Attach the sensor brackets to the floor using concrete anchors (not provided).

Door Track Installation

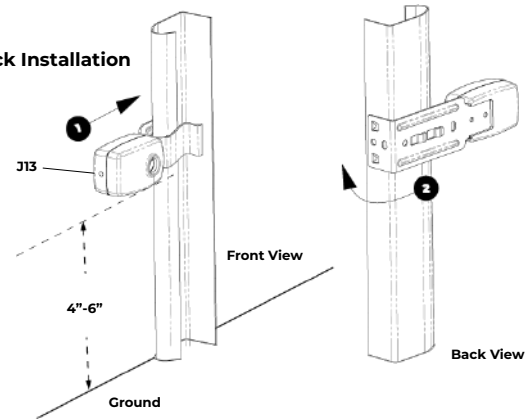

Wall / Floor Installation

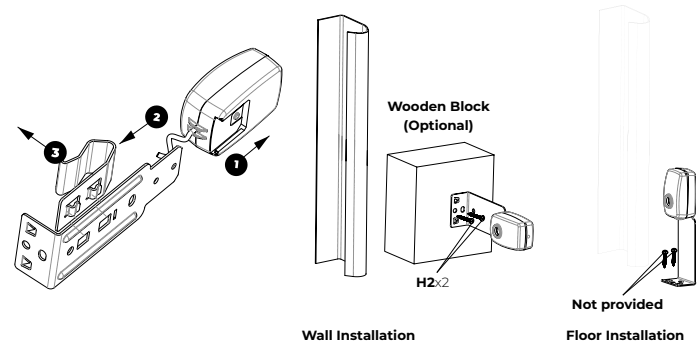

INSTALLATION

Step 11 – Wire the Safety Beam Sensors

1. Run the wire from both sensors to the garage door opener. Attach the wire to the wall and ceiling with the wire clips.
2. Remove insulation from each set of wires. Separate the wires. Twist the two white non-marked wires together. Twist the two white marked wires together.
3. Connect 2 pairs of twisted wires to the safety beam sensor terminals () () on the garage door opener. To insert or remove the wires from the terminal, push in the tab with a screwdriver tip. Each pair of twisted wires can be connected to either terminal.

Step 12 – Connect power

WARNING

- Disconnect power before removing cover for permanent wiring.
- Never use an extension cord, 2-wire adapter or change plug in any way.
- All wiring must be in compliance with all local electrical and building codes.

There are 2 options for connecting power:

1. AC Plug (Preferred & easiest)

1. Plug in the garage door opener into a grounded outlet.
2. Do not run garage door opener at this time.

2. Permanent Wiring by electrician

1. Cut existing power code outside chassis.
2. The wire connections must be made inside chassis and there must be at least 6" of new power supply line wire inside chassis.
3. The opener must be grounded.

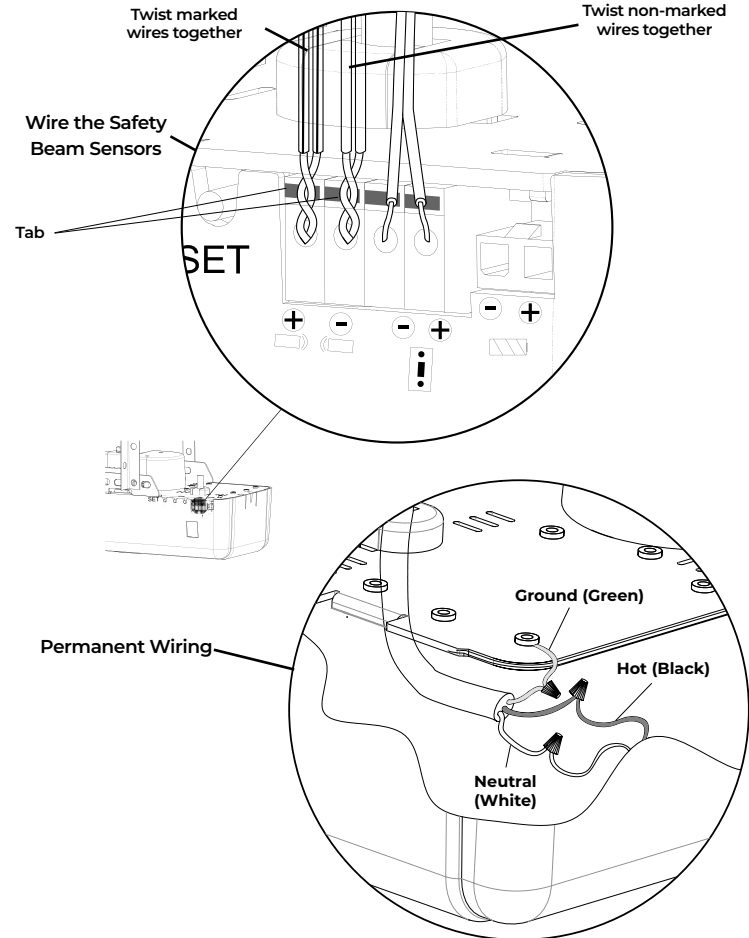

INSTALLATION

Step 13 – Aligning the safety beam sensors

Safety beam sensors must be installed and aligned correctly for the garage door opener to operate properly.

1. Both safety sensors should be facing each other without any obstruction.
2. Check to make sure the LEDs in both sensors are glowing steadily.
The LEDs in both sensors will glow steadily if they are aligned and wired correctly. Further alignment is necessary if any LEDs are not glowing steadily.

Red LED is the transmitting sensor, Blue LED is the receiving sensor.

If the Red LED is not glowing, please check the followings:

1. Make sure the garage door opener is plugged into AC power.
2. Make sure the sensor wires are not shorted / broken.
3. Ensure the sensor has been wired correctly. White non-marked wires are twisted together and insert to one safety sensor terminal. White marked wires are twisted together and insert to another safety sensor terminal.

If the Blue LED is not glowing, please check the followings:

1. Make sure the sensors are aligned. Reposition the sensor bracket until the Blue LED is glowing steadily.
2. Make sure the sensor wires are not shorted / broken.

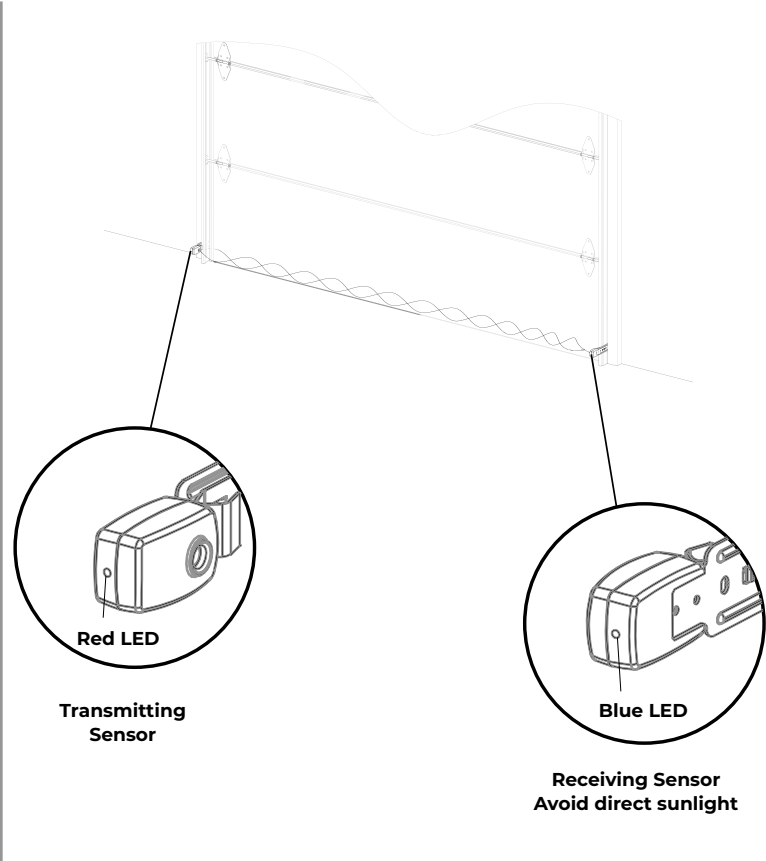

PROGRAMMING

Step 1 – Programming remote / keypad

1. Press and release the “**SET**” Button, the LED display shows “**P**”.
2. Press the button on the remote that you would like to program.
For keypad, enter the **[PIN] [#]**. Refer to page 28 for more information.
3. Once the remote / keypad is programmed, the LED display will be off and you will hear one beep.



NOTE

Each programming step has a 30-second time limit for completion after the function is initiated. Restart the step as many times as necessary to complete the programming. Each button on each remote must be programmed separately.

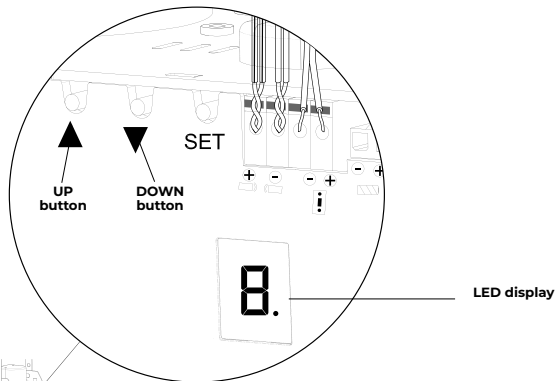

Step 2 – Programming the travel limits



WARNING

- Incorrect adjustment of garage door travel limits will interfere with proper operation of safety reversal system.
- After making any adjustment, both safety beam sensors and safety reversal system must be tested.

1. Press and hold the “**SET**” Button for 5 seconds until the LED display shows “**!**”.
Note: Do not release the “SET” button when you see “P” on the LED display.
2. Press and hold the **UP** Button ▲ until the door is in the desired fully open position.
*Note: Use the DOWN button if the door opens too far. Press **UP / DOWN** button momentarily to adjust the open travel limit as necessary.*
3. Once the door is in the desired fully open position, press and release the “**SET**” Button. The LED display will show “**2**”.

IMPORTANT NOTE: For one-piece door installations refer to page 28.

PROGRAMMING

4. Press and hold the DOWN button ▼ until the door is 2" from the ground.

Press **DOWN** button ▼ momentarily to inch downward slowly until the door is in the desired fully closed position.

Note: Door should rest on the floor until the weather strip is partially compressed. Damaged doors or uneven doors may not seal properly. Repair these conditions to achieve a proper seal. DO NOT set the door close limit too far down that the rail or door will bend or buckle.

5. Once the door is in the desired fully closed position, press and release the **"SET"** Button. The LED display will show "3".

6. Press the remote or door control to open the door. The door will open to the fully open position. The LED display will show "4".

7. Press the remote or door control to close the door. The door will close to the fully closed position. The LED display will be off.

8. You have programmed the travel limits successfully.

Step 3 – Vehicle Programming (In-Car Remote)



WARNING

Before programming, make sure that people and objects are out of the way of the garage door. The garage door will open and close during programming. DO NOT proceed vehicle programming if people or pets are in the path of the garage door.

1. Clear the In-Car Remote by holding on to the first and third buttons for 20 seconds. Clearing the In-Car Remote will erase all previously programmed garage door openers.
2. Press and hold the Skylink remote button for 10 seconds until the LED flashes rapidly.
3. Choose the button on the In-Car Remote that will be used to open the door. Press and hold this chosen button until the indicator on the In-Car Remote blinks slow then fast. Once it blinks, release this button.

PROGRAMMING

Step 4 – Test safety reversal system

With the garage door open, lay a 2X4 board flat on the floor, centered under the garage door.

Press the door control to close the door. The door **MUST** stop and reverse when it makes contact with the 2X4 board.

If the door stops before contact the board or if it does not reverse on obstruction, increase the down travel limit, then repeat the test above. Repeat this process as needed until the door passes this test.

Step 5 – Test safety beam sensors

With the garage door open, place the garage door opener carton box in the path of the door.

Press the door control to close the door, the door will not move more than an inch (2.5cm) and the LED display will show “b”.

You may also check both safety sensor LEDs (red and blue). They should be on steadily. This indicates the system is working properly. If one of the LEDs is not on steadily, please refer to Step 13 to troubleshoot.

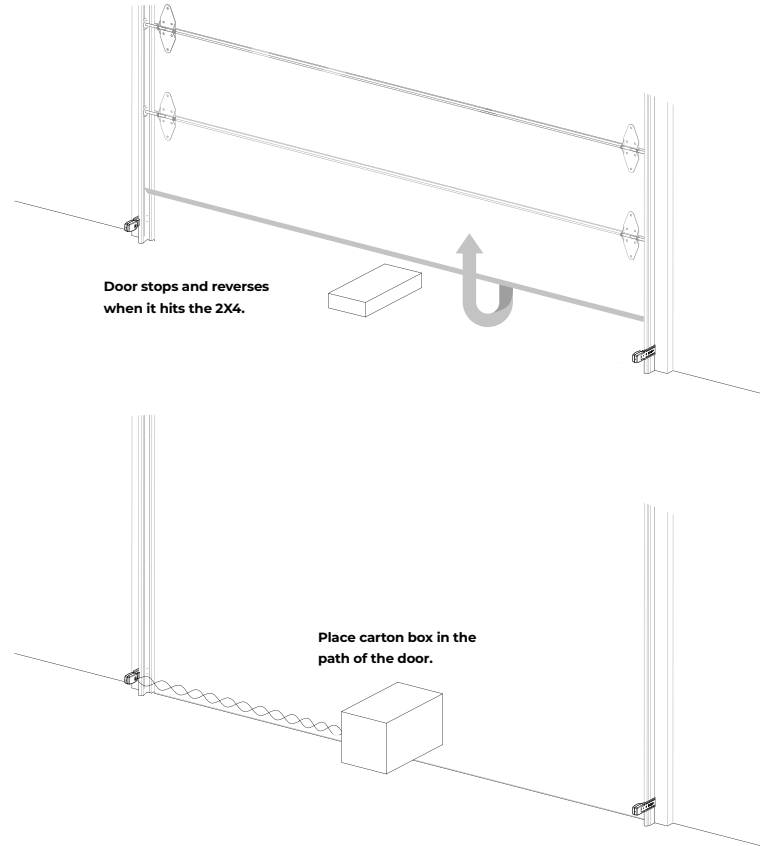

OPERATION



WARNING

IMPORTANT SAFETY INSTRUCTIONS

To reduce the risk of severe injury or death, read all instructions carefully.

1. Never let children to operate or play with garage door remote or door control.
2. Always operate garage door within sight and away from people / object until door is completely closed.
3. DO NOT cross the path of the moving door.
4. NEVER GO UNDER A STOPPED, PARTIALLY OPENED DOOR.
5. If possible, use emergency release handle to disengage trolley ONLY when garage door is CLOSED. Use caution when using this release with the door open. Weak or broken springs or unbalanced door could result in an open door falling rapidly and increasing the risk of severe injury or death.
6. Test the safety reversal system after making any adjustments.
7. Keep doors properly balanced. An improperly balanced door increases the risk of severe injury or death.
8. Have a trained door system technician make repairs to cables, spring assemblies, and other hardware.
9. Always disconnects all electric power to garage door opener before making any repairs or removing covers.

SAVE THESE INSTRUCTIONS

OPERATION

Manually Open / Close Garage Door

To open the door manually, first disconnect (disengage) the trolley.

1. Pull the emergency release handle towards garage door opener.
2. Pull the emergency release handle downward to the trolley release arm is in vertical position.
3. The door can now be opened manually.

To re-connect (engage) the trolley:

1. Pull the emergency release handle towards garage door opener until the trolley release arm is in horizontal position.
2. To re-connect the trolley, either activate the door control / remote control or open / close the door manually.
3. The trolley will re-connect when the turnbuckle makes contact with the trolley.

Disconnect Trolley

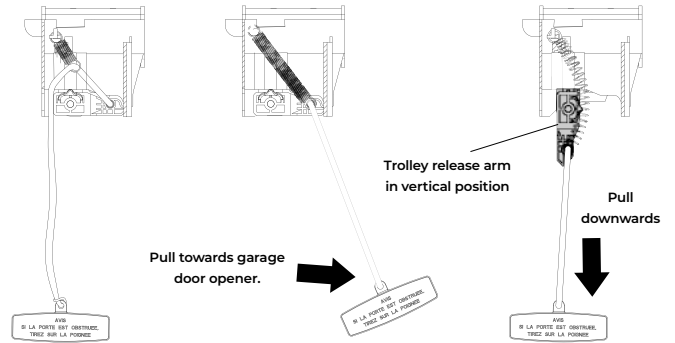

Connect Trolley

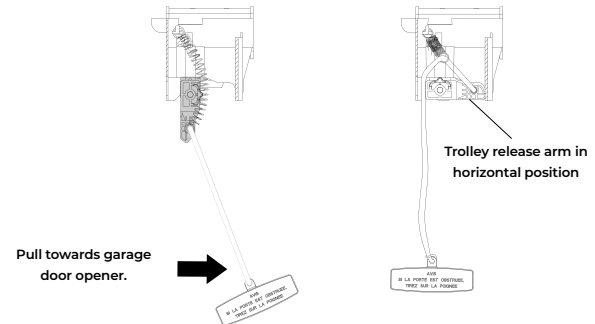

OPERATION

Remote Control

To operate the garage door opener with the remote, press the desired button on the remote control.

If the remote control does not operate the garage door opener, please follow instructions Page 23 Programming additional remote / keypad to program the remote control to the garage door opener.

Passcode Protection (ONLY for 3-Button Remote)

You can enable the passcode protection on the 3-button remote. Once enabled, passcode must be entered to unlock the remote before it can operate the garage door opener. The factory default setting is passcode function disabled.

To enable passcode protection:

1. Press and hold buttons 1 and 3 simultaneously 6 seconds until the LED flashes.
2. Enter the passcode (default passcode is 2 2 2), i.e. press button 2 three times.
3. Press and hold buttons 1 and 3 simultaneously, LED flashes once, passcode function is now enabled.

To change the passcode:

1. Press and hold buttons 1 and 3 simultaneously 10 seconds until the LED changes from flashing quickly to flashing slowly.
2. Enter the old passcode (default passcode is 2 2 2)
3. Press and hold buttons 1 and 3 simultaneously, if LED flashes once, enter the new passcode (from 2-8 digits). If LED flashes 3 times, you have entered the incorrect passcode. Start again from step 1.
4. After entering the new passcode, press and hold buttons 1 and 3 simultaneously to confirm.

Toggle between enable / disable passcode protection

1. Press and hold buttons 1 and 3 simultaneously 6 seconds until the LED flashes.
2. Enter the passcode (default passcode is 2 2 2), i.e. press button 2 three times.
3. Press and hold buttons 1 and 3 simultaneously, LED flashes once, passcode function is toggled, i.e. from disable to enable, or enabled to disabled).

Forgot Passcode and Factory Reset

If you forgot your passcode or would like to change the passcode to factory default 2 2 2, follow the steps below.

1. Press and hold buttons 1 and 2 for 10 seconds until the LED flashes.
2. Release both buttons. Passcode function is now disabled and passcode is set to factory default 2 2 2.

Keypad

Keypad Installation

1. Undo the screw on the bottom of the keypad and remove back cover.
2. Insert the battery.
3. Secure the back cover with 2 screws at the selected location.
4. Slide the keypad unit to the back cover and secure with the bottom screw.

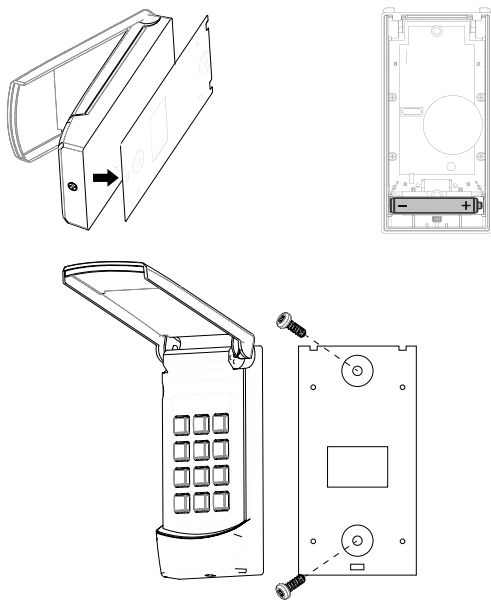

To operate the garage door opener with the keypad:

Enter the [PIN] + [#]. The factory default PIN is 0 0 0 0.

You can enter [0 0 0 0 #] to operate the garage door opener.

To change the PIN, follow the instructions below:

1. Enter the current PIN + [*], i.e. [0 0 0 0 *] if you are changing from factory default PIN.
2. Enter a new PIN (2 to 8 digits) + [*], such as [1 2 3 4 *].
3. Re-enter the new PIN again, [1 2 3 4 *].
4. If the new PIN is accepted, keypad will emit 3 beeps.
5. Try with the new PIN to operate the garage door opener by entering [New PIN] + [#].

It is not necessary to reprogram the keypad to the garage door opener after changing the PIN.

If the keypad does not operate the garage door opener, please follow instructions Page 23 Programming additional remote / keypad to program the keypad to the garage door opener.

Keypad

Reset PIN to factory default

1. Undo the screw an the bottom of the keypad and remove the battery.
2. Press and hold [*] and [#] while battery is removed.
3. While holding on to both buttons, insert the battery.
4. Keep holding both buttons for about 5 seconds until you hear a long beep.

The PIN is now reset to 0 0 0 0. Attach the keypad to the back plate and secure the screw at the bottom.

Re-program the keypad to the garage door opener following the instructions on page 22 "Programming remote / keypad".

Enable Multiple Doors Operating Mode

This keypad can operate up to 4 Skylink garage door openers. To enable multiple doors mode:

1. Enter [PIN] [*] [9] [#].
2. You will hear 2 beeps indicating keypad is now in multiple doors mode.

Program keypad in Multiple Doors Mode to Garage Door opener

1. Press "SET" button on the garage door opener, LED display will show "P".
2. Enter [PIN] [#] [Door #], Door # is either [1], [2], [3] or [4]

To control Multiple Doors:

Enter [PIN] [#] [Door #].

For example, to control door 2, enter [PIN] [#] [2]

Disable Multiple Doors

1. Enter [PIN] [*] [0] [#].
2. Press [0] [#]. You will hear 2 beeps indicating keypad is now in multiple doors mode.

OPERATION

Deluxe Wall Console offers 4 functions:

Door Control: Press this button to open / close the garage door.

Light Control: Press the light button to turn the garage door opener light on or off. Once it is turned on, it will stay on until this light button is pressed again. The garage door opener light will also be on during a door open / door close cycle, it will stay on for approximately 3 minutes.

Remote Lock: Slide to the lock position to disable the garage door opener from being activated by remote controls and wireless keypad. Slide to the unlock position to resume normal operation.

Auto-Close Timer: Auto-Close Timer allows the garage door to be closed automatically after a specific period of time. This feature can only be used for sectional door. It CANNOT be used on one-piece door. To disable Auto-Close Timer, place the slide switch setting to "Off" position to disable this feature.

To enable Auto-Close Timer, place the slide switch to the desired time setting, this is how long the door will remain open before auto closing:

- 3 – 3 Minutes
- 10 – 10 Minutes
- 30 – 30 Minutes

1) If Auto-Close Timer is enabled, the timer will start once the door is open. The LED display will show "A" to indicate Auto-Close Timer is counting down.

The garage door opener will emit beeping and flashing alert before closing the door. If the garage door cannot be closed completely due to any reason, such as obstruction is detected, or safety beam sensors being blocked, the opener will try to close it for up to 5 times. When the obstruction or safety beam sensors are clear, the opener will close again when activated.

2) If you would like to disable Auto-Close while it is counting down, press the door control button once. It will disable the Auto-Close for that cycle. Pressing the door control button again will close the door immediately.

Auto-Close Timer

Door Control

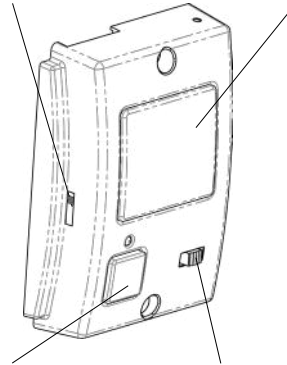

Light Control

Remote Lock

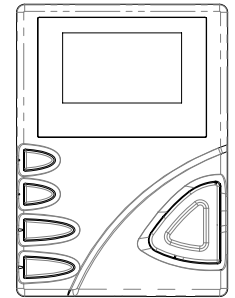

For LCD Wall Console operations, please refer to its instructions.

OPERATION

Erase Remote Control / Keypad from Memory

To erase all remote controls and keypads, follow the instructions below.

1. Press and hold the SET button for 15 seconds, until the LED display flashes "E", release "SET" button.
2. Press "SET" button once to confirm, the "E" disappear on the LED display. All remote controls and keypads are now erased.
3. Reprogram any remote control / keypad you would like to use.

MAINTENANCE

Perform the following maintenance tasks monthly to ensure garage door opener operates smoothly.

- Test the safety beam sensor and safety reversal system monthly, refer to page 24.
- Open and close door manually to ensure door operates properly.
- Check door balance, if door is unbalance, contact a trained door system technician.
- If chain / belt sags excessive below the rail, tighten the tension of the chain / belt. Open the door until the trolley is about mid travel, then stop. Disconnect the trolley then close the door manually. Adjust the tension of the chain / belt (refer to page 10). After adjusting the tension, manually open the door until the trolley connects to the turnbuckle.
- Lubricate door hardware such as rollers and hinges with light weight general purpose grease when needed.

MAINTENANCE

WARNING

To prevent possible serious injury or death:

- Never allow small children near batteries
- If battery is swallowed, notify doctor immediately
- Dispose old batteries promptly and properly

Battery Replacement – Remote Control and Keypad

Remote Control

Replace remote battery with a lithium coin cell CR-2032 battery.

1. Undo 2 screws on the bottom of the remote.
2. Slide out the old battery and slide in the new one. Note the polarity, positive side up.
3. Secure the plastic housing with 2 screws.

Keypad

Replace keypad with one AAA alkaline battery.

1. Undo the screw on the bottom of the keypad and remove back cover.
2. Replace battery with one AAA alkaline battery and check the polarities.
3. Secure the plastic housing with the screw on the bottom.

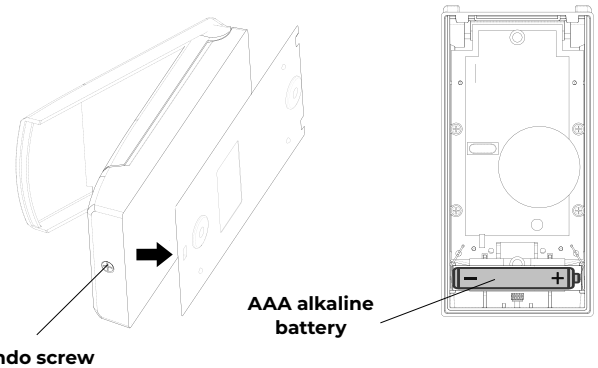
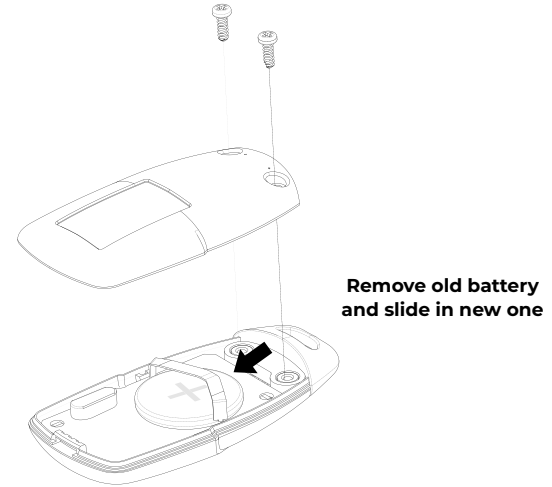

Wi-Fi CONNECTIVITY

Smartphone Control - Wi-Fi



Smartphone Control allows you to control and monitor your garage door opener with the smartphone app "Orbit Home".

Requirements:

1. 2.4GHz Wi-Fi Network, 802.11 b/g/n in the garage (5GHz network not supported) with broadband internet connection.
2. Password for Wi-Fi Network.
3. Mobile device with iOS or Android with Orbit Home App.
4. Wi-Fi adapter and compatible Skylink garage door opener.

To setup Wi-Fi adapter:

1. Plug in the Wi-Fi adapter to the garage door opener as shown.
2. Red LED on the Wi-Fi adapter should be steadily on.
3. Download the app from either iOS App Store or Google Play Store, "Orbit Home".
4. Setup the your account and add the garage door opener following the instructions on Orbit Home app.



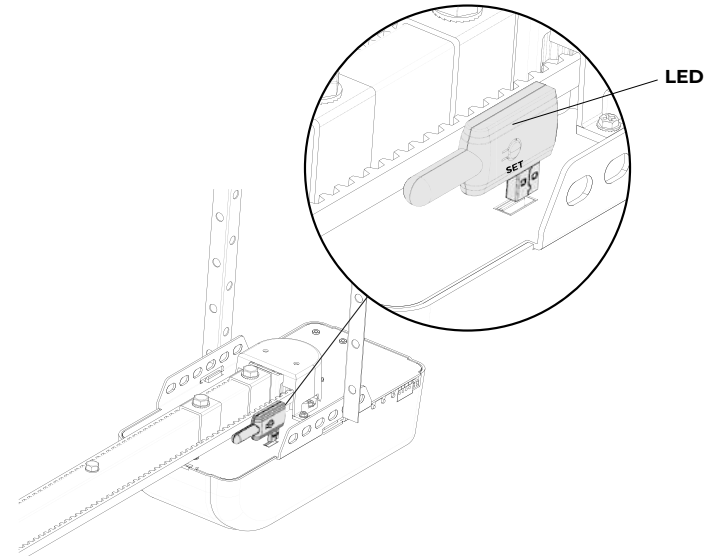



The garage door opener will emit beeping and flashing alert when closing garage door with the smartphone app. This is a safety feature to alert anyone near the garage that the door is about to close. This alert cannot be disabled. If the garage door cannot be closed completely due to any reason, such as obstruction is detected, or safety beam sensors being blocked, the opener will reverse to fully open position.



Wi-Fi Adapter LED Indication

LED	STATUS
Red On Steadily	Powered but not connected to Wi-Fi
Red Flashing	Advanced Wi-Fi Setup
Blue On Steadily	Connected to Wi-Fi
Blue Flashing	Quick Connect Wi-Fi Setup
Red - Blue Alternating Flashing Continuously	Connected to home network but not internet server.

TROUBLESHOOTING - ERROR CODE

LED LIGHT FLASHING	LED DISPLAY	SYMPTOM	SOLUTION
10 Flashes		Safety Beam Sensors not functioning properly when door is closing.	<ul style="list-style-type: none"> - Check safety beam sensors alignment. - Check any obstacle blocking safety beam path. - Check sensors LEDs to troubleshoot further. (refer to Page 21 Aligning the safety beam sensors)
15 Flashes		Door is not fully closed or fully open due to force exceeded the limit.	<ul style="list-style-type: none"> - Check operating condition of the door, ensure the door can operate smoothly. - Check the chain / belt tension, do not over-tight. - Re-program travel limits if problem persists.
3 Flashes		The door control is in lock mode, remote and keypad cannot function.	Unlock "Remote Lock"  on the door control.
Continuous Flashing		Door control wires are shorted.	Check the door control wiring, ensure the 2 wires are not shorted on both ends, the door control's terminal and the door opener's terminal.
5 Flashes		Door open or close cycle exceeds 30-second.	<ul style="list-style-type: none"> - This is a safety requirement not to allow a door open or close cycle exceeds 30 seconds. The opener will stop when opener has been run for 30 seconds. - Check door for binding, lubricate rollers or hinges. - Check operating condition of the door, ensure door is balanced properly. Contact a trained door technician for service if needed.

TROUBLESHOOTING

SYMPTOM	SOLUTION
Opener works from door control, but not remote control.	<ol style="list-style-type: none"> 1. Ensure Remote Lock on the Deluxe / LCD Wall Console is disabled. 2. Reprogram the remote. 3. Replace remote battery.
Door reverses after it's completely closed.	<ol style="list-style-type: none"> 1. Check for any obstacles on the ground in the path of the door stopping the door to close completely. 2. Re-program the down travel limit to avoid door closing too far down. Refer to "Programming the travel limits" to set the travel limit.
Door opener runs very slow.	<p>Check operating condition of the door, ensure the door is balanced properly. Contact a trained door technician for service if needed.</p>
Door will not close and LED display showing "b".	<p>"b" indicates safety beam sensor is blocked while door is closing. Check the following:</p> <ol style="list-style-type: none"> 1. Ensure the safety beam sensors are installed and wired properly. Refer to "Install the safety beam sensors". 2. Ensure both red and blue LED on the safety beam sensors are steadily on. Refer to "Aligning the safety beam sensors" to check the LED status and sensor alignment. 3. If problem exists and door will not close, the opener can be forced to close by pressing and holding the door control door button until the door is completely closed. CAUTION: Keep garage door in sight until the door is fully closed, then release the door button.
Door will not close and LED display shows "F"	<ol style="list-style-type: none"> 1. Check door for binding, lubricate rollers or hinges if needed. Refer to "Regular Maintenance". 2. Check operating condition of the door, ensure the door is balanced properly. Contact a trained door technician for service if needed. 3. Check the chain / belt tension. "F" will show up if the chain / belt is overtightened. Loosen up the tension a bit to the desired tension. Refer to "Tighten the chain / belt" for more information.
When opener is activated, turnbuckle moves but door does not.	<p>Ensure the trolley is connected to the turnbuckle. Refer to "Manually Open / Close Garage Door" to connect the trolley properly.</p>
Travel limit changes on a belt drive opener	<p>Ensure the belt's tension is not too loose which may cause the belt to slip resulting in changing the travel limit. Refer to the section "Tighten the chain / belt" to adjust the tension.</p>

TROUBLESHOOTING

Door will not stop and reverse while closing when safety beam sensor is blocked, but it will reverse when safety beam sensor is blocked while opening.

Check if the trolley is installed on the correct side of the rail. Stand under the motor unit facing the garage door. Look up and see if the trolley is on the left side of the rail or right side. Trolley should be on the left side of the rail. If the trolley is on the right side, refer to "Assemble the rail and insert the trolley" to install the trolley properly.

Door will not close completely or reverse in winter time.

Check any snow / ice accumulated at the bottom of the door or on the floor causing the door cannot be closed completely. Remove ice / snow if necessary.

Wi-Fi adapter has no LED

Try to remove the Wi-Fi adapter and plug it in again. You should see a red or blue LED above the SET button.

FCC

This device complies with Part 15 of the FCC Rules. Operation is subject to the following two conditions: (1) This device may not cause harmful interference and (2) This device must accept any interference received, including interference that may cause undesired operation.



NOTE

This equipment has been tested and found to comply with the limits for a Class B digital device, pursuant to Part 15 of the FCC Rules. These limits are designed to provide reasonable protection against harmful interference in a residential installation. This equipment generates, uses and can radiate radio frequency energy and, if not installed and used in accordance with the instructions, may cause harmful interference to radio communications.

However, there is no guarantee that interference will not occur in a particular installation. If this equipment does cause harmful interference to radio or television reception, which can be determined by turning the equipment off and on, the user is encouraged to try to correct the interference by one or more of the following measures:

- Reorient or relocate the receiving antenna.

- Increase the separation between the equipment and receiver.

- Connect the equipment into an outlet on a circuit different from that to which the receiver is connected,

- Consult the dealer or an experienced radio / TV technician for help.

SKYLINK LIMITED WARRANTY

WARRANTY ON SKYLINK GARAGE DOOR OPENER

LIMITED WARRANTY TO ORIGINAL CONSUMER PURCHASER WITH PROOF OF PURCHASE
 This SKYLINK brand product, as supplied and distributed by SKYLINK and delivered new, in the original carton to the original consumer purchaser (not transferable or assignable), is warranted by SKYLINK against manufacturing defects in materials or workmanship for the limited warranty period of:

WARRANTY PERIOD			
Model*	Group A	Group B	Group C
Motor	Lifetime	10 Years	6 Years
Chain	Lifetime	10 Years	5 Years
Belt	Lifetime	10 Years	5 Years
Parts	5 Years	3 Years	1 Year
Accessories	1 Year	1 Year	1 Year

Refer to model numbers below for different groups.

Group A: ATR-1723CK, ATR-1723CKW, ATR-1723BK, ATR-1723BKW

Group B: ATR-1622CK, ATR-1622CKW, ATR-1622BK, ATR-1622BKW, ATR-1722C, ATR-1722CK, ATR-1722CKW, ATR-1722B, ATR-1722BK, ATR-1722BKW

Group C: ATR-1611C, ATR-1611CW, ATR-1612C, ATR-1612CK, ATR-1612CKW, ATR-1612B, ATR-1612BK, ATR-1612BKW

This limited warranty is valid only on products purchased and used in the United States / Canada that have been installed, operated, and maintained according to the instructions attached to or furnished with the product. To receive warranty service, the purchaser must contact SKYLINK at the address or phone number provided below for problem determination and service procedures. Purchaser will be advised of disassembly and shipping instructions, then send the product or component, pre-paid and insured to SKYLINK. Purchaser must allow SKYLINK a reasonable opportunity to inspect the product claimed to be defective prior to removal or alteration of its condition. The original dated bill of sale must be presented upon request as proof of purchase to SKYLINK to receive warranty service.

During the applicable warranty period, a product will be repaired, replaced, or the purchase price refunded, at the sole option of SKYLINK. SKYLINK may use new or reconditioned parts in repairing a product, or replace the product with a new or reconditioned product.

Replacement parts and products are warranted for the remaining portion of the original product's warranty or ninety (90) days, whichever is longer. All replaced parts and products are the property of SKYLINK and you must return them to SKYLINK.

This limited warranty covers manufacturing defects in materials or workmanship encountered in normal residential household, non-commercial use of this product and shall not cover the following: damage that occurs in shipment, delivery, installation, and uses for which this product was not intended; damage caused by unauthorized modification or alteration of the product; product where the original factory serial numbers have been removed, defaced, changed in any way, or cannot be readily determined; cosmetic damage including scratches, dents, chips, and other damage to the product's finishes; damage caused by abuse, misuse, pest infestations, accident, fire, floods, or other acts of nature or God; damage caused by use of equipment, utilities, services, parts, supplies, accessories, applications, installations, repairs, external wiring or connectors not supplied or authorized by SKYLINK; damage caused by incorrect electrical line current, voltage, fluctuations and surges; damage caused by failure to operate and maintain the product according to instructions; in-home instruction on how to use your product; and service to correct installation not in accordance with electrical codes or correction of household electrical (i.e., house wiring, fuses); and does not cover batteries, missing or damaged parts from clearance or open box sales. The cost of repair or replacement under these excluded circumstances shall be the customer's responsibility.

EXCLUSION OF IMPLIED WARRANTIES

IMPLIED WARRANTIES, INCLUDING THE IMPLIED WARRANTIES OF MERCHANTABILITY OR FITNESS FOR A PARTICULAR PURPOSE, ARE LIMITED TO ONE YEAR OR THE SHORTEST PERIOD ALLOWED BY LAW.

Some states and provinces do not allow limitations on how long an implied warranty lasts, so the above limitations or exclusions may not apply to you. This limited warranty gives you specific rights, and you may also have other rights, which vary from state to state and province to province.

LIMITATION OF REMEDIES

YOUR SOLE AND EXCLUSIVE REMEDY IS PRODUCT REPAIR, PRODUCT REPLACEMENT, OR REFUND OF THE PURCHASE PRICE AT SKYLINK'S OPTION, AS PROVIDED IN THIS LIMITED WARRANTY. SKYLINK SHALL NOT BE LIABLE FOR SPECIAL, INCIDENTAL OR CONSEQUENTIAL DAMAGES, INCLUDING BUT NOT LIMITED TO TIME AWAY FROM WORK, HOTELS AND/OR RESTAURANT MEALS, REMODELING EXPENSES, LOSS OF REVENUE OR PROFITS, FAILURE TO REALIZE SAVINGS OR OTHER BENEFITS REGARDLESS OF THE LEGAL THEORY ON WHICH THE CLAIM IS BASED, AND EVEN IF SKYLINK HAS BEEN ADVISED OF THE POSSIBILITY OF SUCH DAMAGES. Some states and provinces do not allow exclusion or limitation of incidental or consequential damages, so the above limitations or exclusions may not apply to you. This warranty gives you specific rights, and you may also have other rights, which vary from state to state and province to province.

SKYLINK does not warrant uninterrupted or error-free operation of the product. No warranty or guarantee given by any other person, firm, or corporation with respect to this product shall be binding on SKYLINK.

To obtain warranty service, please contact SKYLINK at:
 1-800-304-1187
 support@skylinkhome.com