

S

E

R

A

I

Gate Openers Department

INSTALLATION GUIDE

MERCURIO 300 F SR 24.75F KIT FOR SLIDING GATE UP TO 300 Kg

MERCURIO 500 F SR 24.85F KIT FOR SLIDING GATE UP TO 500 Kg

MERCURIO 800 F SR 24.45F KIT FOR SLIDING GATE UP TO 800 Kg

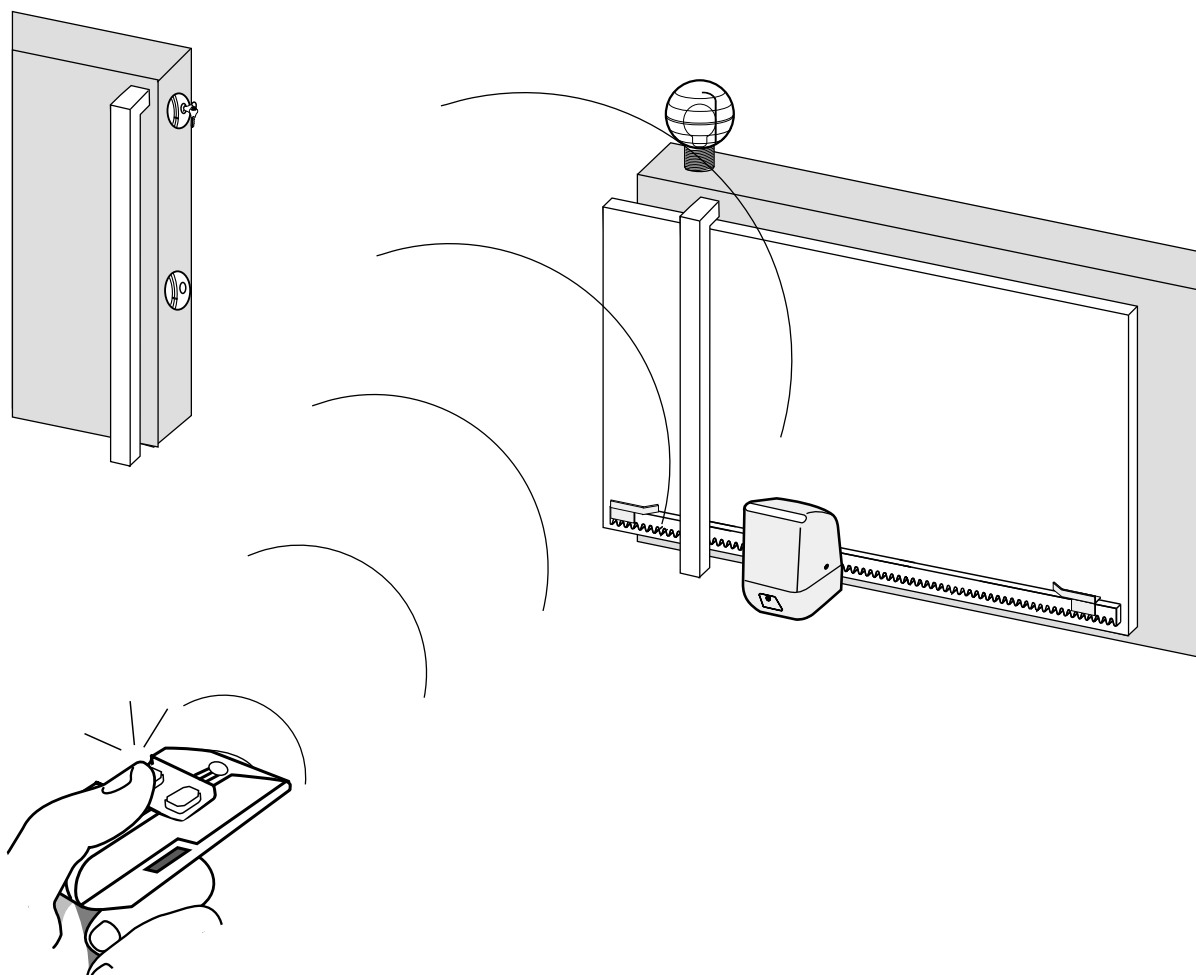

ATTENTION: PLEASE, READ CAREFULLY THIS GUIDE BEFORE ANY WIRE CONNECTION, AND KEEP IT FOR FUTURE CONSULTATION

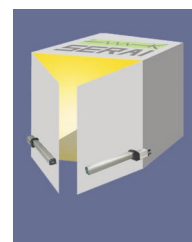

We thank you for the preference given to SERAI ELETTRONICA, certain that you will obtain from this product the performances necessary to its use.

We remind you that you are going to install a **system** classified as “ powered system destined to the automatic doors and gates movement in commercial or residential buildings, with vehicules and people access.” It has to be considered “**potentially dangerous**”. According to the law, it is your duty and responsibility to make “ safe “ the system.

Installation and maintenance must be carried out exclusively by qualified, skilled and expert personnel, with “ craftmanslike” installations, as foreseen by the current laws in the Country where the installation is made . **Laws forbid the installation of such devices by not qualified personnel.**

Producing these devices SERAI spa has respected the following normatives:

Referring standard for CE marking:

Systems.	98/37/CEE
Low voltage:	73/23/CEE
Electromagnetical compatibility	89/336/CEE
R&TTE (radio products)	99/5/CEE

Generical reference laws:

Electrical safety:	CEI EN60335-1
Electromagnetical compatibility-emission	CEI EN50081-1
Electromagnetical compatibility-immunity	CEI EN50082-1

During system installation, please, respect also the following normatives, besides the previous.

Generical reference laws:

Electrical system security in general places: see specific laws in force in the Country where the installtion is made

Reference laws on specific product:

Security using motorized gates requirements:	UNI EN12453
Security using motorized gates methods for testing:	UNI EN12445

SERAI spa products are suitable to carry out systems respecting these normatives. We remind you again that it is very important, because the system responsibility and an “ according to law” functioning are a duty of the Installer.

This installation guide must be read at least once before installing the system.

The installation of mechanical stop-blocks for opening and closing phase is necessary to guarantee system security and therefore it is compulsory to install them, before installing the control panel.

INDEX

	Page
PART 1: GENERAL	4
1.1 Kit composition	4
1.2 Example of kit electrical connection	4
PART 2: MOTOR INSTALLATION	5
2.1 First of all	5
2.2 Install the baseplate	5
2.3 Opening of the motor	6
2.4 Positioning of the motor	6
2.5 Motor unlocking system	6
2.6 Toothrack installation	7
2.7 Limit switch installation	8
2.8 Final fixing of the motor	8
PART 3: ELECTRONIC CONTROL PANEL	9
3.1 Technical data and electrical connection CR/34 (MERCURIO 300-500)	9
3.2 Technical data and electrical connection CR/34C (MERCURIO 800)	9
3.3 Ground connection	10
3.4 Motor connection	10
3.5 Adjustment of the motor power	10
3.6 Trimmers' function	10
3.7 Normal functioning setting	11
3.8 Dip-switch setting	11
3.9 LED signalling	12
PART 4: CARD RECEIVER SOG/4	13
4.1 Card receiver installation	13
4.2 Transmitter memorization on the receiver card	14
4.3 Programmed transmitter reset	14
PART 5: PHOTOCELLS P/10	15
5.1 Technical data	15
5.2 Installation position	15
5.3 Installation	15
5.4 Alignment control	16
PART 6: TECHNICAL DATA OF THE MOTOR	17
PART 7: MANUAL UNLOCKING GATE SYSTEM	18
PART 8: PROBLEM GUIDE	18

PART 1: GENERAL

1.1 KIT COMPOSITION

- | | |
|--|---|
| <p>1. a- Motor MT/300
MT/500
MT/800</p> <p>b- Electronic control panel
- CR/34 for MERCURIO 300-500
- CR/34C for MERCURIO 800</p> <p>c- Card receiver SOG/4</p> <p>d- Unlocking keys</p> <p>e- Grub screws M8 for motor adjustments</p> | <p>3. a- Limit switch plates
b- Grub screws M6 for plates fixing</p> <p>4. Pair of photocells P/10 with plugs</p> <p>5. Mini transmitter OG/52</p> <p>6. Inside Antenna</p> |
| <p>2. a- Baseplate
b- Bolts
c- Nuts
d- Washers</p> | |

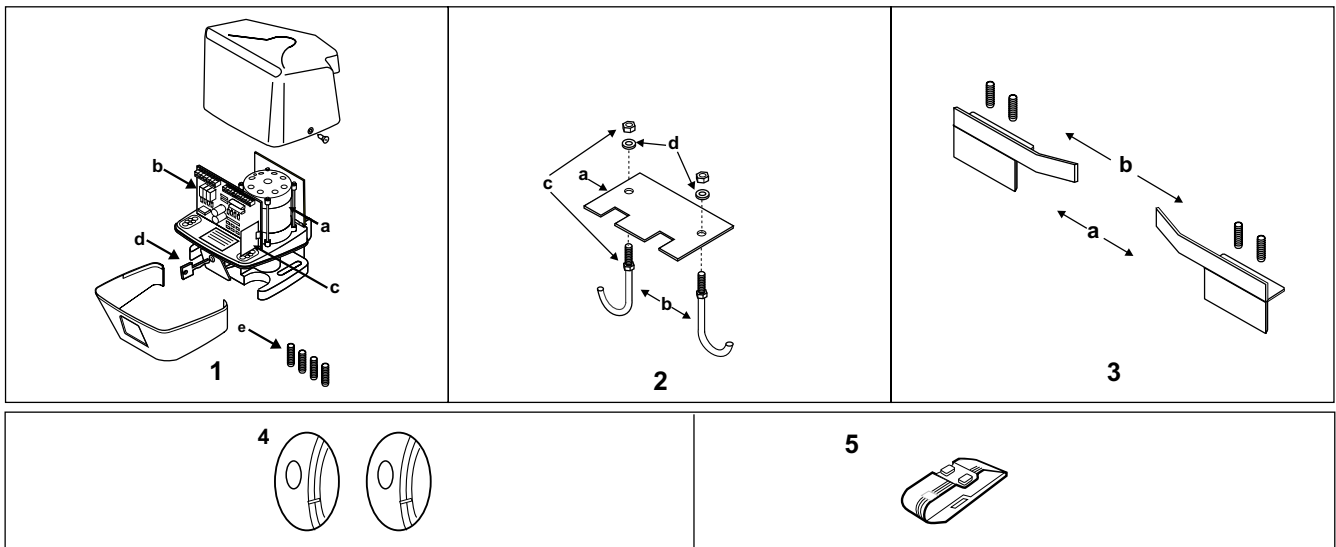

1.2 EXAMPLE OF KIT ELECTRICAL CONNECTION

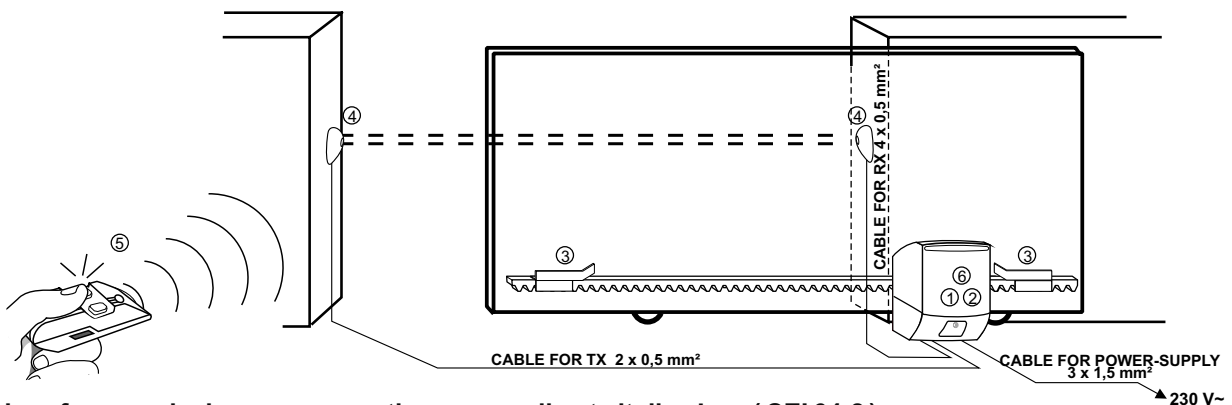

Advices for generical space connections, according to italian Law (CEI 64-8).

- Predispose at the bottom of the system an omnipolar disconnecting switch with distance between contacts of 3 mm or more. On alternative choice it is possible to use a magnetothermic switch of 10A.
- Make any kind of connections with no power supply on the system, or with the disconnecting switch on " open " position (symbol "0"). Particularly, the control panel must never be supplied during the wiring, nor when inserting the expansion cards.
- During the installation use following wires.
 - For control panel, motors and electrical lock power supply: section 1,5mm² for max. lenght of 19m, section 2,5mm² for lenght up to 31m.
 - for the flashing light: section 0.75mm² for max. lenght of 3m, section 1.5mm² for lenght up to 19m
 - for low voltage lines and current, such as photocells, command buttons, electromechanical key, sensitive edge and other safety devices: section 0.5mm² for max. lenght of 50m, section 0.75mm² for lenght up to 100m.
- Please carry out the ground connection as forseen by laws.

PART 2: MOTOR INSTALLATION

2.1 FIRST OF ALL

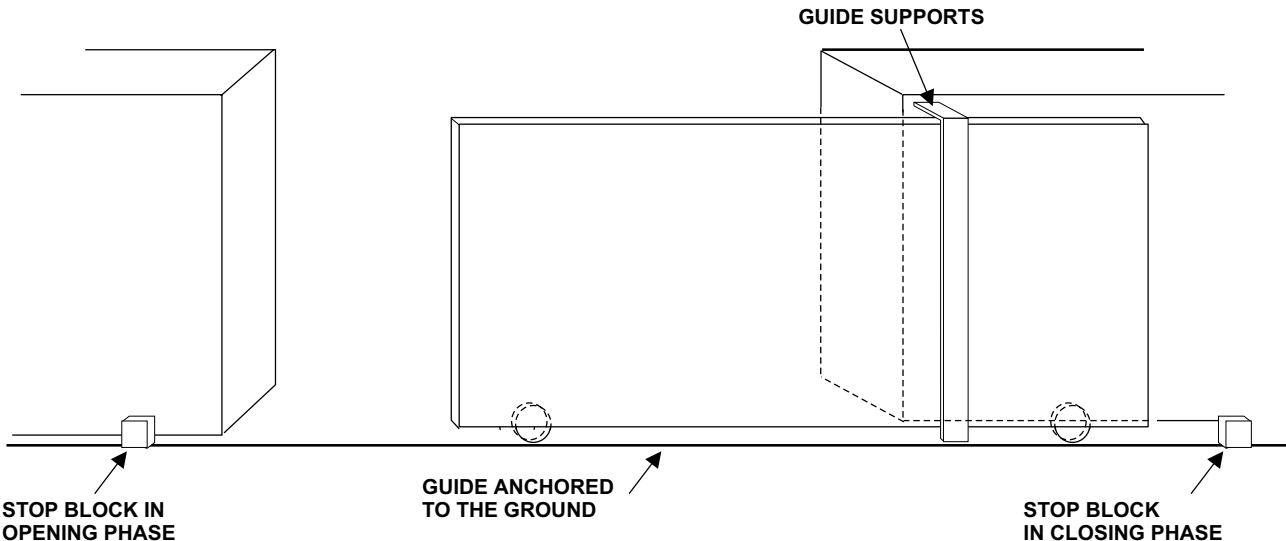

The diagram illustrates the initial installation steps for a gate. It shows a side view of a gate with a track. Key components are labeled: 'GUIDE SUPPORTS' at the top of the track, 'GUIDE ANCHORED TO THE GROUND' at the bottom of the track, and 'STOP BLOCK IN OPENING PHASE' and 'STOP BLOCK IN CLOSING PHASE' at the ends of the track. Below the diagram is a list of instructions and an attention warning.

- Check that the gate has strong guide supports
- Check that the guide is strongly anchored to the ground
- Install two mechanical stop-blocks on the two side
- Check that the gate slides perfectly

Attention: It is compulsory to make the installation of the stop-blocks (opening and closing) before placing and connecting the control panel, in order to perform a safe system.

2.2 INSTAL THE BASEPLATE

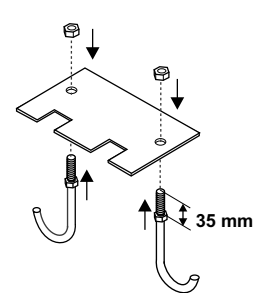
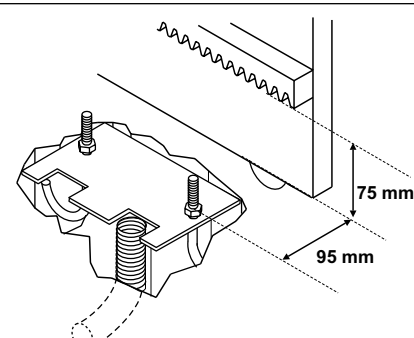
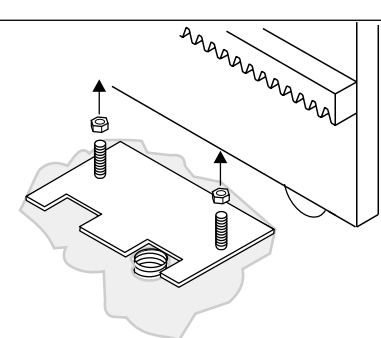
2.2A

- **Screw the nuts to the bolts until 35mm**
- Insert the bolts through the holes of the baseplate
- Screw two other nuts to the bolts, but do not tighten them

2.2B

- Make a hole on the ground where the baseplate and the flexible holes for wire passing will be installed
- Position the baseplate and fix it in a horizontal position

2.2C

- Anchor the baseplate with concrete, be careful to keep it clean
- Wait until the concrete is hard and take away the two nuts

ATTENTION: If the motor is installed where there is a danger of flooding, the baseplate will be installed higher than the water level.

2.3 OPENING OF THE MOTOR

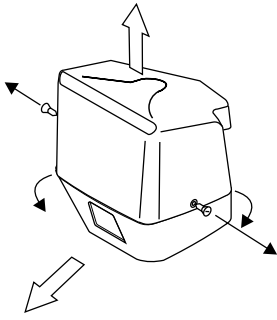

- Unscrew the screws
- Take away the top cover of the motor
- Take away the inferior plastic covering

2.4 POSITIONING OF THE MOTOR

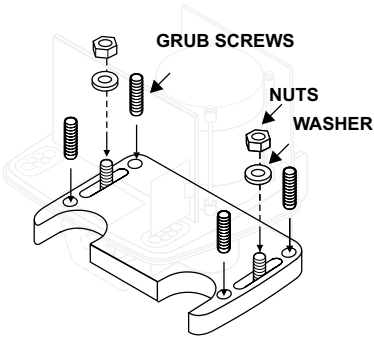

2.4 A

- Screw the 4 grub screws on their holes
- Position the motor on the baseplate, passing the bolts through the holes on the base
- Level the motor, adjusting the grub screws
- Insert the washers on the bolts and screws them not so much. They will be tighten after having placed the toothrack

2.4 B

- For the passage of the cables through the rubber cable gasket make very little holes so that the rubber gasket cable adhere well to each cable. **In opposite case insects can entry and cause short circuits damaging the control panel irreparably**

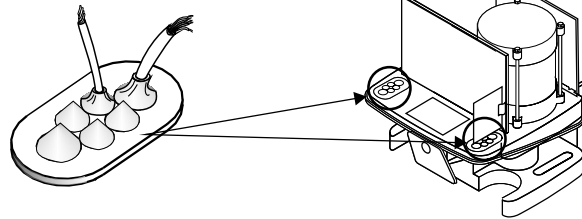
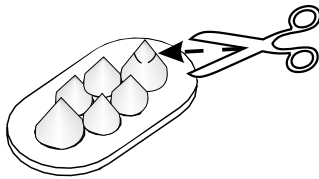

2.5 MOTOR UNLOCKING SYSTEM

- Insert the unlocking key on the front of the motor and turn it of 180° anticlockwise
- Push the unlocking device down until the clack

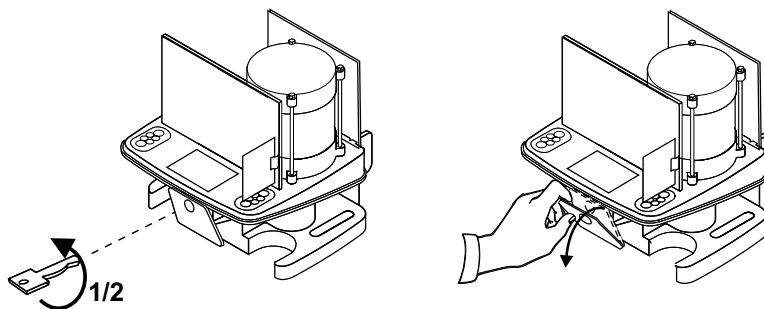

2.6 TOOTHTRACK INSTALLATION

2.6 A



ATTENTION: check that all the pinion surface is over the toothtrack

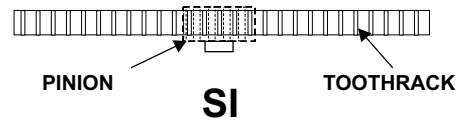
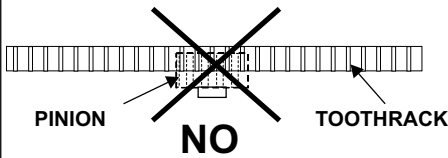

ONLY FOR MERCURIO 300 INSTALLATION WITH PLASTIC TOOTHTRACK M/16

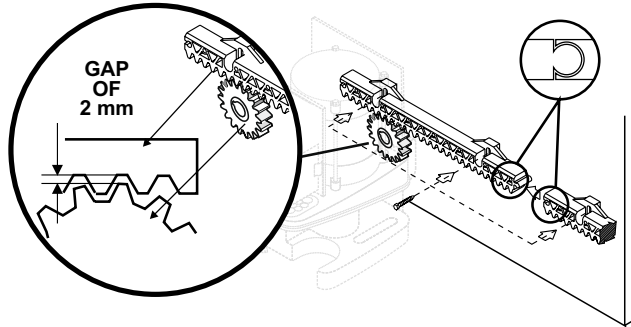

2.6 B

- Fix together the toothtracks (pieces of 340mm long), until to cover the run “gate+motor+plates”. Fix them with screws M6 - not supplied -
- When finished, adjust the distance between pinion and toothtrack, in this way there will be a constant gap of 2mm.

INSTALLATION OF THE STEEL TOOTH RACK M/14

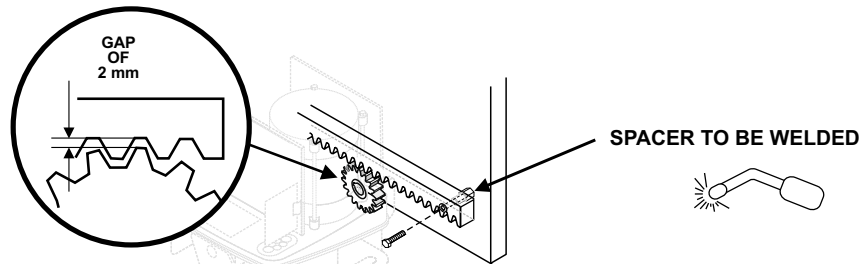

2.6 C

- Draw up the toothtracks 1m long until to cover the run “gate+motor+plates”
- Weld the spacers supplied with the toothrack, to the holes on the gate
- Fix the toothrack to the spacers and block it with the supplied nuts
- When finished, adjust the distance between pinion and toothrack, in this way there will be a constant gap of 2mm.

INSTALLATION OF THE STEEL TOOTHTRACK M/01

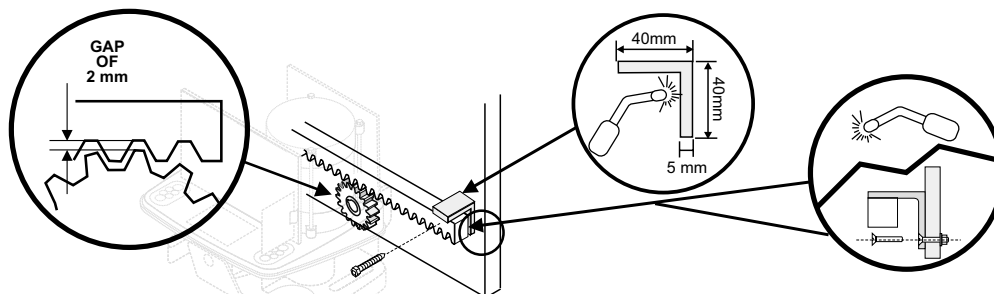

2.6 D

- Draw up the toothtracks 2m long until to cover the run “gate+motor+plates”
- Weld the toothtrack to an angle iron of 40x40x5mm dimensions
- Fix the angle iron to the gate with screws or weld it
- When finished, check that between pinion and toothtrack there is a constant gap of 2mm

2.7 LIMIT SWITCH INSTALLATION

2.7A POSITIONING

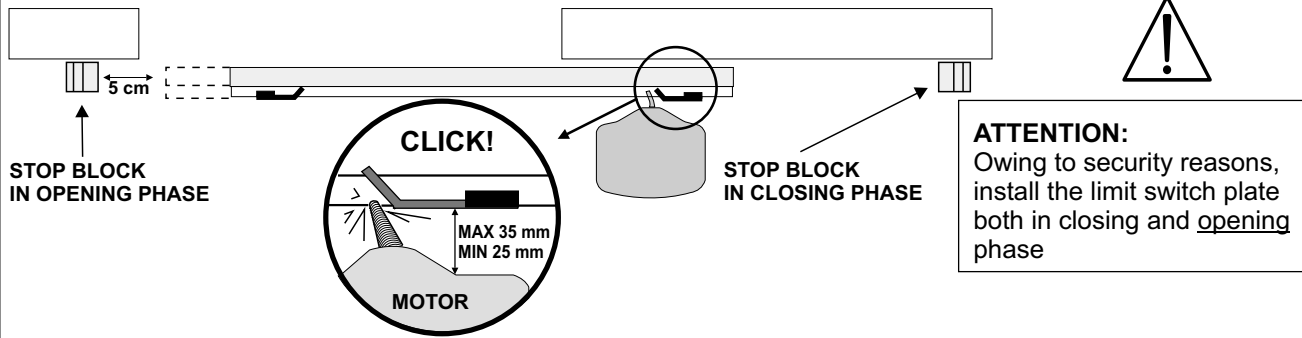

- Slide the gate in closing phase until it reaches 5 cm before the stop blocks.
- Position the plate so that it commands the dipswitch actioning spring, when the plate passes you hear the "click" of the dipswitch



ATTENTION:

- For the correct functioning of the limit switch system, respect a distance between motor and plate of 30 mm with a tolerance of ± 5 mm. Distances more than 5 mm could cause the blockage in opening or closing position of the gate. Distances less than 5 mm could cause the breaking of the limit switch command spring.
- The limit switch plates should be adjusted in such a way that, considering the inertia and temperature variations, the gate doesn't touch the stop blocks during opening and closing phase. Otherwise, during unlocking operation, the small door on the motor could break. We recommend you to check the condition both in summer and in winter, owing to seasonal thermic expansion.

2.7B FIXING

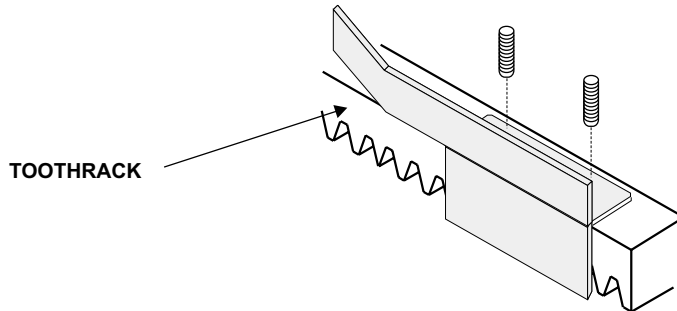

- When the correct position will be located, fix the plate on the tooth-rack with two grub screws M6 supplied

2.7C

- Repeat the procedure also in opening phase

2.8 FINAL FIXING OF THE MOTOR

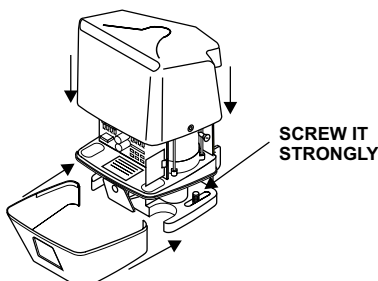

2.8 A

- Screw strongly the nuts on the bolts
- Reinstall the inferior plastic cover and the carter screwing it with two side screws

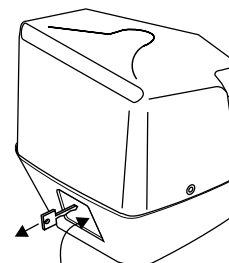

2.8 B

- Block the motor, closing the unlocking small door and remove the key

2.8 C

- Move the gate for some centimeters in opening or closing phase until the pinion's blockage

PART 3: ELECTRONIC CONTROL PANEL

3.1 TECHNICAL DATA AND ELECTRICAL CONNECTION CR/34 (MERCURIO 300-500)

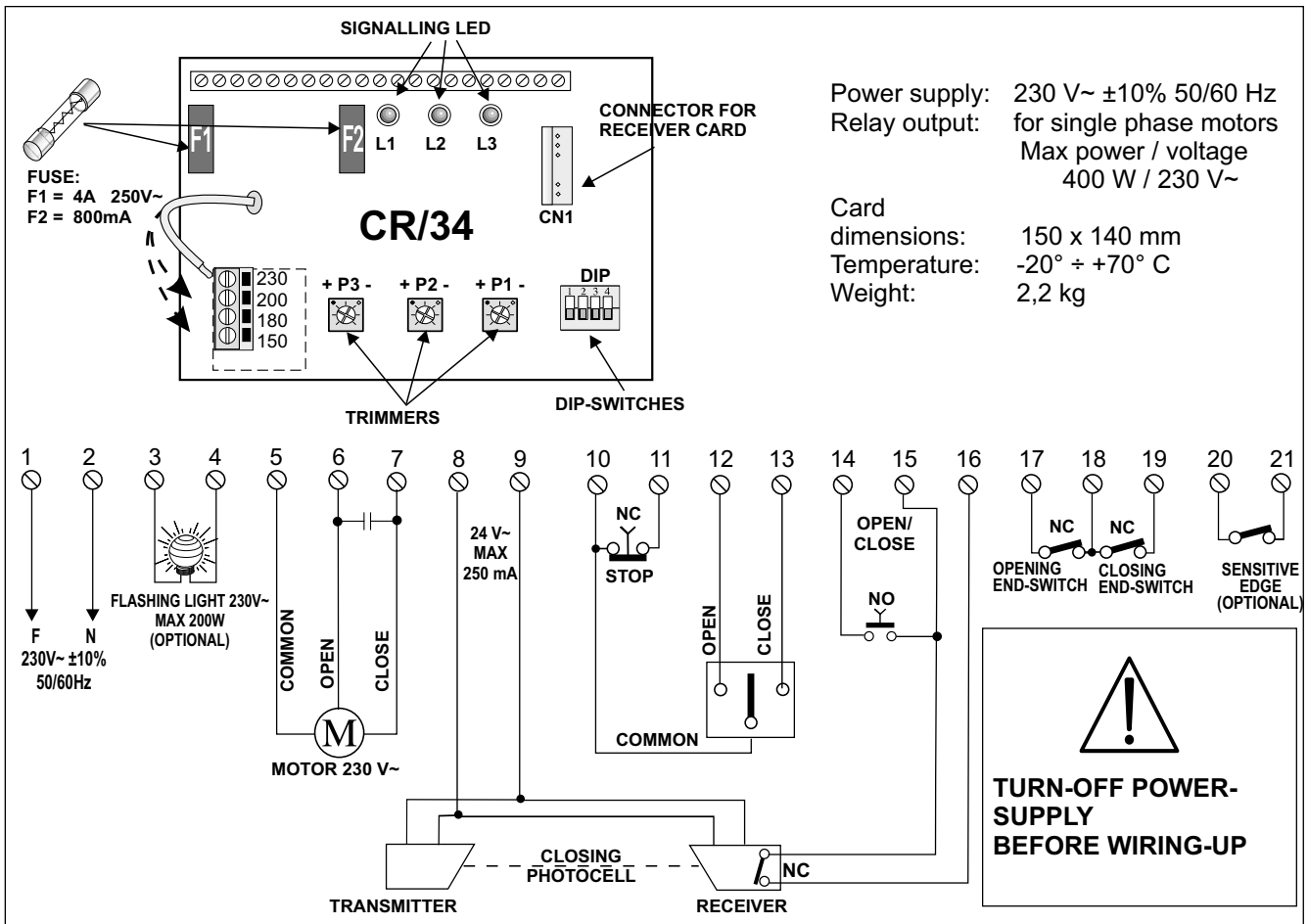

3.2 TECHNICAL DATA AND ELECTRICAL CONNECTION CR/34C (MERCURIO 800)

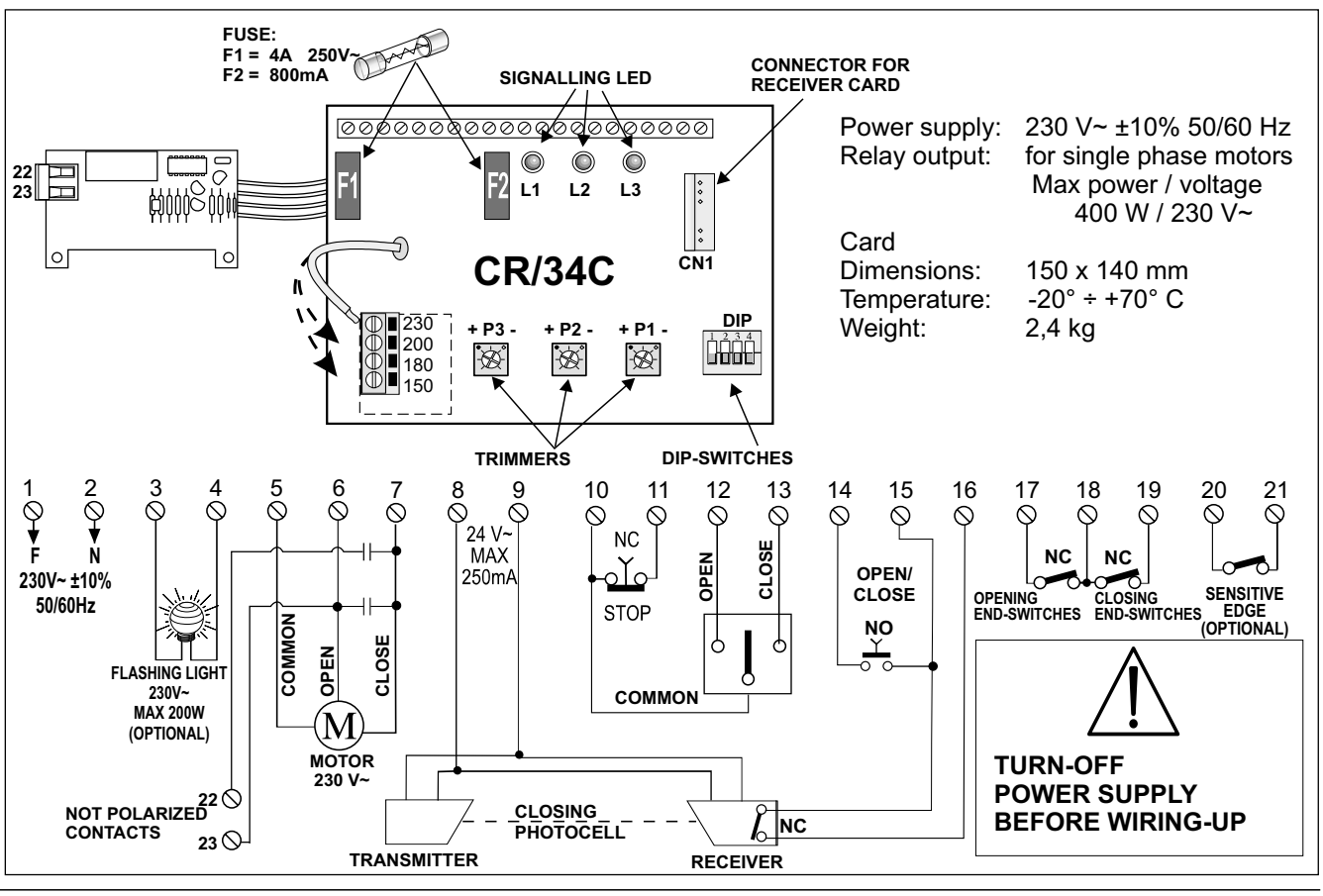

MERCURIO/300-500-800

3.3 GROUND CONNECTION

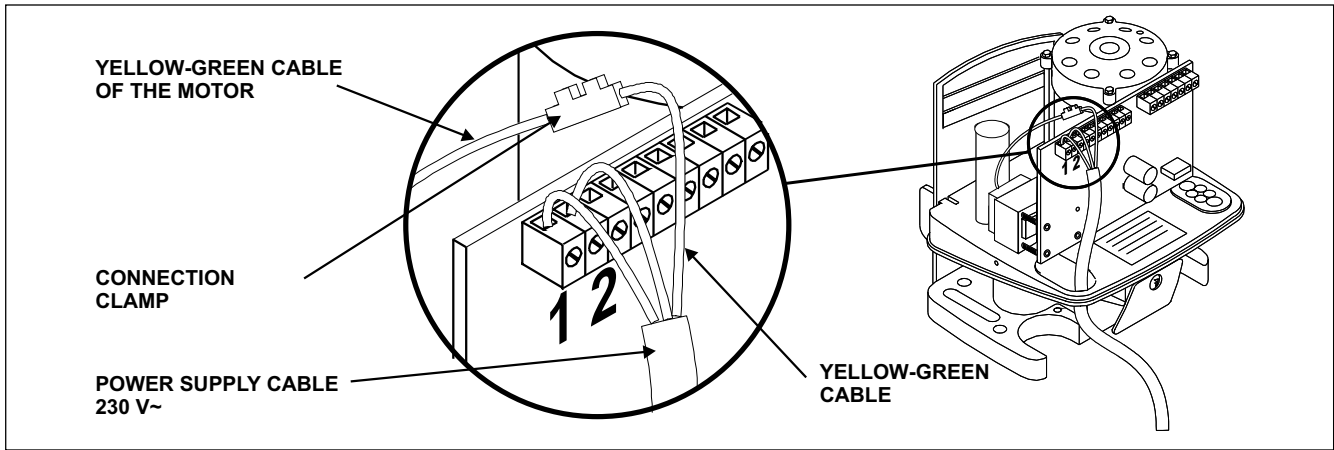

3.4 MOTOR CONNECTION

Connections are different if the motor (seen from inside) is positioned on the right side (standard configuration) or left side.

RIGHT SIDE MOTOR (STANDARD CONFIGURATION)

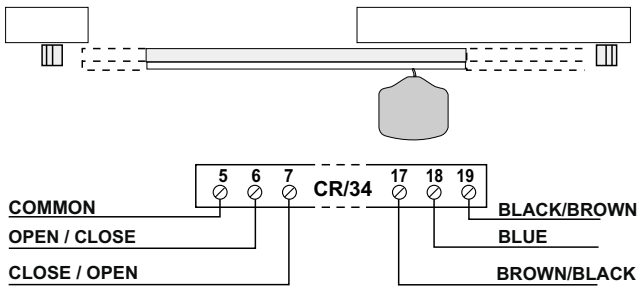

LEFT SIDE MOTOR

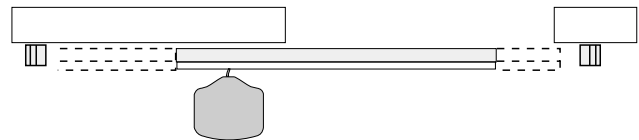

To connect the motor on the left side of the gate, invert the following connections:
6 with 7
17 with 19

3.5 ADJUSTMENT OF THE MOTOR POWER



The adjustment of the motor power can be made through an auto-transformer on the electronic control panel. It allows to choose the proper voltage of the motors. The installation must be made respecting the normatives for gate-automation systems.

ATTENTION
Big differences of temperature between summer and winter cause expansion on all materials, also on the material of our motor. We suggest you to adjust the motor power at the beginning of winter and summer.



3.6 TRIMMERS' FUNCTION

P1		1 ÷ 10 s	Warning time of the flashing light before the gate movement. The gate will start to move a decided time after the blink of flashing light.
P2		5 ÷ 180 s	Safety time: max time of motor power supply
P3		6 ÷ 155 s	Pause with opened gate: pause time with "opened gate" only if the automatic closing has been set

3.7 NORMAL FUNCTIONING SETTING

FUNCTIONING	DIP-SWITCH SETTING	FUNCTIONING DESCRIPTION
AUTOMATIC		<ul style="list-style-type: none"> - After opening impulse the gate opens, it remains opened for the decided time, and after it closes automatically. - During the opening phase, photocell interruption or a new impulse do not have any effect. - During closing phase, photocell interruption or an opening impulse causes the blockage of the gate for 2 seconds and then it opens again. - The gate will close automatically after the decided time.
SEMI-AUTOMATIC		<ul style="list-style-type: none"> - After opening impulse the gate opens and it remains opened until the following closing impulse. - During the opening phase, photocell interruption or a new impulse do not have any effect. - During closing phase, photocell interruption or an opening impulse causes the blockage of the gate for 2 seconds and then it opens again. - The gate will close after the following closing impulse.

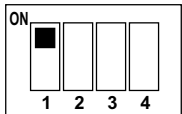
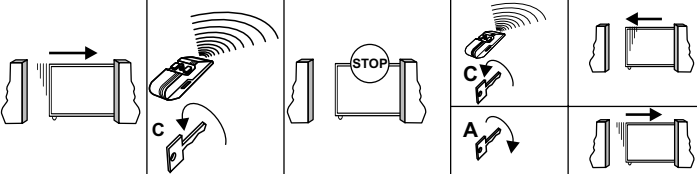
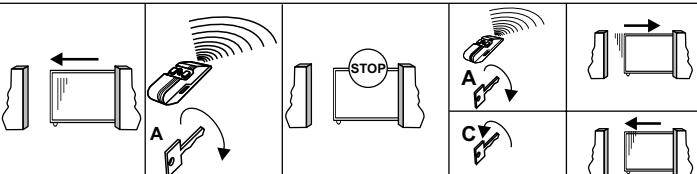
3.8 DIP-SWITCH SETTING

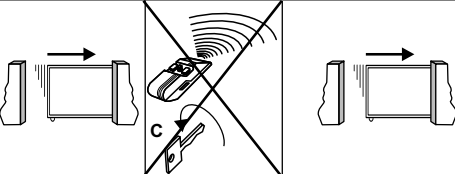
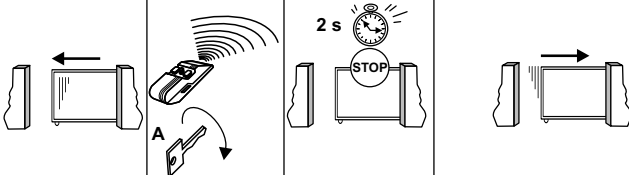
FUNCTIONING	DIP-SWITCH SETTING	FUNCTIONING DESCRIPTION
TRANSMISSION OF A IMPULSE DURING THE GATE MOVEMENT	 STEP BY STEP ACTIVATED FUNCTION	DURING OPENING PHASE <ul style="list-style-type: none"> - The transmission of a closing command during the opening phase, causes the gate blockage - The gate slides again to the indicated direction 
		DURING CLOSING PHASE <ul style="list-style-type: none"> - The transmission of an opening impulse during the closing phase, causes the gate blockage - The gate slides again to the indicated direction 
	 STEP-BY-STEP DEACTIVATED FUNCTION	DURING OPENING PHASE <ul style="list-style-type: none"> - The transmission of a closing impulse during opening is ignored 
		DURING CLOSING PHASE <ul style="list-style-type: none"> - The transmission of an opening impulse during the closing phase, causes the blockage for 2 sec. and the automatic re-opening. 

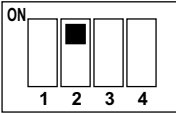
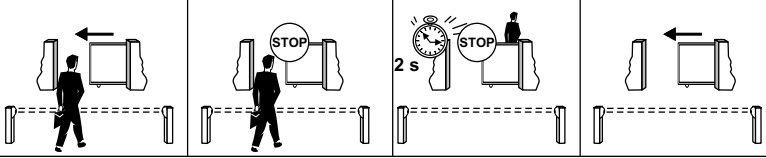
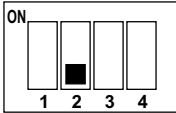
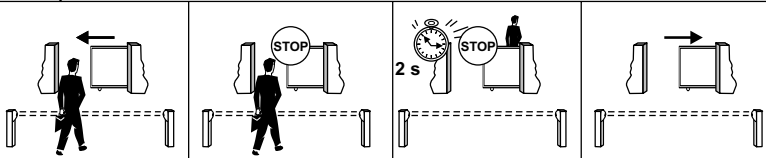
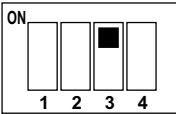
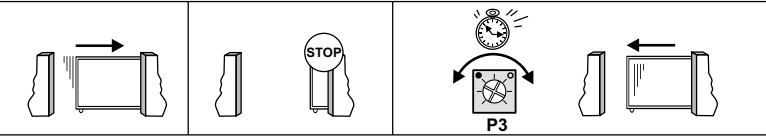
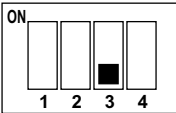
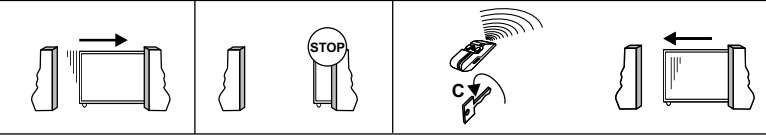
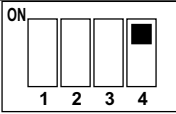
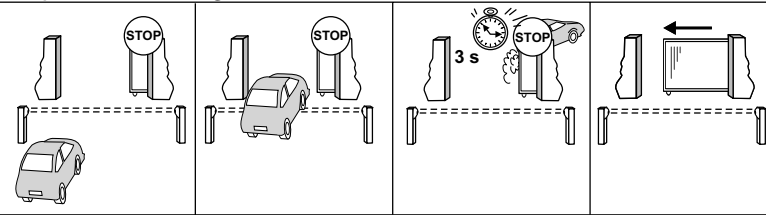
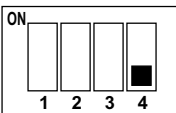
FUNCTIONING	DIP-SWITCH SET UP	FUNCTIONING DESCRIPTION
GATE REACTION WHEN CROSSING THE PHOTOCELLS BEAM		<ul style="list-style-type: none"> - When someone crosses the photocells during the closing phase, the gate stops, otherwise it is ignored - When the photocells beam is free, after 2 sec., the gate continues to close 
		<ul style="list-style-type: none"> - When someone crosses the photocells during the closing phase, the gate stops, otherwise it is ignored - When the photocells beam is free, after 2 sec., the gate starts to open 
AUTOMATIC OR BY HAND CLOSING OF THE GATE		<ul style="list-style-type: none"> - Automatic closing: after open gate pause, it closes automatically 
		<ul style="list-style-type: none"> - Closing by hand: the gate is opened until new impulse 
AUTOMATIC GATE CLOSING AT FIRST PHOTOCELLS CROSS		<ul style="list-style-type: none"> - When the gate is opened: after 3sec. from passing the photocells, the gate closes. 
		<ul style="list-style-type: none"> - The automatic closing function at first photocells crossing is deactivated

3.9 LED SIGNALLING

LED	FUNCTION
LED 1: Stop circuit	ON: closed contact -NC-
	OFF: open contact -NO-
LED 2: limit-switch opening circuit	ON: closed contact -NC-
	OFF: open contact -NO-
LED 3: limit-switch closing circuit	ON: closed contact -NC-
	OFF: open contact -NO-

PART 4: CARD RECEIVER SOG/4

4.1 CARD RECEIVER INSTALLATION

The card receiver SOG/4 has two channels:

- The first one is automatically assigned to the control panel (opening / closing phase)
- The second one is available for auxiliary command for the user, it can be set in two ways:
 - monostable (contact with impulse) for example to drive electrical locks, counterweight garage door, shutters.
 - bistable (permanent contact) for example to command an auxiliary relay for lighting.



ATTENTION:

before using each transmitter, it is necessary to memorize it on the card receiver (see 4.2).

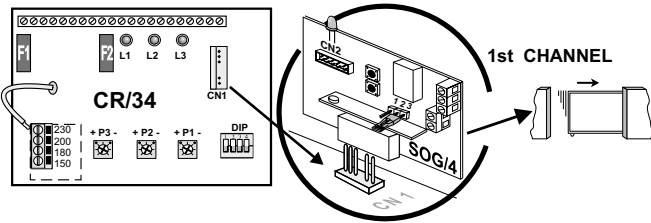

4.1A

- Insert the card receiver SOG/4 into the connector CN1 on the control panel. The first channel is automatically assigned to the control panel (opening / closing phase)

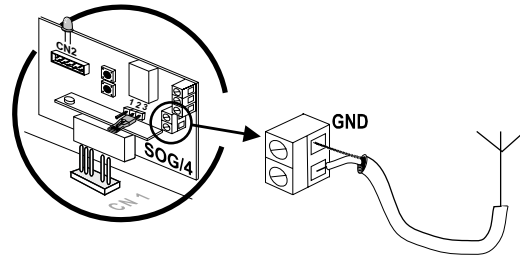

4.1B

- Connect the antenna using the 2 pole clamp.

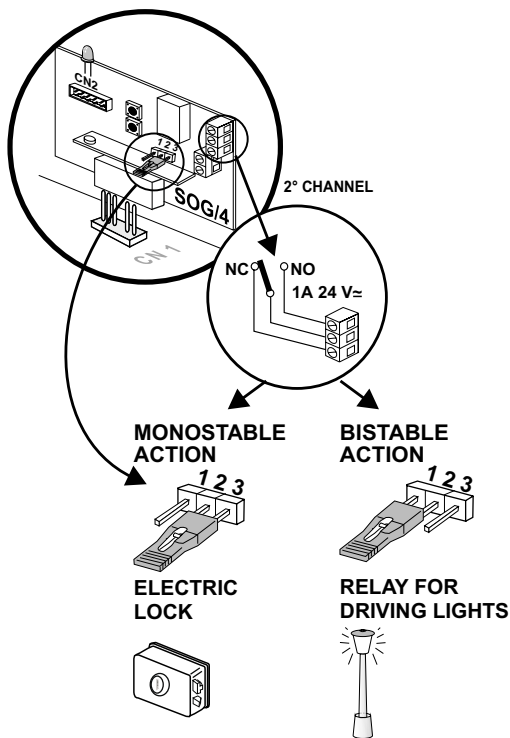

4.1C

- For the optional utilisation of the second channel, use a 3 pole clamp.
- The choice of the monostable action (contact with impuls) ex. electrical locking command or bistable (permanent contact) ex. light command happens through the jumper moving.



ATTENTION:

The relay for light drive should be chosen according to the application.

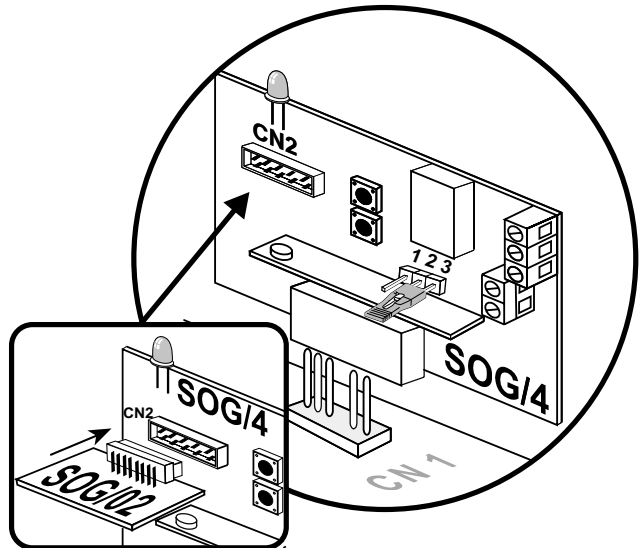

4.1D

- The card receiver SOG/4 memorizes up to 15 transmitters, expandable up to 783, using the optional card SOG/2.

MERCURIO/300-500-800

4.2 TRANSMITTER MEMORIZATION ON THE RECEIVER CARD

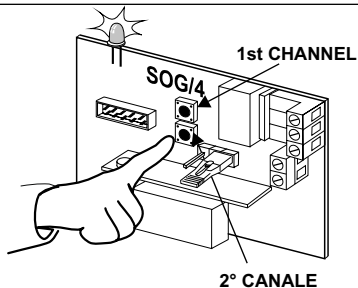

4.2 A

- Keep the button of the chosen channel for 0,5 sec. pressed, the led will flash 4 times and then it will remain fix.



ATTENTION:

Do not keep the button for 2 sec. or more pressed: the already stored codes will be erased

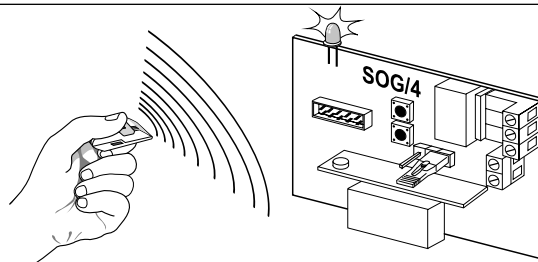

4.2 B

- Press the transmitter in order to send the signal, the led will flash 5 times and then it will remain fix
- Repeat the operation described above for storing other transmitters

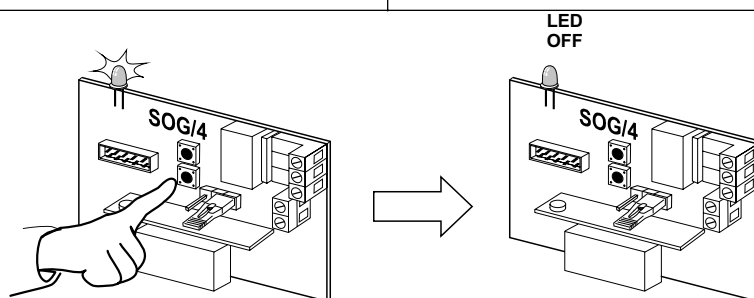

4.2 C

- Keep the button on the receiver for 0,5 sec. Pressed, in order to exit from the programming or wait 5 minutes: the red led has to switch off



ATTENTION:

When the number of available codes per channel - 15 or 783 - is exhausted the receiver exit automatically from the programming (see 4.1 D)

4.3 PROGRAMMED TRANSMITTER RESET

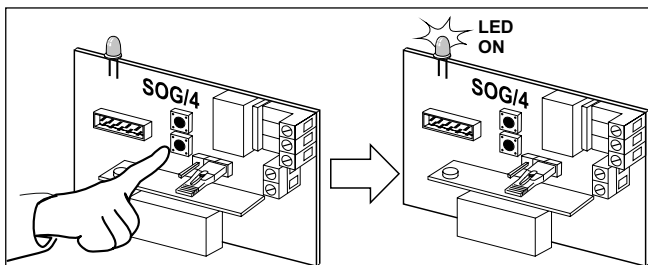

4.3 A

- If you want to reset the programming of all the transmitters, keep the button of the relevant channel for 2 sec. Pressed. The red led will light up fix.



ATTENTION:

It is not possible to reset only one transmitter

4.3 B

- If you want to add new transmitters, repeat the operations from point 4.2B or exit as indicated in point 4.2C



ATTENTION: In order to drive the electronic switching of the relay you have to keep the button of the transmitters for more than half second pressed. On the contrary the red led on the card switches on but the relay does not commutate

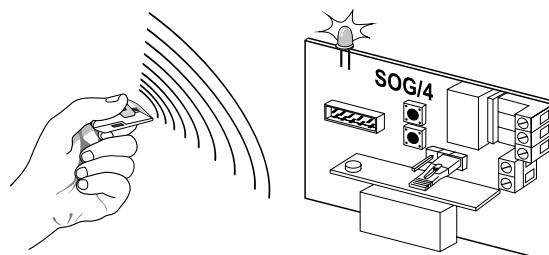

PART 5: PHOTOCELLS P/10

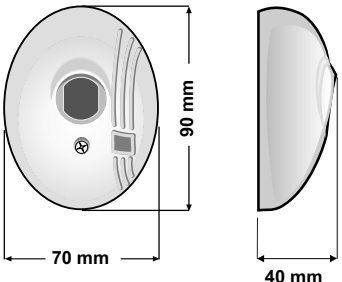

5.1 TECHNICAL DATA

	Power supply	24 V~ ±10%
	Relay output	1A 24 V~
	Action range	outdoor - 10 m indoor 20 m
	Absorption TX	. 55 mA at 24 V-; 67 mA at 24 V~
	Absorption RX	. 15 mA at 24 V-; 25 mA at 24 V~
	Temperature -10° ÷ +60°C
	Dimensions 70 x 40 x 90 mm
	Weight 120 g

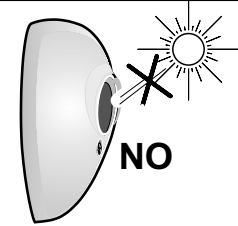
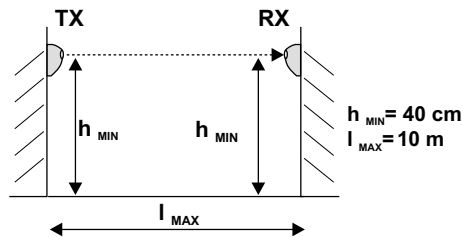
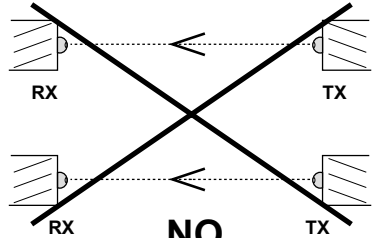
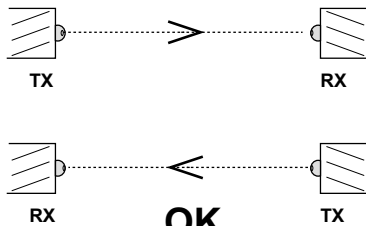
5.2 INSTALLATION POSITION

 <p>5.2 A</p> <ul style="list-style-type: none"> The receiver must not be directly exposed to the sun light 	 <p>5.2 B</p> <ul style="list-style-type: none"> They have to be positioned at 50 cm from the ground
 <p>5.2 C</p> <ul style="list-style-type: none"> If 2 couple of photocells are installed, position the transmitters on the opposite side one from the other 	

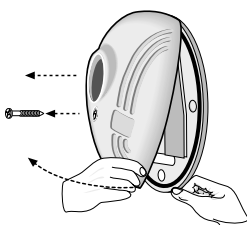
5.3 INSTALLATION

 <p>5.3 A</p> <ul style="list-style-type: none"> Open the photocell, unscrewing the screw on the front and pull the small tab 	 <p>5.3 B</p> <ul style="list-style-type: none"> Make a hole on the bottom of the device <p>ATTENTION The hole for the cable entry has to be made with dimensions suited to the entry of one cable only, in order to avoid bugs introduction</p> 
--	--

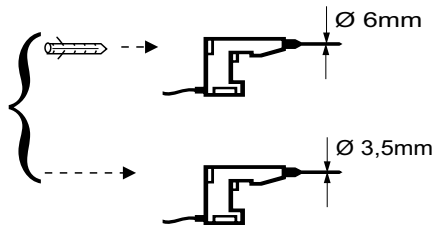

5.3 B

- Make on the fixing wall the holes using the templates supplied, dimensions:
 - Ø 6 mm for wall installation with supplied plugs.
 - Ø 3,5 mm for installation on metal support with supplied screw
- Fix the bottom of the photocells on the wall

POSITION OF THE CONTACT WHEN THE RECEIVER IS PICKED UP

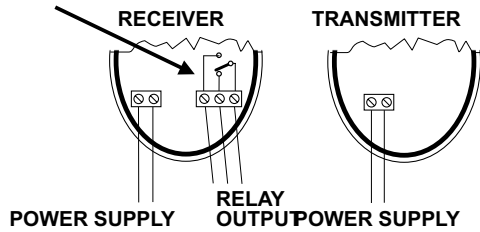

5.3 D

- Make the electrical connections
- Close the photocell

5.4 ALLIGNMENT CONTROL

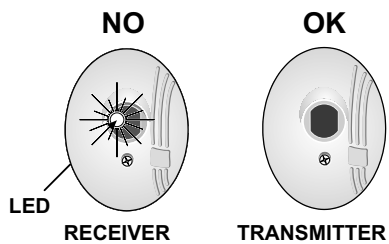

- Verify the alignment of the photocells through the red led of the receiver

LED on: photocell not aligned or obstructed
LED off: photocell aligned

PART 6: TECHNICAL DATA OF THE MOTOR

	MERCURIO 300	MERCURIO 500	MERCURIO 800
Model of the motor	MT/300	MT/500	MT/ 800
Type of the motor	self-locking	self-locking	self-locking
Max gate weight	300 Kg	500 Kg	800Kg
Power supply	230 V~ ±10% 50/60 Hz	230 V~ ±10% 50/60 Hz	230 V~ ±10% 50/60 Hz
Absorption	1,5A	2A	2,7A
Power	140 W	180 W	240W
Max thrust	530 N	760 N	880N
Adjustment of the motor power	By regulation of the input voltage	By regulation of the input voltage	by regulationof the input voltage
Gate spee	10/m/min	10/m/min	10/m/min
Service	50%	50%	50%
Motor thermal protection	+150 °C	+150 °C	+150 °C
Reduction ratio	1:28	1:28	1:28
Protection degree	IP43	IP43	IP43
Working temperature	-20 °C ÷ +60 °C	T-20 °C ÷ +60 °C	-20 °C ÷ +60 °C
Weight	9 Kg	9,6 Kg	9,6Kg
	216 x 272 x 248 mm	216 x 272 x 248 mm	216 x 272 x 248 mm

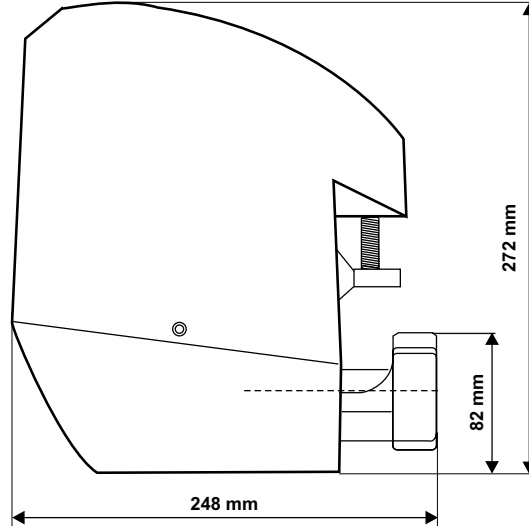
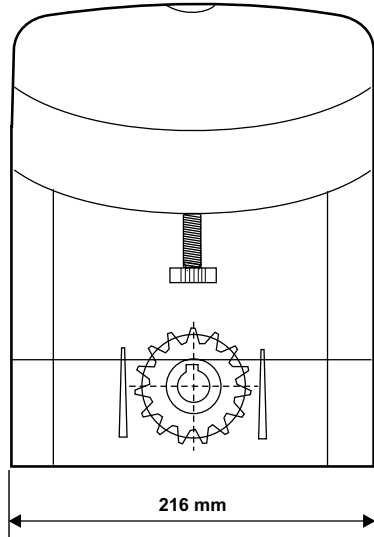

PART 7: MANUAL UNLOCKING GATE SYSTEM

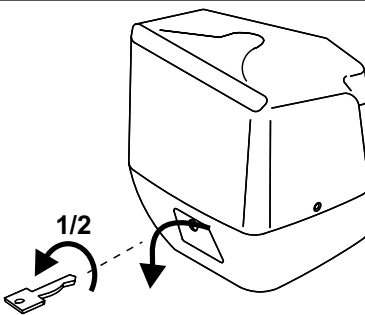

8.1 A

- Insert the key on the small door on the front of the motor and turn it of 180° anticlockwise
- Pull the small door down until the trip
- Now the gate can be moved by hand



ATTENTION:
THIS OPERATION OF UNLOCKING IS EASIER IF THE GATE DO NOT TOUCH THE MECHANICAL STOP BLOCKS.

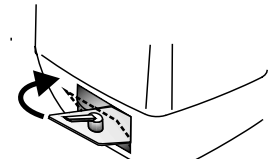

8.1 B

- To block the gate again push the small door up and take away the key
- Move the gate for some centimeters until the pinion is blocked

PART 8: PROBLEM GUIDE

PROBLEME	CAUSE	SOLUTION
The motor-reducer does not work	Power supply failure	<ul style="list-style-type: none"> • Check the presence of voltage at the power supply entry clamps to the motor • Check that the power supply cable is not cut off. The substitution of the cable has to be carried out by an authorized technician
	Faulty fuse	<ul style="list-style-type: none"> • Replace the fuse
	The motor over-heats	<ul style="list-style-type: none"> • Stop the motor for 5 minutes and then try to make it work again
The gate does not complete its run	Gate blockage	<ul style="list-style-type: none"> • Unlock by hand the motor and move it to verify that there are no obstacles • Remove obstacles
	Not correct limit-switch set-up	<ul style="list-style-type: none"> • Check the position of the limit-switch slide plates and their working on the spring for the micro-switch drive, adjust them
	Not proper position of the motor-reducer	<ul style="list-style-type: none"> • Check that the distance between limit-switch and spring is 25 ÷ 35 mm.
The gate does not move or the motor slips	Motor power thrust not properly set	<ul style="list-style-type: none"> • Turn-off power-supply and set the motor power
The gate has difficulty in starting	Exhausted condensers	<ul style="list-style-type: none"> • Measure the condensers capacity and in case they are exhausted, replace them
The gate is blocked against the mechanical stop block	Limit-switch plate adjustment not correct	<ul style="list-style-type: none"> • Take away the inferior plastic part of the motor casing • Unscrew the fixing nuts on the bolts of the plate • Take away the motor from its position by detaching the pinion from the toothrack • Move the gate by hand, far from the mechanical stop-blocks • Unlock the motor • Position the motor on the plate • Adjust properly the limit-switch plates • Reinstall the inferior part of the motor and lock it again

The Company reserves the right to modify the device without advance notice. The standard guarantee given by SERAI is valid 18 months - excepting when differently agreed - from the date of the fiscal invoice which proves the relevant purchasing and it is performed by SERAI on the head office of Legnaro-Padova. The freights of transport are at customer's charge



MERCURIO/300-500-800



VIA ENRICO FERMI, 22
35020 LEGNARO - PADOVA
I T A L I A

TEL INTERNATIONAL ++39 049 79 08 58
FAX INTERNATIONAL ++39 049 883 05 29
E-MAIL: export@serai.com
SITO WEB: www.serai.com