



SEA[®]
Sistemi Elettronici
di Apertura Porte e Cancelli
International registered trademark n. 804888



English

GATE 1 DG R2BF

CONTROL UNIT FOR SLIDING GATES, SWING GATES, BARRIERS AND GARAGE DOORS

(Cod. 23001158)

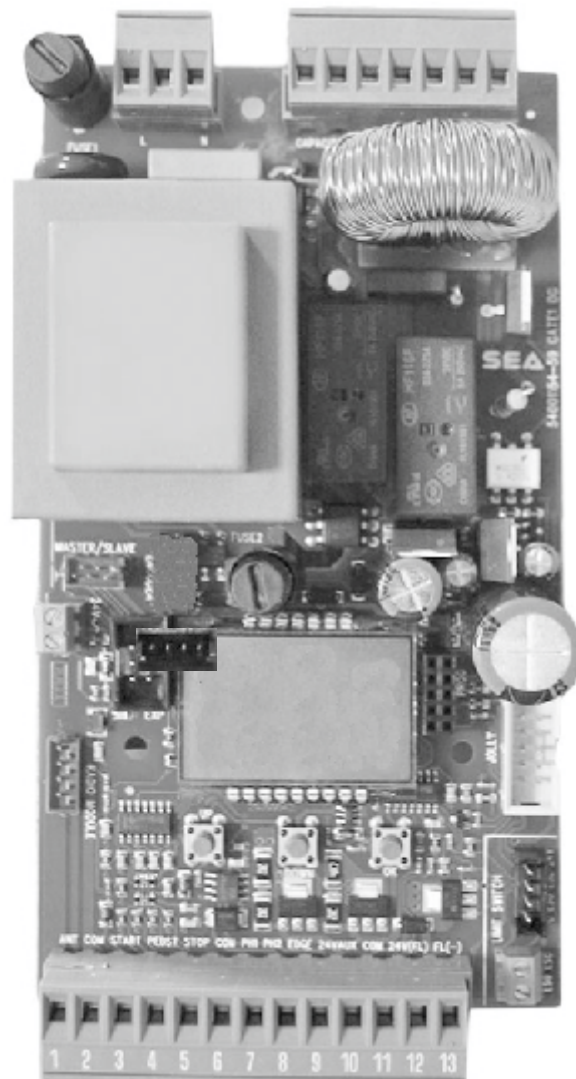

SEA S.p.A.
Zona industriale 64020 S.ATTO Teramo - (ITALY)
Tel. +39 0861 588341 r.a. Fax +39 0861 588344

www.seateam.com

seacom@seateam.com

COMPONENTS

TECHNICAL SPECIFICATIONS

Control unit power supply: 230 Vac 50/60 Hz - 115Vac 50/60 Hz

Absorption in stand by: 30 mA

Environment temperature : -20°C ∇ +50°C ∇

Specifications of external enclosure: 183 X 238 X 120 - Ip55

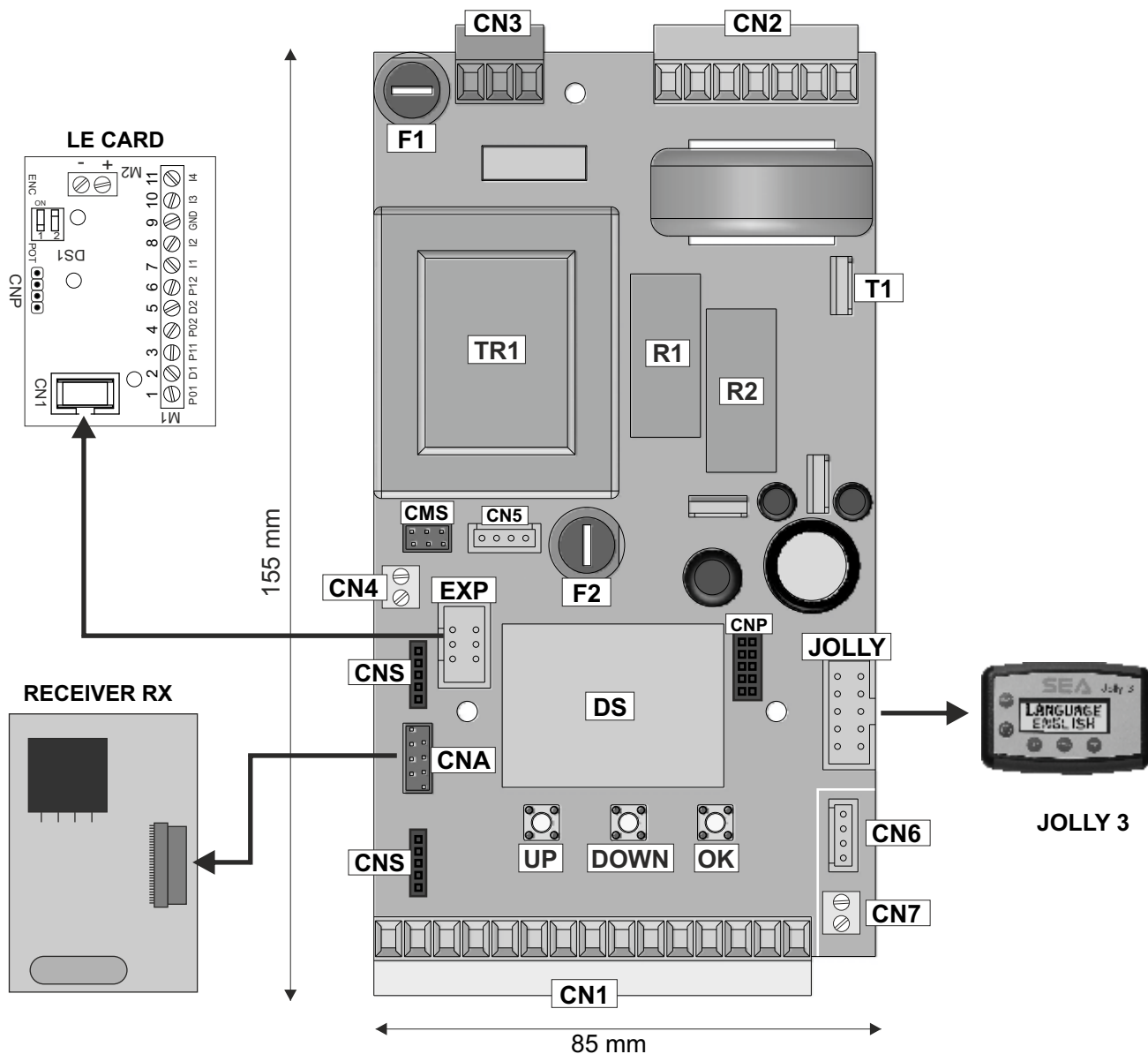

CN1 = Input/output connectors

Cn2 = Motor - capacitors - courtesy light connector

CN3 = Power connector

CN4 = 24V~ connector

CN5 = Encoder connector

CN6 = Pre-wired limit switch connector

CN7= Limit switch connector not pre-wired

CNA = RX Receiver connector

CNP = Porgraming connector

CNS = RF FIX Receiver connector

EXP = Expansion module connector/LE Card

JOLLY = Jolly 3 connector

DS = Programming display

CMS = MASTER/SLAVE connector

OK = Programming button

DOWN = Programming button

UP = Programming button

T1 = Motor piloting Triac

R1 = Relay C motor command courtesy light

R2 = Relay motor exchange

F1 = 6.3AT fuse on 230V/10AT on 115V

F2 = Accessories 1A fuse

TR1 = Power transformer

CONNECTIONS

RADIO MODULE RF FIX (CNS)

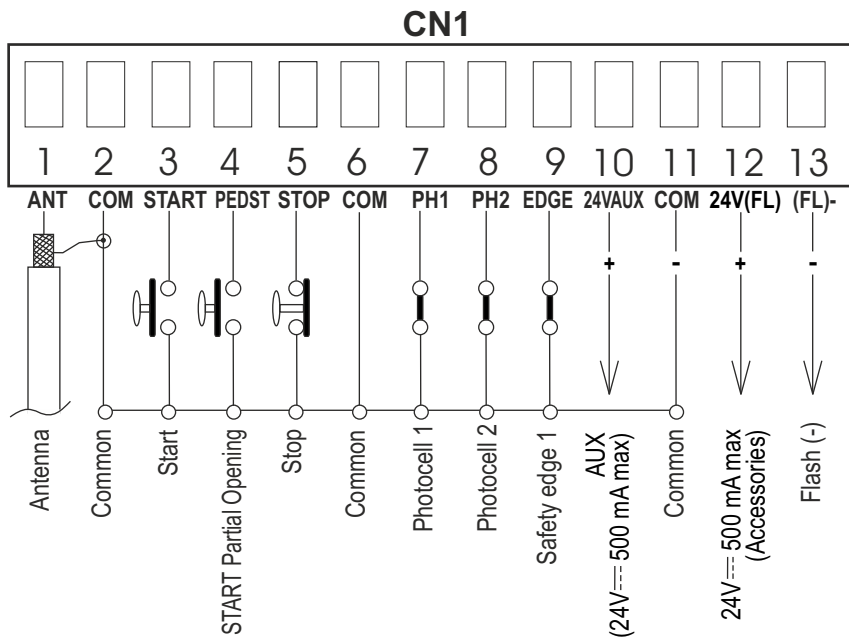
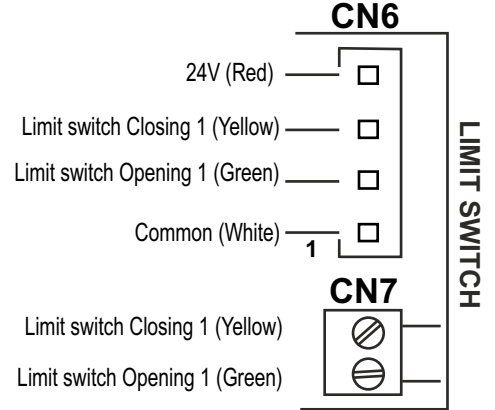
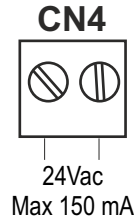
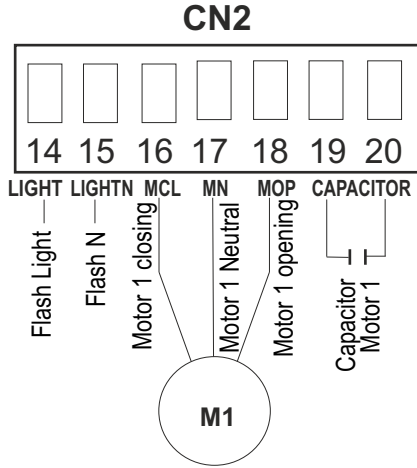
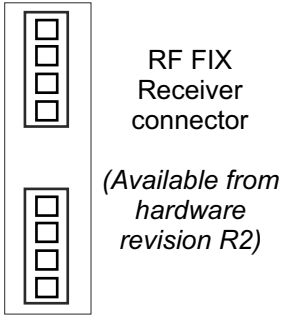

JUMPERS

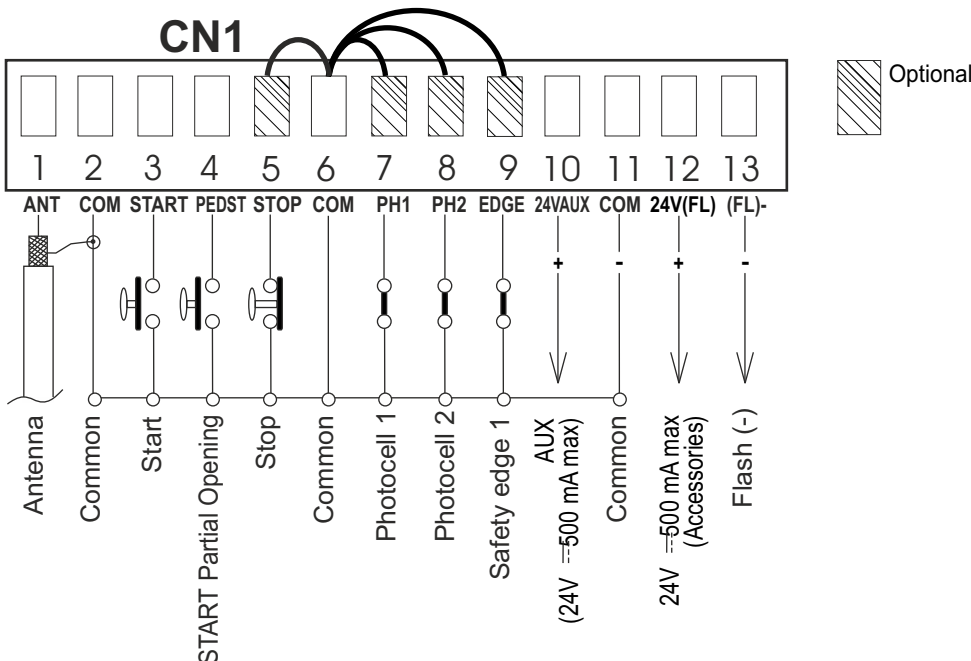

WARNING:
The control unit is designed with the automatic detection of not used N.C. inputs (Photocells, Stop and Limit switch) except the SAFETY EDGE input. The exclude inputs in self-programming can be restored in the "Check inputs" menu without need to repeat the programming

PROGRAMMING

FAST SELF-LEARNING

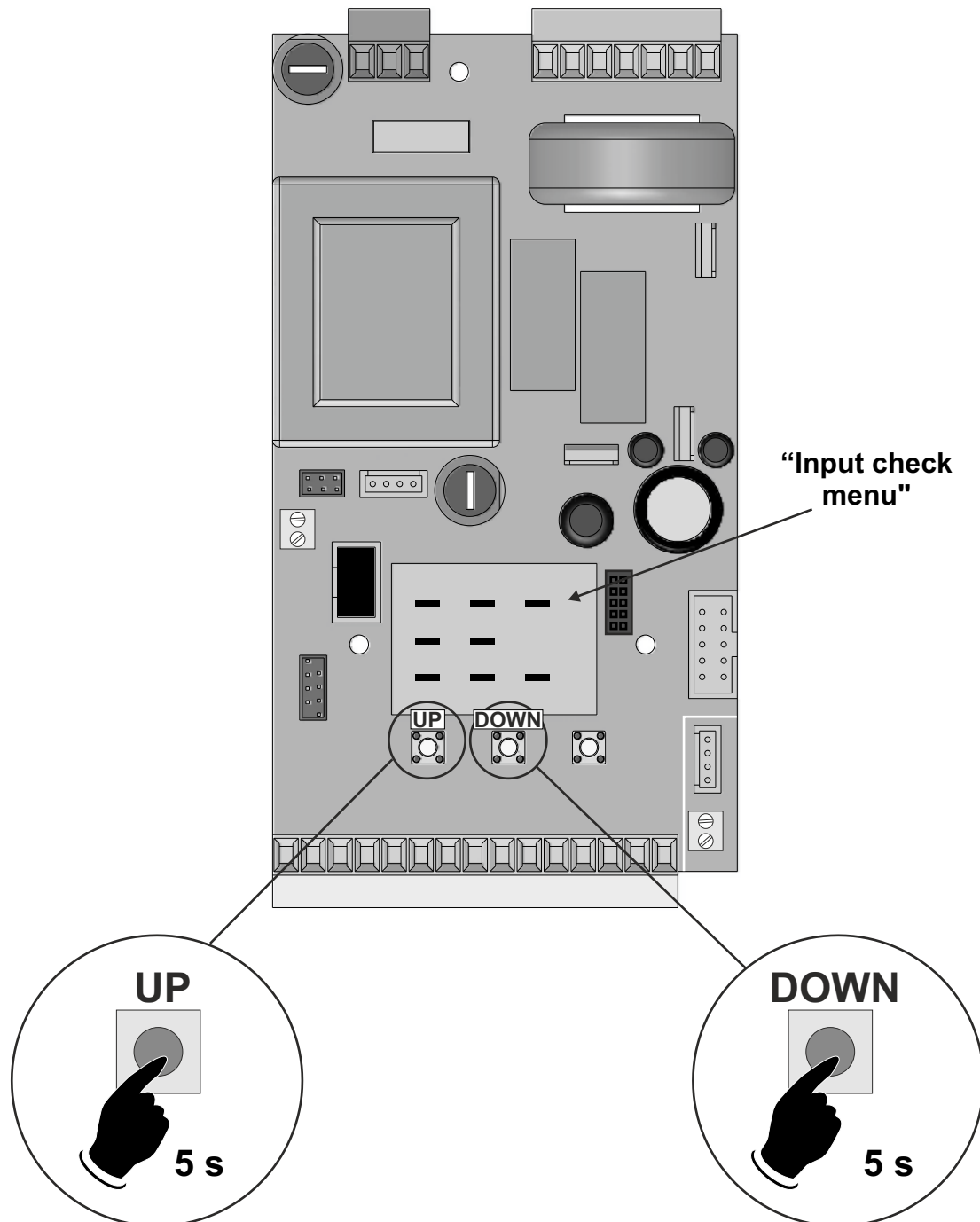

Start quick programming

You can start the quick programming by holding UP for 5 s in the "Input check menu", until the motor starts.

Fast self-learning START command by radio control

You can store the START button of the remote control while pressing DOWN for 5 s in the "Input check menu".

Once the writing "Press button" appears, press the button of the transmitter, which you want to store for the START command. By pressing OK, you can exit the menu, otherwise it will be left automatically after 5 seconds.

PROGRAMMING QUICK START

PROGRAMMING BUTTONS

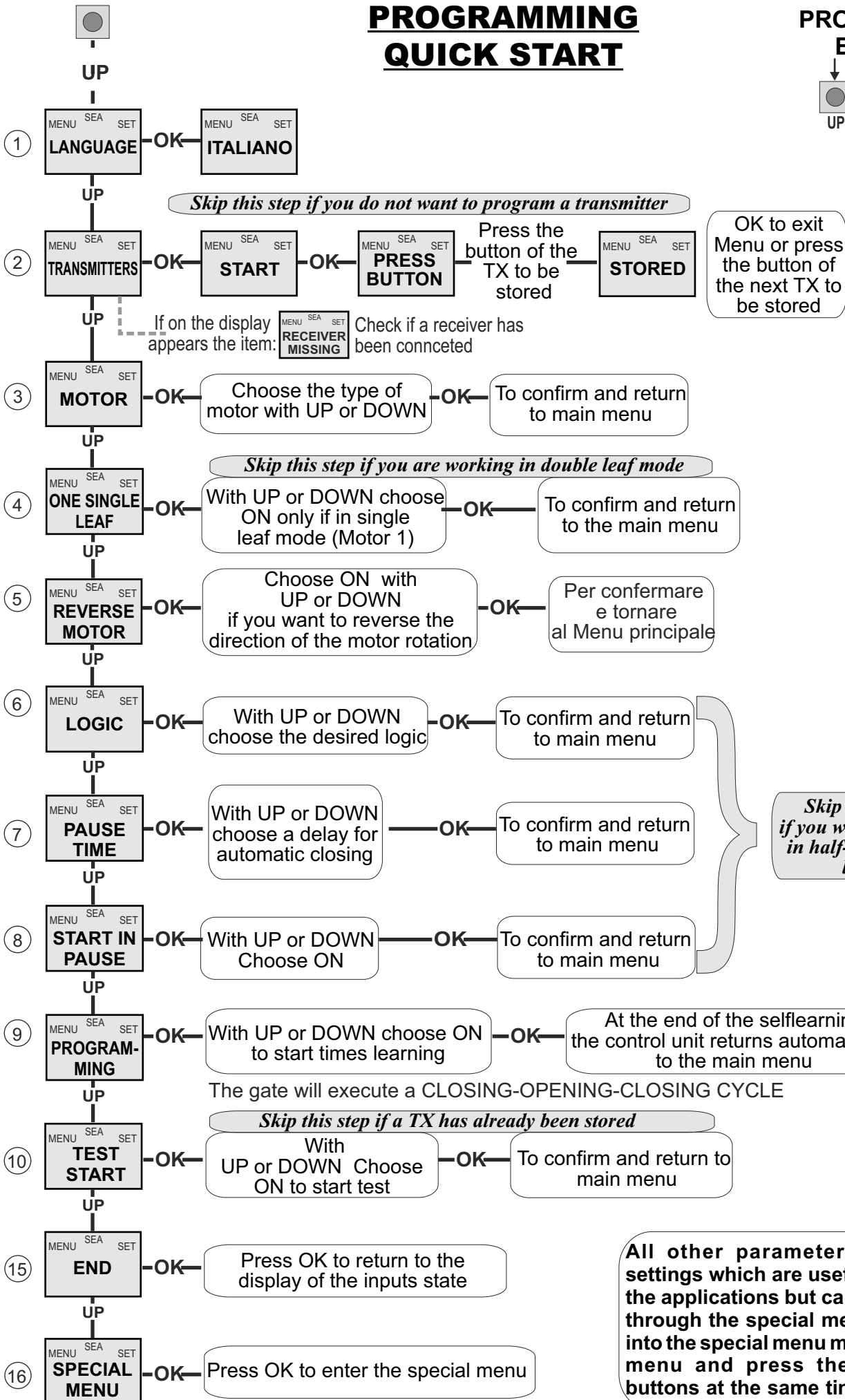
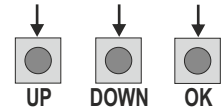

WORKING TIMES SELF LEARNING

The control unit is pre-set with the default settings, to start the control unit with the DEFAULT settings just keep pressed the UP and DOWN buttons at the same time power supplying the control unit the display shows the message "Init". The DEFAULT settings are shown in the Menues table.

LEARNING WITH LIMIT SWITCH (WITH OR WITHOUT ENCODER)

When limit switches are mounted, the gate executes automatically the following cycle: CLOSING - OPENING - CLOSING. Before starting the learning, make sure (through the test menu), that the relative limit switches of every opening are employed.

WORKING TIMES SELFLEARNING THROUGH IMPULSES

ATTENTION: This procedure is potentially dangerous and should only be performed by qualified people in safety conditions.

NOTE: The card is preset with the standard working times, therefore the automation can be started even without the times programming, simply by adjusting the timing on the display (see default times).

- 1) Turn off electricity, release the motors and manually position the leaves on halfway.
Reset the mechanical lock.
- 2) Connect the control board to the power supply
- 3) Select on the on-board display or JOLLY3 programmer, the type of motor that you are using as indicated in the display management.
- 4) If necessary also set the operation logic and the other parameters. If you want to program with a transmitter, store a transmitter before programming.
- 5) Select 9-PROGRAMMING on the display, press OK and than one of the UP or DOWN buttons.
(If the motor starts in opening, remove and re-put power supply, select on the display 5-REVERSE MOTOR. And through the UP and DOWN button put it on ON, or if you have the Jolly3 programmer, activate the motor exchange function.)
- 6) At this point the gate will start the following cycle: CLOSING - OPENING - CLOSING.
During cycle, to store the respective stops, press UP or DOWN or START at every point of stop of the leaf.
- 7) The self-learning is done.

SELFLEARNING OPERATION TIME WITH ENCODER / POTENTIOMETER

When an encoder is installed, it is necessary to select "On" in the 32-ENCODER menu, when the potentiometer is installed, it is necessary to select "Potentiometer" in the 32-ENCODER menu. Start programming and make sure that leaf starts as first in closing. With Encoder ON, the gate will automatically execute the following cycle: CLOSING - OPENING - CLOSING. With potentiometer, the gate will automatically execute the following cycle: CLOSE - OPENING - CLOSE - OPENING and CLOSING with SLOW-DOWN.

Note 1: For stop detection sensitivity setting refer to the special menu.

Note 2: With the potentiometer you can also make the learning giving impulses as described under point 6 of the preceding paragraph. In this case it is also possible to modify the parameters I.AP.M1 and I.CH.M1 of + 100 impulses, if you need to optimize the initial and the final position.

SELFLEARNING OPERATION TIME WITH AMPEROMETRIC SENSOR

(For electromechanical motors only)

The times learning can be done only on electromechanical gates, taking advantage of the automatic detection of the stops. Once the programming has been started just make sure that the gate executes the following cycle: CLOSING - OPENING - CLOSING.

Note: For stop detection sensitivity setting refer to the special menu.

FUNCTION LOGIC

AUTOMATIC LOGIC

A start impulse opens the gate. A second impulse during the opening will not be accepted. A start impulse during closing reverses the movement.

NOTE 1: To have the automatic closing it is necessary to set a pause time, otherwise all the logic will be semi-automatic.

NOTE2: It is possible to choose, whether to accept or not, the start in pause, selecting in the MENU the item 8-START IN PAUSE and choosing ON or OFF. By default, the parameter is OFF.

SECURITY LOGIC

A start impulse opens the gate. A second impulse during opening reverses the movement. A start impulse during closing reverses the movement.

NOTE 1: To have the automatic closing it is necessary to set a pause time, otherwise all the logic will be semi-automatic.

NOTE2: It is possible to choose, whether to accept or not, the start in pause, selecting in the MENU the item 8-START IN PAUSE and choosing ON or OFF. By default, the parameter is OFF.

STEP BY STEP TYPE 1 LOGIC

The start impulse follows the OPEN-STOP-CLOSE-STOP-OPEN logic.

NOTE 1: To have the automatic closing it is necessary to set a pause time, otherwise all the logic will be semi-automatic.

NOTE2: It is possible to choose, whether to accept or not, the start in pause, selecting in the MENU the item 8-START IN PAUSE and choosing ON or OFF. By default, the parameter is OFF.

STEP BY STEP TYPE 2 LOGIC

The start impulse follows the OPEN-STOP-CLOSE -OPEN logic.

NOTE 1: To have the automatic closing it is necessary to set a pause time, otherwise all the logic will be semi-automatic.

NOTE2: It is possible to choose, whether to accept or not, the start in pause, selecting in the MENU the item 8-START IN PAUSE and choosing ON or OFF. By default, the parameter is OFF.

DEAD MAN LOGIC

The gate opens as long as the **START** button of opening is pressed; releasing it the gate stops. The gate closes as long as the button connected to the **PEDESTRIAN START** is pressed; releasing it the gate stops. To execute complete opening and/or closing cycles the related pushbuttons must be constantly pressed.

2 PUSHBUTTONS LOGIC

One start opens, one pedestrian start closes. In opening the closing will not be accepted. In closing a start command reopens, a pedestrian start command (closes) will be ignored.

PASSWORD ENTERING MANAGEMENT

With a new control unit all menus can be displayed and set and the password will be disabled. Selecting one of the Menus and keeping UP and DOWN pressed at the same time for 5 seconds, you will access the SP Menu containing the 112-PASSWORD Submenu. Pressing OK in the 112-PASSWORD Menu, you will proceed with the entering of the numeric code of the 4-digit password. Use UP and DOWN to increase or decrease the number, press OK to confirm it and you will pass automatically to the entering of the next number. Pressing OK after the last entered number the word "Sure?" appears, confirm the activation of the password and the message OK appears, pressing UP or DOWN instead you can cancel the operation and "No operation" will appear on the display. Once entered the password, it will be definitively activated, once the display switch off timeout has expired, or by turning off and on again the control unit. Once the password has been activated, the menus of the display can be only displayed but not set. To unlock them you must enter the correct password in the 112-PASSWORD menu, if the password is wrong the message "Error" will appear. At this point, if the password has been entered correctly, the menus will be unlocked and it will be possible to change the parameters of the control unit again. If the control unit has been unlocked through 112-PASSWORD Menu, it is possible to enter a new and different password, using the same entering process as for the first one; at this point, the old password will no longer be valid. If the password has been forgotten, the only way to unlock the control unit is to contact the SEA technical assistance, which will assess whether to provide the procedure to unlock the control unit or not.

Note: The password cannot be set through the Jolly 3 terminal.

GATE 1 DG R2BF MENU FUNCTIONS TABLE

MENU		SET	DESCRIPTION	DEFAULT	SET VALUE
1	LANGUAGE	<i>Italiano</i>	Italian	English	
		<i>English</i>	English		
		<i>Français</i>	French		
		<i>Español</i>	Spanish		
		<i>Dutch</i>	Dutch		
2	TRANSMITTERS	<i>Start</i>	Start	Start	
		<i>Partial opening</i>	Partial opening		
		<i>External module</i>	External module		
		<i>Stop</i>	Stop	Partial Opening	
		<i>Unloch</i>	Storing of a command for unlocking the electric brake		
		<i>Delete a transmitter</i>	Delete single transmitter		
		<i>Clear memory</i>	Delete transmitter memory		
		<i>End</i>	"Transmitters" menu output		
		<i>Bistable Stop</i>	Pressed once, it stops the gate. Pressed twice, it reactivates the START input		
3	MOTOR	<i>Hydraulic</i>	230V hydraulic operators Mini/Half/Full/SuperFull Tank - Compact - SuperCompact - Ara - Joint - Scuti - Lyra - SuperLyra - Sprint - Vela - Vela Industrial - Tire Killer	Mechanic	
		<i>Sliding</i>	230V sliding operators Mercury - Saturn - Boxer - Lepus - Lepus Industrial - Lepus Box - Lepus Sectional		
		<i>Reversible sliding gate</i>	Reversible sliding gate operators Lepus Reversible - Lepus Industrial Reversible		
		<i>Magnetic sliding gate</i>	Sliding gate operators with magnetic limit-switch		
		<i>Three-phase - Bollards</i>	Operators with Three-phase Module : Lepus (Threephase - Industrial Threephase - Box Threephase - Sectional Threephase) - Big 4000. Bollards: Bull - Super Bull - Block - Super Block		
		<i>Seagear</i>	Seagear		
		<i>Mechanic</i>	230V Electro-mechanic operators Alpha - Surf - Kite - Cougar - Ger - Field - Omega - Song - Tios		
		<i>Sprint Fast</i>	"Sprint Fast" barrier		
		<i>Vela Rapid</i>	"Vela Rapid" barrier		
		<i>Sliding rack</i>	Rack motor with slowdown Off, Buzzer On and Photo2 as shadow loop		
		<i>Sliding magnetic rack</i>	Magnetic rack motor with slowdown Off, Buzzer On and Photo2 as shadow loop		
		<i>Sliding chain</i>	Chain motor with slowdown Off, Buzzer On and Photo2 as shadow loop		
		<i>Sliding magnetic chain</i>	Magnetic chain motor with slowdown Off, 70% deceleration, Buzzer On and Photo2 as shadow loop		
		<i>Erg</i>	"Erg" 230V operator		

MENU		SET	DESCRIPTION	DEFAULT	SET VALUE
5	REVERSE MOTOR	<i>On</i>	In On reverses the opening with the closing and/or vice-versa (Note: both motors and limit-swiches are reversed)	<i>Off</i>	
		<i>Off</i>	Off		
6	LOGIC	<i>Automatic</i>	Automatic	<i>Automatic</i>	
		<i>Open-stop-close-stop-open</i>	Step by step type 1		
		<i>Open-stop-close-open</i>	Step by step type 2		
		<i>2 button</i>	Two buttons		
		<i>Safety</i>	Safety		
		<i>Dead man</i>	Dead man		
7	PAUSE TIME	<i>Off</i>	OFF (semi-automatic logics)	<i>Off</i>	
		<i>1 240</i>	Setting from 1 second to 4 minutes		
8	START IN PAUSE	<i>Off</i>	The Start is not accepted during pause	<i>Off</i>	
		<i>On</i>	The Start is accepted during pause		
9	PROGRAMMING	<i>Off On</i>	Times learning start	<i>Off</i>	
10	TEST START	<i>Off On</i>	Start command	<i>Off</i>	
14	RESET	A count-down of 5 seconds will start by keeping pressed the UP button; at its end "INIT" will appear on the display as confirmation of the control board reset			
15	END	<i>Press OK to return to the display of the firmware version and to the one of inputs state</i>			
16	SPECIAL MENU	<i>Press OK to enter the special menu</i>			

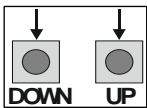

SPECIAL MENU



PRESS AT THE SAME TIME FOR 5 SECONDS TO ENTER OR TO EXIT THE SPECIAL MENU

SPECIAL MENU FUNCTIONS TABLE GATE 1 DG R2BF

For entering into the special menu move on one of the menu and press the UP and DOWN buttons at the same time for 5 s.

For exiting the special menu press END or move on one of the menu and press the UP and DOWN at the same time for 5 s.

MENU SP		SET	DESCRIPTION	DEFAULT	SET VALUE
28	OPENING TORQ 1	10 100	Opening torque Motor 1: by increasing the torque, more strenght will be required to execute the inversion in case of obstacle. Note: with hydraulic motors the torque will be on 100%	75	
29	CLOSING TORQ 1	10 100	Closing torque Motor 1: by increasing the torque, more strenght will be required to execute the inversion in case of obstacle. Note: with hydraulic motors the torque will be on 100%	75	
32	ENCODER	On	In ON enables the Encoder, in OFF it's disabled	off	
	47 ENCODER PAR. 1	xxx.	Impulses read by Encoder during operation (Motor1)		
	48 ENCODER TOT. 1	xxx.	Impulses stored during programming (Motor 1)		
32	ENCODER	Potentiometer	Enables the reading of the potentiometer with LE card	off	
	51 I.PAR.M1	-----	Reports the current position of the potentiometer on the leaf of motor 1. This parameter is useful for seeing if the potentiometer is read correctly		
	52 I.AP.M1	From the value learned to ± 100 pulses	Reports the impulses stored by the control unit when the leaf of Motor 1 is fully open		
	53 I.CH.M1	From the value learned to ± 100 pulses	Reports the impulses stored by the control unit when the leaf of Motor 1 is fully close		
32	ENCODER	Off	ON enables the Encoder; OFF shows working times learnt	off	
	65 OPENING TIME M1	xxx.s	Indicates the working times self-learning in opening and closing (Motor 1). With UP or DOWN it is possible to increase or reduce the working times		
	66 CLOSING TIME M1	xxx.s			
33	OPENING SENSITIVITY MOTOR 1	10% (Fast intervention) 99% (Slow intervention)	Adjusts the Encoder or Potentiometer intervention time on Motor 1 in opening	Off	
		Off (Intervention excluded)	Disabled		
34	CLOSING SENSITIVITY MOTOR 1	10% (Fast intervention) 99% (Slow intervention)	Adjusts the Encoder or Potentiometer intervention time on Motor 1 in closing	Off	
		Off (Intervention excluded)	Disabled		

MENU SP		SET	DESCRIPTION	DEFAULT	SET VALUE
37	SLOWDOWN SENSITIVITY MOTOR	10% (Fast intervention) 99% (Slow intervention)	Adjusts the amperometric sensitivity in slowdown. Active only if the motors are electromechanical	Off	
		With potentiometer	In case of linear potentiometer, this parameter allows to set the inversion time in slow-down from 0 to 5 seconds (= 99%)	30%	
38	POTENTIOMETER THRESHOLD OPENING 1	0 1000	Adjusts the threshold of the potentiometer intervention. The parameter self-determines in learning but can also be adjusted later. The lower the value, the slower will be the response of the potentiometer. The parameter can be set as maximum threshold at the value read on the DEBUG VPI, VP2 menu		
39	POTENTIOMETER THRESHOLD CLOSING 1				
42	POTENTIOMETER SLOWDOWN THRESHOLD OPENING 1	0 100	Adjust the threshold of the potentiometer in slowdown. By default this value is set on 1 and can be increased manually up to the maximum value read on the DEBUG VPI, VP2 Menu		
43	POTENTIOMETER SLOWDOWN THRESHOLD CLOSING 1				
46	CLOSING INVERSION	Total	In case of obstacle or edge it totally reverses the movement during closing. If active, the automatic re-closing will be attempted 5 times	Partial	
		Partial	It partially reverses direction (of about 30 cm) in case of obstacle, edge or potentiometer, then it stops		
For menu 47 and 48 see menu 32-Encoder = On					
For menu from 51 to 53 see menu 32-Encoder = Potentiometer					
59	OPENING SLOWDOWN 1	Off (*) 50	From OFF to 50% of the stroke	20	
60	CLOSING SLOWDOWN 1	Off (*) 50	From OFF to 50% of the stroke	20	
* For motors with hydraulic brake (CF) or double hydraulic brake (2CF) this parameter must be on Off					
63	DECELERATION	0 % 100% 	Adjust the passage between normal speed and slowdown speed	100%	
64	ACCELERATION	0 % 100% 	Acceleration ramp. Adjusts the motor start	100%	
70	OPENING POSITION RECOVERY	0 20 seconds	Retrieves the inertia of the motor in opening after Stop or reversing	1s	
71	CLOSING POSITION RECOVERY	0 20 seconds	Retrieves the inertia of the motor in closing after Stop or reversing	1s	
72	OPENING TOLERANCE MOTOR 1	0 100	Adjust the tolerance between stop and obstacle on Motor 1 in opening	0	
73	CLOSING TOLERANCE MOTOR 1	0 100	Adjust the tolerance between stop and obstacle on Motor 1 in closing	0	

MENU SP		SET	DESCRIPTION	DEFAULT	SET VALUE
76	PUSHING STROKE	<i>Time Pushing Stroke</i> <i>Off - 3 sec</i>	Before opening, the motor starts in closing for the set up time, in order to simplify the lock release	Off	
		<i>Repeat Lock Release</i> <i>Off - On</i>	If On, the lock will release as before as after the pushing stroke		
		<i>End</i>			
79	ANTI INTRUSION	<i>Only opening</i>	If the gate is forced manually, the control unit starts the motor to restore the state of the gate before forcing (only with limit switch)	Off	
		<i>Only closing</i>			
		<i>Opening and closing</i>			
		<i>Off</i>			
80	PUSHOVER	<i>Off</i>	Allows the leaf to make an extra move at maximum torque to ensure the tightening	Off	
		<i>Opening and closing</i>			
		<i>Only closing</i>			
		<i>Only opening</i>			
81	PERIODICAL PUSHOVER	<i>Off</i> 8	Allows the repetition of the pushover function at a distance of time adjustable from 0 to 8 hours at hourly intervals	Off	
82	MOTOR RELEASE	<i>Opening 1</i> <i>Off - 3 s</i>	If different from Off, the motor slightly reverse its direction at the end of the cycle	Off (hydraulic) 0.1 (mechanic)	
		<i>Closing 1</i> <i>Off - 3 s</i>			
		<i>Opening 2</i> <i>Off - 3 s</i>			
		<i>Closing 2</i> <i>Off - 3 s</i>			
		<i>End</i>			
83	EXTRA TIME	<i>0.0 s</i> <i>10 s</i>	With limit-switches, it adds an extra time to the movement of the motors after the limit-switches reading	<i>0.0 s</i>	
84	BRAKE	<i>Off</i> <i>100%</i>	Adjusts the braking on the limit switches	0	
85	PRE-FLASHING	<i>Only closing</i>	Pre-flashing only active before closing	Off	
		<i>0.0</i> <i>5.0 s</i>	Pre-flashing		
86	FLASHING LIGHT	<i>Normal</i>	Normal	Normal	
		<i>Light</i>	Control lamp		
		<i>Always</i>	Always ON		
		<i>Buzzer</i>	Buzzer		
87	FLASHING LIGHT AND TIMER	<i>Off</i>	The flashing light remains OFF with active timer and open gate	Off	
		<i>On</i>	The flashing light remains ON with active timer and open gate		
88	COURTESY LIGHT	<i>Off</i>	Disabled	20	
		<i>1</i> <i>240</i>	Courtesy light setting from 1sec. to 4min.		
		<i>In cycle</i>	Courtesy light in cycle		
89	TRAFFIC LIGHT RESERVATION	<i>Off</i> <i>On</i>	When setting this function the partial input will be activated to work on the auxiliary board "SEM" (traffic light management)	Off	
90	PARTIAL OPENING	<i>20</i> <i>100</i>	Setting from 20 to 100	100	

MENU SP		SET	DESCRIPTION	DEFAULT	SET VALUE
91	PARTIAL PAUSE	= Start	Pause in partial opening same as in total opening	= start	
		Off	Disabled		
		1 240	Setting from 1second to 4 minutes		
92	TIMER	Off	Turn the selected input into an input to which connecting an external clock	Off	
		On photo2			
		On partial entry			
93	FIRE SWITCH	Off	Disabled		
		On Photo2	Function active on Photocell 2		
		On Partial entry	Function active on Partial entry input		
94	24V AUX (Max. 500 mA)	Always	AUX output always Power supplied	Always	
		In cycle	AUX output active only during cycle		
		Opening	AUX output power supplied only during opening		
		Closing	AUX output power supplied only during closing		
		In pause	AUX out put power supplied only during pause		
		Autotest	Security test		
		In cycle and phototest	AUX output only during cycle with fototest function active		
		Positive brake management	Positive Electrobrake (24V in On with stationary gate)		
		Negative brake management	Negative Electrobrake (24V in On with gate in cycle and 1 second before the start)		
		Negative brake and Photocell management	Negative electrobrake not active on intervention of the photocell		
		Open gate warning Light	1 flash per second in opening 2 flashes per second in closing Steady lit in Stop or Open		
		Lock	Simulates the activation of the lock command. Note: you need a relay and an external power supply to activate the lock		
		Opening and open	24V AUX will be active only during opening and with open gate		
		Courtesy light	It will work as per Menu-88 settings		
		Start 3 s	If active, the 24VAUX output is activated for 3 seconds at every Start input, every photocells or edge intervention		
Barrier Led lights	the 24Vaux output will pilot the lights on the barrier so that, with the beam closed the light is on, with the beam opened the light is switched off and with the moving beam the light is blinking				

MENU SP		SET	DESCRIPTION	DEFAULT	SET VALUE
95	FOTOTEST	<i>Photo 1</i>	Self-test active only on photo 1	<i>Off</i>	
		<i>Photo 2</i>	Self-test active only on photo 2		
		<i>Photo 1 and 2</i>	Self-test active on photo 1 and 2		
		<i>Off</i>	Disabled		
		<i>Edge</i>	Self-test active only on security edge		
		<i>Photo 1 and Edge</i>	Self-test active on photocell 1 and security edge		
		<i>Photo 2 and Edge</i>	Self-test active on photocell 2 and security edge		
		<i>Off</i>	Disabled		
97	PHOTOCELL 1 SHADOW LOOP 1	<i>Closing</i>	If the photocell is occupied, it reverses the movement in closing; during the pause, it prevents the reclosing	<i>Closing</i>	
		<i>Opening and closing</i>	If active the photocell blocks the movement as long as it is busy; when released, the opening movement continues		
		<i>Stop</i>	If the photocell is activated before the Start input, the Start will be ignored. If the photocell is activated after the Start input, the photocell will be ignored. If the photocell is activated during closing, the gate will reopen		
		<i>Stop and close</i>	In closing, the photocell stops the movement until it is occupied; when released the closing movement continues		
		<i>Close</i>	The photocell stops the gate until it is occupied in both opening and closing; when released, it gives a closing command (it closes one second after its release)		
		<i>Pause reload</i>	If occupied, during pause the photocell recharges the time of pause. In closing it reverses the movement		
		<i>Shadow loop</i>	Until occupied, with open gate, it prevents reclosing. It is switched off during closing		
		<i>Delete pause time</i>	If occupied during opening, pause or closing, the gate reopens completely and closes without observing the pause time		
		<i>Shadow loop RP (pause reloading)</i>	If the shadow loop is temporarily released, the pause time is reloaded before closing		

MENU SP		SET	DESCRIPTION	DEFAULT	SET VALUE
98	PHOTOCELL 2 SHADOW-LOOP2	<i>Closing</i>	If the photocell is occupied, it reverses the movement in closing; during the pause, it prevents the reclosing	<i>Opening and Closing</i>	
		<i>Opening and closing</i>	If active the photocell blocks the movement as long as it is busy; when released, the opening movement continues		
		<i>Stop</i>	If the photocell is activated before the Start input, the Start will be ignored. If the photocell is activated after the Start input, the photocell will be ignored. If the photocell is activated during closing, the gate will reopen		
		<i>Stop and close</i>	In closing, the photocell stops the movement until it is occupied; when released the closing movement continues		
		<i>Close</i>	The photocell stops the gate until it is occupied in both opening and closing; when released, it gives a closing command (it closes one second after its release)		
		<i>Pause reload</i>	If occupied, during pause the photocell recharges the time of pause. In closing it reverses the movement		
		<i>Shadow loop</i>	Until occupied, with open gate, it prevents reclosing. It is switched off during closing		
		<i>Delete pause time</i>	If occupied during opening, pause or closing, the gate reopens completely and closes without observing the pause time		
		<i>Shadow loop RP (pause reloading)</i>	If the shadow loop is temporarily released, the pause time is reloaded before closing		
		<i>Stop and open</i>	If the photocell is activated during opening, the gate will stop and will continue opening movement only when the photocell is released. The photocell is ignored during closing		
		<i>Stop N.O.</i>	Stop connection on ERG push-button panel		

MENU SP		SET	DESCRIPTION	DEFAULT	SET VALUE
100	SECURITY EDGE 1	<i>Normal</i>	Normal N.C. contact	<i>Normal</i>	
		<i>8K2</i>	Edge is active and protected by a 8K2 resistor		
		<i>8K2 Double</i>	Allows to connect two 8K2 protected edges		
		<i>Photo 1 10K</i>	Edge works as a photocell protected by a 10K resistor		
		<i>Photo 1 10K Double</i>	It is possible to connect two photocells protected by a 10K resistor		
102	SECURITY EDGE 1 DIRECTION	<i>Opening and closing</i>	Active in opening and closing	<i>Opening and Closing</i>	
		<i>Only opening</i>	Active only in opening		
		<i>Only closing</i>	Active only in closing		
104	SELECT LIMIT SWITCH	<i>Automatic</i>	Limit switch in automatic recognition	<i>Automatic</i>	
		<i>Only opening</i>	Active limit-switch in opening only		
		<i>Only closing</i>	Active limit-switch in closing only		
		<i>Motor internal</i>	To be activated if there is a limit-switch that stops the motor phase		
		<i>Ext</i>	Limit-switch connected on the interface board for 4 cams limit-switches		
105	MASTER-SLAVE	Master	On applications with two motors in master-slave, it allows to set the control unit as master		
		Slave	On applications with two motors in master-slave, it allows to set the control unit as slave		
		Off	Disabled		
106	DIAGNOSTICS	<i>1 10</i>	Shows last event (See alarms table)		
107	MAINTENANCE CYCLES	<i>100 240000</i>	Setting from 100 to 240000	<i>100000</i>	
108	PERFORMED CYCLES	<i>0 240000</i>	Reports the executed cycles. Keep pressed OK to reset the cycles	<i>0</i>	
109	THERMOMETER	<i>On Off</i>	In ON you can insert the piston oil temperature probe combined with the LE card	<i>Off</i>	
110	LOWER THRESHOLD TEMPERATURE	<i>From -20° to +50°</i>	Regulates the activation threshold of the motor oil heater	<i>-10°</i>	
111	UPPER THRESHOLD TEMPERATURE	<i>From -20° to +50°</i>	Regulates the deactivation threshold of the motor oil heater	<i>0°</i>	

MENU SP		SET	DESCRIPTION	DEFAULT	SET VALUE
112	PASSWORD	----	Allows the entering of a password blocking the control unit parameters modification	----	
113	EMERGENCY	<i>Off</i>	Disabled	<i>Off</i>	
		<i>Ultima apertura</i>	Without main power, if batteries are lower than 22V the gate opens and stay opened. The gate recloses when the power is back		
		<i>Ultima chiusura</i>	Without main power, if batteries are lower than 22V the gate closes and stay closed until the power is back		
117	ALWAYS CLOSE	<i>Off 240 seconds</i>	Without main power if the gate is manually opened, when the power is back the gate will reclose only after the time set (from 0 to 240 seconds)	<i>Off</i>	
119	DISPLAY WRITING SPEED	<i>From 30% to 100%</i>	See Note 3 below	<i>80%</i>	
120	BASIC MENU	Press OK to exit the special menu. The special menu switches off automatically after 20 minutes			

Note 1: The * indicates that the default value or the menu may change depending on the selected motor type.

Note 2: After initialization the parameters "motor type" and "limit switch type" remain on the value chosen in the setup program.

Note 3: Display writing speed set on 30% keeps writing slow; Display writing speed set on 100% keeps writing fast. Please note that speed does not change on JOLLY 3 display.

MENU FOR INPUT CHECK

The settings of the control unit are made through the UP, DOWN and OK buttons. The UP and DOWN buttons to scroll through the MENUS and SUBMENUS. By pressing OK you enter from MENU into SUBMENU and confirm the choice. Moving in the 1-LANGUAGE menu pressing the UP and DOWN buttons at the same time you access the SP MENU for special settings. Moving in the 1-LANGUAGE menu pressing the OK button for 5 seconds, you enter the CHECK MENU, where you can check the operating status of all inputs.

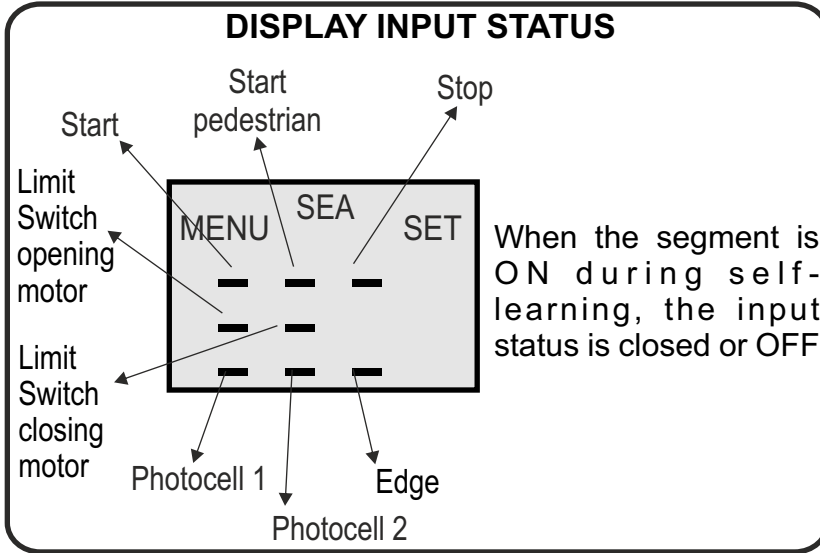

Initial system

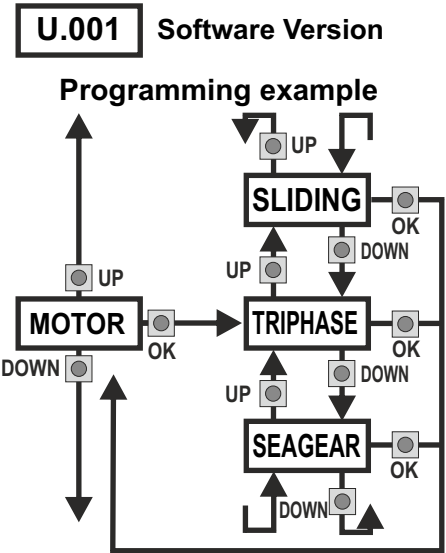

MENU FUNCTION TABLE CHECK GATE 1 DG R2BF INPUTS
To access the Menu for input check keep pressed OK for about 5 seconds.

MENU		Description		Description
START	—OK<	Enabled	Start test	The contact must be a N.O. Contact . When activating the related command on the display SET lights up, the input works. If SET is always on, check the wirings.
		Blocked		
STOP	—OK<	Enabled	Stop test	The contact must be a N.C. Contact. When activating the related command on the display SET lights up, the input works. If SET is always on, make sure that the contact is a N.C. Contact
		Blocked		
PEDESTRIAN START	—OK<	Enabled	Pedestrian Start test	The contact must be a N.O. Contact. When activating the related command on the display SET lights up, the input works. If SET is always on, check the wirings.
		Blocked		
EDGE	—OK<	Enabled	Safety edge test	The contact must be a N.C. Contact. When activating the related command on the display SET lights up, the input works. If SET is always on, make sure that the contact is a N.C. Contact
		Blocked		
PHOTO1	—OK<	Enabled	Photocell 1 test	The contact must be a N.C. Contact. When activating the related command on the display SET lights up, the input works. If SET is always on, make sure that the contact is a N.C. Contact
		Blocked		
PHOTO2	—OK<	Enabled	Photocell 2 test	The contact must be a N.C. Contact. When activating the related command on the display SET lights up, the input works. If SET is always on, make sure that the contact is a N.C. Contact
		Blocked		
LIMIT SWITCH OPENING			Opening limit switch test	The contact must be a N.C. Contact. When activating the related command on the display SET lights up, the input works. If SET is always on, make sure that the contact is a N.C. Contact. Menu active only on version with limit switches
LIMIT SWITCH CLOSING			Closing limit switch test	The contact must be a N.C. Contact. When activating the related command on the display SET lights up, the input works. If SET is always on, make sure that the contact is a N.C. Contact. Menu active only on version with limit switches
END		Exit menu		

Note: If the **Stop**, **Photocell 1** and **Photocell 2**, **Edge** contacts are not bridged in self-learning, they will be deactivated and can be reactivated through this menu, without repeating times self-learning

RADIO TRANSMITTER SELF LEARNING WITH RECEIVER ON BOARD OF CONTROL UNIT

! WARNING: Make the radio transmitters programming before you connect the antenna and insert the receiver into the special CMR connector (if available) with turned off control unit. With RF UNI and RF UNI PG module it will be possible to use both Coccinella Roll Plus transmitters and radio transmitters with fixed code. The first memorized radio transmitter will determine the type of the remaining radio transmitters. If the receiver is a **Rolling Code**, **press twice** the button of the radio transmitter that you want to program to memorize the first TX. In the case of **transmitters with fix code** it is necessary to **press 1 time** the button of the transmitter you want to program to store the first remote control

- Notes:**
- Enter radio transmitters learning only when the working cycle stops and the gate is closed.
 - You can store max. 2 of the available 4 functions. If the control unit receives a code which was already associated to another function it will be updated with the new function.

RF UNI	16 USERS Whitout memory 800 USERS With additional memory MEM
RF UNI PG <i>Old Model</i>	100 USERS Fixed code 800 USERS Roll Plus
RF UNI PG <i>New model</i>	800 UTENTI Fixed code 800 UTENTI Roll Plus

TABLE EXAMPLE

Transmitter button Memory location	1	2	3	4	Serial number	Customer
0						
1						
2						
3						

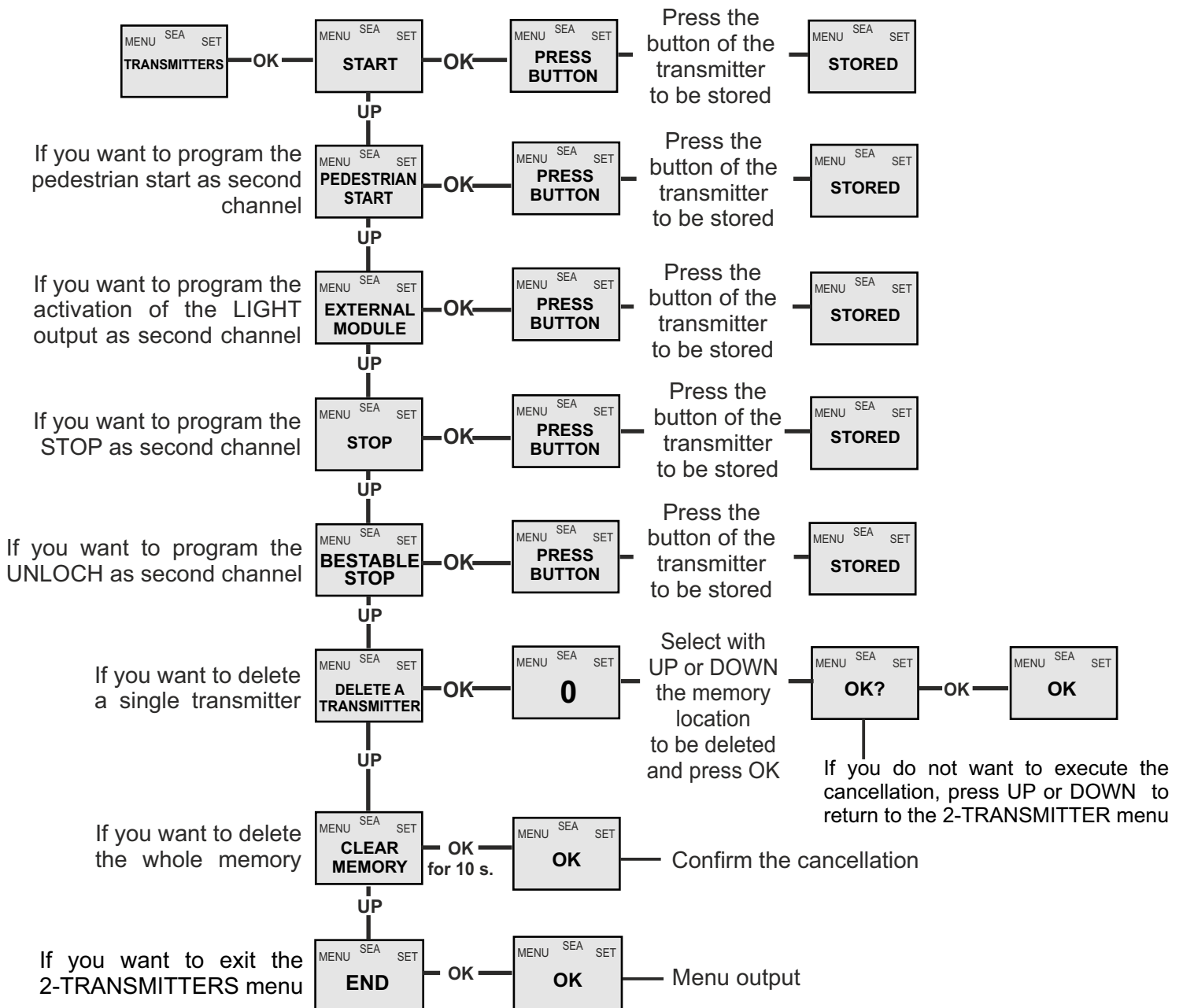

RADIO TRANSMITTER SELF LEARNING

WITH RF FIX RECEIVER ON BOARD OF CONTROL UNIT

⚠ WARNING: Make the radio transmitters programming before you connect the antenna and insert the receiver into the special CNS connector (if available) with turned off control unit. With the RF FIX module it will be possible to use only radio controls with fixed code.

Select through the display 2-TRANSMITTERS and press OK, now select with the UP and DOWN buttons, the command to which you want to associate the button (it is possible to associate max. 2 commands) and press OK to confirm the choice, now press the button of the radio transmitter which you want to associate. If the storage is successful, the display will show "Stored". In the 2-TRANSMITTERS MENU it is possible to select "Start" (to associate a Start command), "Pedestrian start" (to associate a Pedestrian Start), "External Module" (For the activation of a contact on the EXP output), "Stop" (To associate the STOP command to the TX), "Unloch" (to associate the release of the electric brake to the transmitter), "Delete a transmitters" (To delete the single transmitter only if it is a Rolling Code Plus), "Clear memory" (To delete all TX), "End" (To exit menu 2-TRANSMITTERS). To release the electric brake it is necessary to give three consecutive pulses, the 4th will reactivate the lock of the electric brake.

- Notes:**
- Enter radio transmitters learning only when the working cycle stops and the gate is closed.
 - It will be possible to memorize up to max. 16 codes (buttons) adding the MEM memory it will be possible to store up to 496 different codes.
 - You can store max. 2 of the available 4 functions. If the control unit receives a code which was already associated to another function it will be updated with the new function.

DELETE TRANSMITTERS FROM THE RECEIVER

With modules different from RF FIX, it will be possible to delete only the entire memory of the receiver. Proceed as follows: select from the menu 2-TRANSMITTERS: "Clear memory" and hold the OK button until the display shows the message "OK".

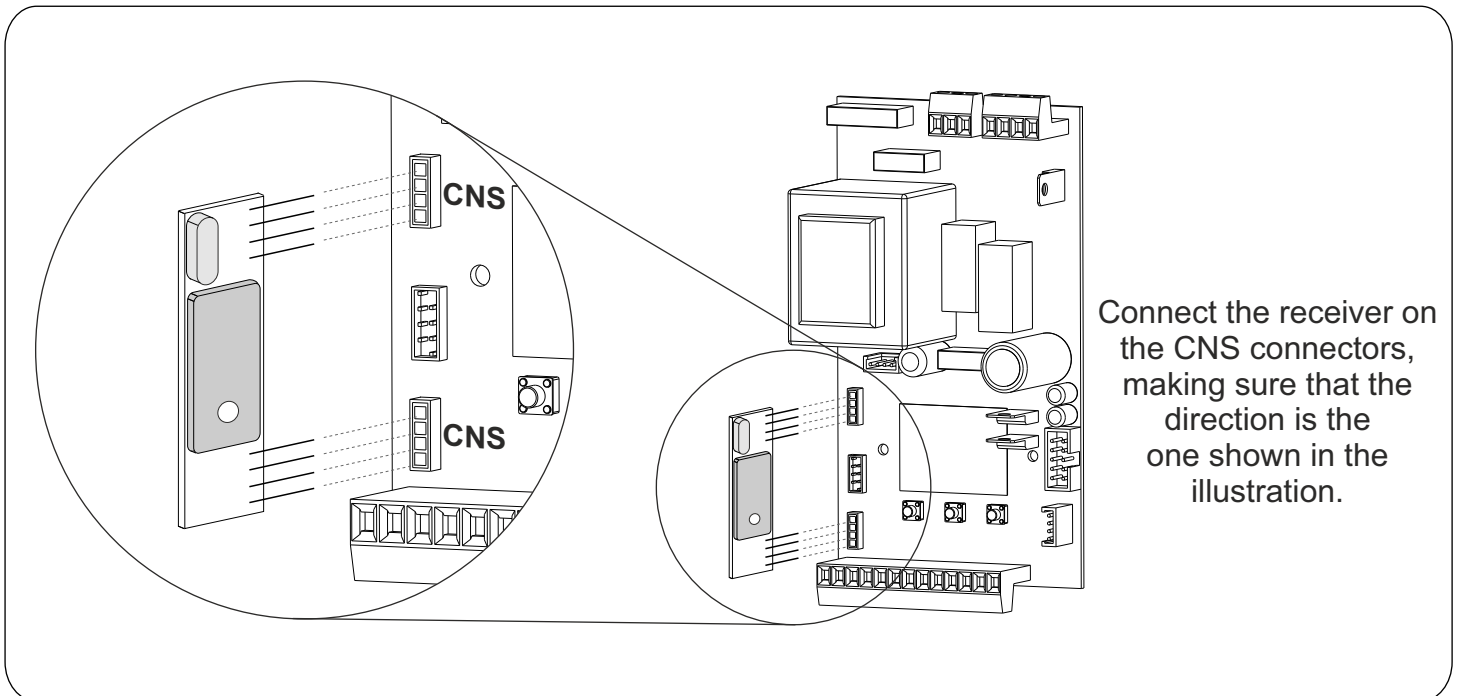

START - STOP - PEDESTRIAN START - ANTENNA - PHOTOCELL

Photocell 1 and Photocell 2 Connections

+ = 24V \equiv Accessories COM = 0V PH1 = Photocell contact 1 PH2 = Photocell contact 2

Note 1: If the photocells are not connected, it is not necessary put a jumper between the clamps (6 and 7 and/or 6 and 8 of the CN1 terminal)

Note 2: For self-test connect the TX to the 24VAux clamp and activate the Self-test function

Note 3: On the 95-FOTOTEST menu you can also activate the self-test even on the single photocell

Note 4: The standard setting of the photocell 1 is in "Closing" and the one of the photocell 2 is in "Opening". The photocell 2 can be set also as TIMER (see TIMER function)

Note 5: For photocells settings, see menu 97-98

Options AUX 24V \equiv max 500mA can be set with on-board Display or with Jolly device.

Through the Jolly programmer it is possible to chose when having tension on the AUX output. The options are: **Always, In cycle, Opening, Closing, In pause, Autotest, In cycle and fototest, Positive brake management, Negative brake management, Negative brake management-photocellule, Gate open warning light, Lock, Opening and open.**

PEDESTRIAN START (N.O.) The pedestrian start can be connected between the connectors 2 and 4 of the CN1 terminal

This input allows a partial opening, the opening space can be set through the on-board display or through the JOLLY3 device.

Note1: The contact for partial opening is a N.O. Contact (Normally open). Holding START starts the TIMER function, releasing the pedestrian start, the operator repeats the pause and then performs the closing. In the case of triggering a safety device the timer will automatically reset after 6 seconds.

Note2: In 2 BUTTONS logic it is necessary to keep pressed the Start Ped. to re-close the automation.

Note3: In deadman logic this button executes the re-closing if you keep it pressed.

Note4: When closed during pause, the gate will reclose only after this input has been reopened.

TIMER activation: This input can be transformed into TIMER (See TIMER).

Note5: When using the Sem card, the pedestrian input can be used as priority in closing through the 89-TRAFFIC LIGHT RESERVATION function.

STOP (N.C.) The STOP is connected between the clamps 2 and 5 of the CN1 terminal

The pressure on this button immediately stops the motor in any condition/position. A start command is needed to re-start the movement. After a stop the motor always re-starts in closing

START (N.O.) The START is connected between the clamps 2 and 3 of the CN 1 terminal.

An impulse given to this contact opens and closes the automation depending on the selected logic it can be given by a key switch, a keypad, etc. To connect the other devices refer to the related instructions leaflets. (ie. loop detectors and proximity switches).

Note1: In DEAD MAN logic it is necessary to keep pressed the Start for the opening of the automation.

Note2: In 2 BUTTONS logic this button performs the opening

TIMER Can be activated through on-board display or through the Jolly3 programmer. In both cases it's a N.O. contact which provokes the opening of the automation keeping it open until it is activated. When it's released, the gate attends the set pausing time and executes the reclosing. The TIMER command can be activated on the inputs FOTO2, START PEDESTRIAN

Note1: If activated on the pedestrian entry, the pedestrian will be disabled also on the radio transmitter

Note2: In case of intervention of a security device during the timer (Stop, Ammeter, Edge), to restore the movement it will be necessary to give a start impulse

Note3: In case of no power supply with open gate and active Timer the control unit will restore its use, otherwise if during restore of the power supply the TIMER is not activated it will be necessary to give a start impulse to reclose

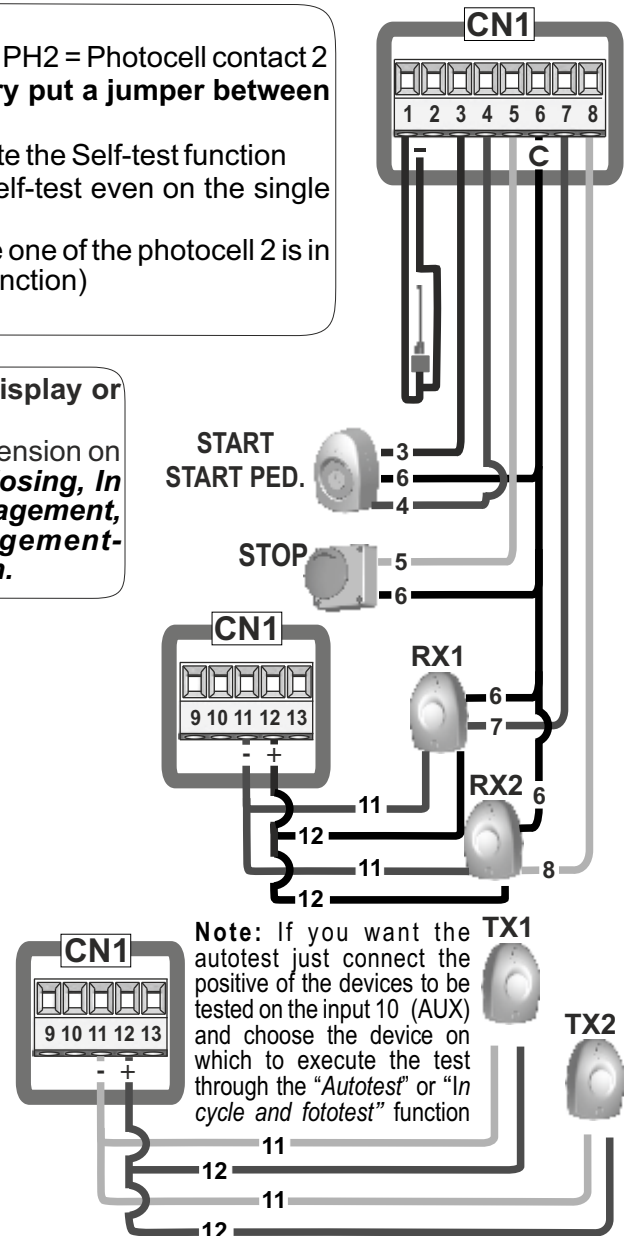

ENCODER OR AMPEROMETRIC MANAGEMENT

AMPEROMETRIC DEVICE FOR ELECTROMECHANICAL OPERATORS

This control unit comes with an obstacle detection system working only on electromechanical operators allowing to have the reversing on obstacles and the automatic detection of the stops. Sensitivity adjustable from OFF to 99% inside the special menu. The more the percentage is high the more the obstacle detection will be difficult. On hydraulic unit this parameter will be always OFF.

ENCODER (CN5 Connector)

The Encoder, unlike the amperometric sensor, can be used both on electromechanical and hydraulic operators. The Encoder allows the detection of the gate position and its reversing in case of obstacles. To use the ENCODER it is necessary to enable it inside the special 32-ENCODER Menu. The sensitivity on the obstacle is adjustable from 0 - 99%. The higher the percentage is the more it will be difficult to detect the obstacle.

NOTE: If the Encoder is activated it is possible to visualize in the special menu the total memorized impulses and the partial impulses executed by the motor.

POTENTIOMETER "GATE POSITION"

If the POSITION GATE is present on hydraulic motors it will be possible to have the inversion on obstacles by adjusting the menus 33- MOTOR1 OPENING SENSITIVITY, 34- MOTOR1 CLOSING SENSITIVITY, 37- SLOWDOWN SENSITIVITY.

ATTENTION: The first operation, after power failure will be for searching the mechanical stops at the end of the run.

POTENTIOMETER MANAGEMENT (Position Gate)

(Available from revision 013 only on prepared motors)

The position gate ensures the correct position of the gate and the inversion on the obstacle, helping the installer to pass the certification of the automation. To connect the potentiometer you must use the LE card (Cod.23001256) and set with Dip Switches 1 and 2 both in OFF. With the potentiometer it is possible to access the hidden **DEBUG** menu to check the maximum settable value as threshold in normal and slow-down speed. To access this menu you have to press, in the menu that displays the firmware version UP and OK at the same time until the menus VP1 speed of potentiometer 1 will appear. To view the speed of the potentiometer on the related menu, press OK. To exit the **DEBUG** menu go to **END** and press OK. If the reading of the potentiometer is reversed relative to the movement of the motor, on the display will appear the alarm "Potentiometer direction" and you will have to reverse the brown wire with the green one and repeat programming. For a quick inversion on the obstacle you have to lower the sensitivity parameters.

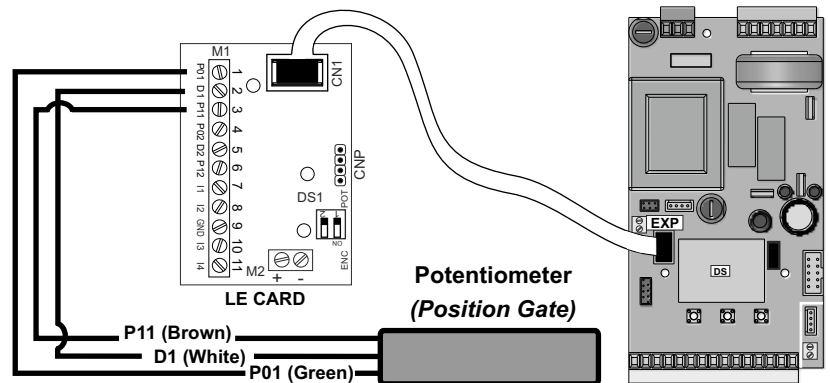

TEMPERATURE PROBE MANAGEMENT

The temperature probe detects the temperature of the motor oil and in the case where the temperature falls below the set temperature thresholds, it activates the heating of the oil bringing it back to the defined values

in the range of set temperature. To connect the probe you must use the LE card (Cod.23001256) and set it with the DIP SWITCH 1 and 2 both on OFF. If the temperature probe is present, you can adjust the high and low temperature thresholds through the menus 110 and 111 and activate the "Thermometer" in the menu 109.

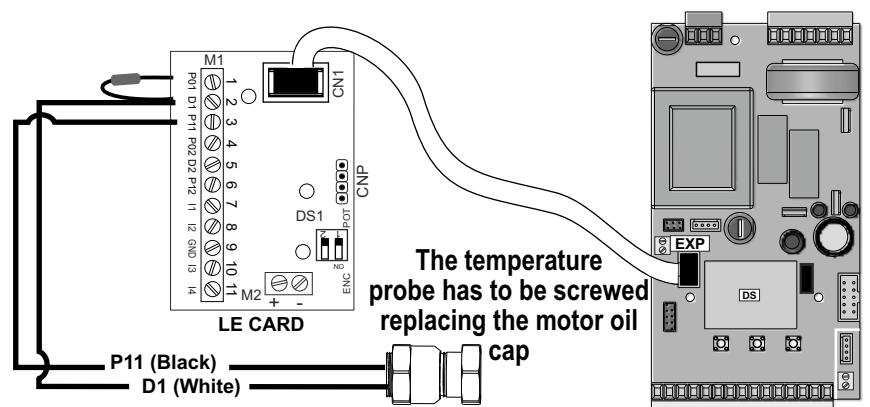

WARNING LAMP - SAFETY EDGE - 10K PHOTOCELL - BUZZER

24V $\overline{\text{---}}$ FLASHING LAMP 3W MAX 12 and 13

Flashing Lamp 24V $\overline{\text{---}}$ (Accessories) 3W max. (Control lamp)
 The Flashing Lamp can be connected between the 24V $\overline{\text{---}}$ clamps (Accessories) and FL (-) of CN 1. The Flashing lamp advises that the automatic gate is moving with 1 flash/second in opening and 2 flashes / second in closing. During pause it remains switched on. Through the warning lamp it is also possible to identify alarms lied to the STOP, PHOTOCELL 1, PHOTOCELL 2 and EDGE devices. Through the display or the JOLLY 3 programmer it is possible to activate the pre-flashing function and/or to modify the function of the warning lamp choosing between fix flashing or control lamp. **The pre-flashing can be timed from 0 to 5 seconds otherwise it is possible to set it before closing only.**

Example of flashing lamp and edge connections

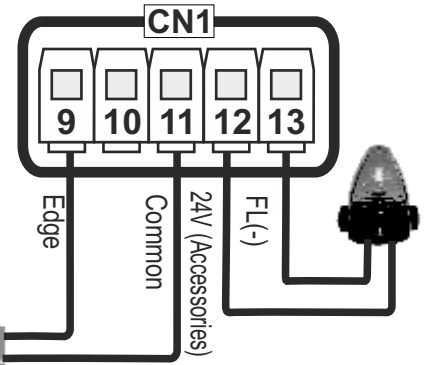

Safety edge

SAFETY EDGE 9 and 11

Between clamps 9 and 11 on the terminal CN1 it is possible to connect an active Safety Edge. When pressed, the Safety Edge opens the contact causing a partial inversion of the movement both in opening and in closing. The Safety Edge output can be set «only in closing», «only in opening» or both directions

Note1: Through the on-board display or the JOLLY 3 programmer it is possible to activate the balanced edge 8K2, in this case the edge contact is controlled by a special resistance value revealing the eventual involuntary short-circuit of the device. In case of imbalance of the device a special alarm will be shown on the on-board display or on the JOLLY programmer.

Note2: Self-test can be made also on a radio powered Edge (See Auto-test Menu)

10K PHOTOCELL or DOUBLE 10K PHOTOCELL 9 and 11

Between clamps 9 and 11 on the terminal CN1 it is also possible to connect a 10K Photocell or two 10K Photocells. In this case it is necessary to set it on menu 100 - EDGE as Photo10K (or Photo1 10K Double), then it will run following settings on menu 97 - PHOTO 1.

Nota1: The use of a 10K Photocell allows to get further protection in case of short-circuit on the cables.

Example of two 10K Photocells connections

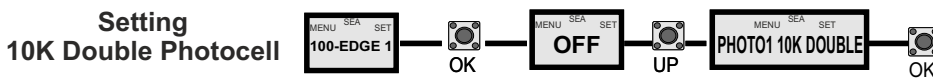
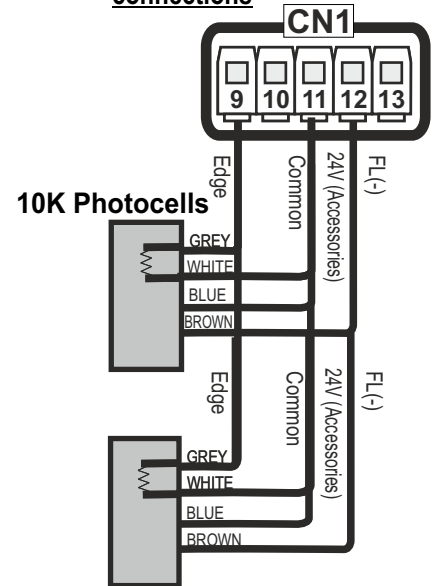

**IMPORTANT NOTE: INSTEAD OF THE FLASHING LAMP, YOU CAN ALSO CONNECT A BUZZER
 REMEMBER TO SET THE 86-MENU ON «BUZZER»**

24V BUZZER 12 and 13

Buzzer (24V $\overline{\text{---}}$) Audible Alarm
 Use an autoswinging buzzer 24V $\overline{\text{---}}$ of 100 dB.
 The buzzer will be switched on after two consecutive activations of the entrapment protection.
 To reset the allarm it is necessary to push the button STOP.
 Anyway after 5 minutes the buzzer will stop to sound and the automation stands still waiting for commands.

Example of 10K Photocell and Buzzer connections

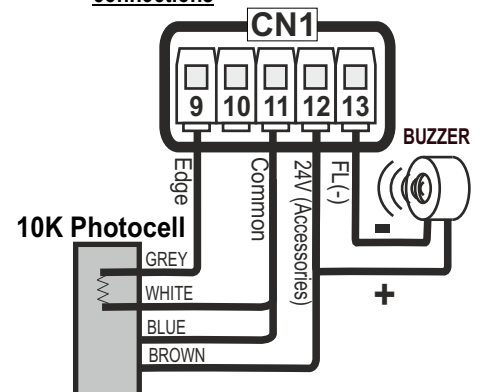

If Buzzer does not work, check the 86-FLASHING LIGHT menu is set on "Buzzer"

COURTESY LIGHT, MOTORS, CAPACITY AND POWER SUPPLY CONNECTIONS

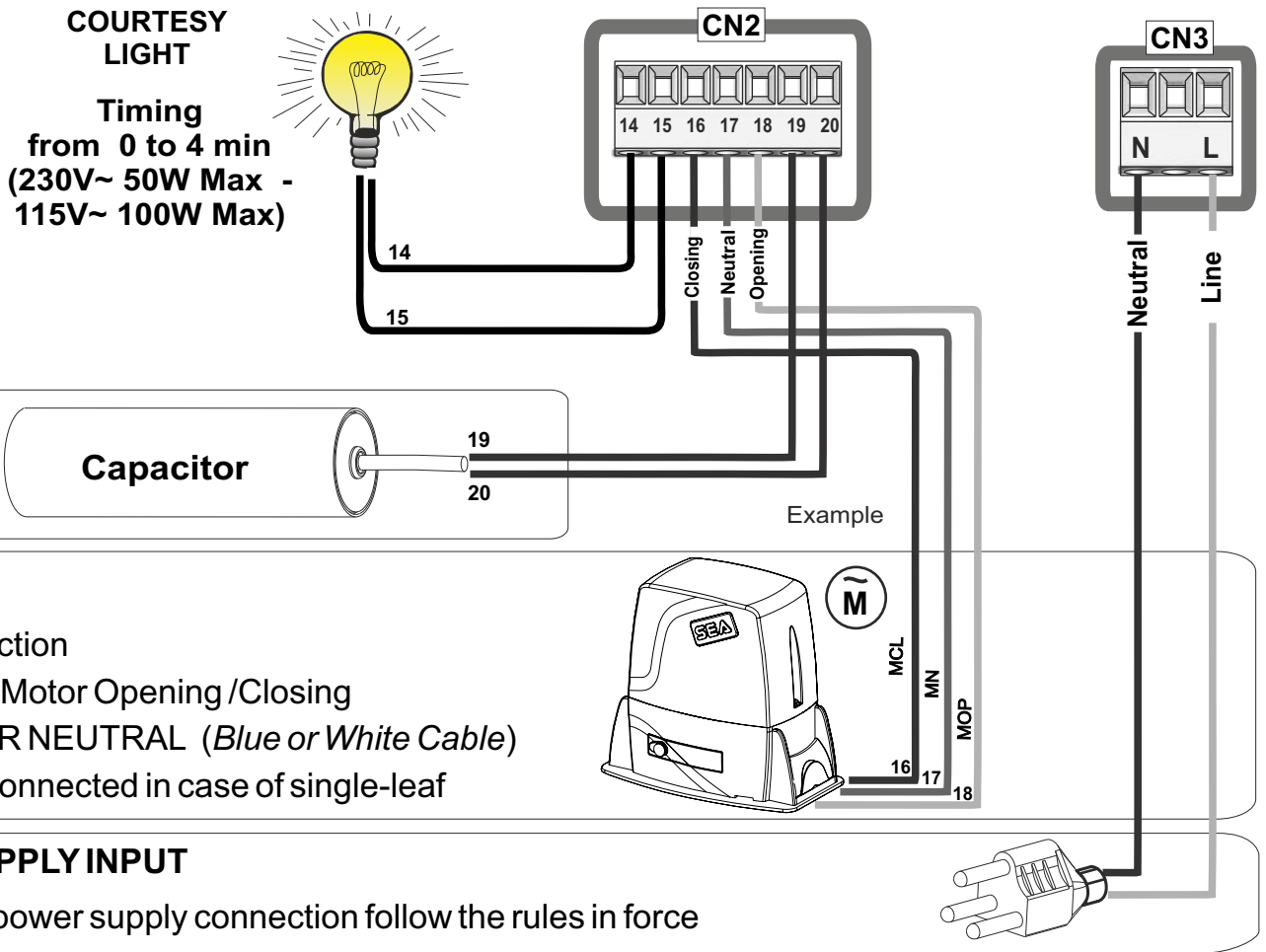

THREE-PHASE MODULE CONNECTION

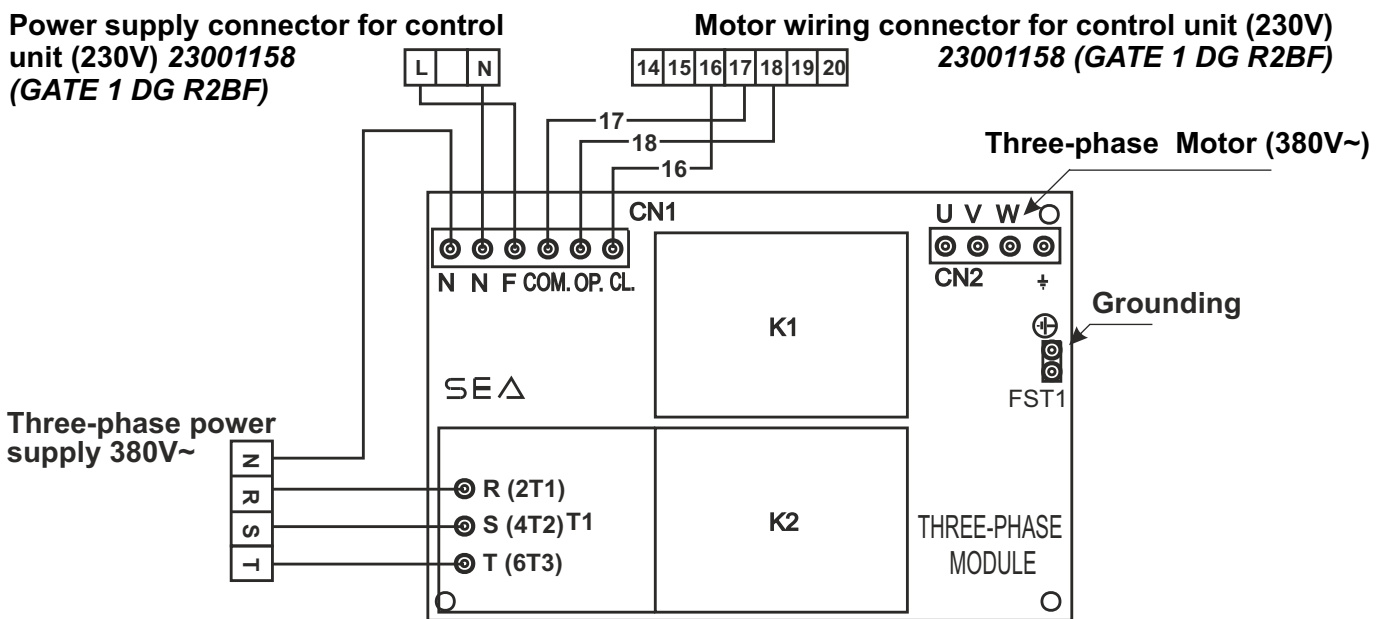

- K1-K2 = Terminals 230V~ 16A
- T1 = Thermal switch (limit 3,7A)
- CN1 = Power supply connector for elect. control unit (220V)
- CN2 = Power supply connector for three-phase motor (380V)
- FST1 = Grounding faston

Important note:
 select in the settings of the motor menu the configuration "Triphase - Bollards"

MASTER-SLAVE FUNCTION

The **MASTER-SLAVE** function is useful in case of opposite sliding gates or opposite barriers; **When using this function all devices** (photocells, key-switches, safety edges etc.) **must be connected to the Master unit**, which manage also the motion of the motor connected to the Slave unit. To set an installation with two motors in **MASTER-SLAVE** it is recommended to do as follows:

- 1) Set the two motors as if they were two independent installations, make sure that the individual motor works properly and that the limit switches (when present) are read properly.
- 2) Once sure of the correct functioning connect the control unit MASTER to the control unit SLAVE through the special clamp (Code SEA 23001220).
- 3) Now set the control unit, which has to manage the commands and motor 1 (photocell, keyswitch, STOP, safety edge etc.) as MASTER and the other one which will move motor 2 as SLAVE.
- 4) Turn off the power on both control panels and then turn on again

Note 1: The MASTER-SLAVE settings on the control unit are in the 105 special menu

Note 2: All these operations can also be managed through the JOLLY3 programmer).

Note 3: On the SLAVE it is possible to set the following functions only: torque, speed, motor type, slowdown speed, acceleration, deceleration, position recovery, AUX and motor inversion. All other parameters will be set only by the MASTER control unit.

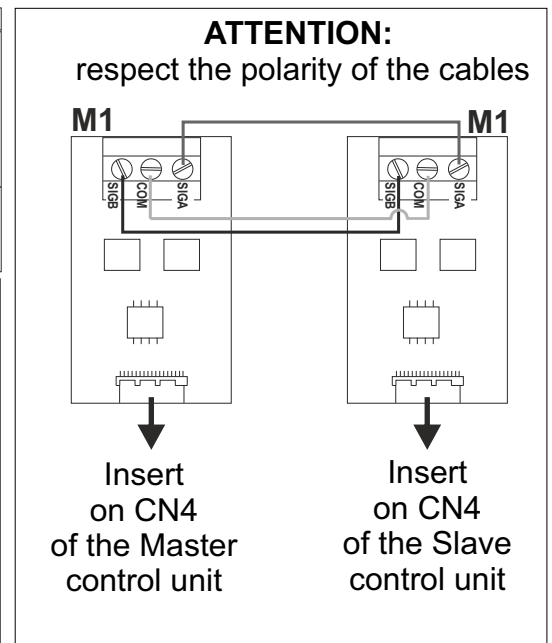
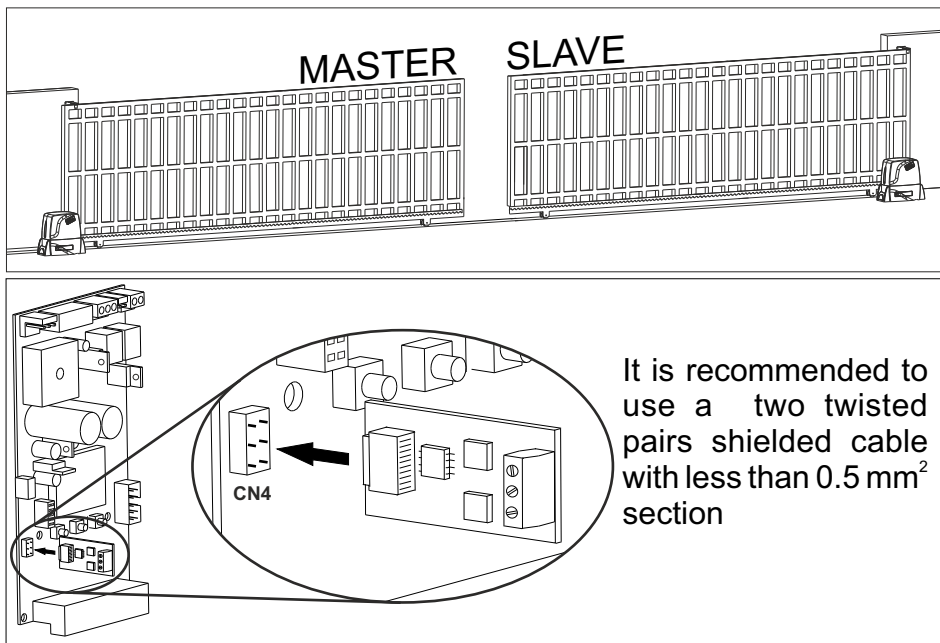

SEM2 CONNECTION

24V~ / $\overline{\text{---}}$ (ac/dc)
or
230V~

SEM2 setting as courtesy light:

- 1) connect the SEM2card
- 2) select mode 3 on the SEM2 card dip-switch 2,3,4 = off,on,off
- 3) connect the courtesy light on Relay 2 of the SEM2 card
- 4) set the timing on the control unit menu - 88

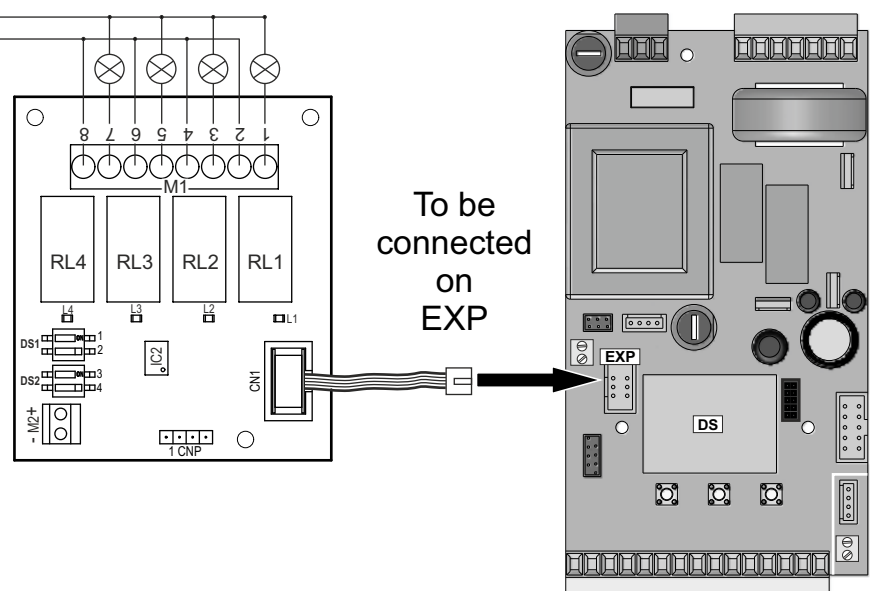

SAFETY LOOP CONNECTIONS

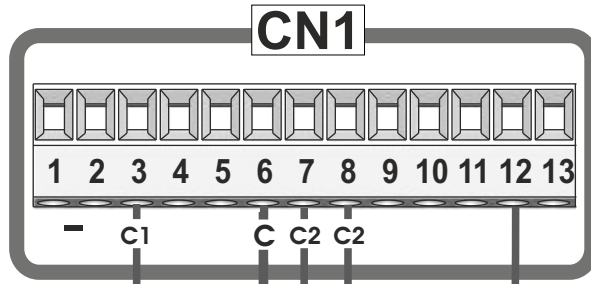

DRAWING SHOWS HOW TO EVENTUALLY CONNECT THE MAGNETIC LOOP

C1 = CONTACT OPEN
 C2 = CONTACT CLOSED
 12 = 24 V ---
 C = 0 V ---

Safety exit loop (loop 1)

Connecting scheme of loop detector 1 reader

7 = Contact photocell 1 (N.C.)
 6 = Common

Shadow loop (loop 2)

Connecting scheme of loop detector 2 reader

8 = Contact photocell 2 (N.C.)
 6 = Common

Note: Please set 98-PHOTOCELL2 - LOOP2 menu to "Shadow loop"

Free exit loop (loop 3)

Connecting scheme of loop detector reader

3 = Contact start (n.o.)
 6 = Common

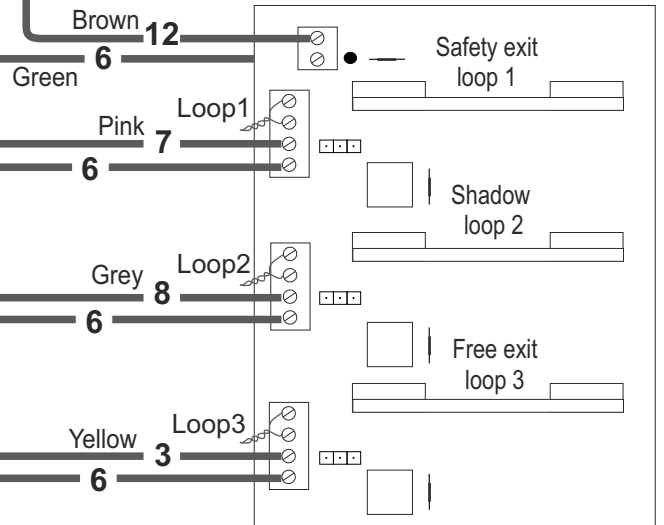

MAGLOCK 12V CONNECTIONS

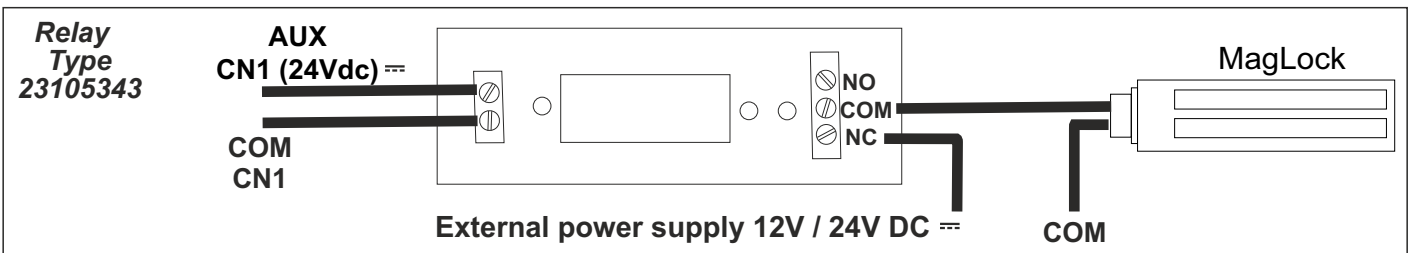

NOTE:
 For both Relay types it is necessary to set menu 94 - 24V AUX on "negative brake management"

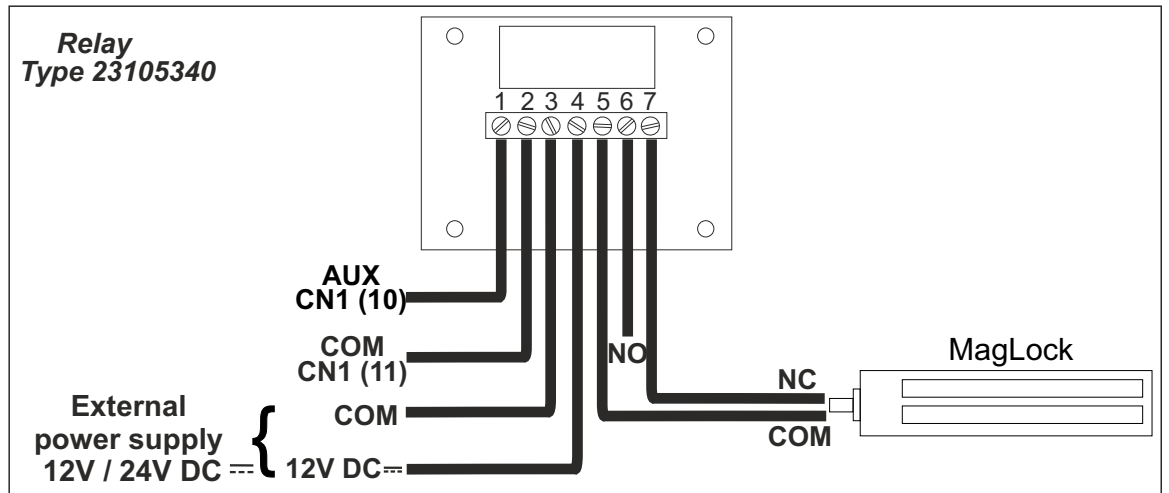

ALARM DESCRIPTION

Signals	Kind of alarm	Solutions
FAILURE MOTOR	Motor current failure	Make sure there are no short circuits on the motor or on the control unit
FAILURE24	AUX output voltage failure	Make sure there are no short circuits on the wiring or on the control unit and no overloads
FAILURE24VAUX OVERLOAD EXIT 10 CONNECT ACCESSORIES EXIT 12	AUX output voltage failure	Make sure there are no short circuits on wiring or control unit and no overload. The 24Vaux exit is an output which can be set with a maximum load of 500mA; if you do not require an adjustable 24V, use the 24V present on terminal 12 (+) and use the negative on exit 11 (COM) and NOT on exit 13
FAILURE NET	Power supply failure	Check the network or the F2 fuse
FAILURE AUTO-TEST	Photocells auto-test failure	Check the photocells operation and / or connections on the control unit
FAILURE LIMIT-SWITCH	Limit-switch activation failure	Check the operation of both limit-switches and/or correspondence between movement direction of the motor and the engaged limit-switches
FAILURE FLASHING LIGHT	Flashing lamp failure	Check connections and / or conditions of the lamp
FAILURE POTENTIOMETER	Potentiometer failure	The message appears only if the potentiometer is ON and the potentiometer (LE) card is broken or not connected
FAILURE POT.1 DIRECTION	Potentiometer 1 direction failure	Invert potentiometer's cables (invert green with brown)
FAILURE THERMOMETER	Failure thermometer	The message appears only if the thermometer is ON and the potentiometer card (LE) is broken, not connected or incorrectly set
FAILURE SLAVE	Slave failure	Check the Master/Slave circuit's connection and be sure the function Slave is set on Slave circuit (105-menu)
FAILURE EDGE	Edge failure	Check edge's metal thread and edge's connection cables; make sure the contact is closed by looking on display
FAILURE PHOTO1 10K	10K photocell1 failure	Check photocells 1 connections or possible short circuits; check if photocell is well powered. Make sure that a 10K protection photocell has been connected

Note 1: If in the diagnostics shows "Max. cycles reached", do the maintenance and / or reset the number of cycles performed.

Note2: To exit from the error messages, press OK. If the error persists, make all required checks for the specific error and / or disconnect the device that generates the error to see if the error disappears.

At each opening and closing of the automation the flashing light will blink. It blinks once per second during opening and twice per second during closing, while it remains lit during pause.

It is possible to view the alarms also on the flashing light or on the control lamp, simply by observing the number of flashes emitted and verifying the reference in the table below:

Blinks	Cause of alarm
9	Motor failure
2	Photocell in closing
3	Photocell in opening
6	Collision in opening
4	Safety edge

Blinks	Cause of alarm
5	Stop
7	Max. Cycles reached
6	Collision in closing
4 fast	Limit switch fault

TROUBLE SHOOTING

Advices		
Make sure all Safeties are turned ON		
Problem Found	Possible Cause	Solutions
Operator doesn't respond to any START impulse	a) Check the connected N.C. contacts b) Burnt fuse	a) Check the connections or the jumpers on the connections of the safety edge or of the stop and of the photocell if connected b) Replace the burnt fuse on the control unit
Operator does not run and diagnostic display not on.	a) No power to control board b) Open fuse c) Defective control board	a) Check AC power b) Check fuses c) Replace defective control board
Operator does not respond to a wired control/command (example: Open, Close, etc.)	a) Check Open and Close command input b) Stop button is active c) Reset button is stuck d) Entrapment Protection Device active	a) Check all Open and Close inputs for a stuck on input b) Check Stop button is not stuck on c) Check Reset button d) Check all Entrapment Protection Device inputs for a stuck on sensor
Operator does not respond to a transmitter	a) Stop button is active b) Reset button is stuck c) Poor radio reception	a) Check Stop button is not stuck on b) Check Reset button c) Check if similar wired control operates correctly. Check antenna wire
Motor turn only one way	a) Check resistance between motor phase and neutral, if the resistance is MOhm b) Try to invert the motor phase and watch if the motor change or not the direction	a) Change cable b) If the motor is blocked change the cable if the motor go only in one direction the motor relay direction is damaged
Gate doesn't move while the motor is running	a) The motor is in the released position b) There is an obstacle	a) Re-lock the motor b) Remove obstacle
Gate doesn't reach the complete Open / Closed position	a) Wrong setting of the limit switches b) Error on programming c) Gate is stopped by an obstacle d) Torque too low e) Gate is too heavy for automatic slow-down	a) Set limit switches b) Repeat programming c) Remove obstacle d) Increase torque parameter e) Set the slow-down on OFF
Gate opens but doesn't close	a) The contacts of the photocells are connected and open b) The stop contact is connected and open c) The edge contact is open d) Ammeter alarm	a) b) c) Check the jumpers or the connected devices and the signals indicated on the warning lamp d) Check if the ammeter alarm has intervened and eventually increase the torque parameter
Gate doesn't close automatically	a) Pause time set too high b) Control unit in semi-automatic logic	a) Adjust pause time b) Set the pause parameter on a different value from the OFF
Gate moves, but cannot set correct limits	a) Gate does not move to a limit position b) Gate is too difficult to move	a) Use manual disconnect, manually move gate, and ensure gate moves easily limit to limit. Repair gate as needed b) Gate must move easily and freely through its entire range, limit to limit. Repair gate as needed
Gate does not fully open or fully close when setting limits	a) Gate does not move to a limit position b) Gate is too difficult to move	a) Use manual disconnect, manually move gate, and ensure gate moves easily limit to limit. Repair gate as needed b) Gate must move easily and freely through its entire range, limit to limit Repair gate as needed
Gate stops during travel and reverses immediately	a) Control Open/Close becoming active b) The obstacle sensitivity is too low	a) Check all Open and Close inputs for an active input b) Check the obstacle sensitivity value and try to increase this parameter

Advices		
Make sure all Safeties are turned ON		
Problem Found	Possible Cause	Solutions
Gate doesn't respect slow down points	a) ENCODER is not working properly if It's activated b) Mechanical clutch loose c) Slow down space is too wide d) Potentiometer is not working properly if It's activated e) The recovery position parameters are too high or too low	a) Check menu for encoder parameters "Encoder Par" shall be from a low value +/- 10 (gate completely closed) to "Encoder tot" (gate completely opened). If the movement of Ipar is not linear in the range (+/-10 - Encoder tot) probably the Encoder is defective b) Tight mechanical clutch c) Reduce slow down space d) Check menu for potentiometer parameters "IPar" shall be from "I. CH." (gate completely closed) to "I.AP." (gate completely opened). If the movement of Ipar is not linear in the range (I.AP. - I.CH.) probably the potentiometer is defective e) Reduce or increase the recovery position parameters
Gate opens suddenly without start command	a) Frequency or other noise from main line b) Short circuit on the start contact	a) Wiring AC shall be separate from DC wire and pass through separate conduits. If there is a frequency noise it is possible to change frequency to another MHz like 868 for example or FM b) Check all start contacts
Gate doesn't close in automatic logic during pause even if a loop/photo is set as start	a) START IN PAUSE is not in ON b) The photo/loop input is not set as delay pause time	a) Put in ON the menu of START IN PAUSE b) Set in the photo/loop menu (delay pause time)
Gate doesn't have power to close or reach limit switch	a) Slow down not possible for that site due to heavy gate or inclination or not new installation	a) Put Slow Down in OFF
Obstruction in gates path does not cause gate to stop and reverse	a) Force adjustment needed	a) Refer to the Adjustment section to conduct the obstruction test and perform the proper force adjustment that is needed (sensitivity - torque)
Photoelectric sensor does not stop or reverse gate	a) Incorrect photoelectric sensor wiring b) Defective photoelectric sensor c) Photoelectric sensors installed too far apart	a) Check photoelectric sensor wiring. Retest that obstructing photoelectric sensor causes moving gate to stop, and may reverse direction b) Replace defective photoelectric sensor. Retest that obstructing photoelectric sensor causes moving gate to stop, and may reverse direction c) Move the photoelectric sensors closer together or use edge sensors instead
Edge Sensor does not stop or reverse gate	a) Incorrect edge sensor wiring b) Defective edge sensor	a) Check edge sensor wiring. Retest that activating edge sensor causes moving gate to stop and reverse direction b) Replace defective edge sensor. Retest that activating edge sensor causes moving gate to stop and reverse direction
Alarm sounds for 5 minutes or alarm sounds with a command	a) Double entrapment occurred (two obstructions within a single activation)	a) Check for cause of entrapment (obstruction) detection and correct. Press the reset button to shut off alarm and reset the operator.
Shadow loop does not keep gate at the open limit	a) Vehicle detector setup incorrectly b) Defective vehicle loop detector c) Wrong settings	a) Review Shadow loop detector settings. Adjust settings as needed b) Replace defective Shadow loop detector c) Check the photo2 menu is set on shadow loop
Accessories connected to the accessory power not working correctly, turning off or resetting	a) Accessory power protector active b) Defective control board	a) Disconnect all accessory powered devices and measure accessory power voltage (should be 23-30 Vdc). If voltage is correct, connect accessories one at a time, measuring accessory voltage after every new connection b) Replace defective control board
FAILURE 24VAUX	a) Overload or short-circuit on the output N°10 b) Burnt fuse	a) Check a short circuit on the cable b) Change fuse

Page for both instaler and user

MAINTENANCE

Considering the number of working cycles and the kind of gate, if the gate has changed the clutches and doesn't work it's necessary to periodically proceed, with **the learning times reprogramming on the electronic control unit**. Periodically clean the optical systems of the photocells.

REPLACEMENTS

Any request for spare parts must be sent to:

SEA S.p.A. - Zona Ind.le, 64020 S.ATTO - Teramo - Italia

SAFETY AND ENVIRONMENTAL COMPATIBILITY

Disposal of the packaging materials of products and/or circuits should take place in an approved disposal facility.



REGULAR PRODUCT DISPOSAL (electric and electronic waste)

(It's applicable in EU countries and in those ones provided with a differential waste collection)

The brand that you find on the product or on documentation signals that the product must not be disposed off together with other domestic waste at the end of life cycle. In order to avoid any possible environmental or health damage caused by irregular waste disposal, we recommend to separate this product from other forms of waste and to recycle it in a responsible way in order to provide the sustainable re-use of material resources. Domestic users are invited to contact the retailer where the product has been purchased or the local office in charge of all the information related to differential waste collection and recycling of this kind of product.

STORING

WAREHOUSING TEMPERATURES			
T_{min}	T_{Max}	Dampness min	Dampness Max
- 20°C ↴	+ 65°C ↴	5% <i>Not condensing</i>	90% <i>Not condensing</i>

Materials handling must be made with appropriate vehicles..

WARRANTY LIMITS

For the guarantee see the sales conditions on the official SEA price list.

SEA reserves the right to make any required modification or change to the products and/or to this manual without any advanced notice obligation.

English GENERAL NOTICE FOR THE INSTALLER AND THE USER

1. Read carefully these **Instructions** before beginning to install the product. Store these instructions for future reference
2. Don't waste product packaging materials and /or circuits.
3. This product was designed and built strictly for the use indicated in this documentation. Any other use, not expressly indicated here, could compromise the good condition/operation of the product and/or be a source of danger. SEA S.p.A. declines all liability caused by improper use or different use in respect to the intended one.
4. The mechanical parts must be comply with Directives: Machine Regulation 2006/42/CE and following adjustments), Low Tension (2006/95/CE), electromgnetic Consistency (2004/108/CE) Installation must be done respecting Directives: EN12453 and En12445.
5. Do not install the equipment in an explosive atmosphere.
6. SEA S.p.A. is not responsible for failure to observe Good Techniques in the construction of the locking elements to motorize, or for any deformation that may occur during use.
7. Before attempting any job on the system, cut out electrical power and disconnect the batteries. Be sure that the earthing system is perfectly constructed, and connect it metal parts of the lock.
8. Use of the indicator-light is recommended for every system, as well as a warning sign well-fixed to the frame structure.
9. SEA S.p.A. declines all liability as concerns the automated system's security and efficiency, if components used, are not produced by SEAS.p.A..
10. For maintenance, strictly use original parts by SEA.
11. Do not modify in any way the components of the automated system.
12. The installer shall supply all information concerning system's manual functioning in case of emergency, and shall hand over to the user the warnings handbook supplied with the product.
13. Do not allow children or adults to stay near the product while it is operating. The application cannot be used by children, by people with reduced physical, mental or sensorial capacity, or by people without experience or necessary training. Keep remote controls or other pulse generators away from children, to prevent involuntary activation of the system.
14. Transit through the leaves is allowed only when the gate is fully open.
15. The User must not attempt to repair or to take direct action on the system and must solely contact qualified SEA personnel or SEA service centers. User can apply only the manual function of emergency.
16. The power cables maximum length between the central engine and motors should not be greater than 10 m. Use cables with 2,5 mm² section. Use double insulation cable (cable sheath) to the immediate vicinity of the terminals, in particular for the 230V cable. Keep an adequate distance (at least 2.5 mm in air), between the conductors in low voltage (230V) and the conductors in low voltage safety (SELV) or use an appropriate sheath that provides extra insulation having a thickness of 1 mm.

TERMS OF SALES

EFFICACY OF THE FOLLOWING TERMS OF SALE: the following general terms of sale shall be applied to all orders sent to SEA S.p.A. All sales made by SEA to all costumers are made under the prescription of this terms of sales which are integral part of sale contract and cancel and substitute all apposed clauses or specific negotiations present in order document received from the buyer.

GENERAL NOTICE The systems must be assembled exclusively with SEA components, unless specific agreements apply. Non-compliance with the applicable safety standards (European Standards EM12453 – EM 12445) and with good installation practice releases SEA from any responsibilities. SEA shall not be held responsible for any failure to execute a correct and safe installation under the above mentioned standards.

1) PROPOSED ORDER The proposed order shall be accepted only prior SEA approval of it. By signing the proposed order, the Buyer shall be bound to enter a purchase agreement, according to the specifications stated in the proposed order.

On the other hand, failure to notify the Buyer of said approval must not be construed as automatic acceptance on the part of SEA.

2) PERIOD OF THE OFFER The offer proposed by SEA or by its branch sales department shall be valid for 30 solar days, unless otherwise notified.

3) PRICING The prices in the proposed order are quoted from the Price List which is valid on the date the order was issued. The discounts granted by the branch sales department of SEA shall apply only prior to acceptance on the part of SEA. The prices are for merchandise delivered ex-works from the SEA establishment in Teramo, not including VAT and special packaging. SEA reserves the right to change at any time this price list, providing timely notice to the sales network. The special sales conditions with extra discount on quantity basis (Qx, Qx1, Qx2, Qx3 formula) is reserved to official distributors under SEA management written agreement.

4) PAYMENTS The accepted forms of payment are each time notified or approved by SEA. The interest rate on delay in payment shall be 1.5% every month but anyway shall not be higher than the max. interest rate legally permitted.

5) DELIVERY Delivery shall take place, approximately and not peremptorily, within 30 working days from the date of receipt of the order, unless otherwise notified. Transport of the goods sold shall be at Buyer's cost and risk. SEA shall not bear the costs of delivery giving the goods to the carrier, as chosen either by SEA or by the Buyer. Any loss and/or damage of the goods during transport, are at Buyer's cost.

6) COMPLAINTS Any complaints and/or claims shall be sent to SEA within 8 solar days from receipt of the goods, proved by adequate supporting documents as to their truthfulness.

7) SUPPLY The concerning order will be accepted by SEA without any engagement and subordinately to the possibility to get it's supplies of raw material which is necessary for the production; Eventual completely or partially unsuccessful executions cannot be reason for complains or reservations for damage. SEA supply is strictly limited to the goods of its manufacturing, not including assembly, installation and testing. SEA, therefore, disclaims any responsibility for damage deriving, also to third parties, from non-compliance of safety standards and good practice during installation and use of the purchased products.

8) WARRANTY The standard warranty period is 12 months. This warranty time can be extended by means of expedition of the warranty coupon as follows:

SILVER: The mechanical components of the operators belonging to this line are guaranteed for 24 months from the date of manufacturing written on the operator.

GOLD: The mechanical components of the operators belonging to this line are guaranteed for 36 months from the date of manufacturing written on the operator.

PLATINUM: The mechanical components of the operators belonging to this line are guaranteed for 36 months from the date of manufacturing written on the operator. The base warranty (36 months) will be extended for further 24 months (up to a total of 60 months) when it is acquired the certificate of warranty which will be filled in and sent to SEA S.p.A. The electronic devices and the systems of command are guaranteed for 24 months from the date of manufacturing. In case of defective product, SEA undertakes to replace free of charge or to repair the goods provided that they are returned to SEA repair centre. The definition of warranty status is by unquestionable assessment of SEA. The replaced parts shall remain propriety of SEA. Binding upon the parties, the material held in warranty by the Buyer, must be sent back to SEA repair centre with fees prepaid, and shall be dispatched by SEA with carriage forward. The warranty shall not cover any required labour activities.

The recognized defects, whatever their nature, shall not produce any responsibility and/or damage claim on the part of the Buyer against SEA. The guarantee is in no case recognized if changes are made to the goods, or in the case of improper use, or in the case of tampering or improper assembly, or if the label affixed by the manufacturer has been removed including the SEA registered trademark No. 804888. Furthermore, the warranty shall not apply if SEA products are partly or completely coupled with non-original mechanical and/or electronic components, and in particular, without a specific relevant authorization, and if the Buyer is not making regular payments. The warranty shall not cover damage caused by transport, expendable material, faults due to non-conformity with performance specifications of the products shown in the price list. No indemnification is granted during repairing and/or replacing of the goods in warranty. SEA disclaims any responsibility for damage to objects and persons deriving from non-compliance with safety standards, installation instructions or use of sold goods. The repair of products under warranty and out of warranty is subject to compliance with the procedures notified by SEA.

9) RESERVED DOMAIN A clause of reserved domain applies to the sold goods; SEA shall decide autonomously whether to make use of it or not, whereby the Buyer purchases propriety of the goods only after full payment of the latter.

10) COMPETENT COURT OF LAW In case of disputes arising from the application of the agreement, the competent court of law is the tribunal of Teramo. SEA reserves the faculty to make technical changes to improve its own products, which are not in this price list at any moment and without notice. SEA declines any responsibility due to possible mistakes contained inside the present price list caused by printing and/or copying. The present price list cancels and substitutes the previous ones. The Buyer, according to the law No. 196/2003 (privacy code) consents to put his personal data, deriving from the present contract, in SEA archives and electronic files, and he also gives his consent to their treatment for commercial and administrative purposes.

Industrial ownership rights: once the Buyer has recognized that SEA has the exclusive legal ownership of the registered SEA brand num.804888 affixed on product labels and / or on manuals and / or on any other documentation, he will commit himself to use it in a way which does not reduce the value of these rights, he won't also remove, replace or modify brands or any other particularity from the products. Any kind of replication or use of SEA brand is forbidden as well as of any particularity on the products, unless preventive and expressed authorization by SEA.

In accomplishment with art. 1341 of the Italian Civil Law it will be approved expressly clauses under numbers:

4) PAYMENTS - 8) GUARANTEE - 10) COMPETENT COURT OF LAW



Dichiarazione di conformità
Declaration of Conformity

La SEA S.p.A. dichiara che, con l'installazione degli adeguati dispositivi di sicurezza e di filtraggio disturbi, il prodotto:

SEA S.p.A. declares that by installing the appropriate safety equipment and noise filtering the product:

Descrizione / Description	Modello / Model	Marca / Trademark
GATE 1 DG R2BF (e tutti i suoi derivati)	23001158	SEA
<i>GATE 1 DG R2BF (and all its by-products)</i>	<i>23001158</i>	<i>SEA</i>

è costruito per essere incorporato in una macchina o per essere assemblato con altri macchinari per costruire una macchina ai sensi della Direttiva 2006/42/CE:

is built to be integrated into a machine or to be assembled with other machinery to create a machine under the provisions of Directive 2006/42/CE:

è conforme ai requisiti essenziali di sicurezza relativi al prodotto entro il campo di applicabilità delle Direttive Comunitarie 2006/95/CE e 2004/108/CE.

It is conforming to the essential safety requirements related to the product within the field of applicability of the Community Directives 2006/95/CE and 2004/108/CE.

COSTRUTTORE o RAPPRESENTANTE AUTORIZZATO:
MANUFACTURER or AUTHORISED REPRESENTATIVE:

SEAS.p.A.
DIREZIONE E STABILIMENTO:
Zona industriale 64020 S.ATTO Teramo - (ITALY)
Tel. +39 0861 588341 r.a. Fax +39 0861 588344
[Http://www.seateam.com](http://www.seateam.com)

I test sul prodotto sono stati effettuati in configurazione standard e in riferimento alle norme specifiche per la sua classe d'utilizzo.

The products have been tested in standard configuration and with reference to the special norms concerning the classe of use.

Luogo, data di emissione
Place, date of issue
Teramo, 21/04/2015

L'Administratore
The Administrator
Eugenio Di Savarino



Questo articolo è stato prodotto seguendo rigide procedure di lavorazione ed è stato testato singolarmente al fine di garantire i più alti livelli qualitativi e la vostra soddisfazione. Vi ringraziamo per aver scelto SEA.

This item has been produced following strict production procedures and has been singularly tested for the highest quality levels and for your complete satisfaction.
Thanks for choosing SEA.

Cet article a été produit suivant des procédures d'usinage strictes et il a singulièrement été testé afin de garantir les plus hauts niveaux de qualité pour votre satisfaction.
Nous vous remercions d'avoir choisi SEA.

Este artículo ha sido producido siguiendo rigidos procedimientos de elaboración y ha sido probando singolarmente a fin de garantizar los mas altos niveles de calidad y vuestra satisfaccion.
Le agradecemos por haber escogito SEA.

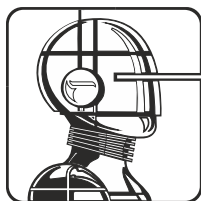

SEA[®]

Sistemi Elettronici
di Apertura Porte e Cancelli
International registered trademark n. 804888



SEA S.p.A.
Zona industriale 64020 S.ATTO Teramo - (ITALY)
Tel. +39 0861 588341 r.a. Fax +39 0861 588344

www.seateam.com

seacom@seateam.com