



IS102 Rev.03 03/10/2016

B70/2DCHP

centrale di comando per cancelli battenti

Istruzioni originali

ROGER
BRUSHLESS



- IT - Istruzioni ed avvertenze per l'installatore - pag. 11
- EN - Instructions and warnings for the installer - pag. 37
- DE - Anweisungen und Hinweise für den Installateur - S. 63
- FR - Instructions et consignes pour l'installateur - p. 89
- ES - Instrucciones y advertencias para el instalador - pág. 115
- PT - Instruções e advertências para o instalador - pág. 141

ROGER
TECHNOLOGY
AUTOMAZIONI EVOLUTE

IT	1	Avvertenze generali	11	FR	1	Consignes générales de sécurité	89		
	2	Descrizione prodotto	11		2	Description produit	89		
	3	Caratteristiche tecniche prodotto	12		3	Caractéristiques techniques produit	90		
	4	Descrizione dei collegamenti	12		4	Description des raccordements	90		
	4.1	Collegamenti elettrici	13		4.1	Branchements électriques	91		
	5	Tasti funzione e display	14		5	Touches fonction et écran	92		
	6	Accensione o messa in servizio	14		6	Allumage ou mise en service	92		
	7	Modalità funzionamento display	15		7	Modalités fonctionnement écran	93		
	8	Apprendimento della corsa	17		8	Apprentissage de la course	95		
	9	Indice dei parametri	18		9	Indice des paramètres	96		
	10	Menù parametri	20		10	Menu paramètres	98		
	11	Comandi e accessori	30		11	Commandes et accessoires	108		
	12	Segnalazione degli ingressi di sicurezza e dei comandi (modalità TEST)	32		12	Signalisation des entrées de sécurité et des commandes (modalités TEST)	110		
	13	Segnalazione allarmi e anomalie	33		13	Signalisations alarmes et anomalies	111		
	14	Modalità INFO	34		14	Diagnostic - Modalité info	112		
	15	Sblocco meccanico	35		15	Déblocage mécanique	113		
	16	Modalità di recupero posizione	35		16	Modalités de récupération position	113		
	17	Collaudo	35		17	Test	113		
	18	Manutenzione	35		18	Entretien	113		
	19	Smaltimento	35		19	Élimination	113		
	20	Informazioni aggiuntive e contatti	36		20	Informations complémentaires et contacts	114		
	21	Dichiarazione di Conformità	36		21	Déclaration de conformité	114		
	EN	1	General safety precautions		37	ES	1	Advertencias generales	115
		2	Product description		37		2	Descripción del producto	115
3		Technical characteristics of product	38	3	Características técnicas del producto		116		
4		Description of connections	38	4	Descripción de las conexiones		116		
4.1		Electrical connections	39	4.1	Conexiones eléctricas		117		
5		Function buttons and display	40	5	Teclas de función y pantalla		118		
6		Switching on or commissioning	40	6	Encendido o puesta en servicio		118		
7		Display function modes	41	7	Modo de funcionamiento de la pantalla		119		
8		Travel acquisition	43	8	Aprendizaje del recorrido		121		
9		Index of parameters	44	9	Índice de los parámetros		122		
10		Parameters menu	46	10	Menú de parámetros		124		
11		Commands and Accessories	56	11	Comandos y accesorios		134		
12		Safety input and command status (TEST mode)	58	12	Señalización de las entradas de seguridad y de los comandos (Modo TEST)		136		
13		Alarms and faults	59	13	Señalización de alarmas y anomalías		137		
14		Procedural verifications - INFO Mode	60	14	Diagnostica - Modo Info		138		
15		Mechanical release	61	15	Desbloqueo mecánico		139		
16		Position recovery mode	61	16	Modo de recuperación de la posición		139		
17		Initial testing	61	17	Ensayo		139		
18		Maintenance	61	18	Mantenimiento		139		
19		Disposal	61	19	Eliminación		139		
20		Additional information and contact details	62	20	Información adicional y contactos		140		
21		Declaration of Conformity	62	21	Declaración de Conformidad		140		
DE		1	Allgemeine Sicherheitshinweise	63	PT		1	Advertências gerais	141
		2	Produktbeschreibung	63			2	Descrição do produto	141
	3	Technische Daten des Produkts	64	3		Caraterísticas técnicas do produto	142		
	4	Beschreibung der Anschlüsse	64	4		Descrição das ligações	142		
	4.1	Elektrische Anschlüsse	65	4.1		Ligações elétricas	143		
	5	Funktionstasten und Display	66	5		Teclas de função e display	144		
	6	Einschalten oder Inbetriebnahme	66	6		Ignição ou comissionamento	144		
	7	Funktion Display	67	7		Modalidade de funcionamento do display	145		
	8	Lernlauf	69	8		Aprendizagem do curso	147		
	9	Index der Parameter	70	9		Índice dos parâmetros	148		
	10	Menü Parameter	72	10		Menu dos parâmetros	150		
	11	Befehle und Zubehör	82	11		Comandos e acessórios	160		
	12	Meldung der Sicherheitseingänge und der Befehle (TEST-Modus)	84	12		Sinalização das entradas de segurança e dos comandos (modalidade TEST)	162		
	13	Meldung von Alarmen und Störungen	85	13		Sinalização de alarmes e anomalias	163		
	14	Diagnostik - Betriebsart Info	86	14		Diagnosticar - Modo INFO	164		
	15	Mechanische Entriegelung	87	15		Desbloqueio mecânico	165		
	16	Modus zur Korrektur der Position	87	16		Modalidade de recuperação de posição	165		
	17	Abnahmeprüfung	87	17		Teste	165		
	18	Wartungsarbeiten	87	18		Manutenção	165		
	19	Entsorgung	87	19		Descarte	165		
	20	Zusätzliche Informationen und Kontakte	88	20		Informações adicionais e contatos	166		
	21	Konformitätserklärung	88	21		Declaração de conformidade	166		



IT

Questa versione contiene miglioramenti, ed include importanti aggiornamenti relativi alla sicurezza. Rispetto alla r1.04 l'attuale versione si differenzia per:

- Nuova grafica del manuale
- Eliminata modalità semplificata dei parametri.
- Aggiunti parametri
 1. *R1 05*: selezione pistone tipo SMARTY Irreversibile;
 2. *40 04* e *41 04*: regolazione della velocità in apertura e chiusura;
 3. *B1 02*: abilitazione della chiusura/apertura garantita;
- Introdotta Modalità Info;
- Ottimizzata la procedura di recupero posizione;
- Ottimizzata la gestione dell'elettroserratura (nuovo par. *2B*, aggiunto valore *02* a par. *29*);
- Aggiunta modalità di gestione manutenzione (par. *B6* e *B7*);
- Aggiunta gestione errore "SECC".

EN

This version introduces improvements, and includes important new content regarding safety. The latest version differs from the previous version r1.04 as follows:

- New manual graphics
- Eliminated simplified parameter mode.
- Added parameters
 1. *R1 05*: SMARTY piston selection;
 2. *40 04* and *41 04*: open/close speed setting;
 3. *B1 02*: enable safeguarded door closure/opening;
- Introduced Info Mode.
- Position recovery procedure optimised
- Electric lock management optimised (new par. *2B*, value *02* added in par. *29*)
- Maintenance management mode added (par. *B6* and *B7*)
- "SECC" error management added

DE

Diese Version enthält Verbesserungen und umfasst wichtige Neuerungen zur Sicherheit. Im Vergleich zur r1.04 unterscheidet sich die aktuelle Version durch:

- Neue Grafik des Handbuchs
- Vereinfachter Modus der Parameter abgeschafft.
- Hinzugefügte Parameter
 1. *R1 05*: Auswahl Kolben vom Typ SMARTY;
 2. *40 04* und *41 04*: Einstellung der Geschwindigkeit beim Öffnen und Schließen;
 3. *B1 02*: Aktivierung der garantierten Schließung/Öffnung;
- Info-Modus eingeführt.
- Optimiertes Verfahren zur Korrektur der Position
- Optimierte Verwaltung des Elektroschlusses (neu Abschn. *2B*, hinzugefügter Wert *02* in Abschn. *29*)
- Hinzugefügter Modus Instandhaltungsmanagement (Abschn. *B6* und *B7*)
- Hinzugefügtes Fehlermanagement "SECC".

FR

Cette version contient des améliorations et inclut d'importantes mises à jour sur la sécurité. Par rapport à la r1.04, cette version se distingue par :

- une nouvelle mise en page du manuel ;
- une suppression de la modalité simplifiée des paramètres ;
- un ajout de paramètres.
 1. *R1 05* : sélection piston type SMARTY ;
 2. *40 04* et *41 04* : réglage de la vitesse en ouverture et fermeture ;
 3. *B1 02* : activation de la fermeture/ouverture garantie;
- Introduction de la modalité Info.
- Optimisation de la procédure de récupération de position
- Optimisation de la gestion de l'électroserrure (nouveau par. *2B*, valeur *02* ajoutée au par. *29*)
- Ajout de la modalité de gestion d'entretien (par. *B6* et *B7*)
- Ajout de la gestion erreur « SECC »

ES

Esta versión contiene algunas mejoras, actualizando asimismo varios aspectos concernientes a la seguridad. Con respecto a la r1.04 la versión actual se diferencia por lo siguiente:

- Nueva gráfica del manual
- Se ha eliminado el modo simplificado de los parámetros.
- Se han añadido otros parámetros
 1. *R1 05*: selección del pistón de tipo SMARTY;
 2. *40 04* y *41 04*: regulación de la velocidad de apertura y cierre;
 3. *B1 02*: habilitación garantizada del cierre y de la apertura;
- Se ha introducido el Modo Info.
- Se ha optimizado el procedimiento de recuperación de la posición
- Se ha optimizado la gestión de la electrocerradura (nuevo apart. *2B*, se ha añadido el valor *02* en el apart. *29*)
- Se ha añadido el modo de gestión del mantenimiento (apart. *B6* y *B7*)
- Se ha añadido la gestión del error "SECC"

PT

Esta versão contém melhorias e inclui atualizações de segurança importantes.

As diferenças da versão r1.04 com a atual são:

- Nova gráfica do manual
- Modo simplificado dos parâmetros eliminado.
- Foram adicionados parâmetros
 1. *R1 05*: seleção do pistão do tipo SMARTY;
 2. *40 04* e *41 04*: ajuste da velocidade em abertura e fecho;
 3. *B1 02*: habilitação do fecho/abertura garantida;
- Modo Info introduzida.
- Foi otimizado o processo de recuperação da posição
- Foi otimizada a gestão da fechadura elétrica (novo par. *2B*, adicionado valor *02* ao par. *29*).
- Foi adicionado o modo de gestão de manutenção (par. *B6* e *B7*).
- Foi adicionada a gestão do erro "SECC".

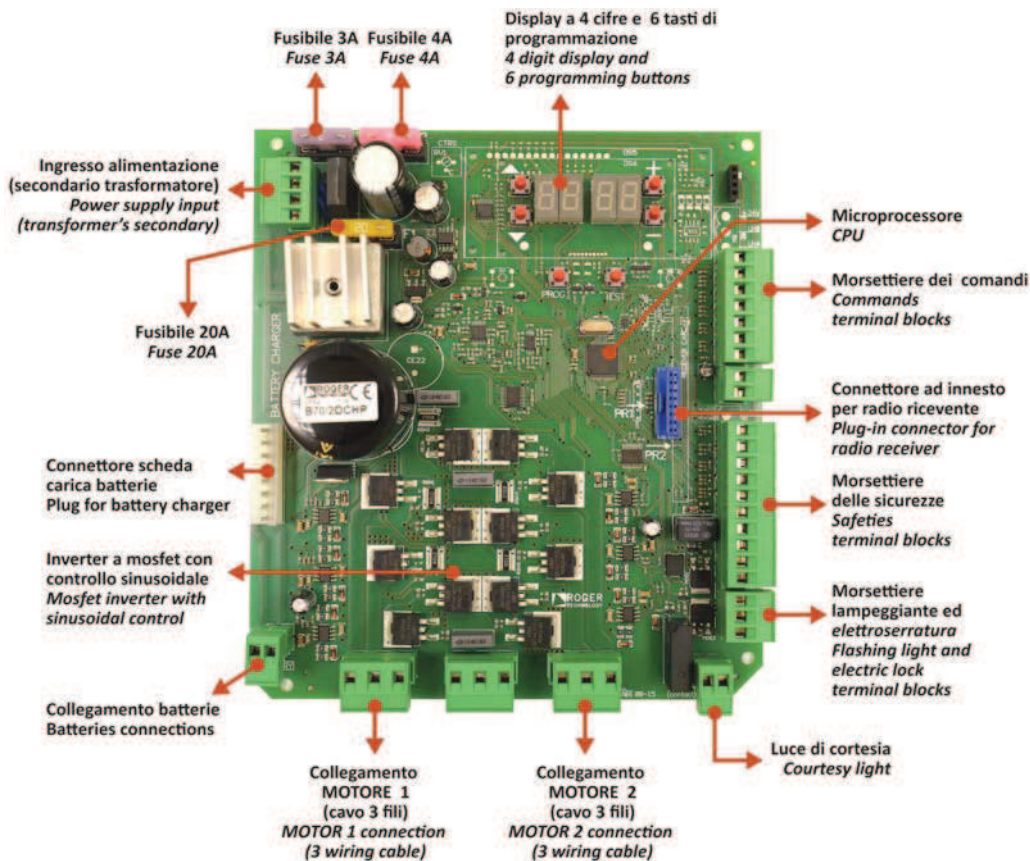

Firmware Rev r2.00

1

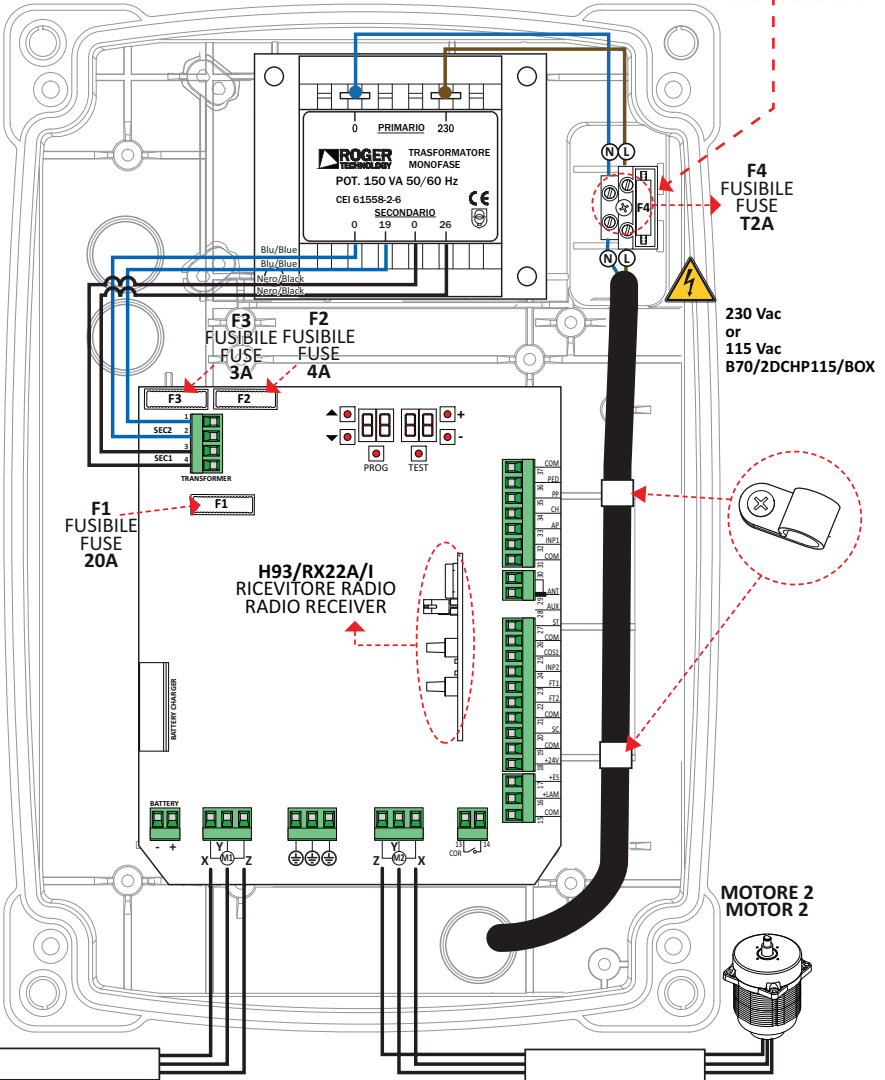
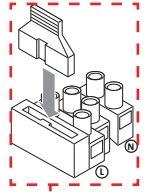

MOTORE 1
MOTOR 1

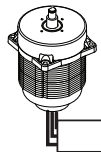

MOTORE 2
MOTOR 2

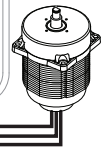

2

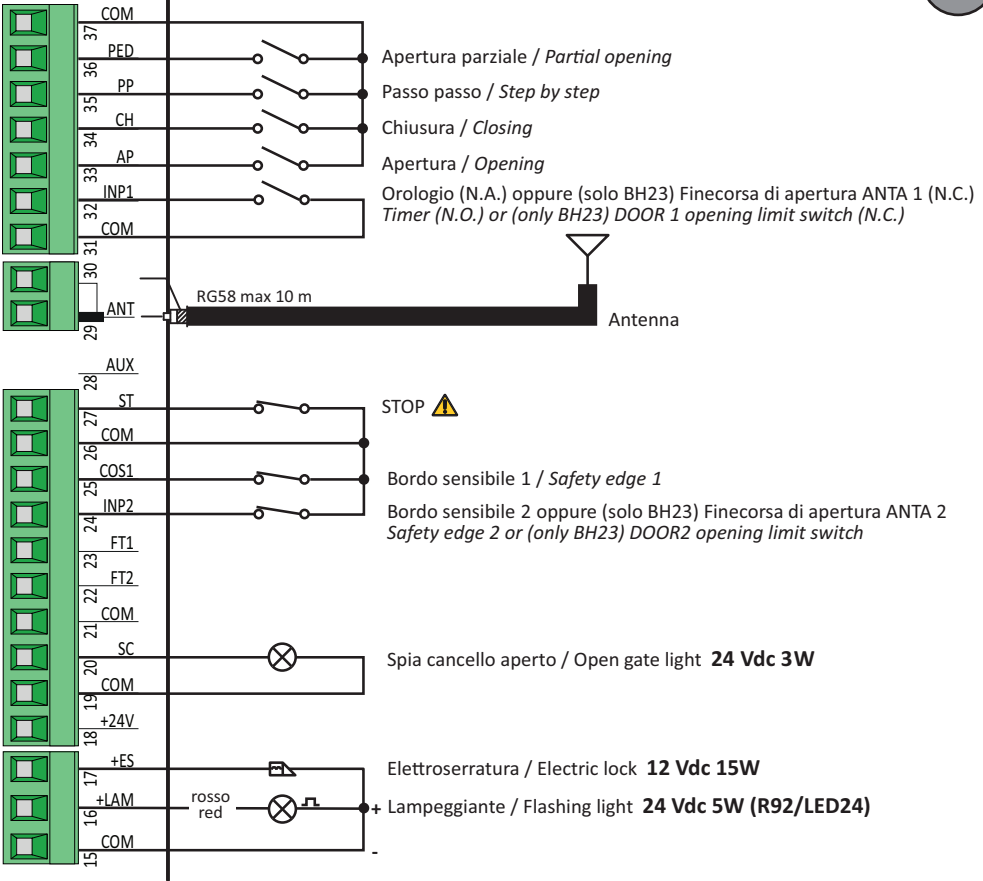

3

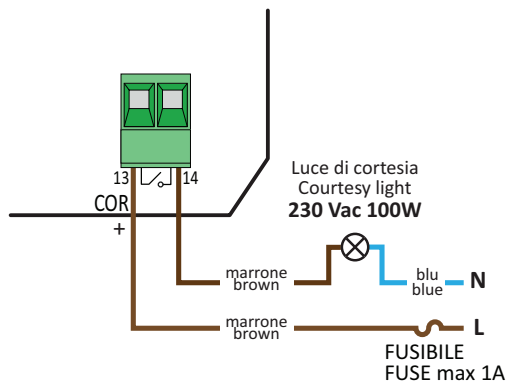

4

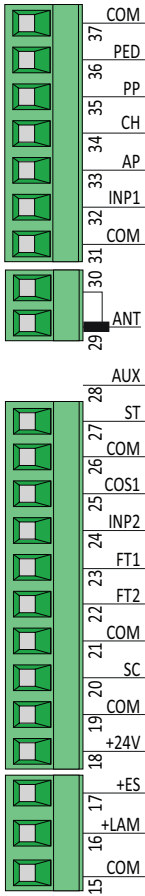

**R90/F4ES
G90/F4ES
T90/F4S**



**USO RACCOMANDATO
RECOMMENDED USE**

FT1

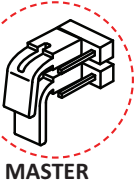
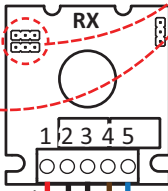
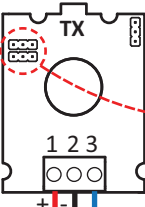

FT2

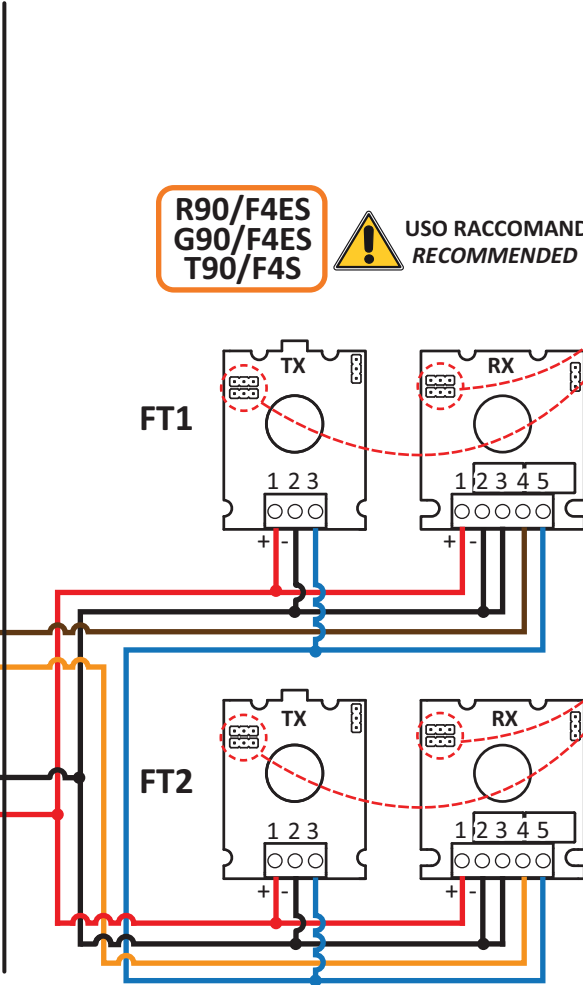
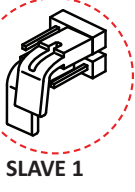
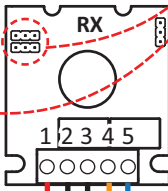
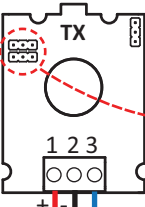

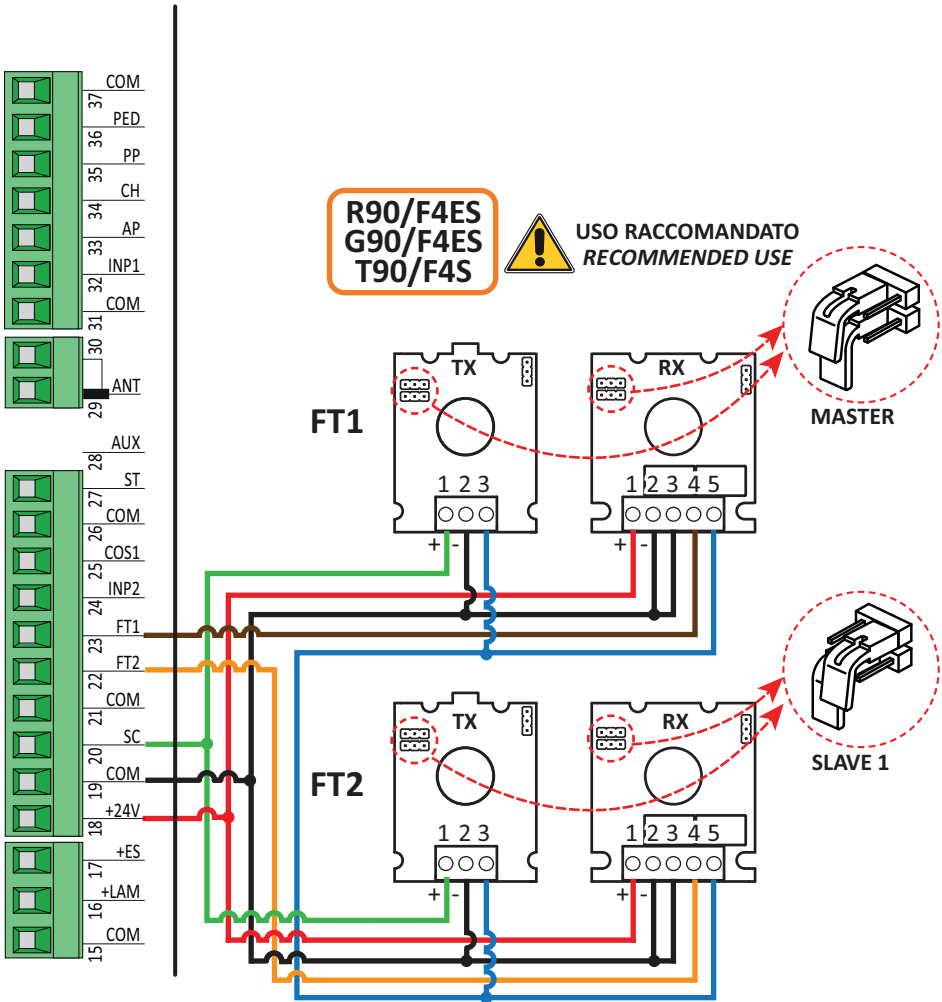

6

BATTERY SAVING (impostare / set *AB 03*)

BATTERY SAVING + TEST FOTOCELLULE / PHOTOCELLS TEST
(impostare / set *AB 04*)

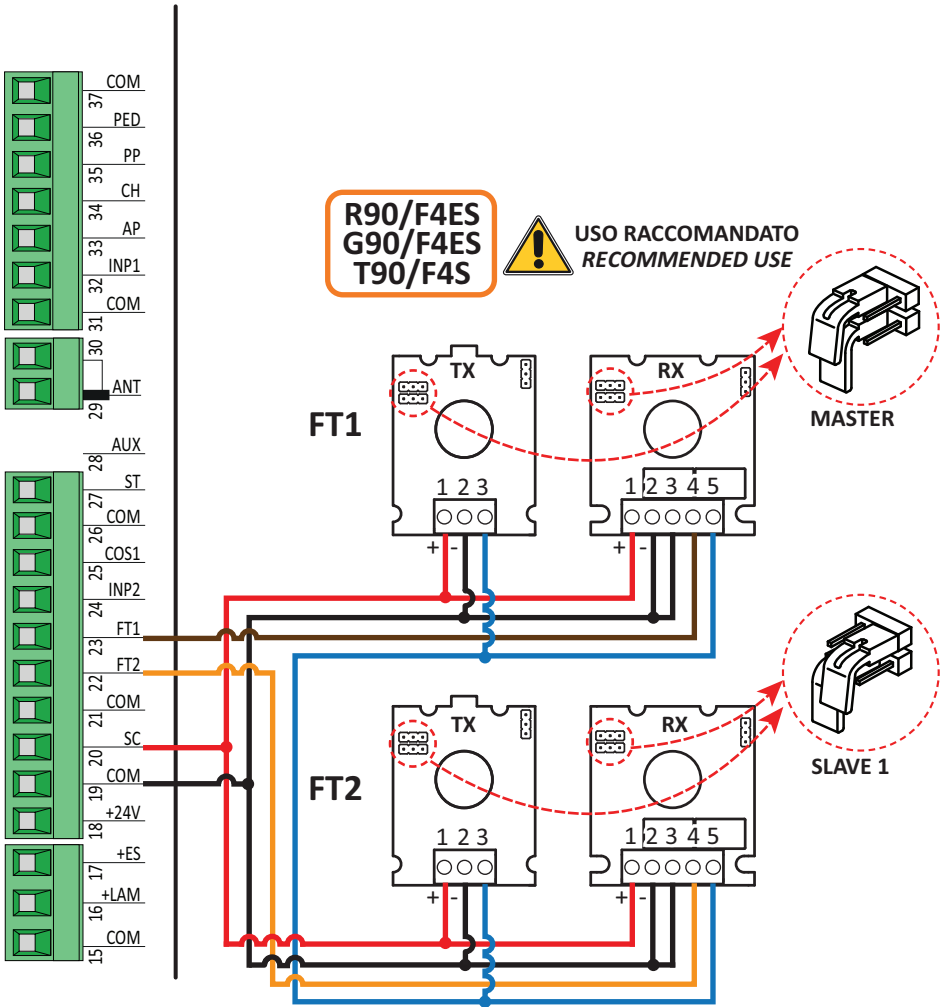

1 General safety precautions



Warning: incorrect installation may cause severe damage or injury.

Read the instructions carefully before installing the product.

This installation manual is intended for qualified personnel only.

ROGER TECHNOLOGY cannot be held responsible for any damage or injury due to improper use or any use other than intended usage indicated in this manual.

Installation, electrical connections and adjustments must be performed by qualified personnel, in accordance with best practices and in compliance with applicable regulations.



Before installing the product, make sure it is in perfect condition.

A switch or an omnipolar cut-off switch with a contact opening of at least 3 mm must be installed on the mains power line.

Ensure that an adequate residual current circuit breaker and a suitable overcurrent cut-out are installed ahead of the electrical installation in accordance with best practices and in compliance with applicable legislation.

The European standards EN 12453 and EN 12445 define the minimum safety requirements for the operation of automatic doors and gates. In particular, these standards require the use of force limiting and safety devices (sensing ground plates, photocell barriers, operator detection function etc.) intended to detect persons or objects in the operating area and prevent collisions in all circumstances.

Where the safety of the installation is based on an impact force limiting system, it is necessary to verify that the characteristics and performance of the automation system are compliant with the requisites of applicable standards and legislation.

The installer is required to measure impact forces and programme the control unit with appropriate speed and torque values to ensure that the door or gate remains within the limits defined by the standards EN 12453 and EN 12445.

Ensure that an adequate residual current circuit breaker and a suitable overcurrent cut-out are installed ahead of the electrical installation in accordance with best practices and in compliance with applicable legislation.

When requested, connect the automation to an effective earthing system that complies with current safety standards.

Disconnect the mains electrical power before performing any work. Also disconnect any buffer batteries used.

Only use original spare parts when repairing or replacing products.

The packaging materials (plastic, polystyrene, etc.) should not be discarded in the environment or left within reach of children, as they are a potential source of danger.

2 Product description

The 36 V **B70/2DCHP** control unit controls 1 or 2 ROGER brushless motors in sensorless mode for applications on large sized or heavy gate wings.



Ensure that the parameter A1 is set correctly. If this parameter is not set correctly, the automation system may not function properly.

Use the same type of motor for both gate leaves in automation installations for double leaf swing gates.

Adjust the opening and closure speed, deceleration and delay settings appropriately for the specific installation, ensuring that the gate leaves overlap correctly.

We recommend using only ROGER TECHNOLOGY accessories and control and safety devices. Specifically, we recommend installing **R90/F4ES**, **G90/F4ES** or **T90/F4S** series photocells.

3 Technical characteristics of product

	B70/2DCHP/BOX	B70/2DCHP115/BOX
MAINS POWER VOLTAGE	230 Vac \pm 10% 50 Hz	115 Vac \pm 10% 60 Hz
MAXIMUM MAINS POWER ABSORPTION	600 W	
FUSES	F1 = 20A (ATO257) motor power circuit protection. F2 = 4A (ATO257) accessories power supply protection F3 = 3A (ATO257) electric lock protection F4 = T2A (5x20 mm) primary transformer coil protection	
CONNECTABLE MOTORS	2	
MOTOR POWER SUPPLY	36 Vac , with self-protected inverter	
MOTOR TYPE	sinusoidal drive brushless (ROGER BRUSHLESS)	
MOTOR CONTROL TYPE	sensorless field oriented control (FOC)	
RATED MOTOR POWER	60 W	
MAXIMUM MOTOR POWER	250 W	
MAXIMUM POWER, FLASHING LIGHT	25 W (24 Vdc)	
FLASHING LIGHT DUTY CYCLE	50%	
MAXIMUM POWER	100 W 230 Vac - 40 W 24 Vac/dc (potential free contact)	
GATE OPEN LIGHT POWER	3 W (24 Vdc)	
ELECTRIC LOCK POWER	15 W (12 Vdc)	
MAXIMUM ACCESSORY CURRENT ABSORPTION	10 W (24 Vdc)	
OPERATING TEMPERATURE	 -20°C  +55°C	
DEGREE OF PROTECTION	IP54	
PRODUCT DIMENSION	dimensions in mm 330x230x115 Weight: 3,9 kg	

4 Description of connections

Figure 1 shows connection diagrams.

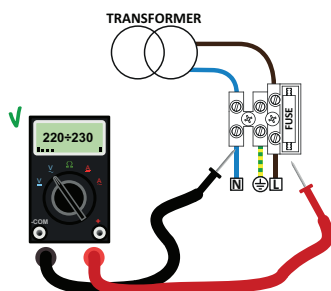

Measure the voltage on the primary mains power connection with a tester.

For the Brushless automation system to function correctly, the mains power voltage must be at least 230Vac (115 Vac) \pm 10%.

If the voltage measured is not as indicated above or is unstable, the automation system may not work correctly.

4.1 Electrical connections

CONNECTING CONTROL UNIT TO MAINS ELECTRICITY	L cable	
	1±15 m	15±30 m
Power supply 230 Vac ±10% (115 Vac ±10% B70/2DCHP115/BOX)	3x1,5 mm ²	3x2,5 mm ²

CONNECTING CONTROL PANEL TO MOTORS	L cable	
	1±10 m	10±30 m
Motor 1	3x2,5 mm ²	3x4 mm ²
Motor 2	3x2,5 mm ²	3x4 mm ²

CONNECTING CONTROL PANEL TO ACCESSORIES	L cable = 1±20 m
Photocells - Receiver	4x0,5 mm ²
Photocells - Transmitter	2x0,5 mm ²
Keypad H85/TDS - H85/TTD (connecting to control panel to decoder board H85/DEC)	3x0,5 mm ²
Key selector R85/60	3x0,5 mm ²

CONNECTING CONTROL PANEL TO FLASHING LIGHT	L cable
Power supply 24 Vdc by LED (25 W power - Duty cycle 50%)	2x1 mm ² (max 10 m)

CONNECTING CONTROL PANEL TO ACCESSORIES	L cable
	1±20 m
Power supply 24 Vdc (3 W max)	2x0,5 mm ²

CONNECTING CONTROL PANEL TO COURTESY LIGHT	L cable
	1±20 m
Power supply 230 Vac (100 W)	2x1 mm ²

CONNECTING CONTROL PANEL TO ANTENNA	L cable
Cable type RG58	max 10 m

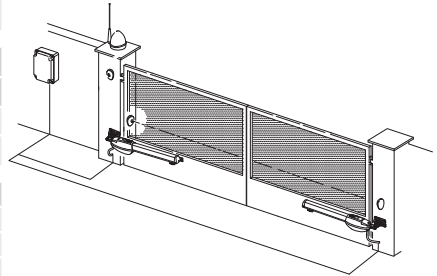

SUGGESTIONS: in the case of a new installation, we recommend using cables with a cross section of 3x2.5 mm² and not exceeding 10 m in length to connect the motor with the control unit.

With existing installations, we recommend checking the cross section of the cables and that the cables themselves are in good condition.

WARNING: old cables or previous generation cables, especially if with a cross section of 3x1.5mm², may impair the performance of the digital brushless motor.

	DESCRIPTION
	Mains power supply 230 Vac ±10% 50 Hz connection. (B70/2DCHP115/BOX : 115 Vac ± 10% 60Hz). Fuse 5x20 T2A.
	Secondary transformer input for 26 V AC motor power (SEC1) and for 19 V power to logical control and peripheral devices (SEC2). N.B.: Ready wired in factory by ROGER TECHNOLOGY.
X-Y-Z 	Connection to ROGER brushless MOTOR 1. Warning! If the motor rotates in the wrong direction, simply swap any two of the three motor connectors. Check the connections illustrated in fig. 1.
Z-Y-X 	Connection to ROGER brushless MOTOR 2. Warning! If the motor rotates in the wrong direction, simply swap any two of the three motor connectors. Check the connections illustrated in fig. 1.
BATTERY 	Connection to B71/BCHP (see fig. 7) See instructions for B71/BCHP for further information.

5 Function buttons and display

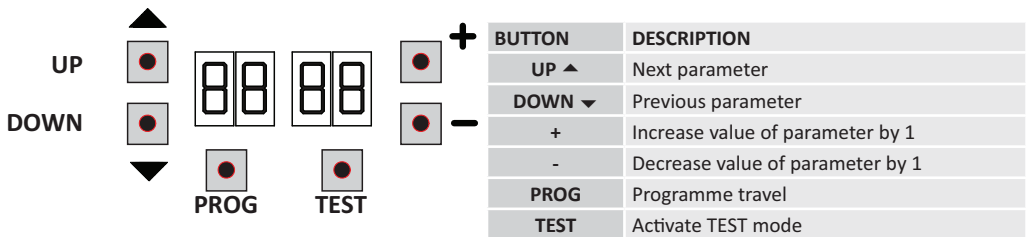

- Press the UP ▲ and/or DOWN ▼ buttons to view the parameter you intend to modify.
- Use the + and - buttons to modify the value of the parameter. The value starts to flash.
- Press and hold the + or - button to scroll quickly through values, to modify the parameter more quickly.
- To save the new value, wait a few seconds or move onto another parameter with the UP ▲ or DOWN ▼ button. The display flashes rapidly to indicate that the new value has been saved.
- Parameters can only be modified while the motor is not running. Parameters can be viewed at any time.

6 Switching on or commissioning

Power the control unit.

The firmware version of the control unit is displayed briefly.

Version installed: r2.00.

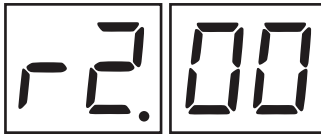

Immediately afterwards, the displays enters the commands and safety device status mode. See chapter 7.

7 Display function modes

7.1 Parameter display mode

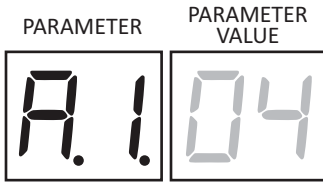

See chapter 10 for detailed descriptions of the parameters.

7.2 Command and safety device status display mode

BM20 - BR20 - BR21 - SMARTY Series

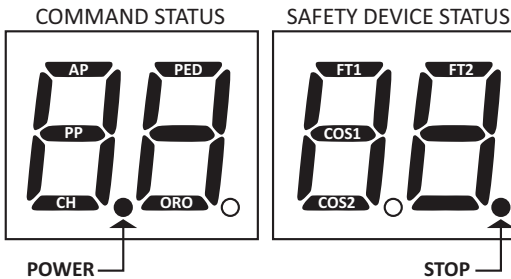

in alarm state or is not connected.

The an indicator is flashing, the relative device has been disabled with a specific parameter.

COMMAND STATUS:

The command status indicators on the display (segments **AP** = open, **PP** = step mode, **CH** = close, **PED** = partial opening, **ORO**= clock) are normally off. They illuminate when a command is received (e.g.: when a step mode command is received, the segment **PP** illuminates).

SAFETY DEVICE STATUS:

The safety device status indicators on the display (segments **FT1/FT2**=photocells, **COS1/COS2** = sensing edges, **STOP**) are normally on. If an indicator is off, the relative device is

BH23 Serie

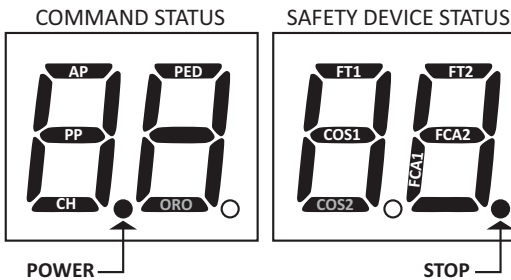

normally on. If an indicator is off, the relative device is in alarm state or is not connected.

The an indicator is flashing, the relative device has been disabled with a specific parameter.

N.B.: If the gate open limit switches are enabled ($\gamma 2 = 01$), the codes **ORO** and **COS2** flash.

N.B.: If the gate open limit switches are NOT enabled ($\gamma 2 = 00$), the codes **FCA1** and **FCA2** flash.

COMMAND STATUS:

The command status indicators on the display (segments **AP** = open, **PP** = step mode, **CH** = close, **PED** = partial opening) are normally off. They illuminate when a command is received (e.g.: when a step mode command is received, the segment **PP** illuminates).

SAFETY DEVICE STATUS:

The safety device status indicators on the display (segments **FT1/FT2**=photocells, **COS1**=sensing edges, **FCA1/FCA2**=gate open limit switches, if enabled, **STOP**) are

7.3 TEST mode

The TEST mode is used to test activation of the commands and safety devices with visual confirmation.

To activate the mode, press the TEST button with the automatic gate system at rest. If the gate is moving, pressing TEST stops the gate. Pressing the button again enables TEST mode.

If the flashing light and the gate open indicator lamp illuminate for one second each time a control is used or a safety device is activated.

The command signal status is shown on the left hand side of the display for 5 seconds, ONLY when the respective command signal is active (AP, CH, PP, PE, OR). For example, if the gate open command is activated, the letters AP appear on the display.

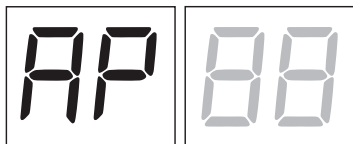

The status of the safety devices/inputs is shown on the right hand side of the display. The number of the terminal relative to the safety device in alarm state flashes.

Example: STOP contact in alarm state.

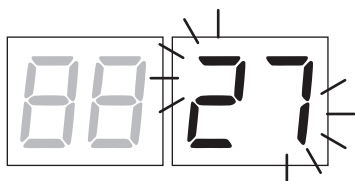

00	No safety device in alarm state, and no limit switch activated
27	STOP.
25	Sensing edge COS1.
24	Sensing edge COS2.
23	Photocell FT1.
22	Photocell FT2.
32	Gate open limit switch MOTOR 1 (BH23 Serie, if enabled - 72 0 I).
24	Gate open limit switch MOTOR 2 (BH23 Serie, if enabled - 72 0 I).

NOTA: If one or more contacts are open, the gate will not open or close. This does not apply for the limit switch signal state, however, which is shown on the display but does not prevent normal operation of the gate.

If more than one safety device is in alarm state, once the problem relative to the first device is resolved, the alarm for the next device is displayed. Any further alarm states are also displayed with the same logic.

Press the TEST button again to exit test mode.

After 10 seconds with no user input, the display returns to command and safety device state display mode.

7.4 Standby mode

This mode is activated after 30 minutes with no user input. The POWER LED flashes slowly.

Press UP ▲, DOWN ▼, +, - to reactivate the control unit.

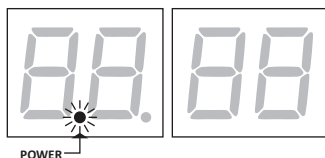

8 Travel acquisition

For the system to function correctly, the gate travel must be acquired by the control.

Before starting:

1. Select the automation system model installed with the parameter $R1$. The default setting for this parameter is motor type BR21.
2. Select the number of motors installed with the parameter 70 . This parameter is set for two motors by default.
3. Check that the operator present function is not enabled ($A7\ 00$).
4. Install mechanical stops in both the open and closed positions.
5. Move the gate into the closed position. The gate leaves must be against the mechanical stops.
6. Press **TEST** (see TEST mode in chapter 7) and check the command signal and safety device states. If any safety devices are not installed, jumper the relative contact or disable the device from the relative parameter (50 , 51 , 53 , 54 , 73 and 74).

ACQUISITION PROCEDURE:

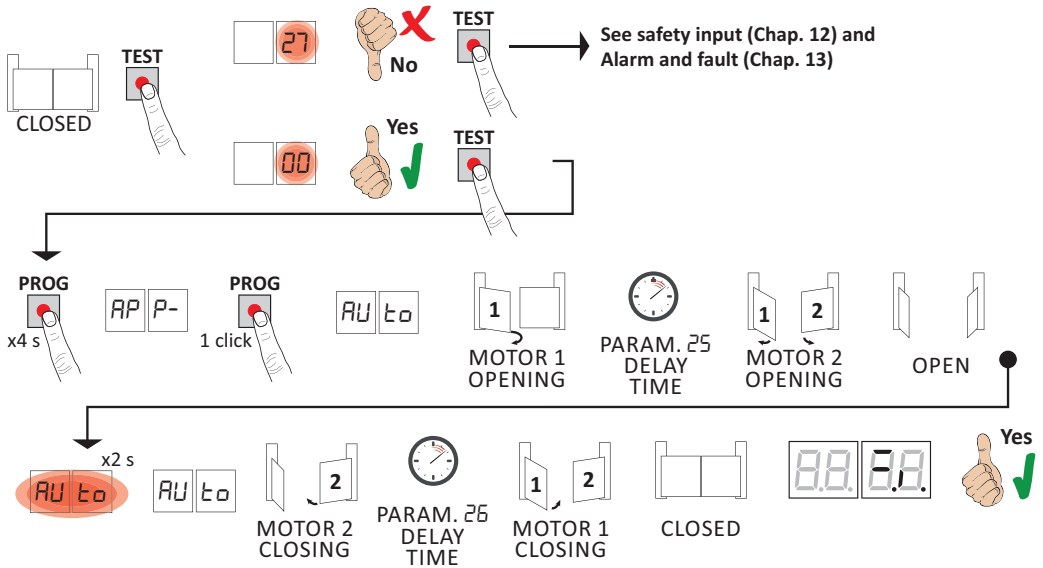

- Press and hold **PROG** for 4 seconds. $AP\ P-$ is shown on the display.
- Press **PROG** again. $AU\ t_0$ is shown on the display.
- **MOTOR 1** starts opening at low speed.
- After the delay time set with parameter 25 (with a default time setting of 3 s), **MOTOR 2** starts an opening manoeuvre.
- Once the gate open mechanical stop is reached, the gate stops briefly. The message $AU\ t_0$ flashes on the display for 2 s.
- When the message $AU\ t_0$ stops flashing and is steadily lit on the display, **MOTOR 2** closes first and then, after a delay set with parameter 25 (default setting 5 s), **MOTOR 1** closes until the gate closed mechanical stop is reached.

If the acquisition procedure is completed successfully, the display enters the command and safety device state display mode.

If the following error messages are shown on the display, repeat the acquisition procedure:

- $AP\ PE$: acquisition error. Press the **TEST** button to clear the error, and check the safety device in alarm state.
- $AP\ PL$: travel length error. Press the **TEST** button to clear the error, and check that both gate leaves are completely closed.

i For more information, see chapter 13 "Alarms and faults".

9 Index of parameters

PARAM.	FACTORY DEFAULT	DESCRIPTION	PAGE
R1	04	Selecting automation system model	46
R2	00	Automatic closure after pause time (from gate completely open)	46
R3	00	Automatic gate closing after mains power outage (black-out)	46
R4	00	Selecting step mode control function (PP)	46
R5	00	Pre-flashing	47
R6	00	Condominium function for partial open command (PED)	47
R7	00	Enabling operator present function.	47
R8	00	Gate open indicator / photocell test function and "battery saving"	47
11	04	MOTOR 1 Setting deceleration	47
12	04	MOTOR 2 Setting deceleration	47
13	10	Adjusting LEAF 1 position control	47
14	10	Adjusting LEAF 2 position control	47
15	99	Partial opening adjustment (%)	47
19	00	Adjusting MOTOR 1 stop advance on gate open stop	48
20	00	Adjusting MOTOR 2 stop advance on gate open stop	48
21	30	Setting automatic closing time	48
25	03	Adjusting opening delay of MOTOR 2	48
26	05	Adjusting closing delay of MOTOR 1	48
27	03	Setting reverse time after activation of sensing edge or obstacle detection (crush prevention).	48
28	00	Electric lock mode selection	48
29	00	Enable electric lock	48
30	07	Setting motor torque	48
31	15	Setting obstacle impact force sensitivity MOTOR 1	49
32	15	Setting obstacle impact force sensitivity MOTOR 2	49
33	10	Setting motor torque MOTOR 2	49
34	08	Setting start acceleration during opening and closing MOTOR 1	49
35	08	Setting start acceleration during opening and closing MOTOR 2	49
38	00	Enable lock release reverse impulse	49
40	04	Speed opening setting	49
41	04	Speed closing setting	49
49	01	Number of automatic closure attempts after activation of sensing edge or obstacle detection (crush protection)	49
50	00	Setting photocell mode during gate opening (FT1)	50
51	02	Setting photocell mode during gate closing (FT1)	50
52	01	Photocell (FT1) mode with gate closed	50
53	00	Setting photocell mode during gate opening (FT2)	50
54	00	Setting photocell mode during gate closing (FT2)	50
55	01	Photocell (FT2) mode with gate closed	50

PARAM.	FACTORY DEFAULT	DESCRIPTION	PAGE
56	00	Enable close command 6 s after activation of photocell (FT1-FT2)	51
65	05	Motor stop distance setting	51
70	02	Select number of motors installed	51
72	00	Enable limit switches	51
73	03	Configuring sensing edge COS1	51
74	00	Configuring sensing edge COS2	51
76	00	Configuring radio channel 1 (PR1)	52
77	01	Configuring radio channel 2 (PR2)	52
78	00	Configuring flashing light frequency	52
79	60	Selecting courtesy light mode	52
80	00	Clock contact configuration	52
81	00	Enable safeguarded gate closure/opening	53
82	03	Setting safeguarded closure/opening activation time	53
86	00	Enable maintenance alarm	53
87	00	Maintenance alarm hour counter setting	53
90	00	Restoring factory default values	54
n0	01	HW version	54
n1	23	Year of manufacture	54
n2	45	Week of manufacture	54
n3	67	Serial number	54
n4	89		54
n5	01		54
n6	23	FW version	54
o0	01	View manoeuvre counter	54
o1	23		54
h0	01	View manoeuvre hour counter	54
h1	23		54
d0	01	View control unit days on counter	55
d1	23		55
P1	00	Password	55
P2	00		55
P3	00		55
P4	00		55
CP	00	Password change protection	55

10 Parameters menu

PARAMETER	PARAMETER VALUE
A. 1.	04

A104	Selecting automation system model
	WARNING! If this parameter is not set correctly, the automation system may not function properly. N.B.: in the event of a reset to restore the default parameters, this parameter must be set again manually.
01	BM20 series - Irreversible piston for gate leaf lengths up to 3 m.
02	BR20 series - Irreversible piston for gate leaf lengths from 2,5 to 3,5 m.
03	BH23 series - Gear motor with irreversible articulated arm for gate leaf lengths up to 2,8 m.
04	BR21 series - In-ground irreversible gear motor for gate leaf lengths up to 3,5 m.
05	SMARTY series - Irreversible piston for gate leaf lengths from 5 to 7 m.

A200	Automatic closure after pause time (from gate completely open)
00	Disabled.
01-15	From 1 to 15 of gate closure attempts after photocell is triggered. Once the number of attempts set is reached, the gate remains open.
99	The gate tries to close indefinitely.

A300	Automatic gate closing after mains power outage
00	Disabled. The gate does not close automatically when mains power is restored.
01	Enabled. If the gate is NOT completely open, when mains power is restored, the gate closes after a 5 second warning signalled with the flashing light (independently of the value set with the parameter A5). The gate closes in "position recovery" mode (see chapter 16).

A400	Selecting step mode control function (PP)
00	Open-stop-close-stop-open-stop-close...
01	Condominium function: the gate opens and closes after the set automatic closing time. The automatic closing timer restarts if a new step mode command is received. Step mode commands are ignored while the gate is opening. This allows the gate to open completely and prevents the gate from closing when not required. If automatic closing is disabled (A2 00), the condominium function automatically attempts a closing manoeuvre A2 01.
02	Condominium function: the gate opens and closes after the set automatic closing time. The automatic closing timer does NOT restart if a new step mode command is received. Step mode commands are ignored while the gate is opening. This allows the gate to open completely and prevents the gate from closing when not required. If automatic closing is disabled (A2 00), the condominium function automatically attempts a closing manoeuvre A2 01.
03	Open-close-open-close.
04	Open-close-stop-open.

A5 00	Pre-flashing
00	Disabled. The flashing light is activated during opening and closing manoeuvres.
01-10	Flashing warning signal for 1 to 10 seconds prior to every manoeuvre.
99	5 second flashing warning signal prior to closing manoeuvre.
A6 00	Condominium function for partial open command (PED)
00	Disabled. The gate opens partially in step mode: open-stop-close-stop-open...
01	Enabled. Partial commands are ignored during gate opening.
A7 00	Enabling operator present function.
00	Disabled.
01	Enabled. The open (AP) or close (CH) button must be pressed continuously to operate the gate. The gate stops when the button is released.
A8 00	Gate open indicator / photocell test function and "battery saving"
00	The indicator is off when the gate is closed, and steadily lit during manoeuvres and when the gate is open.
01	The indicator flashes slowly during opening manoeuvres, and is lit steadily when the gate is completely open. It flashes quickly during closing manoeuvres. If the gate is stopped in an intermediate position, the lamp extinguishes twice every 15 seconds.
02	Set 02 if the output SC is used for the photocell test. See fig. 5.
03	Set to 03 if the output SC is used for the "battery saving" function. See fig. 6.
03	When the gate is completely open or closed, the control unit deactivates any accessories connected to terminal SC to reduce battery consumption.
04	Set to 04 if the output SC is used for the "battery saving" function and photocell test function. See fig. 6.
11 04	Setting deceleration MOTOR 1
12 04	Setting deceleration MOTOR 2
01-05	01= the gate decelerates near stops and the limit switch (if installed). ... 05= the gate decelerates long before stops and the limit switch (if installed).
13 10	Adjusting LEAF 1 position control when completely opens or closes The value selected must ensure that LEAF 1 is opened/closed correctly when it reaches the respective mechanical stop. Warning! Excessively low values cause the gate to reverse when it reaches the gate open stop. N.B.: with BR21 automation systems, with the gate leaf in the completely closed position, adjust the inner mechanical stop so that the lever of the gear motor can move by a few millimetres.
14 10	Adjusting LEAF 2 position control when completely opens or closes The value selected must ensure that LEAF 2 is opened/closed correctly when it reaches the respective mechanical stop. Warning! Excessively low values cause the gate to reverse when it reaches the gate closed stop. N.B.: with BR21 automation systems, with the gate leaf in the completely closed position, adjust the inner mechanical stop so that the lever of the gear motor can move by a few millimetres.
01-20	Motor revolutions.
15 99	Partial opening adjustment (%) N.B.: with double leaf swing gate installations, this parameter is set by default as the completely open position of LEAF 1. With single leaf swing gate installations, this parameter is set to 50% of total opening.
15-99	From 15% to 99% of total gate travel.

19 00	Adjusting stop advance of LEAF 1 when opening
20 00	Adjusting stop advance of LEAF 2 when opening
00	The leaf stops against the opening stop.
01-25	A leaf stop advance of 1 to 25 motor turns before the completely open position may be set.
21 30	Setting automatic closing time
	The timer starts from the gate open state and continues for the set time. Once the set time is reached, the gate closes automatically. The timer count restarts if a photocell is triggered.
00-90	Pause time settable from 00 to 90 s.
92-99	Pause time settable from 2 to 9 min.
25 03	Adjusting opening delay of MOTOR 2
	During opening, MOTOR 2 starts with an adjustable delay after MOTOR 1.
00-10	From 0 to 10 s.
26 05	Adjusting closing delay of MOTOR 1
	During closing, MOTOR 1 starts with an adjustable delay after MOTOR 2.
00-30	From 0 to 30 s.
27 03	Setting reverse time after activation of sensing edge or obstacle detection (crush prevention).
	This sets the reverse manoeuvre time after activation of the sensing edge or the obstacle detection system.
00-60	From 0 to 60 s.
28 00	Electric lock mode selection
00	Electric lock normally NOT powered. (powered only for 3 s when opening starts). N.B.: The electric lock is enabled by parameter 29.
01	"ventouse" type electric block (normally powered when the gate is completely closed).
02	"ventouse" type electric block (normally powered when the gate is completely opened or completely closed).
29 00	Enable electric lock
00	Disabled.
01	Enabled. When LEAF 1 approaches the gate closed stop, the controller delivers supplementary power to MOTOR 1 to latch the electric lock.
02	Enabled. When LEAF 1 approaches the gate closed stop, the controller delivers maximum power to MOTOR 1 to latch the electric lock. The obstacle detection system is disabled.
30 07	Setting motor torque
	Increasing or decreasing the value of the parameter increases or decreases motor torque and, as a result, adjusts obstacle detection sensitivity. Use values below 03 SOLO ONLY for particularly lightweight installations not exposed to severe weather conditions (strong winds or very cold temperatures). In installations with gate leaves of different lengths, they torque value may be set separately, setting a value for parameter 33 between 01 and 09.
01-09	01= -35%; 02= -25%; 03= -16%; 04= -8% (reduced motor torque = increased sensitivity). 05= 0%. 06= +8%; 07= +16%; 08= +25%; 09= +35% (increased motor torque = reduced sensitivity).

31 15	Setting obstacle impact force sensitivity MOTOR 1 If the reaction time to obstacle impact force is too long, reduce the value of the parameter. If the impact force exerted on obstacles is too high, reduce the value of parameter 30. N.B.: repeat the acquisition procedure after any change made to this parameter.
0 1- 10	Low motor torque: 01 = minimum obstacle impact force ... 10 = maximum obstacle impact force N.B.: only use these settings if the medium motor torque values are not suitable for the installation.
1 1- 19	Medium motor torque. Recommended setting for adjusting force settings correctly. 11 = minimum obstacle impact force ... 19 = maximum obstacle impact force.
20	Maximum motor torque. May only be used if the gate is equipped with a sensing edge.
32 15	Setting obstacle impact force sensitivity MOTOR 2 If the reaction time to obstacle impact force is too long, reduce the value of the parameter. If the impact force exerted on obstacles is too high, reduce the value of parameter 30 (or 33, if enabled: 33 different from 10). N.B.: repeat the acquisition procedure after any change made to this parameter.
0 1- 10	Low motor torque: 01 = minimum obstacle impact force ... 10 = maximum obstacle impact force N.B.: only use these settings if the medium motor torque values are not suitable for the installation.
1 1- 19	Medium motor torque. Recommended setting for adjusting force settings correctly. 11 = minimum obstacle impact force ... 19 = maximum obstacle impact force.
20	Maximum motor torque. May only be used if the gate is equipped with a sensing edge.
33 10	Setting motor torque MOTOR 2 Increasing or decreasing the value of the parameter increases or decreases motor torque and, as a result, adjusts obstacle detection sensitivity. Use values below 03 SOLO ONLY for particularly lightweight installations not exposed to severe weather conditions (strong winds or very cold temperatures).
0 1- 09	01= -35%; 02= -25%; 03= -16%; 04= -8% (reduced motor torque = increased sensitivity). 05= 0%. 06= +8%; 07= +16%; 08= +25%; 09= +35% (increased motor torque = reduced sensitivity).
10	The torque is set with parameter 30.
34 08	Setting start acceleration MOTOR 1
35 08	Setting start acceleration MOTOR 2
0 1- 10	01= the gate accelerates rapidly at start of manoeuvre. ... 10= the gate accelerates slowly and progressively at start of manoeuvre.
38 00	Enable electric lock release reverse impulse
00	Disabled.
0 1	Enabled. The controller applies a brief closing force (max. 4 s) to release the electric lock.
40 04	Setting opening speed (%)
41 04	Setting closing speed (%)
0 1- 05	01= 60% minimum speed ... 05= 100% maximum speed.
49 01	Setting number of automatic closure attempts after activation of sensing edge or obstacle detection (crush protection)
00	No automatic closure attempts.
0 1- 03	From 1 to 3 automatic closure attempts. We recommend setting a value equal to or lower than the value set for parameter #2. Automatic closure is only performed if the gate is completely open.

50 00	Setting photocell mode during gate opening (FT1)
00	DISABLED. Photocell is not active or not installed.
01	STOP. The gate stops and remains stationary until the next command is received.
02	IMMEDIATE REVERSE. The gate reverses immediately if the photocell is activated during gate opening.
03	TEMPORARY STOP. The gate stops as long as the photocell is obstructed. The gate resumed opening when the photocell is cleared.
04	DELAYED REVERSE. The gate stops if the photocell is obstructed. The gate closes when the photocell is cleared.

51 02	Setting photocell mode during gate closing (FT1)
00	DISABLED. Photocell is not active or not installed.
01	STOP. The gate stops and remains stationary until the next command is received.
02	IMMEDIATE REVERSE. The gate reverses immediately if the photocell is activated during gate closure.
03	TEMPORARY STOP. The gate stops as long as the photocell is obstructed. The gate resumed closing when the photocell is cleared.
04	DELAYED REVERSE. The gate stops if the photocell is obstructed. The gate opens when the photocell is cleared.

52 01	Photocell (FT1) mode with gate closed
00	If the photocell is obstructed, the gate cannot open.
01	The gate opens when an open command is received, even if the photocell is obstructed.
02	The photocell sends the gate open command when obstructed.

53 00	Setting photocell mode during gate opening (FT2)
00	DISABLED. Photocell is not active or not installed.
01	STOP. The gate stops and remains stationary until the next command is received.
02	IMMEDIATE REVERSE. The gate reverses immediately if the photocell is activated during gate opening.
03	TEMPORARY STOP. The gate stops as long as the photocell is obstructed. The gate resumed opening when the photocell is cleared.
04	DELAYED REVERSE. The gate stops if the photocell is obstructed. The gate closes when the photocell is cleared.

54 00	Setting photocell mode during gate closing (FT2)
00	DISABLED. Photocell is not active or not installed.
01	STOP. The gate stops and remains stationary until the next command is received.
02	IMMEDIATE REVERSE. The gate reverses immediately if the photocell is activated during gate closure.
03	TEMPORARY STOP. The gate stops as long as the photocell is obstructed. The gate resumed closing when the photocell is cleared.
04	DELAYED REVERSE. The gate stops if the photocell is obstructed. The gate opens when the photocell is cleared.

55 01	Photocell (FT2) mode with gate closed
00	If the photocell is obstructed, the gate cannot open.
01	The gate opens when an open command is received, even if the photocell is obstructed.
02	The photocell sends the gate open command when obstructed.

56 00	Enable close command 6 s after activation of photocell (FT1-FT2) N.B.: This parameter is not visible if <i>AB 03</i> or <i>AB 04</i> is set.
<i>00</i>	Disabled.
<i>01</i>	Enabled. When the photocell gate FT1 is crossed, a close command is sent 6 seconds later.
<i>02</i>	Enabled. When the photocell gate FT2 is crossed, a close command is sent 6 seconds later.

65 05	Setting motor stop distance
<i>01-05</i>	01= faster deceleration/shorter stop distance ... 05= slower deceleration/longer stop distance.

70 02	Select number of motors installed
<i>01</i>	1 motor.
<i>02</i>	2 motors. IMPORTANT: Use the same type of motor for both gate leaves.

72 00	Enable limit switches N.B.: This parameter is visible only if <i>A1 03</i> .
<i>00</i>	No limit switch installed.
<i>01</i>	Gate open limit switches installed.

73 03	Configuring sensing edge COS1
<i>00</i>	Sensing edge NOT INSTALLED.
<i>01</i>	NC contact (normally closed). The gate reverses only when opening.
<i>02</i>	Contact with 8k2 resistor. The gate reverses only when opening.
<i>03</i>	NC contact (normally closed). The gate always reverses.
<i>04</i>	Contact with 8k2 resistor. The gate always reverses.

74 00	Configuring sensing edge COS2 N.B.: This parameter is not visible if <i>A1 03</i> and <i>72 01</i> .
<i>00</i>	Sensing edge NOT INSTALLED.
<i>01</i>	NC contact (normally closed). The gate reverses only when closing.
<i>02</i>	Contact with 8k2 resistor. The gate reverses only when closing.
<i>03</i>	NC contact (normally closed). The gate always reverses.
<i>04</i>	Contact with 8k2 resistor. The gate always reverses.

76 00	Configuring radio channel 1 (PR1)
77 01	Configuring radio channel 2 (PR2)
00	STEP MODE.
01	PARTIAL OPENING
02	OPENING
03	CLOSING.
04	STOP.
05	Courtesy light. The output COR is managed from the remote control. The light remains lit as long as the remote control is active. The parameter 79 is ignored.
06	Courtesy light ON-OFF (PP). The output COR is managed from the remote control. The remote control turns the courtesy light on and off. The parameter 79 is ignored.
07	STEP MODE with confirmation for safety. ⁽¹⁾
08	PARTIAL OPENING with confirmation for safety. ⁽¹⁾
09	OPENING with confirmation for safety. ⁽¹⁾
10	CLOSURE with confirmation for safety. ⁽¹⁾

⁽¹⁾ To prevent gate manoeuvres caused by accidentally pressing a remote control button, confirmation is required to enable the command. Example: parameters 76 07 and 77 01 set:

- Pressing the CHA button on the remote control selects the step mode function, which must be confirmed within 2 seconds by pressing CHB on the remote control. Press CHB to activate partial opening.

78 00	Configuring flashing light frequency
00	The frequency is set electronically from the flashing light unit.
01	Slow flash.
02	Light flashes slowly when gate opens, rapidly when gate closes.

79 60	Selecting courtesy light mode
00	Disabled.
01	PULSE. The courtesy light illuminates briefly at the start of each manoeuvre.
02	ACTIVE. The light remains lit for the entire duration of the manoeuvre.
03-90	From 3 to 90 s. The light remains lit for the time period set after the manoeuvre is completed.
92-99	From 2 to 9 minutes. The light remains lit for the time period set after the manoeuvre is completed.

80 00	Clock contact configuration (INP1) When the clock function is active, the gate opens and remains open. At the end of the programmed time set with the external device (clock), the gate closes. N.B.: This parameter is not visible if A1 03 and 72 01.
00	When the clock function is active, the gate opens and remains open. Any command signal received is ignored.
01	When the clock function is active, the gate opens and remains open. Any command signal received is accepted. When the gate returns to the completely open position, the clock function is reactivated.

B100	<p>Enable safeguarded gate closure/opening</p> <p>Enabling this parameter ensures that the gate is not left open due to an incorrect and/or accidental command.</p> <p>This function is NOT enabled if:</p> <ul style="list-style-type: none"> • the gate receives a STOP command; • the sensing edge is activated; • the number of closure attempts set by parameter <i>B2</i> has been reached; • the acquired position is lost (perform position recovery, see chapter 16).
00	Disabled. The parameter <i>B2</i> is not displayed.
01	<p>Safeguarded closure enabled.</p> <p>After a period of time set with parameter <i>B2</i>, the control unit signals a 5 second warning with the flashing light, regardless of the parameter <i>B5</i>, and then closes the gate.</p>
02	<p>Safeguarded closure / opening enabled.</p> <p>If the gate is closed as a result of a step mode command, after a period of time set with parameter <i>B2</i>, the control unit signals a 5 second warning with the flashing light (regardless of the parameter <i>B5</i>), and then the gate closes.</p> <p>If the gate is stopped by the obstacle detection system during a closure manoeuvre, the gate closes after a period of time set with parameter <i>B2</i>.</p> <p>If the gate is stopped by the obstacle detection system during an opening manoeuvre, the gate closes after a period of time set with parameter <i>B2</i>.</p>
B203	<p>Setting safeguarded closure/opening activation time</p> <p>N.B.: this parameter is not visible if the value of parameter <i>B1</i> = 00.</p>
02-90	Wait time settable from 2 to 90 s.
92-99	Wait time settable from 2 to 9 min.
B600	<p>Enable maintenance alarm</p> <p>N.B.: Parameter visible if any password other than the default password is set (Parameter <i>P1</i>:P4).</p> <p>N.B.: in the event of a reset to restore the default parameters, this parameter must be set again manually.</p> <p>The maintenance alarm is activated when the value exceeds the hour limit set with parameters <i>B6</i> and <i>B7</i> (example: each 1500 manoeuvre hours).</p> <p>The message <i>ASSL</i> is shown on the display and the flashing light, with the motors stop, flashes with a regular duty cycle (1 s on / 4 s off) until system maintenance is performed and the alarm is reset.</p> <p>Press and hold TEST for 5 s to reset the alarm. The message <i>ASSL</i> is displayed, followed by the messages <i>UPdE</i> flashing for 4 seconds: to reset the alarm, hold down the TEST key until <i>donE</i> is displayed.</p> <p>If the TEST key is released, <i>AbtE</i> appears on the display and the alarm is not reset.</p> <p>The number of hours is saved by the control unit and the counter restarts.</p>
00	Disabled. When 9990 hours of operation are exceeded, the maintenance alarm is disabled entirely.
01	Maintenance enabled for a period = parameter value <i>B7</i> x10 hours.
02	Maintenance enabled for a period = parameter value <i>B7</i> x100 hours.
B700	<p>Maintenance alarm hour counter setting</p> <p>N.B.: Parameter visible with parameter <i>B6</i> 01 or <i>B6</i> 02.</p> <p>N.B.: in the event of a reset to restore the default parameters, this parameter must be set again manually.</p>
00	Disabled.
01-99	<p>from 10 to 990 hours with parameter <i>B6</i> 01 ...</p> <p>from 100 to 9900 hours with parameter <i>B6</i> 02.</p> <p>Maximum limit: 9990 hours (beyond this value the maintenance alarm is disabled entirely).</p>

90 00

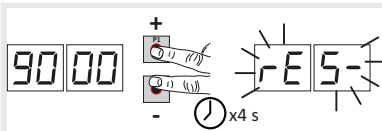
Restoring factory default values**NOTE** This procedure is only possible if NO data protection password is set.

Warning! Restoring default settings cancels all settings made previously except for parameter $R1$: after restore, check that all parameters are suitable for the installation.

The default factory settings may also be restored using the UP ▲ and/or DOWN ▼ buttons as follows:

- Turn off the power.
- Press and hold the UP ▲ and DOWN ▼ button until the unit switches on.
- The display flashes after 4 s rE5-.
- The default factory settings have now been restored.

Identification number

The identification number consists of the values of the parameters from $n0$ to $n6$.

N.B.: The values shown in the table are indicative only.

 $n001$ **HW version.** $n123$ **Year of manufacture.** $n245$ **Week of manufacture.** $n367$ $n489$ **Serial number.** $n501$ $n623$ **FW version.**

Example: 01 23 45 67 89 01 23

View manoeuvre counter

The number consists of the values of the parameters from $a0$ to $a1$ multiplied by 100.

N.B.: The values shown in the table are indicative only.

 $a001$ **Manoeuvres performed.** $a123$

Example: 01 23 x100 = 12.300 manoeuvres.

View manoeuvre hour counter

The number consists of the values of the parameters from $h0$ to $h1$.

N.B.: The values shown in the table are indicative only.

The maintenance alarm is activated when the value exceeds the hour limit set with parameters $B5$ and $B7$ (Example: each 1500 manoeuvre hours).

The message $R55E$ is shown on the display and the flashing light, with motors stop, flashes with a regular duty cycle (1 s on / 4 s off) until system maintenance is performed and the alarm is reset.

Press and hold TEST for 5 s to reset the alarm. The message $R55E$ is displayed, followed by the messages $UPdE$ flashing for 4 seconds: to reset the alarm, hold down the TEST key until $donE$ is displayed.

If the TEST key is released, $RbrE$ appears on the display and the alarm is not reset.

The number of hours is saved by the control unit and the counter restarts.

If the value $H0=99 H1=90$ is exceeded (9990 hours of operation) the maintenance alarm is no longer managed.

 $h001$ **Manoeuvre hours.** $h123$

Example: 01 23 = 123 hours.

View control unit days on counter

The number consists of the values of the parameters from $d0$ to $d1$.

N.B.: The values shown in the table are indicative only.

$d0$ 01

Days with unit switched on.

$d1$ 23

Example: $01\ 23 = 123$ days.

Password

Setting a password prevents unauthorised persons from accessing the settings.

With password protection active ($CP=01$), parameters may be viewed, but the values CANNOT be modified.

Only a single password is used to control access to the gate automation system.

WARNING: Contact the Technical Support Service if you lose your password.

$P1$ 00

$P2$ 00

$P3$ 00

$P4$ 00

Password activation procedure:

- Enter the desired values for parameters $P1$, $P2$, $P3$ and $P4$.
- Use the UP ▲ and/or DOWN ▼ buttons to view the parameter CP .
- Press and hold the + and - buttons for 4 seconds.
- The display flashes to confirm that the password has been saved.
- Switch the control unit off and on again. Check that password protection is activated ($CP=01$).

Temporary unlock procedure:

- Enter the password.
- Check that $CP=00$.

Password cancellation procedure:

- Enter the password ($CP=00$).
- Save the values $P1$, $P2$, $P3$, $P4 = 00$
- Use the UP ▲ and/or DOWN ▼ buttons to view the parameter CP .
- Press and hold the + and - buttons for 4 seconds.
- The display flashes to confirm that the password has been cancelled (the values $P1\ 00$, $P2\ 00$, $P3\ 00$ and $P4\ 00$ indicate that no password is set).
- Switch the control unit off and on again ($CP=00$).

CP 00

Changing password

00

Protection deactivated.





01





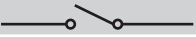

Protection activated.

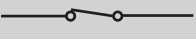
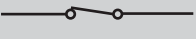
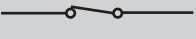
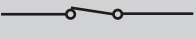
11 Commands and Accessories

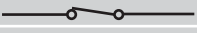
 If not installed, safety devices with NC contacts must be jumpered at the COM terminals, or disabled by modifying the parameters *50*, *51*, *53*, *54*, *73* and *74*.

KEY: N.A. (Normally Open) .
N.C. (Normally Closed).

CONTACT	DESCRIPTION
13 (COR) 14 	Output (potential free contact) for connecting courtesy light. 230 Vac 100 W - 24 Vac/dc 40 W (fig. 2).
16(+LAM) 15 (COM) 	Connection for flashing light (24 Vdc - duty cycle 50%). The settings for the pre-manoeuve flashing warning signal may be selected with parameter <i>R5</i> , while the flashing mode is set with parameter <i>7B</i> .
17(+ES) 15 (COM) 	Input for connecting electric lock, 12 Vdc max. 15 W. The function of the electric lock is determined by parameter <i>29</i> .
18(+24V) 15 (COM)	Power feed for external devices. See technical characteristics.
20(SC) 19 (COM) 	Connection for gate open indicator lamp. 24 Vdc 3 W (fig 2). The function of the indicator lamp is determined by parameter <i>AB</i> .
20(SC) 19 (COM) 	Photocell test connection and/or battery saving (fig. 5 and 6). The power feed for the photocell transmitters (TX) may be connected to this. Set the parameter <i>AB 02</i> to enable the test function. Each time a command is received, the control unit switches the photocells off and on to check that the contact changes state correctly. Power feeds for all external devices may be connected to reduce battery consumption (if batteries are used). Set <i>AB 03</i> or <i>AB 04</i> . WARNING! If contact 20 (SC) is used for the photocell test function or battery saving function, a gate open indicator lamp cannot be connected.
22(FT2) 21 (COM) 	Input (NC) for connecting photocells FT2 (fig. 4-5-6). The photocells FT2 are configured by default with the following settings: <ul style="list-style-type: none"> - <i>53 00</i> . Photocell FT2 disabled when gate is opening. - <i>54 00</i> . Photocell FT2 disabled when gate is closing. - <i>55 01</i> . The gate opens when an open command is received if photocell FT2 is obstructed. If the photocells are not installed, jumper the terminals 21 (COM) - 22 (FT2) or set the parameters <i>53 00</i> and <i>54 00</i> . WARNING! Use R90/F4ES , G90/F4ES or T90/F4S series photocells.
23(FT1) 21 (COM) 	Input (NC) for connecting photocells FT1 (fig. 4-5-6). The photocells FT1 are configured by default with the following settings: <ul style="list-style-type: none"> - <i>50 00</i> . Photocell triggers only during gate closure. Photocell is ignored during gate opening. - <i>51 02</i> . Movement is reversed if the photocell is triggered during gate closure. - <i>52 01</i> . The gate opens when an open command is received if photocell FT1 is obstructed. If the photocells are not installed, jumper the terminals 23 (FT1) - 21 (COM) or set the parameters <i>50 00</i> and <i>51 00</i> . WARNING! Use R90/F4ES , G90/F4ES or T90/F4S series photocells.
24(INP2) 26 (COM) 	Auxiliary input for connecting either a sensing edge or a gate open limit switch on LEAF 2 (fig. 2). <ol style="list-style-type: none"> 1. A sensing edge COS2 in addition to COS1. The sensing edge is configured by default with the following settings: <ul style="list-style-type: none"> - <i>74 00</i>. The sensing edge COS2 (NC contact) is disabled. 2. If the sensing edge is not installed, jumper the terminals 24 (INP2) - 26 (COM) or set the parameter <i>74 00</i>. BH23 series swing gate automation systems with articulated arm (<i>R1 03</i>), gate open limit switch on LEAF 2. The gate open limit switch for LEAF 2 is disabled by default <i>72 00</i>.

CONTACT	DESCRIPTION
25(COS1) 26(COM) 	Input (NC or 8 kOhm) for connecting sensing edge COS1 (fig. 2). The sensing edge is configured by default with the following settings: – 73 03. If the sensing edge COS1 (NC contact) is enabled, the gate always reverses. If the sensing edge is not installed, jumper the terminals 25(COS1) - 26(COM) or set the parameter 73 00.
27(ST) 26(COM) 	STOP command input (NC). The current manoeuvre is arrested if the safety contact opens. N.B.: jumper the contact if it is not used.
29 (ANT) 30 	Antenna connector for slot-in radio receiver board. Use RG58 if an external antenna is used; maximum recommended length: 10 m. N.B.: do not make joints in cable.
32(INP1) 31(COM) 	Auxiliary input for connecting either a timer clock contact or a gate open limit switch on LEAF 1 (fig. 2). 1. Clock timer contact input (N.O.). When the clock function is active, the gate opens and remains open. At the end of the programmed time set with the external device (clock) the gate closes. 2. BH23 series swing gate automation systems with articulated arm (R1 03), gate open limit switch on LEAF 1. The gate open limit switch for LEAF 1 is disabled by default 72 00.
33(AP) 37(COM) 	Open control signal input (N.O.).
34(CH) 37(COM) 	Close command input (N.O.).
35(PP) 37(COM) 	Step by step mode command input (N.O.). The function of the control is determined by parameter R4.
36(PED) 37(COM) 	Partial open control signal input (N.O.). On double leaf gate automation systems, by default, the partial opening command opens LEAF 1 completely. With single leaf swing gate installations, by default, partial opening is 50% of total opening.
RECEIVER CARD	Connector for plug-in radio receiver board. The control unit has two radio remote control functions by default: – PR1 - step mode command (modifiable with parameter 75). – PR2 - partial opening command (modifiable with parameter 77).
BATTERY CHARGER B71/BCHP	In the event of a mains power loss, the control unit is powered by the batteries. When battery power is used, <i>bAtE</i> is shown on the display and the flashing light flashes briefly at intervals until mains power is restored or until the battery voltage drops below the minimum permissible limit. In this case, <i>bELl</i> (Battery Low) is shown on the display and the control unit accepts no commands. If mains power is lost while the gate is moving, the gate stops and then automatically resumes the interrupted manoeuvre after 2 seconds. N.B.: in battery power mode, a fixed delay time of 1.5 s is applied even if delay times are disabled with parameters 25 and 25.
BATTERY KIT 2x12 Vdc 4,5 Ah (B71/BCHP/EXT)	To reduce battery consumption, the positive power feed wire of the photocell transmitters and receiver may be connected to terminal SC (see fig. 5-6). Set <i>AB 03</i> or <i>AB 04</i> . In this configuration, the control unit disconnects power from the accessory devices when the gate is completely open or completely closed.
Only AGM type	WARNING! the batteries must always be connected to the electronic control unit in order to charge. Periodically (at least every 6 months), check that the batteries are in good working order. For more information, refer to the installation manual for the B71/BCHP battery charger.

12 Safety input and command status (TEST mode)

With no currently active commands, press the TEST button and check the following:

DISPLAY	POSSIBLE CAUSE	ACTION BY SOFTWARE	PHYSICAL CORRECTIVE ACTION
88 27	The safety STOP contact is open.	-	Install a STOP button (NC) or jumper the ST contact with the COM contact.
88 25	Sensing edge COS1 not connected or incorrectly connected.	Set the parameter 73 00 if not used or to disable.	Jumper contact COS1 with contact COM, if not used or to disable
88 24	Sensing edge COS2 not connected or incorrectly connected (BM20, BR20, BR21, SMARTY or BH23 series, if parameter is set to 72 00)	Set the parameter 74 00 if not used or to disable.	Jumper contact INP2 with contact COM, if not used or to disable.
88 23	Photocell FT1 not connected or incorrectly connected.	Set the parameter 50 00 e 51 00 if not used or to disable.	Jumper contact FT1 with contact COM, if not used or to disable. Check connection referring to relative connection diagram (figure 4).
88 22	Photocell FT2 not connected or incorrectly connected.	Set the parameter 53 00 e 54 00 if not used or to disable.	Jumper contact FT2 with contact COM, if not used or to disable. Check connection referring to relative connection diagram (figure 4).
88 32	LEAF1 open limit switch not connected, or LEAF1 completely open (for BH23 series only if parameter is set to 72 0 I).		Check connection of limit switches.
88 24	LEAF2 open limit switch not connected, or LEAF2 completely open (for BH23 series only if parameter is set to 72 0 I).		Check connection of limit switches.
PP 00	If occurs with no voluntary command, the contact (N.O.) may be faulty or one of the buttons may be incorrectly connected.	-	Check PP - COM contacts and connections to buttons.
CH 00		-	Check CH - COM contacts and connections to buttons.
AP 00		-	Check AP - COM contacts and connections to buttons.
PE 00		-	Check PED - COM contacts and connections to buttons.
0-00	If occurs with no command, the contact (N.O.) may be faulty or the timer may be incorrectly connected.	-	Check INP1 - COM contacts. Contact must not be jumpered if not used.

N.B: press TEST to exit TEST mode.

We recommend troubleshooting safety device and input status errors with “corrective action by software” only.

13 Alarms and faults

PROBLEM	ALARM	POSSIBLE CAUSE	ACTION
The gate does not open or close.	POWER LED off	No power.	Check power cable.
	POWER LED off	Fuses blown.	Replace fuse. Always disconnect from mains power before removing fuses.
	<i>DF St</i>	Input mains power voltage fault. Control initialisation failed.	Disconnect from mains power, wait 10 seconds then reconnect to the mains and switch on. We recommend replacing the control unit if the problem persists.
	<i>Pr Ot</i>	Overcurrent detected in inverter.	Press the TEST button twice or perform 3 command requests in succession.
	<i>SECO</i>	Incorrect connection between SEC1 and SEC2 of the transformer.	Swap the connection between SEC1 and SEC2.
	<i>dRtA</i>	Incorrect travel length values.	Press the TEST button and check the safety device/s in alarm state and the connections of the safety devices. Repeat acquisition procedure.
	<i>Not 1</i>	Motor 1 not connected.	Check the motor cable.
	<i>Not 2</i>	Motor 2 not connected.	Check the motor cable.
	<i>FUSE</i>	Fuse F1 blown or damaged. This message is not visible if controller is in battery power mode.	Replace fuse. Always disconnect from mains power before removing and refitting fuses.
	Example: <i>15 EE</i> <i>21 EE</i>	Configuration parameter error.	Set configuration value correctly and save.
	<i>b t L O (btLO)</i>	Flat batteries.	Wait for mains power to be restored.
Acquisition procedure does not complete correctly.	<i>RP P.E</i>	TEST button pressed accidentally. Safety devices in alarm state.	Repeat acquisition procedure. Press the TEST button and check the safety device/s in alarm state and the connections of the safety devices.
		Excessive voltage drop.	Repeat acquisition procedure. Check mains voltage.
	<i>RP PL</i>	Travel length error.	Move gate into completely closed position and repeat the procedure. Check cable of limit switches (if installed). Replace the cable if the problem persists. Reset default control unit parameters and repeat the procedure.
Remote control has limited range and does not work while automated gate is moving.	-	The radio transmission is impeded by metal structures and reinforced concrete walls.	Install the antenna outside.
	-	Flat batteries.	Replace the transmitter batteries.
The flashing light is not working.	-	Bulb / LED blown or flashing light wires disconnected.	Check LED circuit and/or connector wires.
With gate stops, the flashing light flashes with a regular duty cycle (1 s on / 4 s off).	<i>RSS t (ASSt)</i>	Maintenance alarm.	Perform a maintenance program. Press and hold TEST for 5 s to reset the alarm. The message <i>RSS t</i> is displayed, followed by the messages <i>UP dt</i> flashing for 4 seconds: to reset the alarm, hold down the TEST key until <i>don E</i> is displayed. If the TEST key is released, <i>Pr br t</i> appears on the display and the alarm is not reset. The manoeuvre counter resets.
Gate open indicator lamp does not work.	-	Bulb blown or wires disconnected.	Check the bulb and/or wires.
Gate does not perform desired manoeuvre.	-	Motor leads crossed.	Swap two wires on terminal X-Y-Z or Z-Y-X.

N.B.: Press the TEST button to temporarily cancel the alarm.

The next time a command is received, the alarm reappears on the display if the problem has not been resolved.

14 Procedural verifications - INFO Mode

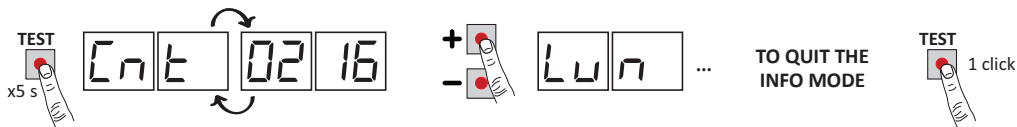

INFO mode may be used to view certain parameters measured by the **B70/2DCHP** controller. Press and hold the TEST button for 5 seconds from the “View command signals and safety devices” mode with the motor stationary. The control unit displays the following parameters and the corresponding measured values in sequence:

Parameter	Function
r2.00	View for 3 s the firmware version of the control unit.
Cnt 1 / Cnt 2	Displays the position of MOTOR 1 / MOTOR 2, expressed in revolutions and relative to total length, at the time of the test.
Lun 1 / Lun 2	View total length of MOTOR 1/ MOTOR 2 programmed travel , in motor revolutions.
rPn 1 / rPn 2	View MOTOR 1/MOTOR 2 speed, in revolutions per minute (RPM).
ANP 1 / ANP 2	View current absorption of MOTOR 1/MOTOR 2, in Amperes (e.g.: 001.1 = 1,1 A 016.5 = 16,5 A). If the MOTOR 1 / MOTOR 2 is stationary, the current absorption value is 0. Activate a command function to test current absorption.
bUS	System OK indicator. To check for overloading (e.g.: too many utilities connected to 24 V output) or if the mains voltage is too low, compare the parameters read with values indicated as follows with the motor stationary: mains voltage= 230 Vac (nominal), bUS= 37.6 mains voltage= 207 Vac (-10%), bUS= 33.6 mains voltage= 253 Vac (+10%), bUS= 41.6
CNP 1 / CNP 2	Display current, expressed in Amperes, used to compensate for strain detected by MOTOR 1 / MOTOR 2 due, for example, to low external temperatures (e.g.: 0 = 0 A ... 4 = +3 A). At the beginning of a manoeuvre from the completely open or completely closed position, if the control unit detects a strain higher than the value stored in its memory during the travel acquisition cycle, the controller automatically increases the current delivered to MOTOR 1 / MOTOR 2.
ASC 1 / ASC 2	Display current threshold, expressed in Amperes, at which the obstacle detection function (crush prevention) of MOTOR 1 / MOTOR 2 is triggered. This value is calculated automatically by the controller in relation to the settings of parameters 30, 31 and 32. For the motor to function correctly, ANP must always be lower than the value ASC.
Et n 1 / Et n 2	Indicates time taken by motor to detect an obstacle, as set with parameter 31/32, in seconds. E.g. 1.000 = 1 s / 0.120 = 0.12 s (120 ms). Ensure that the manoeuvre time is more than 0.3 s.
AbS 1 / AbS 2	MOTOR 1 / MOTOR 2 status OK indicator. In normal conditions, this value is less than 500. If the value exceeds 2000, the controller disables the motor. A value exceeding 500 indicates that the characteristics of the connection cable are inadequate for the installation or that the connection cable is too long or of inadequate cross section, or may indicate an electrical fault of the brushless motor.
UP	If the control unit is capable of identifying the position of the gate leaf when the test is conducted, the following is shown on the display: UP__ position known, normal operation. UP L_ LEAF 1 position unknown, position recovery in progress. UP L_ LEAF 2 position unknown, position recovery in progress. UP l2 positions of both leaves unknown, position recovery in progress.
OC	Indicates the state of the automation system (open/closed). OC OP automation system opening (motor active). OC CL automation system closing (motor active). OP - O automation system completely open (motor not actives). OP - C automation system completely closed (motor not actives).
UF	UF U mains voltage too low or overload. UF H motors overcurrent.
Hour	Displays the number of hours remaining before the maintenance alarm is activated. The number is preceded by a – (minus) symbol. If the number of remaining hours is a four figure value, the minus symbol (–) is replaced by a point. Example: -1234 hours remaining until maintenance alarm = .1234 • Pressing ↓ (DOWN arrow): view number of hours of last maintenance service. The first service is indicated as 0.0.0.0. • Pressing ↑ (UP arrow): return to remaining hours display.

- If only one motor is connected to the control unit, the parameters relative to “MOTOR 1” only are displayed.
- Use the + / - buttons to scroll through the parameters. When the last parameter in the sequence is reached, press the - button to return through the previous parameters.
- In INFO mode, the automation system may be activated to test operation in real time.
- Press and hold the TEST button for a few seconds to exit INFO mode

15 Mechanical release

In the event of power failure, the gate may be unlocked by following the instructions given in the use and maintenance manual of the automation system. On receiving the first command signal after mains power is restored, the control unit starts an opening manoeuvre in position recovery mode (see chapter 16).

16 Position recovery mode

On receiving the first command signal after a power failure or after detecting an obstacle in the same position three consecutive times, the control unit starts a manoeuvre in position recovery mode.

On receiving a command signal, the gate starts a manoeuvre at low speed. The flashing light flashes with a different duty cycle than normal (3 s on, 1.5 s off).

The control unit recovers the installation data during this procedure. **Warning:** Do not use any controls until the gate has performed a complete manoeuvre for both leaves.

In the case of **BH23** automation systems, position recovery is performed immediately when the limit switches (if installed) are activated.

If the gate is released in the completely open or completely closed position with the control unit powered, always return the gate leaves into their original positions before locking the gate release again. The gate will resume normal operation on receipt of the first control command.

WARNING: Releasing the gate in an intermediate position is not recommended, as it may cause the leaf position parameters to be lost (see parameters C_{n1} / C_{n2} in INFO mode). In this case, the control unit does not enable position recovery.

17 Initial testing

- Turn on the power supply.
- Check that the automation system motors rotate in the correct direction. If the leaves do not move correctly, swap any two of the wires on the X-Y-Z terminal. On **BH23** series automation systems with articulated arm, if the **MOT1** and **MOT2** connections are swapped, also swap the limit switch connections **INP1** and **INP2** (if installed).
- Check that all connected controls are working correctly.
- Check travel and deceleration.
- Check that the impact force is correct, in compliance with EN 12453 and EN12445.
- Check that the safety devices are activated correctly.
- If the battery kit is installed, disconnect from mains and check that the batteries are working.
- Disconnect from mains power and disconnect the batteries (if used), then reconnect. Check the correct completion of the position recovery phase when opening and when closing.
- Check the limit switch settings (if installed).

18 Maintenance

Perform scheduled maintenance every 6 months.

Check cleanliness and function.

If the unit contains dirt, moisture, insects or other foreign matter, disconnect from mains power and clean the board and the housing.

Repeat the initial installation test procedure after cleaning.

If any corrosion is found on the printed circuit board, evaluate if it is necessary to replace the board itself.

Check that the battery is in good working order.

19 Disposal



The product may only be uninstalled by qualified technical personnel, following suitable procedures for removing the product correctly and safely. This product consists of numerous different materials. Some of these materials may be recycled, while others must be disposed of correctly at the specific recycling or waste management facilities indicated by local legislation applicable for this category of product.

Do not dispose of this product as domestic refuse. Observe local legislation for differentiated refuse collection, or hand the product over to the vendor when purchasing an equivalent new product.

Local legislation may envisage severe fines for the incorrect disposal of this product.

Warning! Some parts of this product may contain substances that are harmful to the environment or dangerous and which may cause damage to the environment or health risks if disposed of incorrectly.

20 Additional information and contact details

ROGER TECHNOLOGY is the exclusive proprietor holder of all rights regarding this publication. ROGER TECHNOLOGY reserves the right to implement any modifications without prior notification. Copying, scanning or any alterations to this document are prohibited without express prior authorised from by ROGER TECHNOLOGY.

This instruction manual and the warnings for the installer are given in printed form and included in the box containing the product.

The digital version of this documentation (in PDF format) and all future revisions are available from the reserved area of our website www.rogertechnology.com/B2B, in the section 'Self Service'.

ROGER TECHNOLOGY CUSTOMER SERVICE:

business hours: Monday to Friday
08:00 to 12:00 - 13:30 to 17:30
Telephone no: +39 041 5937023
E-mail: service@rogertechnology.it
Skype: service_rogertechnology

To request support for any problems or for any other queries regarding the automation system, please compile the online form "REPAIRS" in the 'Self Service' area of our website www.rogertechnology.com/B2B.

21 Declaration of Conformity

I the undersigned, as acting legal representative of the manufacturer
Roger Technology - Via Botticelli 8, 31021 Bonisiolo di Mogliano V.to (TV)
hereby DECLARE that the appliance described below:

Description: Controller unit for automatic gates

Model: **B70/2DCHP**

Is conformant with the legal requisites of the following directives:

- 2006/42/EC
- 2004/108 /EU
- 2011/65/EC

and that all the standards and/or technical requirements indicated as follows have been applied:

- EN 61000-6-3
- EN 61000-6-2

Last two figures of year in which marking was applied **CE 14**.

Place: Mogliano V.to

Date: 25-05-2014

Signature

