

RAYNOR®

SAFETY SIGNAL™

GARAGE DOOR OPENER

Model 3800RGD

Raynor Garage Doors
1101 E. River Rd.
Dixon, Illinois 61021
www.raynor.com



*For Residential and Light Duty Commercial Use
Install On Sectional Doors With
Torsion Assemblies Only*

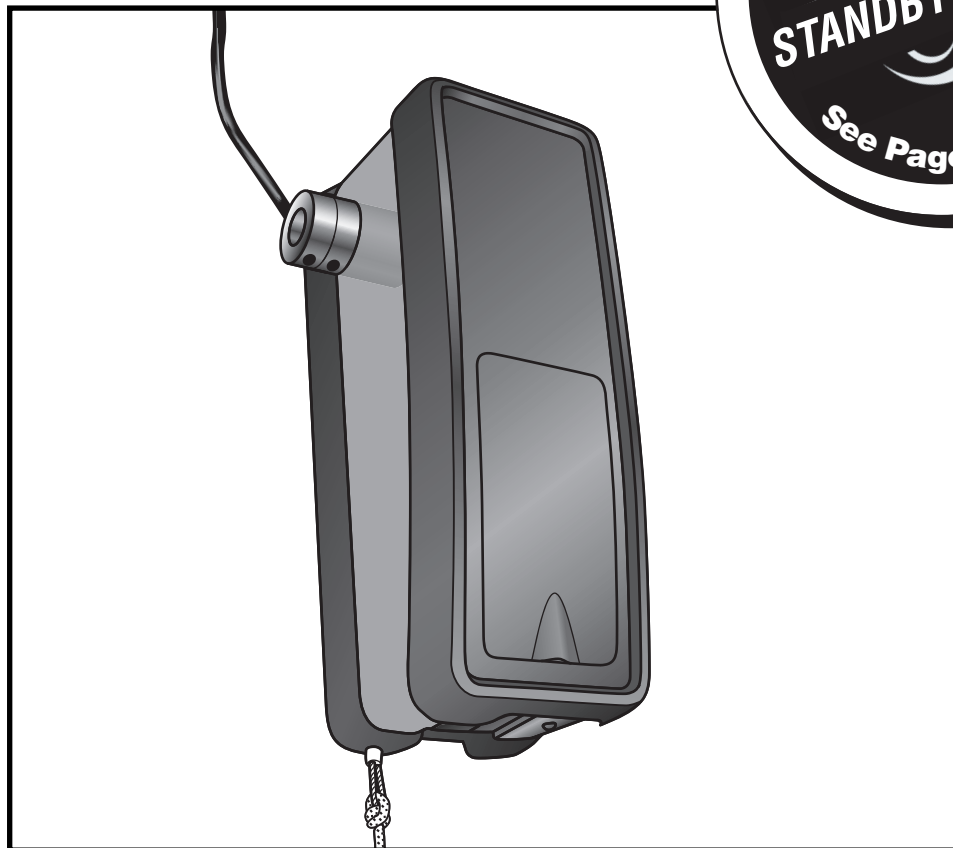

Owner's Manual

- Please read this manual and the enclosed safety materials carefully!
- Fasten the manual near the garage door after installation.
- The door WILL NOT CLOSE unless The Protector System® and cable tension monitor are connected and properly aligned.
- Periodic checks of the opener are required to ensure safe operation.
- The model number label is located behind the hinged door of your opener.
- Do NOT exceed 10 complete cycles of door operation per hour.

TABLE OF CONTENTS

Introduction	2-5	Operation	21-27
Safety symbol review and signal word review	.2	Operation safety instructions	.21
Planning	.3	Using your garage door opener	.21
Preparing your garage door	.4	Using the wall-mounted door control	.22
Tools	.4	Using the remote control	.23
Specifications	.4	Troubleshooting	.23
Carton inventory	.5	The remote control battery	.23
Hardware inventory	.5	Care of your opener	.24
Assembly	6	Having a problem? (Troubleshooting)	.24-25
Attach the collar to the motor unit	.6	Smart Control Panel™ messages	.26
Attach mounting bracket to the motor unit	.6	Diagnostic Chart	.27
Installation	7-16	Programming	28-30
Installation safety instructions	.7	To add or reprogram a hand-held remote control	.28
Position the opener	.7	To erase all codes from motor unit memory	.28
Attach the emergency release rope and handle	.8	3-Button remote	.28
Install the power door lock	.8	To add, reprogram or change	
Attach the cable tension monitor (Required)	.9	a keyless entry PIN	.29
Install the door control	.10	Programming work light or additional work light	.30
Install remote light	.11	Repair Parts	31-32
Electrical requirements	.12	Installation parts	.31
Mount the Standby Power Unit (SPU) (not provided)	.13	Motor unit assembly parts	.32
Install The Protector System®	.14-16	Accessories	33
Adjustment	17-20	Operator Notes	34-35
Program the travel limits	.17	Repair Parts and Service	36
Setting the force	.18	Warranty	36
Test the safety reversal system	.19		
Test The Protector System®	.19		
Test cable tension monitor	.20		
Test power door lock	.20		
To open door manually	.20		

INTRODUCTION

Safety Symbol Review and Signal Word Review

This garage door opener has been designed and tested to offer safe service provided it is installed, operated, maintained and tested in strict accordance with the instructions and warnings contained in this manual.

 **WARNING**

Mechanical

 **WARNING**

Electrical

CAUTION

When you see these Safety Symbols and Signal Words on the following pages, they will alert you to the possibility of **serious injury or death** if you do not comply with the warnings that accompany them. The hazard may come from something mechanical or from electric shock. Read the warnings carefully.

When you see this Signal Word on the following pages, it will alert you to the possibility of damage to your garage door and/or the garage door opener if you do not comply with the cautionary statements that accompany it. Read them carefully.

Planning

Survey your garage area to see if any of the conditions below apply to your installation. Additional materials may be required. You may find it helpful to refer back to this page as you proceed with the installation of your opener.

Depending on your requirements, there are several installation steps which may call for materials or hardware not included in the carton.

This opener is compatible with:

- Doors that use a torsion bar, springs and a door no more than 14' (4.2 m) high.
- 4"-6" (10 cm - 15 cm) drums, not to be used on tapered drums over 6" (15 cm).
- High lift and standard lift sectional doors up to 14' (4.2 m) high.
- Doors up to 18' (5.4 m) wide.
- Doors up to 180 sq. ft. (16.7 sq. m).
- 1" (2.5 cm) torsion bar only.
- Review or inspect proposed installation area. Opener can be installed on left or right side of door. Select the side that meets the requirements listed below.
 - Must have minimum of 2-1/2" (6.4 cm) between the garage wall and the center of the torsion bar.
 - Must have minimum of 3" (7.6 cm) between the ceiling and the center of torsion bar.
 - Must have minimum of 8" (20.3 cm) between the side garage wall (or obstruction) and the end of torsion bar.

- The torsion bar must extend at least 1" to 5" (2.5 cm to 12 cm) past the bearing plate.
- An electric outlet is required within 6' (1.8 m) of the installation area. If outlet does not exist, contact a qualified electrician.
- Depending upon garage construction, extension brackets or wood blocks may be needed to install safety reversing sensors.
- Alternate floor mounting of the safety reversing sensors will require hardware not provided.
- A model 475RGD EverCharge™ Standby Power Unit is strongly recommended if there is no access door to the garage, as this opener cannot be used in conjunction with an external emergency release mechanism.
- Any gap between the floor and the bottom of the door must not exceed 1/4" (6 mm). Otherwise the safety reversal system may not work properly.

NOTE: Inspect the torsion bar while the door is raised and lowered. It is important that there is no noticeable movement up and down or left and right. If this type of movement is not corrected, life of this opener will be greatly reduced.

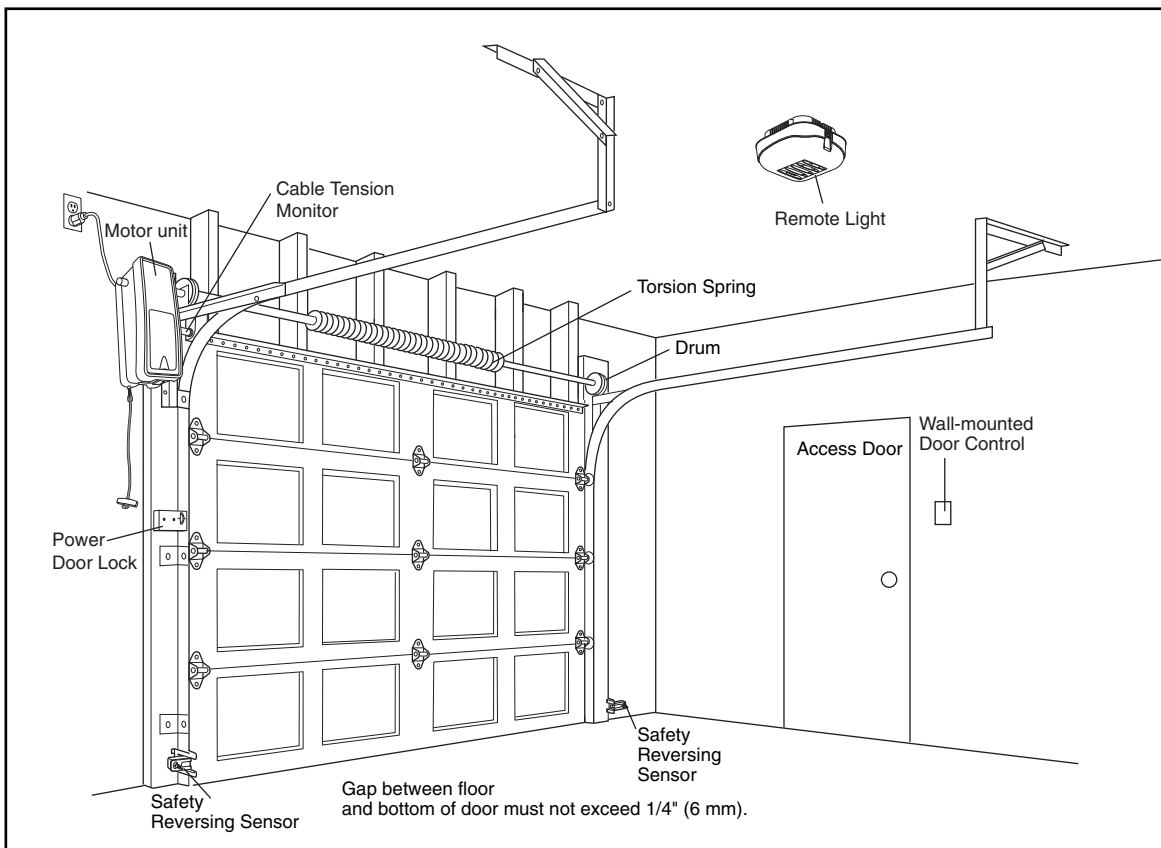

Preparing your Garage Door

Before you begin:

- Disable locks.
- Remove any ropes connected to garage door.
- **Complete the following test** to make sure your garage door is balanced and is not sticking or binding:

1. Lift the door about halfway as shown. Release the door. If balanced, it should stay in place, supported entirely by its springs.
2. Raise and lower the door to see if there is any binding or sticking.

If your door binds, sticks or is out of balance, call a trained door systems technician.

3. Verify equal cable tension on each side of door. Cable tension should remain equal during the entire travel of the door.

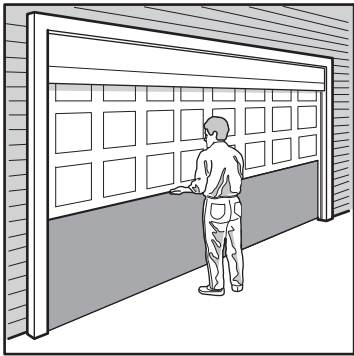

Sectional Door

Tools needed

During assembly, installation and adjustment of the opener, instructions will call for hand tools as illustrated below.

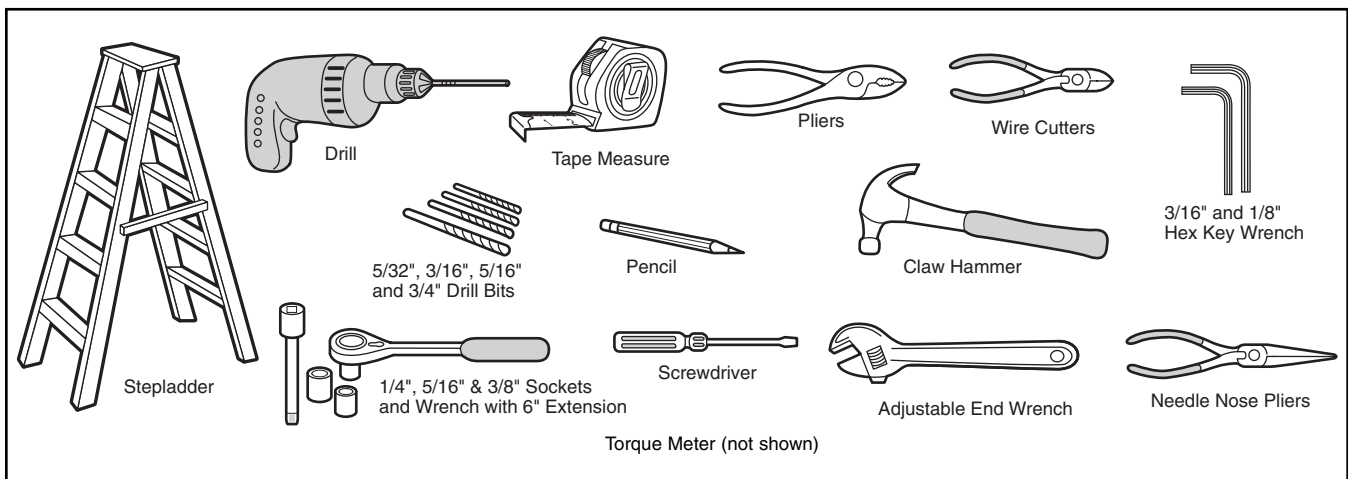

WARNING

To prevent possible **SERIOUS INJURY** or **DEATH**:

- **ALWAYS** call a trained door systems technician if garage door binds, sticks or is out of balance. An unbalanced garage door may not reverse when required.
- **NEVER** try to loosen, move or adjust garage door, door springs, cables, pulleys, brackets or their hardware, **ALL** of which are under **EXTREME** tension.
- Disable **ALL** locks and remove **ALL** ropes connected to garage door **BEFORE** installing and operating garage door opener to avoid entanglement.

CAUTION

To prevent damage to garage door and opener:

- **ALWAYS** disable locks **BEFORE** installing and operating the opener.
- **ONLY** operate garage door opener at 120V, 60 Hz to avoid malfunction and damage.
- Do **NOT** exceed 10 complete cycles of door operation per hour.

Specifications

Volts120 Vac - 60 Hz, **ONLY**
 Current1.0 AMP
 Rated Load325 in.lb/sec
 10 Cycles per Hour

Carton Inventory

Your garage door opener is packaged in one carton which contains the motor unit and the parts illustrated below. Note that accessories will depend on the model

purchased. If anything is missing, carefully check the packing material.

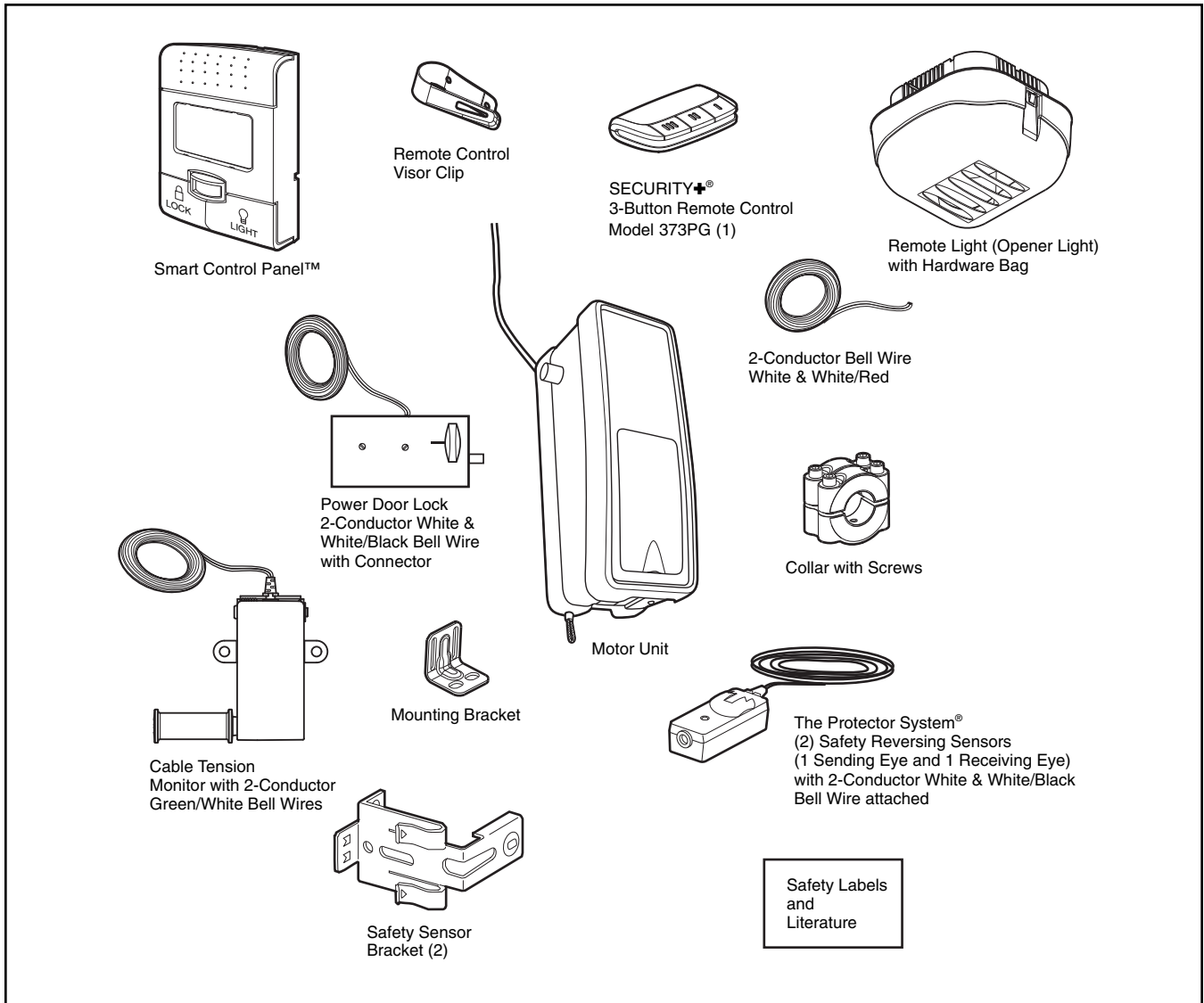

Hardware Inventory

INSTALLATION HARDWARE

- Hex Screw #14-10x1-7/8" (4)
- Screw #6x-1-1/4" (2)
- Machine Screw #6x1" (2)
- Carriage Bolt 1/4"-20x1/2" (2)
- Wing Nut 1/4"-20 (2)
- Pan Head Screw 1/4"-20x1/2" (2)
- Hex Head Screw #8x1" (2)

- Self Tapping Screw #10-32 (2)
- Drywall Anchor (2)
- Drywall Anchor (Screw-In) (2)
- Handle
- Rope
- Insulated Staples (30)
- Lock Template

ASSEMBLY STEP 1

Attach the Collar to the Motor Unit

To avoid installation difficulties, do not run the garage door opener until instructed to do so.

- Loosen the collar screws.
- Attach collar to either the left or the right side of the motor unit. Ensure that the collar is seated all the way on motor shaft until stop is reached (Figure 1).
- Position the collar so that the screws are facing up (accessible when attached to the torsion bar).
- Tighten both sides of collar screws equally to secure collar to the motor unit (12-14 ft./lbs. of torque) (Figure 2).

NOTE: For most installations the screws should be facing up for easy access. Do not tighten set screws until indicated.

ASSEMBLY STEP 2

Attach Mounting Bracket to Motor Unit

- Loosely attach slotted side of mounting bracket to the same side of the motor unit as the collar, using self-threading screws provided.

NOTE: Do not tighten until instructed. Illustrations shown are for left side installation.

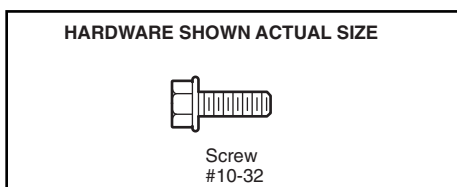

⚠ WARNING

To prevent possible SERIOUS INJURY or DEATH, the collar MUST be properly tightened. The door may not reverse correctly or limits may be lost due to collar slip.

Figure 1

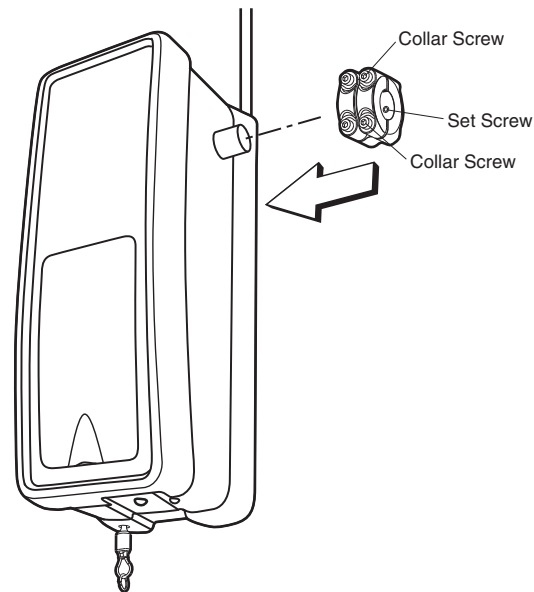
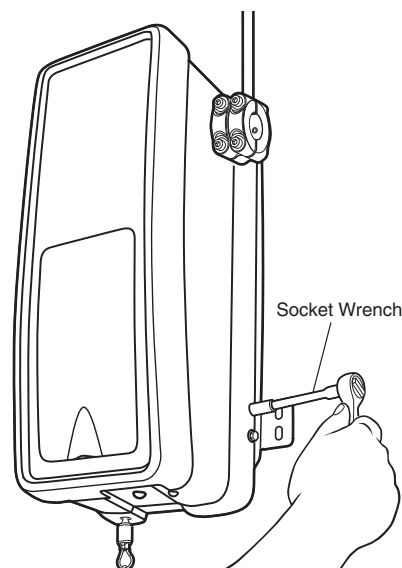
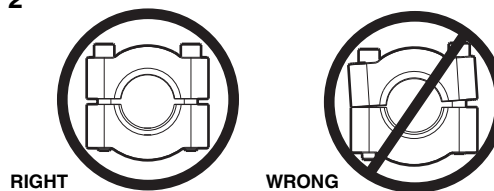

Figure 2



INSTALLATION

IMPORTANT INSTALLATION INSTRUCTIONS

WARNING

To reduce the risk of SEVERE INJURY or DEATH:

1. READ AND FOLLOW ALL INSTALLATION WARNINGS AND INSTRUCTIONS.
2. Install garage door opener ONLY on properly balanced and lubricated garage door. An improperly balanced door may not reverse when required and could result in SEVERE INJURY or DEATH.
3. ALL repairs to cables, spring assemblies and other hardware MUST be made by a trained door systems technician BEFORE installing opener.
4. Disable ALL locks and remove ALL ropes connected to garage door BEFORE installing opener to avoid entanglement.
5. Mount emergency release handle no higher than 6 feet (1.83 m) above floor.
6. NEVER connect garage door opener to power source until instructed to do so.
7. NEVER wear watches, rings or loose clothing while installing or servicing opener. They could be caught in garage door or opener mechanisms.
8. Install wall-mounted garage door control:
 - within sight of the garage door.
 - out of reach of children at minimum height of 5 feet (1.5 m).
 - away from ALL moving parts of the door.
9. Place entrapment warning label on wall next to garage door control.
10. Place manual release/safety reverse test label in plain view on inside of garage door.
11. Upon completion of installation, test safety reversal system. Door MUST reverse on contact with a 1-1/2" (3.8 cm) high object (or a 2x4 laid flat) on the floor.

INSTALLATION STEP 1

Position the Opener

NOTE: For additional mounting options see accessories page.

1. Close the garage door completely.
2. Slide the opener with collar over the end of the torsion bar. Ensure that the collar does not touch the bearing plate. Check to make sure the mounting bracket is located on a solid surface such as wood, concrete or door/flag bracket. Snug collar screws to help assure proper alignment of operator. Mark the bracket holes. It may be necessary to cut the torsion bar if it is too long or damaged.
3. Loosen collar screws from torsion bar and remove the opener. Drill 3/16" pilot holes at the marked locations. Drill through steel plate if needed.
4. Reinstall the opener by sliding the collar over the torsion bar until pilot holes align with bracket. Securely tighten collar screws that attach to the torsion bar to 12-14 ft./lbs. of torque. Securely tighten both set screws firmly, without damaging the motor unit.
5. Fasten bracket securely with 14-10x1-7/8" screws. Tighten all mounting bracket hardware.

NOTE: The motor unit does not have to be flush to wall.

6. Use a staple to secure the antenna wire to prevent antenna from being entangled in a door roller.

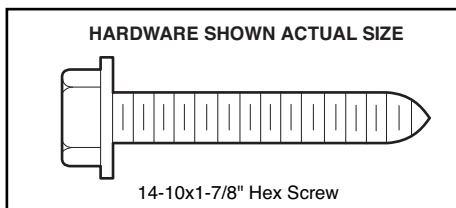

WARNING

To prevent possible SERIOUS INJURY or DEATH:

- Concrete anchors MUST be used if mounting bracket into masonry.
- NEVER try to loosen, move or adjust garage door, springs, cables, pulleys, brackets or their hardware, ALL of which are under EXTREME tension.
- ALWAYS call a trained door systems technician if garage door binds, sticks or is out of balance. An unbalanced garage door might not reverse when required.
- Operator MUST be mounted at a right angle to the torsion bar to avoid premature wear on the collar.

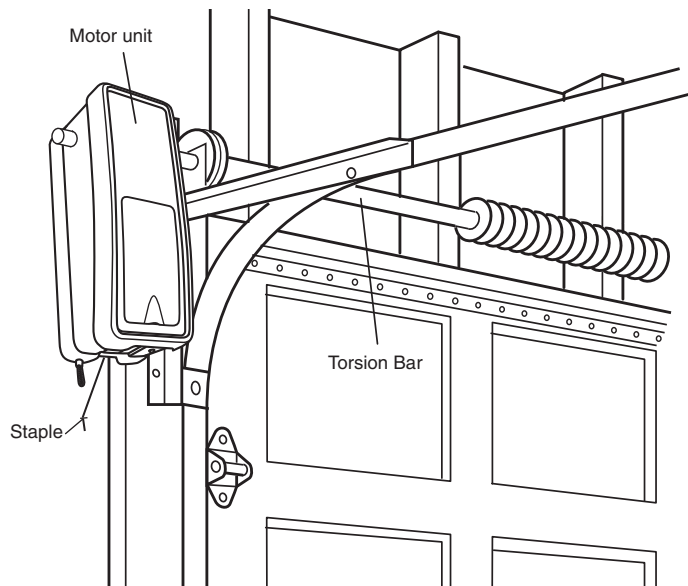

INSTALLATION STEP 2

Attach the Emergency Release Rope and Handle

- Thread one end of the rope through the hole in the top of the red handle so "NOTICE" reads right side up as shown. Secure with an overhand knot at least 1" (2.5 cm) from the end of the rope to prevent slipping.
- Thread the other end of the rope through the loop in the emergency release cable.
- Adjust rope length so the handle is no higher than 6' (1.83 m) above the floor. Secure with an overhand knot.

NOTE: If it is necessary to cut the rope, heat seal the cut end with a match or lighter to prevent unraveling.

⚠ WARNING

To prevent possible SERIOUS INJURY or DEATH from a falling garage door:

- If possible, use emergency release handle to disengage door ONLY when garage door is CLOSED. Weak or broken springs or unbalanced door could result in an open door falling rapidly and/or unexpectedly.
- NEVER use emergency release handle unless garage doorway is clear of persons and obstructions.

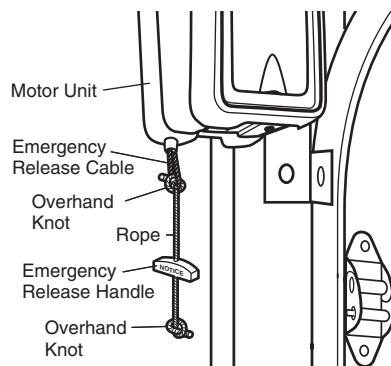

Figure 1

INSTALLATION STEP 3

Install Power Door Lock

The lock is used to prevent the garage door from being manually opened once the door is fully closed.

1. Select a door roller to mount the lock above. Check for clearance. If possible select a roller on the same side of the door as the motor unit. The second roller up from the bottom is ideal in most installations.
2. Ensure rail surface is clean and adhere lock template to achieve a 3" (7.6 cm) distance between the center of the roller and the pin hole (Figure 1).
3. Drill holes as marked on the template.
4. Fasten power door lock to the outside of the garage door track with hardware provided.
5. Run bell wire up wall to motor unit. Use insulated staples to secure wire in several places.
6. Plug connector into the motor unit (Figure 2).

NOTE: Lock must be mounted within 10' of the power head.

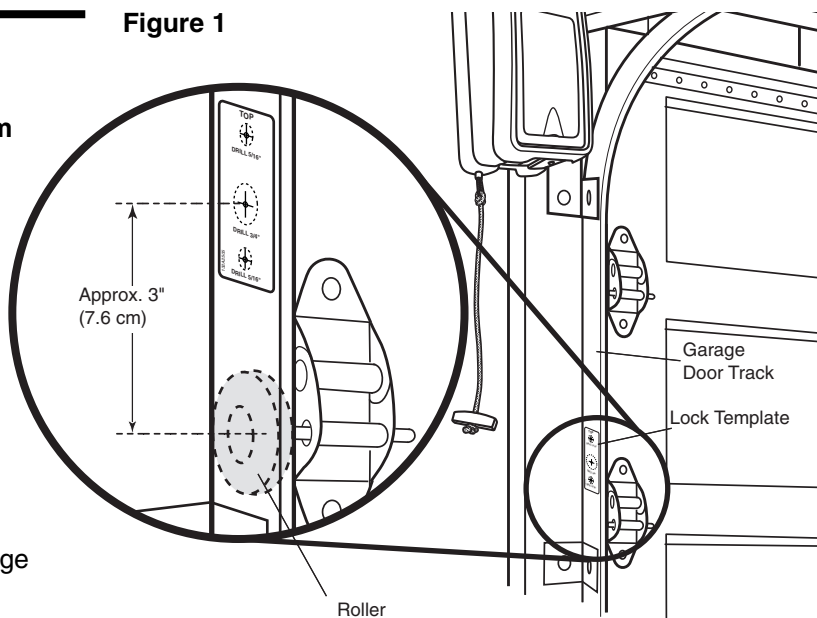
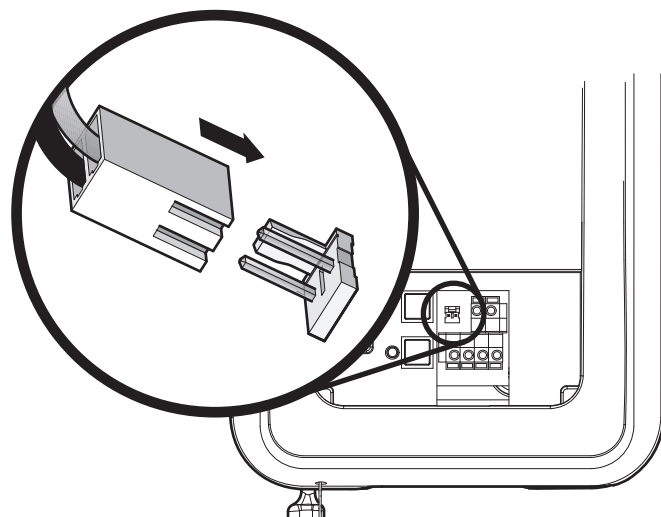
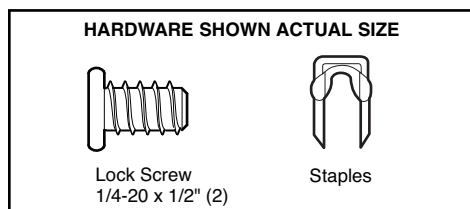

Figure 2



INSTALLATION STEP 4

Attach the Cable Tension Monitor (Required)

This opener comes standard with the cable tension monitor. It is supplied as a device to monitor the cables for ANY slack that may occur and will reverse the door when excessive slack is detected, eliminating service calls.

The cable tension monitor **MUST** be connected and properly installed before the garage door opener will move in the down direction.

NOTE: The cable tension monitor is shipped for left side installation. It is preferred that the cable tension monitor be installed on the same side of the door as the opener. If required, it can be mounted on the opposite side of the door. Remove the snap-ring holding the roller in place and reassemble it on the opposite side of the cable tension monitor.

1. Position the cable tension monitor as shown (Figures 1 and 2). The cable tension monitor should be located as close to the drum as possible.

NOTE: There must be no obstructions in the installation area that prevent the cable tension monitor or the cable itself from closing completely when slack is detected.

2. Make sure cable tension monitor is located over a wood support member.

NOTE: If the cable tension monitor can not be mounted into wood with the lag screws provided, it can be mounted into 1/2" or greater drywall using the wall anchors (2) and the #8 hex head screws (2) provided in the hardware bag.

3. Mark and drill 3/16" pilot holes for screws (pilot holes are not required for anchors).
4. Attach the cable tension monitor to the wall using the hardware provided. Make sure that the roller is on top of the cable.
5. Run bell wire to motor unit. Use insulated staples to secure wire in several places.
6. Connect bell wire to the green quick-connect terminals (polarity is not important) (Figure 3).

NOTE: Cable must have tension through entire travel. Make sure there is no slack in cable on opposite side of garage door during normal operation. If this condition exists, adjust cables as required.

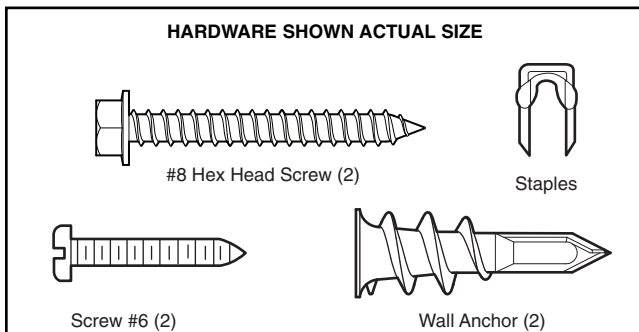

Figure 1

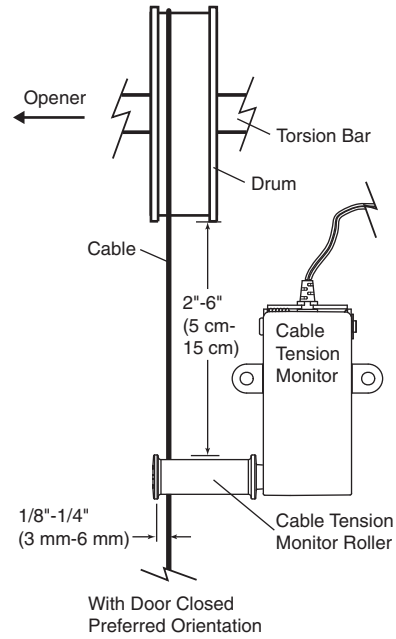

Figure 2

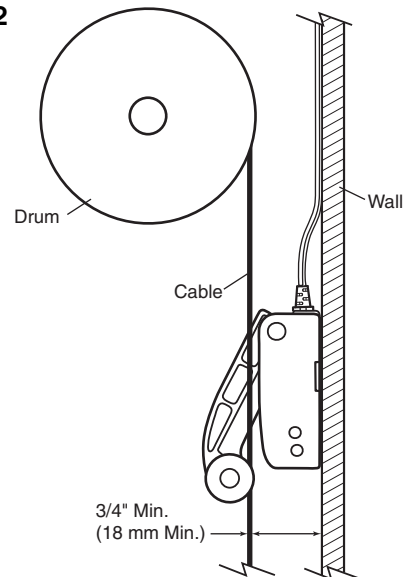
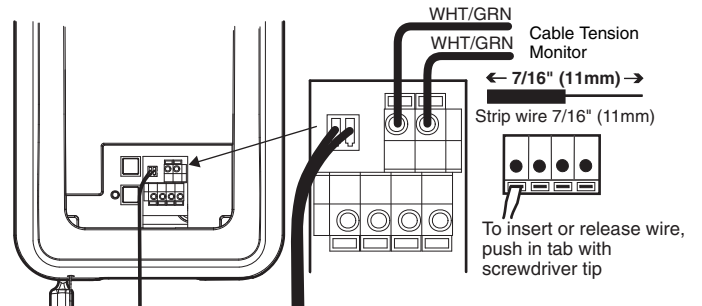

Figure 3



INSTALLATION STEP 5

Install the Door Control

Locate door control within sight of door, at a minimum height of 5' (1.5 m) where small children cannot reach, away from moving parts of door and door hardware. If installing into drywall, drill 5/32" holes and use the anchors provided. For pre-wired installations (as in new home construction), it may be mounted to a single gang box (Figure 1).

NOTE: The functional temperature range of the door control is between -20°C (-4°F) and +50°C (+122°F). Scroll speed of display is slower at lower temperatures although the door control remains fully functional.

CAUTION: Continuous exposure of the door control to temperatures below -22°F (-30°C) may damage the LCD screen.

SPECIAL NOTE: Only one 398LM can be connected to each garage door opener. If additional wall controls are desired to operate the same garage door opener, it is recommended to use model 378LM wireless wall control as the secondary door control.

- Strip 7/16" (11 mm) of insulation from one end of bell wire and connect to the two screw terminals on back of door control by color: white wire to the W (2) and white/red wire to the R (1) (Figure 2).
- Remove push bar cover by gently prying at the lower/middle portion of the cover with a small flat-head screwdriver. Fasten with 6AB x 1-1/4" self-tapping screws (drywall installation) or 6-32 x 1" machine screws (into gang box) as follows:
 - Install bottom screw, allowing 1/8" (3 mm) to protrude above wall surface.
 - Position bottom of door control on screw head and slide down to secure. Adjust screw for snug fit.
 - Drill and install top screw with care to avoid cracking plastic housing. **Do NOT overtighten.**
 - Replace cover by inserting top tabs first and then snap cover in place.
- (For standard installations ONLY)** Run bell wire up wall and across ceiling to motor unit. Use insulated staples to secure wire in several places. Do NOT pierce wire with a staple, creating a short or open circuit.
- Strip 7/16" (11 mm) of insulation from end of bell wire. Connect bell wire to the quick-connect terminals on the motor unit: white to white and white/red to red (Figure 3).

NOTE: DO NOT connect the power and operate the opener at this time. The door will travel to the full open position but will not return to the close position until the sensor beams are connected and properly aligned. See page 14.

⚠️ WARNING

To prevent possible SERIOUS INJURY or DEATH from electrocution:

- Be sure power is not connected BEFORE installing door control.
- Connect ONLY to 24 VOLT low voltage wires.

To prevent possible SERIOUS INJURY or DEATH from a closing garage door:

- Install door control within sight of garage door, out of reach of children at a minimum height of 5 feet (1.5 m) and away from ALL moving parts of door.
- NEVER permit children to operate or play with door control push buttons or remote controls.
- Activate door ONLY when it can be seen clearly, is properly adjusted and there are no obstructions to door travel.
- ALWAYS keep garage door in sight until completely closed. NEVER permit anyone to cross path of closing garage door.

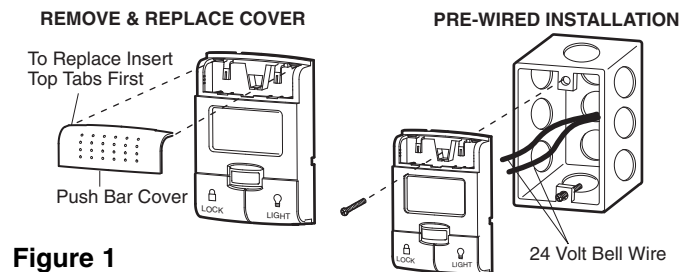
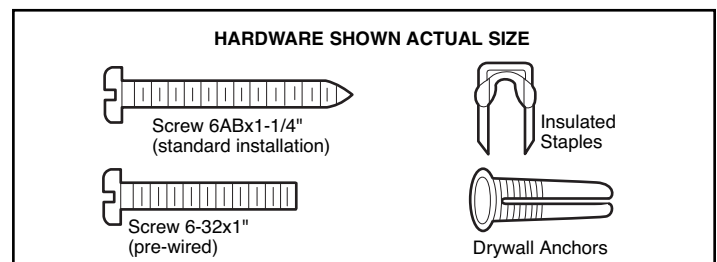

Figure 1

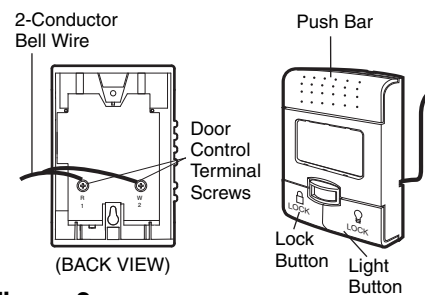

Figure 2

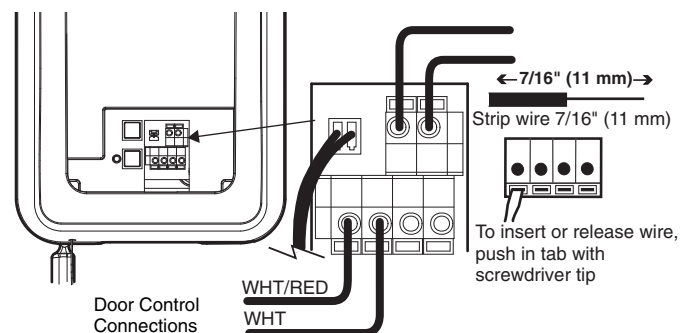

Figure 3

IMPORTANT SAFETY INSTRUCTIONS

⚠️ ⚠️ WARNING

To reduce the risk of SEVERE INJURY or DEATH:

1. This portable luminaire has a polarized plug (one blade is wider than the other) as a feature to reduce the risk of electric shock.
2. This plug will fit in a polarized outlet ONLY one way.
3. If the plug does not fit fully in the outlet, reverse the plug.
4. If it still does not fit, contact a qualified electrician.
5. NEVER use with an extension cord unless plug can be fully inserted.
6. DO NOT alter the plug.
7. Light is intended for ceiling mount and indoor applications ONLY.

INSTALLATION STEP 6

Install the Light

The remote light (opener light) is designed to plug directly into a standard 120V outlet.

1. Install the hinge and latch clips. Clips slide in between the metal plate and the plastic housing on each side of the light base (Figure 1).
2. Select an appropriate location on the ceiling to mount the light within 6' (1.8 m) of an electrical outlet so that the cord and light are away from moving parts.
3. Install the ceiling mount plate with the screws provided. Leave 1/8" (3.1 mm) of the thread exposed between the ceiling and the screw head (Figure 2).

NOTE: If installing remote light (opener light) on drywall and a ceiling joist can not be located, use wall anchors provided. No pilot hole is required for wall anchors.

4. Determine the length of power cord needed to reach the nearest outlet. Wind any excess cord around cord retainer on the top side of the light base.
5. Install the light base by pushing onto the screws and turning the base clockwise to lock the light in place.
6. Install two Type A19 incandescent or compact fluorescent bulbs. 100 watt maximum per bulb, 200 watts total.
7. Install the light lens by hooking one end of the lens over the hinge and pressing up on the other end to latch into place (Figure 3).
8. Plug in the light to outlet.

NOTE: Light will not operate until the unit is activated.

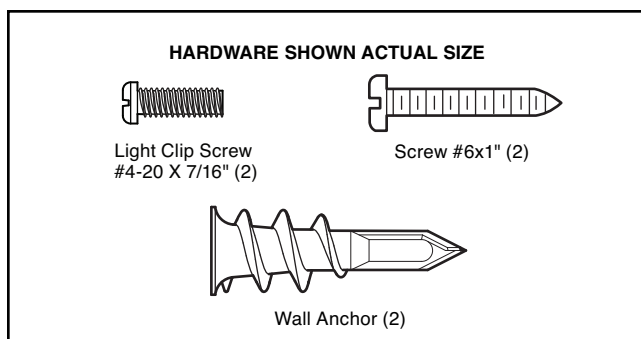

CAUTION

To prevent possible OVERHEATING of the endpanel or light socket:

- DO NOT use short neck or specialty light bulbs.
- DO NOT use halogen bulbs. Use ONLY incandescent.

To prevent damage to the opener:

- DO NOT use bulbs larger than 100W.
- ONLY use A19 size bulbs.

Figure 1

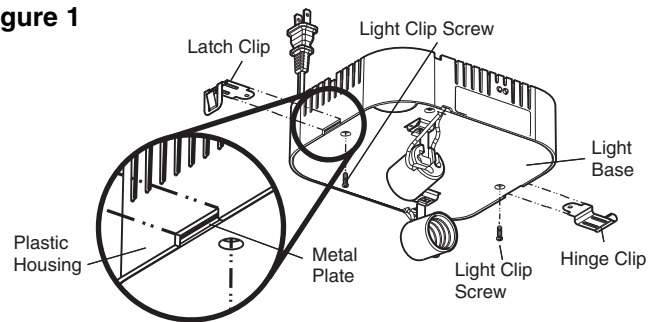

Figure 2

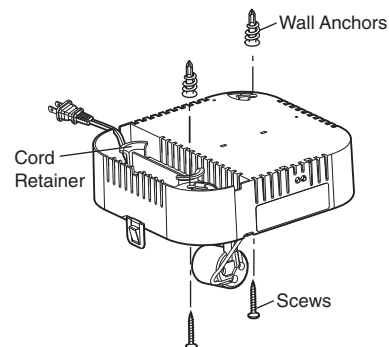
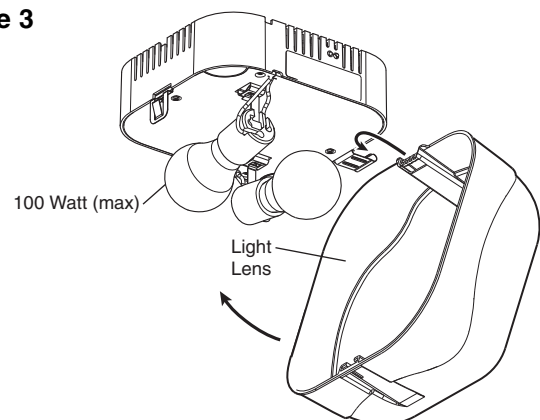

Figure 3



INSTALLATION STEP 7

Electrical Requirements

To avoid installation difficulties, do not run the opener at this time.

To reduce the risk of electric shock, your garage door opener has a grounding type plug with a third grounding pin. This plug will only fit into a grounding type outlet. If the plug doesn't fit into the outlet you have, contact a qualified electrician to install the proper outlet.

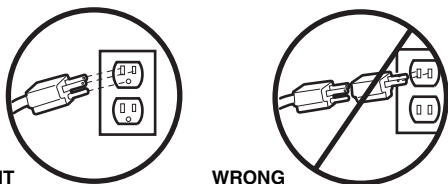

If permanent wiring is required by your local code, refer to the following procedure.

To make a permanent connection through the 7/8" hole in the back of the motor unit (according to local code):

- Remove the opener from the torsion bar, remove cover screws and set the cover aside.
- Remove the attached green ground terminal.
- Cut black and white wires and strip away 1/2" (1.3 cm) of insulation, 3" (7.6 cm) before spade terminals.
- Remove the power cord from unit.
- Install a 90° conduit or flex cable adapter to the 7/8" hole. Reinstall opener to torsion bar.
- Run wires through conduit, cut to proper length and strip insulation.
- Attach with wire nuts provided.
- Properly secure wire under plastic ties so that wire does not come in contact with moving parts.
- Reinstall the cover.

To avoid installation difficulties, do not run the opener at this time.

⚠ WARNING

To prevent possible SERIOUS INJURY or DEATH from electrocution or fire:

- Be sure power is not connected to the opener, and disconnect power to circuit BEFORE removing cover to establish permanent wiring connection.
- Garage door installation and wiring MUST be in compliance with ALL local electrical and building codes.
- NEVER use an extension cord, 2-wire adapter or change plug in any way to make it fit outlet. Be sure the opener is grounded.

PERMANENT WIRING CONNECTION

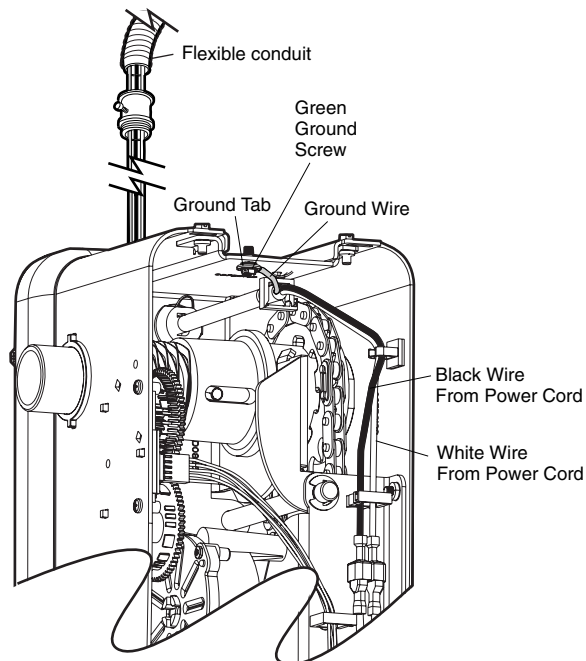

PERMANENT WIRING CONNECTION

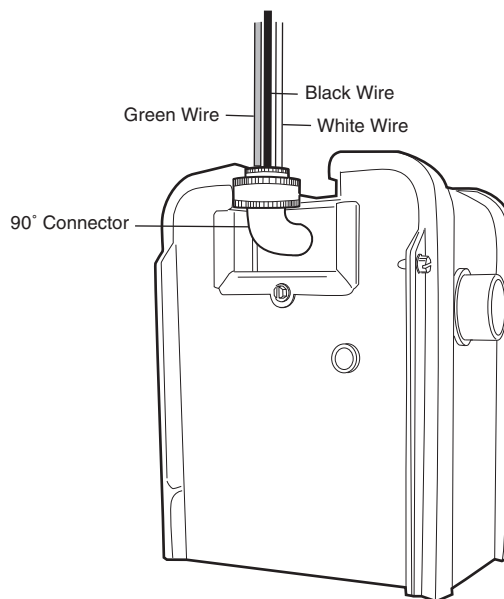

INSTALLATION STEP 8

Mount the Standby Power Unit (SPU) (not provided)

If the optional 475RGD Standby Power Unit is part of this installation it should be installed at this time.

- The SPU can be mounted to either the ceiling or a wall within 3' (.9 m) of the motor unit.
- Position the SPU as desired to a structural support (ceiling joist or wall stud).
- Attach the SPU to the support using the mounting holes on either side of the SPU.
- Secure the SPU using the 1-1/2" lag screws (2) provided with the SPU unit.
- Connect the SPU cord into the connector on the bottom of the motor unit.
- Follow all instructions included with the 475RGD unit to test for proper operation and testing of the SPU.

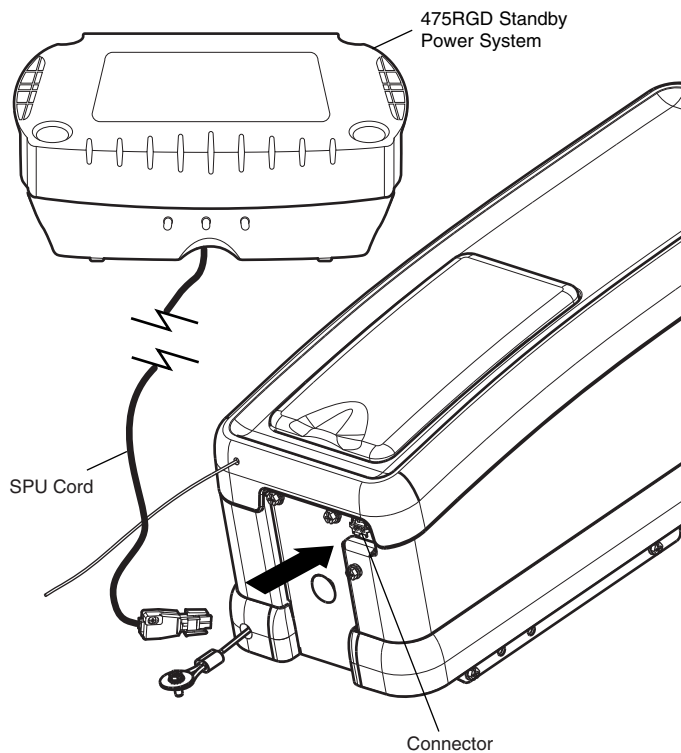

INSTALLATION STEP 9

Install The Protector System®

The safety reversing sensor *must* be connected and aligned correctly before the garage door opener will move in the down direction. This is a required safety device and cannot be disabled.

IMPORTANT INFORMATION ABOUT THE SAFETY REVERSING SENSOR

When properly connected and aligned, the safety reversing sensor will detect an obstacle in the path of its electronic beam. The sending eye (with an amber indicator light) transmits an invisible light beam to the receiving eye (with a green indicator light). If an obstruction breaks the light beam while the door is closing, the door will stop and reverse to full open position, and the opener lights will flash 10 times.

The units must be installed inside the garage so that the sending and receiving eyes face each other across the door, no more than 6" (15 cm) above the floor. Either can be installed on the left or right of the door as long as the sun never shines directly into the receiving eye lens.

The mounting brackets are designed to clip onto the track of sectional garage doors without additional hardware.

⚠ WARNING

Be sure power is not connected to the garage door opener BEFORE installing the safety reversing sensor.

To prevent SERIOUS INJURY or DEATH from a closing garage door:

- Correctly connect and align the safety reversing sensor. This required safety device **MUST NOT** be disabled.
- Install the safety reversing sensor so beam is **NO HIGHER** than 6" (15 cm) above garage floor.

If it is necessary to mount the units on the wall, the brackets must be securely fastened to a solid surface such as the wall framing. Extension brackets (see Accessories) are available if needed. If installing in masonry construction, add a piece of wood at each location to avoid drilling extra holes in masonry if repositioning is necessary.

The invisible light beam path must be unobstructed. No part of the garage door (door tracks, springs, hinges, rollers or other hardware) may interrupt the beam while the door is closing.

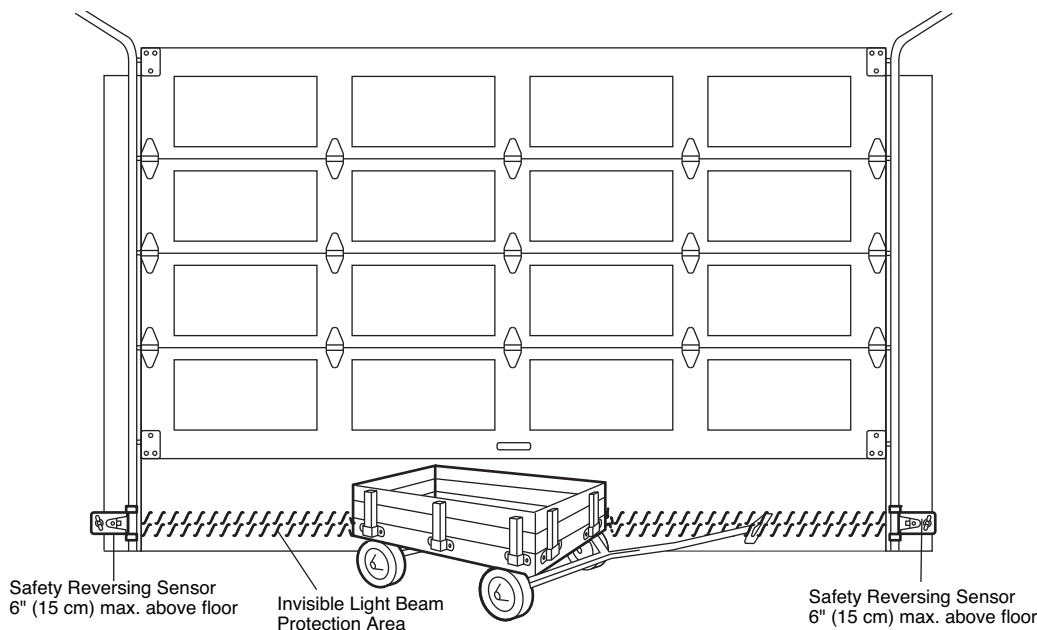

Facing the door from inside the garage

INSTALLING THE BRACKETS

Be sure power to the opener is disconnected. Install and align the brackets so the safety reversing sensors will face each other across the garage door, with the beam no higher than 6" (15 cm) above the floor. They may be installed in one of three ways, as follows.

Garage door track installation (preferred) (Figure 1):

- Slip the curved arms over the rounded edge of each door track, with the curved arms facing the door. Snap into place against the side of the track. It should lie flush, with the lip hugging the back edge of the track, as shown in Figure 1.

If your door track will not support the bracket securely, wall installation is recommended.

Wall installation (Figure 2 and 3):

- Place the bracket against the wall with curved arms facing the door. Be sure there is enough clearance for the sensor beam to be unobstructed.
- If additional depth is needed, an extension bracket (see Accessories) or wood blocks can be used.
- Use bracket mounting holes as a template to locate and drill (2) 3/16" diameter pilot holes on the wall at each side of the door, no higher than 6" (15 cm) above the floor.
- Attach brackets to wall with lag screws (not provided).
- If using extension brackets or wood blocks, adjust right and left assemblies to the same distance out from the mounting surface. Make sure all door hardware obstructions are cleared.

Floor installation (Figure 4):

- Use wood blocks or extension brackets (see Accessories) to elevate sensor brackets so the lenses will be no higher than 6" (15 cm) above the floor.
- Carefully measure and place right and left assemblies at the same distance out from the wall. Be sure all door hardware obstructions are cleared.
- Fasten to the floor with concrete anchors as shown.

Figure 1 DOOR TRACK MOUNT (RIGHT SIDE)

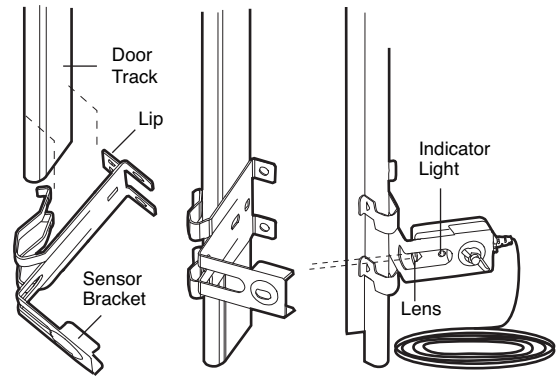

Figure 2

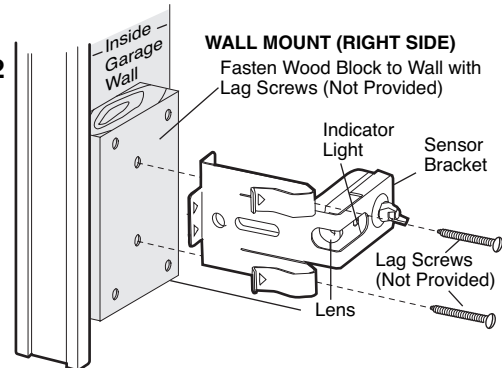

Figure 3

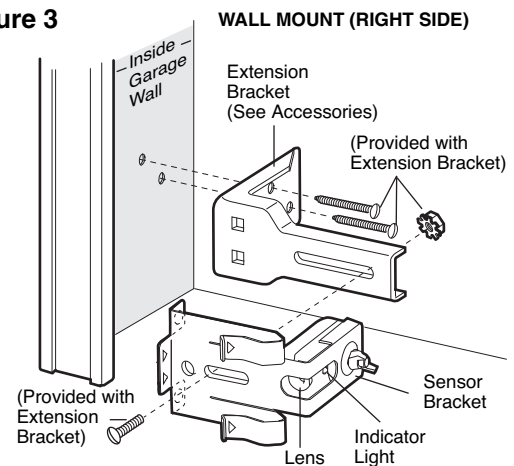
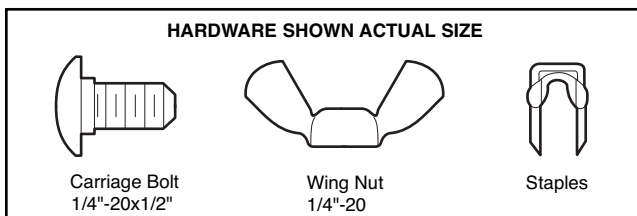
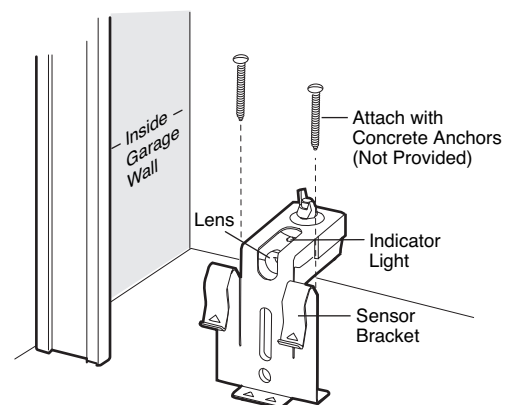

Figure 4

FLOOR MOUNT (RIGHT SIDE)



MOUNTING AND WIRING THE SAFETY REVERSING SENSORS

- Slide a 1/4"-20x1/2" carriage bolt head into the slot on each sensor. Use wing nuts to fasten safety reversing sensors to brackets, with lenses pointing toward each other across the door. Be sure the lens is not obstructed by a bracket extension (Figure 5).
- Finger tighten the wing nuts.
- Run the wires from both safety reversing sensors to the opener. Use insulated staples to secure wire to wall and ceiling.
- Strip 7/16" (11 mm) of insulation from each set of wires. Separate white and white/black wires sufficiently to connect to the opener quick-connect terminals: white to white and white/black to grey (Figure 6).

ALIGNING THE SAFETY REVERSING SENSORS

- Plug in the opener. The indicator lights in both the sending and receiving eyes will *glow steadily* if wiring connections and alignment are correct.

The *sending eye* amber indicator light will glow regardless of alignment or obstruction. If the green indicator light in the *receiving eye* is off, dim, or flickering (and the invisible light beam path is not obstructed), alignment is required.

- Loosen the *sending eye* wing nut and readjust, aiming directly at the *receiving eye*. Lock in place.
- Loosen the *receiving eye* wing nut and adjust the safety reversing sensor until it receives the sender's beam. When the green indicator light *glows steadily*, tighten the wing nut.

Figure 5

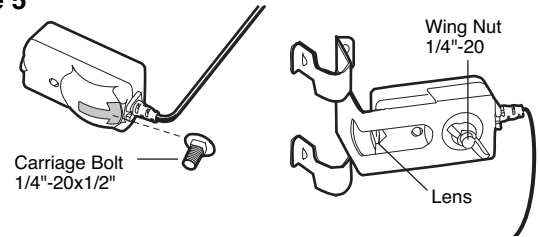

TROUBLESHOOTING THE SAFETY REVERSING SENSORS

1. If the *sending eye* indicator light does not *glow steadily* after installation, check for:
 - Electric power to the opener.
 - A short in the white or white/black wires. These can occur at staples, or at opener connections.
 - Incorrect wiring between safety reversing sensors and opener.
 - A broken wire.
2. If the *sending eye* indicator light *glows steadily* but the *receiving eye* indicator light doesn't:
 - Check alignment.
 - Check for an open wire to the *receiving eye*.
3. If the *receiving eye* indicator light is dim, realign either sensor.

NOTE: When the invisible beam path is obstructed or misaligned while the door is closing, the door will reverse. If the door is already open, it will not close. The remote lights will blink 10 times. (If bulbs are not installed, 10 clicks can be heard.) See page 11.

Figure 6

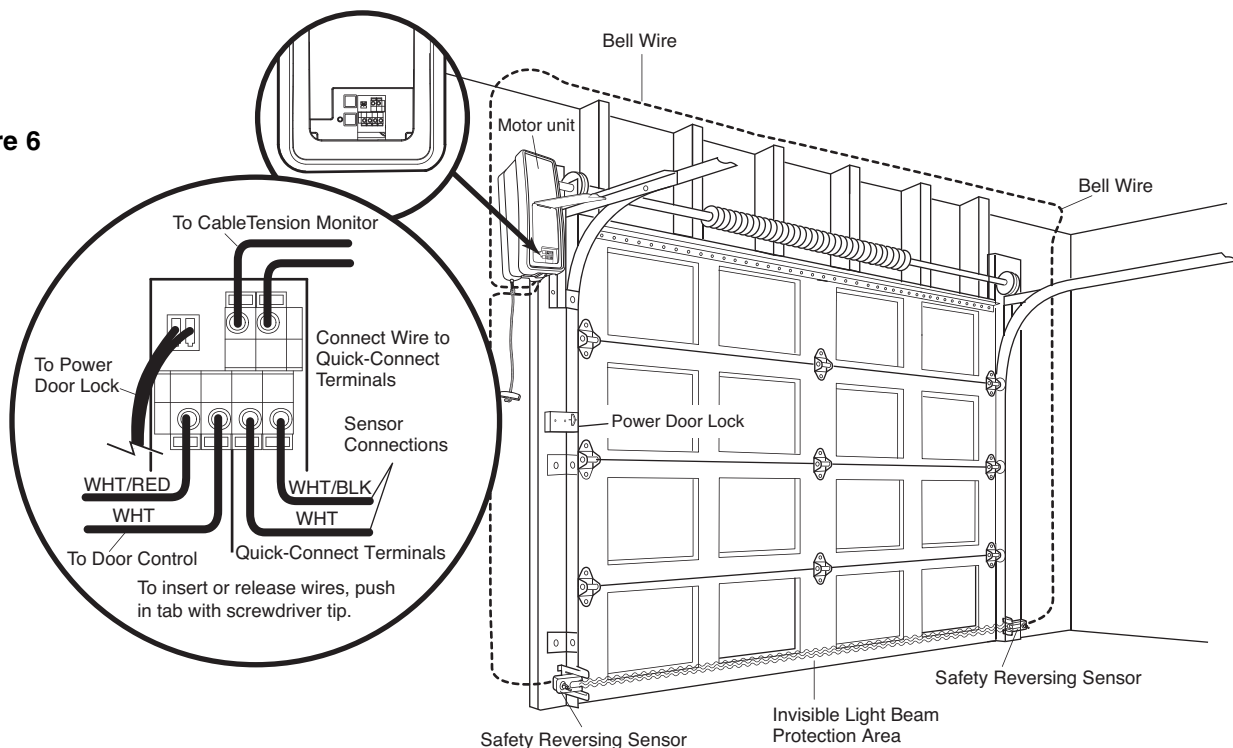

ADJUSTMENT STEP 1

Program the Travel Limits

Travel limits regulate the points at which the door will stop when moving up or down. Follow the steps below to set the limits.

Figure 1

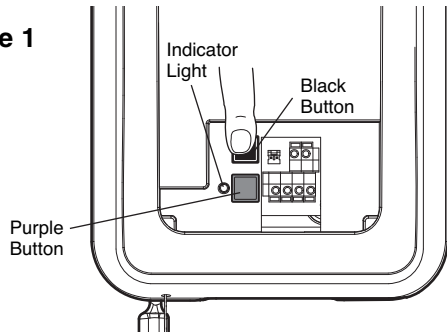

To program the travel limits:

Adjust the position of the door by using the black and purple buttons. Black moves the door UP (open) and purple moves the door DOWN (close).

1. **Setting the UP position:** Press and hold the black button until the yellow indicator light starts flashing slowly then release.
2. Push and hold the black button until the door reaches the desired UP (open) position (Figure 2).

NOTE: Check to be sure the door opens high enough for your vehicle.

3. Push the remote control or door control (Figure 3). This sets the UP (open) limit and begins closing the door.

NOTE: Excessive movement of the motor unit will cause premature wear. See Troubleshooting section.

4. Immediately when the door begins to move down, press and release either the black or purple button. This will stop the door.
5. **Setting the DOWN position:** Push and hold the purple button until the door reaches the desired DOWN (closed) position (Figure 4).
6. Once the door is closed, check for proper pressure on the door (you should be able to manually push the door down a 1/16 of an inch). If there appears to be too much pressure on the door, you may toggle the door back and forth using the black and purple buttons to reach the desired position.
7. Push the remote control or the door control (Figure 3). This sets the DOWN (close) limit and should bring the door to the open position.
 - If the opener is not stopping exactly where you would like it, repeat steps 1 through 7 and program the limits again.
 - When the unit stops in both the desired up (open) and down (close) positions, proceed to *Adjustment Step 2, Setting the Force*.

WARNING

Without a properly installed safety reversal system, persons (particularly small children) could be SERIOUSLY INJURED or KILLED by a closing garage door.

- NEVER learn forces or limits when door is binding or sticking. Repair door first.
- Incorrect adjustment of garage door travel limits will interfere with proper operation of safety reversal system.
- After ANY adjustments are made, the safety reversal system MUST be tested. Door MUST reverse on contact with 1-1/2" high (3.8 cm) object (or 2x4 laid flat) on floor.

CAUTION

To prevent damage to vehicles, be sure fully open door provides adequate clearance.

Figure 2

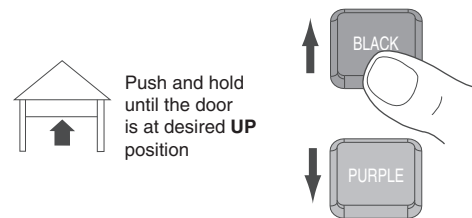

Figure 3

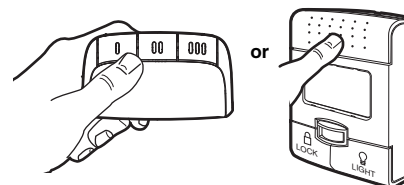
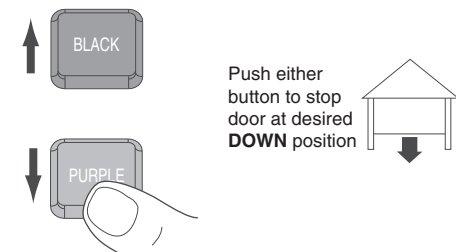

Figure 4



ADJUSTMENT STEP 2

Setting the Force

The force setting button is located on the front panel. The force setting measures the amount of force required to open and close the door.

1. Locate the purple button on the unit (Figure 1).
2. Push the purple button twice to enter unit into Force Adjustment Mode (Figure 2). The LED (Indicator Light) will flash quickly.
3. Push the remote control or door control (Figure 3). The door will travel to the DOWN (close) position. Push the remote control or door control again, the door will travel to the UP (open) position. Push the remote control or door control a third time to send the door to the DOWN (close) position.

The LED (Indicator Light) will stop flashing when the force has been learned.

The unit has learned the forces required to open and close your door.

The door must travel through a complete cycle, UP and DOWN, in order for the force to be set properly. If the unit cannot open and close your door fully, inspect your door to insure that it is balanced properly and is not sticking or binding. See page 4, "Preparing your garage door."

⚠ WARNING

Without a properly installed safety reversal system, persons (particularly small children) could be SERIOUSLY INJURED or KILLED by a closing garage door.

- NEVER learn forces or limits when door is binding or sticking. Repair door first
- Too much force on garage door will interfere with proper operation of safety reversal system.
- After ANY adjustments are made, the safety reversal system MUST be tested. Door MUST reverse on contact with 1-1/2" high (3.8 cm) object (or 2x4 laid flat) on floor.

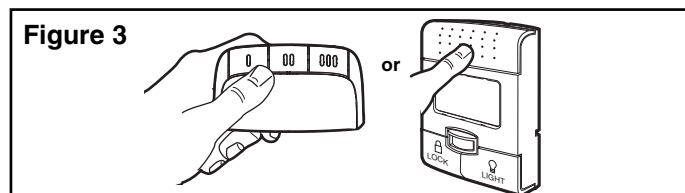
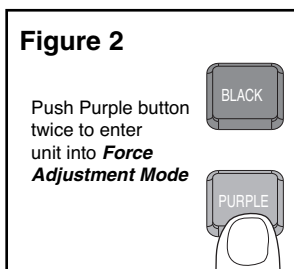
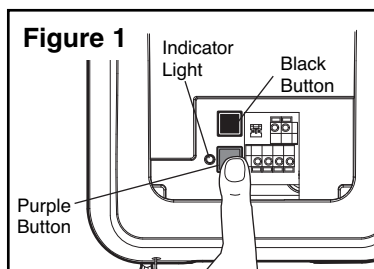

ADJUSTMENT STEP 3

Test the Safety Reversal System

TEST

- With the door fully open, place a 1-1/2" (3.8 cm) board (or a 2x4 laid flat) on the floor, centered under the garage door.
- Operate the door in the down direction. The door **must** reverse on striking the obstruction. Upon successful safety reversal test proceed to *Adjustment Step 4*.

ADJUST

- If the door stops on the obstruction, it is not traveling far enough in the down direction. Complete Adjustment Steps 1 and 2 Programming the Limits and Forces.
- Repeat the test.
- When the door reverses on the 1-1/2" (3.8 cm) board (or 2x4 laid flat), remove the obstruction and run the opener through 3 or 4 complete travel cycles to test adjustment.
- If the unit continues to fail the Safety Reverse Test, call for a trained door systems technician.

IMPORTANT SAFETY CHECK:

Test the Safety Reverse System after:

- Each adjustment of limits, or force controls.
- Any repair to or adjustment of the garage door (including springs and hardware).
- Any repair to or buckling of the garage floor.
- Any repair to or adjustment of the opener.

ADJUSTMENT STEP 4

Test The Protector System®

- Press the remote control push button to open the door.
- Place the opener carton in the path of the door.
- Press the remote control push button to close the door. The door will not move more than an inch, and the opener lights will flash.

The garage door opener will not close from a remote if the indicator light in either sensor is off (alerting you to the fact that the sensor is misaligned or obstructed).

If the opener closes the door when the safety reversing sensor is obstructed, do not operate the door. Call for a trained door systems technician.

⚠ WARNING

Without a properly installed safety reversal system, persons (particularly small children) could be **SERIOUSLY INJURED** or **KILLED** by a closing garage door.

- Safety reversal system **MUST** be tested every month.
- If one control (force or travel limits) is adjusted, the other control may also need adjustment.
- After **ANY** adjustments are made, the safety reversal system **MUST** be tested. Door **MUST** reverse on contact with 1-1/2" (3.8 cm) high object (or 2x4 laid flat) on the floor.

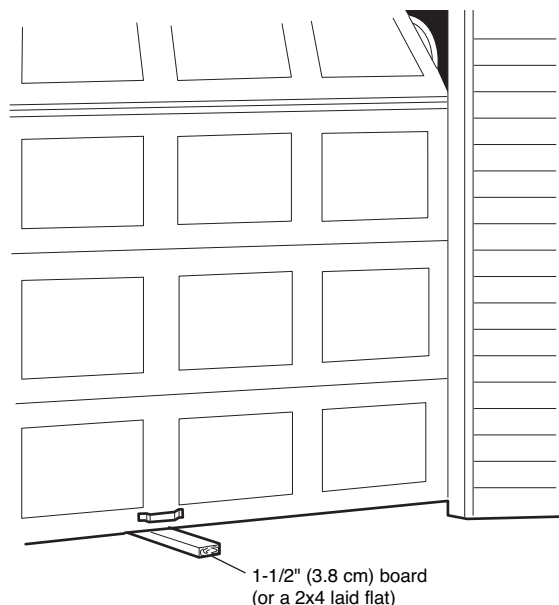

⚠ WARNING

Without a properly installed safety reversing sensor, persons (particularly small children) could be **SERIOUSLY INJURED** or **KILLED** by a closing garage door.

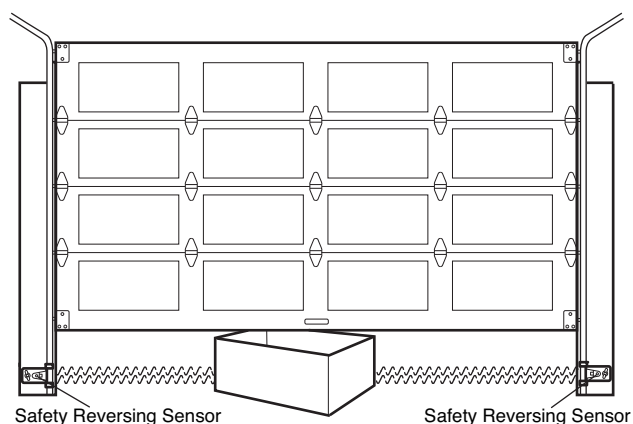

ADJUSTMENT STEP 5

Test Cable Tension Monitor

If your cable tension monitor has been activated the Indicator Light will blink 9 times. See page 18.

ADJUSTMENT STEP 6

Test Power Door Lock

TEST

- With the door fully closed, the power door lock bolt should be protruding through the track.
- Operate the door in the open direction. The power door lock should retract before the door begins to move.
- Operate the door in the down direction. When the door reaches the fully closed position, the power door lock should automatically activate to secure the door.

NOTE: If the power door lock does not function, the lock can be manually released by sliding the manual release handle to the open position.

ADJUSTMENT STEP 7

To Open the Door Manually

Disengage door lock before proceeding. The door should be fully closed if possible. Pull down on the emergency release handle until a click noise is heard from the unit and lift the door manually. To reconnect the door to the opener, pull down the emergency release handle straight down a second time until a click noise is heard from the unit. The door will reconnect on the next UP or DOWN operation.

Test the emergency release:

- Make sure the garage door is closed.
- Pull the emergency release handle. The garage door should then be able to be opened manually.
- Return the door to the closed position.
- Pull the emergency handle a second time.
- Reconnect the door to the opener.

⚠ WARNING

To prevent possible SERIOUS INJURY or DEATH from a falling garage door:

- If possible, use emergency release handle to disengage door ONLY when garage door is CLOSED. Weak or broken springs or unbalanced door could result in an open door falling rapidly and/or unexpectedly.
- NEVER use emergency release handle unless garage doorway is clear of persons and obstructions.

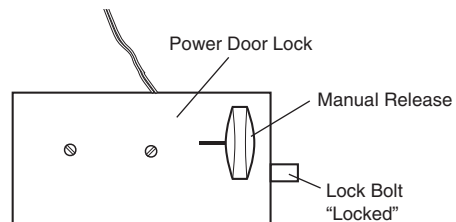
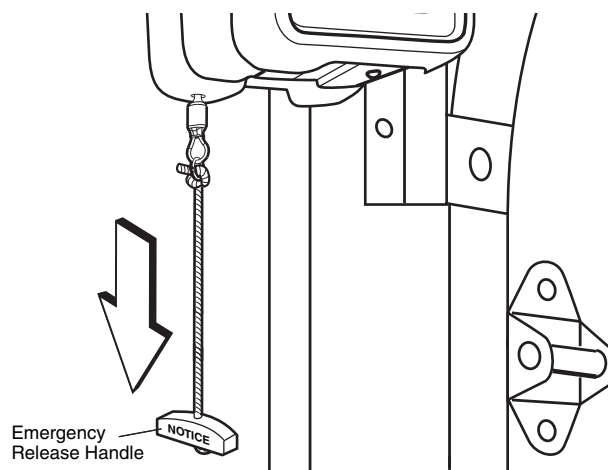

OPERATION

IMPORTANT SAFETY INSTRUCTIONS

WARNING

To reduce the risk of SEVERE INJURY or DEATH:

1. READ AND FOLLOW ALL WARNINGS AND INSTRUCTIONS.
2. ALWAYS keep remote controls out of reach of children. NEVER permit children to operate or play with garage door control push buttons or remote controls.
3. ONLY activate garage door when it can be seen clearly, it is properly adjusted and there are no obstructions to door travel.
4. ALWAYS keep garage door in sight until completely closed. NO ONE SHOULD CROSS THE PATH OF THE MOVING DOOR.
5. NO ONE SHOULD GO UNDER A STOPPED, PARTIALLY OPENED DOOR.
6. If possible, use emergency release handle to disengage door ONLY when garage door is CLOSED. Weak or broken springs or unbalanced door could result in an open door falling rapidly and/or unexpectedly.
7. NEVER use emergency release handle unless garage doorway is clear of persons and obstructions.
8. After ANY adjustments are made, the safety reversal system MUST be tested.
9. Safety reversal system MUST be tested every month. Garage door MUST reverse on contact with 1-1/2" (3.8 cm) high object (or a 2x4 laid flat) on the floor.
10. ALWAYS KEEP GARAGE DOOR PROPERLY BALANCED (see page 3). An improperly balanced door may not reverse when required and could result in SEVERE INJURY or DEATH.
11. ALL repairs to cables, spring assemblies and other hardware, ALL of which are under EXTREME tension, MUST be made by a trained door systems technician.
12. ALWAYS disconnect electric power to garage door opener BEFORE making ANY repairs or removing covers.
13. **SAVE THESE INSTRUCTIONS.**

Using Your Garage Door Opener

Your **SAFETY SIGNAL™** opener and hand-held remote control have been factory-set to a matching code which changes with each use, randomly accessing over 100 billion new codes. Your opener will operate with up to eight **SAFETY SIGNAL™** remote controls and one **SAFETY SIGNAL™** Keyless Entry System. If you purchase a new remote, or if you wish to deactivate any remote, follow the instructions in the *Programming* section.

Activate your opener with any of the following:

- *The hand-held Remote Control:* Hold the large push button down until the door starts to move.
- *The wall-mounted Door Control:* Hold the push button or bar down until the door starts to move.
- *The Keyless Entry (See Accessories):* If provided with your garage door opener, it must be programmed before use. See *Programming*.

When the opener is activated (with the safety reversing sensor correctly installed and aligned)

1. If open, the door will close. If closed, it will open.
2. If closing, the door will reverse.
3. If opening, the door will stop.
4. If the door has been stopped in a partially open position, it will close.
5. If obstructed while closing, the door will reverse. If the obstruction interrupts the sensor beam, the opener lights will blink for five seconds.

6. If obstructed while opening, the door will stop.
7. If fully open, the door will not close when the beam is broken. The sensor has no effect in the opening cycle.

If the sensor is not installed, or is misaligned, the door won't close from a hand-held remote. However, you can close the door with the Door Control, the Outside Keylock, or Keyless Entry, *if you activate them until down travel is complete*. If you release them too soon, the door will reverse.

The opener lights will turn on when the opener is activated. They will turn off automatically after 4-1/2 minutes or provide constant light when the Light feature on the Smart Control Panel™ is activated. Bulb size is A19. Bulb power is 100 watts maximum.

SAFETY SIGNAL™ light feature: Lights will also turn on when someone walks through the open garage door. With a Smart Control Panel™, this feature may be turned off as follows: With the opener lights off, press and hold the light button for 10 seconds, until the light goes on, then off again. To restore this feature, start with the opener lights on, then press and hold the light button for 10 seconds until the light goes off, then on again.

Using the Wall-Mounted Door Control

THE SMART CONTROL PANEL™

Press the push bar to open or close the door. Press again to reverse the door during the closing cycle or to stop the door while it's opening.

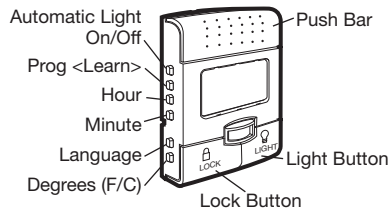

This door control contains a motion sensing detector that will automatically turn on the light when it detects a person entering the garage.

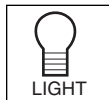

Light feature

Press the Light button to turn the opener light on or off. It will not control the opener lights when the door is in motion. If you turn it on and then activate the opener, the light will remain on for 4-1/2 minutes. Press again to turn it off sooner. The 4-1/2 minute interval can be changed to 1-1/2, 2-1/2, or 3-1/2 minutes as follows: Press and hold the Lock button until the light blinks (about 10 seconds). A single blink indicates that the timer is reset to 1-1/2 minutes. Repeat the procedure and the light will blink twice, resetting the timer to 2-1/2 minutes. Repeat again for a 3-1/2 minute interval, etc., up to a maximum of four blinks and 4-1/2 minutes.

When using the opener lights as working lights, we recommend that you first disable the motion sensor. See *Automatic Light Feature*, below.

Motion Sensing (Automatic Light Feature): The opener light will turn on automatically when a person enters the garage. When a person walks in front of the door control, the light will come on for five minutes, then shut off. This feature works by detecting body heat.



To disable this feature, push the motion sensing button on the side of the door control.

We recommend that you disable the motion sensor when using the opener lights as working lights. Otherwise, they will turn off automatically if you are working beyond the sensors range.

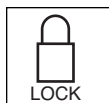

Lock feature

Designed to prevent operation of the door from hand-held remote controls. However, the door will open and close from the Door Control, the Outdoor Key Switch and the Keyless Entry Accessories.

To activate, press and hold the Lock button for 2 seconds. To turn off, press and hold the Lock button again for 2 seconds. The Lock feature will also turn off whenever the "learn" button on the motor unit panel is activated.

(PROG) Learn Feature

The door control is equipped with a Prog <LEARN> button to assist in learning remote controls to the unit. Press the Prog <LEARN> button once to initiate LEARN mode and the display will show 'Learn Remote Control - Press Learn Button Again to Confirm'. Press the Prog <LEARN> button a second time and the display will show 'Learn Mode - Press Remote Control Button to Learn Remote.' Press the button of the remote control to be learned and the worklight will blink to confirm the remote control has been learned.

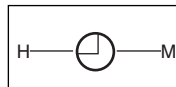

Hour & Minute Feature

Press or hold either of these side buttons to increment the hour or minute displayed on the LCD display.

(LANG) Language Feature

Press this side button to toggle between the three languages - English, French and Spanish.

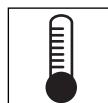

Degrees F/C Feature

Press this side button to toggle the temperature units between Fahrenheit and Celsius.

Display Contrast Adjustment

Press and hold the light button then push the hour button to increase the contrast or the minute button to decrease the contrast.

Using the Remote Control

NOTE: To activate the remote control functions, pull out the plastic pull tab protruding from the remote control housing.

This remote control is equipped with a proximity lighting feature. When moving a hand within close proximity to the remote control, the LED lights turn on for 3 seconds. Upon successful activation of a remote control button, the LED lights will blink rapidly.

Proximity Disable Feature

The remote control will turn off the proximity lighting feature if the proximity lighting is turned on 10 consecutive times without activation of a button. To re-enable the proximity lighting, simply press a button. This function conserves battery life.

To Control the Opener Lights

With 315MHz **SAFETY SIGNAL™** remote controls, a remote push button can be programmed to operate the opener lights without opening the door.

1. *With the door closed*, press and hold the remote button that you want to control the light.
2. Press and hold the Light button on the multi-function control panel.
3. Press and hold the Lock button on the multi-function control panel.
4. After the opener lights flash, release all buttons.

Test by pressing the remote push button. The opener lights should turn on or off but the door should not move.

Troubleshooting

PROBLEM	SOLUTION
Reduced proximity sensing (does not activate by touching top of remote control)	Check if proximity lighting is disabled by pressing a button.
	The Proximity Sensor may be oversensitized. Sit remote control undisturbed for 60 seconds on a non-metallic surface. This allows the sensor to recalibrate itself.
	Replace 3V2450 battery with same type 3V2450 coin cell.
Dim LED lights	Replace two 3V2016 batteries with same type 3V2016 coin cells.
No rapid LED blinking after pressing a button	Replace two 3V2016 batteries with same type 3V2016 coin cells.

The Remote Control Battery

WARNING

To prevent possible **SERIOUS INJURY** or **DEATH**:

- NEVER allow small children near batteries.
- If battery is swallowed, immediately notify doctor.

To reduce risk of fire, explosion or chemical burn:

- Replace **ONLY** with 3V2016 or 3V2450 coin batteries.
- Do **NOT** recharge, disassemble, heat above 100°C (212°F) or incinerate.

The 3V2016 lithium batteries for the opener and LED lights (marked "LED and Opener Battery") should last 5 years. The 3V2450 lithium battery for the proximity lighting (marked "Proximity Battery") should last 1-2 years.

To replace the batteries, remove the two screws and open the remote control housing. Push the battery out of the holder for removal. Insert replacement batteries positive side up. Dispose of old batteries properly.

Replace the batteries with only 3V2016 or 3V2450 coin cell batteries.

CAUTION: Do not bend spring contact. If bent the proximity sensor will not work.

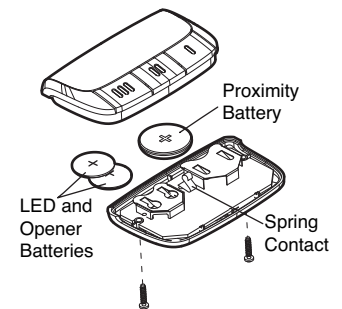

NOTICE: To comply with FCC and/or Industry Canada (IC) rules, adjustment or modifications of this receiver and/or transmitter are prohibited, except for changing the code setting or replacing the battery. **THERE ARE NO OTHER USER SERVICEABLE PARTS.**

Tested to Comply with FCC Standards FOR HOME OR OFFICE USE. Operation is subject to the following two conditions: (1) this device may not cause harmful interference, and (2) this device must accept any interference received, including interference that may cause undesired operation.

CARE OF YOUR OPENER

MAINTENANCE SCHEDULE

Once a Month

- Manually operate door. If it is unbalanced or binding, call a trained door systems technician.
- Check to be sure door opens & closes fully. Adjust limits and/or force if necessary (see *Adjustment Steps 1 and 2*).
- Repeat the safety reverse test. Make any necessary adjustments (see *Adjustment Step 3*).

Once a Year

- Oil door rollers, bearings and hinges. The opener does not require additional lubrication. Do not grease the door tracks.

HAVING A PROBLEM? (TROUBLESHOOTING)

1. The opener doesn't operate from either the Door Control or the remote control:

- Does the opener have electric power? Plug a lamp into the outlet. If it doesn't light, check the fuse box or the circuit breaker. (Some outlets are controlled by a wall switch.)
- Have you disabled all door locks? Review installation instruction warnings on page 7.
- Is there a build-up of ice or snow under the door? The door may be frozen to the ground. Remove any restriction.
- The garage door spring may be broken. Have it replaced (see page 3 for reference).

2. Opener operates from the remote, but not from the Door Control:

- Is the door control lit? If not, reverse the wires. If the opener runs, check for a faulty wire connection at the control console, a short under the staples, or a broken wire.
- Are the wiring connections correct? Review *Installation Step 5*, page 10.

3. The door operates from the Door Control, but not from the remote control:

- Is the door push bar flashing? If so, Lock mode is engaged. Make sure it is off by pressing the Lock button for two seconds.
- Program the opener to match the remote control code. (Refer to instructions on the motor unit panel.) Repeat with all Remote.

4. The remote control has short range:

- Change the location of the remote control in your car.
- Check to be sure the antenna on the side or back panel of motor unit extends fully downward.
- Some installations may have shorter range due to a metal door, foil backed insulation, or metal garage siding.

5. The garage door opens and closes by itself:

- Be sure that all remote control push buttons are off.
- Remove the bell wire from the door control terminals and operate from the remote only. If this solves the problem, the door control is faulty (replace), or there is an intermittent short on the wire between the control console and the motor unit.
- Clear memory and re-program all remote controls.

6. The door doesn't open completely:

- Check power door lock.
- Is something obstructing the door? Is it out of balance, or are the springs broken? Remove the obstruction or repair the door.

7. The door opens but won't close:

- Check cable tension monitor (see *Installation Step 4*).
- If the opener lights blink, check the safety reversing sensor. See *Installation Step 9*.
- If the opener lights don't blink and it is a new installation. See *Adjustment Step 2*. For an existing installation, see below.

Repeat the safety reverse test after the adjustment is complete.

8. The door reverses for no apparent reason and opener lights don't blink:

- Check cable tension monitor (see installation step 4).
- Is something obstructing the door? Pull the emergency release handle. Operate the door manually. If it is unbalanced or binding, call a trained door systems technician.
- Clear any ice or snow from the garage floor area where the door closes.
- Review *Adjustment Step 2*.

Repeat safety reverse test after adjustments.

Having a Problem? (Continued)

9. The door reverses for no apparent reason and opener lights blink for 5 seconds after reversing:

- Check the safety reversing sensor. Remove any obstruction or align the receiving eye. See *Installation Step 9*.

10. The opener strains to operate door:

- The door may be out of balance or the springs may be broken. **Close the door** and use the emergency release handle to disconnect the door. Open and close the door manually. A properly balanced door will stay in any point of travel while being supported entirely by its springs. If it does not, disconnect the opener and call a trained door systems technician.

11. The opener motor hums briefly, then won't work:

- The garage door springs may be broken. See above.
- If the problem occurs on the first operation of the opener, door may be locked. Disable the power door lock.

12. The opener won't operate due to power failure:

- Manually open the power door lock.
- Use the emergency release handle to disconnect the door. The door can be opened and closed manually. When power is restored, pull manual release a second time.
- If a Standby Power Unit is connected, the opener should be able to operate up to 20 times without power.

13. Door loses limits.

- Collar not tightened securely. Tighten collar (see *Assembly Steps 1 and 2*) and reprogram limits (see *Adjustment Step 1*).

14. The operator moves when the door is in operation:

- Some minor movement is normal for this product. If it is excessive the collar will wear prematurely.
- Check to make sure the torsion bar is not moving left/right excessively.
- Check to make sure the torsion bar is not visibly moving up and down as it rotates.
- Check that the operator is mounted at a right angle to the jackshaft. If not, move the position of the mounting bracket.

15. Power lock makes noise when operating.

- Call dealer for replacement power lock.

Smart Control Panel™ Messages

The following messages are contained within the Smart Control Panel™ and may appear during the operations of the unit:

Message

SAFETY SENSORS
CHECK ALIGNMENT,
BLOCKAGE OR
MISWIRING. SEE
OWNER'S MANUAL.

- **Meaning:** This message will appear if the Safety Reversing Sensors are out of alignment, if they are blocked or if the wiring is disconnected. To clear message from Smart Control Panel™ do the following:

- Check to see that area is clear between the Safety Reversing Sensors.
- Check to see that the Safety Reversing Sensors are not misaligned.
 - Realign receiving eye sensor, clean lens and secure brackets.
 - Verify door track is firmly secured to wall and does not move.
- Check to see that the Safety Reversing Sensors' wires are connected to the motor unit.
- If message has not cleared after the above checks, refer to message #2.

Message

SAFETY SENSORS
MALFUNCTION.
CHECK MISWIRING.
SEE OWNER'S
MANUAL.

- **Meaning:** This message will appear if the Safety Reversing Sensors are miswired. To clear the message, do the following:

- Inspect the safety sensor wires for a short (staple in wire), correct wiring polarity (black/white wires reversed), replace/attach as needed.
- Disconnect all wires from back of motor unit.
- Remove safety sensors from brackets and shorten sensor wires to 1-2 ft. (30-60 cm) from back of each sensor.
- Reattach sending eye to motor unit using shortened wires. If sending eye indicator light glows steadily, attach the receiving eye.
- Align sensors, if the indicator lights glow replace the wires for the sensors. If the sensor indicator lights do not light, replace the safety sensors.

Message

LEARN REMOTE
CONTROL. PRESS
LEARN BUTTON TO
CONFIRM.

- **Meaning:** This message will appear when the Prog <LEARN> button has been pressed on the Smart Control Panel™. Pressing the Prog <LEARN> button again will allow the user to program an additional remote control to the opener.

Message

LEARN MODE.
PRESS REMOTE
CONTROL BUTTON
TO PROGRAM
REMOTE.

- **Meaning:** This message will appear when the Prog <learn> button has been pressed a second time on the Smart Control Panel™ or anytime on the opener. The opener is ready to program another remote control by simply pressing the remote control button. Once the opener has 'LEARNED' the remote control, the worklight will blink one time.

Message

LOCK MODE.
REMOTE CONTROL
LOCKED OUT.
PRESS LOCK
BUTTON TO ENABLE
REMOTE.

- **Meaning:** This message will appear when the 'Lock' button has been pressed and held for more than one second. This feature will disable the opener from receiving remote control signals. To exit 'LOCK' mode, press and hold the button for more than one second.

Message

ENGLISH, FRANÇAIS
AND ESPAÑOL.

- **Meaning:** This message will appear when the 'Language' button has been pressed. Pressing the button will toggle to the next language.

Message

MOTION SENSING
ON, MOTION
SENSING OFF.

- **Meaning:** This message will appear when the 'MOTION SENSING' button is pressed. The Motion Detector will toggle on or off with each press of the button.

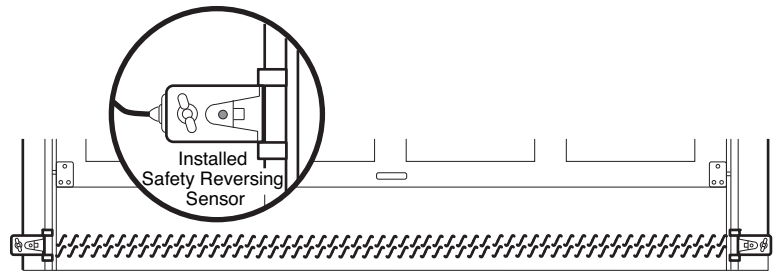
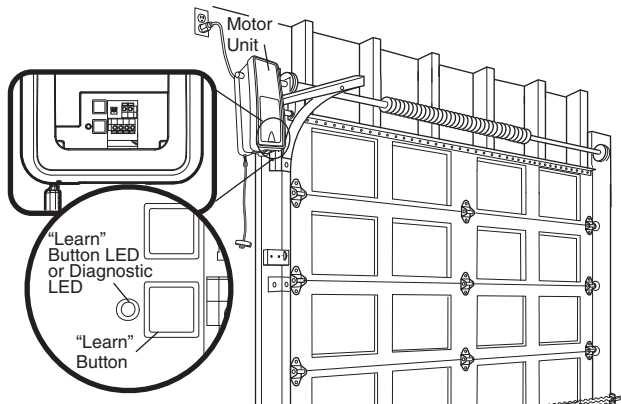

Your garage door opener is programmed with self-diagnostic capabilities. The "Learn" button/diagnostic LED will flash a number of times then pause signifying it has found a potential issue. Consult Diagnostic Chart below.

Diagnostic Chart

1 FLASH

Safety reversing sensors wire open (broken or disconnected).

OR

2 FLASHES

Safety reversing sensors wire shorted or black/white wire reversed.

3 FLASHES

Door control or wire shorted.

4 FLASHES

Safety reversing sensors slightly misaligned (dim or flashing LED).

5 FLASHES

Motor overheated or possible RPM sensor failure. Unplug to reset.

9 FLASHES

Cable tension monitor reversal.

● **Symptom: One or both of the Indicator lights on the safety reversing sensors do not glow steady.**

- Inspect sensor wires for a short (staple in wire), correct wiring polarity (black/white wires reversed), broken or disconnected wires, replace/attach as needed.
- Disconnect all wires from back of motor unit.
- Remove sensors from brackets and shorten sensor wires to 1-2 ft (30-60 cm) from back each of sensor.
- Reattach sending eye to motor unit using shortened wires. If sending eye indicator light glows steadily, attach the receiving eye.
- Align sensors, if the indicator lights glow replace the wires for the sensors. If the sensor indicator lights do not light, replace the safety reversing sensors.

● **Symptom: LED is not lit on door control.**

- Inspect door control/wires for a short (staple in wire), replace as needed.
- Disconnect wires at door control, touch wires together. If motor unit activates, replace door control.
- If motor unit does not activate, disconnect door control wires from motor unit. Momentarily short across red and white terminals with jumper wire. If motor unit activates, replace door control wires.

● **Symptom: Sending indicator light glows steadily, receiving indicator light is dim or flashing.**

- Realign receiving eye sensor, clean lens and secure brackets.
- Verify door track is firmly secured to wall and does not move.

● **Symptom: Motor has overheated; the motor unit does not operate = Motor unit hums briefly; RPM Sensor = Short travel 6-8" (15-20 cm).**

- Unplug unit to reset. Try to operate motor unit, check diagnostic code.
- If it is still flashing 5 times and motor unit moves 6-8" (15-20 cm), replace RPM sensor.
- If motor unit doesn't operate, motor unit is overheated. Wait 30 minutes and retry. If motor unit still will not operate replace logic board.

● **Symptom: Door reverses while closing.**

- Check for possible door obstructions and remove.
- Check that the cable tension monitor is properly connected to the operator.
- Replace the cable tension monitor.

PROGRAMMING

NOTICE: If this **SAFETY SIGNAL™** garage door opener is operated with a non-rolling code transmitter, the technical measure in the receiver of the garage door opener, which provides security against code-theft devices, will be circumvented. The owner of the copyright in the garage door opener does not authorize the purchaser or supplier of the non-rolling code transmitter to circumvent that technical measure.

Your garage door opener has already been programmed at the factory to operate with your hand-held remote control. The door will open and close when you press the large push button.

Below are instructions for programming your opener to operate with additional **SAFETY SIGNAL™** remote controls.

To Add or Reprogram a Hand-held Remote Control

USING THE "LEARN" BUTTON

USING THE SMART CONTROL PANEL™

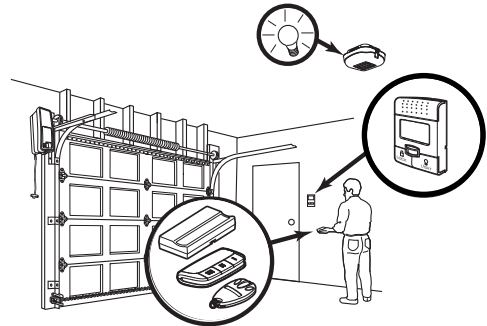
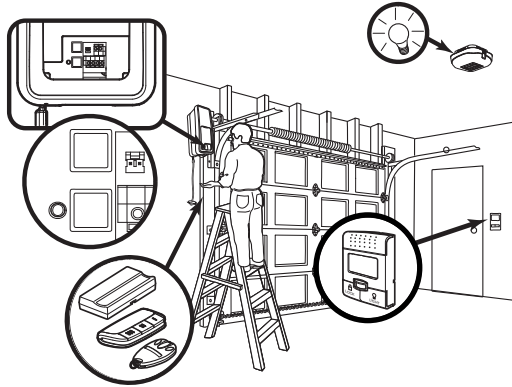

1. Press and release the purple "learn" button on the motor unit. The learn indicator light will glow steadily for 30 seconds.

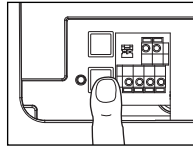

1. Press the Prog <Learn> button on the Smart Control Panel™.

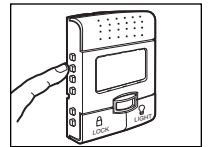

2. Within 30 seconds, press and hold the button on the hand-held remote* that you wish to operate your garage door.

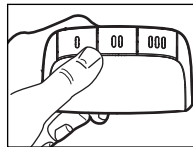

2. Press the Prog <Learn> button again to confirm Learn Mode.

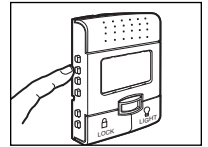

3. Release the button when the motor unit lights blink. It has learned the code. If light bulbs are not installed, two clicks will be heard.

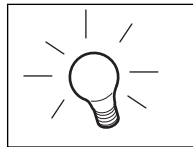

3. Press the button on the hand-held remote that you wish to operate your garage door.

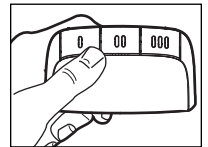

4. When the motor unit lights blink, it has learned the code. If light bulbs are not installed, two clicks will be heard.



To Erase All Codes From Motor Unit Memory

To deactivate any unwanted remote, first erase all codes:

Press and hold the "learn" button on motor unit until the learn indicator light goes out (approximately 6-9 seconds). All previous codes are now erased. Reprogram each remote or keyless entry you wish to use.

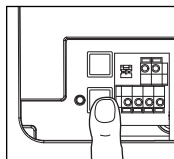

*3-Button Remote

If provided with your garage door opener, the large button is factory programmed to operate it. Additional buttons on any **SAFETY SIGNAL™** 3-Button remote or mini-remote can be programmed to operate other Safety Signal™ garage door openers.

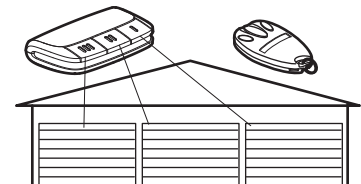

To Add, Reprogram or Change a Keyless Entry PIN

NOTE: Your new Keyless Entry must be programmed to operate your garage door opener.

USING THE "LEARN" BUTTON

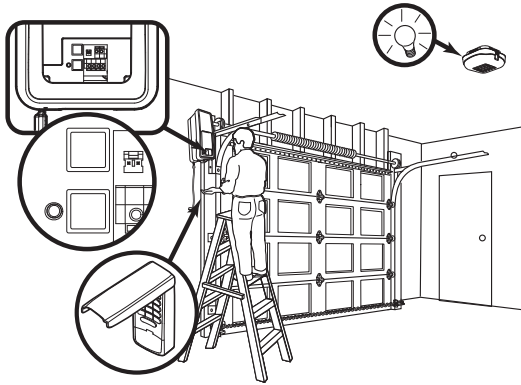

1. Press and release the purple "learn" button on motor unit. The learn indicator light will glow steadily for 30 seconds.
2. Within 30 seconds, enter a four digit personal identification number (PIN) of your choice on the keypad. Then press and hold the ENTER button.
3. Release the button when the motor unit lights blink. It has learned the code. If light bulbs are not installed, two clicks will be heard.

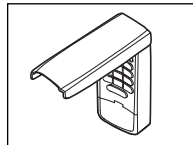
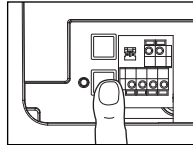

To change an existing, known PIN

If the existing PIN is known, it may be changed by one person without using a ladder.

1. Press the four buttons for the present PIN, then press and hold the # button.

The opener light will blink twice. Release the # button.

2. Press the new 4-digit PIN you have chosen, then press Enter.

The motor unit lights will blink once when the PIN has been learned.

Test by pressing the new PIN, then press Enter. The door should move.

To set a temporary PIN

You may authorize access by visitors or service people with a temporary 4-digit PIN. After a programmed number of hours or number of accesses, this temporary PIN expires and will no longer open the door. It can be used to close the door even after it has expired. To set a temporary PIN:

1. Press the four buttons for your personal entry PIN (not the last temporary PIN), then press and hold the * button.

The opener light will blink three times. Release the button.

2. Press the temporary 4-digit PIN you have chosen, then press Enter.

The opener light will blink four times.

USING THE SMART CONTROL PANEL™

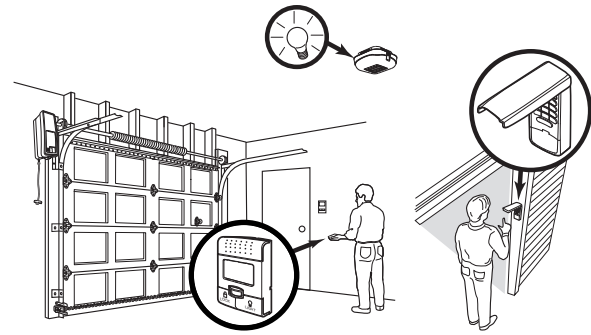

NOTE: This method requires two people if the Keyless Entry is already mounted outside the garage.

1. Press the Prog <Learn> button on the Smart Control Panel™.

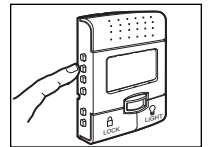

2. Press the Prog <Learn> button again to confirm Learn Mode.

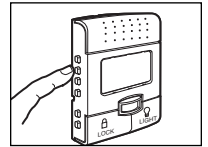

3. Enter a four digit personal identification number (PIN) of your choice on the keypad. Then press enter.

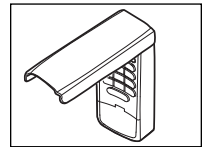

4. When the motor unit lights blink, it has learned the code. If light bulbs are not installed, two clicks will be heard.

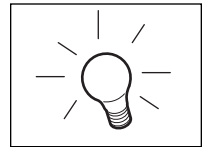

3. To set the number of **hours** this temporary PIN will work, press the number of hours (up to 255), then press *.

OR

3. To set the number of **times** this temporary PIN will open door, press the number of times (up to 255), then press #.

The opener light will blink once when the temporary PIN has been learned.

Test by pressing the four buttons for the temporary PIN, then press Enter. The door should move. If the temporary PIN was set to a certain number of openings, remember that the test has used up one opening. To clear the temporary password, repeat steps 1-3, setting the number of hours or times to 0 in step 3.

One Button Close: Opener can be closed by pressing only the ENTER button if the one button close feature has been activated. This feature has been activated at the factory. To activate or deactivate this feature press and hold buttons 1 and 9 for 10 seconds. The keypad will blink twice when the one button close is active. The keypad will blink four times when one button close is deactivated.

Reprogramming Light or Additional Light

Your garage door opener remote light has already been programmed at the factory to operate with your opener. Any additional or replacement remote lights will need to be programmed.

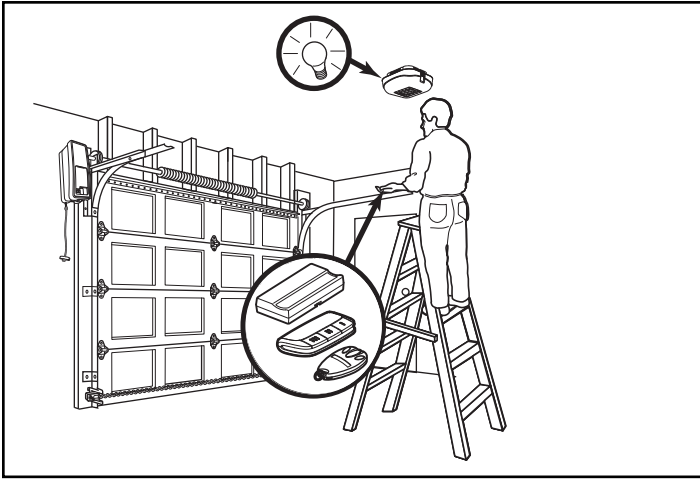

1. Press the “learn button” on light until LED comes ON.

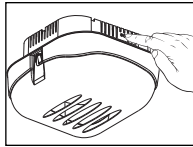

2. Activate the garage door using the hand-held remote, wall control or keyless entry.

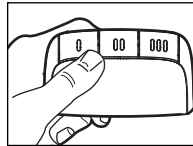

3. It has learned the code and the light turns on.

REPAIR PARTS

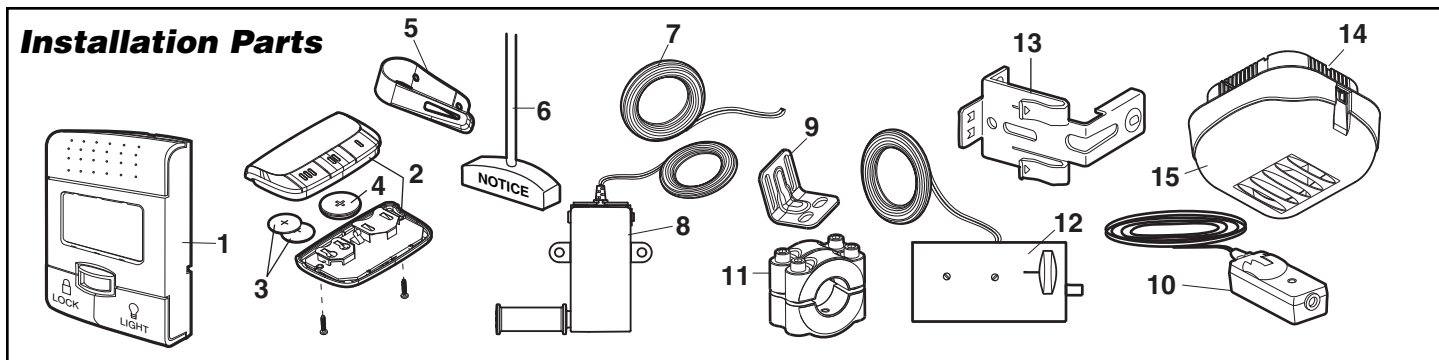

KEY NO.	PART NO.	DESCRIPTION	KEY NO.	PART NO.	DESCRIPTION
1	41A6319-2	Smart Control Panel™	11	41A6388	Collar with set screws (2)
2	373PG	3-Button remote control	12	41A6102	Power door lock
3	10A19	3V2016 lithium battery: led and opener	13	41A5266-1	Safety sensor brackets (2)
4	10A33	3V2450 lithium battery: proximity switch	14	380LM	Remote Light (Opener Light)
5	29C151	Remote control visor clip	15	41D96-1	Light lens for light
6	41A4582	Emergency release rope & handle assembly			NOT SHOWN
7	41B4494-1	2-Conductor bell wire - white & white/red		101D173	Push bar for door control
8	41A6104	Cable tension monitor		41A6288	Hardware bag for light
9	41C0902	Mounting bracket		41A6298	Installation hardware bag (includes hardware listed on page 5)
10	41A5034	Safety sensor kit (receiving and sending eyes) with 3' (.9 m) 2-conductor bell wire attached		114A3521	Owner's manual

Motor Unit Assembly Parts

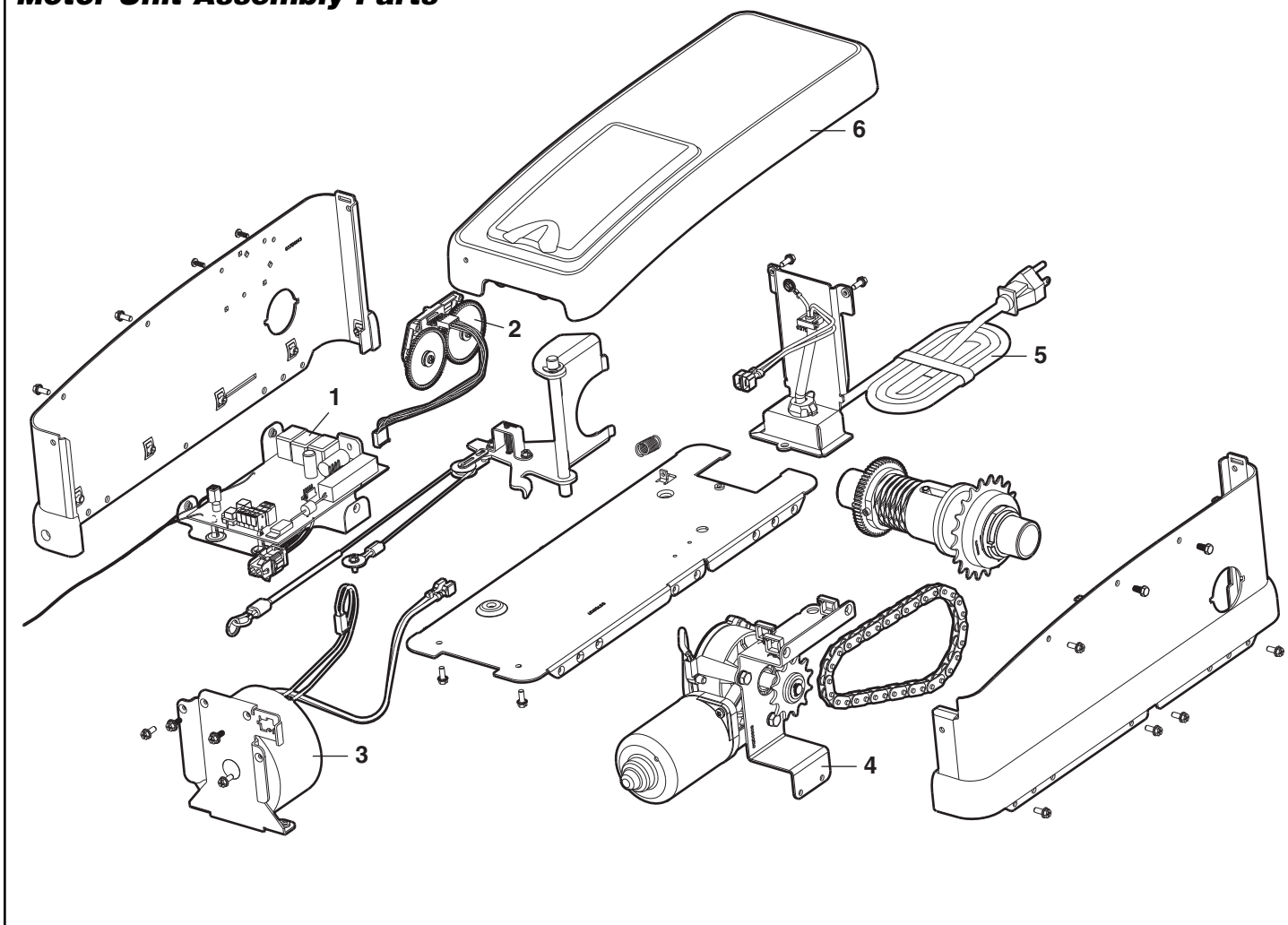

KEY NO.	PART NO.	DESCRIPTION	KEY NO.	PART NO.	DESCRIPTION
1	41DJ001	Logic board complete with plate	4	41A6095	Motor with bracket
2	41A6408	Absolute Encoder System	5	41B122	Power cord
3	41C168	Transformer	6	41A6348-5	Cover

ACCESSORIES

41A5281

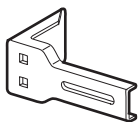

Extension Brackets:

(Optional) For safety reversing sensor installation onto the wall or floor.

377LG

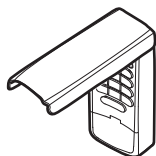

Keyless Entry with Security+®:

Enables homeowner to operate garage door opener from outside by entering a password on a specially designed keyboard. Also can add a temporary password for visitors or service persons. This temporary password can be limited to a programmable number of hours or entries.

902LM/903LM

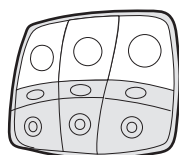

2 & 3 Door Multi-Function Wall Control:

Ideal for homes with up to three garage doors. Combine up to three controls into one wall control panel for a neat compact appearance. Enhanced functions include Lock Feature to lock out outside radio signals while you are away from home and turn opener lights on or off from the control panel.

395LM

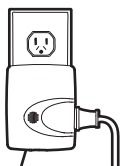

Remote Light Control:

Enables homeowner to turn on a lamp, television or other appliance from their car with their garage door opener remote or from anywhere in their home with an additional LiftMaster Safety Signal™ remote.

380LM

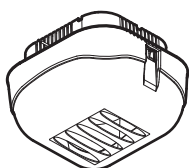

Remote Light:

Enables homeowner to turn on a work light from their car with their garage door opener remote or from anywhere in their home with an additional LiftMaster Safety Signal™ remote.

975LM



Laser Park Assist:

Laser enables homeowners to precisely park vehicles in the garage.

373W

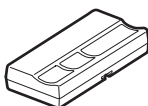

Designer Burled Walnut 3-Button Remote Control with Security+®:

Includes visor clip.

373RGD



3-Button Safety Signal™ Remote Control:

Includes visor clip.

370LM



3-Button Mini-Remote Control with Security+®:

With key ring.

378LM

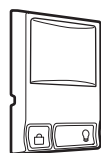

Wireless Door Control:

Push bar, light feature and auxiliary button. Includes battery.

915LM



Garage Door Monitor:

Security for the largest door of your home!

Tells you if your garage door is open or closed. Monitors up to 4 garage doors by adding additional sensor modules.

916LM



Garage Door Monitor Sensor:

Additional accessory sensor for homes with multiple garage doors.

475RGD

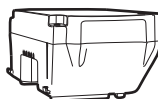

Standby Power Unit:

Provides backup power to the model 3800RGD garage door opener.

373PG



3-Button Security+® Remote Control:

Includes visor clip.

480LM

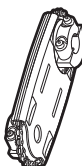

Alternate Mounting Kit:

This kit allows model 3800RGD to be mounted below the torsion bar in the case where the torsion bar is not round or the normal mounting area is obstructed.

RAYNOR® GARAGE DOORS SERVICE IS ON CALL

OUR LARGE SERVICE ORGANIZATION
SPANS AMERICA

INSTALLATION AND SERVICE INFORMATION IS AS
NEAR AS YOUR TELEPHONE FIVE DAYS A WEEK.
SIMPLY DIAL OUR TOLL FREE NUMBER:
1-800-472-9667

For professional installation, parts and service,
contact your local RAYNOR® GARAGE DOORS
distributor. Look for him in the Yellow Pages, or visit our
Dealer Locator on our Website www.Raynor.com.

HOW TO ORDER REPAIR PARTS

Selling prices will be furnished on request or parts will
be shipped at prevailing prices and you will be billed
accordingly.

WHEN ORDERING REPAIR PARTS, ALWAYS GIVE
THE FOLLOWING INFORMATION:

- PART NUMBER
- PART NAME
- MODEL NUMBER

ADDRESS ORDERS TO:

RAYNOR® GARAGE DOORS
Technical Support Group
6050 S. Country Club Road
Tucson, Arizona 85706

SERVICE INFORMATION TOLL FREE NUMBER:

1-800-528-9131

RAYNOR® GARAGE DOOR OPENER FIVE-YEAR LIMITED WARRANTY LIFETIME MOTOR LIMITED WARRANTY

RAYNOR® ("Seller") warrants to the first retail purchaser of this product, for the residence in which this product is originally installed, that it is free from defect in materials and/or workmanship for a period of five years from the date of purchase [and that the motor is free from defect in materials and/or workmanship for a period of lifetime from the date of purchase]. The proper operation of this product is dependent on your compliance with the instructions regarding installation, operation, maintenance and testing. Failure to comply strictly with those instructions will void this limited warranty in its entirety.

If, during the limited warranty period, this product appears to contain a defect covered by this limited warranty, call 1-800-528-9131, toll free, before dismantling this product. Then send this product, pre-paid and insured, to our service center for warranty repair. You will be advised of shipping instructions when you call. Please include a brief description of the problem and a dated proof-of-purchase receipt with any product returned for warranty repair. Products returned to Seller for warranty repair, which upon receipt by Seller are confirmed to be defective and covered by this limited warranty, will be repaired or replaced (at Seller's sole option) at no cost to you and returned pre-paid. Defective parts will be repaired or replaced with new or factory-rebuilt parts at Seller's sole option.

ALL IMPLIED WARRANTIES FOR THE PRODUCT, INCLUDING BUT NOT LIMITED TO ANY IMPLIED WARRANTIES OF MERCHANTABILITY AND FITNESS FOR A PARTICULAR PURPOSE, ARE LIMITED IN DURATION TO THE FIVE YEAR LIMITED WARRANTY PERIOD SET FORTH ABOVE [EXCEPT THE IMPLIED WARRANTIES WITH RESPECT TO THE MOTOR, WHICH ARE LIMITED IN DURATION TO THE LIFETIME LIMITED WARRANTY PERIOD FOR THE MOTOR], AND NO IMPLIED WARRANTIES WILL EXIST OR APPLY AFTER SUCH PERIOD. Some States do not allow limitations on how long an implied warranty lasts, so the above limitation may not apply to you. THIS LIMITED WARRANTY DOES NOT COVER NON-DEFECT DAMAGE, DAMAGE CAUSED BY IMPROPER INSTALLATION, OPERATION OR CARE (INCLUDING, BUT NOT LIMITED TO ABUSE, MISUSE, FAILURE TO PROVIDE REASONABLE AND NECESSARY MAINTENANCE, UNAUTHORIZED REPAIRS OR ANY ALTERATIONS TO THIS PRODUCT), LABOR CHARGES FOR REINSTALLING A REPAIRED OR REPLACED UNIT, REPLACEMENT OF BATTERIES AND LIGHT BULBS OR UNITS INSTALLED FOR NON-RESIDENTIAL USE.

THIS LIMITED WARRANTY DOES NOT COVER ANY PROBLEMS WITH, OR RELATING TO, THE GARAGE DOOR OR GARAGE DOOR HARDWARE, INCLUDING BUT NOT LIMITED TO THE DOOR SPRINGS, DOOR ROLLERS, DOOR ALIGNMENT OR HINGES. THIS LIMITED WARRANTY ALSO DOES NOT COVER ANY PROBLEMS CAUSED BY INTERFERENCE. ANY SERVICE CALL THAT DETERMINES THE PROBLEM HAS BEEN CAUSED BY ANY OF THESE ITEMS COULD RESULT IN A FEE TO YOU.

UNDER NO CIRCUMSTANCES SHALL SELLER BE LIABLE FOR CONSEQUENTIAL, INCIDENTAL OR SPECIAL DAMAGES ARISING IN CONNECTION WITH USE, OR INABILITY TO USE, THIS PRODUCT. IN NO EVENT SHALL SELLER'S LIABILITY FOR BREACH OF WARRANTY, BREACH OF CONTRACT, NEGLIGENCE OR STRICT LIABILITY EXCEED THE COST OF THE PRODUCT COVERED HEREBY. NO PERSON IS AUTHORIZED TO ASSUME FOR US ANY OTHER LIABILITY IN CONNECTION WITH THE SALE OF THIS PRODUCT.

Some states do not allow the exclusion or limitation of consequential, incidental or special damages, so the above limitation or exclusion may not apply to you. This limited warranty gives you specific legal rights, and you may also have other rights which vary from state to state.