

# Instruction Manual

Model RAM-30 UL

For Class I Vehicular Gate Operators



REV 5/02



## Table of Contents

Important Safety Requirements & Instructions .....	2,3
Mechanical Specifications .....	3,4
Installation Specifications	
Pad Construction .....	5
Recommended Wire Gauge / Voltage Drop Chart .....	5
Installing a Swing Gate Operator .....	5,6
Gate Travel Adjustment .....	7
Pushbutton Controls .....	7
Electrical Connection .....	8
Intelligate PCB Motor Controller Specification	
Introduction .....	9
DIP Switch Configurations .....	9,10
Terminal Strip Connections .....	10
Control Input Description .....	10
Safety Input Description .....	10
Outputs .....	10
Other Connections .....	10
Wiring Diagram .....	11
Sensor Installation .....	12
Master - Slave Installation .....	13
RAM-30 Bill of Materials .....	14
RAM-30 Parts Diagram .....	15
Glossary .....	16

## Important Safety Requirements & Instructions

### **WARNING - To reduce the risk of injury or death:**

1. **READ AND FOLLOW ALL INSTRUCTIONS!**
2. Never let children operate or play with gate controls. Keep the remote control away from children.
3. Always keep people and objects away from the gate. **NO ONE SHOULD CROSS THE PATH OF THE MOVING GATE.**
4. Test the Vehicular Gate Operator monthly. The gate **MUST** reverse on contact with a rigid object or stop when an object activates the non-contact sensors. After adjusting the limit of travel, retest the Vehicular Gate Operator. Failure to adjust and retest the Vehicular Gate Operator properly can increase the risk of injury or death.
5. Use the Emergency Release only when power switch or circuit breaker has been turned off. Using the Emergency Release during a power failure can be a hazard if power is abruptly restored.
6. **KEEP GATES PROPERLY MAINTAINED.** Read the Owner's Manual. Have a qualified service person make repairs to gate hardware.
7. The entrance is for vehicles only. Pedestrians must use separate entrance.
8. **SAVE THESE INSTRUCTIONS.**

**NOTE: Always consult and follow all local building and electrical codes prior to installation.**

Ramset Gate Operators should not be installed without non-contact sensing devices such as non-contact sensors, photo electric sensors or the equivalent.

### **WARNING**

A non-contact sensor (photoelectric sensor or equivalent) and a contact sensor (edge device or equivalent) is required on each individual installation to comply with UL325.

### **Reversing Sensors (Loop Detectors)**

Reversing Sensors should be used to prevent gate from closing when a vehicle is in the gate area.

**Installation should be done by a qualified installer only.**

Prior to Installation, the following must be observed: (per UL 325 51.8.4)

- a) Install the vehicular gate operator only when:
  - 1) The Vehicular Gate Operator is appropriate for the construction of the gate and the usage Class of the gate,
  - 2) All openings of a horizontal slide gate are guarded or screened from the bottom of the gate to a minimum of 4 feet (1.2 m) above the ground to prevent a 2-1/4 inch (57.15 mm) diameter sphere from passing through the openings anywhere in the gate, and in that portion of the adjacent fence that the gate covers in the open position.
  - 3) All exposed pinch points are eliminated or guarded, and
  - 4) Guarding is supplied for exposed rollers.
- b) The Vehicular Gate Operator is intended for installation only on gates used for vehicles. Pedestrians must be supplied with a separate access opening.
- c) The gate must be installed in a location so that enough clearance is supplied between the gate and adjacent structures when opening and closing to reduce the risk of entrapment. Swinging gates shall not open into public access areas.
- d) The gate must be properly installed and work freely in both directions prior to the installation of the Vehicular Gate Operator. Do not over-tighten the operator clutch to compensate for a damaged gate.
- e) Controls must be far enough from the gate so that the user is prevented from coming in contact with the gate while

operating the controls. Controls intended to be used to reset a Vehicular Gate Operator after 2 sequential activations of the entrapment protection device or devices must be located in the line-of-sight of the gate. Outdoor or easily accessible controls shall have a security feature to prevent unauthorized use.

- f) All warning signs and placards must be installed where visible in the area of the gate.
- g) For Vehicular Gate Operators utilizing a non-contact sensor in accordance with 30A.1.1 Type B1 non-contact sensor (photo electric sensor or the equivalent)
  - 1) See instructions on the placement of non-contact sensors for each Type of application,
  - 2) Care shall be exercised to reduce the risk of nuisance tripping, such as when a vehicle, trips the sensor while the gate is still moving, and
  - 3) One or more non-contact sensors shall be located where the risk of entrapment or obstruction exists, such as the perimeter reachable by a moving gate or barrier.
- h) For a Vehicular Gate Operator utilizing a contact sensor in accordance with 30A.1.1
  - 1) One or more contact sensors shall be located at the leading edge, trailing edge, and postmounted both inside and outside of a vehicular horizontal slide gate.
  - 2) One or more contact sensors shall be located at the bottom edge of a vehicular vertical lift gate.
  - 3) One or more contact sensors shall be located at the pinch point of a vehicular vertical pivot gate.
  - 4) A hardwired contact sensor shall be located and its wiring arranged so that the communication between the sensor and the vehicular gate operator is not subjected to mechanical damage.
  - 5) A wireless contact sensor such as one that transmits radio frequency (RF) signals to the vehicular gate operator for entrapment protection functions shall be located where the transmission of the signals are not obstructed or impeded by building structures, natural landscaping or similar obstruction. A wireless contact sensor shall function under the intended end-use conditions.

### **MECHANICAL SPECIFICATIONS:**

Description	RAM-30
Power Input:	120 VAC
Electric Motor:	1/2 HP 120VAC, 5.2A, 100 RPM
Capacitor:	Aerovox 65µf, 240V, 50/60 hz protected S 10000 AFC
Cycles:	30 cycles per hour
ON/OFF Switch:	120VAC
Max. Gate capacity:	up to 13 feet
Max. Gate Weight:	400 lbs.
Gate Travel Speed:	approx. 14 seconds per 90°
Speed Reducer:	by Worm Gear Reducer, continuously lubricated in oil bath.
Chassis:	Rust-preventing Gold/Zinc coated 10ga metal
Gate Stops:	with Limit Switches
Cover:	high-impact resistant Polyethylene
Color:	Charcoal Gray
<b>Emergency Release:</b>	manual hand release
Shipping Weight:	75 lbs.
Type of Load:	Standard - Level
Application:	Residential
Overall Dimensions:	W=13", D=12-1/2", H=20"

Operators shown with covers removed

Figure 1

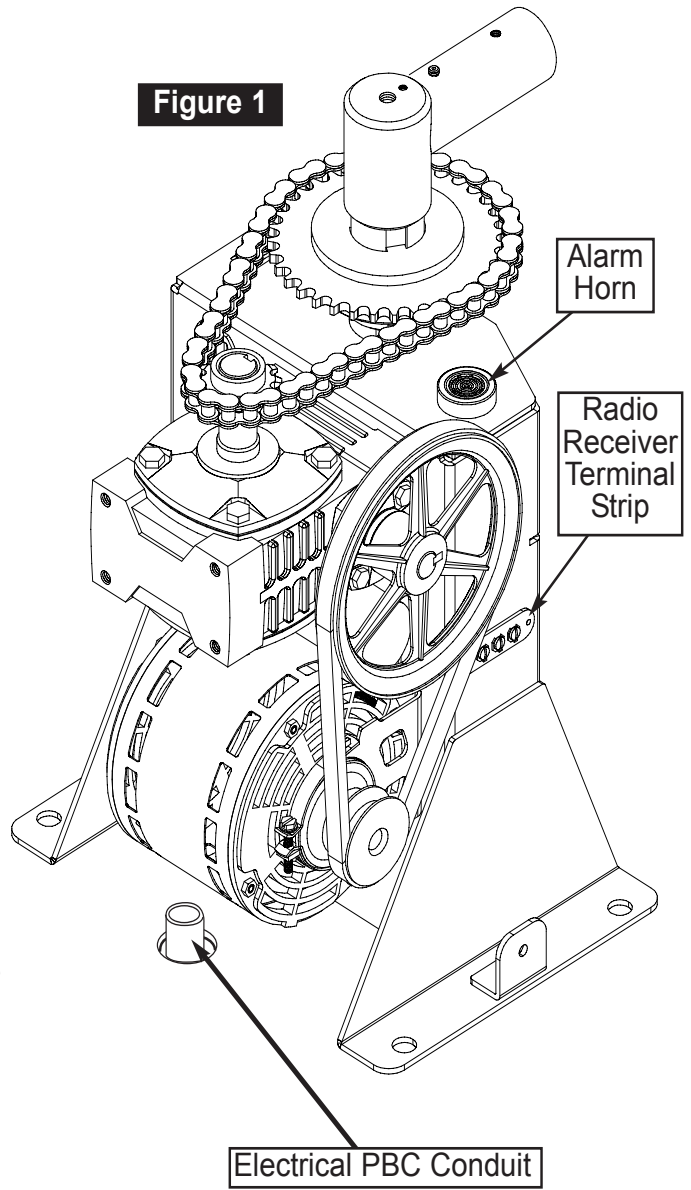
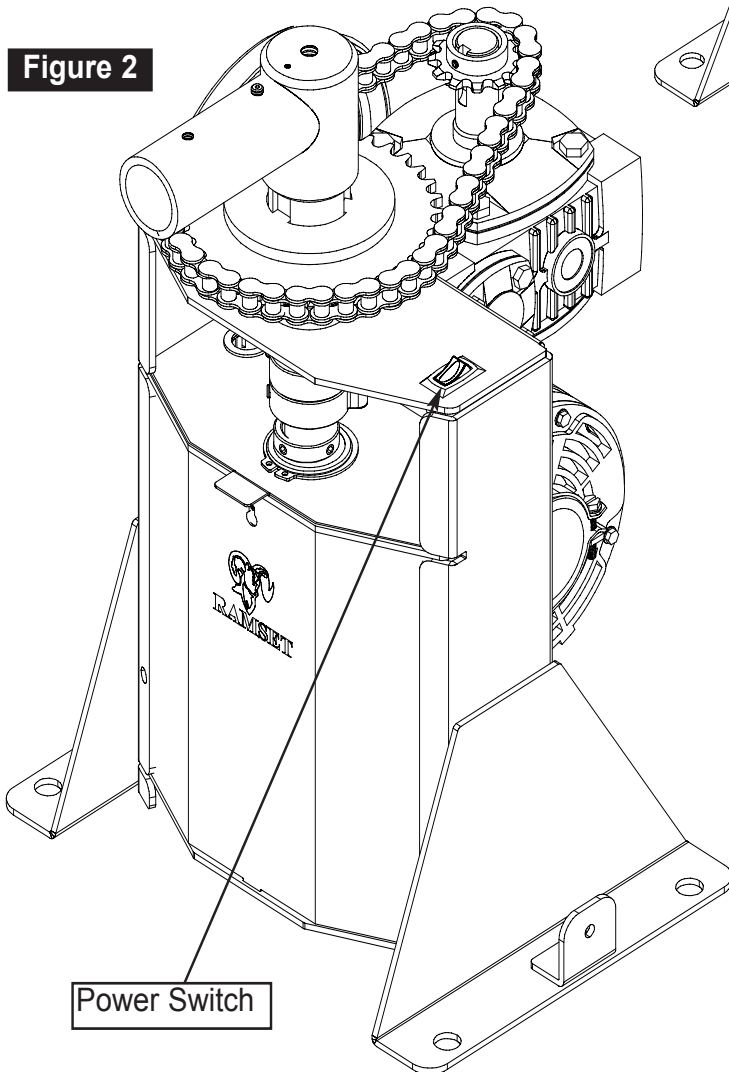

Figure 2



## Installation Specifications

### Pad Construction:

Dimensions given for pad are based on soil bearing shear of 2000 P.S.F. These figures may have to be adjusted depending on local soil condition.

1. Construct form for mounting pad according to dimensions shown in **Figure 3** and **4**.

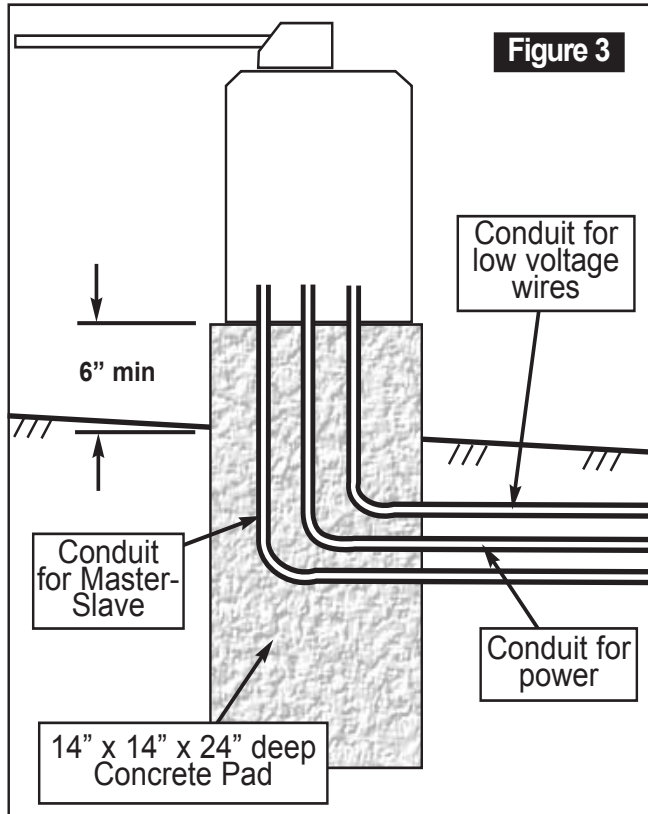

2. Locate mounting pad according to dimensions given in illustration.
3. Level top edge of form.
4. Set reinforcing bars and wire mesh.
5. Mix concrete; pour mixture into form. Tamp mixture. Level and finish surface after pouring is complete.
6. Allow pad to cure 48 hours, and remove forms.
7. Install Anchor Bolts: Mark centers and install four 1/2-13" UNC Red-head Anchor Bolts

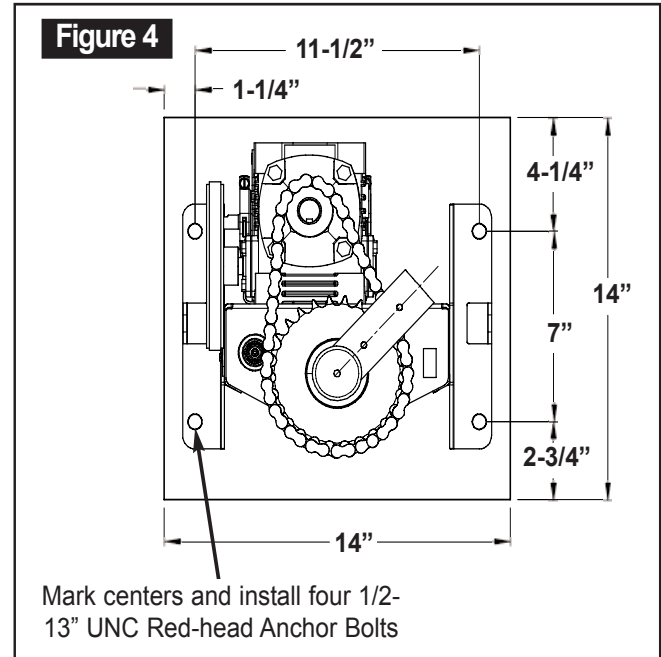

### Recommended Wire Gauge / Voltage Drop Chart

INPUT POWER	MOTOR HP	AMPERES		MAXIMUM CONDUIT DISTANCE IN FEET USING COPPER WIRE BY WIRE SIZE			
		RUN	START	14 GA	12 GA	10 GA	8 GA
120V Single Phase	1/2	4.7	5.0	up to 50'	50-100'	100-200'	200-300'

### Installing a Swing Gate Operator

#### I. Locating the Operator

1. Measure the length of the gate (L).  
If the length of the gate is over 12 ft., then divide the length by 4 (L/4).  
If the length of the gate is less than 12 ft., then divide the length by 3 (L/3).

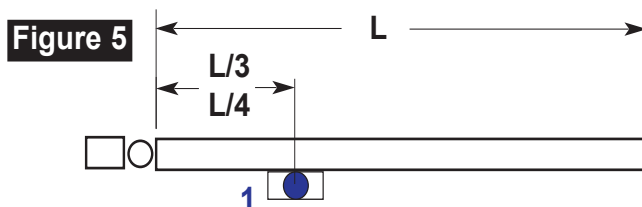

2. Now clamp the gate bracket near this location. (Do not weld the bracket until the installation is completed and thoroughly tested.)
3. When gate is fully closed, mark the point under the gate bracket where the arm is going to be attached (L/4 or L/3). (see blue dot 1, **Figure 5**)
4. Open gate to desired degree and mark the point under the gate bracket where the arm is going to be attached (L/4 or L/3). (see Blue dot 2, **Figure 6**)

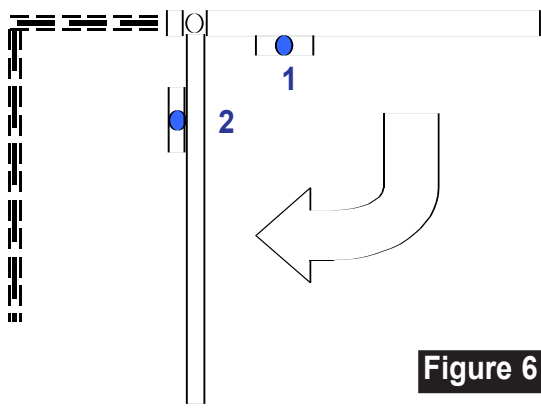

**Figure 6**

5. After marking the two spots, draw a line between the two marks and extend it past where the operator will be (see red line, **Figure 7**).

**Figure 7**

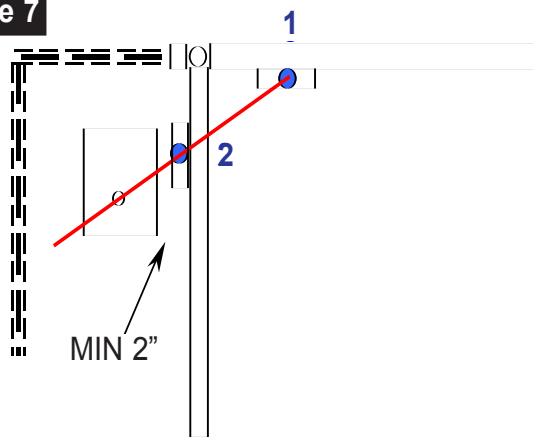

6. The center of the pivot shaft, on the operator, should be located on this line with at least a 2" gap between the cover of the operator and the gate when fully open.

## II. Determining the Length of the Arms

1. Now that the operator is in place, completely close the gate.
2. Get a string (green line) and tie one end to the gate bracket (see blue dot 1, **Figure 8**).
3. Tie the other end to the pivot shaft on the operator (see red dot 2, **Figure 8**).

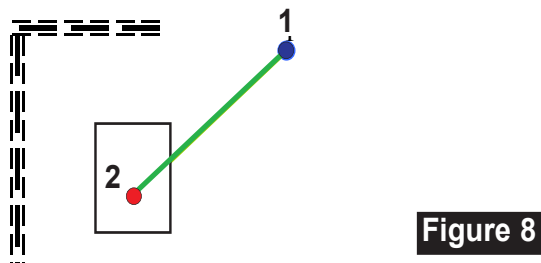

**Figure 8**

4. Slowly open the gate. While opening the gate, place a finger against the string (see point A, **Figure 9**) and hold the string taut and level until the gate is fully open.

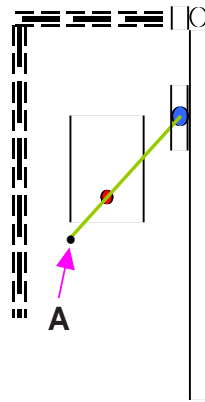

\* If the wall is too close to the operator to overlap the string, place point A as close to the wall as room allows and then proceed to step 6.

**Figure 9**

5. When the gate is fully open, move your finger until the string is overlapping the pivot shaft on the operator (see \*).
6. Your finger, Point A, represents the pivot/hinge bolt between the two arms.
7. Mark the string where your finger is, Point A.
8. The distance between point A and the pivot shaft on the operator is represented by 'S'.
9. The distance between point A and the bolt on the gate bracket is represented by 'L'.
10. Cut the arms to resemble **Figure 10**. Measurements 'S' & 'L' are NOT the exact lengths of the arms; the bracket and hardware will affect the actual lengths of the arms.

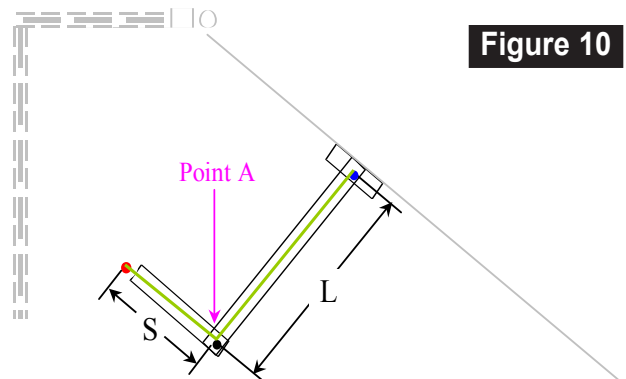

**Figure 10**



## GATE TRAVEL ADJUSTMENT

To adjust gate travel, loosen set screw(s) on Cam Slam(s) and rotate to required position (**Figure 11**).

LED must turn on to indicate fully open position or fully closed position when limit switch is activated by limit switch adjustment nut.

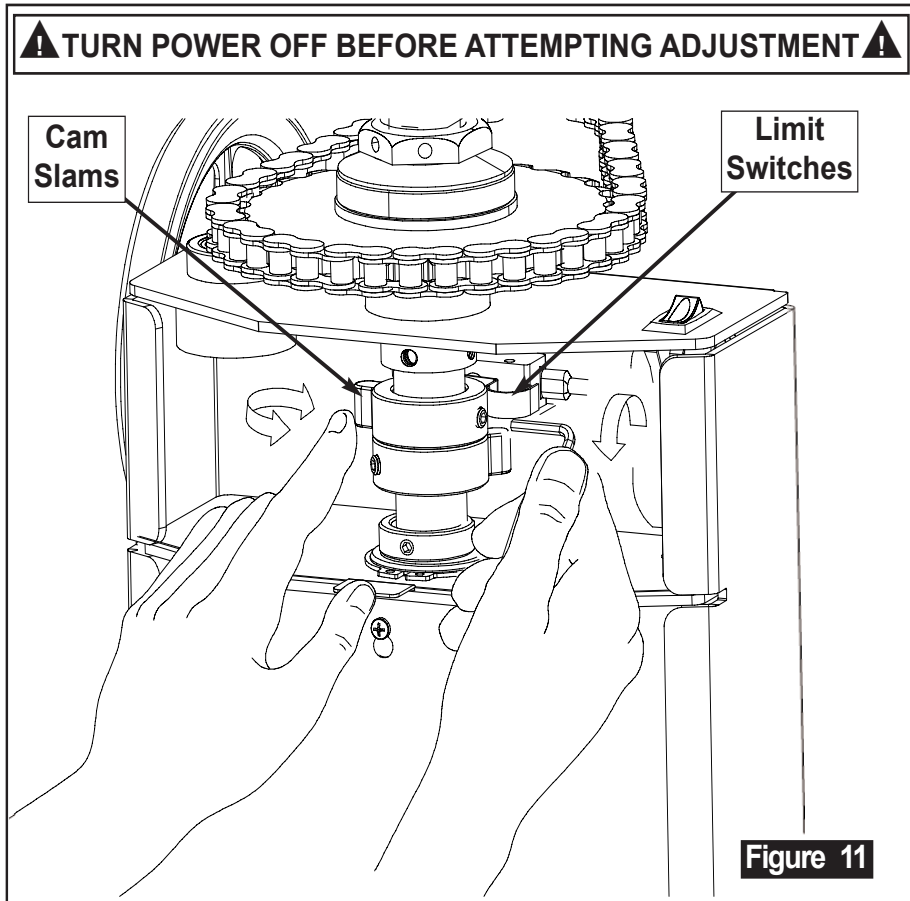

## PUSHBUTTON CONTROLS

Three pushbuttons are located under the dip switches for manual operation of the gate (see **Figure 12**). The open, stop, and close buttons can be utilized to set limit switches and verify proper system operation when installing or servicing an operator.

### Open

Pressing this button will cause the gate to open.

### Stop

Pressing this button will cause the gate to stop moving.

### Close

Pressing this button will cause the gate to close.

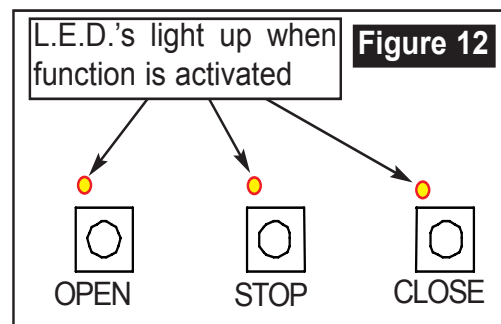

## ELECTRICAL CONNECTION

A 3 wire, 120VAC electrical circuit with a 15 amp independent circuit breaker is required for each operator. Ideally, the electrical conduits should exit the concrete under the operator. Low voltage control wires must be run in a separate conduit to the operator as shown.

**Intelligate<sup>®</sup> Control Board:** The Control Board is completely solid state. L.E.D. readouts show the status of the operator and control systems allowing for instant troubleshooting. The PCB circuitry plugs into an edge connector eliminating the need to disconnect any wires when replacing the board.

**⚠ WARNING**  
**ALWAYS TURN OFF POWER**  
**WHEN SERVICING OPERATOR!**

**⚠ CAUTION**  
**Check that gate is clear of people or obstructions**  
**BEFORE turning power ON to avoid injury.**

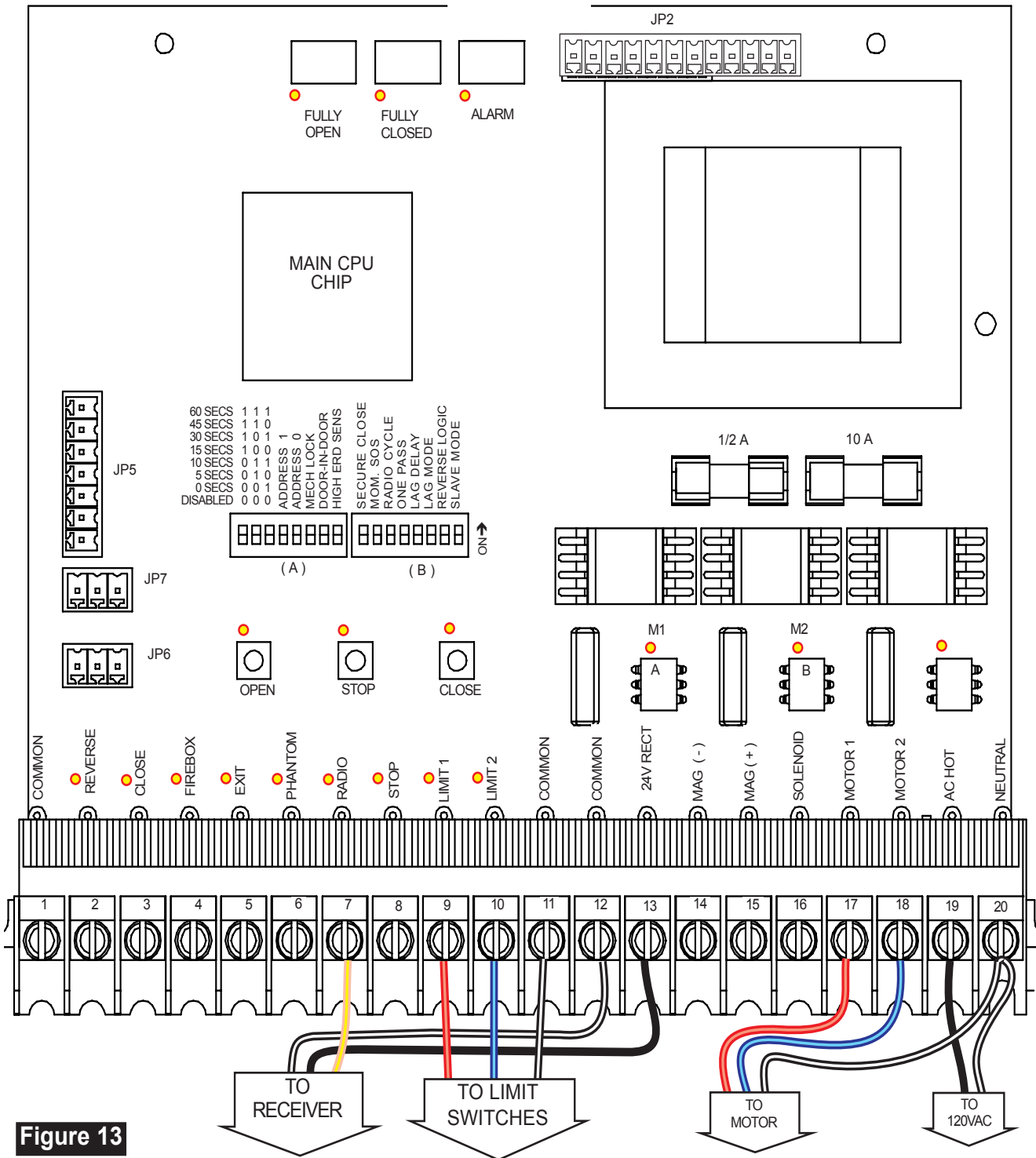

**Figure 13**

# INTELLIGATE PCB MOTOR CONTROLLER SPECIFICATIONS

## INTRODUCTION

Ramset's "Intelligate" Control board is for operating a vehicular gate operator. The control board is available for either 110VAC or 220VAC, single phase, applications. The control board contains self adjusting ERD, left hand/right hand operation control, lead/lag capability, one-pass anti-tailgating, and options for 4 different gate addresses. The control board also includes a rectified 24V, 750mA, output for providing power to peripheral devices such as radio receivers, keypads, alarms, phone entry systems, safety detectors...etc.

## DIP SWITCH CONFIGURATION

**Dip Switch A1 – 3:** Automatic Timer to Close Gate

DIP	GATE OPEN DURATION
111	60 seconds
110	45 seconds
101	30 seconds
100	15 seconds
011	10 seconds
010	5 seconds
001	0 seconds
000	disabled – command required to close

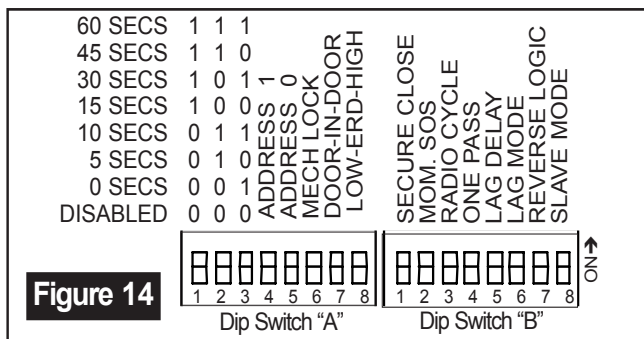

**Figure 14**

**Dip Switch A4 – 5:** "ADDRESS 1 & ADDRESS 0"

Up to four separate entrance addresses are available for installations with multiple entrance or exit locations. Master and slave gates that work together should be set to the same address. (Side gates use the address setup)

DIP	FUNCTION
00	Default – Entrance 1
01	Entrance 2
10	Entrance 3
11	Entrance 4

**Dip Switch A6:** "MECH. LOCK"

Mechanical Lock

For motor assemblies that use a mechanical lock mechanism.

DIP	FUNCTION
'off'	no effect
'on'	"Solenoid" output, on the terminal strip is used to disengage the mechanical lock prior to actuating the motor in either direction.

**DIP SWITCH A7:** "DOOR-IN-DOOR"

Door-In-Door

Used with a three button switch or a pedestrian entrance to stop the gate.

**DIP FUNCTION**

'off'	normal operation
'on'	normally closed contact. With an open contact the board will stop the gate from moving until a close contact is reached.

**DIP SWITCH A8:** "LOW - ERD - HIGH"

ERD Sensitivity

**DIP FUNCTION**

'off'	Normal ERD sensitivity – Adjusts the ERD for standard sensitivity.
'on'	Adjusts the ERD sensitivity so that more pressure is needed to stop the gate. ( <i>recommended: only use in windy areas</i> )

**DIP SWITCH B1:** "SECURE CLOSE"

Secure Close

**DIP FUNCTION**

'off'	Normal operation
'on'	When power is lost, then regained, control board checks status of gate. If open and safety devices are cleared, gate will close automatically.

### \*WARNING\*

**When installing or servicing an operator, make sure switch is off. If switch is 'on' gate will move when power is applied and severe injury may occur.**

**DIP SWITCH B2:** "MOM. SOS"

SOS Maintained/Momentary (Uses Firebox input)

**DIP FUNCTION**

'off'	Maintained contact closure – normal operation, releases when contact closure is cleared.
'on'	Momentary contact closure – releases only after a second closed contact signal is received.

**DIP SWITCH B3:** "RADIO CYCLE"

**DIP FUNCTION**

'off'	Normal operation – gate only opens and closes on the limit switches. If the gate is in travel then it will always open.
'on'	Cycle mode – gate opens and closes on the limit switches, but if in travel, then it will stop with a first command and reverse with a second command.

**DIP SWITCH B4:** "ONE PASS"

**DIP FUNCTION**

'off'	Normal operation - fully opens and closes
'on'	One pass mode - The gate will open until the "reversing loop" is initially activated and then cleared. The gate will then close. If the "reversing loop" is then activated again, before the gate is fully closed, the gate will stop until the "reversing loop" is cleared, then continue to close.

### **DIP SWITCH B5: “LAG DELAY”**

Lag on Close  
One second lag on close

### **DIP SWITCH B6: “LAG MODE”**

Lag on Open  
One second lag on open

**Note:** if both B5 & B6 are 'on', there will be NO lag on the open or close.

### **DIP SWITCH B7: “REVERSE LOGIC”**

#### **DIP FUNCTION**

‘off’ Left hand operation – standard installation  
‘on’ Right hand installations – Reverses motor & limit switches without having to move any wires.

### **DIP SWITCH B8: “SLAVE MODE”**

Master/slave

#### **DIP FUNCTION**

‘off’ Master mode – single gate operation. All peripheral devices are to be connected to the master operator.  
  
‘on’ Slave mode – used to synchronize operation between two gates. Commands are received from the master through a 3-wire, shielded cable.

## **TERMINAL STRIP CONNECTIONS**

### **CONTROL INPUT DESCRIPTIONS**

**AC Hot & Neutral** – 110 or 220 VAC to power the operator. Voltage is predetermined at factory and cannot be changed by the installer or technician.

**Close** – Closes the gate. Used with three button stations or pushbuttons. Becomes active with a closed contact to common.

**Exit** – Opens the gate. Used with loop detectors, photo eyes, keypads, phone entry systems, three-button stations...etc. Becomes active with a closed contact to common.

**Firebox/SOS** – Opens the gate. Used with fire dept. key switches & controls. Becomes active with a closed contact to common, maintained or momentary depending on dip switch B2 (see “dip switch features”).

**Stop** – Stops the operator from moving. To be used as a non-contact sensor such as a photo-beam, edge connector or a three-button station. Becomes active with an open contact to common when dip switch A7 is in the ‘on’ position (see “dip switch features”).

**Radio** – Operation depends on dip switch B3 (see “dip switch features”). Used with an RF receiver or pushbutton. Becomes active with a closed contact to common.

## **SAFETY INPUT DESCRIPTION**

**Limit 1 & Limit 2** – Depending on dip switch B7 (see “dip switch features”), stops the motor from moving in one direction. These wires are preset in factory and should not be moved. Becomes active with a closed contact to common.

**Phantom** – Keeps the gate open when the open limit switch (A or B) is activated. Used with loop detectors. Becomes active with a closed contact to common.

**Rev Loop** – Stops the gate from closing. If the gate is open, it holds the gate open. If the gate is closing, it stops and reopens the gate. If the gate is closed, the gate will remain closed. The function can be altered with dip switch B4 (see “dip switch features”). Used with loop detectors, photo eyes, safety edges...etc. Becomes active with a closed contact to common.

## **OUTPUTS**

### **Mag (+) & Mag (-)**

Supplies 24VDC to a magnetic lock when gate is closed. If gate is not closed then no power is supplied. Leave open if not used.

**Motor 1 & Motor 2** – Supplies power to the motor. Direction depends on dip switch B7 (see “dip switch features”). These wires are preset and connected in the factory and should not be moved.

**24V Rect.** – Provides a rectified 24VDC for peripheral accessories.

**Solenoid** – Sends 110 VAC to a solenoid or other mechanical lock. Leave open if not used.

## **OTHER CONNECTIONS**

### **Contact Closure Relay Outputs**

Three separate isolated form-C relay outputs are provided. Each relays contact is rated at 125VAC, 2 amps.

1. Alarm – When ERD is triggered twice, before reaching a fully closed or fully opened position, 24VDC is supplied for 6 minutes and the control board will not accept any commands. After the 6 minutes the 24VDC is removed and the board resets to normal operation.
2. Triggers relay when gate is fully opened. Used with indicator lights, buzzers, beepers, misc. voltage magnetic locks...etc.
3. Triggers relay when gate is fully closed. Used with indicator lights, buzzers, beepers, misc. voltage magnetic locks...etc.

Electronic Control Board must be serviced by a certified technician only.

Power must be turned OFF before servicing operator.

Power must be turned OFF before attempting to adjust the limit switches.

Power must be turned OFF for power failure release.

### WIRING DIAGRAM

Figure 15

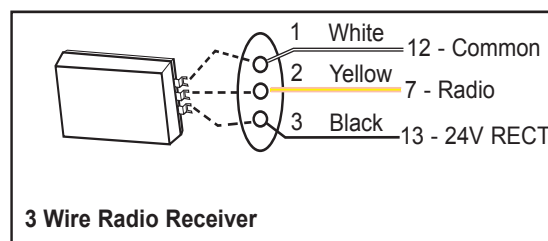
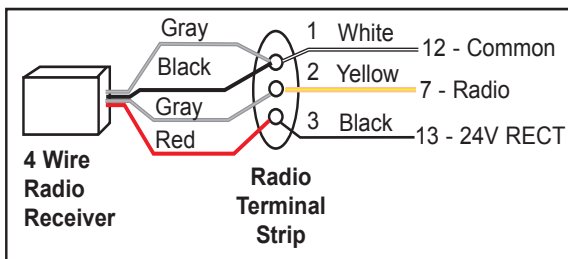
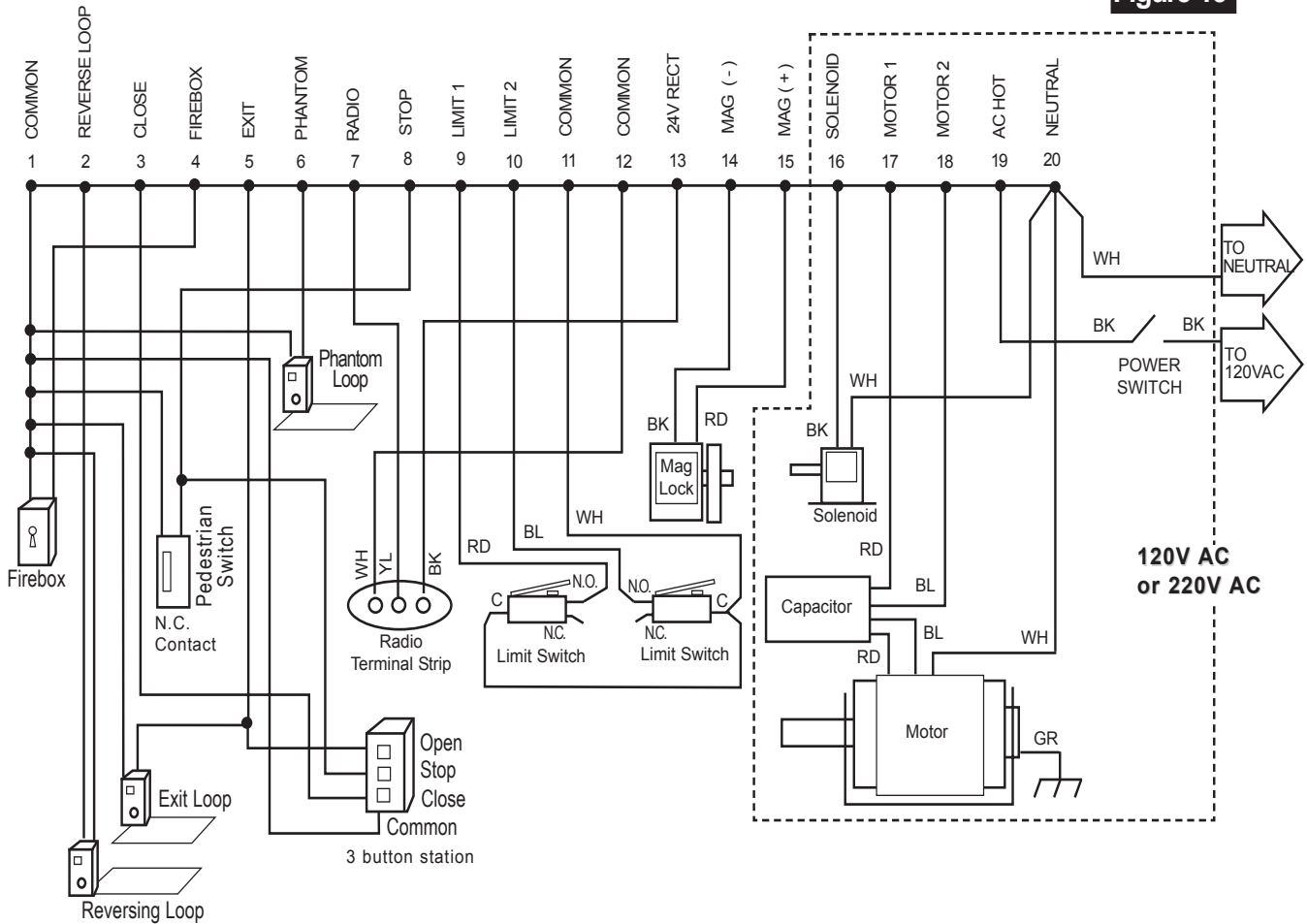

Legend	
RD	= Red
WH	= White
BL	= Blue
GR	= Green (Ground)
BK	= Black
YL	= Yellow

## SENSOR INSTALLATION

### ⚠ WARNING

A non-contact sensor (photoelectric sensor or equivalent) and a contact sensor (edge device or equivalent) is required on each individual installation to comply with UL325.

**Reversing Sensors** on the ground floor prevent gate from closing when vehicle is in loop area.  
**Exit Loops** on the ground floor opens gate when vehicle crosses loop area.

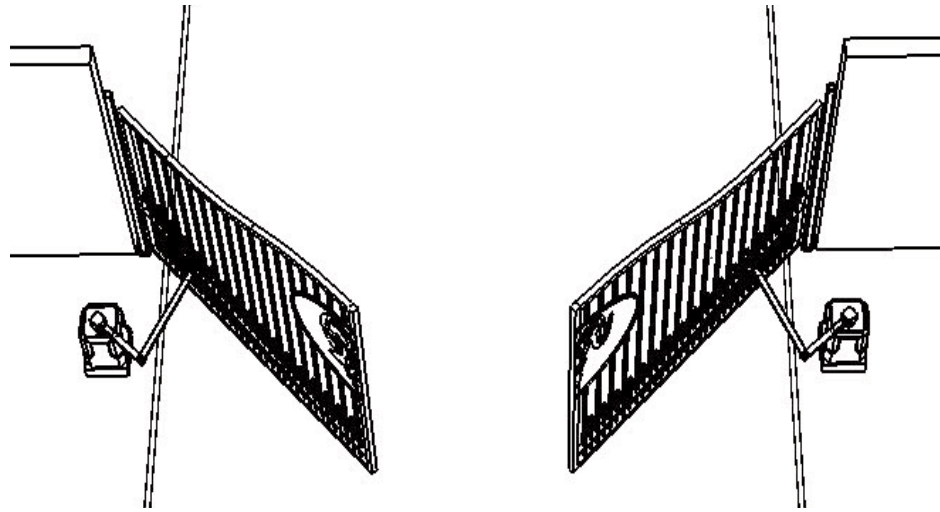
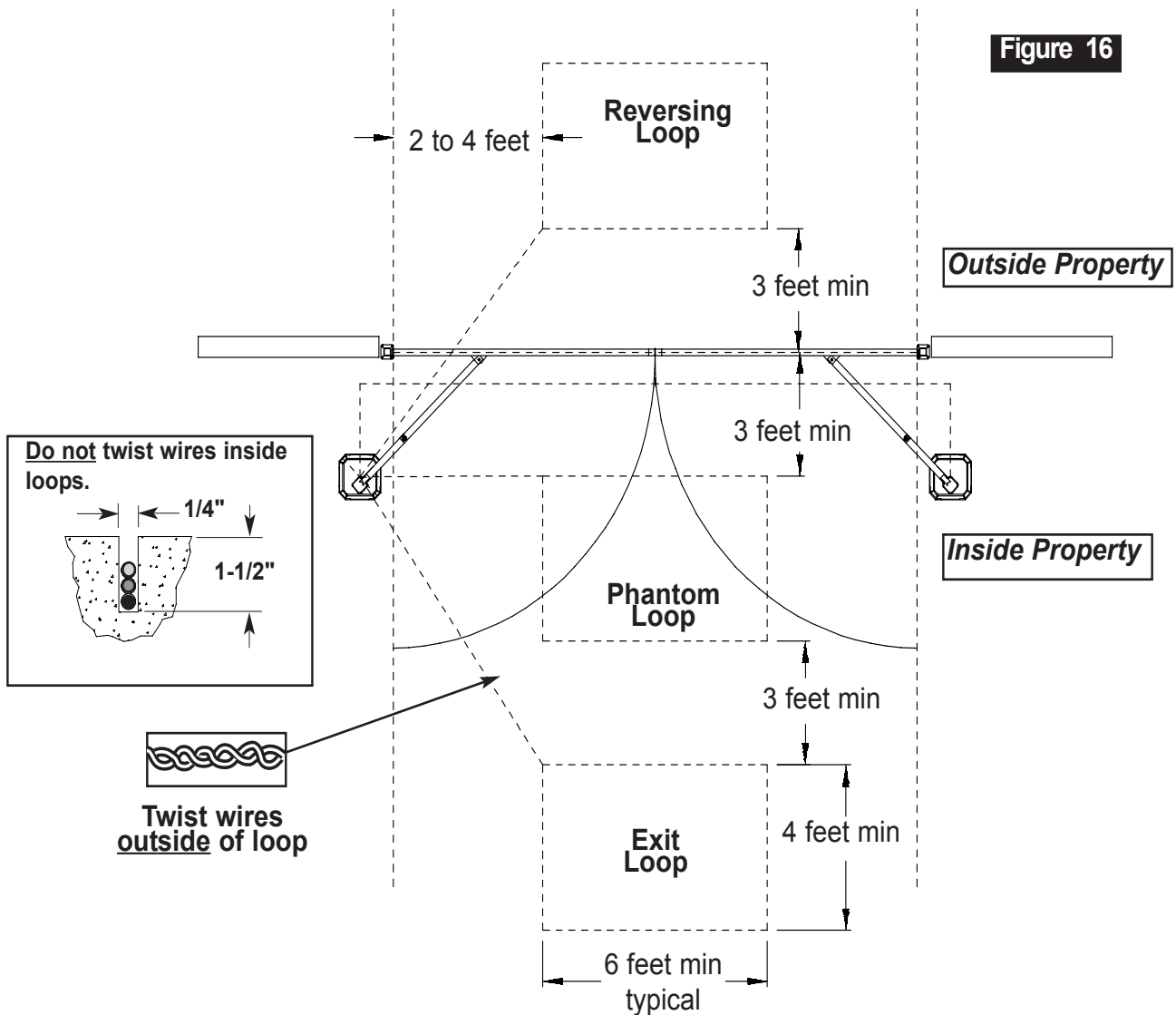
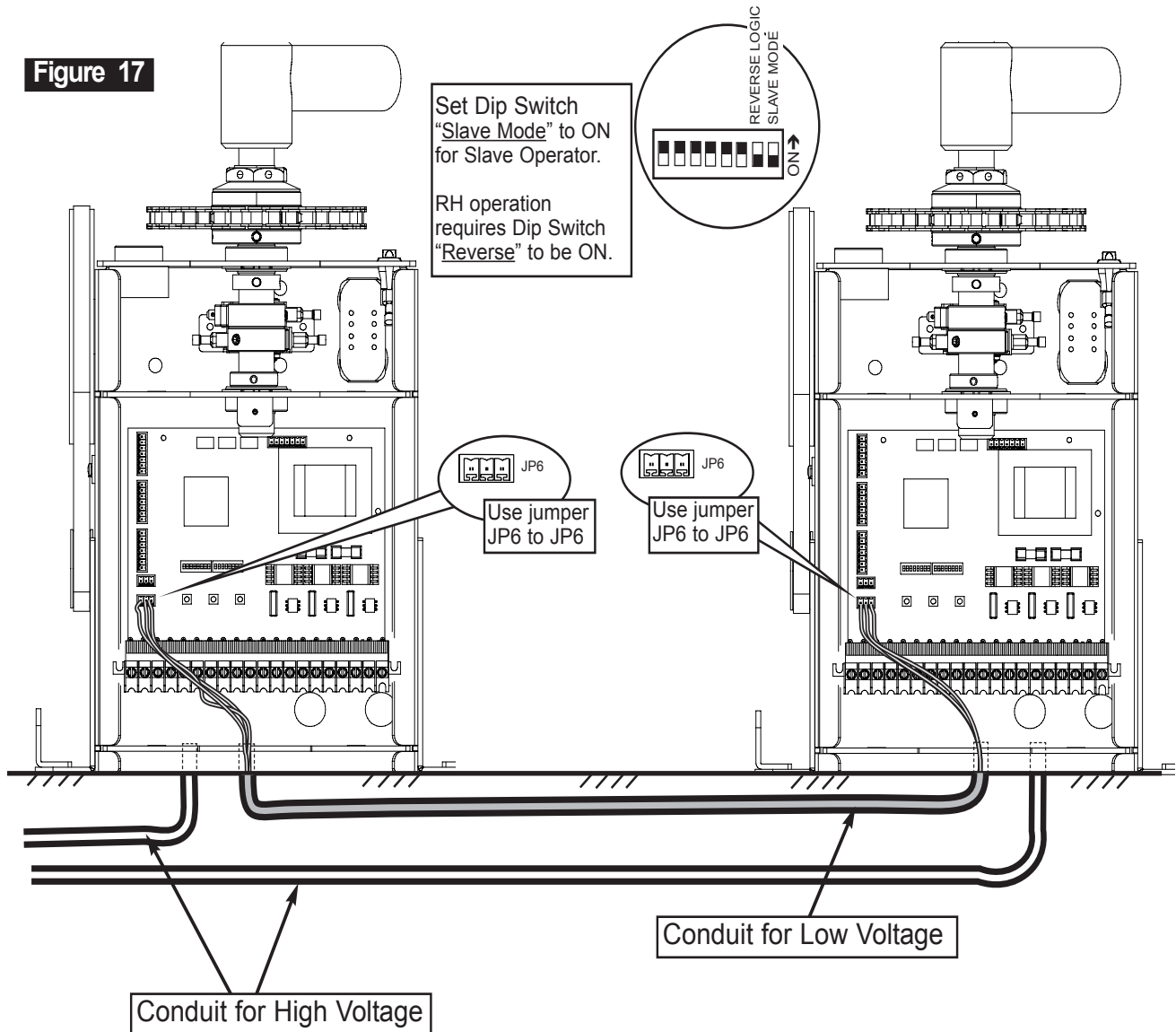

Figure 16



## MASTER-SLAVE INSTALLATION

Figure 17



Use 3-stranded, shielded wires (not supplied) from Master to Slave. Route low-voltage wires for Master/Slave in a conduit separate from power. Keep conduits at least 3 inches apart.

Set dip switch B-8 to "ON" on operator designated to be "Slave".  
Set dip switch B-7 to reverse for RH operation.



**BILL OF MATERIAL FOR RAM-30**

ITEM	PART #	PART DESCRIPTION FOR RAM-30	PIECES
			PER UNIT
1	50-026	gear reducer size 50	1
2	50-033	1/2 hp 115 vac electric motor	1
3	50-039	20 pin edge connector	1
4	50-050	40 b 12 7/8" sprocket	1
5	50-069	limit switch 00-h3	2
6	50-084	# 40 drive chain	1
7	50-095	5/16-18 x 3/4" hex head bolt	10
8	50-096	5/16 lock washer	8
9	50-097	5/16 flat washer	6
10	50-104	5/16 hex head nut	4
11	50-105	#6-40 Keps Nut	2
12	50-107	# 6 x 3/8" machine screw	5
13	50-110	1/2-14 x 2 1/2" hex head bolt	1
14	50-113	1/2-14 hex head nut	2
15	50-114	1/4-20 socket head	4
16	50-127	2 1/2" torque limiter arbor	1
17	50-128	2 1/2" torque limiter washer	1
18	50-129	2 1/2" torque limiter friction disc	2
19	50-130	2 1/2" torque limiter tension washer	1
20	50-131	1-3/4" torque limiter nut	1
21	50-151	warning cards for gate	2
22	50-168	horn alarm	1
23	50-181	torque limiter bushing	1
24	50-183	limit switch bracket	1
25	50-205	capacitor	1
26	50-215	rocker switch	1
27	50-218	motor clamp	2
28	50-219	# 10 x 1-1/2 machine screw	2
29	50-220	plastic grommet	3
30	50-221	# 10 square nut	2
31	50-247	3/4 sealed ball bearings	2
32	50-253	3/4" collar shaft	2
33	50-265	3/16" x 3/4" keyway	1
34	50-294	motor base plate	1
35	50-299	radio receiver terminal	1
36	50-401	10 ga. Heavy duty metal chassis	1
37	50-402	board metal cover	1
38	50-403	polyethylene cover	1
39	50-404	3/4" x 10" limit switch shaft	1
40	50-405	40 a 27 sprocket	1
41	50-406	3/4" limit switch cam	2
42	50-407	1/2" x 1 1/2" cast iron pulley	1
43	50-408	6" aluminum pulley	1
44	50-409	4L v belt # 250	1
45	50-410	pivot arm	1
46	50-411	swivel center arm	1
47	50-412	1 1/4" metal pipe arm ( short )	1
48	50-413	1 1/4" metal pipe arm ( long )	1
49	50-414	polyethylene external top cap	1
50	50-418	internal gate bracket for swing arm	1
51	50-419	external gate bracket	1
52	50-420	uhmw arm spacer	3
53	50-511	120 vac double outlet	1
54	50-520	# 6 x 5/8" machine screw	2
55	50-526	# 6 x 1/4" machine screw	2
56	50-527	1/4" x 1" keyway	1
57	50-528	# 8 x 3/8" machine screw	1
58	50-529	# 6 x 2" machine screw	2
59	50-777	intelligate control board	1





# MODEL RAM-30 UL PARTS DIAGRAM

Figure 18

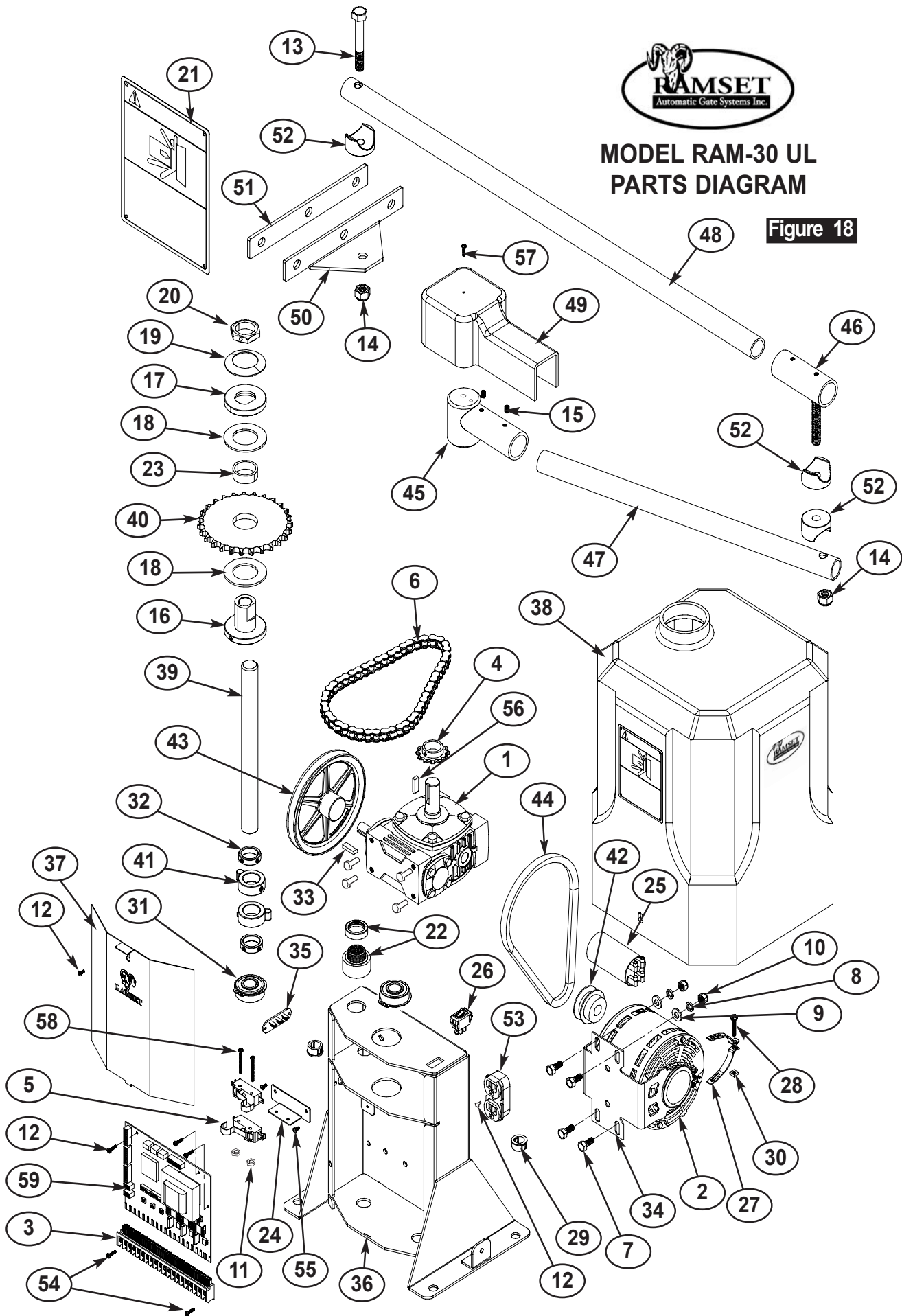

## GLOSSARY

### CLASSES OF VEHICULAR GATE OPERATORS

**VEHICULAR HORIZONTAL SLIDE-GATE OPERATOR (OR SYSTEM)**- A vehicular gate operator (or system) that controls a gate which slides in a horizontal direction that is intended for use for vehicular entrance or exit to a drive, parking lot, or the like.

**VEHICULAR SWING-GATE OPERATOR (OR SYSTEM)** - A vehicular gate operator (or system) that controls a gate which swings in an arc in a horizontal plane that is intended for use for vehicular entrance or exit to a drive, parking lot or the like.

**RESIDENTIAL VEHICULAR GATE OPERATOR-CLASS I** - A vehicular gate operator (or system) intended for use in a home of one-to four single family dwellings, or a garage or parking area associated therewith.

**COMMERCIAL/GENERAL ACCESS VEHICULAR GATE OPERATOR- CLASS II**- A vehicular gate operator (or system) intended for use in an commercial location or building such as a multi-family housing unit (five or more single family units), hotels, garages, retail stores, or other buildings serving the general public.

**INDUSTRIAL/LIMITED ACCESS VEHICULAR GATE OPERATOR - CLASS III** - A vehicular gate operator (or system) intended for use in an industrial location or building such as a factory or loading dock area or other locations not intended to service the general public.

**RESTRICTED ACCESS VEHICULAR GATE OPERATOR - CLASS IV** - A vehicular gate operator (or system) intended for use in a guarded industrial location or building such as an airport security area or other restricted access locations not servicing the general public, in which unauthorized access is prevented via supervision by security personnel.

VISIT OUR WEBSITE AT: [WWW.RAMSETINC.COM](http://WWW.RAMSETINC.COM)

Ramset Automatic Gate Systems ● (800) 771-7055 ● 9116 De Garmo Ave. ● Sun Valley, CA. 91352