

# K500

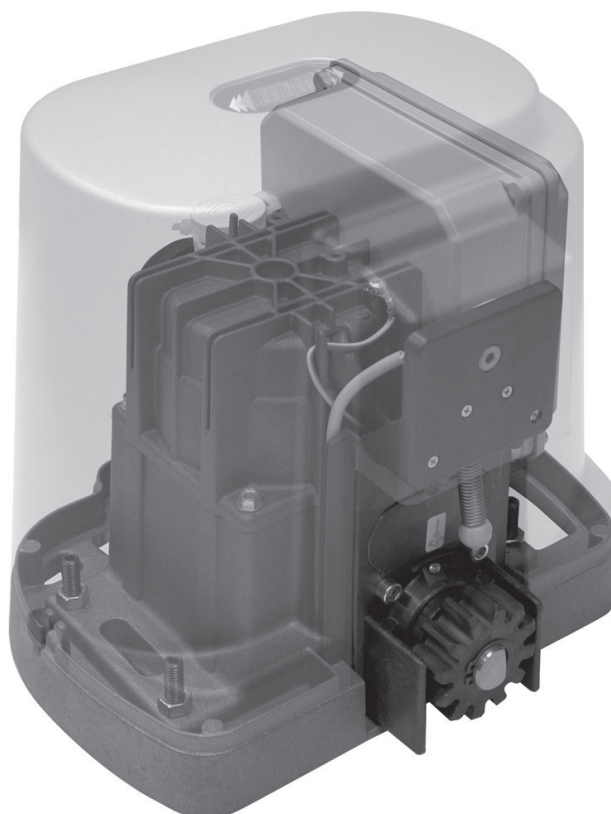

Con funzionamento a uomo presente se le fotocellule o le coste sono guaste.

Avec travail avec homme present, dans le cas de panne de sécurité.

With functioning in dead man mode when the safety devices are failing.

Mit arbeit im mannsbeisein im fall eines ausfalls der sicherheiten.

Con funcionamiento a hombre presente en caso de averías con los accesorios de seguridad.

Operatore Operateur Operator Torantrieb Operador	Alimentazione Alimentation Power Supply Stromspannung Alimentacion	Con quadro Avec coffret With control board Mit Steuerung Con panel electronico	Peso max cancello Poids maxi portail Max gate weight Max Torgewicht Peso máx verja	Spinta max Poussée maxi Max Thrust Max Schubkraft Max Empuje	Coppia max Couple maxi Max torque Max. Drehmoment Coppia max	Codice Code Code Code Codigo
K500	230V 50/60Hz	-	500 kg / 1103 lbs	400 N	9,5 Nm	AA33694
		K-CRX				AA33695
		K				AA33753
		K-Wi-Fi				AA33753W
	120V 60Hz	-		500 N	12Nm	AA33693
		K				AA33696

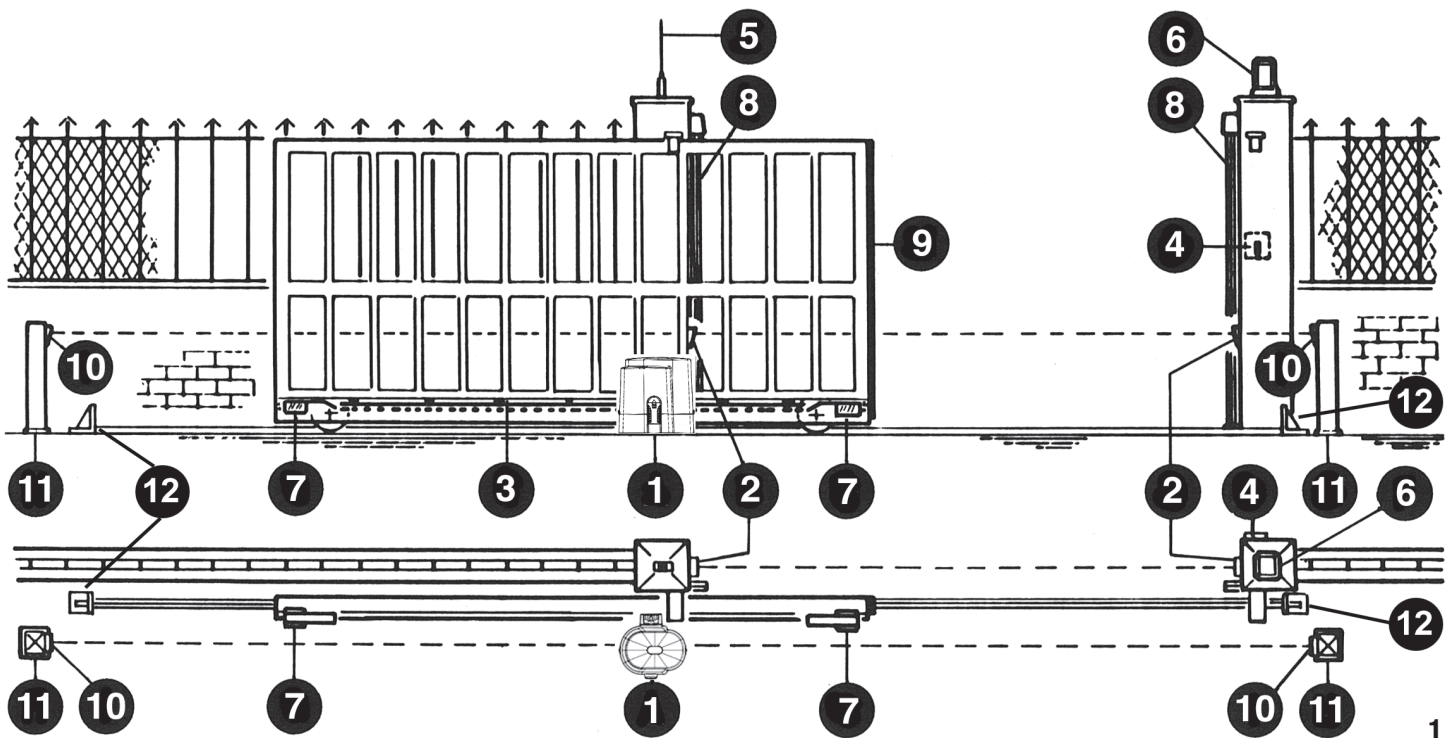

- 1 - K500 operating device
- 2 - External photocells
- 3 - Rack of Module 4
- 4 - Key selector
- 5 - Radio antenna
- 6 - Blinker
- 7 - Limit switch plate (cams)
- 8 - Mechanical strip
- 9 - Pneumatic strip or Fotocosta
- 10 - Internal Photocells
- 11 - Photocell columns
- 12 - Mechanical stops

## TECHNICAL FEATURES

**Irreversible operating devices for sliding gates with a maximum weight of 500 kg / 4900 lbs.**

The irreversibility of this operating device allows you to avoid using any electric lock for an effective closing of the gate. The motor is protected by a heat probe, that temporarily interrupts the operating cycle in case of prolonged use.

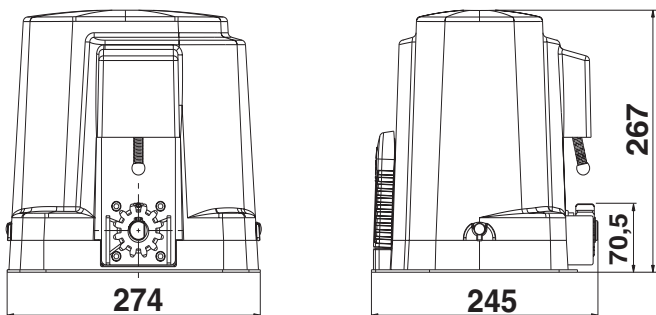

Measurements in mm

TECHNICAL DATA		K500	
Max. leaf weight	kg	500	
Rack		4	
<b>EEC Power supply</b>		<b>230V~ 50Hz</b>	<b>230V~ 60Hz</b>
Thrust force with constant turns	N	400	
Max torque	Nm	9,5	
Motor capacity	W	229	228
Power absorbed	A	1,21	1,05
Capacitor	µF	10	
<b>Power supply 120V</b>		<b>120V~ 60Hz</b>	
Thrust force with constant turns	N	500	
Max torque	Nm	12	
Motor capacity	W	259	
Power absorbed	A	3,5	
Capacitor	µF	35	
Normative cycles 230V/50Hz	n°	12 - 30s/2s	
Normative cycles 220V/60Hz	n°	10 - 30s/2s	
Normative cycles 120V/60Hz	n°	9 - 30s/2s	
Daily operations suggested	n°	300	
Service		60%	
Guaranteed consecutive cycles	n°	25/5m	
Grease		COMLUBE LHITGREASE EP/GR.2	
Weight of electroreducer	kg	8	
Noise	db	<70	
Working temperature	°C	-10 ÷ +55	
Protection	IP	54	

## CHECKING BEFORE THE INSTALLATION

**!! THE GATE SHALL MOVE FRICTIONLESS !!**

**N.B.:** Gate features must be uniformed with the standards and laws in force. The door/gate can be automated only if it is in a good condition and its conditions comply with the EN 12604 norm.

- The door/gate leaf does not have a pedestrian door. In the opposite case it is necessary to take the appropriate steps, in accordance with EN 12453 norm (for instance; by preventing the operation of the motor when the pedestrian door is opened, by installing a safety microswitch connected with the control panel).
- Besides the electrical or mechanical limit switches available on the operators, there must be, on both ends of the installation, a fixed mechanical stopper which stop the gate in the unlikely event of ill functioning of limit switches on the operators. For this reason the fixed mechanical stopper must be of an adequate size to withstand the static and kinetic forces generated by the gate (12) (fig. 2).
- Gate columns shall have anti-derailment guides on their top (fig. 3), to avoid the unintentional gate release.

**N.B.:** Remove mechanical stops like the one in fig. 3.

No mechanical stops shall be on top of the gate, since these mechanical stops are not safe enough.

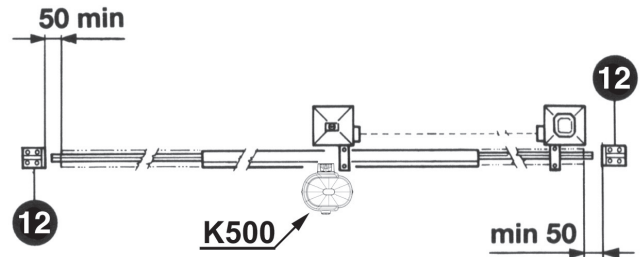

2

Parts to install meeting the EN 12453 standard			
COMMAND TYPE	USE OF THE SHUTTER		
	Skilled persons (out of public area*)	Skilled persons (public area)	Unrestricted use
with manned operation	A	B	non possible
with visible impulses (e.g. sensor)	C or E	C or E	C and D, or E
with not visible impulses (e.g. remote control device)	C or E	C and D, or E	C and D, or E
automatic	C and D, or E	C and D, or E	C and D, or E

\* a typical example are those shutters which do not have access to any public way  
 A: Command button with manned operation (that is, operating as long as activated), like code ACG2013  
 B: Key selector with manned operation, like code ACG1010  
 C: Adjustable power of the motor  
 D: Safety strips and/or other safety devices to keep thrust force within the limits of EN12453 regulation - Appendix A.  
 E: Photocells, like code ACG8026 (To apply every 60÷70cm for all the height of the column of the gate up to a maximum of 2,5m - EN 12445 point 7.3.2.1)

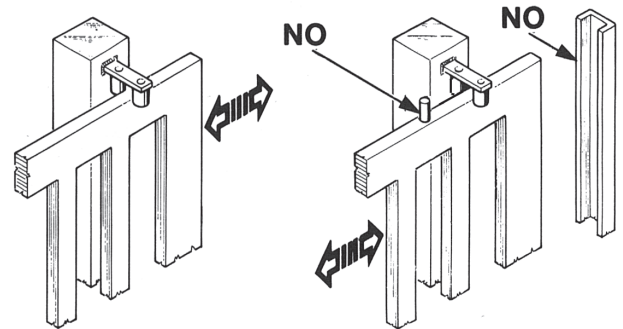

3

## RELEASE

**To operated after the power supply to the motor has been interrupted.**

In order to work manually on the gate, you just need to insert the fitting key and rotate it 3 times counterclockwise (fig. 4).

In order to carry out the manual operation of the gate leaf the followings must be checked:

- That the gate is endowed with appropriate handles;
- That these appropriate handles are placed so to avoid safety risks for the operator;
- That the physical effort necessary to move the gate leaf should not be higher than 225 N, for doors/gates for private dwellings, and, 390N for doors/gates for commercial and industrial sites (values indicated in 5.3.5 of the EN 12453 norm).

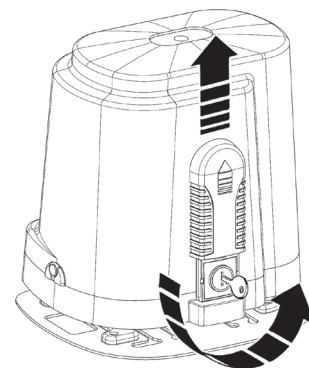

4

### MOTOR AND RACK FITTING

Operator K500 comes with a base plate for vertical adjustment. Such adjustment proves to be useful to set a 1mm clearance between the drive gear and the rack.

The base plate is provided with three brackets that can be used to fasten the equipment to the floor. As an alternative, it is possible to obtain the special to type plate for type K500 (code ACG8108) to be secured directly to the floor.

In addition, it is possible to install the equipment K500 complete with base plate, directly over the installation plate, as suitable for operator K5 (code ACG8101).

The base plate for operator K500 features four holes for floor securing, through four expansion studs.

The rack shall be fitted over the motor support, at a certain distance from it.

Its height can be adjusted thanks to the holes in the rack.

The height is adjusted to prevent the gate from resting on the driving gear of the K as it moves (Fig. 5, 6).

To fix the rack on the gate, drill some  $\varnothing 5$  mm holes and thread them using an M6 screw tap.

The driving gear needs some 1 mm clearance from the rack.

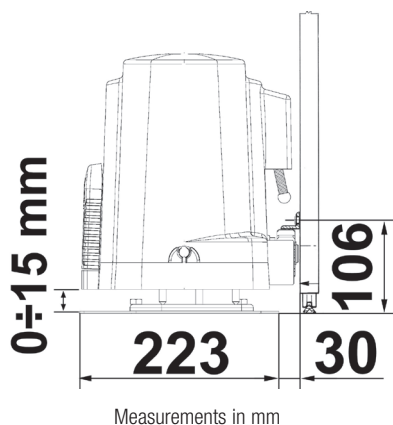

5

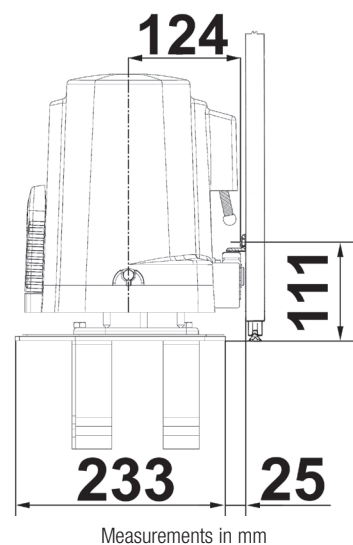

6

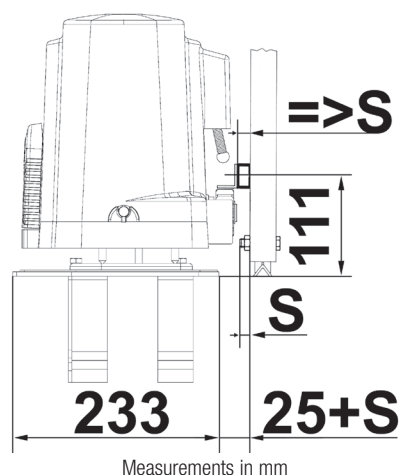

7

### LIMIT SWITCH FITTING

In order to determine the travel of the moving part, place two cams at the ends of the rack (Fig. 9).

Move the cams on the rack teeth to adjust their opening and closing travel.

To fix the cams to the rack, tighten the screws issued.

N.B: In addition to the electric stop cams mentioned above, you must also install strong mechanical stops preventing the gate from sliding out of the top guides.

### MAINTENANCE

To be carried out exclusively by skilled persons after the power supply to the motor has been interrupted.

Periodically, when the gate is standstill, clean and keep the guide free from stones and dirt.

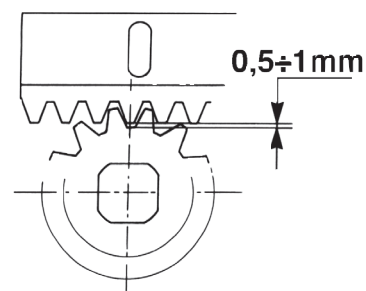

8



9

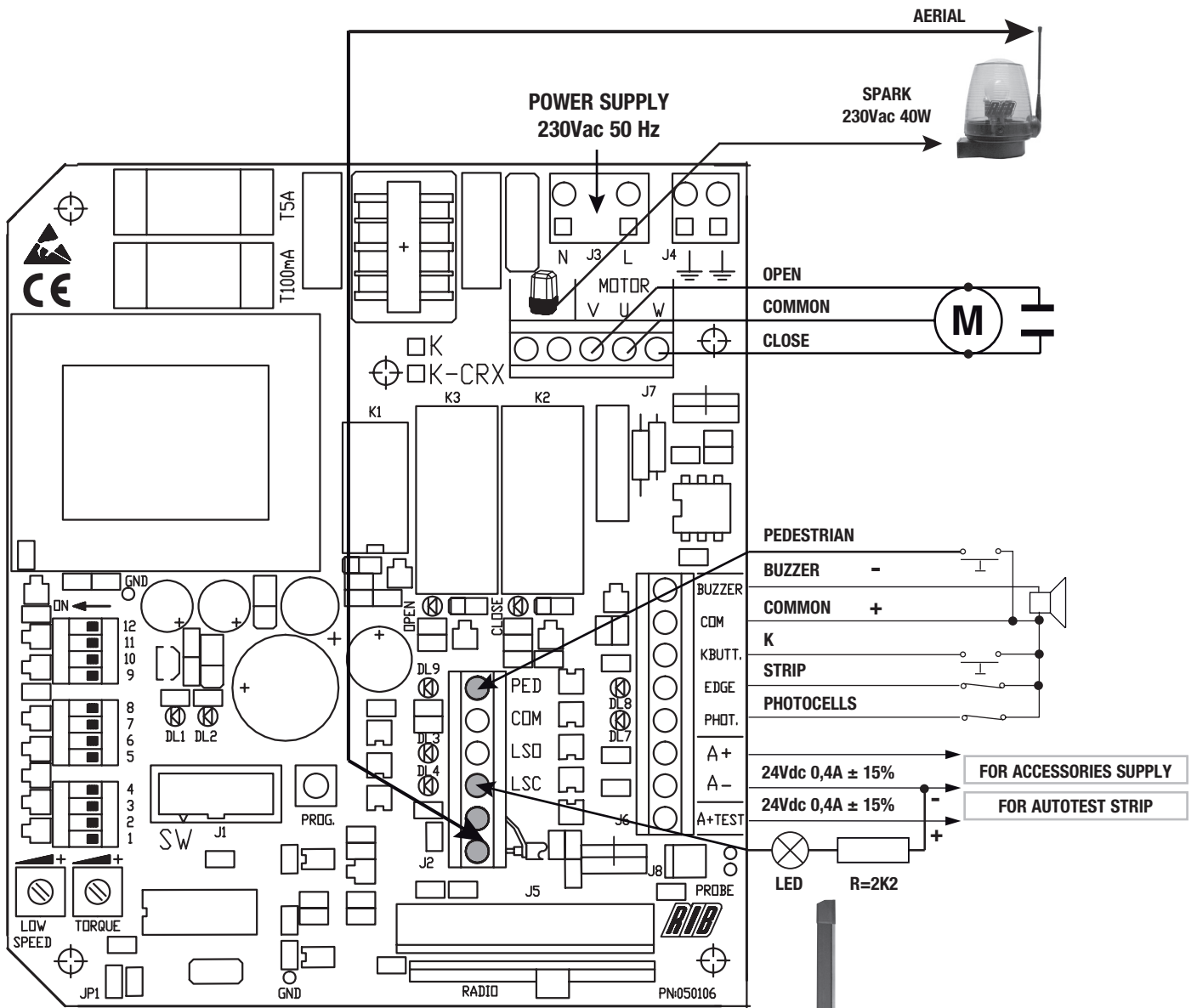

K / PEDESTRIAN  
KEY SELECTORS BLOCK  
AND PUSH-BUTTON FLAT



PHOTOCELLS  
FIT SLIM

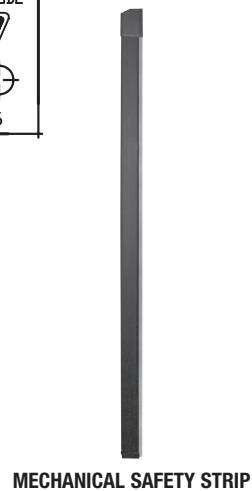

MECHANICAL SAFETY STRIP

J1	NO CRX CRX	DO NOT REMOVE ANY JUMPER! OTHERWISE THE OPERATOR WILL NOT WORK!
J2	AERIAL	Radio Antenna
	LSC	Close limit-switch that cuts off the motor in closing
	LSO	Open limit-switch that cuts off the motor in opening
	COM	Limit-switch common contact
	PED BUTT	Pedestrian opening contact (NO)
J3	L-N	Main power supply 230 Vac 50/60 Hz (120V/60Hz upon request)
J4	EARTH 	Connection of the earth line
J5	RADIO	Built-in radio module (model CRX), or connector for radio receiver RIB, 24Vdc supply
J6	A+ TEST	24Vdc safety strip self-test power supply
	A+	Accessories power supply +24Vdc
	A-	Accessories power supply -24Vdc
	COM +	Common contact (common line for all the command and safety inputs) (+)
	K BUTT.	Single pulse contact (NO)
	PHOT.	Photocells contact (NC)
	EDGE	Safety strip contact (NC)
		Buzzer contact (24Vdc max 200 mA) (-)
J7		Flashing light (max 40W)
	U - MOTOR	Motor common connection
	V-W - MOTOR	Motor phase and capacitor connections
J8	PROBE	Temperature sensor cable connection PROBE (Code ACG4665 optional)

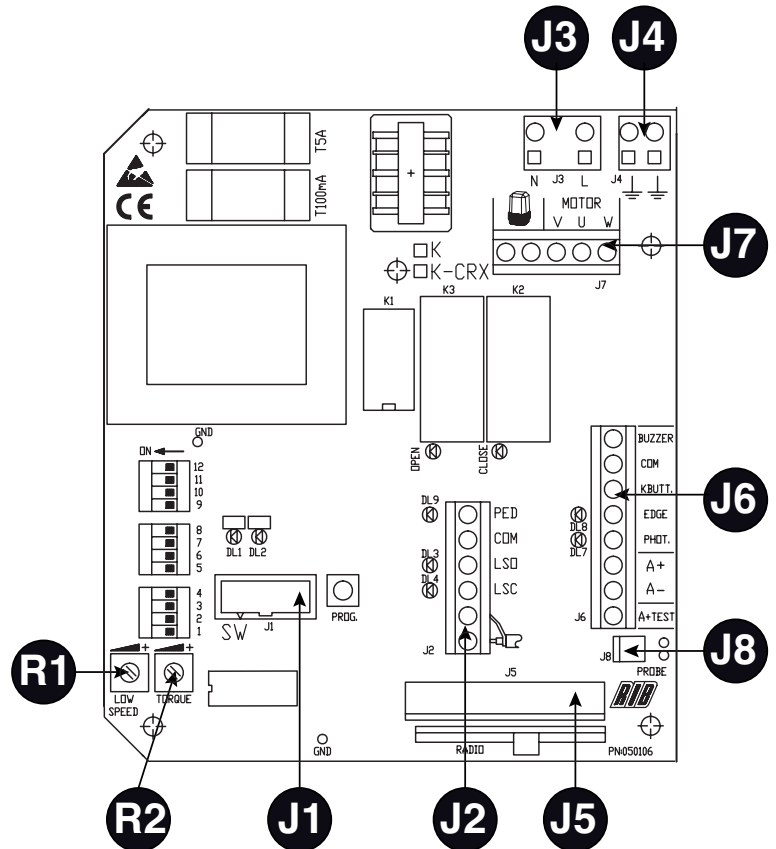

R1	TRIMMER LOW SPEED	Electronic regulator for low speed on approach
R2	TRIMMER TORQUE	Electronic torque regulator

### RELAYS AND MOTOR COMMAND

- K1 => Flashing light command
- K2 => Closing command
- K3 => Opening command
- Q1 => TRIAC - Motor command in opening and closing

### POINT B - SETTINGS

- DIP 1 MOTOR ROTATION DIRECTION CHECK (See Point C)**
- DIP 2 PROGRAMMING (See Point D)**
- DIP 2-1 PROGRAMMING OF THE PEDESTRIAN OPENING (See Point D)**
- DIP 1-2 STORAGE/DELETION OF RADIO CODES FOR COMPLETE OPENING (DIP 1 ON followed by DIP 2 ON) (POINT F) ONLY FOR CRX MODELS**
- DIP 1-3 STORAGE/DELETION OF RADIO CODES FOR PEDESTRIAN OPENING (DIP 1 ON followed by DIP 3 ON) (POINT G) ONLY FOR CRX MODELS**



#### OPERATING MODE SETTINGS

- DIP 3** ON - Automatic Closing ENABLED  
OFF - Automatic Closing DISABLED
- DIP 4** ON - Photocells active only in closing  
OFF - Photocells always active
- DIP 5** ON - blinker pre-flashing  
OFF - blinker normal-flashing
- DIP 6** ON - STEP BY STEP  
Single pulse contact (K BUTT)  
Pedestrian button (PED BUTT)  
Radio Receiver command  
OFF - AUTOMATIC  
Single pulse contact (K BUTT)  
Pedestrian button (PED BUTT)

- Radio Receiver command
- DIP 7** ON - electronic brake ENABLED  
OFF - electronic brake DISABLED
- DIP 8** ON - low speed in approaching DISABLED  
OFF - low speed in approaching ENABLED
- DIP 9** ON - gradual start ENABLED  
OFF - gradual start DISABLED
- DIP 10** ON - safety strip self-test ENABLED  
OFF - safety strip self-test DISABLED
- DIP 11** ON
- DIP 12** OFF
- S1** => PROG. Programming button.

#### TORQUE => R1 Electronic regulator for motor torque

Adjustment of motor torque is carried out using the TORQUE Trimmer which varies the output voltage to the head/s of the motor/s (turn clockwise to increase torque). This torque control is activated after 2 seconds from any manoeuvre begging, whereas the motor is turned on at full power to guarantee the starting at the manoeuvre begging.

**PAY ATTENTION: IF THE TORQUE TRIMMER SETTING IS CHANGED, IT IS PREFERABLE TO REPEAT THE TIME PROGRAMMING.**

#### LOW SPEED => R1 Electronic regulator for low speed on approach

Adjustment of low speed is carried out using the LOW SPEED Trimmer which varies the output voltage to the head/s of the motor/s (turn clockwise to increase speed). Adjustment is carried out to establish the correct speed at the completion of opening and closing, depending on the structure of the gate, or if there is any light friction that could compromise the correct working of the system. The low speed is activated (DIP8 OFF) when the gate leaf is 0.50-0.60 meters away from the complete close or open position.



**ELECTRONIC BRAKE**

If the low speed in approaching is disabled (DIP8 ON), it is preferable to turn the DIP7 ON to enable at least the electronic brake that permits to win the gate leaf inertia when the gate reaches the close or open limit switches.

**GRADUAL START**

With DIP 9 in the ON mode, the gate starts to move gradually for 1 second only.

**LED WARNING**

- DL1 - programming activated (red)
- DL2 - radio code programming (green) (CRX version only)
- DL3 - open limit-switch contact (NC) (red)
- DL4 - close limit-switch contact (NC) (red)
- DL5 - gate closing M1 (red)
- DL6 - gate opening (green)
- DL7 - photocell contact (NC) (red)
- DL8 - safety strip contact (NC) (red)
- DL9 - Pedestrian opening button (red)

**POINT C - MOTOR ROTATION DIRECTION CHECK**

This operation is meant to help the installer during the installation (commissioning) and for further future controls.

- 1 - Unlock the operator with the Manual Release, install the limit switch plates, swing open the leaf about halfway and lock the operator.
- 2 - Turn **DIP1 to ON** position, LED DL1 starts blinking
- 3 - Press and hold the PROG button, the gate will open or close. Release the button and the gate will stop. Press and hold again, the gate will move in the opposite direction.

The K control board has two movement leds

- DL6 the GREEN led for OPENING
- DL5 the RED led for CLOSING

When you press and hold the PROG button, if the gate opens with the green led on then you may proceed to step 4.

If the gate moves in the wrong direction compared with the movement leds:

- turn OFF the main AC power
- reverse the V and W motor cables position (the blue motor cable must be always in the U position)
- reverse the limit switch wires marked LSO and LSC
- turn ON the main AC power and check again the motor direction

- 4 - After 2 seconds motor starting and for the next 10 seconds motor working, **the torque control** is automatically activated. Set the motor torque by the TORQUE Trimmer which varies the output voltage to the head of the motor (turn clockwise to increase torque).
- 5 - After other 10 seconds motor working, the **low speed control** is automatically activated (DIP8 OFF). Set the motor low speed by the LOW SPEED Trimmer to select the gate leaf low speed in approaching.
- 6 - Press and hold the PROG button to close completely the gate. Turn DIP1 to OFF, the RED led DL1 will stop blinking.

**During Point C procedure, safety devices (photocells and safety strip) are not active.**

(#) In Point D and Point E procedures, all the safety devices (photocells and safety strip) will be active, so they must be properly installed and connected to the control board. Any changing of the safety devices input state, will stop the Point D and Point E procedure that must be repeated from the beginning.

**POINT D - PROGRAMMING (#)**

- 1 - The gate must be fully closed.
- 2 - Turn **DIP2 to ON** position, LED DL1 starts blinking
- 3 - **Press PROG. Button**, motor opens.
- 4 - Once reached the open position, the open limit switch will cut out motor and the gate travelling will be stored. The gap of time between now (stop of motor) and the next pressing of the PROG. button (see step 5 below) will be then stored as waiting time for Automatic Closing feature.
- 5 - **Press PROG. button**, gate closes and the Automatic Closing time is stored (see DIP3 function to enable or disable the Automatic Closing feature).
- 6 - The LED DL1 will turn OFF, signalling exit from the Point D procedure. Closing of the gate will be carried out at normal speed and only on approaching total closing at low speed (depending on the adjustment of LOW SPEED trimmer).
- 7 - When the gate leaf reaches the close limit switch plate, the motor stops.
- 8 - **Turn DIP2 to OFF** position

**During Point D procedure, safety devices (photocells and safety strip) are active.**

**POINT E - PROGRAMMING OF PEDESTRIAN OPENING (#)**

- 1 - The gate must be fully closed.
- 2 - Turn **DIP2 to ON** position, the LED DL1 starts blinking quickly
- 3 - Immediately, turn also **DIP1 to ON** position, the LED DL1 starts blinking slowly
- 4 - **Press the pedestrian pushbutton PED. BUTT**, the gate opens
- 5 - When the gate leaf is opened enough for the pedestrian crossing, **press the pedestrian pushbutton PED. BUTT** to stop the travel (thus defining the opening stroke of the motor). The gap of time between now (stop of the motor) and the next pressing of the PROG. button (see point 6 below) will be stored as waiting time for Pedestrian Automatic Closing feature.
- 6 - **Press the pedestrian pushbutton PED. BUTT**, gate closes and the Pedestrian Automatic Closing time is stored (see DIP3 function to enable or disable the Automatic Closing feature).
- 7 - **Turn DIP1 to OFF** position
- 8 - **Turn DIP2 to OFF** position

**During Point E procedure, the safety devices (photocells and safety strip) are active.**

**POINT F - PROGRAMMING RADIO CODES FOR COMPLETE OPENING (UP TO 30 CODES - ONLY FOR CRX MODELS)**

You can only programme the codes if the gate is closed.

- 1 - Position DIP 1 to ON and then DIP 2 to ON.
- 2 - The red programming DL1 LED will flash ON and OFF, one second on each, for 10 seconds.
- 3 - Press the remote control button (normally channel A) within the 10 seconds proscribed. If the remote control has been correctly programmed, the DL2 LED (green) will flash once.
- 4 - The code programming time resets automatically so that you can programme the next remote control.
- 5 - To finish programming, let 10 seconds pass and then press the PROG. button briefly. The red DL1 LED will stop flashing.
- 6 - Reposition DIP 1 to OFF and DIP 2 to OFF.
- 7 - You have completed the procedure

**PROCEDURE FOR DELETING ALL RADIO CODES USED ONLY FOR COMPLETE OPENING**

You can only delete the codes if the gate is closed.

- 1 - Position DIP 1 to ON and then DIP 2 to ON.
- 2 - The red programming DL1 LED will flash ON and OFF, one second on each, for 10 seconds.
- 3 - Press and hold the PROG button for 5 seconds. The green DL2 LED will flash twice to confirm that the stored codes have been deleted.
- 4 - The red programming DL1 LED remains active and you can programme new codes as shown above if required.
- 5 - Reposition DIP 1 to OFF and DIP 2 to OFF.
- 6 - You have completed the procedure.

**HOW TO CHECK IF THE MEMORY IS FULL FOR RADIO CODES USED ONLY FOR COMPLETE OPENING**

You can only check the memory if the gate is closed.

- 1 - Position DIP 1 to ON and then DIP 2 to ON.
- 2 - The green DL2 LED will flash 6 times if the memory is full (30 codes have been stored).
- 3 - After this, the DL1 programming LED will remain active for 10 seconds, so that you can delete all codes if required.
- 4 - Reposition DIP 1 to OFF and DIP 2 to OFF.
- 5 - You have completed the procedure

**POINT G - PROGRAMMING RADIO CODES FOR PEDESTRIAN OPENING (UP TO 30 CODES - ONLY FOR CRX MODELS)**

You can only programme the codes if the gate is closed.

- 1 - Position DIP 1 to ON and then DIP 3 to ON.
- 2 - The red programming DL1 LED will flash ON and OFF, one second on each, for 10 seconds.
- 3 - Press the remote control button (normally channel B) within the 10 seconds proscribed. If the remote control has been correctly programmed, the DL2 LED (green) will flash once.
- 4 - The code programming time resets automatically so that you can programme the next remote control.
- 5 - To finish programming, let 10 seconds pass and then press the PROG. button briefly. The red DL1 LED will stop flashing.
- 6 - Reposition DIP 1 to OFF and DIP 3 to OFF.

**N.B: IF THE DL1 LED CONTINUES TO FLASH RAPIDLY, THIS MEANS THAT DIP 1 IS STILL POSITIONED TO ON AND ANY MANOEUVRE HAS BEEN DELETED.**

- 7 - You have completed the procedure.

**PROCEDURE FOR DELETING ALL RADIO CODES USED ONLY FOR COMPLETE OPENING**

You can only delete the codes if the gate is closed.

- 1 - Position DIP 1 to ON and then DIP 3 to ON.
- 2 - The red programming DL1 LED will flash ON and OFF, one second on each, for 10 seconds.
- 3 - Press and hold the PROG button for 5 seconds. The green DL2 LED will flash twice to confirm that the stored codes have been deleted.
- 4 - The red programming DL1 LED remains active and you can programme new codes as shown above if required.
- 5 - Reposition DIP 1 to OFF and DIP 3 to OFF.
- 6 - You have completed the procedure.

#### HOW TO CHECK IF THE MEMORY IS FULL FOR RADIO CODES USED ONLY FOR COMPLETE OPENING

You can only check the memory if the gate is closed.

- 1 - Position DIP 1 to ON and then DIP 3 to ON.
- 2 - The green DL2 LED will flash 6 times if the memory is full (30 codes have been stored).
- 3 - After this, the DL1 programming LED will remain active for 10 seconds, so that you can delete all codes if required.
- 4 - Reposition DIP 1 to OFF and DIP 3 to OFF.
- 5 - You have completed the procedure.

#### FUNCTIONING OF CONTROL ACCESSORIES

**ATTENTION: ONLY IMPULSIVE COMMANDS HAVE TO BE CONNECTED.**  
**Make sure that any other type of command accessories (e.g. mass detectors) used on the installation are set in the IMPULSIVE mode, otherwise, the gate will be operated even without the protection of the safety devices.**

#### STEP BY STEP or AUTOMATIC commands

##### (K BUTT button, PED BUTT button, RADIO REMOTE button)

**DIP 6 - ON** The K BUTT, the PED BUTT button, the RADIO REMOTE buttons perform the cyclic command open-stop-close-open-stop-etc.

**DIP 6 - OFF** The K BUTT, the PED BUTT button, the RADIO REMOTE buttons perform:

- the open command, if pressed with the gate completely closed
- the close command, if pressed with the gate completely opened
- no effect, if pressed during the gate opening
- the gate re-open, if pressed while the gate is closing

The K BUTT opens the gate completely, whereas the PED BUTT opens the gate partially as described in Point D.

#### CLOCK FUNCTION

**If you want the Clock Function must request K with firmware 12 NOUP.**  
**ATTENTION: A CLOCK CONNECTED TO K with fw 05 or more ACTIVATES THE AUTOMATIC MOVEMENT OF THE GATE WITHOUT HAVING THE PROTECTION OF THE SAFETY DEVICES!**

The Clock Function is useful during rush hours, when traffic is heavy and the flow is slow (e.g. entrance/exit of employees, emergencies in residential areas or car parks and, temporarily, for removal vans) and it's necessary to keep the gate opened.

#### CLOCK FUNCTION APPLICATION

**It is necessary to request a K control panel with firmware 12 NOUP.**

Select the automatic functioning **DIP 6 OFF**.

It can be done by connecting a switch and/or a daily/weekly clock either in parallel to the K BUTT button or instead of the K BUTT button. When the control board receives this command, the gate will open and by keeping this contact closed for all the time of the gate opening, the Clock Function is automatically activated. In fact, once reached the open position, the gate will remain opened and all of the control board functions are blocked. Only when K BUTT contact is released, the control board functions are re-activated and the Automatic Closing restarts (if enabled) doing the countdown to the gate closing.

#### PEDESTRIAN command (PED BUTT - COM)

This command is useful to open the gate partially, just enough, for example, to permit a pedestrian crossing. In fact, the Pedestrian command (see Point E) is carried out only by opening the gate just enough for a pedestrian to pass, as described into the Point E procedure.

From the Pedestrian opening position the Automatic Closing can be enabled or disabled with DIP3. From the Pedestrian opening position, the gate can be completely opened by the OPEN or by the K BUTT button or by the RADIO button.

#### AUTOMATIC CLOSING (from the COMPLETE open position)

The Automatic Closing from the complete open position can be enabled turning ON the DIP3. The maximum gap of time that can be programmed is 5 minutes (see Point D).

#### AUTOMATIC CLOSING (from the PEDESTRIAN open position)

The Automatic Closing from the pedestrian open position can be enabled turning ON the DIP3. The maximum gap of time that can be programmed is 5 minutes (see Point E).

#### FUNCTIONING OF SAFETY ACCESSORIES

##### PHOTOCELL (PHOT - COM)

In case the switch DIP4 is in the OFF position, the photocells are active both in gate opening and in gate closing. In this configuration, if an obstacle cuts the photocell beam:

- while the gate is closing, the gate will open
  - while the gate is opening, the gate will stop and will restart opening when the obstacle is removed
  - while the gate is still, it will not move neither in opening nor in closing.
- In case of the switch DIP4 is in the ON position, the photocells are active only in gate closing. In this configuration, if an obstacle cuts the photocell beam:
- while the gate is closing, the gate will open
  - while the gate is opening, the gate will continue open
  - while the gate is still, it will open if a open command is request, it will remain still if a close command is request.

The photocell input (PHOT - COM) is a NORMALLY CLOSED contact.

In case there are more couple of photocells, the contacts from all the photocell receivers must be connected in series.

In case the photocells are not installed, this contact must be short circuited with a wire jump (from PHOT to COM) to permit the gate to operate.

##### SAFETY STRIP (EDGE - COM)

If it intervenes during opening, it inverts the movement and closes for 2 seconds and then stops.

If it intervenes during closing, it inverts the movement and opens for 2 seconds and then stops.

If the safety strip remains engaged (NO contact), no automatic movement is allowed.

In case the safety strip is not installed, this contact must be short circuited with a wire jump (from EDGE to COM) to permit the gate to operate.

**PAY ATTENTION:** it is highly recommended to check safety-strips operation at least every 6 months.

##### SAFETY STRIP ALARM

After the inversion given by the intervention of the safety edge, the gate stops in alarm mode and this is signaled by the blinker on for 1 minute and by the buzzer on for 5 minutes.

During or after the minute of alarm, the normal gate operations can be restored by pressing any push button.

##### TESTING THE SAFETY STRIP equipment

The DIP10 ON enables to test the safety strip equipment. The test is performed every time the gate completes a full opening. The test is available only if the safety strip device is equipped with a dedicated power supply input.

In fact, the safety strip equipment power supply input can be connected to the A+TEST and A- outputs (DIP10 ON). Automatically, every time the gate completes a full opening, just before closing, the control board switches OFF the A+TEST and A- power supply output for a very short time. While the safety strip power supply is switched OFF, if everything is working fine the safety strip contact (EDGE - COM) must open. In case the test fails, no other gate manoeuvre will be allowed and the alarm state will be signalled by both the Blinker and the Buzzer, if installed, which will remain on for 5 minutes.

**NOT ALL THE SAFETY STRIPS CAN BE TESTED, THUS THE SWITCH DIP10 MUST BE LEFT OFF.**

##### STOP BUTTON

If the Automatic command is enabled (DIP 6 OFF), a Normally Closed contact could be connected in series to the COM wire of the opened and the closed limit switches.

This contact works like a STOP button to interrupt any gate manoeuvre.

##### FUNCTIONING IN DEAD MAN MODE WHEN THE SAFETY DEVICES ARE FAILING

If the safety edge fails or remains engaged for more than 5 seconds, or if photocell fails or remain engaged for more than 60 seconds, the K BUTT and PEDESTRIAN commands will work only in dead man mode.

The signal that this mode has been activated is given by the blinking of the programming led. With the blinking of the programming led, the opening and closing operation are allowed only with the command button pressed and held. The radio commands and that of automatic closing, will be excluded, since their use in this mode, is not allowed by the norms.

Once the failing safety device is repaired, in automatic after 1 second, all standard



commands that were selected, such as step by step, automatic mode, radio commands and automatic closing start functioning again.

**Note 1:** during this functioning in dead man mode, in case of damage to the safety strips (or photocells) the photocells (or safety strips) still work by interrupting the operation in progress.

**The dead-man operation is only an emergency operation which must be activated for a very short period and with the complete installation at sight so to have a secure and safe control of the system. As soon as possible however, the failing safety devices must be repaired and activated.**

**FLASHING LIGHT**

Connect the flashing light to J7 flashing light outputs, use flashing lights ACG7059 and bulbs of 40W maximum.

**NB:** This electronic K board can only supply power to FLASHING LIGHTS with inbuilt flashing circuit.

**PRE-FLASHING function**

The DIP 5 in the ON position enables the pre-flashing, the FLASHING LIGHT and BUZZER starts working 3 seconds before every movement of the gate.

The DIP 5 in the OFF position disables any pre-flashing, the FLASHING LIGHT, the BUZZER and the motor will start at the same time.

**BUZZER (COM.+ BUZZER-)**

The current supplied to the Buzzer will be 200 mA at 24Vdc.

During the normal operation of the gate, opening and closing, the buzzer will buzz intermittently. Only during the alarm situations (safety strip) the buzzing will almost be constant.

**GATE OPEN INDICATOR (A negativo - LSC)**

It is turned ON when the gate is open or partially open, it is turned OFF only when the gate is completely closed.

**N.B.:** connect in series to the indicator a resistance of 2K2. WE RECOMMEND NOT TO OVERLOAD THE INDICATORS OUTPUT OTHERWISE THE GATE FUNCTIONING COULD BE COMPROMISED OR THE CONTROL BOARD COULD BE DAMAGED.

**TECHNICAL SPECIFICATIONS**

Humidity	< 95% without condensation
Power supply voltage	230V~ ±10% (120V/60Hz upon request)
Frequency	50/60 Hz
Interruptions in electricity supply	20ms

Maximum load of motor outputs	1CV
Maximum load of blinker output with resistive load	40W
Maximum control board absorption (without accessories)	33 mA
Current available for photocells and accessories	0,4A±15% 24Vdc
IP protection grade	IP54
Control board weight	0,55 kg
Dimensions	130 x 50 x 115 mm

**TECHNICAL RADIO SPECIFICATIONS (model CRX)**

Reception frequency	433,92MHz
Impedance	52Ω
Sensitivity	>2,24μV
Time of excitation	300ms
Time of discharge	300ms
Memory available	60 codes (30 for complete opening and 30 for pedestrian opening)

Maximum load of radio receiver output 200mA 24Vdc  
 - All inputs shall be used as clean contacts without earthing, because the power supply is generated in the card and is structured in such a way to guarantee the respect of double and reinforced insulation to the elements under voltage  
 - All inputs are managed by a programmed circuit that carries out a self-control every time the gate is operated.

**TROUBLESHOOTING**

After having carried out all connections, by carefully following the layout and having positioned the gate in intermediate position, check the correct ignition of LEDS DL3, DL4, DL7, DL8.

In case of no ignition of the LEDS, always with gate in intermediate position, check the following and replace any faulty components.

DL3	switched off	Faulty opening limit switch
DL4	switched off	Faulty closing limit switch
DL7	switched off	Faulty photocells
DL8	switched off	Faulty safety edge (In case the edge is not connected, carry out jumper between COM and EDGE)

During functioning with personnel present, with DIP 1 at ON, check that during opening the green DL6 LED switches on and that during closing the red DL5 LED switches on. If not, invert clamps V and W on the motor terminal board.

FAULT	SOLUTION
After having carried out the various connections and having supplied voltage, all the LEDS are switched off.	Check the integrity of fuses F1 and F2. In case of interrupted fuse use only of adequate value F2 = 5A F1 = 100mA.
The motor opens and closes, but it has no strength and moves slowly.	Check trimmers TORQUE and LOW-SPEED adjustment.
The gate opens but does not close after the time set.	Ensure to have set DIP 3 at ON. Button K BUTTON always inserted in automatic functioning mode (DIP 6 OFF). Replace button or switch of the selector switch. Failed edge self-test => check the connections between electronic board and edge feeder. <b>Attention:</b> if not using a feeder for edges, DIP 10 must be at OFF position.
The gate does not open or close by activating the various K and RADIO buttons.	Faulty safety edge contact. Faulty photocells contact with DIP 4 OFF. Fix or replace the relative contact.
By activating the K button the gate does not move.	Impulse K always inserted. Check and replace any buttons or micro-switches of the selector switch.
The slowing phase is not performed.	Ensure that DIP 8 is at position OFF (slowing enabled). Learn the times through procedure from DIP 2. Check trimmer LOW-SPEED adjustment.

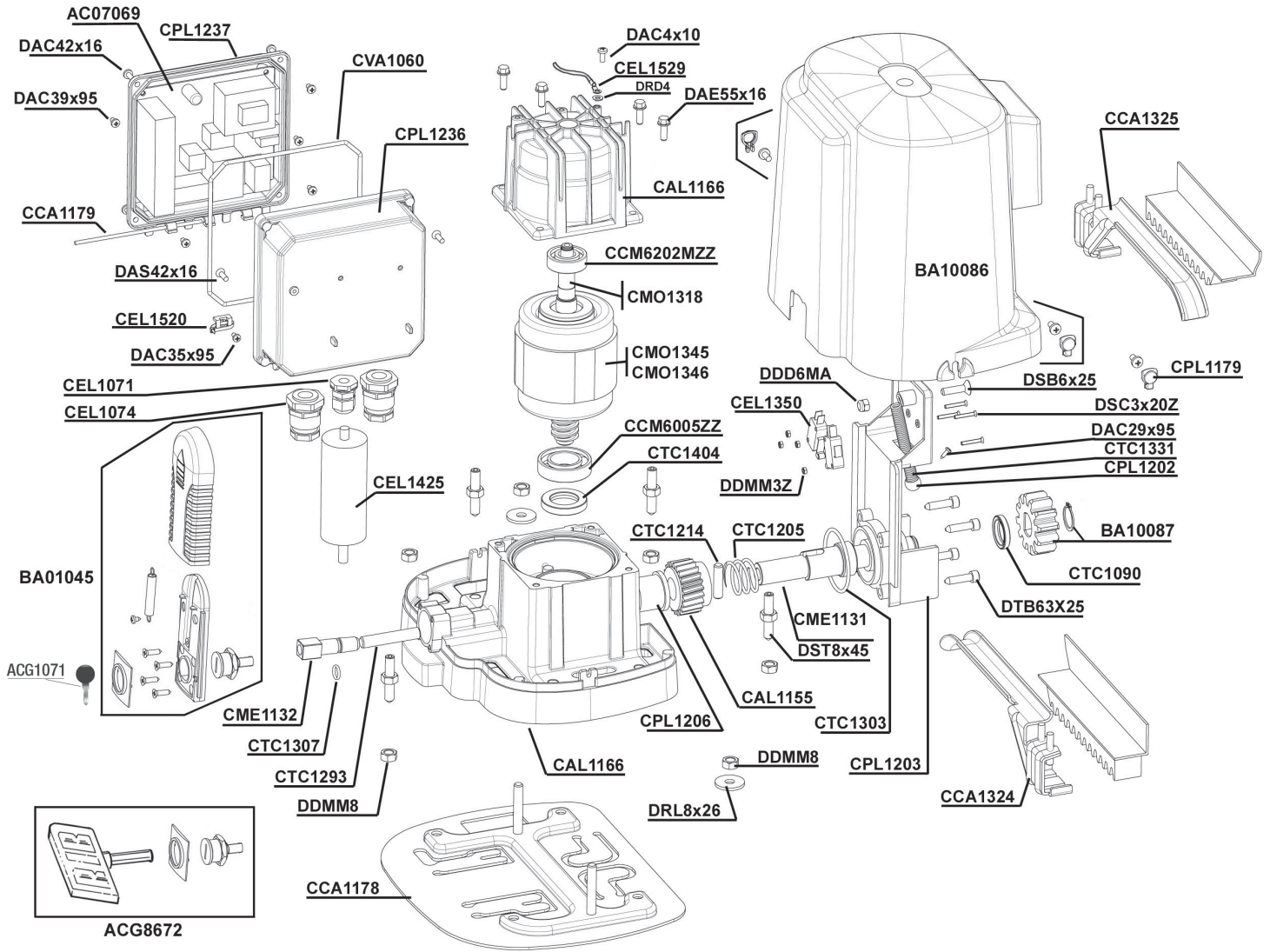

Codice	Denominazione Particolare	CEL1520	Supporto sella	CTC1404	Paraolio 25x40x7
AC07069	Scheda K 230/50-60Hz	CEL1529	Cavetto terra	CVA1060	Guarnizione K
ACG1071	Chiave di sblocco	CME1131	Albero di traino	DAC29x95	Vite aut.TC.CR. 2.9x9.5 ZINCAT
ACG8672	Serratura esagonale K/K500	CME1132	Perno sblocco	DAC39x95	Vite aut.TC.CR 3.9x9.5 DIN798
BA01045	Serie access. cilind. K500	CMO1318	Rotore con albero K500	DAC35x95	Vite aut.TC.CR 3.5x9.5
BA10086	Carter K500 completo	CMO1345	Statore K500 230/50-60 1P	DAC4X10	Vite Autom. TC CR 4x10 TRIL.UNI
BA10087	Ingranaggio traino K500	CMO1346	Statore K500 120/60 1P	DAC42x16	Vite auto. TC.CR. 4.2x16
CAL1155	Corona elicoidale	CPL1202	Sfera per molla	DAC5x10	Vite Autom. TC CR 5x10 TRIL UNI8112
CAL1166	Carcassina + campana motore K500	CPL1203	Flangia fincorsa	DAE55x16	Vite aut. TE 5.5x16 P.Tronca Z
CCA1178	Gruppo piastra base	CPL1206	Boccola	DDD6MA	Dado autob. 6MA ALTO
CCA1179	Perno cerniera scatola QE	CPL1236	Scatola QE	DDMM8	Dado 8MA medio UNI5588
CCA1324	Camme fincorsa DX	CPL1237	Coperchio scatola QE	DDMM3Z	Dado 3MA medio UNI5588
CCA1325	Camme fincorsa SX	CTC1090	Paraolio 20x30x5	DRD4	Rond. dent. D=4 piano DIN6798
CCM6005ZZ	Cuscinetto motore 6005ZZ	CTC1331	Molla fincorsa Inox	DRL8x26	Rond. piana 8.5x26x2.5
CCM6202ZZ	Cuscinetto motore 6202 ZZ	CTC1205	Molla per sblocco	DSB6x25	Vite TSPEI 6x25 UNI5933
CEL1071	Passacavo PG9	CTC1214	Spina CIL 8x32 non temprata	DSC3x20Z	Vite TSP.CR 3x20
CEL1074	Passacavo PG16	CTC1293	Spina CIL10x55	DST8x45	Grano M8x45 UNI5927
CEL1350	Microswitch a rotella	CTC1303	Anello di tenuta OR_158	DTB63x25	Vite TCEI 6.3x25 AUTOF.ZINC.
CEL1425	Condensatore 10µF con cavetto	CTC1307	Anello di tenuta OR2037	DTE8x40	Vite TE 8x40 UNI5739