

ENGLISH

Installation Manual

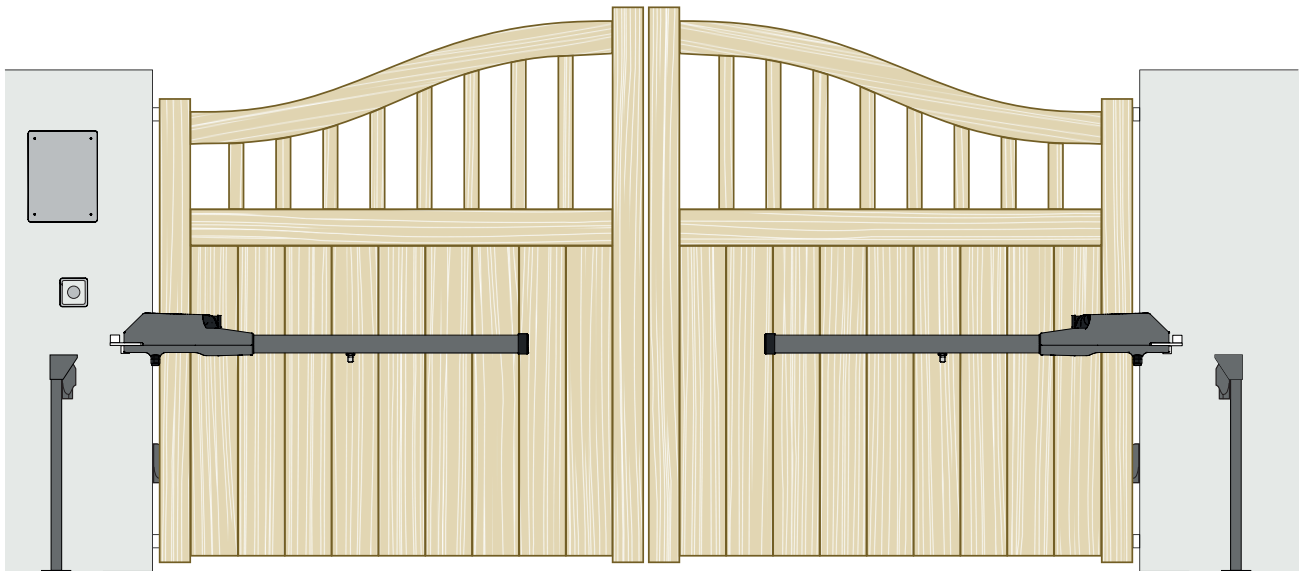

myDiamond

automation Kit for swing gates

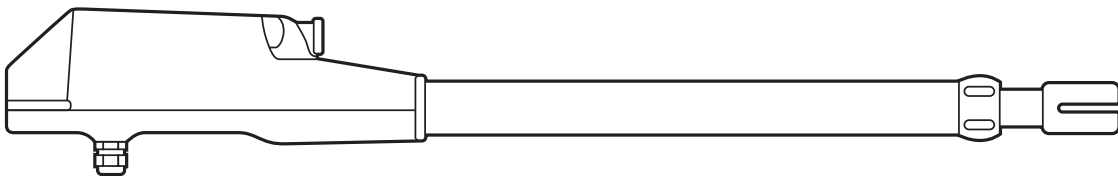

BY



GateMotors: +44 (0)1202 744958 • Technical support: +44 (0)1202 725489
www.gatemotors.co.uk • Sales and Accessories: +44 (0)1202 717191

General safety precautions

This manual contains important information for the safety of consumers. An improper installation can result in serious injury to people and/or property. Before beginning the installation it is absolutely necessary to read this manual in its entirety. Save this manual for future consultation.

Use and installation of the product must comply with Machinery Directive 2006/42/CE.

Verify that the system is EN 124445 and EN 12453 standard compliant. Installation must be carried out by qualified personnel who are aware of the associated potential hazards, and are operating in full compliance with current regulations.



PRE-INSTALLATION CHECKLIST

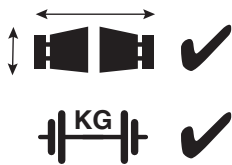

Verify that the technical features fit your installation needs.

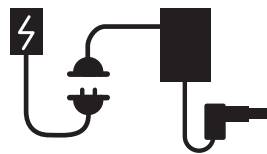

Always cut off the power during the installation or maintenance of any parts.

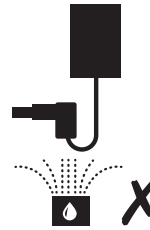

Any lawn watering devices must not wet the gate motor from the bottom up.

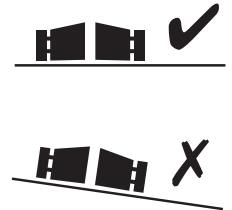

The gates are NOT on either an upward or downward slope.

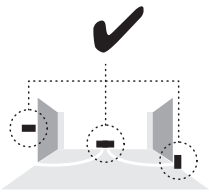

The gate has mechanical stops in both the open and closed positions.

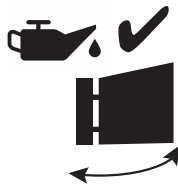

The gate hinges are in good condition and are suitably lubricated.



The gate leafs swing freely and are clear of obstruction

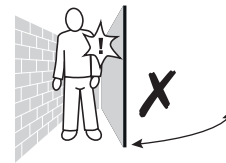

The opening of the automated gate is not an entrapment hazard with regards to any surrounding fixed parts.

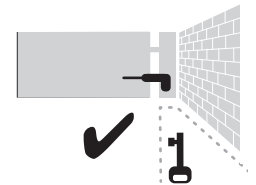

There is sufficient space for manual release.

Intended use and application

The myDiamond motor is designed to automate swing gates. The use of this product for purposes other than those described above and installation executed in a manner other than instructed in this technical manual are prohibited.

All myDiamond systems are irreversible, therefore an electric lock is not essential – but an electric lock is recommended for additional security, or for use in areas exposed to high-winds. The electric lock must be installed on the gate leaf that opens first and must be connected with the terminals of the control unit.

If fitting an electric lock, remove all manual locks and bolts.

In the event of a power cut the gate motor can be released by manual operation.

Use of the product must be restricted to its intended use. Any other use is to be considered dangerous and therefore forbidden.

Do not allow children to play with the fixed command devices, or in the gate's area of operation. Keep any remote control devices (i.e. transmitters) away from children.

Keep the gate and the gate opener regularly maintained. Use only myGate or GateMotors supplied spare parts.

Users are strictly forbidden to carry out any changes on the gate motor.







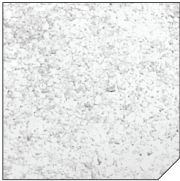
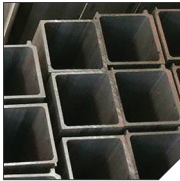
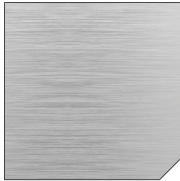
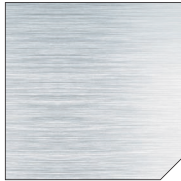

GateMotors is not liable for any damage resulting from improper, wrongful or unreasonable use.

The use of this equipment must observe the safety standards in force in the country where it is installed, as well as the standards governing proper installation.

Tools and fixings

RECOMMENDED FIXINGS

(not included)

Brick	Concrete	Metal pillar	Steel	Steel / Aluminium	Wood
					
					
Screw and wall plug	Concrete anchor	Nut and bolt	Lock nut	Nut and bolt	Wood screw

REQUIRED TOOLS

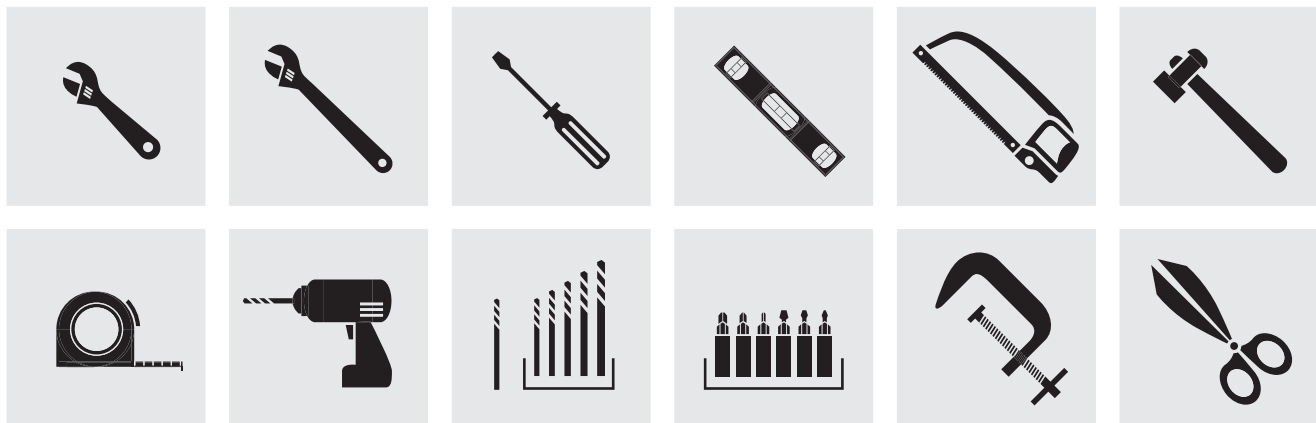

myDiamond dimensions

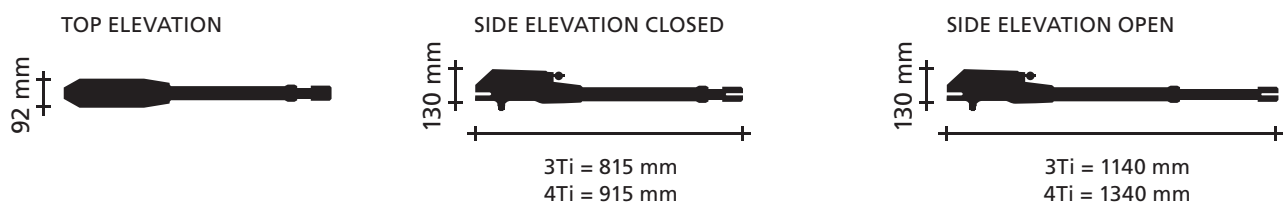

GateMotors: +44 (0)1202 744958 • Technical support: +44 (0)1202 725489
www.gatemotors.co.uk • Sales and Accessories: +44 (0)1202 717191



Technical features

	myDiamond 3Ti	myDiamond 4Ti
Power supply	230 v ~ 50 Hz	
Absorption	1.2 - 1.7 A	
Motor power	300 W	
Capacitor	10 µF	
Thermic protection	150°	
Maximum thrust	3000 N	
IP level	54	
Revolutions speed	1400 g/m	
Working temperature	-20° - +55°C	
Leaf's maximum length	2000 mm	3000 mm
Leaf's maximum weight	350 Kg	400 Kg
Standard stroke	300 mm	400 mm
Maximum opening	110°	120°
90° opening time	17"	22"
Duty cycle	40 %	

myDiamond Kit Contents (included)

- A** 2 x Motors
- B** 1 x Control Board (with in-built aerial)
- C** 2 x Wired Safety Photocells
- D** 2 x Radio Remotes
- E** 2 x Brackets S3
- F** 2 x Brackets T1
- G** 2 x Manual Release Keys
- H** 2 x Fixing pins

INWARD FACING

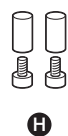
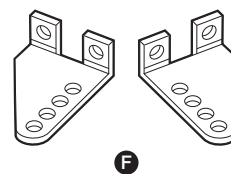
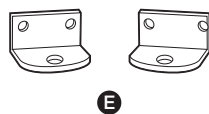
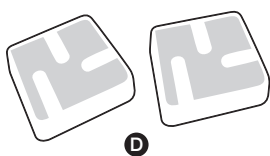
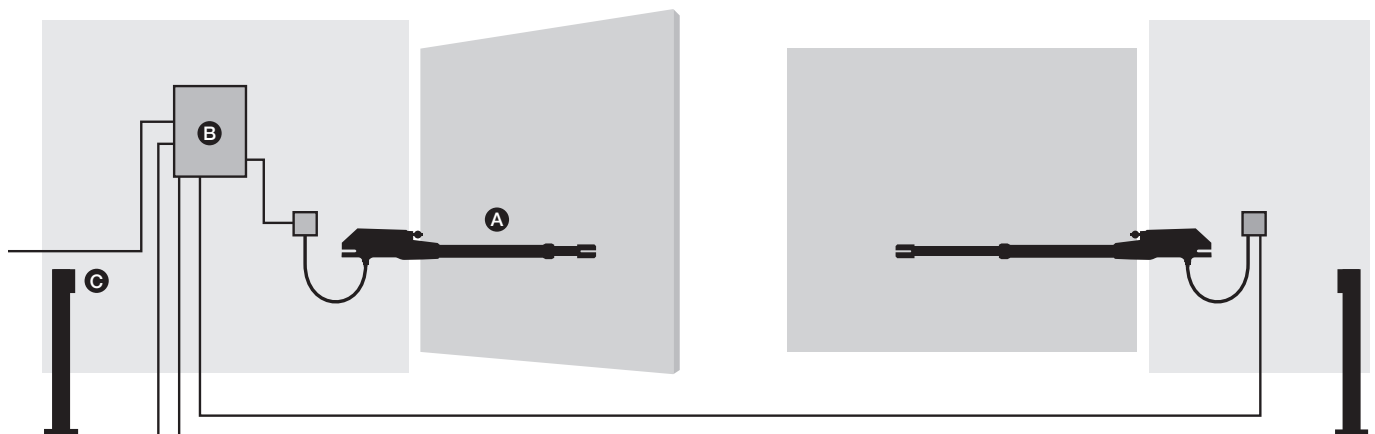

INSTALLATION INSTRUCTION SEQUENCE

- 1 Thoroughly read sections: General safety precautions, and Intended use and application.
- 2 Check all the components.
- 3 Identify the fixing points on the pillar and on the gate.
- 4 Verify measurement **D**.
- 5 Adjust bracket **T1** as needed.
- 6 Fix the motor to the bracket **T1**
- 7 Release the motor.
- 8 Fix bracket **S3** to the gate.
- 9 Fix the motor ram to the bracket **S3**.
- 10 Position the cables as per the Wiring installation overview.
- 11 Connect the control unit and all accessories.
- 12 Program the radio receiver.
- 13 Program the working times.

Installing the motor

Make sure there are mechanical stops (**B**) for opening and closing.

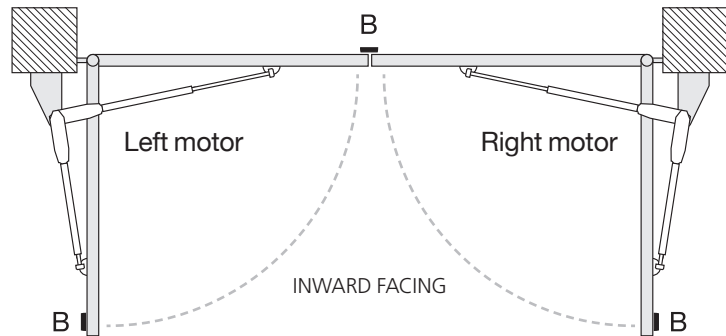

Check that the open position of the automated gate is not an entrapment hazard with regards to any surrounding buildings or fixed objects and there is sufficient space for manual release.

Motor positioning

The motor has to be fitted keeping a height above ground of between **400 mm** and **500 mm**. If the gate is particularly light, fit the motor as close as possible to the gate centerline. The motor should not be fitted lower than **150 mm** from ground level. And no more than **600 mm** higher than ground level.

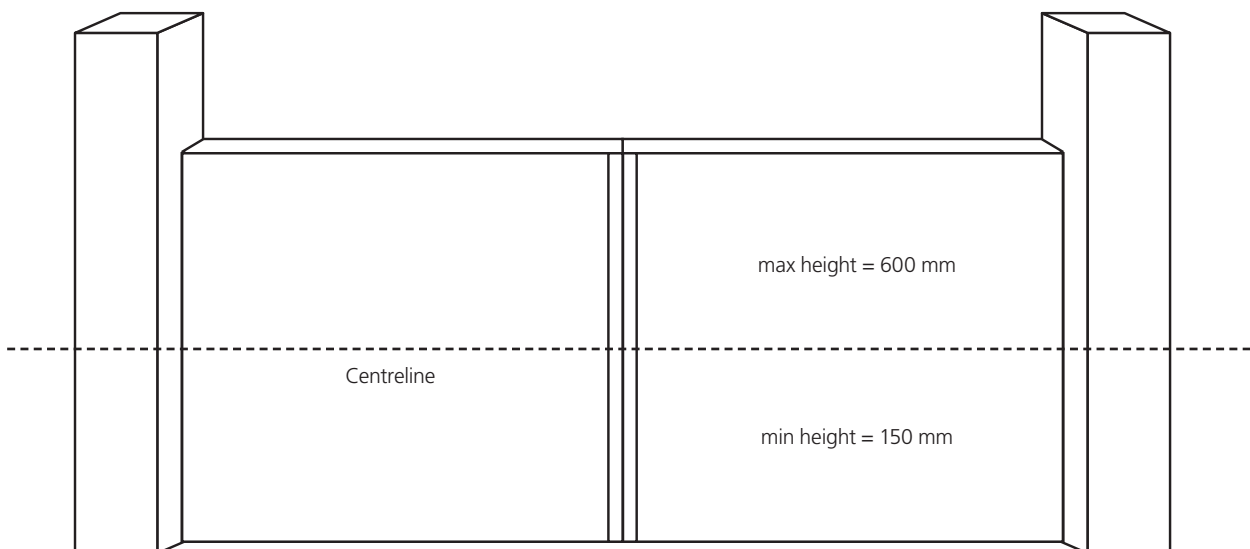

Pillar bracket T1

How to determine fixing dimensions

Position the bracket **T1** using the measurement **A** and **B** as indicated in the below table for an inward opening angle of **90°** (pic E).

	myDiamond 3Ti	myDiamond 4Ti
A	150 mm	200 mm
B	150 mm	200 mm
D	100 mm (150 mm max.)	150 mm (200 mm max.)

(Table A)

(pic E)

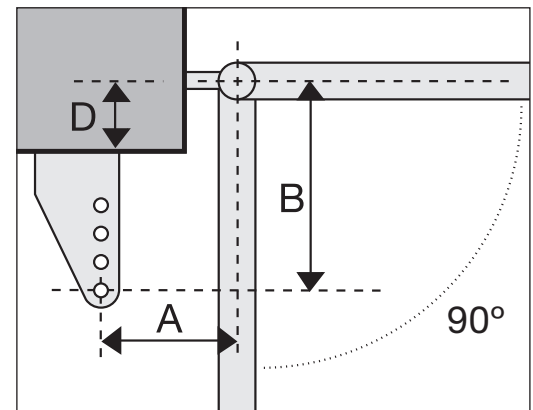

If the ideal scenario of measurements **A** and **B** (above) is unachievable then refer to the below tables to determine the position and mounting hole selection for bracket **T1**.

myDiamond 3Ti

D	150 mm	125 mm	100 mm	75 mm	50 mm	25 mm	0 mm
A	100 mm	125 mm	150 mm	145 mm	140 mm	135 mm	160 mm
B	200 mm	175 mm	150 mm	155 mm	160 mm	165 mm	140 mm
Bracket quota	50 mm	50 mm	50 mm	80 mm	110 mm	140 mm	140 mm
Minimum leaf length	880 mm	860 mm	840 mm	840 mm	850 mm	850 mm	830 mm

myDiamond 4Ti

D	200 mm	175 mm	150 mm	125 mm	100 mm	75 mm	50 mm	25 mm	0 mm
A	140 mm	170 mm	200 mm	195 mm	190 mm	185 mm	210 mm	235 mm	260 mm
B	250 mm	225 mm	200 mm	205 mm	210 mm	215 mm	190 mm	165 mm	140 mm
Bracket quota	50 mm	50 mm	50 mm	80 mm	110 mm	140 mm	140 mm	140 mm	140 mm
Minimum leaf length	1030 mm	1000 mm	980 mm	990 mm	990 mm	970 mm	970 mm	950 mm	930 mm

(pic F)

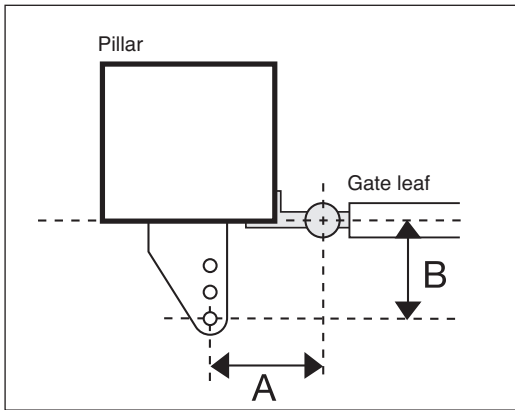

Gates fixed on the edge/corner of a pillar

In this case the gate can be opened up to **120°**. To achieve this, measurement **A** must be equal to or greater than measurement **B** (pic F).

Based on the figures shown on the previous page (Table A) – Ideally measurement **B** (Pic F) will be **decreased** by the same amount as the **A** measurement is **increased**.

For example: If installing the myDiamond 3Ti – measurement **A** increasing **20 mm** (now 165 mm) means measurement **B** ideally decreases **20 mm** (now 125 mm).

Outward opening

- In the case of an outward opening gate, the gate motor must be positioned on the inside face of the gate pillar (pic G).
- In this case the measurement **A** (distance between the axis of the hinges and the rotation axis of the motor) has to be measured towards the centre of the gate, and it is necessary to modify the bracket **T1** to adapt it to the new fixing position (pic G).
- In order to not reduce the size of the passage, the motor can be positioned in the upper part of the gate, at a height no less than **2000 mm**.
- You can find the position of the front bracket with the method indicated above, but with the leaf of the gate open.
- The preferred measurements are the same as those shown on the previous page (Table A).
- All fastenings must be strong and secure.

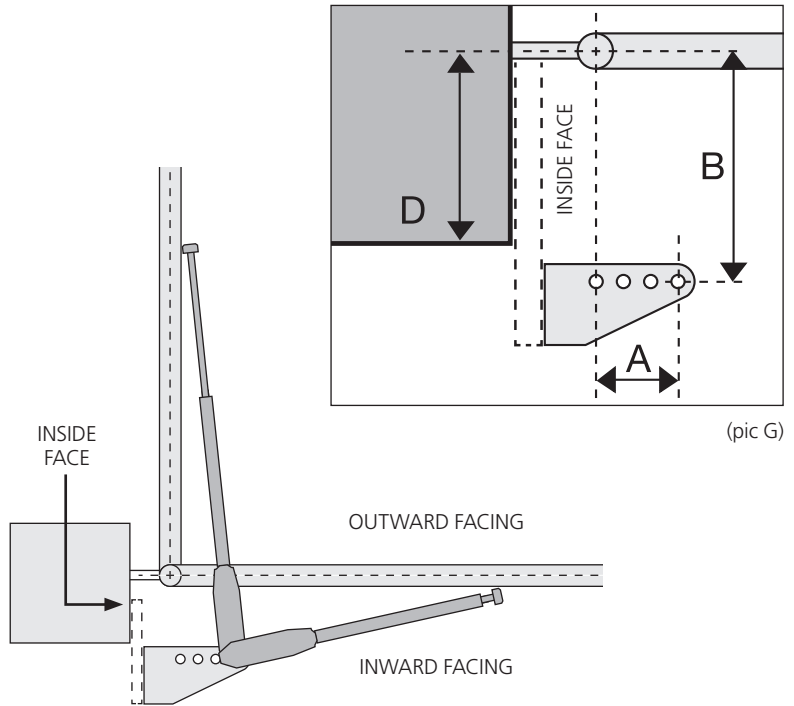

Fixing pillar bracket T1

Fix the pivot bracket **T1** onto the pillar by welding or bolting (**Ø13 mm bolts**), making sure the measurements shown in the previous table are met. Ensure to keep a minimum distance of **30 mm** from the pillar edge as shown (pic H).

In cases of masonry pillars, use chemical or resin to secure the bolts into position. Brackets **T1** are supplied in two versions, left hand and right hand and match the according motor (see picture I). Fix the motor to bracket **T1** and place the pivot pin **PR1** through the holes. Keep the pivot pin **PR1** oriented downward (pic J).

(pic H)

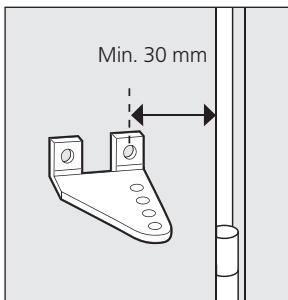

(pic I)

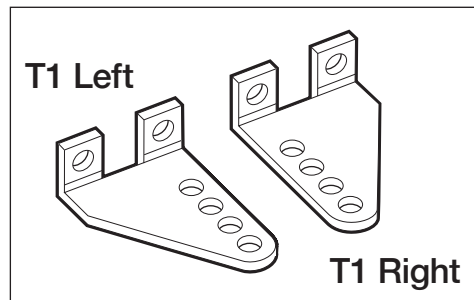

(pic J)

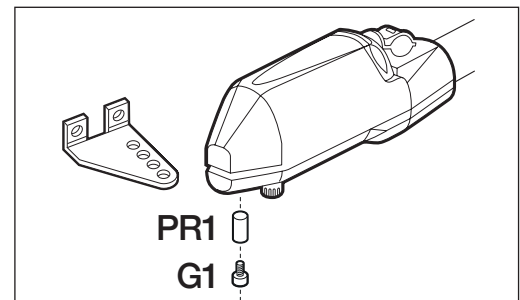

Gate brackets S3

To determine the position of bracket **S3**:

- Put the gate in the closed position.
- Manually release the motor (see below).
- Extend the ram to maximum opening.
- Push back the ram **20 mm**. This stops the motor from 'leaping forward' (pic K).
- Affix the bracket **S3** to the motor ram slot as illustrated (pic L). Place the pivot pin **PR1** into the locating hole (pic L).
- Secure the bracket **S3** to the gate leaf. Ensure the ram is perfectly straight. Use a spirit level for accuracy.

(pic K)

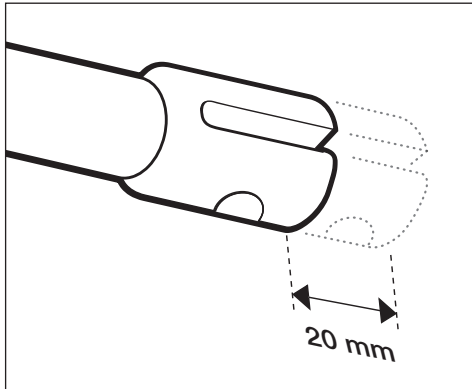

(pic L)

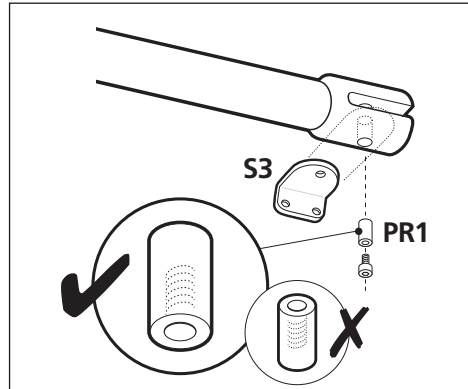

NB: Check the manual opening of the gate leaf before definitively fixing the bracket **S3** to make sure the gate can open fully to your required angle.

Manual release

- Insert the release key (included in the fixing pack) and turn **90°** (pic O).
- Turn the complete lock system **90°** (pic P)
- You will now be able to manually open and close your gate.
- If you wish to lock back your system, put the lock system back to it's original position and turn the key **90°**.
- The gates can be at in any position – since after the first start command the system will return to its default settings.

(pic O)

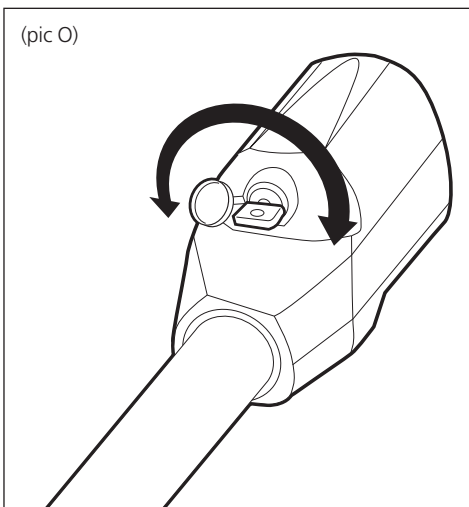

(pic P)

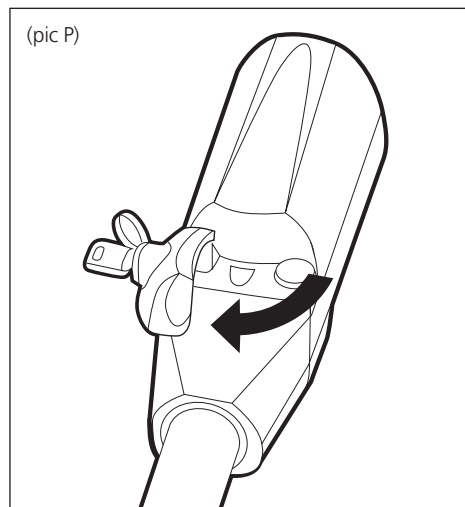

Wiring installation overview

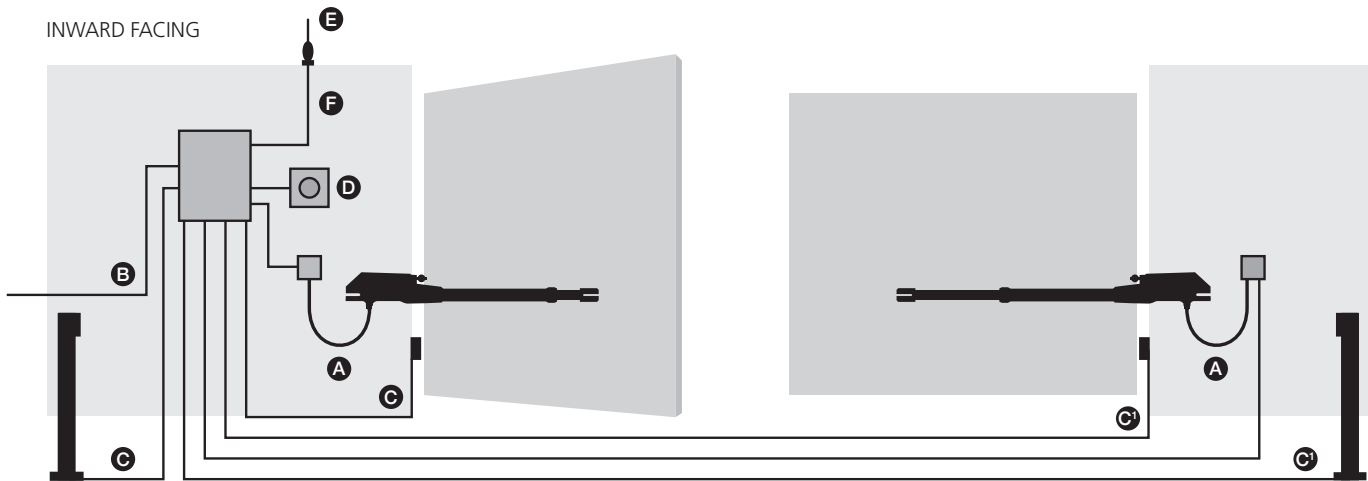

		230V
A	Motor	3 x 1,5 + T
B	Control panel	2 X 1,5 + T
C	Photocells	rx 4 x 0,50 mm ²
C'	Photocells	tx 2 x 0,50 mm ²
D	Key-switch	2 X 0,50 mm ²
E	Aerial	RG58
F	Radio receiver	2 X 0,50 mm ²



- Cut off the power before starting the wiring.
- See the control panel instruction manual (separate documentation) and refer to the Control Board section for guidance.
- A circuit breaker should be fitted close to the gate (**3 mm** wires) to protect both the gate control panel and the property's main fuse box. A **6 A** automatic breaker or a **16 A** single phase breaker complete with fuses shall be suitable.
- Make sure you have suitable tubing and conduits for the electrical cables: feed the motors, control panel and accessories separately, in order to prevent interferences that may result in bad operation.
- Fit the power cable keeping a curve as shown (pic Q) in order to avoid water backflow inside the motor.
- The power supply lines – to the motors, to the control unit and to the accessories, must be separated to avoid interferences which could generate problems to the system.
- Any equipment (either of control or safety) connected to the control unit must be tension free.

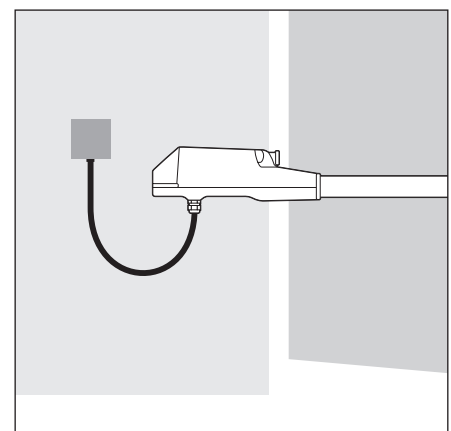

(pic Q)

Maintenance



Periodic maintenance is needed. We suggest checking the state of lubrication and tightness of the anchoring screws on the motor as well as the good operation of all safety devices and accessories.

Warranty

GateMotors warrants to you that the supplied goods will be free from defects in workmanship and materials under normal use for a period of 3 years on mechanical and 1 year on electrical parts from the date the goods were invoiced.

Any form of warranty provided here is strictly conditional upon compliance with the instructions for use and maintenance. The Installation and any maintenance works are the responsibility of who installs the system.

The warranty is on a 'return to base' basis. This means goods must be returned to us for testing before any further action can be taken.

If a defect arises and a valid claim is received by GateMotors within the warranty period, the goods should be returned as per instructions below. Shipping costs will be paid by the customer in the first instance. If the goods are deemed faulty then shipping costs will be reimbursed upon proof of purchase.

All goods returned to us for repair or warranty claim will be inspected and repaired/replaced as necessary.

GateMotors will not be liable for costs incurred relating to removal or re-installation of goods found to have a manufacturing defect.

The limited warranty does not apply in the event of:

- Opening or repair by someone not authorised by GateMotors.
- Repair or replacement of any goods or part thereof damaged by: misuse, moisture, liquids, proximity or exposure to heat, abuse, non-compliance with the installation and/or usage instructions supplied with the goods, neglect or misapplication.
- Any disfigurement / removal / tampering of any labels attached to the product will invalidate the warranty.
- Transferring the warranty to any other person. The warranty is only applicable to the original purchaser.

Under no circumstances and in no way will GateMotors be liable for damages, including any loss of profits, savings, or other incidental or consequential damages, resulting from the use or inability to use the myGate products.

The limited warranty does not affect any legal rights under the national legislation governing the Consumer Rights Act 2015.

Warranty Repair Guide

- 1** You will be required to prove that you purchased the items directly from us. Please have your invoice to hand so we can trace your transaction.
- 2** Contact technical support: 01202 725489
If our experts are unable to resolve your problem proceed to Step 03.
- 3** Complete the Customer Returns Request Form: www.gatemotors.co.uk/returns/
- 4** On completion of the form you will be issued with an SRN number.
- 5** Return the item with the SRN clearly marked on the outside of the box. The SRN will expire after 21 days and the return will be closed.

- In the event of no fault found a £30 +VAT charge will be incurred and the item/s will not be returned to you until receipt of payment. Delivery costs will also be applicable.
- All items returned that are outside the limited warranty will incur a testing fee of £30 +VAT before a quotation is provided for potential repairs.

Phasing out and disposal



Please dispose of responsibly.

Some components may contain hazardous waste. They should be removed and processed by a licensed company. Before acting always check the local laws on the matter.

EU DECLARATION OF CONFORMITY

myGate is a trademark of Proteco S.r.l.

declares that:

THE PRODUCT TYPE : DIAMOND automation Kit for swing gates

Models: DIAMOND 3, DIAMOND 4, DIAMOND24 3, DIAMOND24 4, DIAMOND 3 115, DIAMOND 4 115.

are built to be integrated into a machine or to be assembled with other machinery to create a machine under provisions of 2006/42/EC Machinery Directive.

It complies with the essential requirements of EU Directives:

2014/30/UE (EMC)

RoHS2 2011/65/CE

2014/35/UE (LVD)

2014/53/UE (RED)

The product also complies, for the applicable parts, to the following directives and standards:

EN12453, EN12604

EN55014-1, EN55014-2, EN61000-6-1, EN61000-6-3

EN 60335-1, EN 60335-2-103, EN 60335-2-95

The manufacturer declares that the commissioning of the machinery is not permitted until the machine, which this product is incorporated into, has been identified and declared conformant to the 2006/42/EC Machinery directive.

May 27h 2019

Marco Gallo
Managing Director



This compliance declaration combines the content of separate compliance declarations for any product mentioned; a copy of the original compliance declaration of each product can be obtained from PROTECO Sri.

GateMotors: +44 (0)1202 744958 • Technical support: +44 (0)1202 725489
www.gatemotors.co.uk • Sales and Accessories: +44 (0)1202 717191





Screwjack Ltd T/A GateMotors

Pre-Sales Support: +44 (0)1202 717191 • sales@gatemotors.co.uk

Technical Support: +44 (0)1202 725489 • support@gatemotors.co.uk

PRODUCT DETAILS

Gate kit make and model

Serial number

INSTALLER DETAILS

Company name

Installer

Telephone number

Signature Date

COMMISSIONER DETAILS

Name

Signature Date



IMPORTANT: Please ensure the above is filled out at time of installation, failure to do so may invalidate a warranty claim