

Powermaster Model RSG 2000

INSTALLATION MANUAL

CAREFULLY READ THIS ENTIRE MANUAL FIRST BEFORE PROCEEDING!

LEAVE THIS MANUAL WITH END USER FOR FUTURE REFERENCE AFTER INSTALLATION IS COMPLETE (LAST PAGE SHOULD BE FILLED OUT AND RETAINED BY INSTALLER FOR FUTURE USE)

THE FOLLOWING INFORMATION SHOULD BE RECORDED AT TIME OF INSTALLATION:

Date: _____ Serial #: _____ Wiring Diagram #: _____

THE OPERATOR SERIAL # IS LOCATED ON THE REAR INTERIOR WALL OF THE OPERATOR ENCLOSURE. THE WIRING DIAGRAM IS LOCATED IN THE LEFT INTERIOR WALL OF THE OPERATOR ENCLOSURE WITH THE DIAGRAM # AT THE LOWER RIGHT- HAND CORNER OF PAGE.

THE ABOVE INFORMATION SHOULD BE GIVEN IN ALL CORRESPONDENCE REGARDING THE OPERATOR TO INSURE FAST SERVICE WHEN ORDERING PARTS OR REQUESTING INFORMATION.

The above identified unit is rated in the following class:

- Class I- Residential Vehicular Gate Operator -A vehicular gate operator (or system) intended for use in a home of one to four single family dwellings, or a garage or parking area associated therewith.
- Class II- Commercial/General Access Vehicular Gate Operator -A vehicular gate operator (or system) intended for use in a commercial location or building such as a multifamily housing unit (five or more single family units), hotel, garages, retail store or other building servicing the general public.
- Class III- industrial/limited Access Vehicular Gate Operator -A vehicular gate operator (or system) intended for use in an industrial location or building such as a factory or loading dock area or other locations not intended to service the general public.
- Class IV Restricted Access Vehicular Gate Operator -A vehicular gate operator (or system) intended for use in a guarded industrial location or building such as an airport area or other restricted access locations not servicing the general public, in which unauthorized access is prevented via supervision by security personnel.

Attach large warning signs provided to each side of gate in the most conspicuous place. Mount control station and smaller warning placard together within sight of the gate opening.



Attach large warning signs provided to each side of gate in the most conspicuous place. Mount control station and smaller warning placard together within sight of the gate opening.

Important!!

SAFETY INSTRUCTIONS FOR SLIDE GATE OPERATING SYSTEMS SAFETY IS EVERYONE'S BUSINESS

Automatic gate operators provide convenience and security to users. However, because these machines can produce high levels of force, it is important that all gate operator system designers, installers, and end users be aware of the potential hazards associated with improperly designed, installed, or maintained systems. Keep in mind that the gate operator is a component of a total gate operating system.

The following information contains various safety precautions and warnings for the system designer, installer, and end user. These instructions provide an overview of the importance of safe design, installation, and use.

Warnings are identified with the symbol ▲. This symbol will identify some of the conditions that can result in serious injury or death. Take time to carefully read and follow these precautions and other important information provided to help ensure safe system design, installation, and use.

WARNING: Gate operators are only one part of a **total gate operating system**. It is the responsibility of the purchaser, designer, and installer to ensure that the total system is safe for its intended use. All secondary entrapment safety devices must be U/L recognized to complete the operating system.

SYSTEM DESIGNER SAFETY INSTRUCTIONS

1. ▲ Familiarize yourself with the precautions and warnings for the installer. Users are relying on your design to provide a safe installation.
2. ▲ The operator is supplied with a primary current sensing entrapment protection system. The installation must also have a secondary entrapment protection system installed, such as photoelectric sensors or an electric edge system (See page 8 & 9).
3. ▲ When designing a system that will be entered from a highway or main thoroughfare, make sure the system is placed far enough away from the road to eliminate traffic backup. Distance from the road, size of the gate, usage levels, and gate cycle/speed must be considered to eliminate potential traffic hazards.
4. ▲ The majority of injuries from slide gate operator systems occur with Open Rollers or Ornamental Grill Type Gates. The illustrations and descriptive captions found on the following pages provide precautions to help eliminate injuries or fatalities. Familiarize yourself with them when designing the total system.
5. ▲ Design gate systems so a person(s) cannot reach through the gate to operate any controls. Never place controls on the gate operator itself

INSTALLER SAFETY INSTRUCTIONS

A. Before Installation

1. ▲ Check to see that the operator is proper for this type and size of gate and its frequency of use. If you are not sure, consult factory.
2. ▲ Check to see that there are no structures adjacent to the area, which may pose a risk of entrapment when gate is opening or closing.
3. ▲ You must ensure that the gate has been properly installed and works freely in both directions. Repair or service any worn or damaged gate hardware prior to installation. A freely moving gate will require less force to operate and enhance the performance of the operator as well as the safety devices used within the system.
4. ▲ Install the gate operator on the inside of the property and/or fence line. **DO NOT** install an operator on the public side of the gate.
5. ▲ The operator is supplied with a current sensing primary entrapment protection system (See page 7). Additional safety equipment such as electric edges or photocell sensors must be installed to provide the required secondary entrapment protection system (See page 8). Severe injury or death can result from entrapment by gate. For assistance in selecting the correct type of safety equipment, consult the factory.
6. ▲ Review the operations of the unit and become familiar with the manual disconnect mechanism and safety features of the system.
7. ▲ You must install a push-button control or key switch to allow for normal operation of the gate if the automatic controls do not work. Locate the push button or key switch and small warning placard within sight of gate in a secured area at least 10 feet or more from the gate and fence to keep users away from the moving gate.
8. ▲ Outdoor or easily accessed controls should be of security type to prohibit unauthorized use.

B. During Installation

1. ▲ Be aware of all moving parts and avoid close proximity to any pinch points.
2. ▲ Disconnect power at the control panel before making any electric service connections. Connection locations for controls and safety equipment can be found on the wiring diagram, and in this manual (See pages 7 & 8)
3. ▲ Know how to operate the manual disconnect mechanism (See Fig. 7).
4. ▲ Adjust the open and close current sensors on the PC control board in each direction to the minimum force required to operate the gate smoothly (See "**PRIMARY OBSTRUCTION SENSING DEVICE**" Fig. 9). **DO NOT** increase current setting to makeup for rough spots in gate travel - **FIX THE GATE INSTEAD!**
5. ▲ Place controls at least 10 feet from the gate so that the user can see but cannot touch the gate while operating the controls.
6. ▲ Place the warning signs provided in high visibility areas on each side of the gate to alert motorists and pedestrians of automatic gate operation.

C. After Installation

1. ▲ You are responsible for ensuring that the end user understands the basic operations and safety systems of the unit, **including the location and operation of the manual disconnect.** (see Fig 7)
2. ▲ Point out that the safety instructions in brochure are the responsibility of the end user, and then **leave a copy of this brochure with the end user.**

END-USER SAFETY WARNINGS

The manufacturer of the gate operator does not know what type of gate you have, or what type of automatic system is installed on your gate. Be sure you've been fully instructed on the sequence of operation for your specific gate system(s). Keep gate properly maintained and have a qualified service person make repairs.

1. ▲ Be sure the following safety instructions are distributed to all persons authorized to use your gate.
2. ▲ KEEP GATEWAY CLEAR (Front and back) AT ALL TIMES. Your automatic gate is not for pedestrian use. No one should ever cross the path of the moving gate.
3. ▲ Do not allow children to play near your gate, or to operate the gate.
4. ▲ Do not operate your gate system unless you can see it when the gate moves.
5. ▲ Be sure a push-button or key switch has been installed for manual electric operation in the event your radio or card control does not work. Any mounted control station should be located a minimum of 10 feet from the gate so the gate cannot be reached through or touched. Any push-button located in a building should be installed within sight of the gate.
DO NOT operate any controls without watching the movement of gate.
6. ▲ If your gate has open rollers, be sure roller guards have been purchased and installed.
7. ▲ Your gate system is required to have a primary and a secondary entrapment safety system installed and maintained (See page 7 & 8).
8. ▲ If your gate closes automatically, loop detectors should be installed to detect the presence of a vehicle.
9. ▲ **DO NOT** increase current sensor adjustment to compensate for a damaged gate. The gate should always be maintained to operate manually as easily as possible to provide maximum protection.
10. ▲ Check all safety systems at least once per month for the correct force, speed, and sensitivity. Gate must reverse when hitting a rigid object, or when non-contact sensor is activated. If these functions are observed to operate improperly, discontinue use and service immediately!
11. ▲ Your operator is equipped with a pad lockable emergency disconnect for manual operation. Be sure you have a key and understand how to operate this equipment. To operate this equipment safely, you must receive detail instruction on the operation of the manual disconnect from your installing dealer. If you have not received instruction, (See Fig. 7) or contact the factory. **NEVER OPERATE THE MANUAL RELEASE WHEN THE GATE IS MOVING.**
12. ▲ You are responsible for ensuring that warning signs are installed and maintained on both sides of your gate.
13. ▲ To ensure safe operation of this equipment, you must read this safety manual and keep it for reference.

SAFETY WARNINGS FOR OPEN-ROLLER GATES AND ORNAMENTAL GRILLE-TYPE GATES

INJURIES ASSOCIATED WITH AUTOMATIC GATES CAN OCCUR WITH OPEN-ROLLER GATES AND ORNAMENTAL "GRILLE TYPE" GATES

OPEN-ROLLER GATES

Injuries occur when people get their hands caught between the top of the gate and the roller. This potential pinch point should be guarded whenever an automatic operator is installed. Enclosed tracks are available from various fence suppliers for refitting of these rollers.

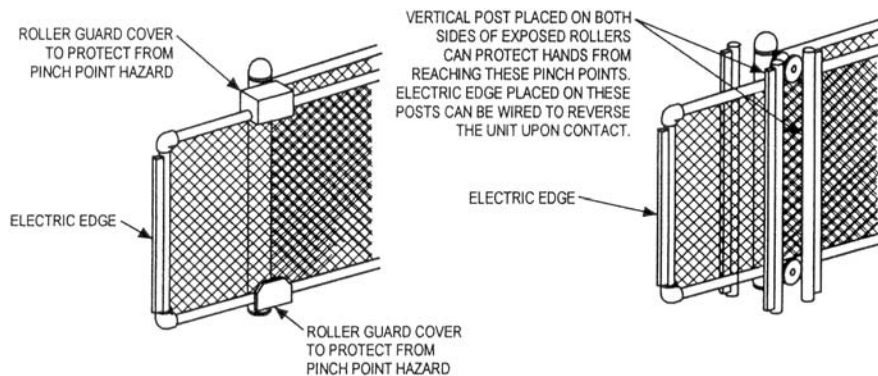

ORNAMENTAL "GRILLE TYPE" GATES.

Injuries occur when people put their arms through openings in the grilles and the gate is operated. The person cannot retract his/her arm and it gets caught between the grille and the fence post or fence. The potential hazard must be guarded. It can be simply done by placing a screen mesh on the gate and fence in the area of the gate. The screen must be a minimum of 4 feet high from the bottom (unless the gate and fence are shorter) with openings that a 2-1/4 inch sphere cannot fit through (See Illustration Below). This will help to prevent access through openings when the gate travels.

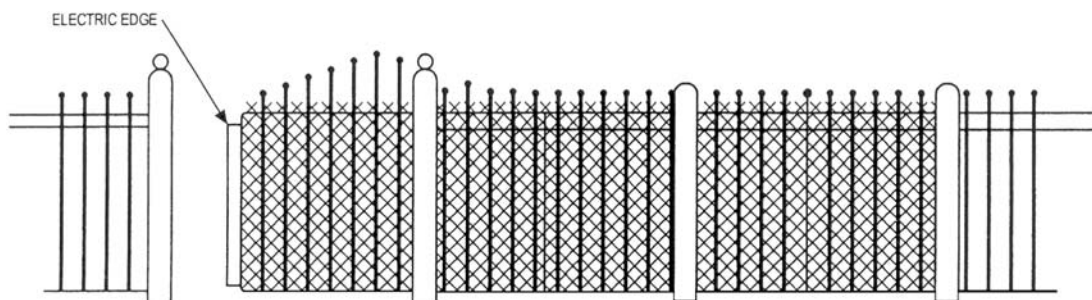

INSTALLATION INSTRUCTIONS

▲ WARNING: DO NOT APPLY POWER UNTIL TOLD TO DO SO! RISK OF ELECTRICAL SHOCK OR INJURY MAY RESULT.

IMPORTANT: BEFORE INSTALLING OPERATOR:

Gate must slide freely to fully opened and fully closed position. Gate and/or extension must extend beyond the operator location as shown in fig. 1, fig. 2, and fig. 3 (next page). Operator will be placed as shown, in fig. 1 page 7, for left and right hand installation.

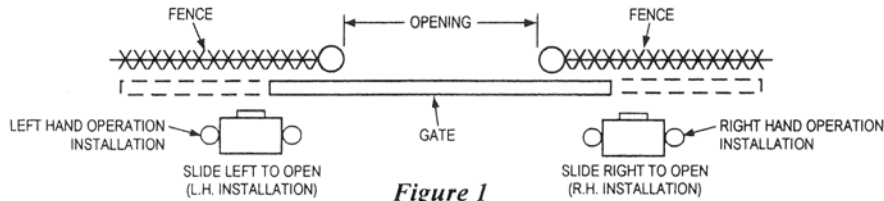

Figure 1

INSTALLATION LAYOUT:

1. Layout mounting post and electrical conduit locations (See Fig. 2 & 3).
 2. Excavate required area for conduit installation and cementing of mounting posts (minimum of 2' deep).
 3. Set mounting posts and electrical conduits in place.
 4. Pour cement to secure mounting posts and let cure for two days prior to operator installation.
- Note: Distance between mounting posts and relative location to gate is very important. Operator must be installed parallel to gate.

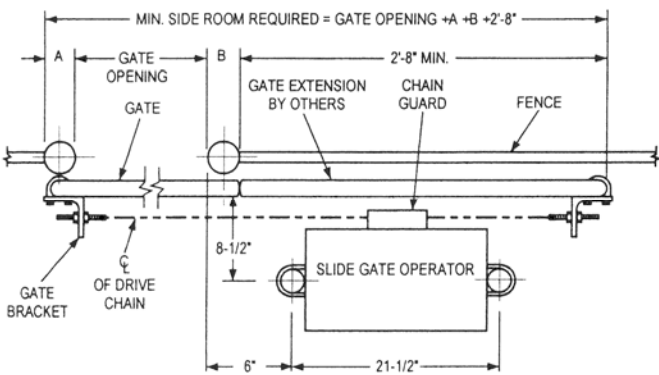

Figure 2

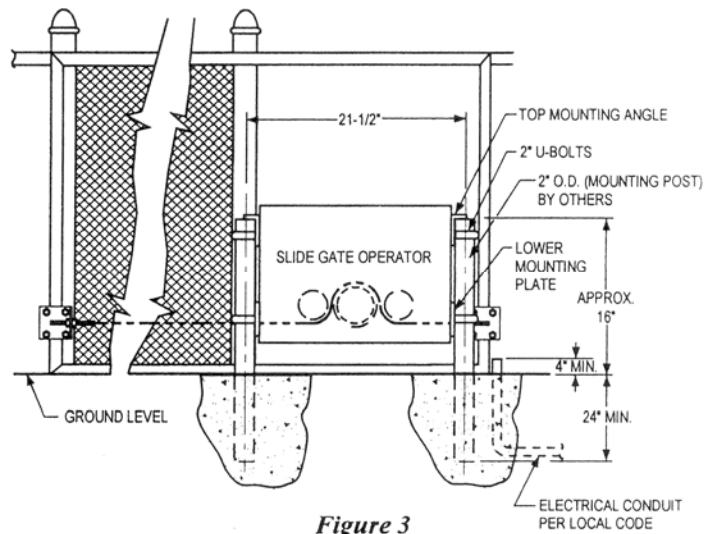
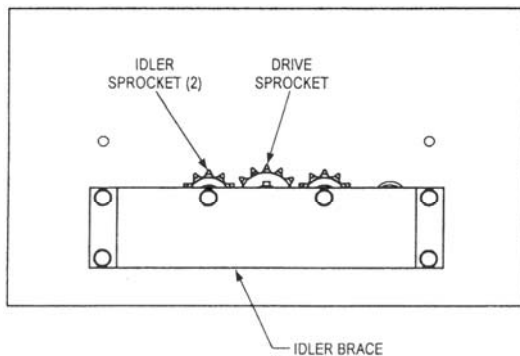

Figure 3

OPERATOR INSTALLATION:

- Note:** Remove operator top cover and chain guard for access. If gate extension is required, do so before installing operator (See Fig. 2).
- Note:** Operators are shipped from factory "slide right to open". For slide left to open, remove idler brace, turn idler brace upside down, and reinstall using upper hole pattern (See Fig. 4).



SLIDE RIGHT TO OPEN

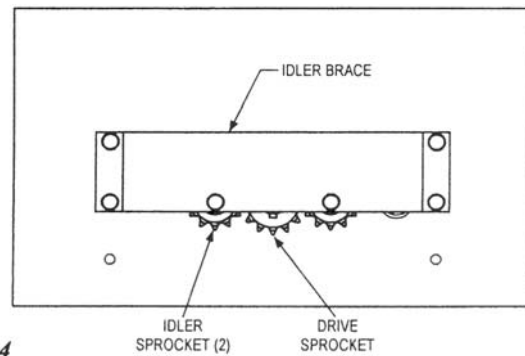

SLIDE LEFT TO OPEN

Figure 4

1. Mount operator on posts with U-bolts, mounting angles, mounting plates and hardware provided (See Fig. 3)
2. Mount (1) gate bracket at each end of gate as shown (See Fig. 2). Note: Height of gate bracket center line is to be even with the drive chain exiting operator (See Fig. 3).
3. Tighten two 3/8 inch set screws in gate bracket to prevent bracket from turning.

4. Each a chain take-up bolt to one end of drive chain, using a #41 connecting link (See Fig. 5).
 5. Insert chain take-up bolt in slot of bracket furthest away from operator. Secure location with 3/8 inch nuts, washers, and lock washers (See Fig. 5)
 6. Disengage power drive unit with manual disconnect chain (See Fig 7).
 7. Stretch drive chain out to operator and thread it around the first idler sprocket, and main drive sprocket, and second idler sprocket (See Figs 3 & 6).
 8. Pull drive chain though to opposite end of gate, cut to correct length, and secure to gate bracket, using 3/8 inch chain take-up bolt, as done in steps 4 and 5.
- Note: When pulling drive chain through operator, watch limit nuts on electric plate, to be sure they are not being mechanically driven through their normal end position.
9. Position chain take-up bolts in gate brackets, at each end of gate, so chain aligns with drive sprockets (See Fig. 2).
 10. Adjust chain tension using chain take-up bolts and outside nuts (See Fig. 5).
 11. When desired tension is achieved lock position with inside nuts (See Fig. 5).
 12. Replace chain guard.

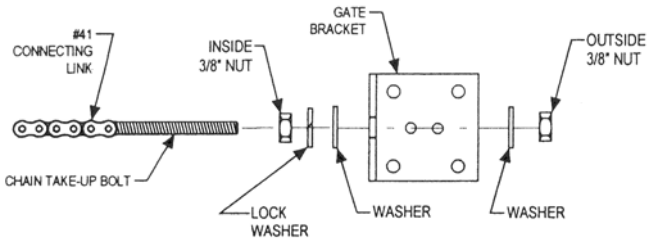
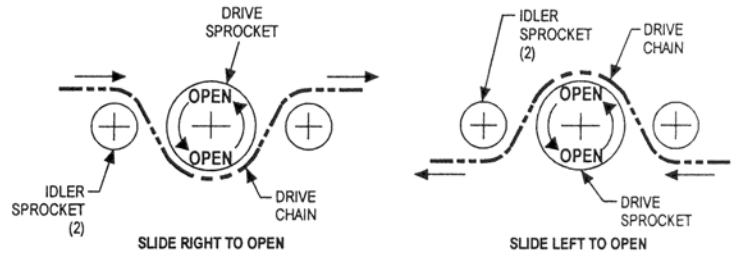
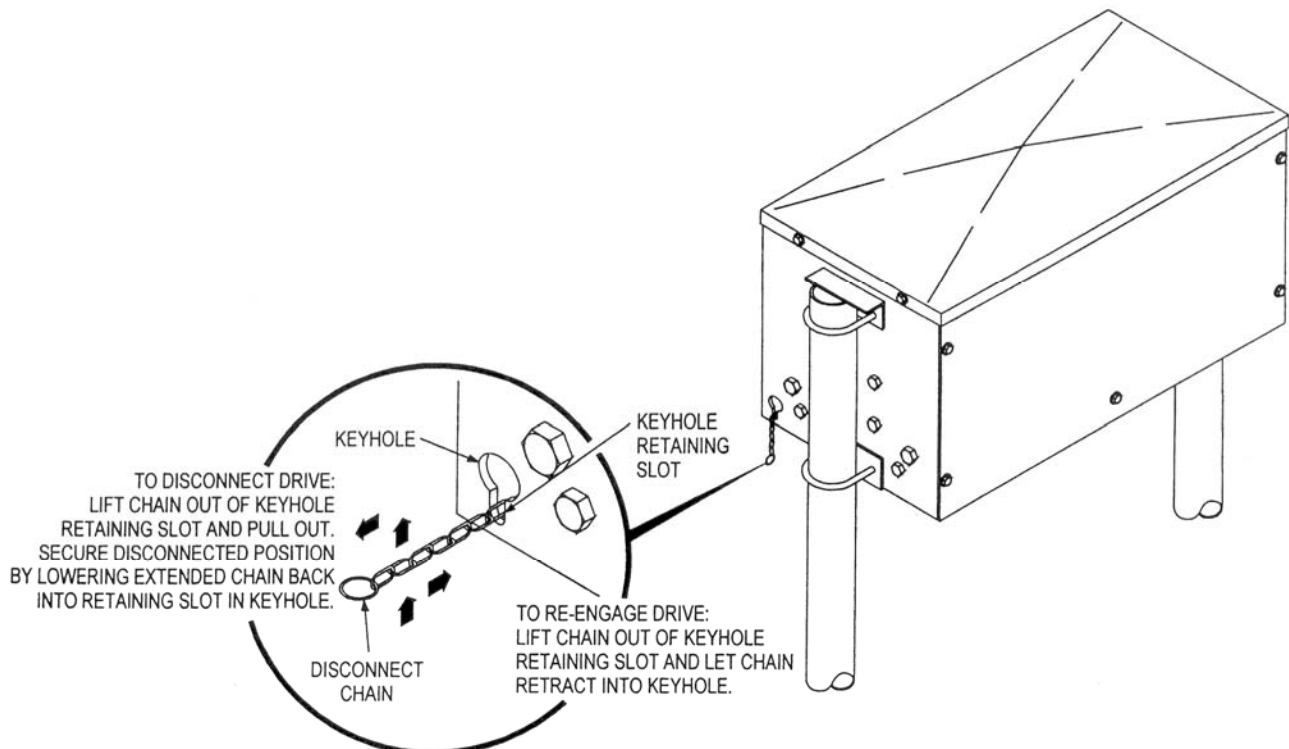

Figure 5



DRIVE CHAIN ROUTING

Figure 6



MANUAL DISCONNECT

Figure 7

**HIGH VOLTAGE
WIRE GAUGE/
DISTANCE CHART**

16 AWG	Up to 200'
14 AWG	200' to 500'
12 AWG	500' to 900'
10 AWG	900' to 1200'
Over 1200' consult the factory	

ELECTRICAL CONNECTIONS

▲ WARNING: DO NOT APPLY POWER UNTIL TOLD TO DO SO! RISK OF SHOCK OR INJURY MAY RESULT. Before connecting the operator, use a voltmeter to determine that the electrical service is 115 VAC. This operator cannot be connected to 220 volts. Damage will result, which is NOT covered by warranty.

- ▲ Be sure power switches at source and operator are OFF.
- Connect incoming power lines and ground wire as follows:
Hot leg (black) to black; Neutral (white) to white; Ground to screw.
Note: Wiring to operator must use watertight materials in accordance with local electric code.

Note: Master/Slave installation should have SEPARATE power supply wiring. If sharing a power supply line, obstruction sensing adjustments may require recalibration.

FOR MASTER/SLAVE INSTALLATION:

- Note:** A single unit is considered Master.
- Place jumper on the master operator's P.C. board in the "OFF" position (See Fig. 8).
 - Place jumper on slave operator's P.C. board in the "ON" position. (See Fig. 8).
 - Connect terminal # 15 of Master unit to terminal #5 of slave unit.
 - Connect terminal # 16 of Master unit to terminal #6 of slave unit.
 - Connect Terminal # 17 of Master unit to terminal #7 of slave unit. Note: In Master/Slave installation, one unit must be converted to LEFT HAND operation.

CONNECTION OF A THREE BUTTON STATION:

Note: All control contacts must be NORMALLY OPEN.
Connect "STOP" button to terminal #4
Connect "COMMON" button to terminal #5
Connect "OPEN" button to terminal #6
Connect "CLOSE" to terminal #7

PRIMARY OBSTRUCTION SENSING DEVICE:

Note: Gate must move smoothly and easily in manual operation before attempting this adjustment. This unit is supplied with a current sensing system which will stop gate when activated and then back the gate off approximately 2 inches and stop. If the gate is started again and the sensing system is activated a second time before hitting a limit switch, the gate will stop and sound a warning signal. A constant pressure control will then be needed to start the gate. This sensing system has adjustments located on printed circuit board (See Fig. 9). The force required to activate the system may be adjusted in both OPEN and CLOSE direction separately. Start at minimum force, and increase force until it is just over what is required to move the gate smoothly without any nuisance tripping.

NEVER INCREASE FORCE SETTING TO MAKE UP FOR A GATE THAT IS NOT MAINTAINED PROPERLY. THIS WILL DESENSITIZE THE OPERATION OF THE SAFETY SYSTEM.

**HIGH VOLTAGE WIRE GAUGE/
DISTANCE CHART**

24 AWG	Up to 150'
20 AWG	150' to 250'
18 AWG	500' to 900'

Control wiring should be run as twisted pairs. Do not run control wires in the same conduit as power wires, telephone wires or loop detectors leads

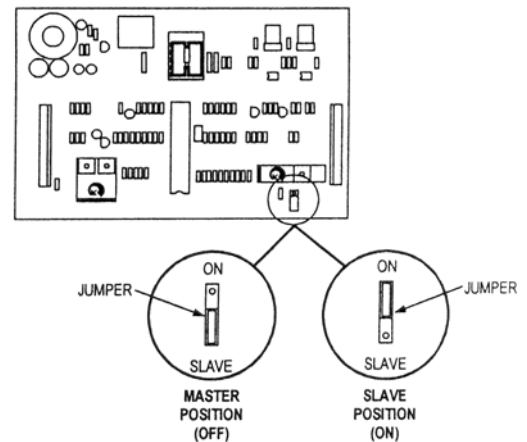

Figure 8

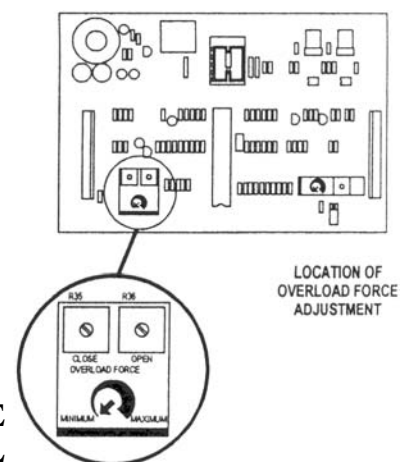

Figure 9

SECONDARY OBSTRUCTION SENSING DEVICES:

Wireless and Hardwired edges :	OPEN: connect to terminals 12 and 14 CLOSE: connect to terminals 13 and 14
Photo Eyes:	OPEN: connect to terminals 10 and 14 CLOSE: connect to terminals 11 and 14

Another sensing device (either a contact or a non-contact system) must be installed and connected to this unit to increase protection against entrapment per U/L requirements. See chart at left for terminal connections. **Note:** 24 VAC power is available between terminals #1 and #2 for devices that may require it (i.e., photo eyes, wireless edges, etc.).

Note: All control contacts must be **NORMALLY OPEN**.

CONTACT SENSOR INSTALLATION (See Fig. 10).

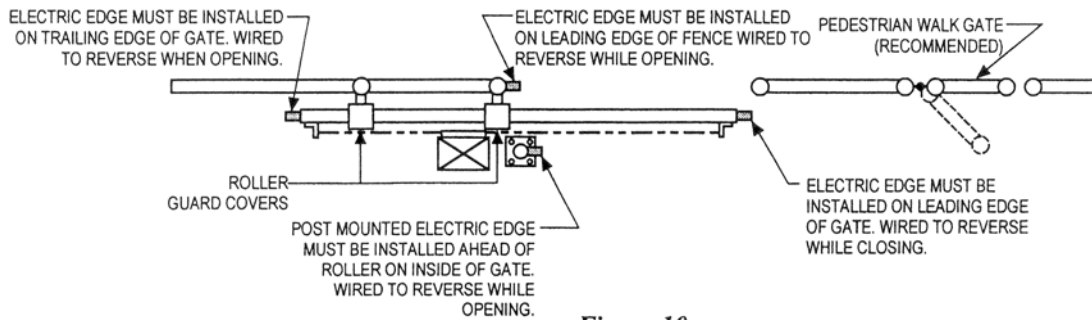

Figure 10

▲ **Note:** Wireless sensors must be installed so there is no signal interference.

▲ **Note:** All hard wiring to safety edges must be installed so there is no threat of mechanical damage to wiring between components, when gate is moving.

NON CONTACT SENSOR INSTALLATION (See Fig. 11).

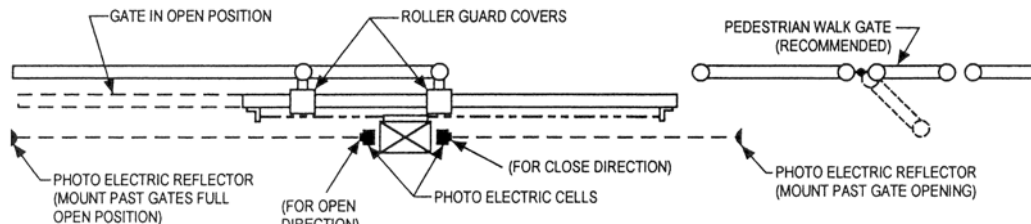

Figure 11

Note: Install photoelectric cell as close to inside of gate as possible.

Note: Photo cells should be installed across gate opening and behind gate (See Fig. 11) at least 10 inches above ground.

1. After sensors are connected, turn on power. Note: Be prepared to stop operator, if gate goes in wrong direction or passes its fully open position, in the next step.
2. Momentarily press "OPEN" button. Gate should start opening, and stop when the open limit switch is activated. This will verify that the operator motor is running in the proper direction.
3. If motor is running in wrong direction, turn off electric power at the source and contact your operator supplier. If operator is functioning correctly, test the secondary obstruction sensing system for proper operation.

RADIO CONTROL INSTALLATION:

Either a three wire or a four wire radio control receiver can be installed on this operator (See Fig. 12) for electrical connections. This radio control can only be used to open the gate, therefore the "TIMER TO CLOSE" option must be activated for closing. (See Next Section). Note: If your radio's connecting wires are not color coded as shown in figure 12 see the radio's installation manual to determine which wires are for the normally open contacts and which require the 24 VAC power supply.

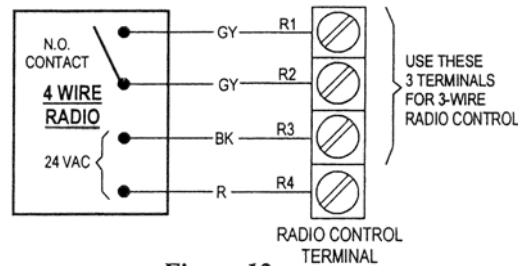

Figure 12

TIMER TO CLOSE:

The operator is equipped with a timer to close option for use with OPEN ONLY control devices such as a radio control, or a card key control. The adjustment is located on the printed circuit board (See Fig. 13). The operator is shipped from the factor with this timer preset to the OFF position; fully counter clockwise. As the timer adjustment screw is rotated clockwise, the closing of the gate can be delayed from 2 seconds to 60 seconds (See Fig. 13).

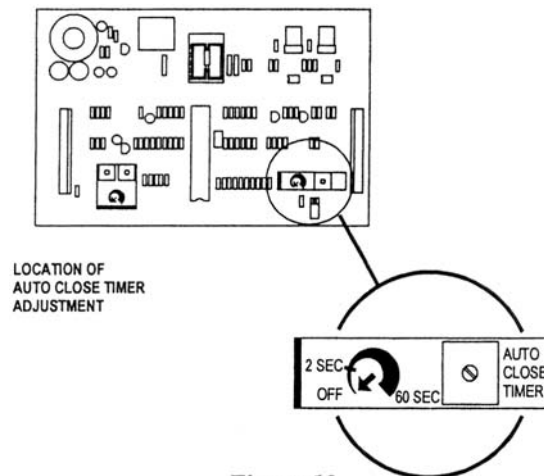

Figure 13

LIMIT ADJUSTMENT PROCEDURE:

▲ WARNING: TURN OFF MAIN POWER BEFORE MAKING ANY ADJUSTMENTS!

1. After gate is mechanically installed and controls are connected, set gate in midway position, using the manual disconnect.
2. Depress pressure plate and set grooved limit nuts approximately 1 inch from limit switches on each side (See Fig. 14).

▲ WARNING: STAY CLEAR OF ALL MOVING PARTS AND ELECTRICAL COMPONENTS OF OPERATOR WHILE TESTING!

3. ▲ Connect power.
4. Open gate electrically. If gate travels in correct direction and stops at open limit, proceed to step 7. If gate travels in the correct direction and nears the end of gate travel **BUT DOES NOT STOP**, STOP GATE with stop button or by removing power. Check to see if open limit has been tripped. If it has NOT been tripped:
 - (a.) Turn off power.
 - (b.) Manually move gate to midway position.
 - (c.) Set open limit nut closer to open limit switch.
 - (d.) Repeat procedure. If open limit switch has been tripped, but did not stop gate, consult the factory.
5. If direction of travel is wrong, turn off main power and recheck drive chain installation (See Fig. 4 & 6). If drive chain is correct, consult the factory.

▲ WARNING: UNDER NO CIRCUMSTANCES SHOULD CONTROL STATION WIRING BE ALTERED IF ROTATION IS INCORRECT. TO DO SO WILL CAUSE SOME CONTROL FUNCTIONS TO BE INOPERATIVE, WHICH MAY RESULT IN PERSONAL INJURY OR DAMAGE TO GATE AND/OR OPERATOR.

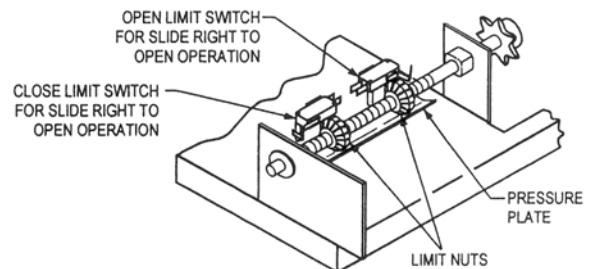

FIGURE 14

6. If operator functions properly, disconnect power, and proceed to limit adjustment.
7. Limit adjustment: Depress pressure plate and rotate grooved limit nut, on limit shaft, closest to open limit switch (See Fig. 14). To stop gate earlier, move limit nut closer to open limit switch. To stop gate later, back limit nut away from limit switch. **Note:** When making fine adjustments, turn limit nut 1/4 to 1/2 turn at a time, reconnect power and test run gate.
8. Repeat procedure for close limit adjustment.
9. After the desired open and closed position of gate has been obtained, make certain that a groove in both limit nuts is engaged by the pressure plate.

SERVICE:

Lubricate drive chain and idler sprocket bearings monthly with 30 WGT. oil. Periodically check all hardware (nuts, bolts, screws, etc..) for tightness.

PowerMaster Technical Service Line: **1-800-243-4476**

CONNECTION OF ADDITIONAL ACCESSORIES

Note: 24 VAC power is available from 2 terminal strip.

FIG. 1 SINGLE BUTTON:

1. Connect one lead to terminal #1.
2. Connect one lead to terminal #5. Single button will alternate between open, stop, and close.

FIG. 3 RADIO CONTROL:

(For open only using timer to close)

1. Connect (gray) contact leads to R1 and R2.
2. Connect (red) and (black) 24 VAC leads to R3 and R4.
3. Maintain leads between R/C terminal strip and 14 position terminal strip as wired from factory.
4. Turn on timer (see instruction manual).

(For open and close by radio)

1. Connect (gray) contact leads to R I and R2.
2. Connect (red) and (black) 24 VAC leads to R3 and R4.
3. Move (red) wire on 14 position terminal strip from T2 to I I.

FIG. 6 CARD READER, KEYPAD OR TELEPHONE ENTRY: (Open only)

1. Connect MO. to terminal #3.
2. Connect common to terminal #5. DO NOT Connect N.O. to terminal #6.

FIG. 6 EXIT LOOP: (Open only)

1. Connect common (yellow) to terminal #3.
2. Connect N.O. (blue) to terminal #5.
3. Connect (black) to 24 VAC power.
4. Connect (white) to 24 VAC power.
5. Connect (green) to chassis ground.
6. Connect (gray and brown) leads to ground loop.

FIG. 7 REVERSE LOOP: (Active only while closing)

1. Connect common (yellow) to terminal #8.
2. Connect N.O. (blue) to terminal #9.
3. Connect (black) to 24 VAC power.
4. Connect (white) to 24 VAC power.
5. Connect (green) to chassis ground.
6. Connect (gray and brown) leads to ground loop.

FIG. 10 SHADOW LOOP: (Swing gate only)

(Active only at full open limit)

1. Connect Common (yellow) to terminal #14.
2. Connect N.O. (blue) to terminal #10.
3. Connect (black) to 24 VAC power.
4. Connect (white) to 24 VAC power
5. Connect (green) to chassis ground.
6. Connect (gray and brown) leads to ground loop.
(Shadow loop will prevent closing when activated)

SINGLE BUTTON

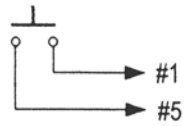

Figure 1

3 BUTTON STATION

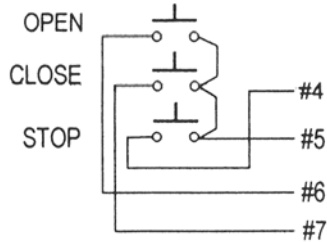
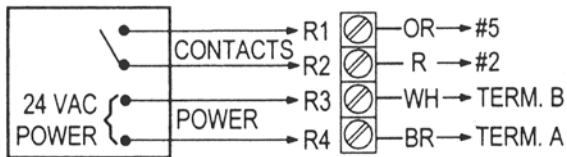

Figure 2

RADIO (OPEN ONLY)



RADIO OPEN/CLOSE

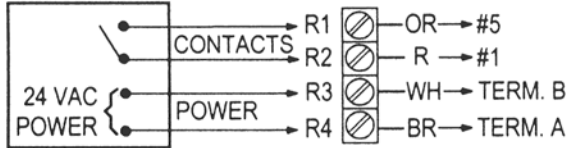

Figure 3

POWER FOR ACCESSORIES

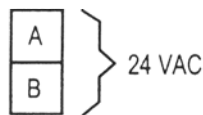

Figure 4

MASTER/SLAVE CONTROL WIRING

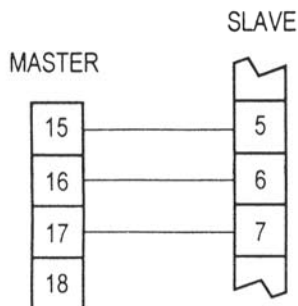

Figure 5

CARD READER, KEYPAD, TELEPHONE ENTRY OR FREE EXIT LOOP

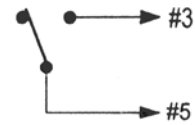

Figure 6

REVERSE

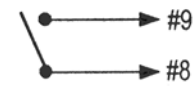

Figure 7

NON-CONTACT SAFETY DEVICES (PHOTO-CELLS)



Figure 8

CONTACT TYPE SAFETY DEVICES (EDGES)

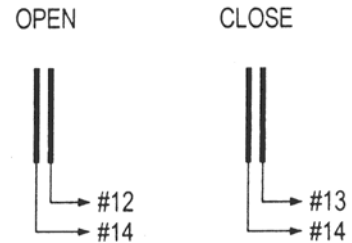

Figure 9

SHADOW LOOP (SWING GATE ONLY)

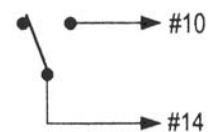

Figure 10