



INSTALLATION AND OWNER'S MANUAL

MODEL MSW

Medium Duty Swing Gate Operator

UL 325 and UL 991 Listed

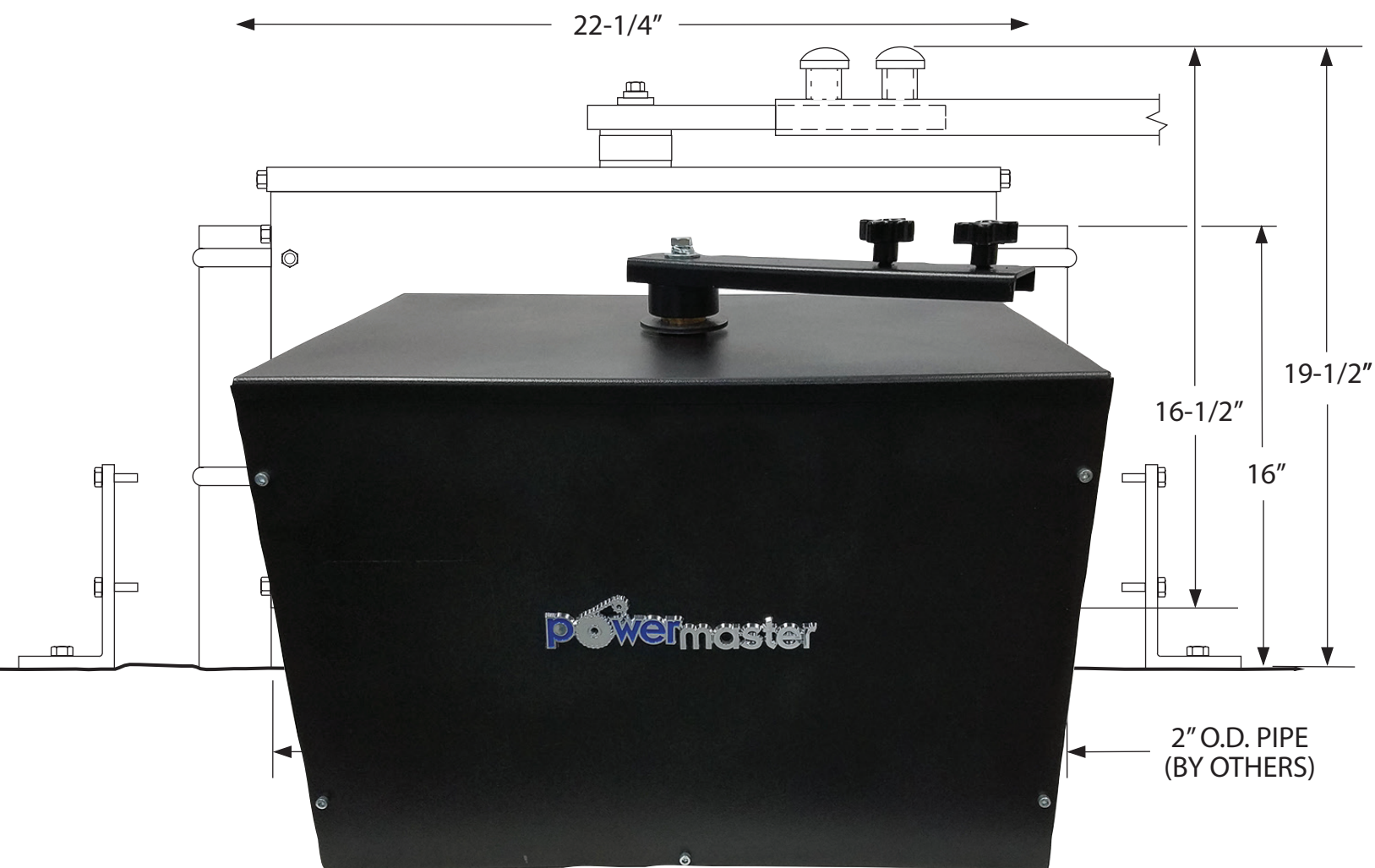

Serial #:
Date Installed:
Your Dealer:

READ THIS MANUAL CAREFULLY
BEFORE INSTALLATION OR USE.
SAVE THESE INSTRUCTIONS.



IMPORTANT!

FOR SWING GATE OPERATING SYSTEMS, SAFETY IS EVERYONE'S BUSINESS.

Automatic gate operators provide convenience and security to users. However, because these machines can produce high levels of force, it is important that all gate operator system designers, installers, and end users be aware of the potential hazards associated with improperly designed, installed, or maintained systems. Keep in mind that the gate operator is a component part of a total gate operating system.

The following information contains various safety precautions and warnings for the system designer, installer and end user. These instructions provide an overview of the importance of safe design, installation, and use.

Warnings are identified with the ▲ symbol. This symbol will identify some of the conditions that can result in serious injury or death. Take time to carefully read and follow these precautions and other important information provided to help ensure safe system design, installation and use.

▲ WARNING: Gate operators are only one part of a total gate operating system. It is the responsibility of purchaser, designer, and installer to ensure that the total system is safe for its intended use. All secondary entrapment safety devices must be **RECOGNIZED** by UL to ensure the safety of the complete operating system.

UL INSTALLATION AND SAFETY CONSIDERATIONS

INSTALLATION CLASSES

CLASS I - RESIDENTIAL VEHICULAR GATE OPERATOR

A vehicular gate operator (or system) intended for use in a home of one to four single-family dwellings, or a garage or parking area associated therewith.

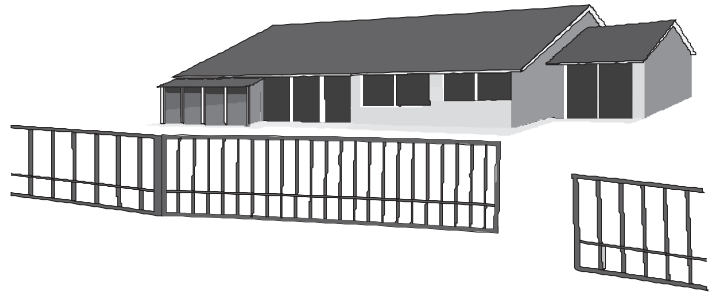

CLASS II – COMMERCIAL/GENERAL ACCESS VEHICULAR GATE OPERATOR

A vehicular gate operator (or system) intended for use in a commercial location or building such as a multifamily housing unit (five or more single family units), hotel, garages, retail store or other building servicing the general public.

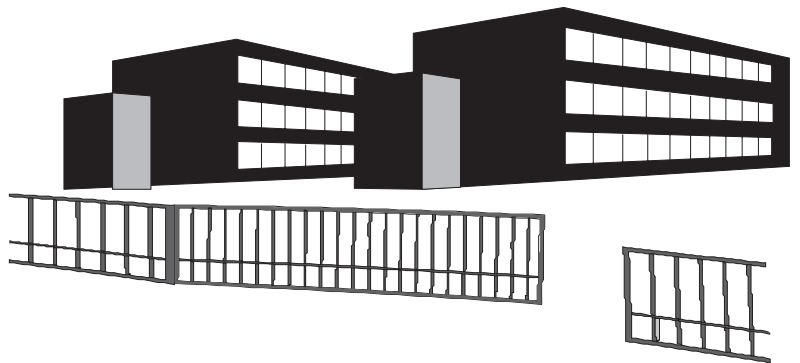

CLASS III - INDUSTRIAL/LIMITED ACCESS VEHICULAR GATE OPERATOR

A vehicular gate operator (or system) intended for use in an industrial location or building such as a factory or loading dock area or other locations not intended to service the general public.

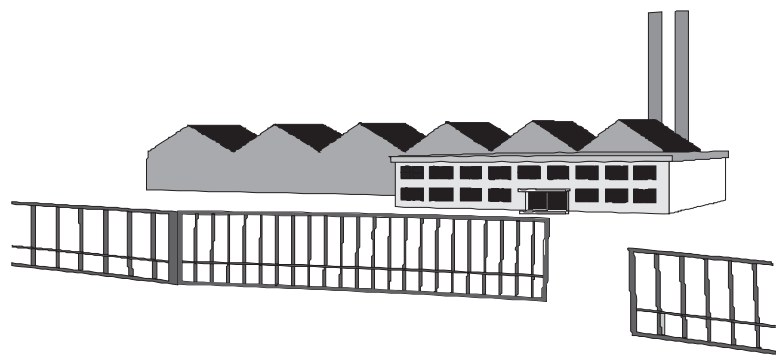

CLASS IV - RESTRICTED ACCESS VEHICULAR GATE OPERATOR

A vehicular gate operator (or system) intended for use in a guarded industrial location or building such as an airport area or other restricted access locations not servicing the general public, in which unauthorized access is prevented via supervision by security personnel.

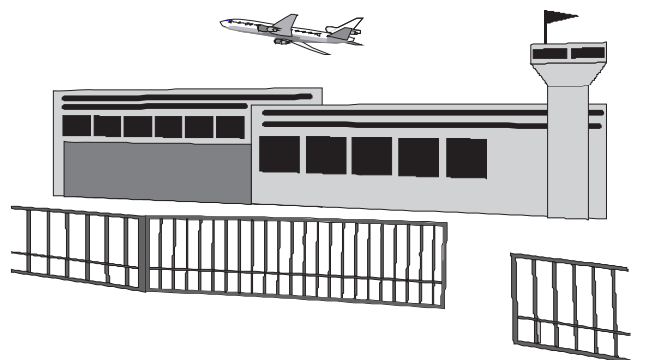

SYSTEM DESIGNER SAFETY INSTRUCTIONS

1. Familiarize yourself with the precautions and warnings for the installer. Users are relying on your design to provide a safe installation.
2. The operator is supplied with a primary obstruction sensing entrapment protection system. The installation must also have a secondary entrapment protection system installed, such as photoelectric sensors or an electric edge system.
3. When designing a system that will be entered from a highway or main thoroughfare, be sure the system is placed far enough away from the road to eliminate traffic backup. Distance from the road, size of the gate, usage levels, and gate cycle/speed must be considered to eliminate potential traffic hazards.
4. Swing gates have two potential entrapment zones you must avoid. Make sure they are protected as shown in the following diagram.

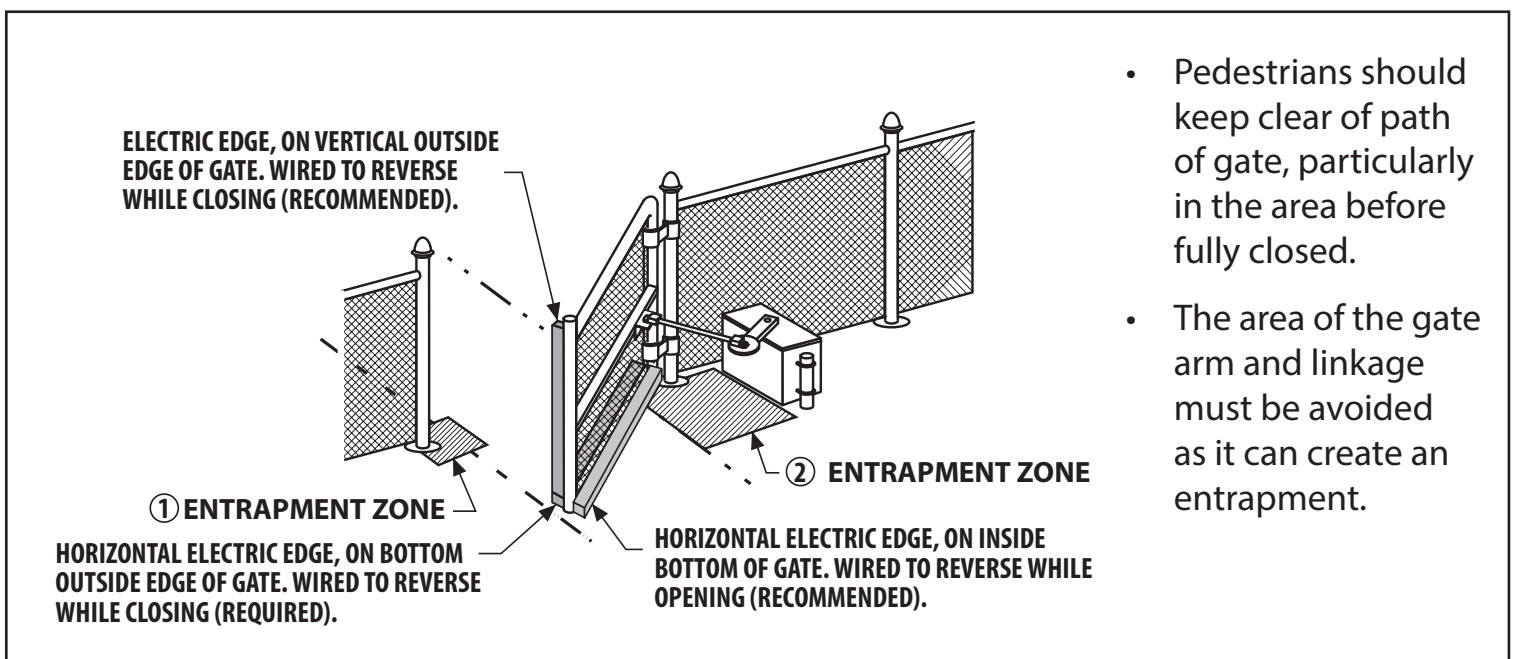

WARNING

THIS GATE SYSTEM IS FOR VEHICULAR TRAFFIC ONLY. A SEPARATE PEDESTRIAN ENTRANCE MUST BE PROVIDED.

The illustrations and descriptive captions provide precautions to help eliminate injuries or fatalities. Familiarize yourself with them when designing the total system.

5. Design the gate system so a person cannot reach over, under, around, or through the gate to operate any controls. Never place controls on the gate operator itself.

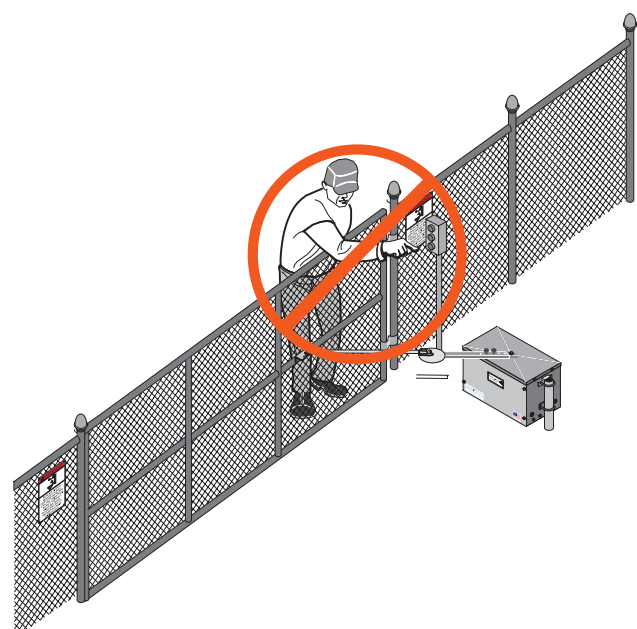

INSTALLER SAFETY INSTRUCTIONS

BEFORE INSTALLATION

- ▲ 1. Check to see that the operator is proper for this type and size of gate and its frequency of use. If you are not sure, consult factory.
 - ▲ 2. Check to see that there are no structures adjacent to the area, which may pose a risk of entrapment when gate is opening or closing.
 - ▲ 3. You must ensure that the gate has been properly installed and works freely in both directions. Replace or service any worn or damaged gate hardware prior to installation. A freely moving gate will require less force to operate and enhance the performance of the operator as well as the safety devices used within the system.
 - ▲ 4. Install the gate operator on the inside of the property and/or fence line. **DO NOT** install an operator on the public side of the gate.
 - ▲ 5. Severe injury or death can result from entrapment by a gate. The operator is supplied with an obstruction sensing primary entrapment protection system. Additional safety equipment such as electric edges or photocell sensors must be installed to provide the required secondary entrapment protection system. For assistance in selecting the correct type of safety equipment, consult the factory.
 - ▲ 6. Review the operation of the unit and become familiar with the manual operation procedure and safety features of the system.
 - ▲ 7. You must install a pushbutton control or key switch to allow for normal operation of the gate if the automatic controls do not work. Locate the push button or key switch and small warning placard within sight of the gate in a secured area at least 10 feet or more from any moving parts of the gate or operator.
 - ▲ 8. Outdoor or easily accessed gate controls should be of the security type to prohibit unauthorized use. Please consult your local distributor concerning the types and specifications of available controls.
-

DURING INSTALLATION

- ▲ 1. Be aware of all moving parts and avoid close proximity to any pinch points.
- ▲ 2. Disconnect power at the control panel before making any electric service connections. Connection location for controls and safety equipment can be found on the wiring diagram, and in this manual.
- ▲ 3. Know the procedure for disengaging and manually operating the unit.
- ▲ 4. Adjust the open and close force adjustment on the control board, in each direction, to the minimum force required to operate the gate smoothly. **DO NOT increase the force adjustment setting to make up for rough spots in gate travel - FIX THE GATE INSTEAD!**

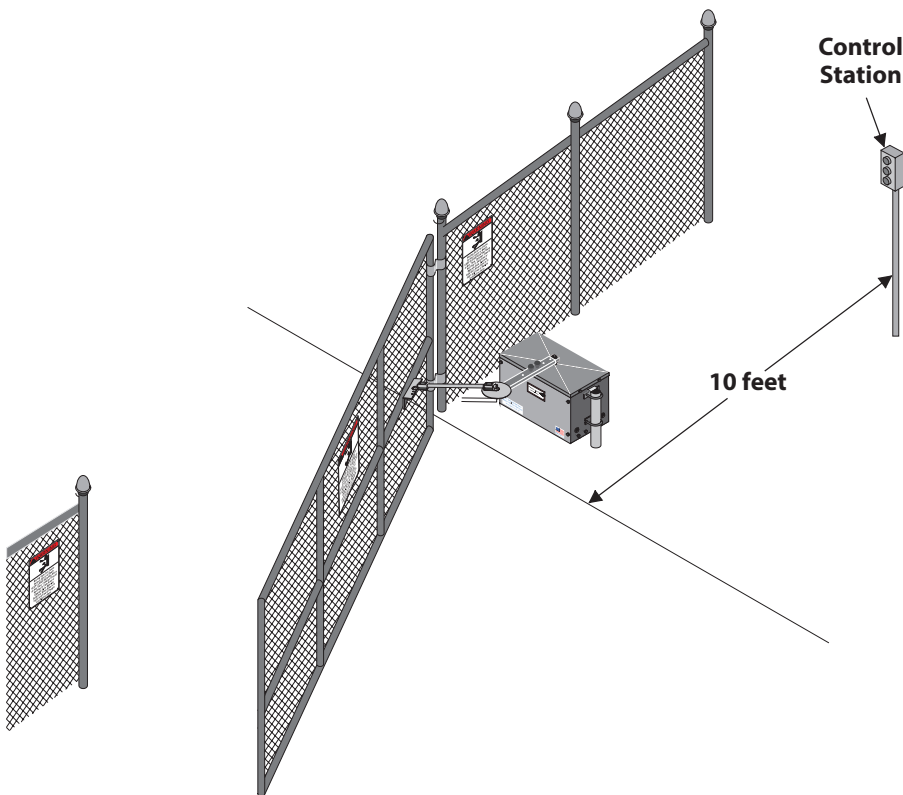

- ▲ 5. Locate the controls at least 10 feet from the moving gate so that the user can observe the gate operation, but is not able to come in contact with the gate while operating the controls.

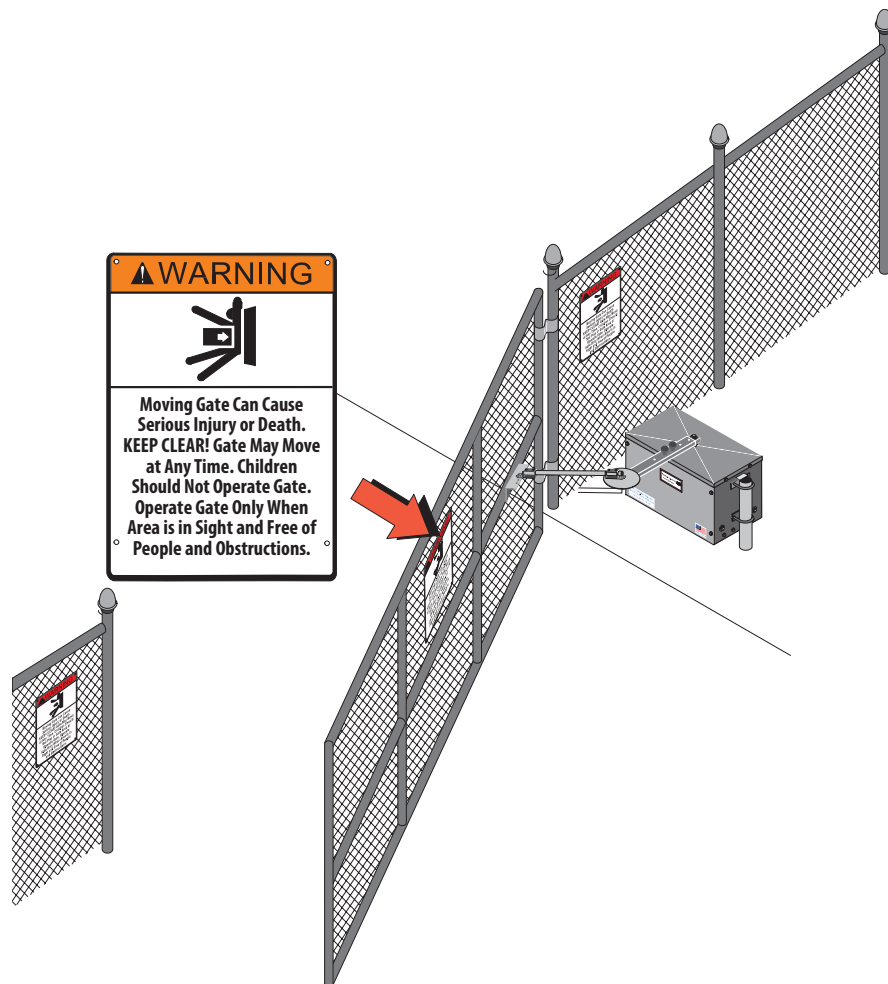

- ▲ 6. Attach large warning signs provided to each side of the gate or fence in the most conspicuous place. Mount control station and smaller warning placard together within sight of the gate opening.

AFTER INSTALLATION

- ▲ You are responsible for ensuring that the end user understands the basic operations and safety systems of the unit, INCLUDING THE MANUAL OPERATION PROCEDURE.
- ▲ Point out that the safety instructions in brochure are the responsibility of the end user, and then **LEAVE THIS MANUAL WITH THE END USER.**

END USER SAFETY WARNINGS

The manufacturer of the gate operator does not know what type of gate you have, or what type of automatic system is installed on your gate. Be sure you've been fully instructed on the sequence of operation for your specific gate system(s). Keep the gate properly maintained and have a qualified service person make repairs.

- ▲ 1. Be sure the following safety instructions are distributed to all persons authorized to use your gate.

- ▲ 2. **KEEP GATEWAY CLEAR (Front and Back) AT ALL TIMES.** Your automatic gate is not for pedestrian use. No one should ever cross the path of the moving gate.

- ▲ 3. DO NOT allow children to play near your gate, or to operate the gate.

- ▲ 4. DO NOT operate your gate system unless you can see it when the gate moves.

- ▲ 5. Be sure a pushbutton or key switch has been installed for manual electric operation in the event your radio or card key does not work. Any mounted control station should be located a minimum of 10 feet from the gate so the gate cannot be reached through or touched. Any pushbutton located in a building should be installed within sight of the gate.

- ▲ 6. DO NOT operate any controls without watching the movement of the gate.

- ▲ 7. Your gate system is required to have a primary and a secondary entrapment safety system installed and maintained.

- ▲ 8. If your gate closes automatically, loop detectors should be installed to detect the presence of a vehicle.

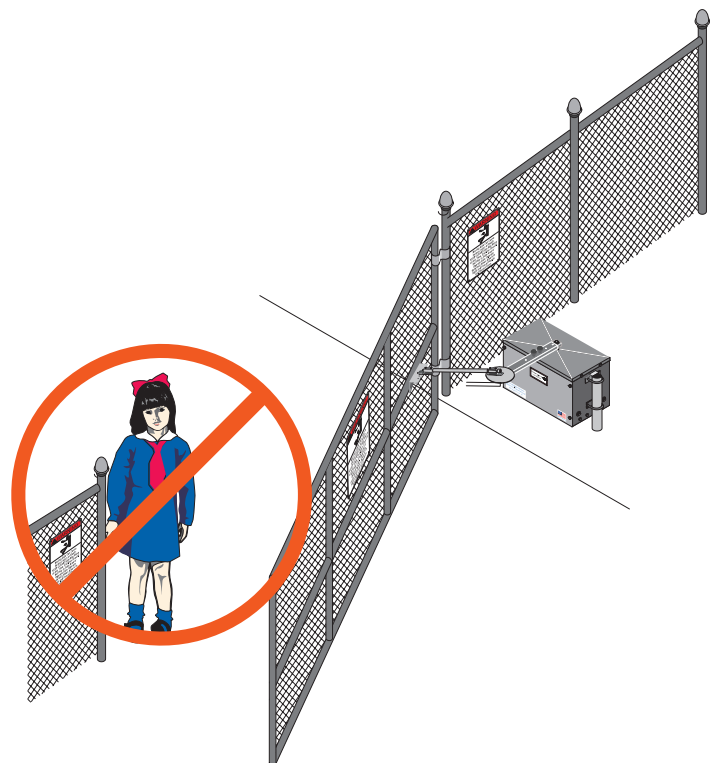
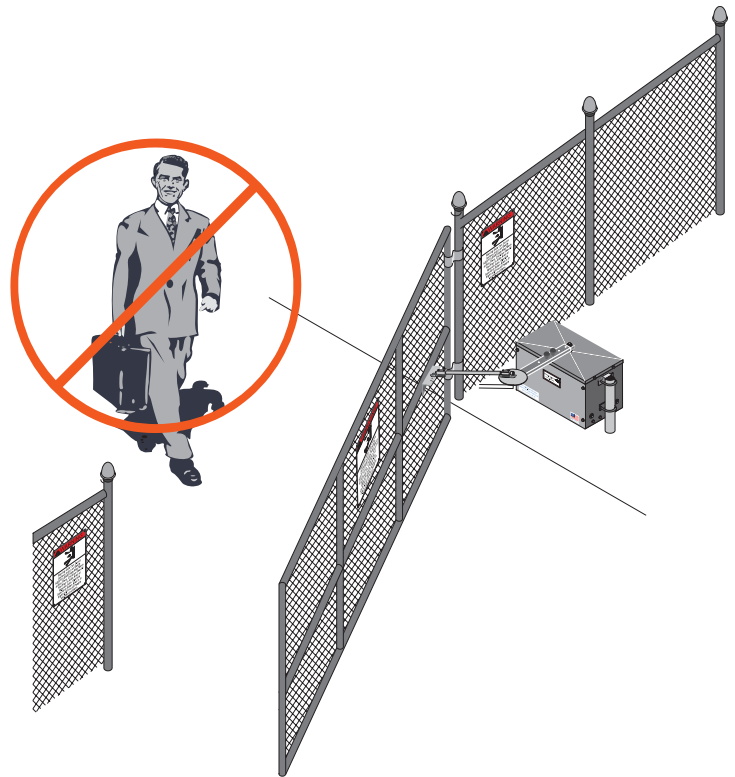

- ▲ 9. DO NOT increase force adjustment to compensate for a damaged gate. The gate should always be maintained to operate manually as easily as possible to provide maximum protection.
- ▲ 10. Check all safety systems at least once per month for the correct force, speed and sensitivity. Gate must reverse when hitting a rigid object, or when a non-contact sensor is activated. If these functions are observed to operate improperly, discontinue use and have it serviced immediately!
- ▲ 11. You are responsible for ensuring that warning signs are installed and maintained on both sides of your gate.
- ▲ 12. To ensure safe operation of this equipment, you must read this safety manual and keep it for reference.
- ▲ 13. Swing gates have two potential entrapment zones you must avoid. Make sure they are protected.

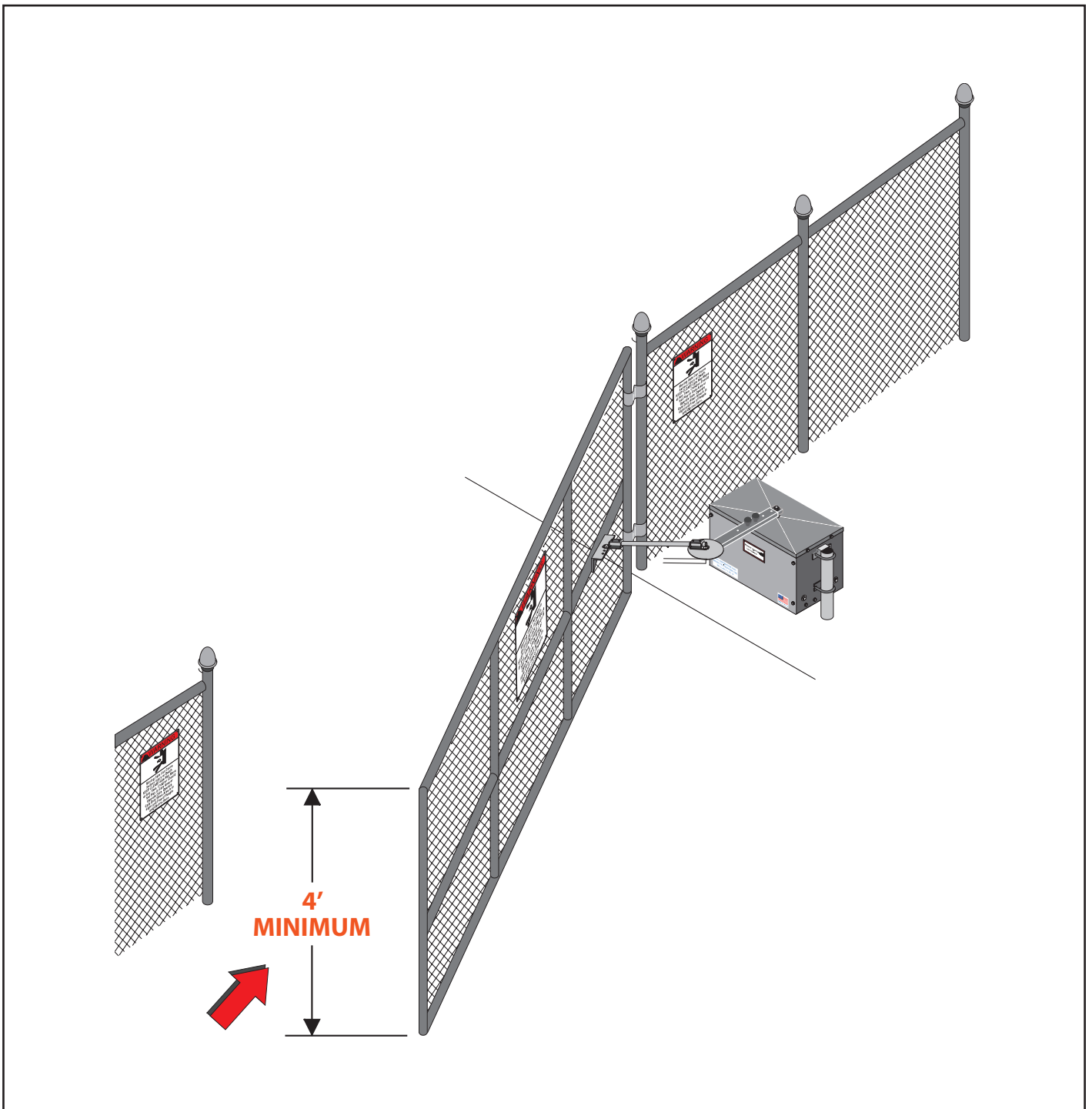

MANUAL OPERATION

Your operator is equipped with an emergency disconnect for manual operation. Be sure you know how to properly use this feature. To disengage operator, follow the procedure in the diagram.

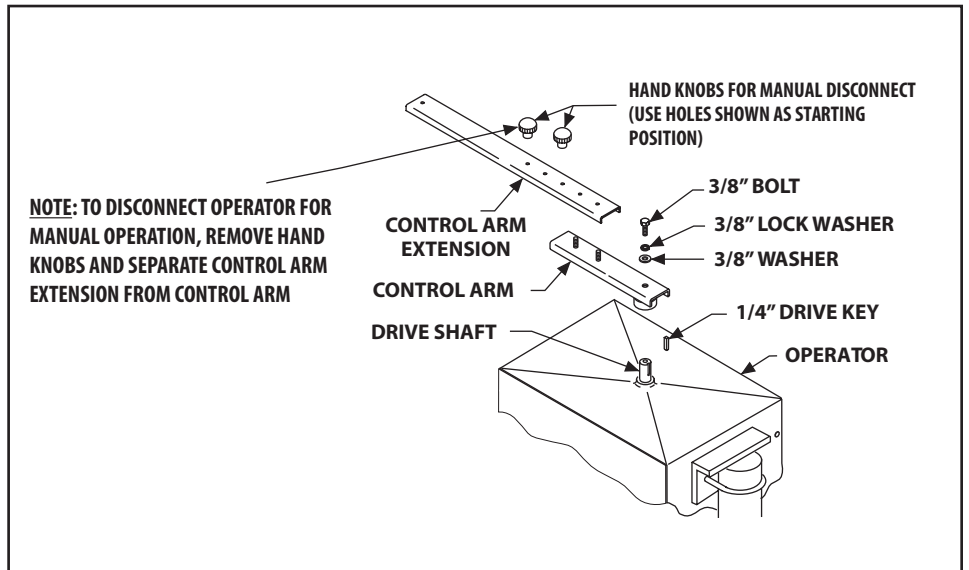

INSTALLATION INSTRUCTIONS & SET-UP PROCEDURE

 WARNING	DO NOT APPLY POWER UNTIL TOLD TO DO SO! RISK OF ELECTRICAL SHOCK OR INJURY MAY RESULT!
--	---

BEFORE INSTALLING OPERATOR

IMPORTANT: Operator should always be mounted inside the gate. Determine whether the installation is LEFT HAND or RIGHT HAND by the direction the gate moves in order to open, when viewed from inside the fence.

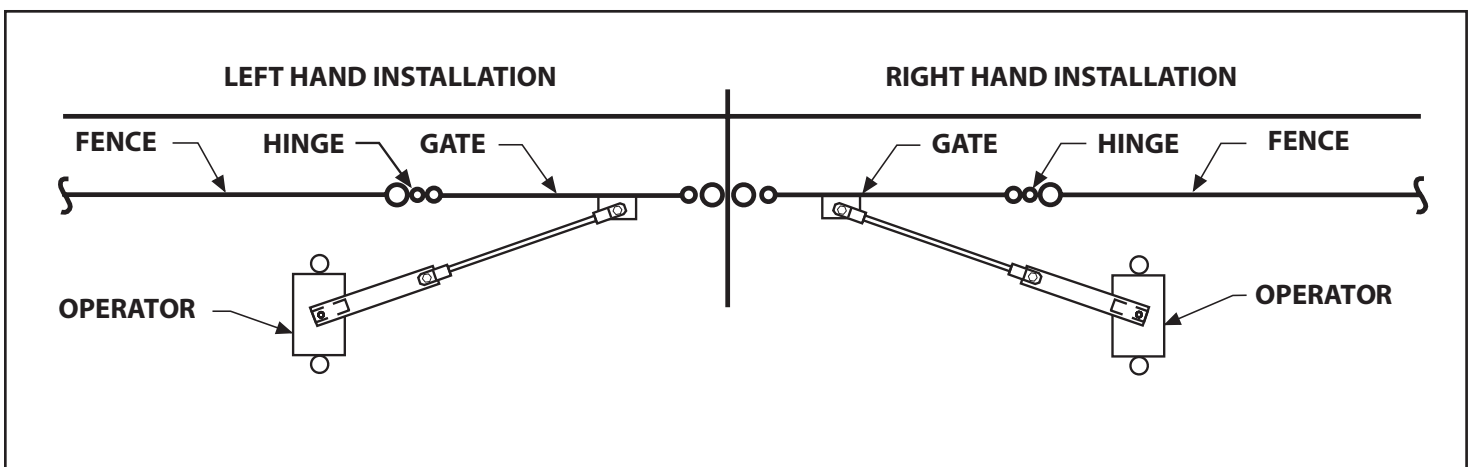

1. Gate must swing freely to fully opened and fully closed position.
2. The operator will be located as shown above, for left and right hand installation.

INSTALLATION LAYOUT

1. Layout mounting post and electrical conduit locations as shown in figures below. Excavate required area for conduit installation and cementing of mounting posts (Minimum of 2 feet deep. Check local codes.)
2. Set mounting post and electrical conduit in place.
3. Pour cement to secure mounting posts and let cure for two days prior to operator installation.

Note: Distance between mounting posts and relative location to gate is very important! Operator must be installed perpendicular to the fence.

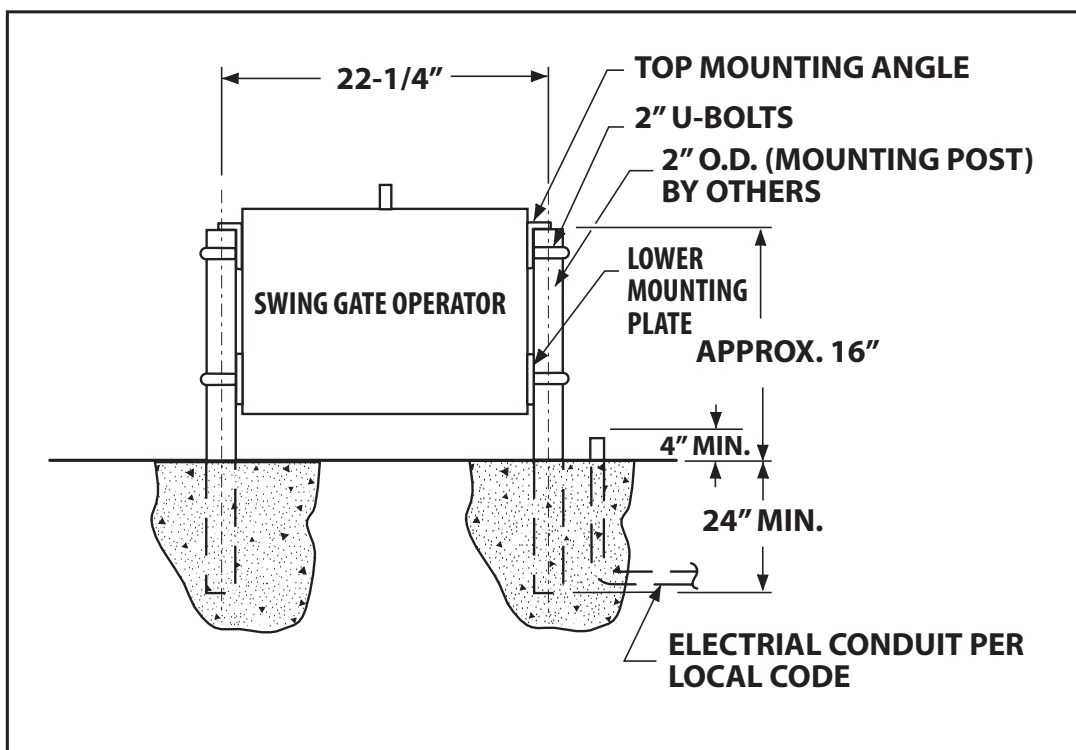
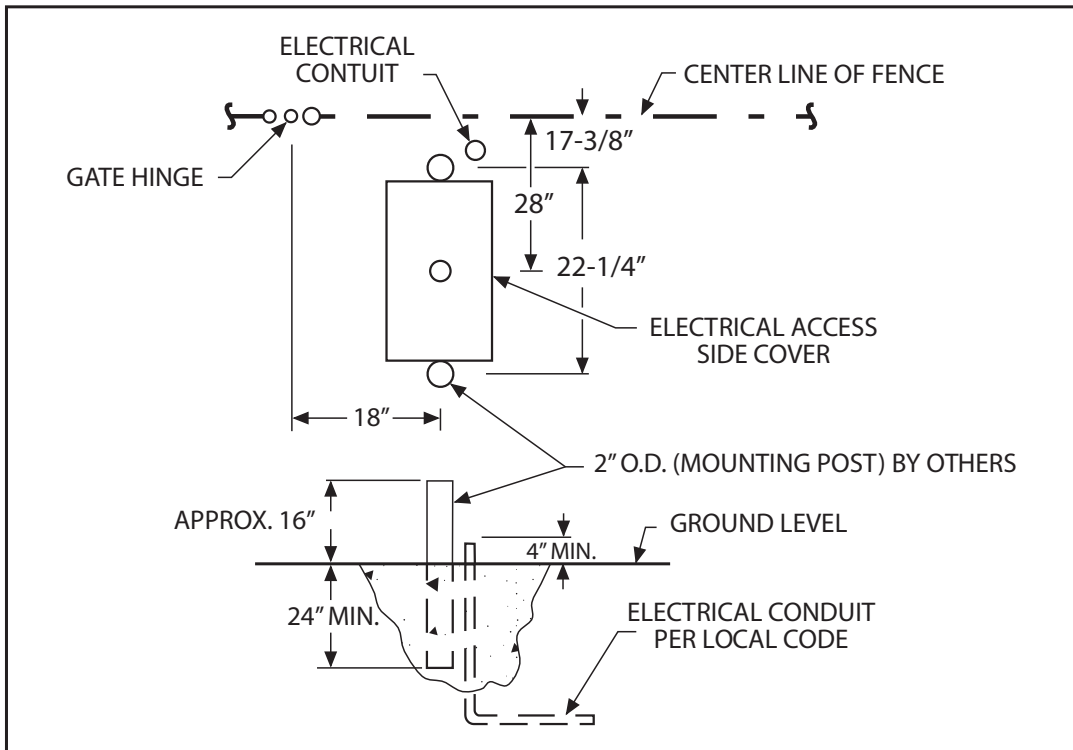

OPERATOR INSTALLATION

1. Mount operator on posts with mounting angles and mounting plates. Secure position with 2" U-bolts and hardware provided.
2. Set control arm on output shaft of operator without drive key, and install control arm extension using hand knobs to secure position.

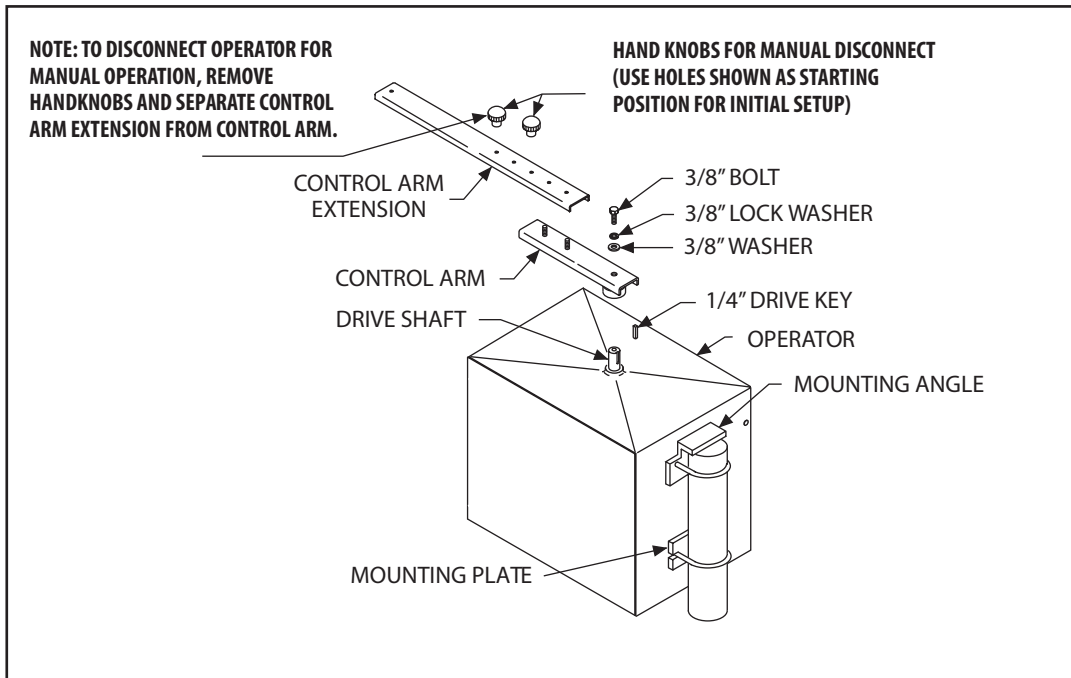

3. Install end fittings on connecting rod assembly and attach one end of assembly to end of control arm extension.

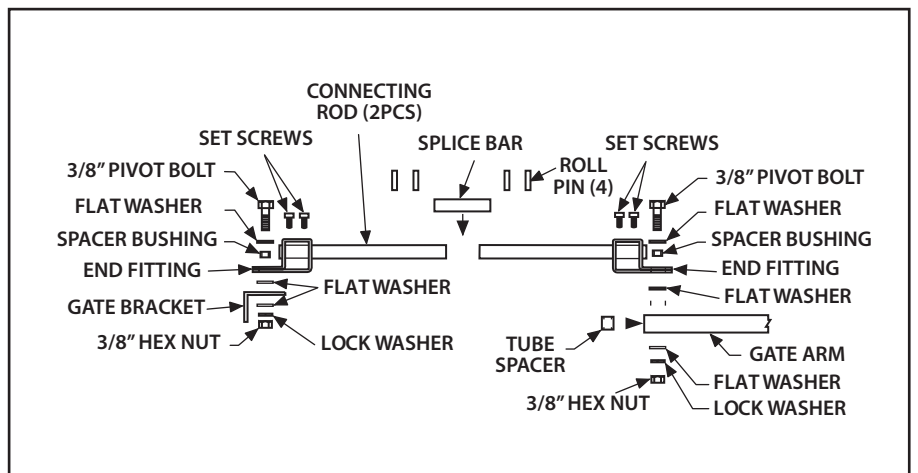

4. Install gate bracket on remaining end of connecting rod.
5. Locate gate bracket in position on gate and clamp in position.
6. Move control arm to its maximum close position. Control arm and connecting rod must be straight in line.

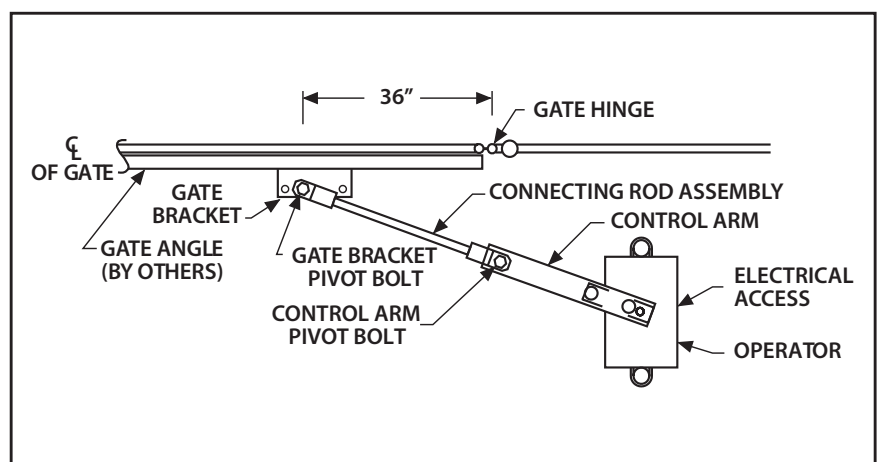

Note: Adjustment can be made in (4) locations to get desired closed position, as described below. Always start with Option "a".

- a. Move the gate bracket to left or right of the 36 inch starting position.
- b. Change length of connecting rod assembly.
- c. Relocate control arm extension on control arm to a different hole pattern then start position.
- d. Move connecting rod bolt in gate bracket to a different hole.

7. Move control arm to its open position

Note: Arm and connecting rod should almost double over each other. This is important for smooth operation and longevity of the operator.

Note: Open position of gate may be adjusted slightly with limit switch adjustment, but when finished, open position of control arm assembly should be as close as possible to that shown in the diagram. If mechanical adjustments are made to achieve desired open position of gate, repeat **Steps 6 & 7**, since this will affect the closed position.

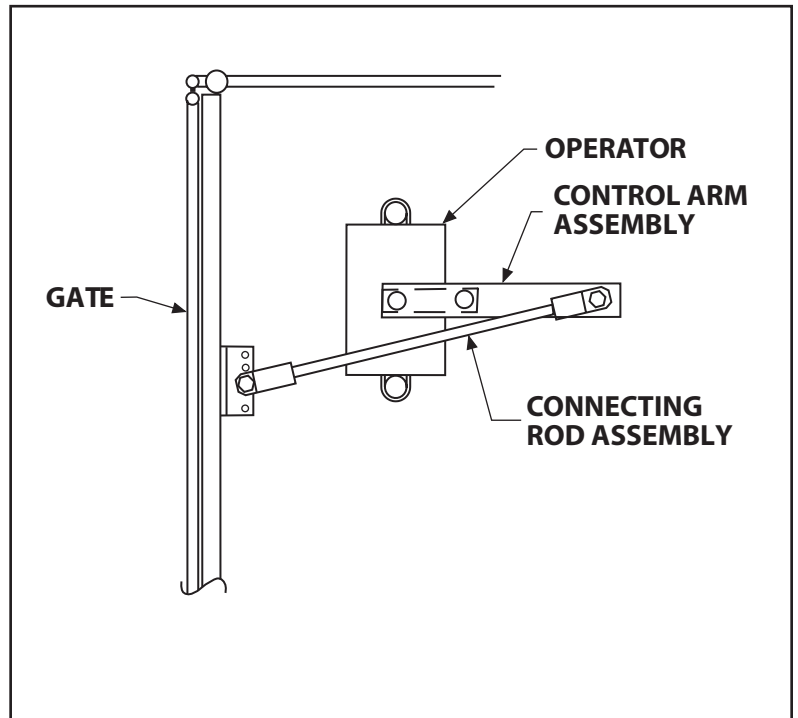

8. When the desired open and closed gate position have been achieved, place gate in the fully closed position and remove control arm extension from control arm.
9. Remove control arm from operator drive shaft and insert drive key.
10. Replace control arm on operator drive shaft with drive key and secure with 3/8 inch bolt.
11. Replace control arm extension on control arm and secure with hand knobs.
12. By turning the internal drive pulley by hand, move the control arm to somewhere in its normal drive segment.

Note: If operator was ordered as a right or left hand unit from the factory, the control arm position will be somewhere in its normal travel segment and the limit switches will be set at an approximate open and close position. Final adjustments will be made later after power is connected.

If the hand of the operator is to be changed in the field as described in the following section than before the control arm extension is replaced as in Step #11, proceed to **Step #12**.

13. Control arm extension may now be attached to control arm.

ELECTRICAL SET-UP AND CONNECTIONS



WARNING

DO NOT APPLY POWER UNTIL TOLD TO DO SO! RISK OF ELECTRICAL SHOCK OR INJURY MAY RESULT!

NOTE: Before connecting the operator, use a voltmeter to determine that the electrical service is 115V. THIS OPERATOR CANNOT BE CONNECTED AT 230 VOLTS. Damage will result which is not covered under warranty.

NOTE: Wiring to operator must use watertight materials in accordance with local electric code. See the following wire gauge/distance charts for proper sizing. Master/Slave installations should have SEPARATE power supply wiring or length of wire runs should be figured at half that shown on the chart. This unit must be grounded in accordance with N.E.C. and local codes.

LINE VOLTAGE	HP	WIRE GAUGE				
		14 AWG	12 AWG	10 AWG	8 AWG	6 AWG
115VAC	1/2	150'	250'	400'	500'	650'

LOW VOLTAGE WIRE GAUGE/ DISTANCE CHART
24 AWG: UP TO 150'
20 AWG: 150' - 200'
18 AWG: 250' - 1,500'
Control wiring should be run as twisted pairs. DO NOT run control wires in the same conduit as power wires, telephone wires, or loop detector leads.

1. Be sure the power switches at source, and at the operator are **OFF**.
2. Connect incoming power lines and ground wire as shown below.

Hot leg (Black) to Black; Neutral (White) to White; Ground to Ground Screw.

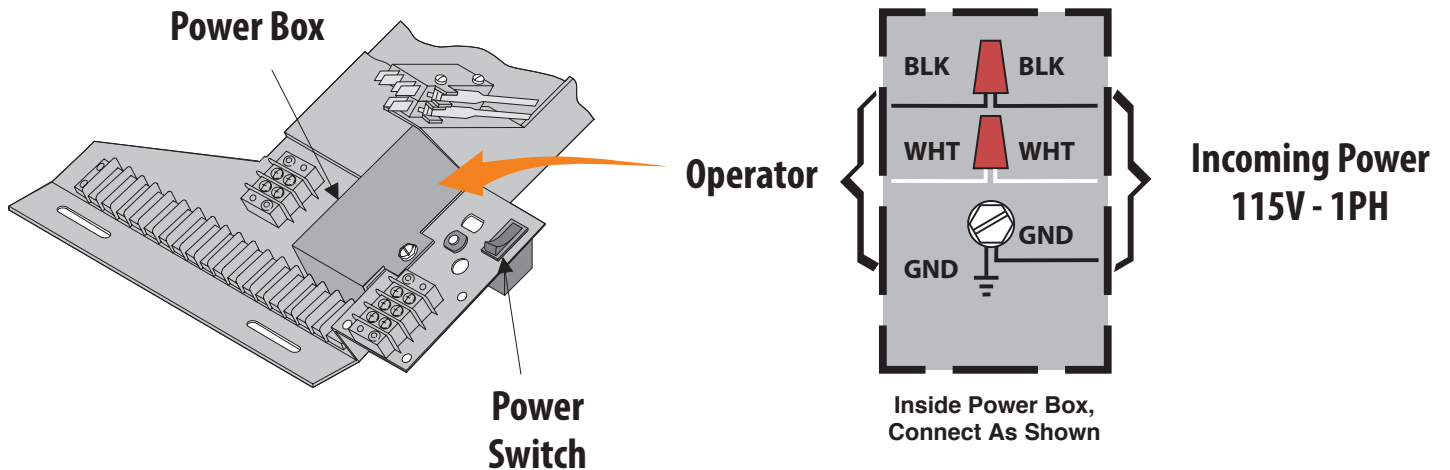

NOTE: In order to properly run and check the operator at various stages during the setup procedure, it is suggested that a three button control station be connected at this time.

LIMIT ADJUSTMENT PROCEDURE

NOTE: Operator should be completely installed, mechanically and electrically, before attempting to set limit switch cams.

NOTE: For Master/Slave installation, travel time for the Master operator must be set longer than the Slave operator.

OPEN LIMIT SWITCH ADJUSTMENT

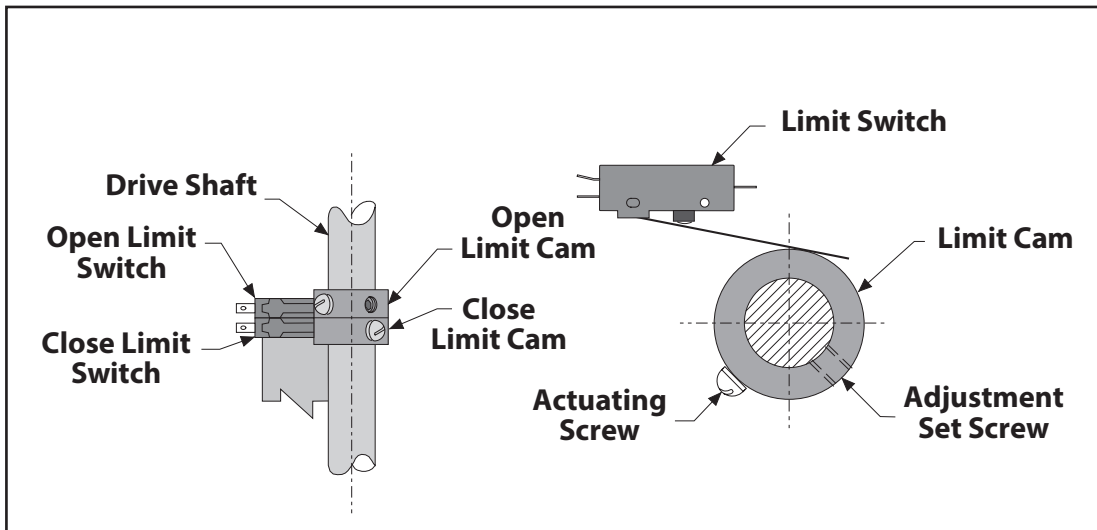

1. Turn on power. Press **OPEN** button on control station. Gate should stop before full open position is reached. If gate does not stop when open position is reached, **PRESS STOP BUTTON!**
2. To adjust gate for more open travel, loosen **Open Limit Cam Set Screw** and rotate limit cam in the opposite direction drive shaft rotates to open gate. Re-tighten set screw after adjustment (See **Figure 11**).
3. If it was necessary to stop gate, adjust **Open Limit Switch Cam** for less open travel by rotating the cam in the same direction that the drive shaft rotates to open the gate.
4. Press **CLOSE** button and stop gate in mid travel with **STOP** button.
5. Repeat procedure until desired open setting is obtained.

CLOSE LIMIT SWITCH ADJUSTMENT

1. Press **CLOSE** button on control station. Gate should stop before full closed position is reached. If gate does not stop when close position is reached, **PRESS STOP BUTTON!**
2. To adjust gate for more close travel, loosen **Close Limit Cam Set Screw** and rotate limit cam in the opposite direction drive shaft rotates to close gate (See **Figure 11**).
3. If it is necessary to stop gate, adjust **Close Limit Switch Cam** for less close travel by rotating the cam in the same direction that the drive shaft rotates to close the gate.
4. Press **OPEN** button and stop gate in mid travel with **STOP** button. Repeat procedure until desired close setting is obtained.

NOTE: After both **OPEN** and **CLOSE** limit adjustments are complete, check that both limit cam set screws are tight.

TIMER TO CLOSE OPTION

The operator is equipped with a **Timer to Close** option for use with control devices, such as a radio control or card key control. The **AUTO RE-CLOSE TIMER** adjustment screw is located on the printed circuit board. The operator is shipped from the factory with this timer preset to the **OFF** position, fully counter-clockwise. As the timer adjustment screw is rotated clockwise, the closing of the gate can be delayed from 2 seconds to 60 seconds.

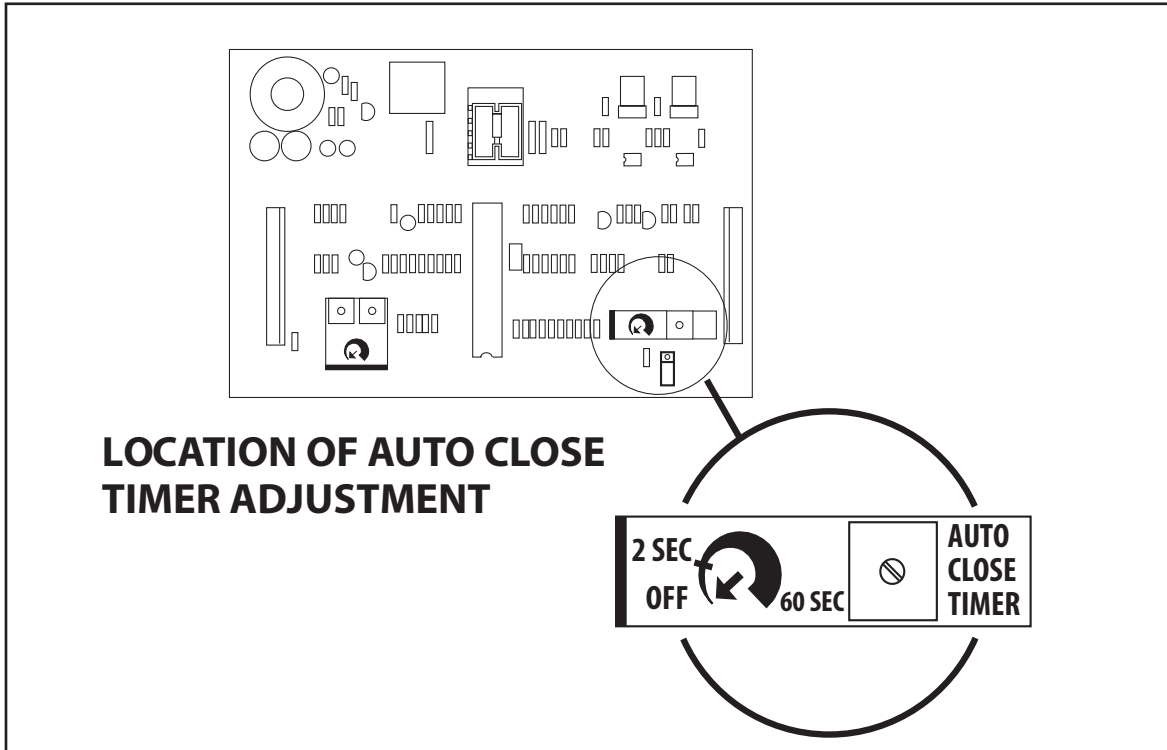

ACCESSORY CONNECTIONS

RADIO CONTROL INSTALLATION

A three or four wire radio control receiver can be installed on this operator. This radio control receiver can only be used to open the gate, therefore the **TIMER TO CLOSE** option must be activated for closing.

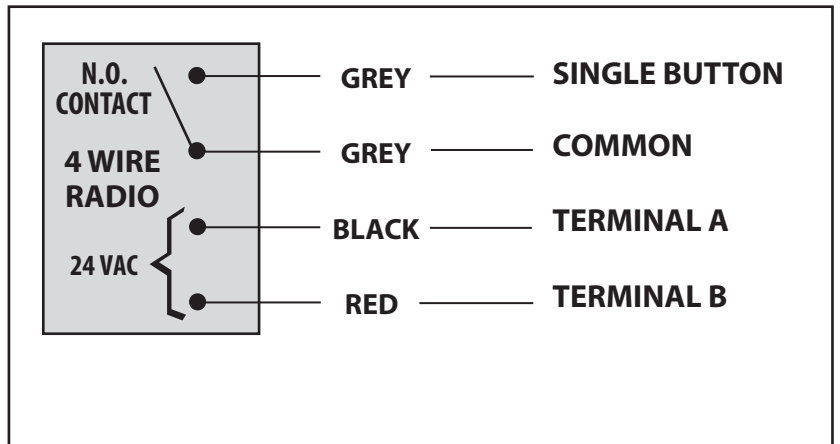

NOTE: If your radio's connecting wires are not color coded as shown, see the radio's installation manual to determine which wires are for the normally open contacts and which require the 24VAC Power Supply.

LOOP DETECTOR SYSTEMS AND INSTALLATION

The diagram on the right depicts the typical loop options for a Swing Gate installation.

1. The **Exit Loop** provides a signal to open the gate when a vehicle enters the loop zone.
2. The **Reversing Loop** protects a vehicle in the loop zone from being contacted with the gate by overriding any close signal while the gate is open, and by reversing the gate if closing.
3. The **Shadow Loop** protects a vehicle in the loop zone from being contacted with the gate by overriding any close signal while the gate is in the full open position.

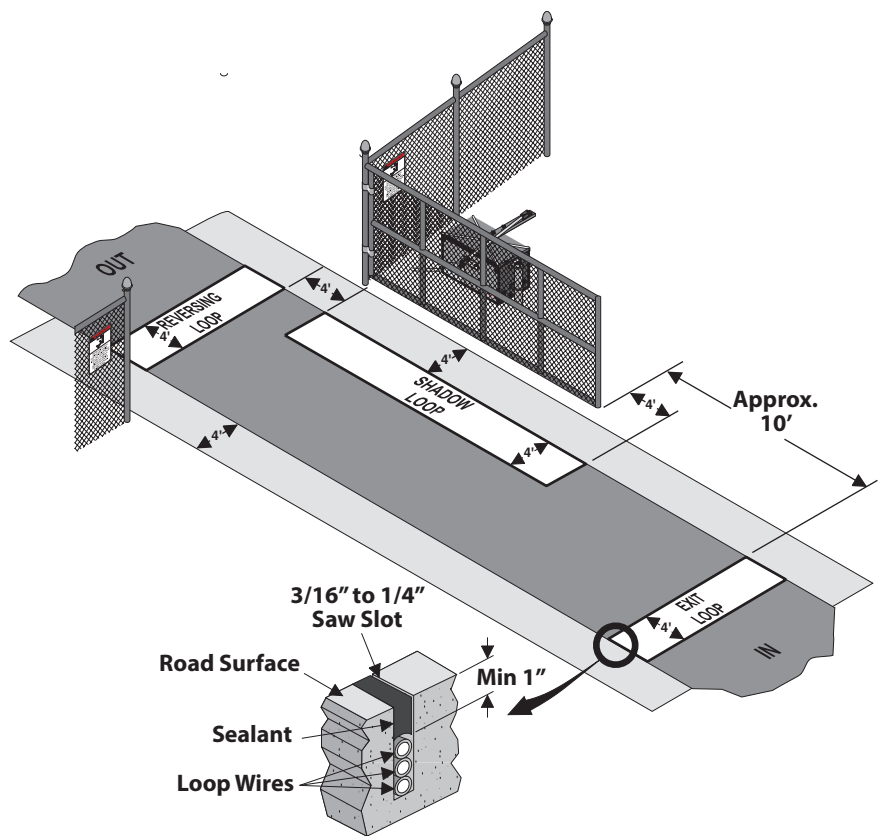

LOOP INSTALLATION

1. Lay out the desired loop locations per the diagram. The standard size chart on the following page will give an approximate length of wire required for various loop dimensions and number of turns required.

STANDARD LOOP LAYOUTS FOR APPROX. 36" HEIGHT DETECTION

LOOP SIZE	# OF TURNS	LOOP WIRE LENGTH (FT)
4' X 4'	4	64'
4' X 6'	4	80'
4' X 8'	3	72'
4' X 10'	3	84'
4' X 12'	3	96'
4' X 14'	3	108'
4' X 16'	3	120'
4' X 18'	3	132'
4' X 20'	3	144'
4' X 22'	3	156'
4' X 24'	3	168'
4' X 26'	3	180'
4' X 28'	3	192'
4' X 30'	2	136'
4' X 32'	2	144'
4' X 34'	2	152'
4' X 36'	2	160'
4' X 38'	2	168'
4' X 40'	2	176'

CAUTION: The loop wires and lead-in wires must be a continuous piece of wire without splices. The amount of lead-in wire required must be added to these lengths for total wire required. Only use wire intended for this type of application (Type XHHW insulation 16AWG).

NOTE: Buried steel from drains or other systems may affect functioning of the loop system. Check with the factory for advice on any special installations. Call 1-800-243-4476.

- Cut the required groove at the locations laid out in Step#1 according to the diagram below.

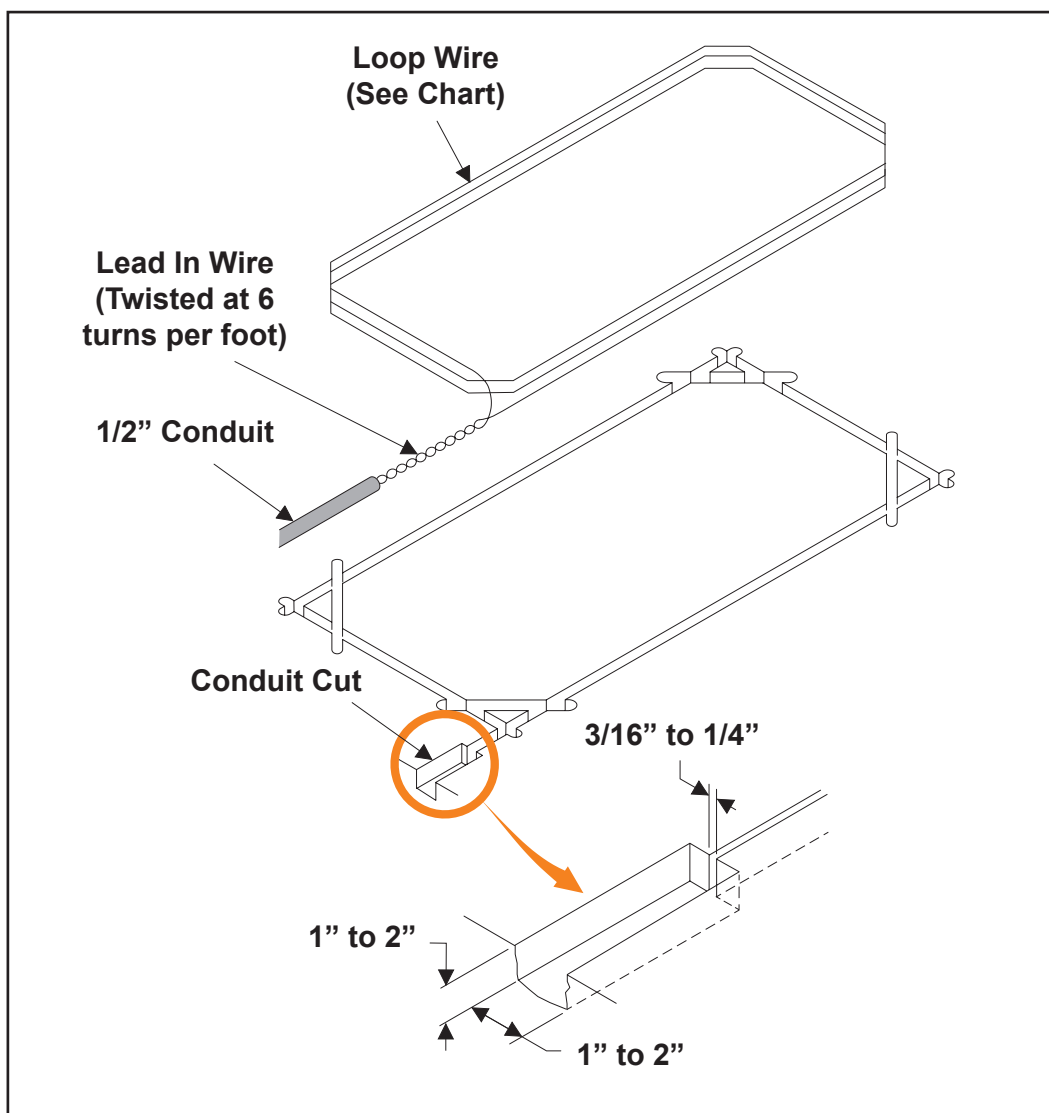

3. Leaving enough wire for the lead-in, insert the specified number of turns of wire in the cut grooves (See chart).

CAUTION: Be careful not to damage the wire insulation during installation.

4. After completing the required number of loop turns, twist the ends together at the rate of 6 turns per foot to form the lead-in.
5. Seal the lead-in wire in the conduit to prevent moisture seepage into the conduit.
6. Fill over the loop wires in the groove with a recommended loop sealant. Contact your distributor for available sealants.
7. Mount the loop detector in the operator and connect the wire loop.
8. Connect loop detector to the control board.

SAFETY DEVICE CONNECTIONS

INHERENT OBSTRUCTION SENSING DEVICE

NOTE: The gate MUST move smoothly and easily in manual operation before attempting this adjustment.

This unit is supplied with a current sensing system, which will stop the gate when it encounters an obstruction, and then backs the gate off approximately 2 inches. If the gate is started again and a second encounter occurs before hitting a limit switch, the gate will stop and sound a warning signal. A constant pressure control will then be needed to start the gate.

This sensing system has sensitivity adjustments located on the printed circuit board. The force required to activate the system may be adjusted in both **OPEN** and **CLOSE** directions separately. Start at minimum and increase force setting until it is just over what is required to move the gate smoothly without any nuisance tripping.

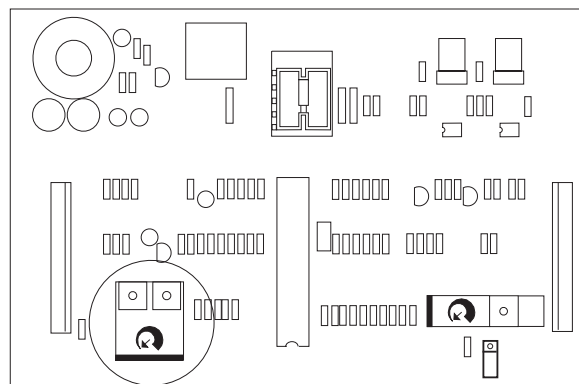
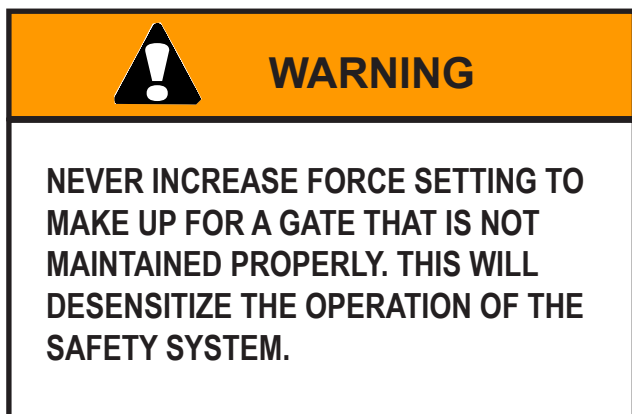

LOCATION OF OVERLOAD FORCE ADJUSTMENT

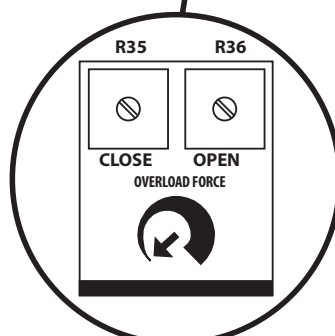

SECONDARY OBSTRUCTION SENSING DEVICES

Another sensing device (Either a contact or a non-contact system) must be installed and connected to this unit to increase protection against entrapment per UL requirements.

NOTE: All safety device contacts must be **NORMALLY OPEN**.

NOTE: 24 VAC power is available at marked terminals for devices that may require it (e.g. photo eyes, wireless edges, etc.).

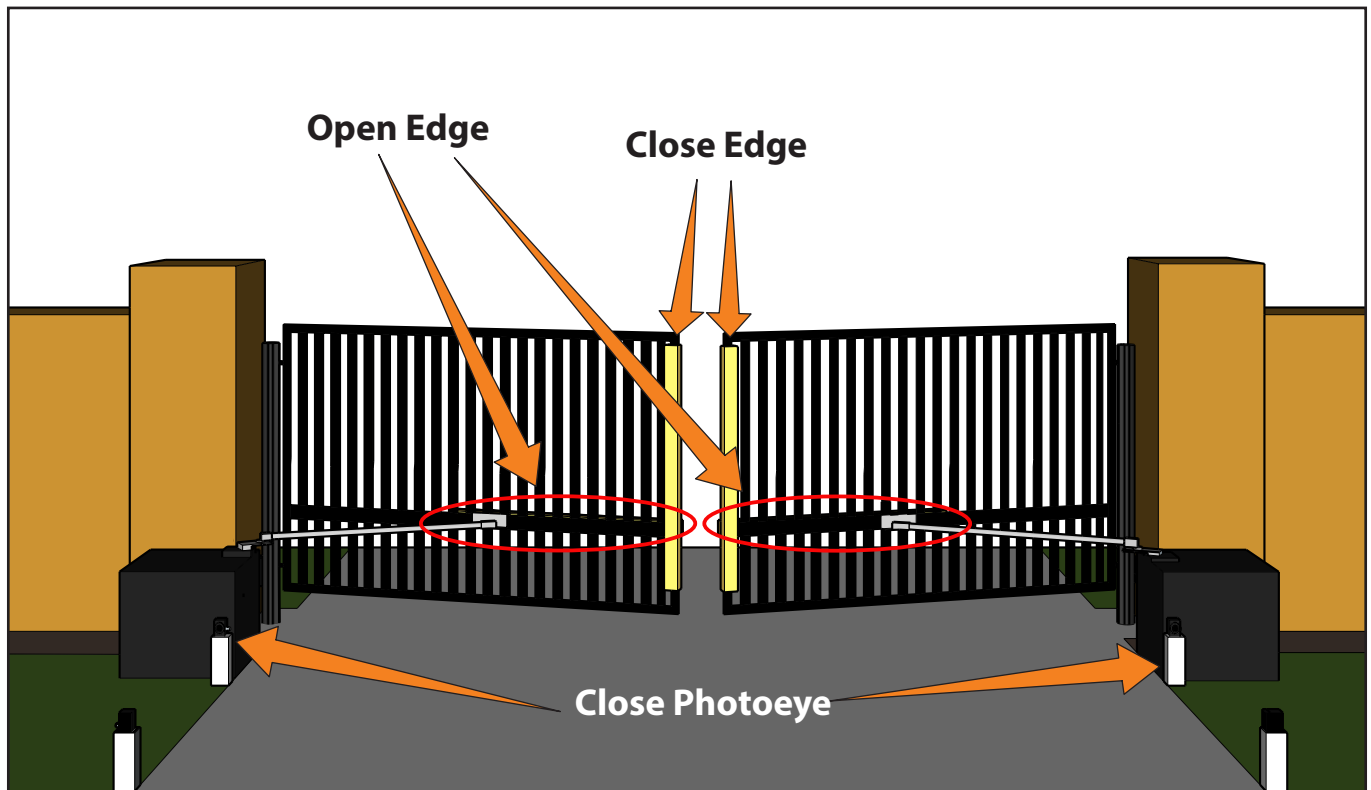

CONTACT SENSOR INSTALLATION

NOTE: Wireless sensors must be installed so there is no signal interference.

NOTE: All hard wiring to safety edges must be installed so there is no threat of mechanical damage to wiring between components when the gate is moving.

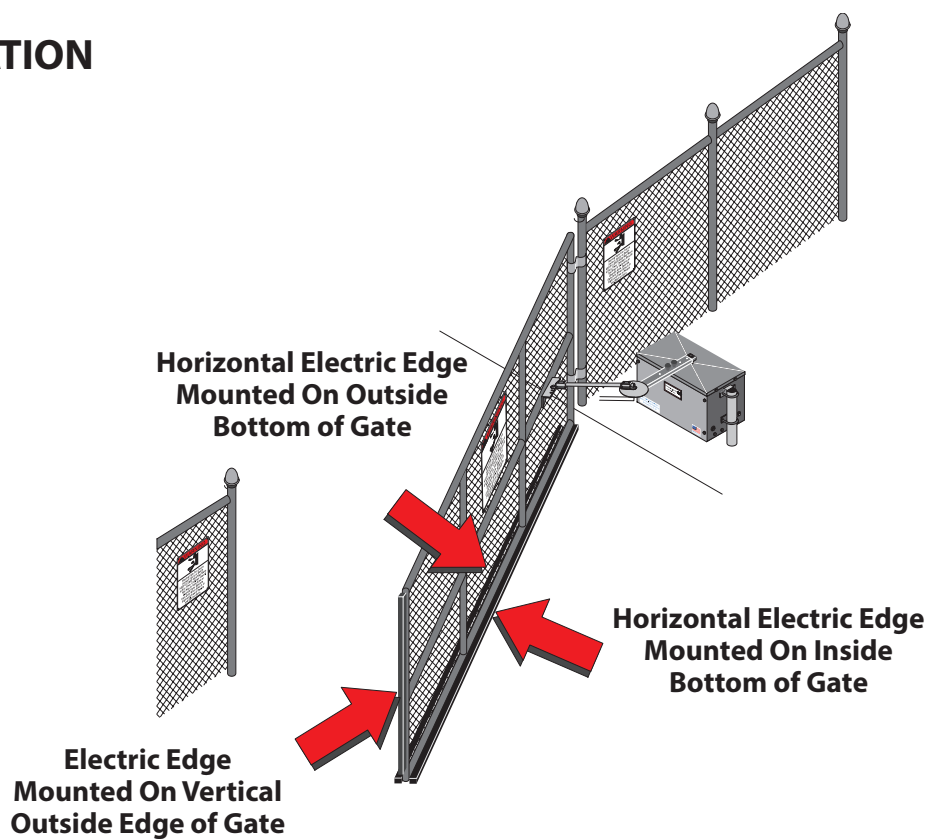

1. Install electric edge sensors in locations shown on the following page.

NOTE: A separate pedestrian gate must be installed if there is no other entry access but the vehicular gate.

2. Connect contact sensor edges to the control board.
3. After sensors are mounted and electrically connected, turn on the power.
4. Test the **CLOSE OBSTRUCTION SENSING SYSTEM** for proper operation by depressing the vertical edge sensing strip while the operator is running closed.

NOTE: The operator should **STOP AND REVERSE** a short distance and then stop.

5. Run the operator to the open limit and repeat Step #3 for the outside horizontal edge.
6. Test the open obstruction sensing system by depressing the inside horizontal edge sensor while the gate is opening.

NOTE: The operator should repeat the **STOP AND REVERSE** procedure.

NOTE: If an edge is activated twice, or a second edge is activated before a limit is hit (full open or close), operator will stop and sound a warning horn. To reactivate system, turn operator power switch **OFF** then **ON**.

DuaIGate

Primary

Secondary

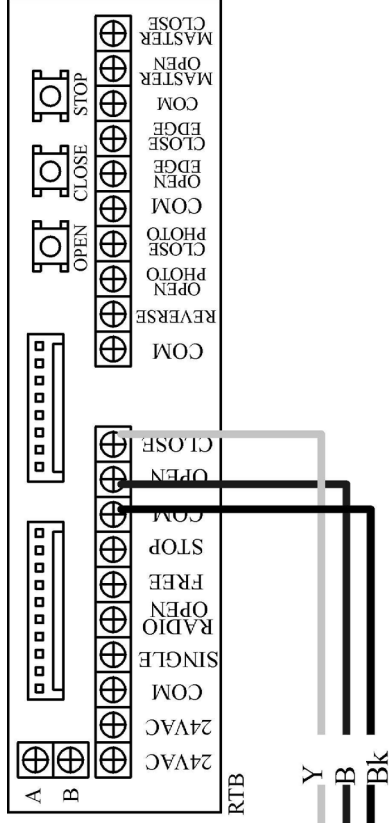
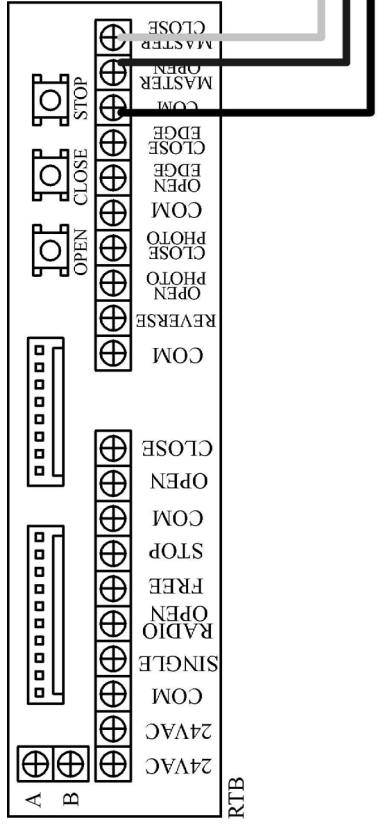

Antenna

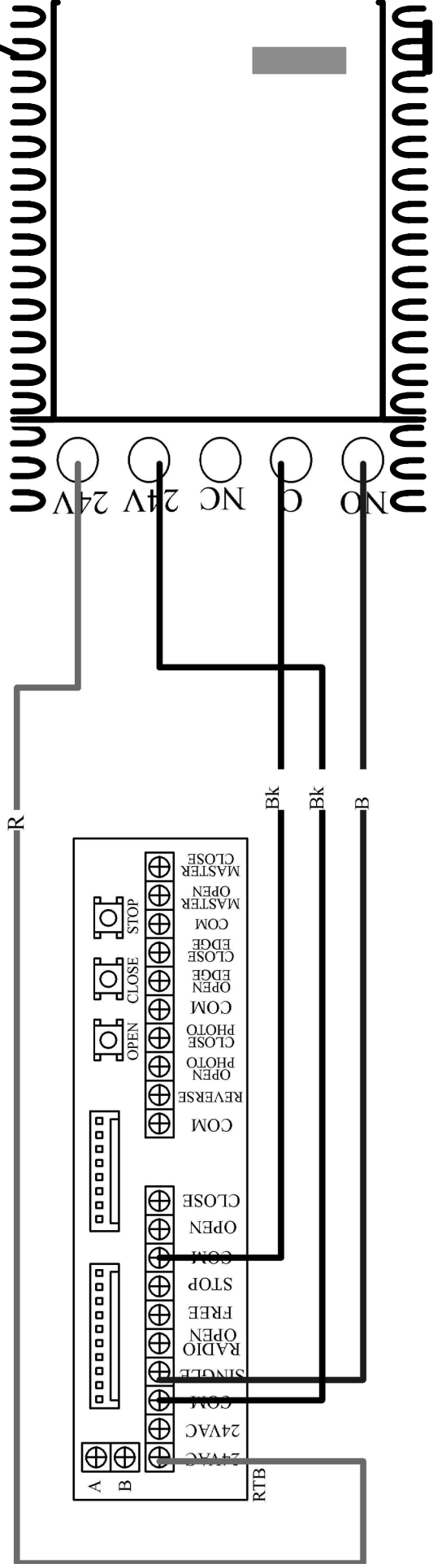

NON-CONTACT SENSOR INSTALLATION

1. Install photoelectric cell as close to **FULL OPEN** and **FULL CLOSED** position of gate as possible.
2. Photocells should be installed across the gate opening and behind the gate at least 10 inches above ground (see image on right).

NOTE: A separate pedestrian gate must be installed if there is no other entry access but the vehicular gate.

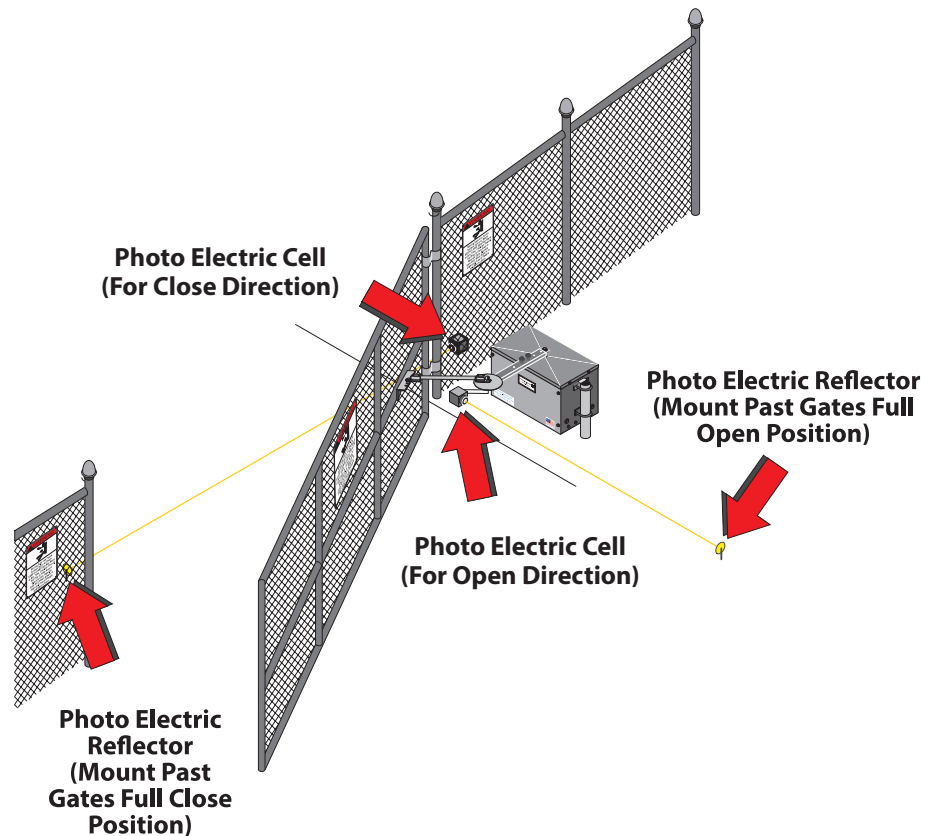

AFTER SENSORS ARE CONNECTED

1. Turn **ON** power.
2. Make sure the photo-beams are properly aligned per the manufacturer's specifications.
3. Test the **CLOSE OBSTRUCTION SENSING SYSTEM** for proper operation by blocking the beam across the gate opening while the gate is running closed.

NOTE: The gate should **STOP AND REVERSE** a short distance and then **STOP**.

4. Run operator to **CLOSE** limit.
5. Test the **OPEN OBSTRUCTION SENSING SYSTEM** by blocking the beam mounted at the back area of the gate while the gate is running open.

NOTE: The operator should repeat the **STOP AND REVERSE** procedure.

MAINTENANCE SUGGESTIONS

Periodically check all hardware (nuts, bolts, screws, etc) for tightness.

PowerMaster

Limited 5-Year Warranty

PowerMaster warrants all GATE OPERATORS (Swing, Slide, Barrier categories) to be free of defects in materials and workmanship for a period of five (5) years from date of manufacture, provided that product has been registered. A one year warranty applies if product has not been registered.

ELECTRICAL PARTS (including boards, switches, relays, etc):

PowerMaster warrants electrical parts for a two (2) year period, provided that product has been registered. A one year warranty applies if product has not been registered.

If any part is found to be defective during this period, new parts will be furnished free of charge. Failure of this product due to misuse, improper installation, alterations, vandalism, acts of God, or lack of maintenance is **not** covered under this warranty, and voids any other implied warranties herein.

PowerMaster is **not responsible** for any labor charges incurred in connection with the installation of warranted parts.

In order to activate this warranty, the registration form found with your operator **MUST BE COMPLETED AND RETURNED WITHIN THIRTY CALENDAR DAYS FROM DATE OF PURCHASE**. Visit our website at www.PowerMasterNY.com and click on the **Register your Product** link.

You can also register via email to PMtech@PowerMasterNY.com.

If registration is not activated, a **ONE YEAR** warranty from date of manufacture will apply for all claims.

REGISTRATION INFORMATION

Operator Information

Model MSW _____ Date of Purchase _____
Serial # _____ Date of Installation _____
Wiring Diagram (WD) # _____

Installer's Information

Company Name _____
Address _____
Address 2 _____
City, State, Zip _____
Telephone # _____
Contact Name _____

The end user should retain this information for their records and to obtain warranty service.

Need Technical Support?

Visit: www.PowerMasterNY.com/technical-information

Call us toll free @ 1-800-243-4476

Email us: PMtech@PowerMasterNY.com



[/PowerMasterOperators](#)



[/PowerMaster](#)



[/company/PowerMaster](#)



Scan **QR Code**
with your Smart
phone to **find us**
on the web!

www.PowerMasterNY.com

The logo for PowerMaster, featuring the word 'power' in a lowercase, outlined font with a gear icon integrated into the letter 'o', followed by 'master' in a bold, lowercase sans-serif font. Below the logo, the text 'MANUFACTURED BY V.E. POWER DOOR CO, INC.' is written in a smaller, all-caps sans-serif font.
powermaster
MANUFACTURED BY V.E. POWER DOOR CO, INC.