

Best Quality
GATE OPENER
 The strongest solution for swing gates

DESIGNED FOR RESIDENTIAL APPLICATION

KIT PW320/PW330 SWING GATE OPENERS USER MANUAL

PW320/PW330 electro-mechanical swing gate operators are designed for residential application. Stylish appearance of the gear motors with innovative design of motor release by specialized key in case of power failure. The equipment of the hall sensor imbedded in the gear motor provides intelligent operation of the gate movement. Over-current function with adjustable torque setting provides various choices for the gate installation.

PW320
 Gear Motor

PW330
 Gear Motor

PC200
 Control Box

PF-1
 Flashing Light

PH-1
 Photocells

PR-1
 Transmitter

PKS-1
 Key Selector

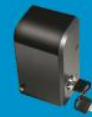
PPB-1
 Push Button

PEL-1
 Electric Latch

PS-1
 Stopper

INDEX

1. Warnings	2
2. Product Description	3
2.1 Applications	3
2.2 Description of The Automation	3
2.3 Description of Devices	3
2.3.1 PW320/PW330 Electromechanical Gear Motors	4
2.3.2 PC200 Control Box	4
2.3.3 PH-1 Photocells	4
2.3.4 PKS-1 Key Selector	5
2.3.5 PPB-1 Push Button	5
2.3.6 PF-1 Flashing Light	5
2.3.7 PR-1 Radio Transmitter	5
2.3.8 PEL-1 Electric Latch and PS-1 Stopper	6
3. Installation	6
3.1 Notes of Motors in Operation	6
3.1.1 Tools in Installing	6
3.1.2 Motors, Components and Its Installation in Illustration	7
3.2 Power Connection	7
3.2.1 Notes for Power Connection	7
3.3 Installation	8
3.3.1 Preparation for Motor Installation	8
3.3.2 Installation of The Gear Motors	10
3.3.3 PKS-1 Key Selector	12
3.3.4 PPB-1 Push Button	13
3.3.5 PF-1 Flashing Light	14
3.3.6 PH-1 Photocells	15
3.3.7 PEL-1 Electric Latch and PS-1 Stopper	16
3.3.8 PC200 Control Box	19
4. Dip Switch Setting	22
4.1 SW1 Dip Switch Setting	22
4.1.1 Slowdown Adjustment (Dip 1.S/F Set)	22
4.1.2 Over-current Adjustment (Dip 2.Over2 & Dip 3.Over1)	23
4.1.3 Gate Auto-close Adjustment (Dip 4.Auto 3, Dip 5.Auto 2 & Dip 6.Auto 1)	23
4.1.4 Photocells Adjustment (Dip 7.Photo)	23
4.1.5 Flashing Light Adjustment (Dip 8.Light)	23
4.2 SW2 Dip Switch Setting.	23
4.2.1 Electric Latch Adjustment (Dip 5.Latch)	23
4.2.2 Slowdown Speed Adjustment of The Gear Motors (Dip 6.Slow)	23
4.2.3 Operation Speed Adjustment of The Gear Motors (Dip 7.Fast)	24
4.2.4 Single and Dual Gate Operation Adjustment (Dip 8.Ds/Set)	24
4.3 LED Indication	24
4.4 Transmitter Memorizing and Erasing Process	25
4.5 System Learning Process	25
4.6 Gate Operation.	25
4.7 Gate-moving Logic	26
5. Trouble Shooting	27
6. Technical Characteristics	28
6.1 PW320	28
6.2 PW330	28
6.3 PC200 Control Box	29
6.4 PH-1 Photocells	29
6.5 PKS-1 Key Selector	29
6.6 PPB-1 Push Button	29
6.7 PF-1 Flashing Light	30
6.8 PR-1 Transmitter	30
6.9 PEL-1 Electric Latch	30
7. Annexes	31
7.1 CE Declaration of Conformity	31

1 Warnings

Please read this instruction manual carefully before the installation of gate-automated system.

This manual is exclusively for qualified installation personnel. Powertech Electronics Inc. is not responsible for improper installation and failure to comply with local electrical and building regulations.

Keep all the components of PW320/PW330 system and this manual for further consultation.

- In this manual, please pay extra attention to the contents marked by the symbol:



- Be aware of the hazards that may exist in the procedures of installation and operation of the gate-automated system. Also, the installation must be carried out in conformity with local standards and regulations.
- If the system is correctly installed and used following all the standards and regulations, it will ensure a high degree of safety.
- Make sure that the gates works properly before installing the gate-automated system and confirm the gates are appropriate for the application.
- Do not let children operate or play with the gate-automated system.

- Do not cross the path of the gate-automated system when operating.
- Please keep all the control devices and any other pulse generator away from children to avoid the gate-automated system being activated accidentally.
- Do not make any modifications to any components except that it is mentioned in this manual.
- Do not try to manually open or close the gates before you release the gear motors.
- If there is a failure that cannot be solved and is not mentioned in this manual, please contact qualified installation personnel.
- Do not use the gate-automated system before all the procedures and instructions have been carried out and thoroughly read.
- Test the gate-automated system weekly and have qualified installation personnel to check and maintain the system at least every 6-month.
- Install warning signs (if necessary) on the both sides of the gate to warn the people in the area of potential hazards.

2 Product Description

2.1 Applications

PW320/PW330 is applied for residential automation of single or dual leaf gate. PW320/PW330 has to be operated with electricity and it's forbidden to be operated by back-up batteries for normal use. Back-up batteries are only allowed for emergent operation when there is a power failure, and the gear motors can be released by special keys to move the gate manually.

2.2 Description of the Automation

The following diagram of PW320/PW330 typical installation describes some terms and accessories of a gate automation system:

Figure 1

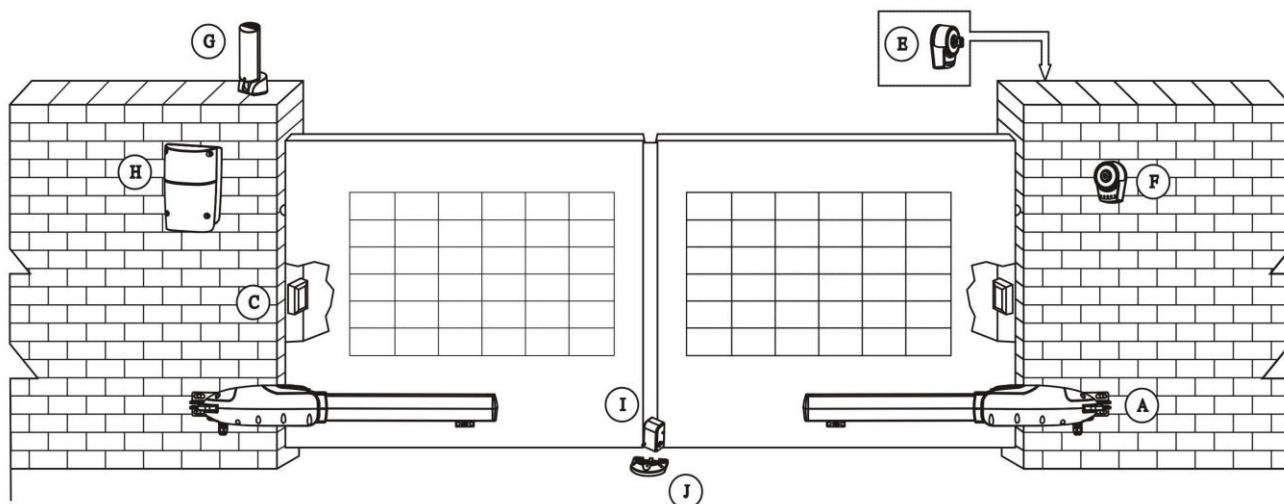

2.3 Description of Devices

PW320/PW330 includes the accessories shown in **Figure 2**. Please check the accessories the same as the package provided.

Attention: Some accessories of PW320/PW330 are not included due to local regulations or customized order.

- A) 2 PW320/PW330 electromechanical gear motors with mounting brackets.
 - B) 2 release keys.
 - C) 1 pair of PH-1 photocells.(one TX and one RX)
 - D) 2 PR-1 radio transmitters.
 - E) 1 PKS-1 key selector with two keys.
 - F) 1 PPB-1 push button switch.
 - G) 1 PF-1 flashing light.
 - H) 1 PC200 control box
 - I) 1 PEL-1 electric latch.
 - J) 1 PS-1 stopper.
 - K) Various small parts: bolts, nuts, etc.
- See **Tables 1, 2, 3, 4, 5, 6**.

Figure 2

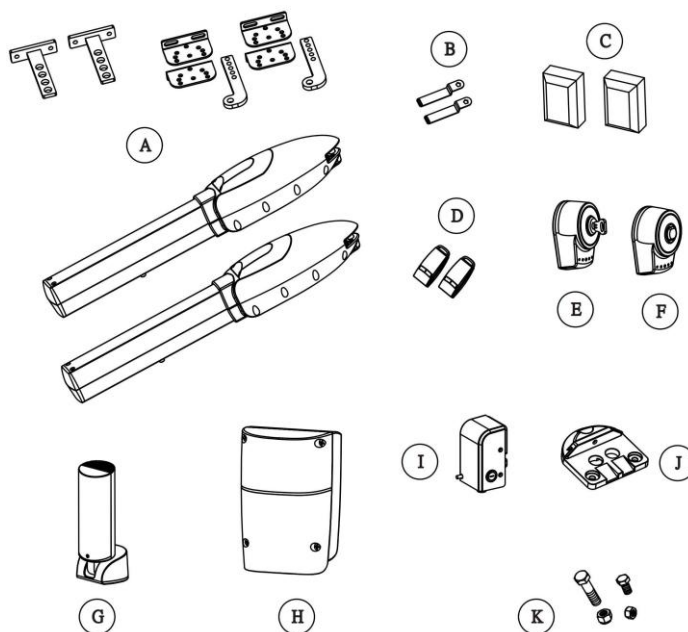

2.3.1 PW320/PW330 Electromechanical Gear Motors

PW320/PW330 consists of a worm screw reduction gear and a 24V direct current motor. The gear motor could be released manually by special release keys when there is a power failure.

The gear motor is installed with two post brackets, one rear plate and one front plate for the installation.

Table 1: List of small parts	PW320	PW330
Front plate	2pcs	2pcs
Rear plate	2pcs	2pcs
Post bracket	4pcs	4pcs
M8*25L hex bolt	4pcs	4pcs
M8 self-locking nut	4pcs	4pcs
M12 *25L hex bolt	0	2pcs
M12 self-locking nut	2pcs	2pcs
Release key	2pcs	2pcs

Figure 3

1)PW320

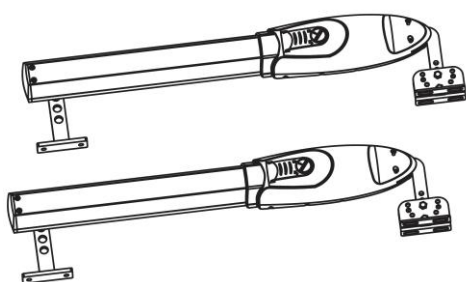

2)PW330

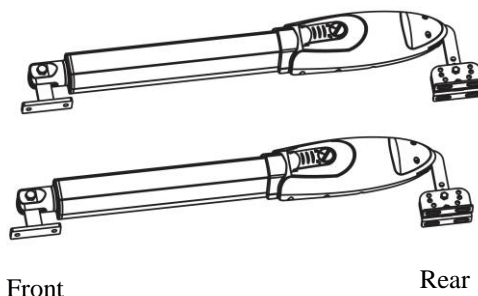

3)Release Key

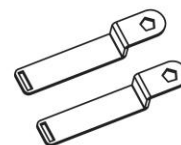

Front

Rear

2.3.2 PC200 Control Box

PC200 control box consists of one control panel with incorporated receiver, one transformer and two back-up batteries.

PC200 provides the complete automation of the gear motors and other accessories of PW320/PW330 kit.

To connect separate terminals on the control panel and activate the gear motors and other accessories, the installation manual has to be carefully read beforehand.

Figure 4

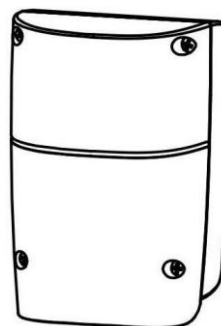

Table 2: List of small parts for PC200

	Quantity
5*30 Screw	4pcs
Nylon screw anchor	4pcs

2.3.3 PH-1 Photocells

The pair of PH-1 photocells has to be installed on the wall and connected to the control panel. The function of the photocells is to detect the obstacles found on the optical axis between the transmitter (TX) and the receiver (RX).

Figure 5

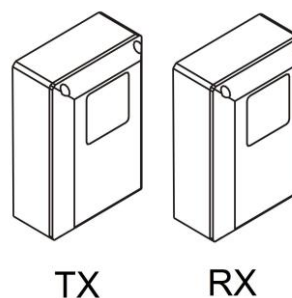

TX

RX

2.3.4 PKS-1 Key Selector

The PKS-1 key selector is used for opening the gate outdoors without the radio transmitter. PKS-1 key selector is supplied with two keys

Table 3: List of small parts for PKS-1	Quantity
3*20 Screw	3pcs
Nylon screw anchor	3pcs
Key	2pcs

Figure 6

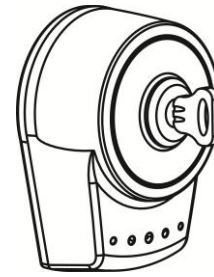

2.3.5 PPB-1 Push Button

The PPB-1 push button is used for opening the gate indoors without the radio transmitter.

Table 4: List of small parts for PPB-1	Quantity
3*20 Screw	3pcs
Nylon screw anchor	3pcs

Figure 7

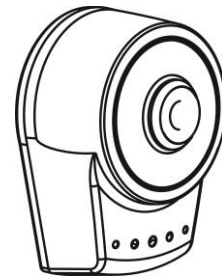

2.3.6 PF-1 Flashing Light

PF-1 flashing light is controlled by PC200 control box and blinks when the gate is moving. The flashing light stops blinking when the gates finish opening or closing.

Table 5: List of small parts for PF-1	Quantity
3*20 Screw	3pcs
Nylon screw anchor	3pcs

Figure 8

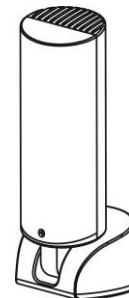

2.3.7 PR-1 Radio Transmitter

PR-1 radio transmitter is used for the remote control of the gate movement.

To use the transmitter, press and hold the button for 1 second.

There are two buttons on the transmitter for operating dual-gate (A) or single-gate (B) opening and closing.

Figure 9

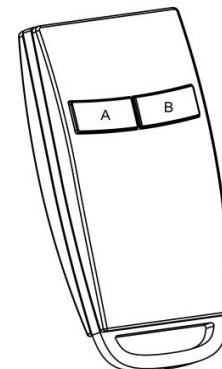

2.3.8 PEL-1 Electric Latch and PS-1 Stopper

PEL-1 electric latch is used to lock the gate and it has to be used with PS-1 stopper and installed on the master gate.

Figure 10

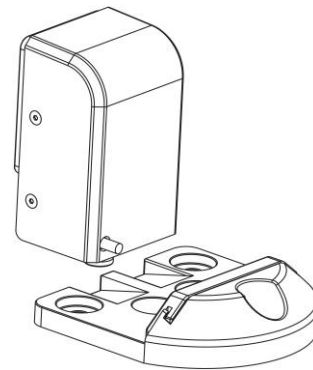

Table 6: List of small parts for PEL-1 and PS-1

	Quantity
M8*25L hex bolt	3pcs
M8 self-locking nut	3pcs
Key	2pcs

3. Installation:

3.1 Notes of Motors in Operation

The PW320/PW330 gate openers are applicable to per leaf of 3.0/4.0 meters in width and 250/350 kg in weight which can be opened up to 120 degrees primarily for residential use; where the performance shall be influenced by the factors such as gate dimension, weight and climate that the driven torque is necessarily to be adjusted properly.

3.1.1 Tools in Installing

Please make sure all tools and cables are ready and conform to the industrial safety standard before installation. Please refer to **Figure 11**.

Figure 11

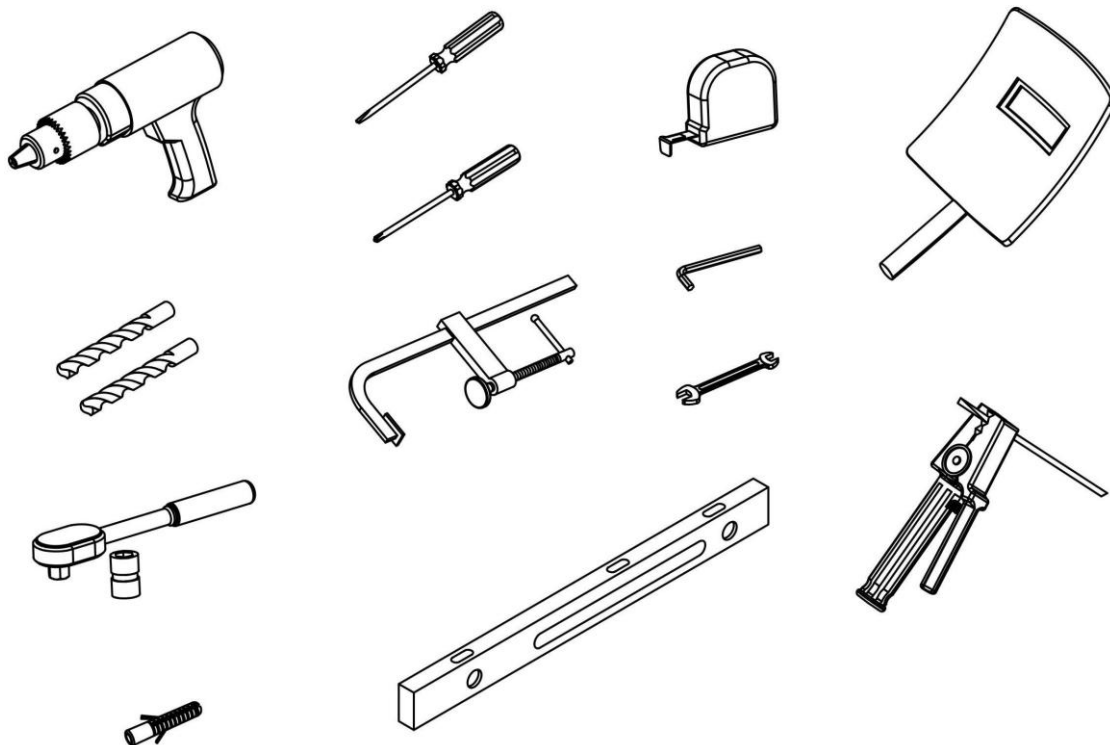

3.1.2 Motors, Components and Its Installation in Illustration

The installation procedure of PW320/PW330 may be changed due to various accessories and quantities installed. The basic wiring diagram is shown in **Figure 12**.

No wiring cables for accessories are supplied with KIT PW320/PW330.

Figure 12

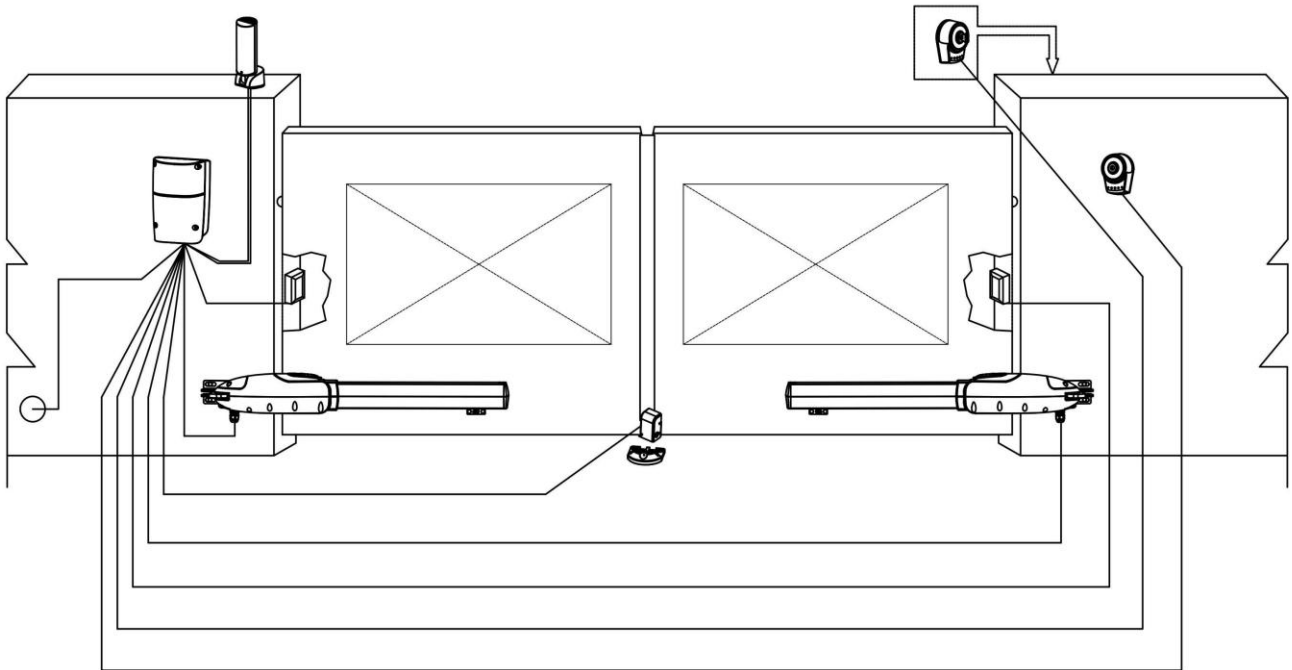

3.2 Power Connection

PW320/PW330 comes with two power cables of 2m and 7m long, which requires very low voltage that no professionally trained personnel is required in installation; however, the users are advised to read the installation manual carefully before going for it. After getting to know all accessories and their positions, suggest starting from cable conduit arrangement to prevent the cables from being broken or damaged.

3.2.1 Notes for Power Connection

1. The installation of power supply cable to the motor should be carried out by a qualified professional electrician.
2. The power supply cable of the motor should be equipped with short circuit protection and leakage protection. Please make sure to shut off the power before going installation or maintenance.

3.3 Installation

3.3.1 Preparation for Motor Installation

PW320/PW330 is not applicable to a gate which is inefficient or unsafe, neither to solve the defects due to incorrect installation nor poor maintenance.

Check the following items before going for installation:

1. Make sure the weight and dimensions of the gate conform to the operation range of PW320/PW330. Don't use PW320/PW330 if the gate specifications do not meet the requirements.
2. Make sure the gate structure conform to the criteria of automatic operation and force regulations.
3. Make sure there is no serious friction existing in the opening or closing travel of the gate leaves.
4. Make sure the gate is at horizontal level that the gate will not move aside at any position.
5. Make sure the gate can bear the impact of the motor torque when it is installed on any hole of the bracket which the surface is sufficiently sturdy.
6. Make sure the photo sensors are installed on flat surfaces to ensure the two ends of receiving and transmitting corresponded to each other.
7. Check the dimensions of the motors as below.

Figure 13

(1) Dimension of PW320

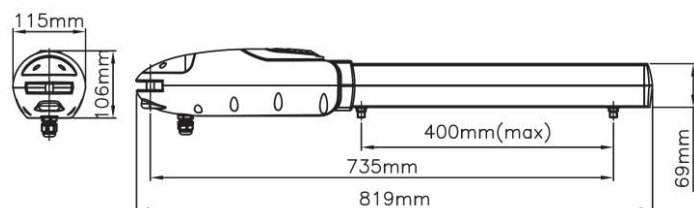

(2) Dimension of PW330

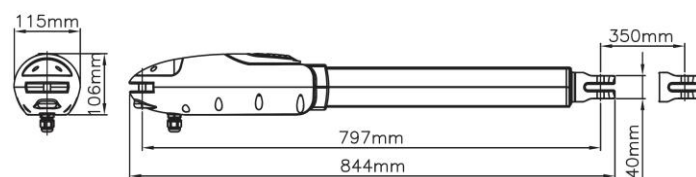

8. Make sure to leave enough space when the gate is opening.

Figure 14 (aerial view)

(1)PW320

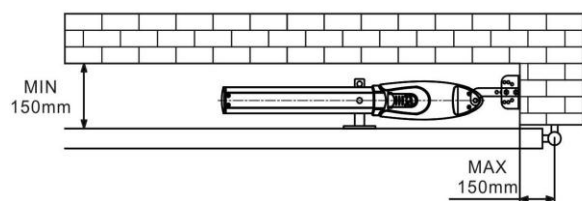

(2)PW330

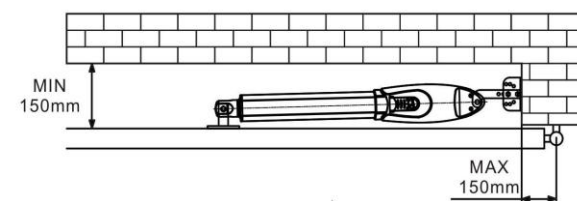

9. If the gate is **OPENED OUTWARD**, please leave at least 70mm between the post brackets and the gate.

Figure 15 (aerial view)

(1)PW320

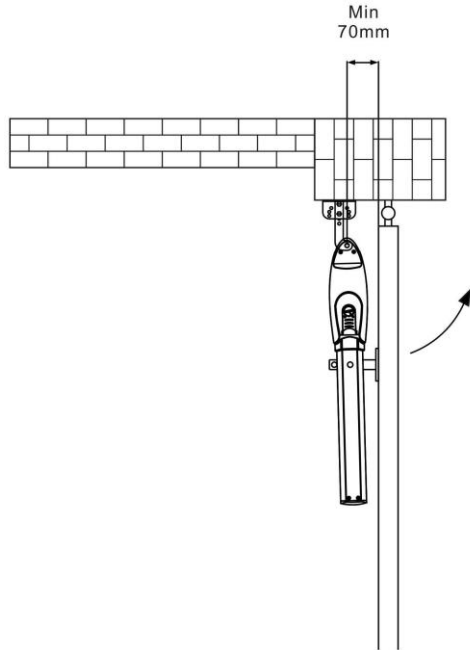

(2)PW330

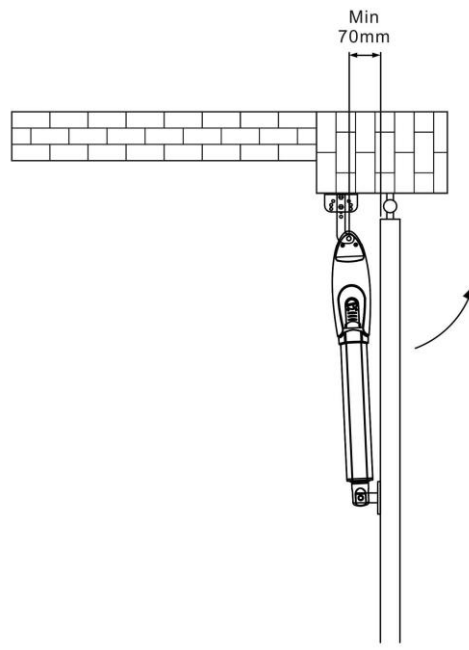

10. Using the leaf-opening angle as criteria to make sure all criteria in **Figure 17** can be met.

Figure 16 (aerial view)

(1) PW320

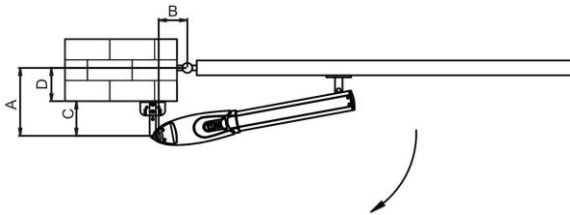

(2) PW330

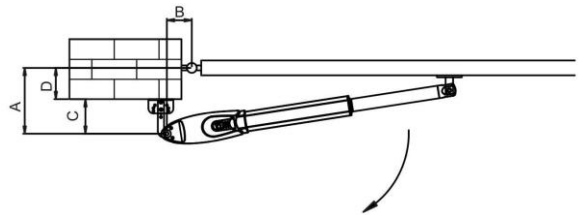
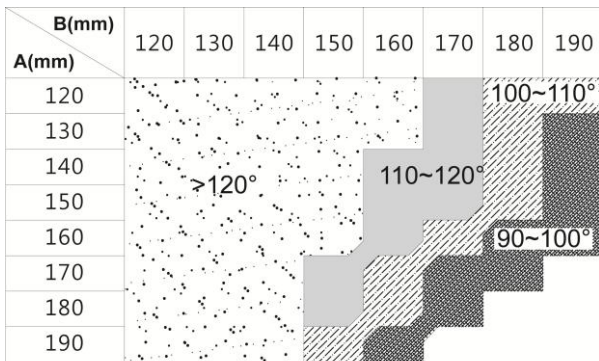

Figure 17

(1) PW320



Model:PW320

(2) PW330

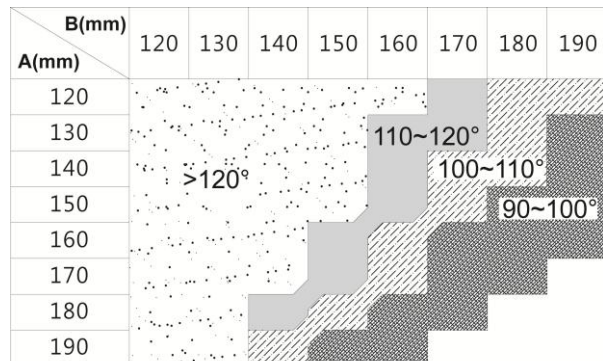

Model:PW330

11. "C" value is 139mm.
12. "D" can be measured from the gate easily.
13. "A" = "C" + "D"
14. The value of "B" can be calculated from the value of "A" and the leaves opening angle. Ex. If "A"=160mm with the leaves opening angle of 100 degrees, then the value of "B" is approximate 190mm.

**Please make sure "B" and "A" are similar or the same in value that the leaves can be operated smoothly, also to reduce the burden of the motor.

3.3.2 Installation of The Gear Motors

1. Choose the correct dimensions of the motors and position to be installed.
2. Check if the mounting surface the brackets to be installed is smooth, vertical and rigid.
3. Arrange the cable conduit for power supply cable of the motors.
4. In order to obtain the optimal supporting from the rear plate, please assemble two post brackets and one rear metal plate according to **Figure 18**.

Figure 18

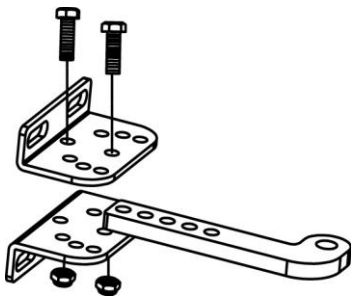

5. Loosen the two screws and remove the back cover of the motor as shown in **Figure 19**.

Figure 19

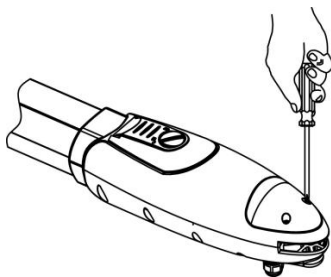

6. Place the leaves in the closed position.
7. Refer to the distance of "B" in **Figure 17**, place the rear plate in the correct position on the mounting surface. Inspect if the distance is proper as shown in **Figure 23** i.e. the position the front plate of the motor to be installed.

Figure 20

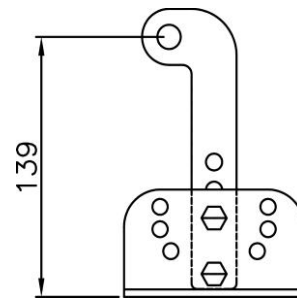

8. Place two post brackets on the surface to be installed and mark the drilling points, then drill minimum diameter of 8mm holes by four on the mounting surface to be installed and fasten up the brackets with screws and washers.

Figure 21

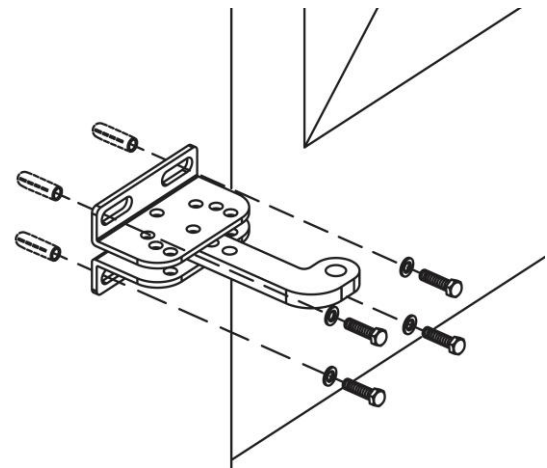

9. Please make sure the front plate is completely installed horizontally.

Figure 22

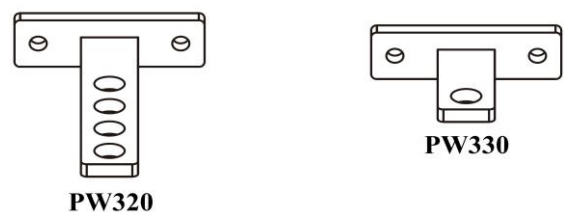

- Refer to **Figure 23**, the distance between front plate of the motor and rear plate is 735mm (PW320) / 798mm (PW330), the difference in height is 18.3mm (PW320) / 22.5mm (PW330).

Figure 23

- PW320

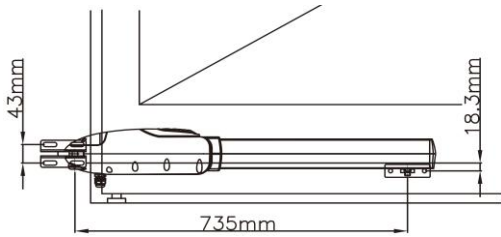

- PW330

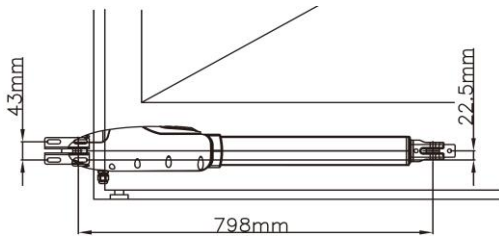

- Clamp and fix the motor front plate on the door temporarily.

Figure 24

- PW320

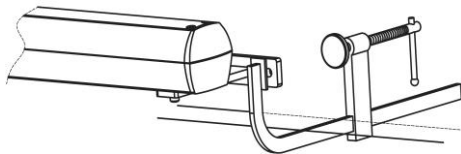

- PW330

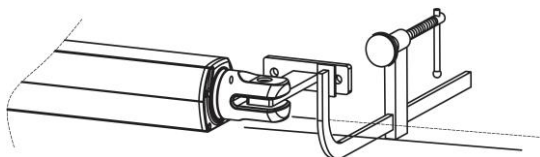

- Lift up the motor and insert the screws into the front plate.
- Lift the motor overhead and push the gate to the end until the screw holes of the motor end matches the holes on the rear plate. Fasten the motor to the rear plate with the bolt as shown in **Figure 25**.

Figure 25

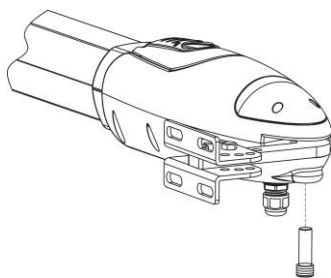

- Fasten the nut tightly and loosen it for half round for

motor supporting in rotating.

- Fasten the motor front end to the front plate with the bolt (A) and nut (B) tightly. Fully tighten the screw.

Figure 26

- PW320

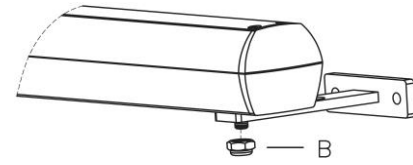

- PW330

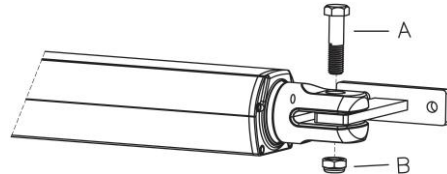

- Use appropriate release key to release the gear motor.
- Try to push the released gate and make sure the motor can be manually moved easily.
- Make sure the motor front plate can be fastened on the gate to be installed permanently.
- Use the appropriate release key to fasten the gear motor again.
- Loosen the plastic nut under the power cable of the motor end, and penetrate the power cable through the nut and screw it up.
- Connect the motor power cable as shown in **Figure 27**.

Figure 27

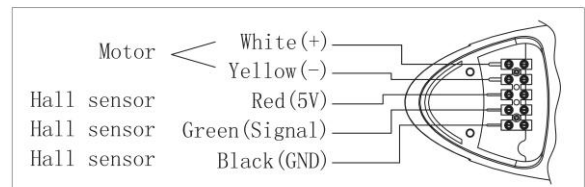

- Close the gear motor cover by tightening the two screws as shown in **Figure 28**.

Figure 28

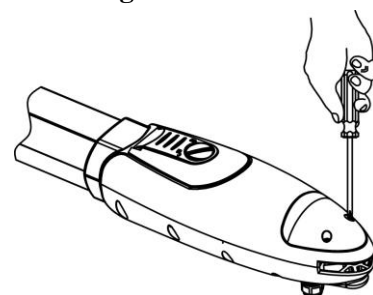

23. Gear Motor Release

- 1) Turn the round plate on the release part to "OPEN" position.

See **Figure 29**.

Figure 29

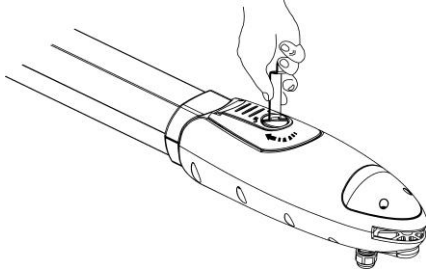

- 2) Push out the release part to the end. See **Figure 30**.

Figure 30

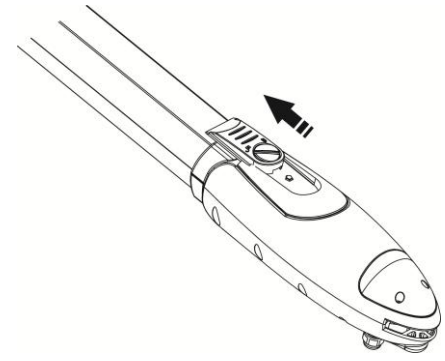

- 3) Use the release key to turn the pin anti-clockwise to the end. See **Figure 31**.

Figure 31

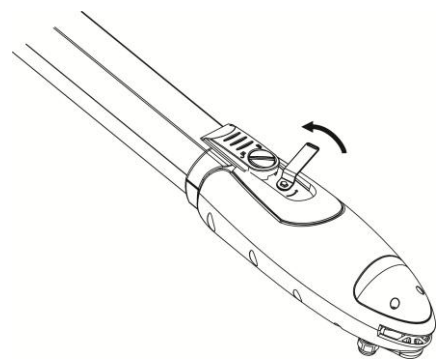

3.3.3 PKS-1 Key-Selector

1. PKS-1 key selector is installed outside and close to the gate at the height of about 100cm, so that it could be used by most people. Decide the installation position of PKS-1 first. See **Figure 3.3.3 (1)**.

Figure 3.3.3 (1)

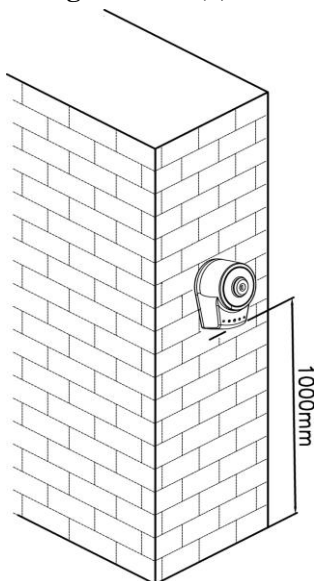

2. Remove the round cover (A) by prizing it out with the tip of a screwdriver. See **Figure 3.3.3 (2)**.

Figure 3.3.3 (2)

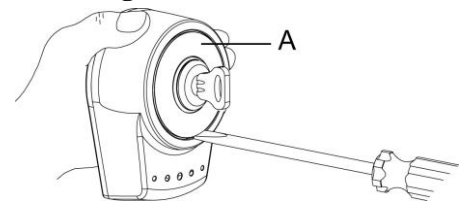

3. Unscrew the two screws beside the lock body. See **Figure 3.3.3 (3)**.

Figure 3.3.3 (3)

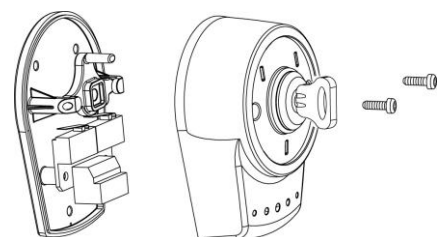

- Turn the key and separate the bottom of the shell with the lock body. See **Figure 3.3.3 (4)**.

Figure 3.3.3 (4)

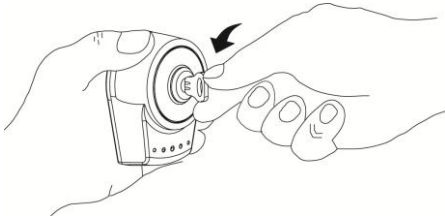

- Breach the three holes at the bottom and mark the points by the holes as reference.
- Drill the holes in the wall and fix the bottom to the wall by three screws. See **Figure 3.3.3 (5)**.

Figure 3.3.3 (5)

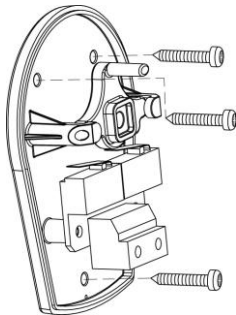

- Connect the electric wires to the terminals as shown in **Figure 3.3.3(6)**, and it's not required to distinguish any polarity. The terminals can be removed for connecting the wires easily.

Figure 3.3.3 (6)

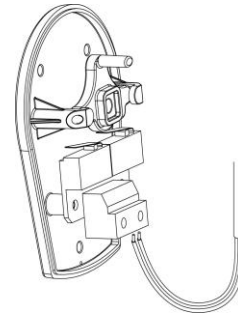

- Turn the key and insert the shell on the bottom. Turn the key back to the center position and the shell will be fixed to the bottom.
- Tighten the lock body with the two screws and insert the round cover by pressing it to attach to the whole unit.

3.3.4 PPB-1 Push Button

- PPB-1 push button is installed indoors at the height of about 100cm, so that it could be used by most people.
- Remove the round cover (A) by prizing it out with the tip of a screwdriver. See **Figure 3.3.4 (1)**.

Figure 3.3.4 (1)

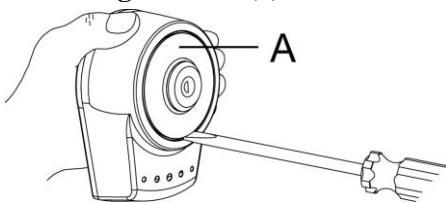

- Unscrew the two screws beside the button.

Figure 3.3.4 (2)

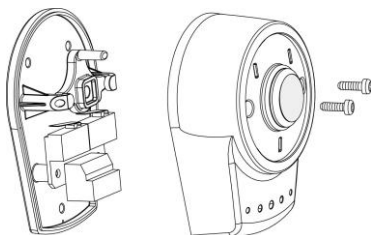

- Separate the upper shell with the bottom. See **Figure**

3.3.4 (2).

- Breach the three holes at the bottom and mark the points by the holes as reference.
- Drill the holes in the wall and fix the bottom to the wall by three screws. See **Figure 3.3.4 (3)**.

Figure 3.3.4 (3)

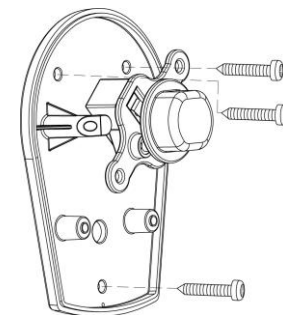

- Connect the electric wires to the terminals as shown in

Figure 3.3.4 (4), and it's not required to distinguish any polarity. The terminals can be removed for connecting the wires easily.

Figure 3.3.4 (4)

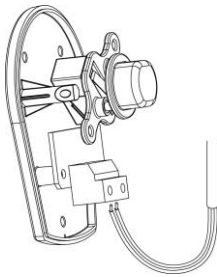

- Attach the upper shell to the bottom and screw them up by two screws and insert the round cover by pressing it to attach to the whole unit.

3.3.5 PF-1 Flashing Light

- Decide the installation position of the flashing light. The flashing light has to be installed near the gate and easy to be seen by users and passersby. The flashing light can be installed horizontally or vertically. See **Figure 3.3.5 (1)**.

Figure 3.3.5 (1)

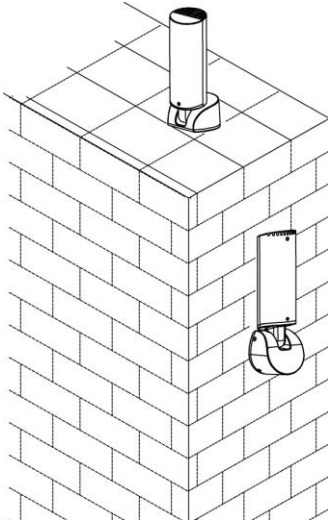
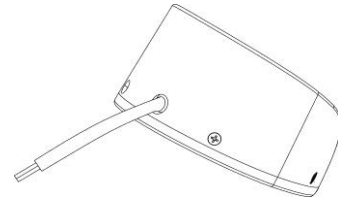
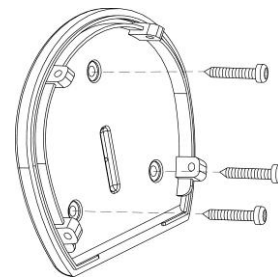

Figure 3.3.5 (3)



- Drill the holes in the wall and fix the bottom to the wall by three screws.

Figure 3.3.5 (4)



- Connect the four wires of the light and the antenna to the PCB terminals and place the wires into the conduit if necessary.

- Unscrew the four screws on the light base and separate the base with the bottom as shown in **Figure 3.3.5 (2)**.

Figure 3.3.5 (2)

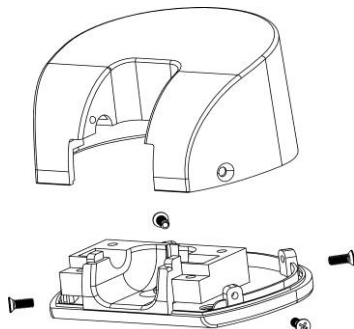
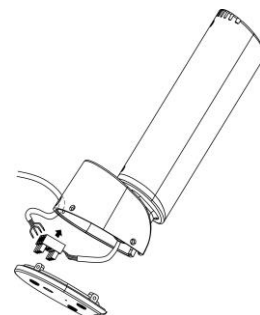

Figure 3.3.5 (5)



- Tighten the four screws back on the light base.

Figure 3.3.5 (6)

- Connect the wires and penetrate the wires into the hole of the base.

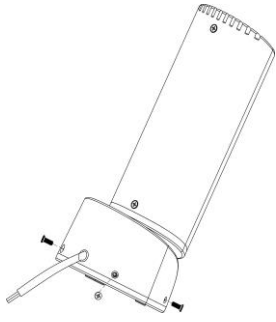

7. Replacing the bulb set. See **Figure 3.3.5 (7)**

- 1) Unscrew the flashing light wires from the PCB terminals and make sure the power of the light is off.
- 2) Release the three screws (A) · (B) · (C) of the flashing light cover.
- 3) Separate the flashing light cover and replace the bulb set with a new one.
- 4) Tighten the three screws (A) · (B) · (C) of the flashing light cover.

Figure 3.3.5 (7)

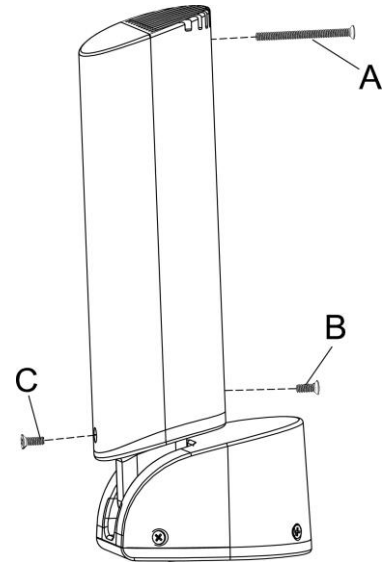

3.3.6 PH-1 Photocells

1. Decide the installation position of the photocells. See

Figure 3.3.6 (1)

Figure 3.3.6 (1)

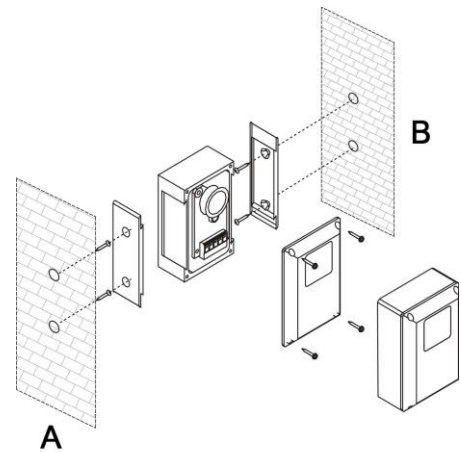
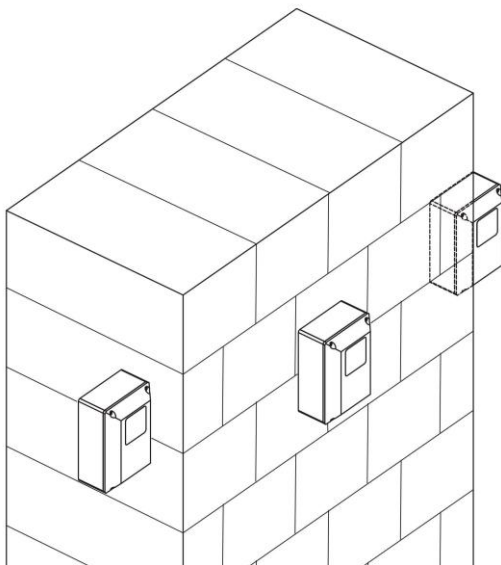
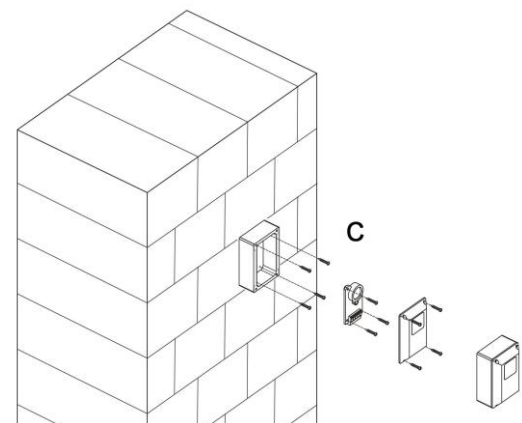

Figure 3.3.6 (3)



2. Unscrew the screws and secure the photocells on the post A, B or C.

Figure 3.3.6 (2)

3. Wiring connection:

TX: Connect terminals 1 and 2 on the transmitter with the terminals VCC and GND on the PC200 PCB.

RX: Connect terminals 1, 2 and 4 on the receiver with the terminals VCC, GND and phot1 on the PC200 PCB.

And use an extra wire to connect terminals 2 and 5 on the receiver as a bridge.

See **Figure 3.3.6 (4)** **Figure 3.3.6 (5)** and **Figure 3.3.8 (5)**

Figure 3.3.6 (4)

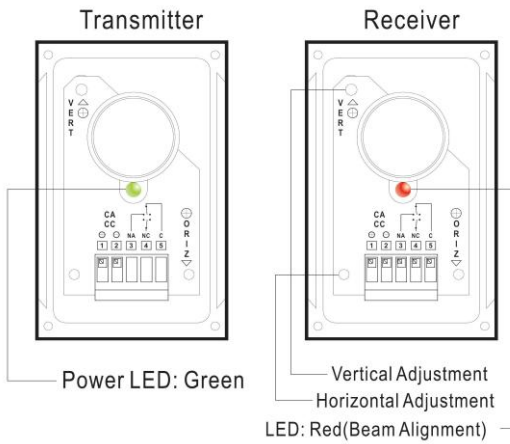
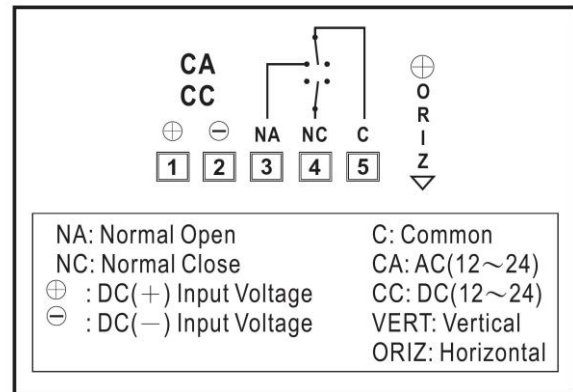

Figure 3.3.6 (5)



3.3.7 PEL-1 Electric Latch and PS-1 Stopper

1. Stopper:

- 1) Before installing the stopper, please make sure the gates are in close positions and the surface to be installed is flat.
- 2) Place the stopper on the ground using the bottom as reference, and mark the 3 drilling points.

See **Figure 3.3.7 (1)** For the gate opened **inward**.

See **Figure 3.3.7 (2)** For the gate opened **outward**.

Figure 3.3.7(1)

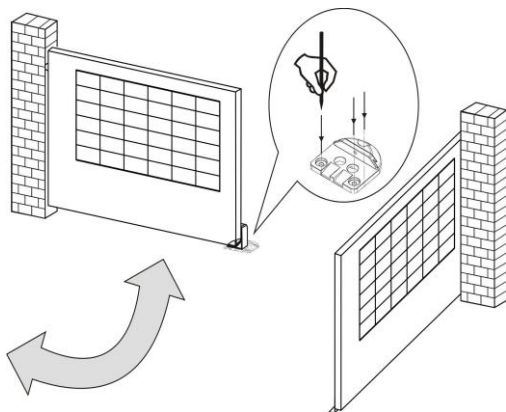

Note: If the gate is opened outward, place the stopper in opposite direction.

Figure 3.3.7(2)

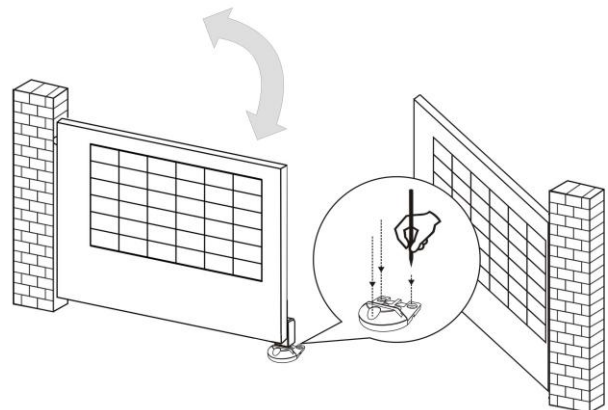

stopper to the ground with screws and washers.

See **Figure 3.3.7 (3)**

Figure3.3.7(3)

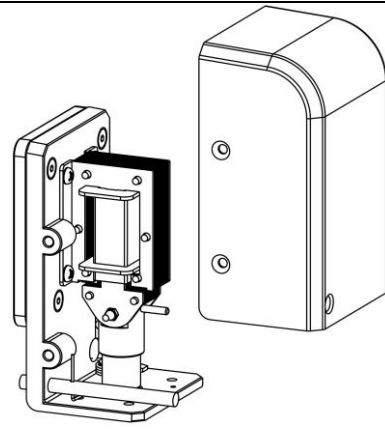
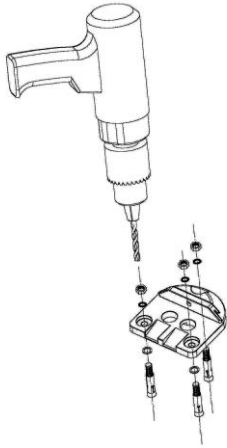

Figure3.3.7(6) The location of the spring.

2. Electric Latch:

(If the gate is opened outward)

- 1) If the gate is opened outward, please change the spring inside and screw it in the different place.

See **Figure 3.3.7 (4)**, **Figure 3.3.7 (5)**,

Figure 3.3.7 (6) & **Figure 3.3.7 (7)**

Figure3.3.7(4) Unscrew the screws.

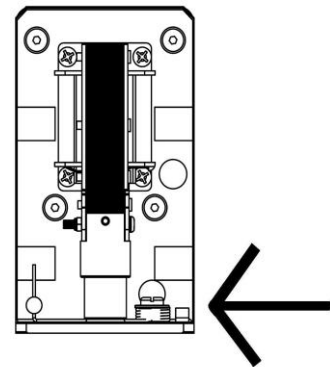
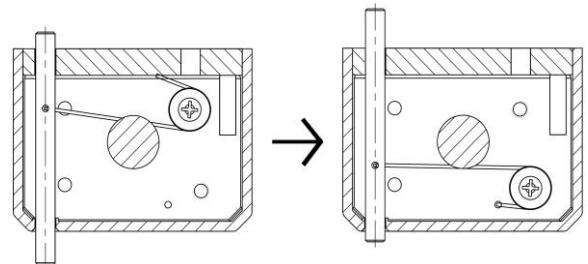
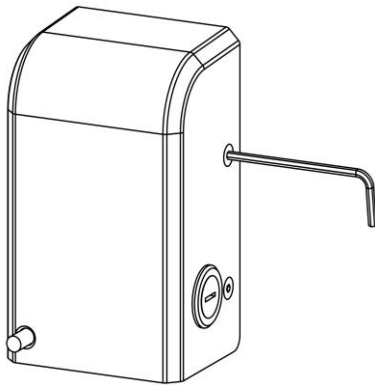

Figure3.3.7(7)

Change the spring and screw it in the different place.



(Installation)



Figure3.3.7(5) Take the casing off.

- 2) Weld the back plate of the electric latch to the surface on the master gate. See **Figure 3.3.7 (8)**. Please avoid melting the wires by the heat of the fixed

plate.

Figure3.3.7(8) For the gate opened **inward**.

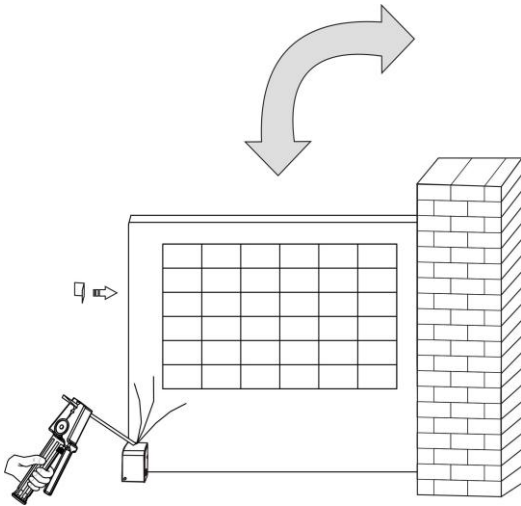
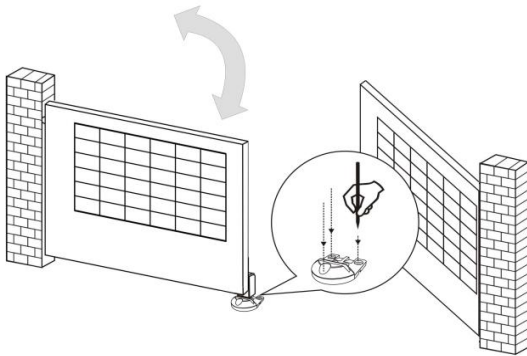

Figure3.3.7(9) For the gate opened **Outward**.



- 3) The gap between the bottom of electric latch and the stopper should be less than 7mm. See **Figure 3.3.7 (10)**

Figure3.3.7(10) For the gate opened **inward**.

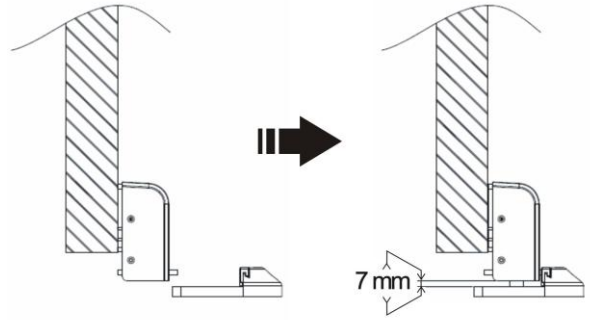
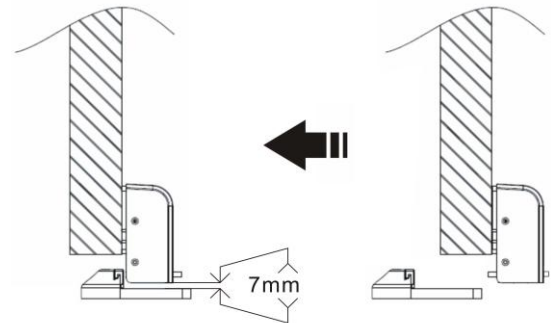

Figure3.3.7(11) For the gate opened **Outward**.



- 4) Connect the wires of the electric latch to the terminal LAT(+) and LAT(-) on the PCB.
See **Figure 3.3.8 (5)**

3.3.8 PC200 Control Box

1. Decide the installation position of PC200 control box first, it is suggested to be installed near the gate and should be protected from possible damage. Be aware of the motor cable length before deciding the installation position.
2. Remove the cover by unscrewing the four screws on the cover. See **Figure 3.3.8 (1)**.

Figure 3.3.8 (1)

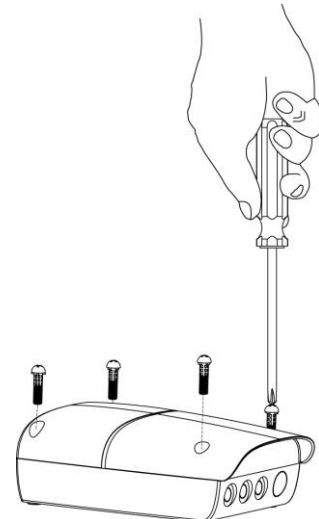

3. Use a screwdriver to puncture the holes beneath the bottom of the control box. See **Figure 3.3.8 (2)**.

Figure 3.3.8 (2)

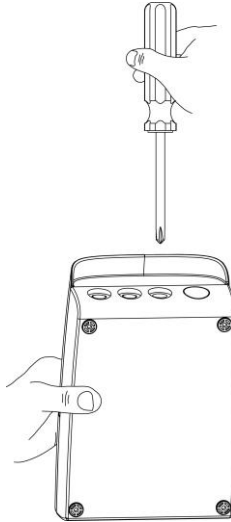

4. Secure it on the wall. See **Figure 3.3.8 (3)**.

Figure 3.3.8 (3)

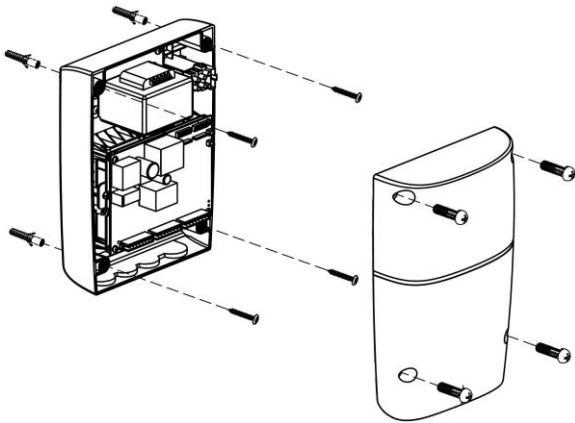

5. Wiring Connection:

Prepare all the wires of the accessories beforehand and connect the wires to the gear motors and accessories on the PCB as shown in **Figure 3.3.8 (5)**. All of the wiring connections of the accessories are not requested to distinguish the positive (+) and the negative (-) polarity.

- 1) **PF-1 Flashing light:**

Connect the two wires from the flashing light to the terminal LIT (+) and LIT (-) on the PCB.

- 2) **PEL-1 Electric Latch:**

Connect the two wires from the electric latch to the terminal LAT (+) and LAT (-) on the PCB.

- 3) **PW320/PW330 Gear Motors:**

Refer to **Figure 3.3.8 (5)** and connect the wires separately to the terminals on the PCB.

M1: Connect the motor wire (White +) to the terminals M1 (+), and (Yellow -) to the M1 (-).

Connect the hall sensor wires red, green, and black to the terminals 5V, S1, and GND.

M2: Connect the motor wire (White +) to the terminals M2 (+), and (Yellow -) to the M2 (-).

Connect the hall sensor wires red, green, and black to the terminals 5V, S2, and GND.

Notes:

For gates opened outward,

M1: Connect the motor wire (Yellow -) to the terminals M1 (+), and (White +) to the terminals M1 (-).

M2: Connect the motor wire (Yellow -) to the terminals M2 (+), and (White +) to the terminals M2 (-).

4) **PH-1 Photocells:**

See **Figure 3.3.8 (4)** and **Figure 3.3.8 (5)**

(A). In the installation of one set:

Connect the wires referred to 7 and 9.

And remove the electric jumper “**JP1**”.

(B). In the installation of two sets:

connect the wires referred to 7, 8, 9 and 10.

And remove both the electric jumper “**JP2**”and”**JP1**”.

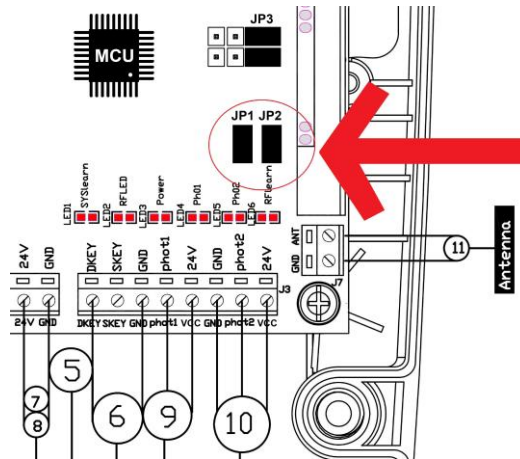

Figure 3.3.8 (4)

5) **PKS-1 Key Selector:**

For single-gate installation-

Refer to **Figure 3.3.8 (6)** and connect the two wires from the key selector to the terminal SKEY and GND on the PCB.

For dual-gate installation-

Refer to **Figure 3.3.8 (5)** and connect the two wires from the key selector to the terminal DKEY and GND on the PCB.

6) **PPB-1 Push Button:**

For single-gate installation-

Refer to **Figure 3.3.8 (6)** and connect the two wires from the push button to the terminal SKEY and GND on the PCB.

For dual-gate installation-

Refer to **Figure 3.3.8 (5)** and connect the two wires from the push button to the terminal DKEY and GND on the PCB.

Figure 3.3.8 (5)

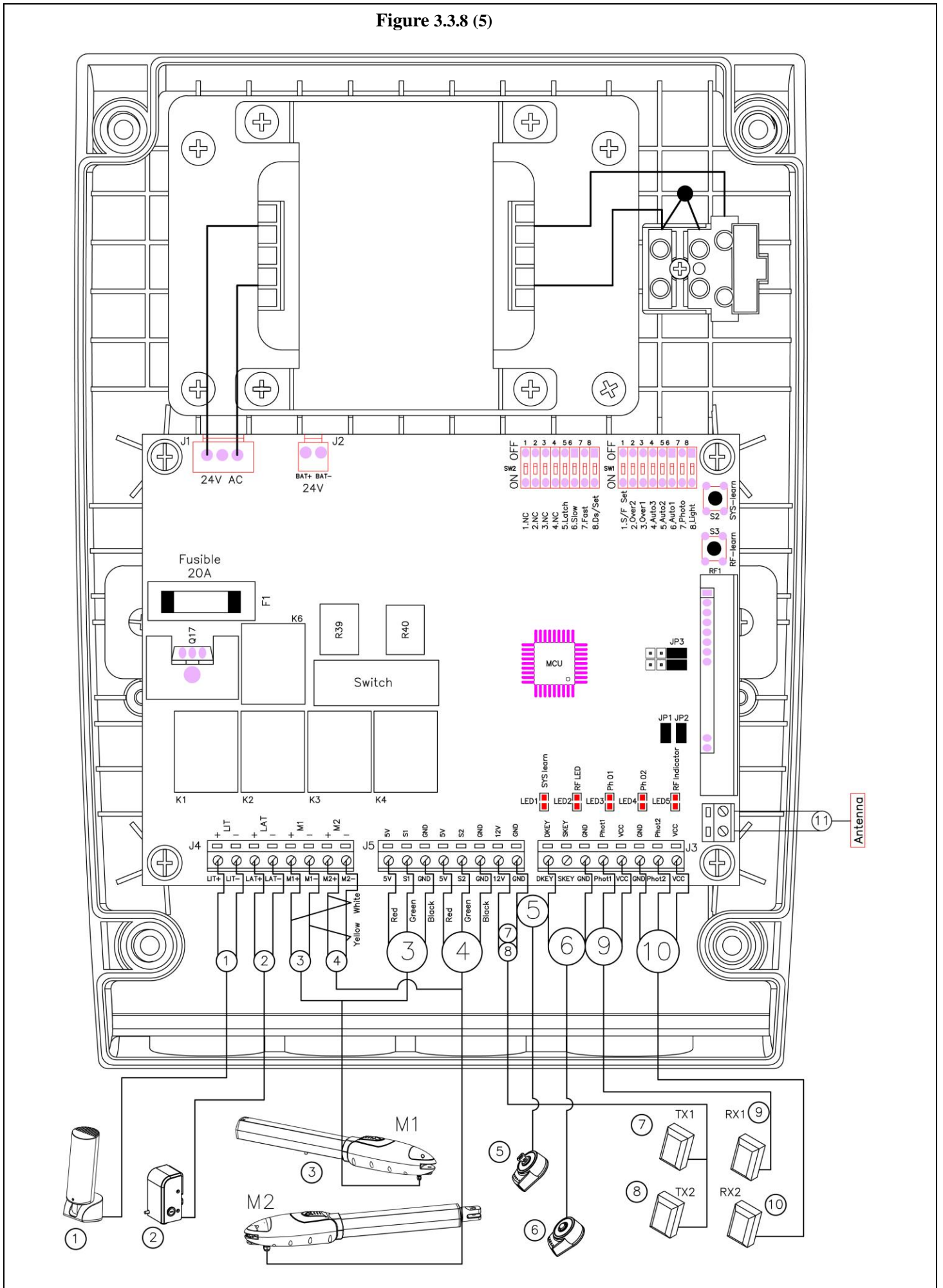
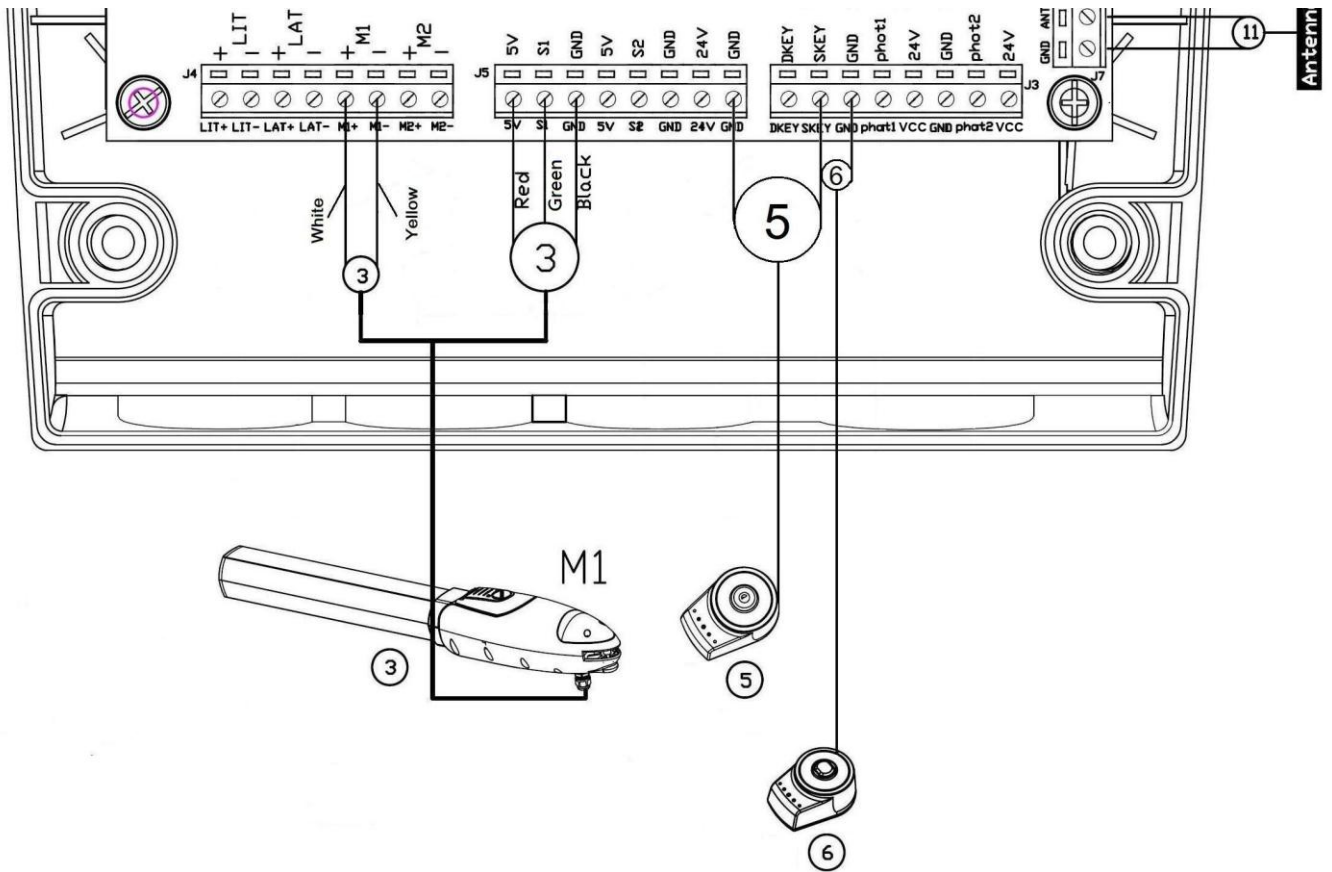

Figure 3.3.8 (6)



4. Dip Switch Setting

Before powering on the control unit, the following dip switch setting must be decided by gate weight and installation environment first. See **Figure 32**

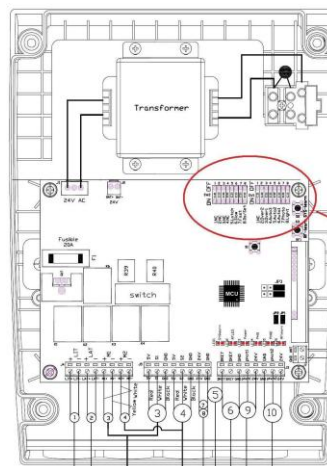
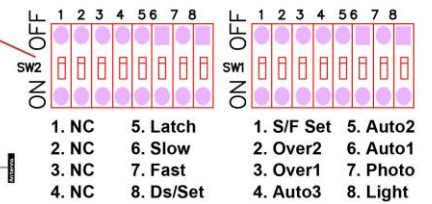

Figure 32



NC: No Connection

4.1 SW1 Dip Switch Setting

4.1.1 Slowdown Adjustment (Dip 1.S/F Set)

ON: The gear motors do not slow down before the gates completely close or open.

OFF: The gear motors slow down before the gates completely close or open.

4.1.2 Over-current Adjustment (Dip 2.Over2 & Dip 3.Over1)

OVER1	OVER2	Current (Amp)
Dip Switch 3 OFF	Dip Switch 2 OFF	2A
Dip Switch 3 ON	Dip Switch 2 OFF	3A
Dip Switch 3 OFF	Dip Switch 2 ON	4A
Dip Switch 3 ON	Dip Switch 2 ON	5A

4.1.3 Gate Auto-close Adjustment (Dip 4.Auto 3, Dip 5.Auto 2 & Dip 6.Auto 1)

Auto-close 1	Auto-close 2	Auto-close 3	Effect
Dip switch 6 OFF	Dip Switch 5 OFF	Dip Switch 4 OFF	No auto-close
Dip switch 6 ON	Dip Switch 5 OFF	Dip Switch 4 OFF	3 sec.
Dip switch 6 OFF	Dip Switch 5 ON	Dip Switch 4 OFF	10 sec.
Dip switch 6 ON	Dip Switch 5 ON	Dip Switch 4 OFF	20 sec.
Dip switch 6 OFF	Dip Switch 5 OFF	Dip Switch 4 ON	40 sec.
Dip switch 6 ON	Dip Switch 5 OFF	Dip Switch 4 ON	60 sec.
Dip switch 6 OFF	Dip Switch 5 ON	Dip Switch 4 ON	120 sec.
Dip switch 6 ON	Dip Switch 5 ON	Dip Switch 4 ON	300 sec.

Note: Auto-close mode activates when the gates move to the end position or stopped manually. If the transmitter, push button, or the key selector is activated before the auto-close counting, the gate will close immediately.

4.1.4 Photocells Adjustment (Dip 7.Photo)

ON: When encountering any obstacles, the gates will stop during opening phase ; stop and reverse to the end during closing phase.

OFF: The gate will keep moving when encountering any obstacles opening phases; stop and reverse to the end during closing phase.

4.1.5 Flashing Light Adjustment (Dip 8.Light)

ON: The flashing light blinks for 3 seconds before the gate moves, and blinks simultaneously during the movement.

OFF: The flashing light blinks and the gate moves simultaneously.

4.2 SW2 Dip Switch Setting

4.2.1 Electric Latch Adjustment (Dip 5.Latch)

ON: The electric latch functions when dip switch is set to "ON".

OFF: The electric latch does not function when dip switch is set to "OFF".

4.2.2 Slowdown Speed Adjustment of The Gear Motors (Dip 6.Slow)

ON: The speed is 70% output of the full speed.

OFF: The speed is 50% output of the full speed.

4.2.3 Operation Speed Adjustment of The Gear Motors (Dip 7.Fast)

ON: The speed is 100% output of the full speed.

OFF: The speed is 70% output of the full speed.

4.2.4 Single and Dual Gate Operation Adjustment (Dip 8.Ds/Set)

ON: Dual Gates operation in system learning and normal operation.

OFF: Single Gate operation in system learning and normal operation.

4.3 LED Indication

LED1 System Learning: LED1 blinks once

when single-gate learning is completed ; LED1 blinks

twice when dual-gate learning is completed.

LED2 RF : If the switch of the transmitter, key

selector, or the push button is activated, LED2 will be on.

LED3 Photocells 1 : LED3 will be on when the first pair of the photocells are activated.

LED4 Photocells 2 : LED4 will be on when the second pair of the photocells are activated.

LED5 RF Indicator : LED5 will be on when RF signal is received.

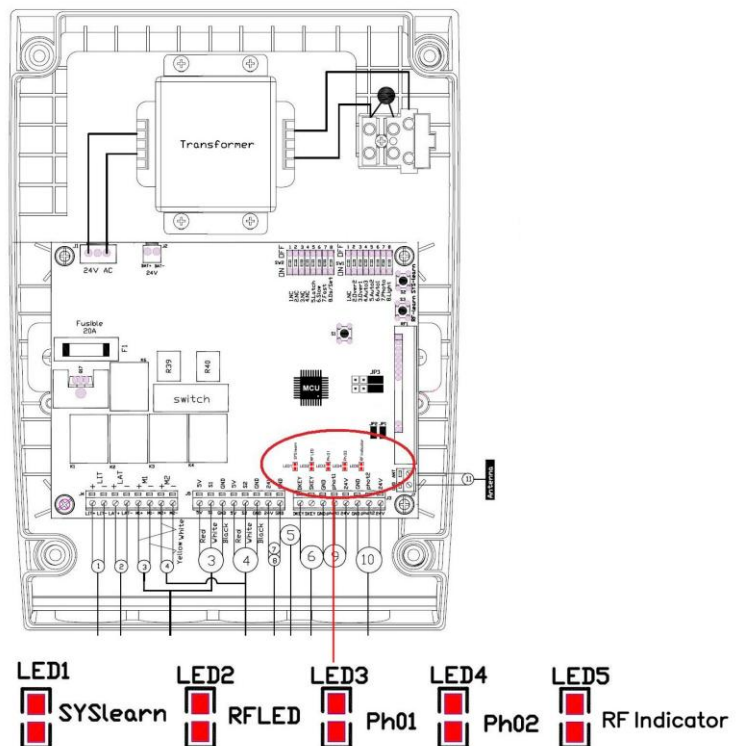

Figure 33

4.4 Transmitter Memorizing and Erasing Process

(A) Transmitter Memorizing: Press and hold the S3 button on the PCB for 1 second and then the blue LED indicator on the RF board will be “ON”. Press A button for dual-gate installation ; press B button for single-gate installation on the transmitter within 5 seconds. The transmitter learning is completed when the blue indicator is “OFF”.

(B) Transmitter Memory Erasing: Press and hold the S3 button on the PCB for three seconds.

(C) One radio receiver can be memorized with 200pcs of transmitters.

4.5 System Learning Process

Step1: Connect the master motor wires to M1 terminals and the slave motor wires to M2 terminals correctly. If only one gate is installed, the motor wires have to be connected to M1 terminals.

Step2: Press and hold the S2 button on the PCB for 5 seconds. After LED1 blinks once per second, press the button on the transmitter to choose dual-gate(A button) or single-gate(B button) system learning.

In system learning mode, the gates will proceed with the following procedures.

(A) Dual-Gate Mode: Slave Gate closes→Master Gate closes→Master Gate opens→Slave Gate opens→Slave Gate closes→Master Gate closes.

(B) Single-Gate Mode: Master Gate closes→Master Gate opens→Master Gate closes.

The completion of system learning:

(A) For Dual-Gate installation: The system learning is completed when LED1 quickly blinks twice per second.

(B) For Single-Gate installation: The system learning is completed when LED1 quickly blinks once per second.

Notes:

(A) System learning fails and needs to be learned again when an unpredictable interruption occurs.

(B) Once the system learning is completed, there is no need to proceed with the learning process again when there is a power failure.

(C) The slave gate opens 3 seconds after the master gate opens and the master gate closes 3 seconds after the slave gate closes.

4.6 Gate Operation

Press the button “A” on the transmitter for dual-gate operation.

Press the button “B” on the transmitter for single-gate operation in either single-gate or dual-gate installation.

Figure 34

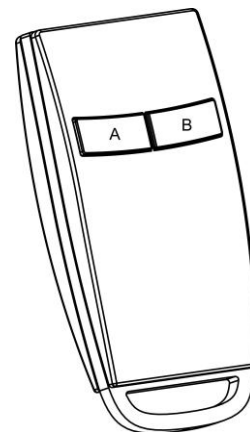

4.7 Gate-moving Logic

- (A) In gate-opening phase: The gates stop if the transmitter/push button/key selector is activated, and close when the transmitter/push button/key selector is reactivated.
- (B) In gate-closing phase: The gates stop if the transmitter/push button/key selector is activated, and open when the transmitter/push button/key selector is reactivated.
- (C) In gate-opening or gate-closing phase: For safety purpose, the gates stop if encountering obstacles.

4.8 Advanced Operation of the Transmitter

You could decide the buttons of the transmitter to operate single or double leave by adjusting the position of JP3 jumpers.

See the following description:

D_k	C	D_k	A
D	S_k	B	S_k

For two channel transmitter, there are two adjustments:

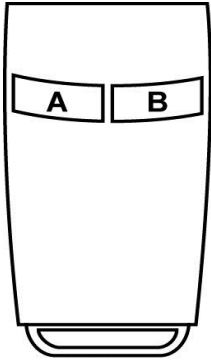

PR-1

Situation 1: AS_k: Transmitter button A for single leaf operation.

D_kB: Transmitter button B for double leaves operation.

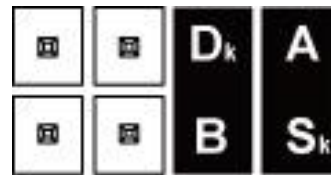

Situation 2: BS_k: Transmitter button B for single leaf operation.

D_kA: Transmitter button A for double leaves operation.



For four channel transmitter, there are four normal adjustments:

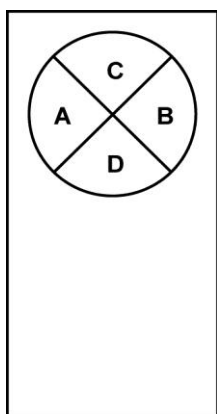

PR-2

D_k	C	D_k	A
D	S_k	B	S_k

Situation 1: AS_k: Transmitter button A for single leaf operation.

D_kB: Transmitter button B for double leaves operation.

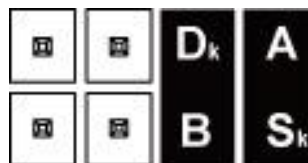

Situation 2 BS_k: Transmitter button B for single leaf operation.

D_kA: Transmitter button A for double leaves operation.

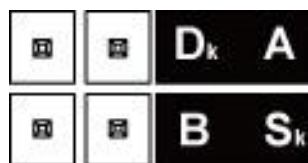

Situation 3: CS_k: Transmitter button C for single leaf operation.

D_kD: Transmitter button D for double leaves operation.



Situation 4: DS_k : Transmitter button D for single leaf operation.

D_kC Transmitter button C for double leaves operation.



5. Trouble Shooting

Overheated Back-up Batteries	Check the wiring connection of the batteries.
The gate doesn't move when pressing the button of the transmitter	<ol style="list-style-type: none"> 1. Check if LED3 or 4 is "ON". 2. Check if the voltage of the batteries is below 22V. 3. Check if LED1 is "ON". 4. Make sure all the wiring connections are firmly connected to the terminals on the PCB. 5. Make sure the fuse is workable.
The gate only moves a little distance when pressing the button of the transmitter.	Make sure the wiring connection of the hall sensor is firm.
The transmitting distance is too short	Make sure the connecting terminals of the Antenna is firm.
The gear motors run very slowly	Check the dip switch setting of the speed adjustment.
The Flashing light does not work	Check if the wiring connection of the flashing light is correct.
The leaves shall be closed instead of opening	Change the polarity connection of the positive (+) with the negative (-) of the gear motors.
The leaves suddenly stop during moving	<ol style="list-style-type: none"> 1. Check if the "RESET" socket is activated. 2. Make sure the wiring connection of the gear motors is firm. 3. Make sure the hall sensor wiring connection is firm. 4. The GND terminal of the photocells on the PCB must be short-circuited if no photocells installed. 5. Make sure the fuse is workable.
The leaves does not move or only move toward one direction	<ol style="list-style-type: none"> 1. Check if the "RESET" socket is activated. 2. Make sure the wiring connection of the gear motors is firm. 3. Make sure the hall sensor wiring connection is firm. 4. The GND terminal of the photocells on the PCB must be short-circuited if no photocells installed.
The master gate closes to the end first and the slave gate stops, the flashing light blinks fast for five seconds.	Cut off the AC input power and the output of the batteries. Release the master gate and slave gate manually, then open the master to the end and close the slave gate to the end by hand, then power the whole unit by connecting the AC and battery terminals.
The gear motors does not run and the relay is noisy when operating the gate opening and closing	Check if the fuse is burned.

6. Technical Characteristics

6.1 PW320

Motor	24Vdc motor with mechanical release
Gear type	Worm gear
Max Absorbed Power	144W
Peak thrust	3000N
Nominal thrust	2500N
Stroke length	356mm with mechanical stop/400mm without mechanical stop.
Power supply	24Vdc
Nominal input power	2A
Maximum operating current	5.5A for maximum 10 seconds.
Maximum gate weight	250 kg per leaf
Maximum gate length	3 meters
Duty cycle	20%
Operating Temperature	-20°C ~+50°C
Dimension	819mm * 115mm * 106mm
Weight	6.0kg

6.2 PW330

Motor	24Vdc motor with mechanical release
Gear type	Worm gear
Max Absorbed Power	144W
Peak thrust	3500N
Nominal thrust	3000N
Stroke length	350mm
Power supply	24Vdc
Nominal input power	2A
Maximum operating current	5.5A for maximum 10 seconds.
Maximum gate weight	350 kg per leaf
Maximum gate length	4 meters
Duty cycle	20%
Operating Temperature	-20°C ~+50°C
Dimension	844mm * 115mm * 106mm
Weight	6.25kg

6.3 PC200 Control Box

Application	For PW320/PW330 power supply
Main power supply	230Vac/110Vac, 50Hz/60Hz
Back-up battery	2pcs of batteries for emergency operation, 1.2A each
Transformer	6A, 24V
Receiver board	433.92MHz; 200 transmitters memory
Installation	Wall mounted vertically
Operating Temperature	-20°C ~+50°C
Dimension	275mm * 195mm * 102mm

6.4 PH-1 Photocells

Detection type	Through beam
Operating distance	30 meters
Response time	100ms
Input voltage	AC/DC 12~24V
Operating Temperature	-20°C ~+60°C
Protection class	IP66
Dimension	59mm * 87mm * 38mm

6.5 PKS-1 Key Selector

Application	For outdoor use
Installation	Wall mounted vertically
Operating Temperature	-20°C ~+50°C
Dimension	85mm*60.5mm*40.5mm

6.6 PPB-1 Push Button

Application	For indoor use
Installation	Wall mounted vertically
Operating Temperature	-20°C ~+50°C
Dimension	85mm*60.5mm*40.0mm

6.7 PF-1 Flashing Light

Application	For warning purpose during leaves movement
Lamp	24Vdc Halogens bulb
Operating Temperature	-20°C ~+50°C
Installation	horizontally or vertically installed
Dimension	205mm * 80mm * 75mm

6.8 PR-1 Transmitter

Application	Radio transmitter for remote control of PW320/PW330
Frequency	433.92Mhz
Coding	Rolling code
Buttons	2, for single-gate or dual-gate operation
Power Supply	6V with two CR2016 type lithium batteries
Operating Temperature	-20°C ~+50°C
Dimension	71.5mm * 33mm * 14mm

6.9 PEL-1 Electric Latch

Application	For locking the gate.
Power Supply	24Vdc
Operating Temperature	-20°C ~+50°C
Operating Current	5A
Dimension	61mm * 55mm * 120mm

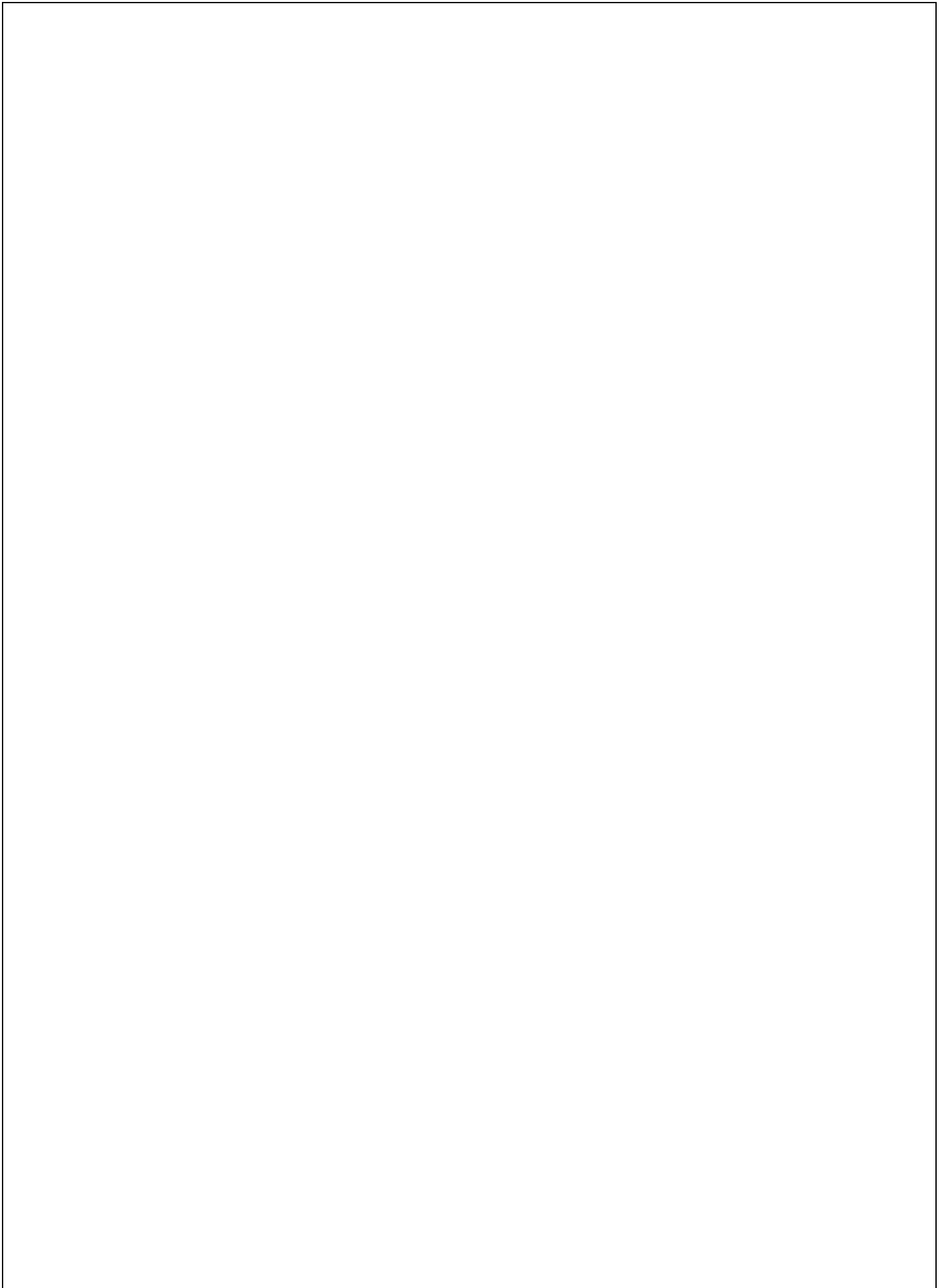



1095 Budapest, Mester u. 34.

Tel.: *218-5542, 215-9771, 215-7550,
216-7017, 216-7018 Fax: 218-5542
Mobil: 30 940-1970, 20 949-2688

1141 Budapest, Fogarasi út 77.

Tel.: *220-7940, 220-7814, 220-7959,
220-8881, 364-3428 Fax: 220-7940
Mobil: 30 531-5454, 30 939-9989

E-mail: delton@delton.hu Web: www.delton.hu

www.kaputnyitunk.hu

34100-046



POWERTECH

THE STRONGEST SOLUTION
FOR SWING GATES

- Worm gear provides durability and silence in motor operation.
- Slowdown during opening and closing phase.