

MhouseKit GD0

For the automation of a sectional or overhead door.

CE



Installation instructions and warnings

mhouse
4

CONTENTS

WARNINGS

STEP 1	4
---------------	---

PRODUCT DESCRIPTION

STEP 2	5
2.1 - Applications	5
2.2 - Description of the automation	5
2.3 - Description of devices	5
- 2.3.1 - GD0K Electromechanical Gearmotor	6
- 2.3.2 - PH0 photocells (optional)	6
- 2.3.3 - KS1 key-operated selector switch (optional)	7
- 2.3.4 - FL1 flashing light with incorporated aerial (optional)	7
- 2.3.5 - TX4 radio transmitter	7

INSTALLATION

STEP 3	7
3.1 - Preliminary checks	7
- 3.1.1 - Operating limits	9
- 3.1.2 - Tools and Materials	9
- 3.1.3 - List of cables	10
3.2 - Preparing the Electrical System	10
- 3.2.1 - Connection to the Electrical Mains	10
3.3 - Installation of the Various Devices	11
- 3.3.1 - Guide assembly	11
- 3.3.2 - Fixing of the gearmotor to the guide	11
- 3.3.3 - Fixing of the gearmotor to the ceiling	12
- 3.3.4 - Power Supply Connection	13
- 3.3.5 - KS1 key-operated selector switch (optional)	14
- 3.3.6 - FL1 flashing light (optional)	14
- 3.3.7 - Electrical connections to the GD0K control unit	15
3.4 - Power Supply Connection	16
3.5 - Initial checks	16
- 3.5.1 - Recognition of the door's open and closed positions	17
- 3.5.2 - Testing the radio transmitter	17
3.6 - Regulations	17
- 3.6.1 - Selecting door speed	17
- 3.6.2 - Selecting the type of operating cycle	17
3.7 - Testing and Commissioning	18
- 3.7.1 - Testing	18
- 3.7.2 - Commissioning	18

MAINTENANCE

STEP 4	18
---------------	----

PRODUCT DISPOSAL	18
-------------------------	----

ADDITIONAL INFORMATION

STEP 5	19
5.1 - Advanced Adjustments	19
- 5.1.1 - Adjusting the Parameters with the Radio Transmitter	19
- 5.1.2 - Checking the Adjustments with the Radio Transmitter	19
5.2 - Optional Accessories	19
5.3 - Adding or Removing Devices	20
- 5.3.1 - Phototest output	20
- 5.3.2 - STOP Input	20
5.4 - Memorization of Radio Transmitters	20
- 5.4.1 - Memorization Mode 1	20
- 5.4.2 - Memorization Mode 2	21
- 5.4.3 - Remote memorization	21
- 5.4.4 - Deleting a Radio Transmitter	21
- 5.4.5 - Deleting all the Radio Transmitters	21
5.5 - Troubleshooting	21
5.6 - Diagnostics and Signals	22
- 5.6.1 - Photocells	22
- 5.6.2 - Flashing and courtesy lights	22
- 5.6.3 - Control Unit	23

TECHNICAL CHARACTERISTICS

STEP 6	24
---------------	----

TECHNICAL DOCUMENTATION

STEP 7	I
7.1 - Operating guide	I
- 7.1.1 - Safety regulations	I
- 7.1.2 - Door Control	I
- 7.1.3 - Maintenance Operations to Be Performed by the User	I
- 7.1.4 - Replacing the Remote Control Battery	II
- 7.1.5 - Lamp replacement	II
CE Declaration of Conformity of GD0 Components	III
CE Declaration of Conformity of Power Operated Sectional or Overhead Door	IV

WARNINGS

STEP 1

Important installer and user safety instructions

• If this is the first time that you install a GD0 sectional or overhead door automation system we recommend that you dedicate some of your time to reading this manual. You should read it before you start installing the system, so you don't have to rush to finish the work.

Keep all the components of the GD0 system handy so that you can read, check and verify all the information contained in this manual. However, do not carry out the adjustment and memorization stages otherwise, during the actual installation of the products, you will have to deal with settings that differ from the original factory ones.

• When reading this manual, pay special attention to the sections marked by the following symbol:



these sections are particularly important for safety.

- Store this manual safely for future use.
- This manual, as well as the design and manufacture of the devices that make up GD0, comply fully with the standards and regulations in force.
- Considering the hazards that may exist during the installation and operation of GD0, it is necessary that also the installation be carried out in strict compliance with current legislation, standards and regulations, particularly:
 - **This manual contains important information regarding personal safety; before you start installing the components, it is important that you read and understand all the information contained herein. Do not proceed with the installation if you have doubts of any sort; if necessary, refer to the MHOUSE customer service department for clarifications.**
- Follow all installation instructions
 - **Before you start with the installation, make sure that each single GD0 device is suitable for the intended automation purposes; pay special attention to the data provided in chapter 6 "Technical Characteristics". If even a single device is not suitable for the intended application, do not proceed with the installation.**
 - **Before you start with the installation, check whether additional devices or materials are needed to complete the automation with GD0 based on the specific application requirements.**
- The GD0 automation system must not be installed outdoors
- The GD0 automation system must not be used until the automation has been commissioned as described in paragraph 3.7.2 "Commissioning".
- The GD0 automation system cannot be considered as a suitable intrusion protection system. If you require efficient protection you need to integrate GD0 with other devices.
- The packing materials for GD0 must be disposed of in compliance with local regulations.
- Do not make modifications to any components unless provided for in this manual. This type of operations will only cause malfunctions. MHOUSE disclaims any liability for damage resulting from modified products.
- Components must never be immersed in water or other liquids. Also during installation, do not allow liquids to enter the gearmotor or other open devices.

• In the event that liquid substances have penetrated inside the automation devices, immediately disconnect the power supply and contact the MHOUSE customer service department. The use of GD0 in these conditions can be dangerous.

• **Keep all components of GD0 away from heat sources and open flames; these could damage the components and cause malfunctions, fire or dangerous situations.**

• **Connect the gearmotor only to a power supply line equipped with safety grounding system.**

• **All operations requiring the opening of the protection shell of GD0 device must be performed with the gearmotor disconnected from the power supply; if the disconnection device is not identifiable, post the following sign on it: "WARNING: MAINTENANCE WORK IN PROGRESS".**

• **In the event that any automatic switches or fuses are tripped, you must identify the failure and eliminate it before you reset them.**

• **If a failure occurs that cannot be solved using the information provided in this manual, refer to the MHOUSE customer service department.**

Particular warnings concerning the suitable use of this product in relation to the "Machine Directive" 2006/42/CE :

- This product comes onto the market as a "machine component" and is therefore manufactured to be integrated to a machine or assembled with other machines in order to create "a machine", under the directive 2006/42/CE, only in combination with other components and in the manner described in the present instructions manual. As specified in the directive 2006/42/CE the use of this product is not admitted until the manufacturer of the machine on which this product is mounted has identified and declared it as conforming to the directive 2006/42/CE.

Particular warnings concerning the suitable use of this product in relation to the "Low Voltage" Directive 2006/95/CE:

- This product responds to the provisions foreseen by the "Low Voltage" Directive if used in the configurations foreseen in this instructions manual and in combination with the articles present in the Mhouse S.r.l. product catalogue. If the product is not used in configurations or is used with other products that have not been foreseen, the requirements may not be guaranteed; the use of the product is prohibited in these situations until the correspondence to the requirements foreseen by the directive have been verified by those performing the installation.

Particular warnings concerning the suitable use of this product in relation to the "Electromagnetic Compatibility" Directive 2004/108/CE:

- This product has been subjected to tests regarding the electromagnetic compatibility in the most critical of use conditions, in the configurations foreseen in this instructions manual and in combination with articles present in the Mhouse S.r.l. product catalogue. The electromagnetic compatibility may not be guaranteed if used in configurations or with other products that have not been foreseen; the use of the product is prohibited in these situations until the correspondence to the requirements foreseen by the directive have been verified by those performing the installation.

PRODUCT DESCRIPTION

STEP 2

2.1 – APPLICATIONS

GD0 is a set of components designed for the automation of sectional or overhead doors in residential applications.

Any applications other than those described above or under different conditions from those specified in this manual are forbidden.

GD0 operates with electric power. In the event of a power failure, the gearmotor can be released using a suitable cord in order to move the door manually.

2.2 – DESCRIPTION OF THE AUTOMATION

To clarify a few terms and aspects of a sectional or overhead door automation system:

In Figure 1 we provide an example of a typical GD0 application:

- A) FL1 flashing light with incorporated aerial (optional)
- B) KS1 key-operated selector switch (optional)
- C) Pair of PH0 photocells (optional)
- D) Mechanical stops
- E) GD0K gearmotor

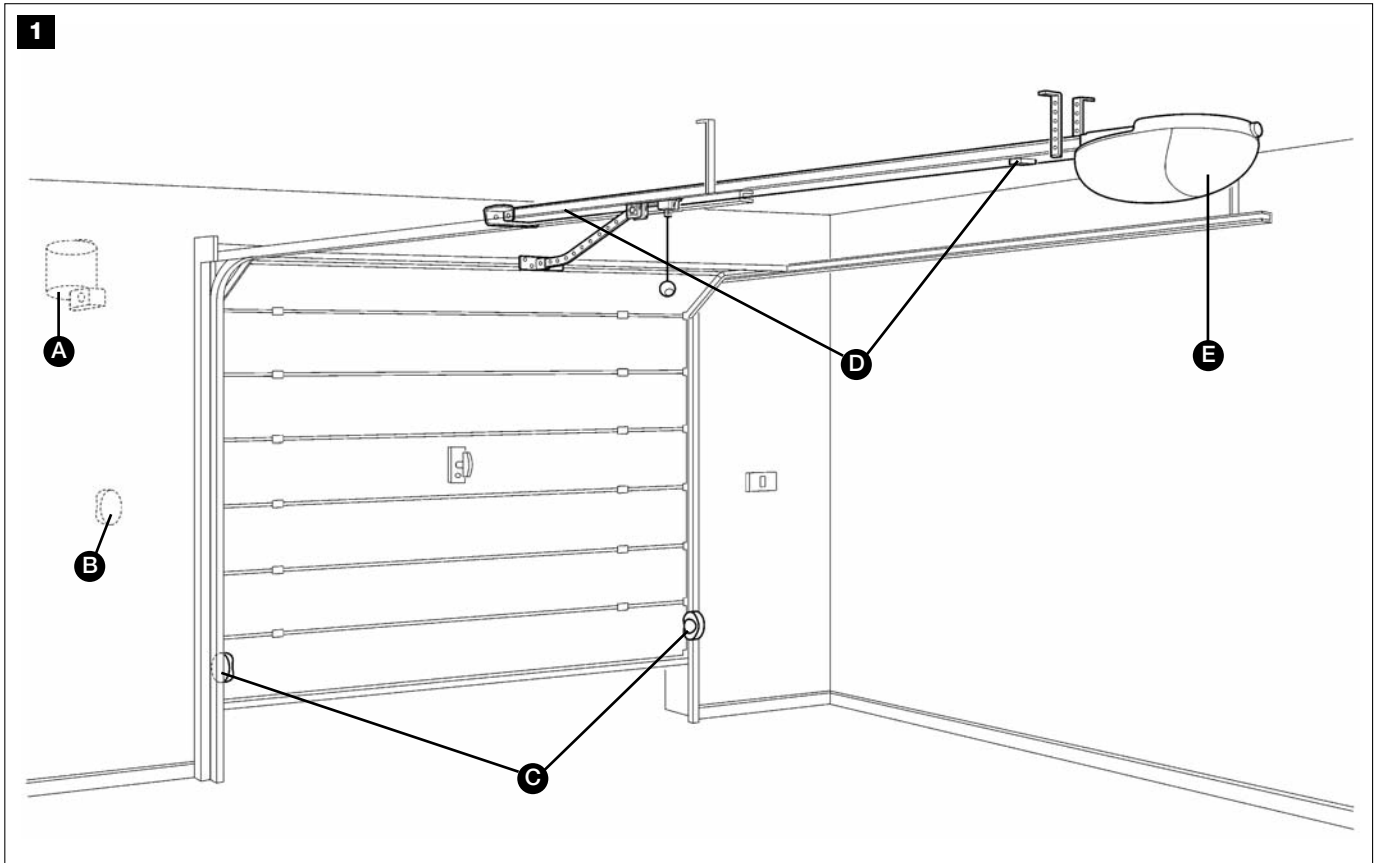

2.3 – DESCRIPTION OF DEVICES

GD0 can consist of the devices shown in figure 2; make immediately sure that they correspond to the contents of the package and verify the integrity of the devices.

Note: to adapt GD0 to local regulations, the contents of the package may vary; an exact list of the contents is shown on the outside of the package under the "Mhousekit GD0 contains" heading.

Component and accessories list:

- A) GD0K electromechanical gearmotor with incorporated control unit
- B) head with pinion
- C) carriage and release cord
- D) 6 m belt
- E) leaf bracket
- F) 3 m guide in 3 sections
- G) 2 coupling profiles
- H) 2 ceiling-mounted brackets

- I) Various small parts: mechanical stops, screws, washers, etc. See tables 1, 2, 3 and 4 (*)
- L) 1 TX4 radio transmitter
- M) PH0 pair of wall-mounted photocells
- N) KS1 key-operated selector switch
- O) FL1 flashing light with incorporated aerial.

* The screws required for mounting GD0 are not supplied as they depend on the type of material and its thickness.

2

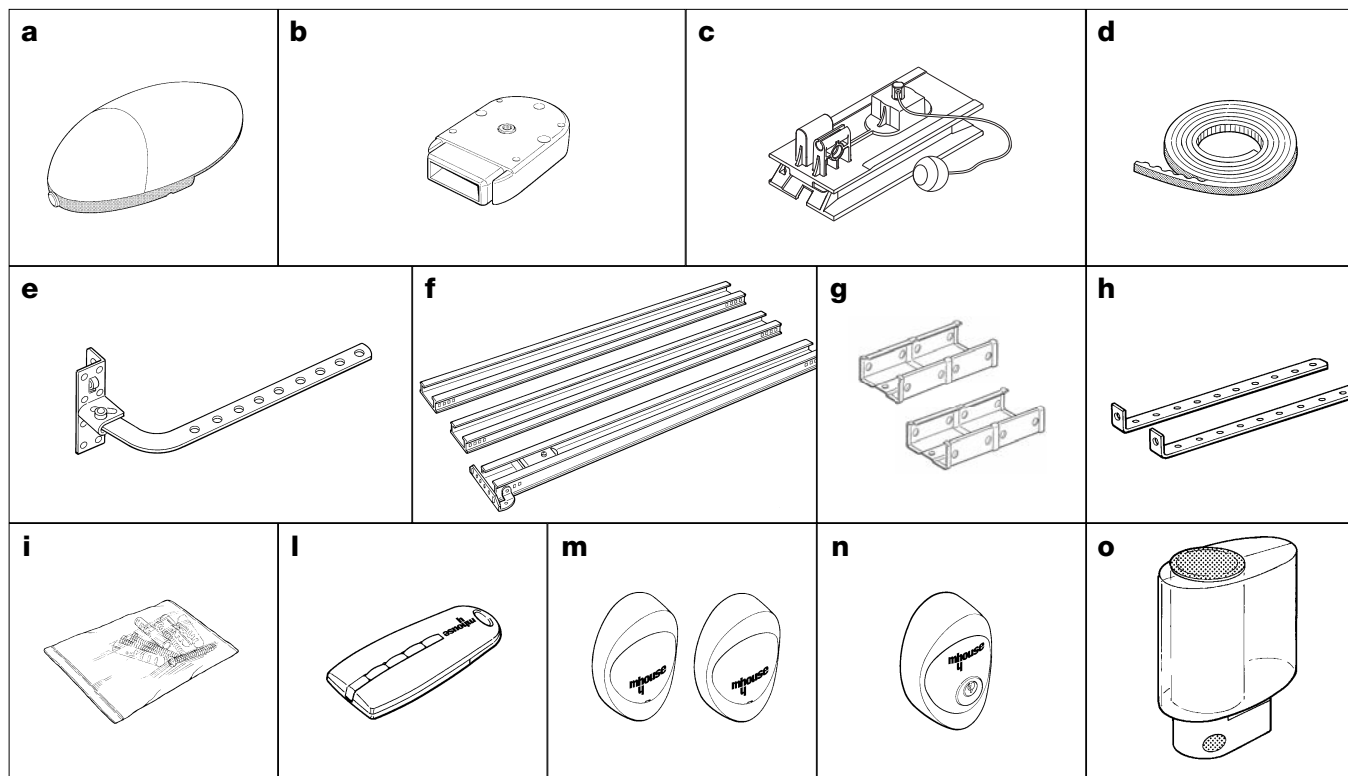

2.3.1 – GD0K Electromechanical Gearmotor

GD0K is an electromechanical gearmotor consisting of a 24V direct current motor. It features a mechanical release mechanism with cord that allows you to move the door manually in the event of a power failure.

The gearmotor is fixed to the ceiling with the relative mounting brackets.

The control unit actuates the gearmotors and provides for the control of the supply of the different components; it features an electronic board with incorporated radio receiver.

The control unit can actuate the gearmotor with two speeds: “slow” and “fast”.

The three P1, P2 and P3 buttons [B] and the corresponding LED’s are used to program the control unit.

A numbered terminal block is present for the electrical connections [A]. A LED status signal is present in correspondence with the STOP input.

The connection to the power supply is very easy: just insert the plug in a power outlet.

3

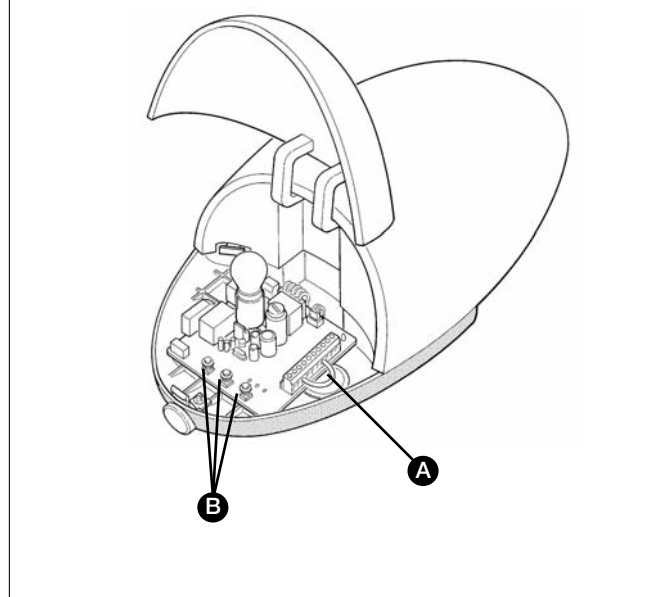

2.3.2 – PH0 photocells (optional)

The pair of PH0 wall-mounted photocells, once they are connected to the control unit, enables the detection of obstacles found on the optical axis between the transmitter (TX) and the receiver (RX).

TABLE 2

List of small parts for PH0	Q.ty
HI LO 4X9.5 screw	4 pcs
3.5X25 self-tapping screw 3,5X25	4 pcs
s 5 c nylon screw anchor	4 pcs

TABLE 1

List of small parts for a GD0K	Q.ty
M6 self-tapping nuts	4 pcs
M6 x14 screws	2 pcs
6.3x38 tcei screws	4 pcs
4.2x9.5 screws	2 pcs
6x18 screw	1 pcs
R05 washers	2 pcs
Cable membrane	1 pc
Mechanical stops	2 pcs

4

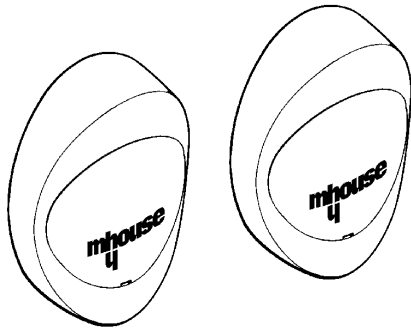

2.3.3 – KS1 key-operated selector switch (optional)

The KS1 key-operated two-position selector switch enables door control without using the radio transmitter. It is equipped with internal light for locating in the dark.

There are two commands, which depend on the direction of rotation of the key: “OPEN” and “STOP”; then the key, which is spring loaded, returns to the centre position.

TABLE 3

List of small parts for KS1	Q.ty
HI LO 4X9.5 screw	2 pcs
3.5X25 self-tapping screw	4 pcs
s 5 c nylon screw anchor	4 pcs

5

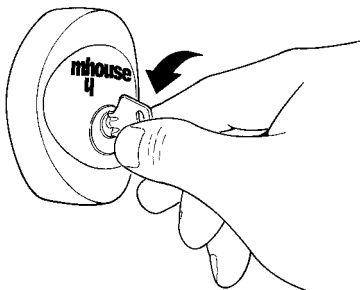

2.3.4 – FL1 flashing light with incorporated aerial (optional)

The flashing light is controlled by the control unit and signals danger when the door is moving. Inside the flashing light there is also the aerial for the radio receiver.

TABLE 4

List of small parts for FL1	Q.ty
4.2X32 self-tapping screw	4 pcs
s 6 c nylon screw anchor	4 pcs

6

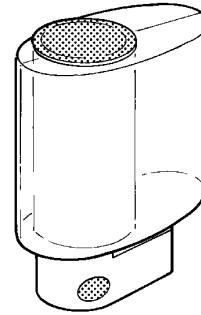

2.3.5 – TX4 radio transmitter

The radio transmitter is used for the remote control of the door opening and closing manoeuvres. It features four buttons that can all be used for the 4 types of command to a single automation unit, or to control up to 4 different automation units.

The transmission of the command is confirmed by the LED [A]; an eyelet [B] allows them to be hung on a keyring.

7

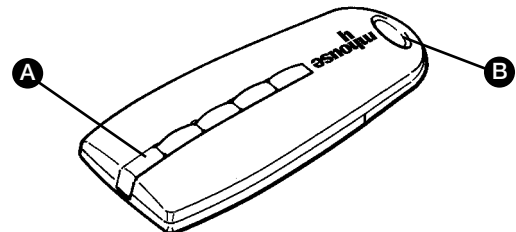

INSTALLATION

STEP 3

⚠ The installation must be carried out by qualified and skilled personnel in compliance with the directions provided in chapter 1 “WARNINGS”.

3.1 – PRELIMINARY CHECKS

GD0 must not be used to power a door that is not efficient and safe. It cannot solve defects resulting from incorrect installation or poor maintenance of the door.

WARNING: incorrect installation could cause serious damage.

Before proceeding with the installation you must:

- Make sure that the door movement does not hinder roads or public footpaths.
- After the motor has been installed, remove unnecessary cables or chains and turn off any unneeded equipment

- Make sure that the weight and dimensions of the door fall within the specified operating limits (Chapter 3.1.1). If they do not, GD0 cannot be used.

- Make sure that the structure of the door is suitable for automation and in compliance with regulations in force.

- Make sure that there are no points of greater friction in the opening or closing travel of the door.

- Make sure that the mechanical structure of the door is sturdy enough and that there is no risk of derailing out of the guide.

- Make sure that the door is well balanced: it must not move by itself when it is placed in any position.

- Make sure that the installation area is compatible with the size of the gearmotor and that it is safe and easy to release it.

- Make sure that the mounting positions of the various devices are protected from impacts and that the mounting surfaces are sufficiently sturdy.

- Make sure that the mounting surfaces of the photocells are flat and that they enable the proper alignment between TX and RX.
- Make sure that the minimum and maximum clearances specified in fig. 8 are observed.

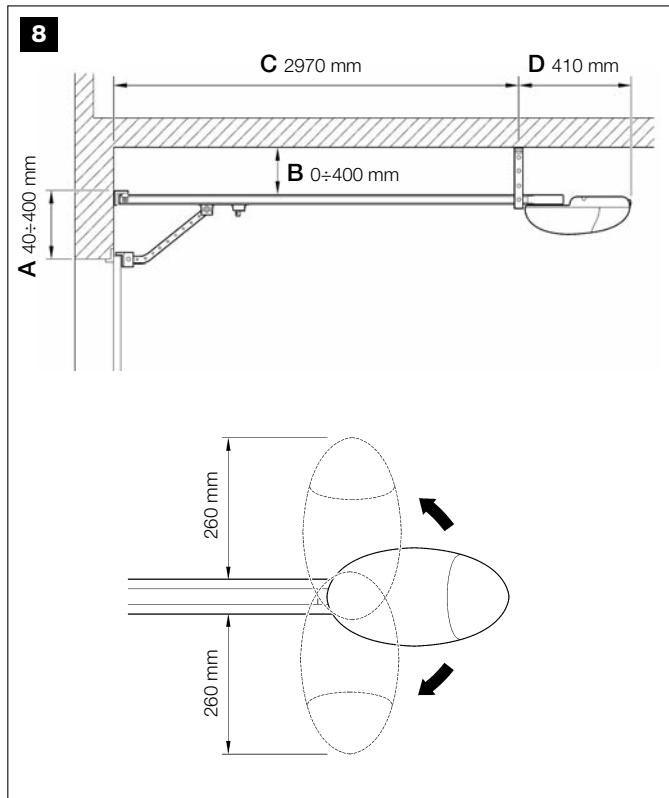

• Pay attention in particular to the methods for securing the head of the guide and the brackets to the ceiling. The head of the guide will have to bear all the strain of opening and closing the door; the ceiling-mounted brackets will have to bear all the weight of GD0. In both cases, the wear and deformations that may occur in time must be taken into consideration.

• The gearmotor should be mounted so that it coincides with the centre of the door, or is slightly off-centre, e.g. in order to mount the OSCILLATING ARM next to the handle (Figure 9).

- Make sure that, in the position corresponding to the door, or slightly to the side, (see positions "A" and "B") the conditions are suitable for mounting the head of the guide; in particular, the material should be sufficiently sturdy and compact.

Make sure that GD0 can be mounted on the ceiling along position "C" using the mounting brackets.

If the door to be automated is an overhead type with springs or counterweights, it will be necessary to install an OSCILLATING ARM, which must be mounted next to the handle (Figure 9).

- Make sure that distance [E] in Figure 10, i.e. the minimum distance between the upper side of the guide and the maximum point reached by the upper edge of the door, is no shorter than 65 mm and no longer than 300 mm, otherwise GD0 cannot be installed.

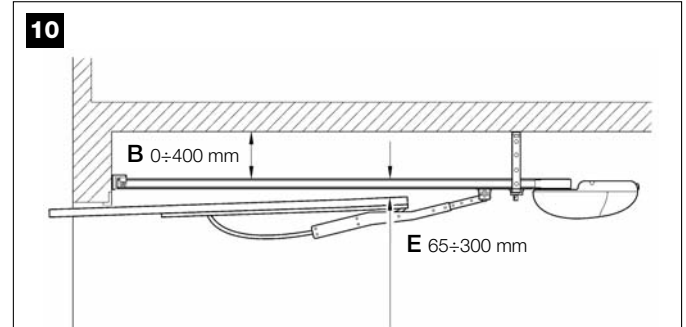

If the door closes a room that has no other means of access, we recommend installation of the EXTERNAL RELEASE KIT, otherwise a simple power failure will prevent access to the room (figure 11 and 11a).

Note: the oscillating arm and external release kit are supplied with the related assembly instructions.

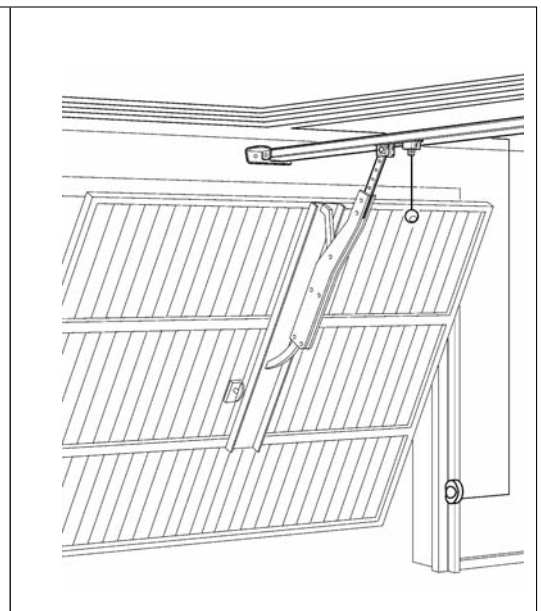
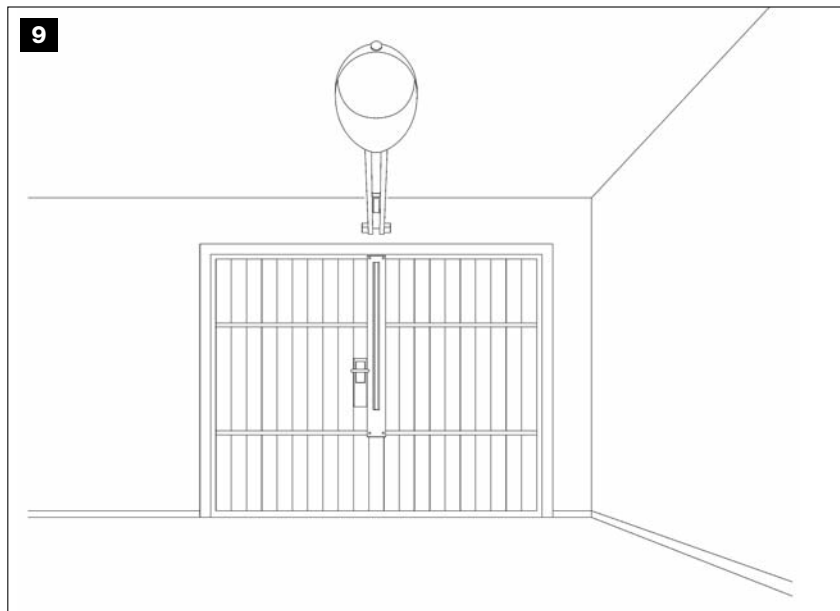
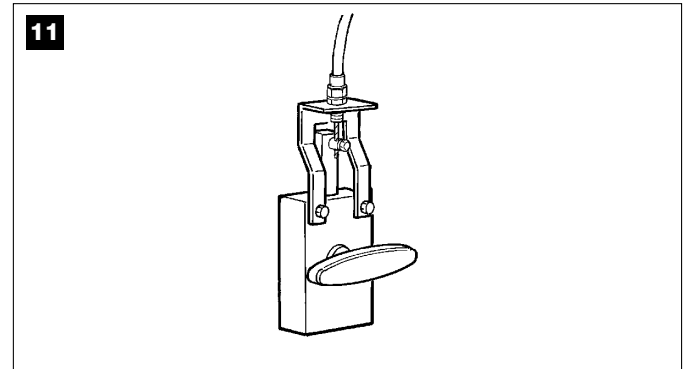

11a**EXTERNAL MANUAL RELEASE****1) Fit the lever**

[A] Lever

[B] Black screw

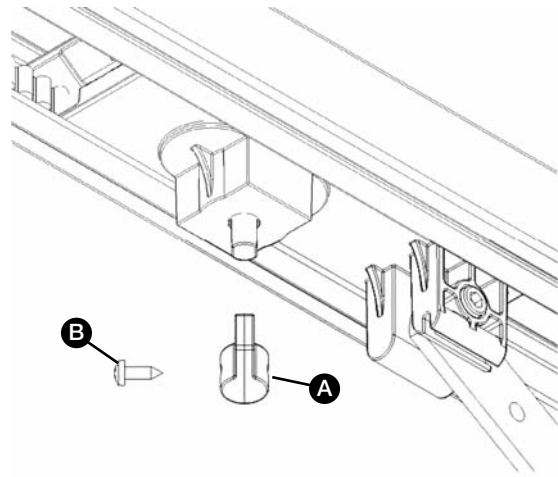
**2) Fit the steel cable**

[C] Sheath

[D] Steel cable

[E] Clamp

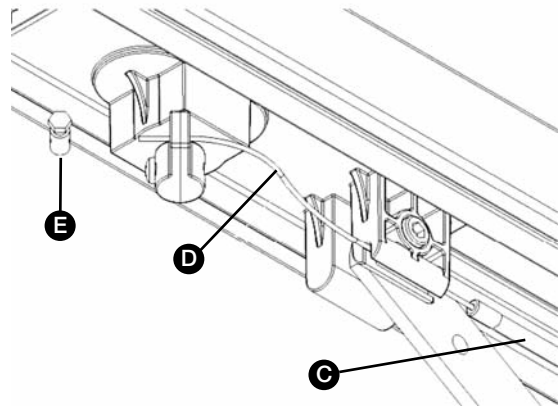
**3.1.1 – Operating limits**

Chapter 6 “Technical Characteristics” provides the fundamental data needed to determine whether all the GDO components are suitable for the intended application.

In general GDO is suitable for the automation of sectional and overhead doors for residential applications having the following maximum dimensions:

Sectional doors: 240 cm max. height - 370cm (8.8m²) max. width - maximum torque 55 kg.

Overhead garage doors non-protruding: 220 cm max. height - 350 cm (7.7m²) max. width - maximum torque 55 kg.

Overhead garage doors protruding: 280 cm max. height - 350 cm (9.8m²) max. width - maximum torque 55 kg.

The shape of the door and the climatic conditions (e.g. presence of strong wind) may reduce this maximum limit. In this case it is necessary to measure the torque needed to move the door under the worst conditions, and to compare it to the data provided in the technical characteristics chart for the GDO gearmotor.

3.1.2 – Tools and Materials

⚠ Make sure you have all the tools and materials needed to install the system; make sure that they are in good condition and serviceable according to current safety standards. See examples in figure 12.

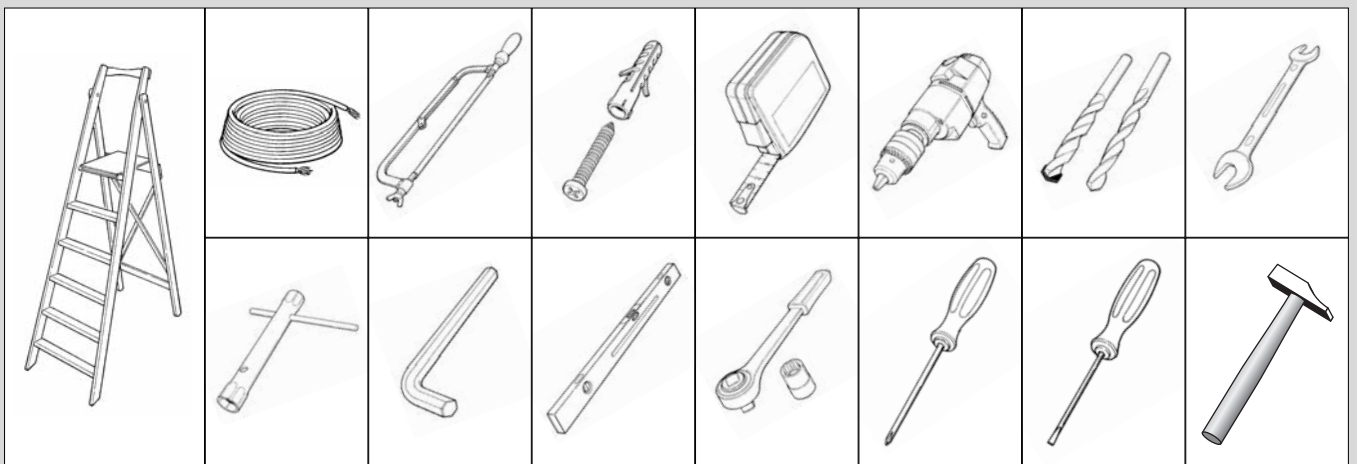
12

3.1.3 – List of cables

The cables required for the installation of GD0 may vary depending on the type and quantity of devices to be installed; figure 13 shows the cables needed for a typical installation; no cable is supplied with GD0.

13

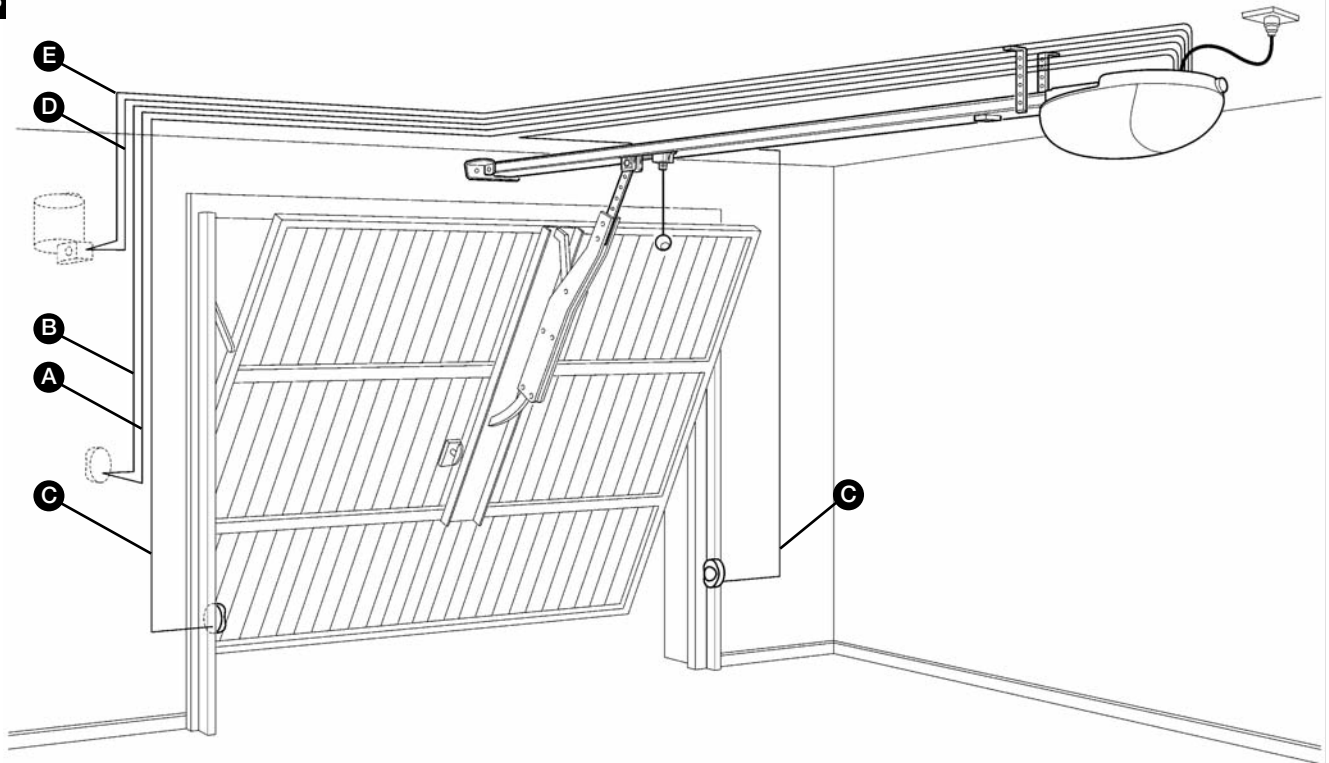

Table 5: List of cables

Connection	Cable type	Maximum length allowed
[A] STOP input	2 x 0,25 mm ² cable	20 m (note 1)
[B] OPEN input	2 x 0,25 mm ² cable	20 m (note 1)
[C] FOTO input	TX 2 x 0,25 mm ² cable RX 3x 0,25 mm ² cable	20 m (note 1)
[D] FLASH light output	2 x 0,25 mm ² cable	20 m
[E] Radio aerial	RG58 type shielded cable	20 m (recommended less than 5m)

Note 1 – For the PHOTO, STOP and OPEN cables, there are no special contraindications to the use of a single cable that groups together multiple connections; for example, the STOP and OPEN inputs can be connected to the KS1 selector switch using a single 4x0.25mm² cable.

WARNING: the cables used must be suitable for the type of installation; for example, an H03VV-F type cable is recommended for indoor applications.

3.2 – PREPARING THE ELECTRICAL SYSTEM

With the exception of the plug and the power cable, the rest of the system uses extra-low voltage (approx. 24V); the wiring can therefore be done by personnel that is not properly qualified, provided that all the instructions in this manual are carefully observed.

After selecting the position of the various devices (refer to figure 13) you can start preparing the conduits for the electrical cables connecting the devices to the control unit.

The shock-resistant conduits are designed to protect the electrical cables and prevent accidental breakage.

Install any fixed control close to the door but away from moving parts and at a height of 1.5m.

3.2.1 – Connection to the Electrical Mains

Although the connection of GD0 to the electrical mains is beyond the scope of this manual, we wish to remind you that:

- The power supply line must be laid and connected by a qualified professional electrician.
- Have a suitably protected 16A “schuko” outlet installed, where you can plug in GD0.
- Make sure that the power supply cable does not hang over moving parts or hazardous areas.
- The electric line must be grounded and protected against short circuits; a bipolar disconnection device must also be present with contact separation of at least 3mm, which allows the power supply to be disconnected during the installation and maintenance of the GD0.

3.3 – INSTALLATION OF THE VARIOUS DEVICES

The GD0 installation is made up of three parts:

- Guide assembly (see paragraph 3.3.1).
- Fixing of the gearmotor to the guide (see paragraph 3.3.2).
- Fixing of the gearmotor to the ceiling (see paragraph 3.3.3).

3.3.1 – Guide assembly

The guide supplied with the GD0 must be assembled as follows:

1. Referring to figure 14, remove the belt tensioner device (14a); insert one end of the belt into the pulley (14b); reintroduce the belt tensioner device into the guide (14c).

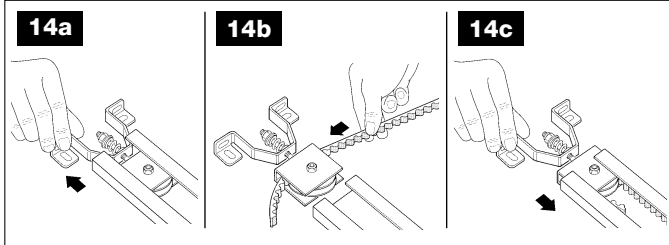

2. Pass the same end of the belt through the head (B), as in figure 15.
Note – Make sure that the belt is correctly positioned: it must be with the teeth facing inwards, straight and without twists.

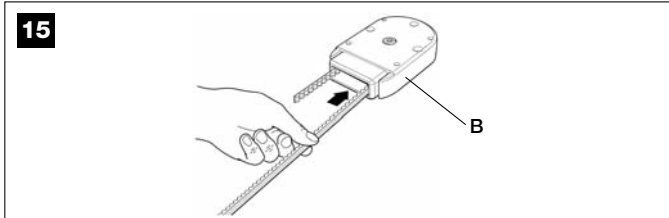

3. Turn the lower section of the carriage so that the grooves correspond with the two ends of the belt, as in figure 16.

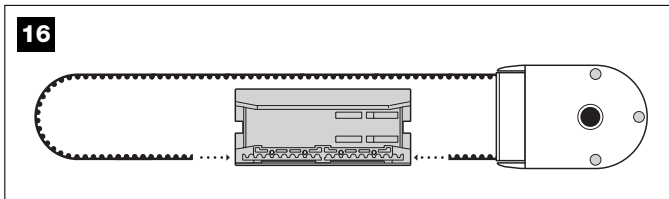

4. Position both ends of the belt into all of the shaped slots of the lower carriage (C). Secure the ends of the belt with the 2 screws (V4.2x9.5) and 2 washers (R05), as in figure 17.

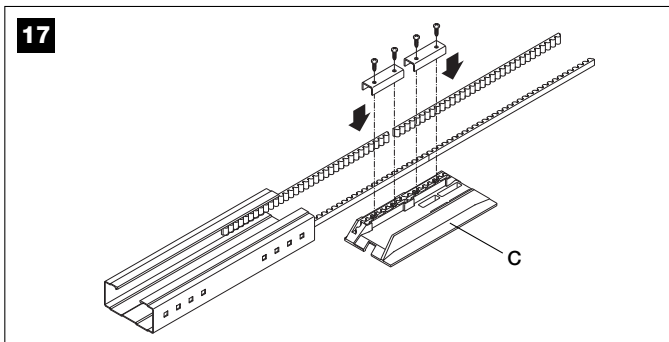

5. Fix the belt guide (D) to the upper carriage (E) with the V6x18 screw and related M6 nut, as in figure 18.

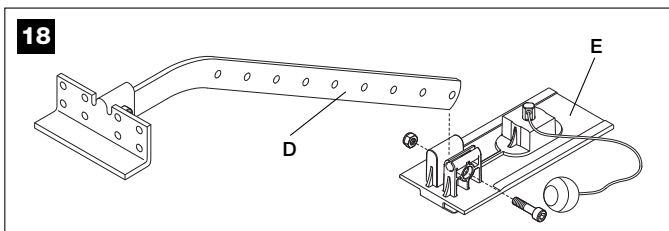

6. Insert the upper carriage (E) into the lower carriage (C) and place the entire carriage assembly inside the guide, as in figure 19.

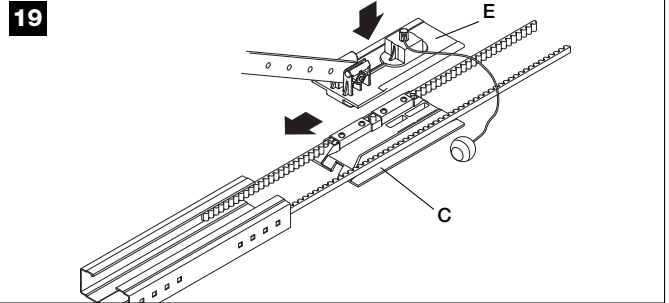

7. With the aid of a hammer, assemble the three pieces of the guide engaging them into the connection brackets (F) with force, as in figures 20 and 21.

Important – the guides must slide into the brackets until they click into position.

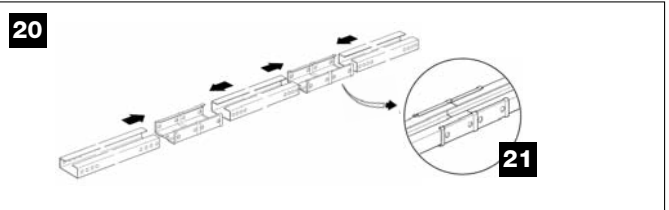

8. Carefully position the belt into the guide, making sure that it is not twisted.

9. Fix the head (B) into the free end of the guide with force, as in figure 22.

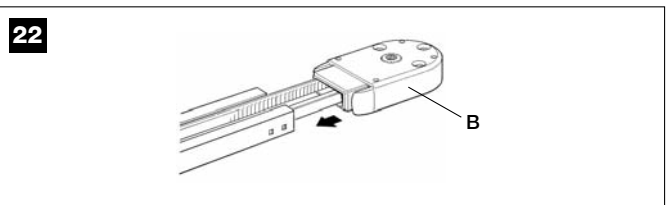

10. Finally, tension the belt with the adjustment screw (H) of the belt tensioner device, as in figure 23.

Warning - the gear-motor could break if the belt is too taut and if it is too slack, it could cause unpleasant noise.

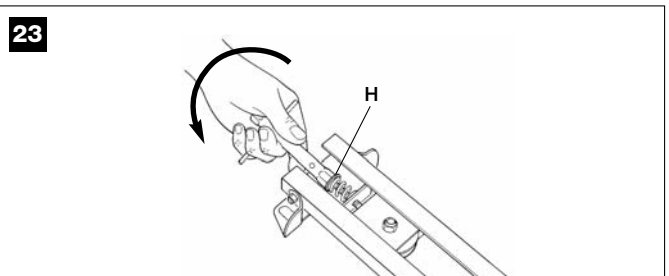

3.3.2 – Fixing of the gearmotor to the guide

- 1 Couple the GD0K gearmotor's shaft extension with the head of the guide [B], then secure them using the four M6.3x38 screws [I],

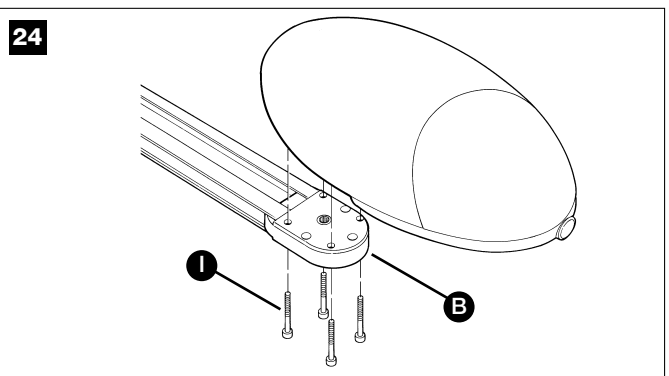

The gearmotor can be rotated in three different positions

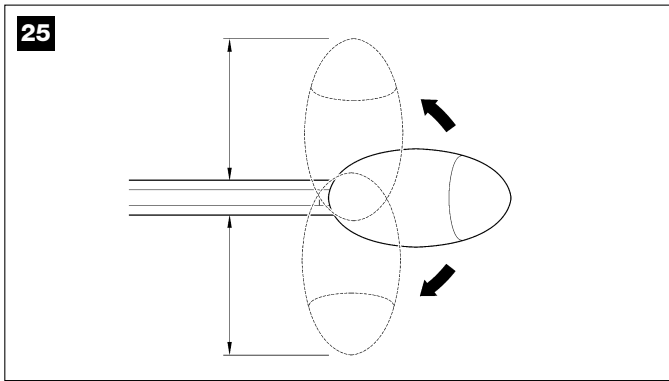

3.3.3 - Fixing of the gearmotor to the ceiling

1 Observing the A, B and C positions shown in Figure 8, mark the 2 fastening points for the guide's front bracket in the centre of the garage door (or slightly off-centre - Figure 11). Depending on the type of material, the front bracket can be fastened using rivets, anchors or screws (Figure 26). If positions A, B, and C (figure 8) allow it, the bracket can be fastened directly to the ceiling.

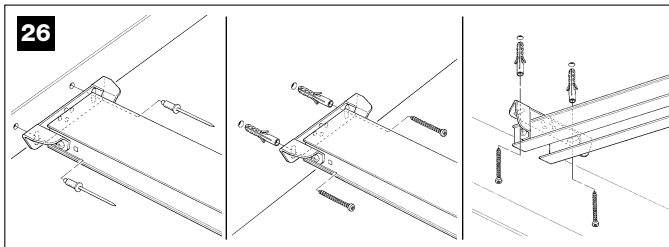

2 After drilling the holes, leave the head of the gearmotor on the ground, lift the guide from the front and secure it with two screws, anchors or rivets depending on the type of surface.

3 Secure the mounting brackets [L], using the screws [M] and nuts [N], and choosing the hole that is closest to the established position B (see Figure 8)

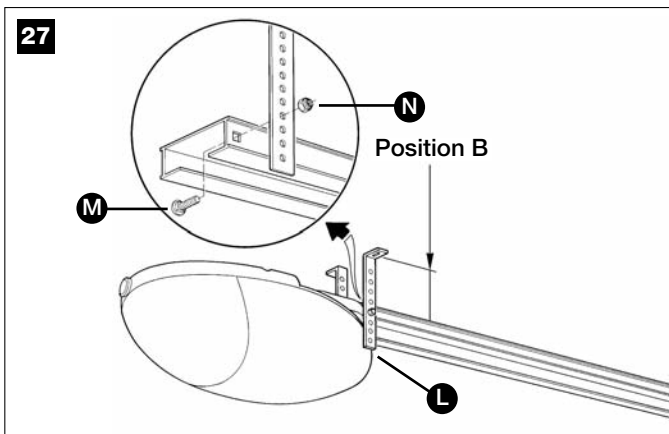

4 Using a ladder, lift the gearmotor and position the brackets against the ceiling. Mark the drilling points, then put the gearmotor back on the ground.

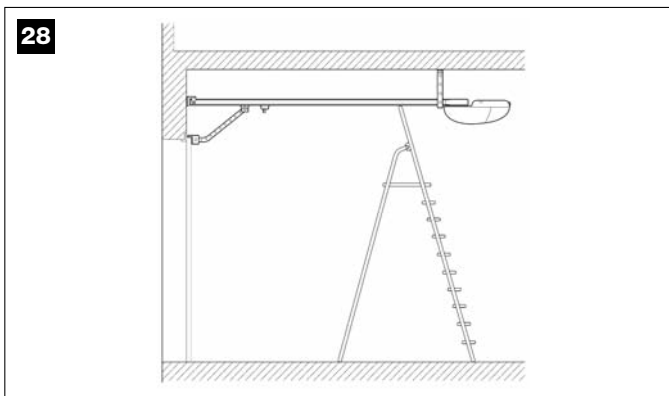

5 Using a ladder, drill the marked positions and place the brackets over the holes which have just been drilled and, using suitable screws and plugs, secure the brackets.

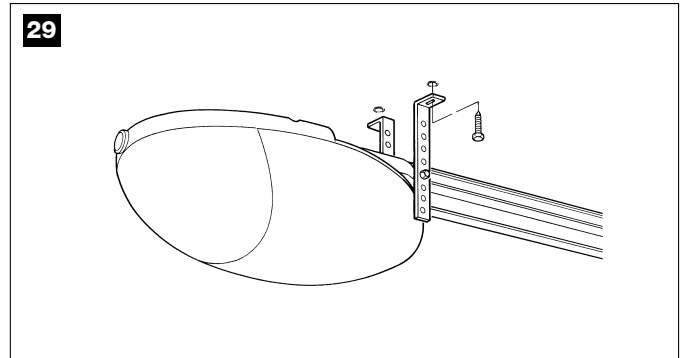

6 Make sure that the guide is perfectly horizontal, then cut the excess of the brackets using a hacksaw.

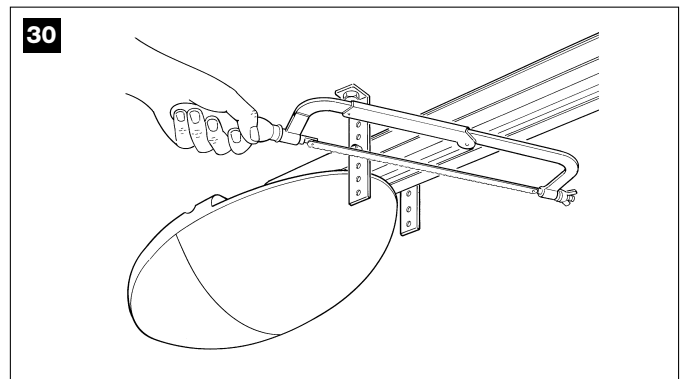

7 With the door closed, pull the cord and release the carriage [E] from the guide.

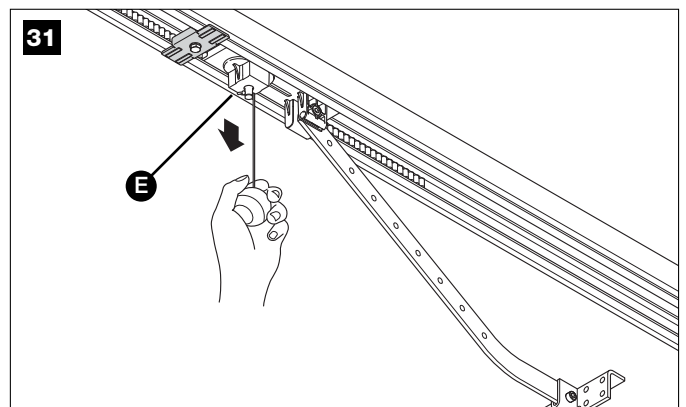

8 Slide the carriage until the door mounted bracket [D] shown in Figure 32 is positioned on the upper edge of the door, exactly perpendicular to the guide [G].

Next, secure the door mounted bracket [D] with screws or rivets. Use screws or rivets that are suitable for the door material, making sure that they are capable of bearing all the strain resulting from opening and closing the door.

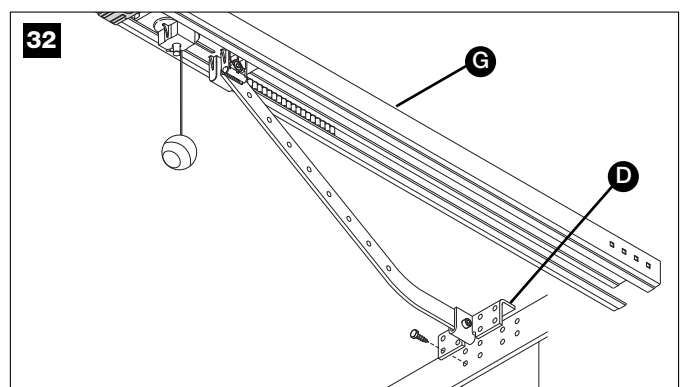

9 Loosen the screws in the two mechanical stops, then place the front mechanical stop [O] before the carriage (Figure 33). Push the carriage hard in the closing direction and, in the reached position, tighten the screw firmly [P].

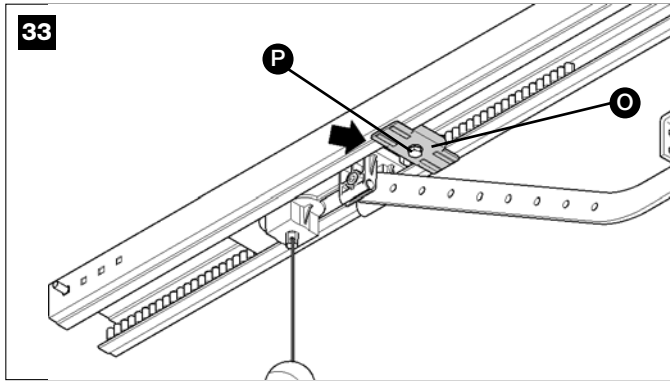

10 Open the door manually to the desired open position, then place the rear mechanical stop [Q] near the carriage (Figure 34), and secure it tightening the screw firmly [R].

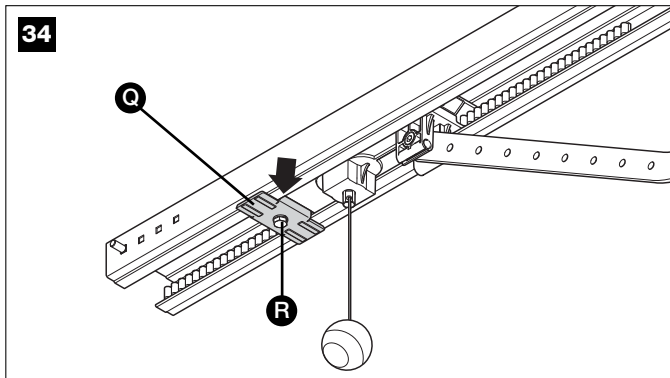

11 Make sure that the release cord can be activated at a height less than 1.8m.

3.3.4 – PHO Photocells (optional)

1 Select the position of the two elements that make up the photocell (TX and RX) observing the following directions:

Position them at a height of 20-25 cm from the ground, on both sides of the area to be protected and as close as possible to the edge of the door. With sectional doors, the photocells can be mounted outside, whereas with overhead doors they can only be mounted inside (outside they would obstruct the movement of the door)

- Point transmitter TX towards receiver RX, with a maximum tolerance of 5°.
- In the selected locations there must be a conduit for threading the cables.

2 Remove the front glass [A] by prising it out with a slotted tip screwdriver applied to the bottom.

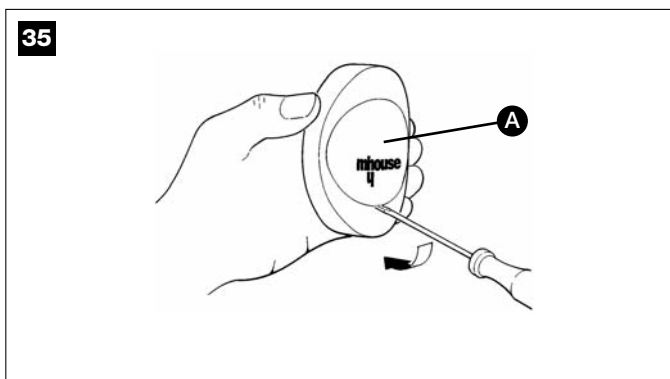

3 Press the lens in order to separate the two shells.

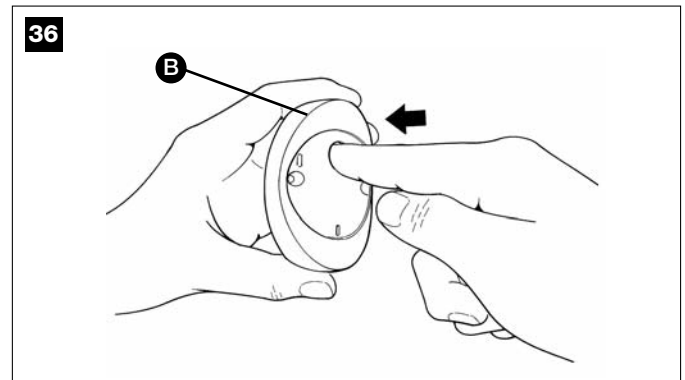

4 Breach two of the four holes [B] at the bottom with a screwdriver.

5 Position the photocell at the point where the conduit arrives; the hole at the bottom [D] should match the point where the cables come out of the wall; mark the drilling points using the bottom as reference.

6 Drill the holes in the wall using a hammer drill with a 5 mm bit and insert the 5 mm screw anchors.

7 Secure the bottom with the screws [C].

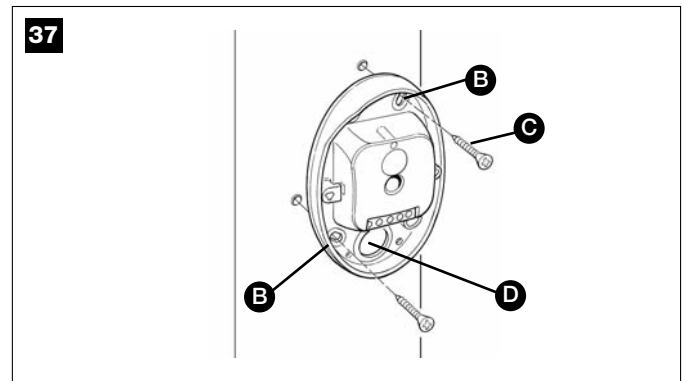

8 Connect the electric cable to the appropriate TX and RX terminals. See paragraph 3.3.7 for electrical connections “Electrical connections to the GDOK control unit” and 5.3.1 “Phototest output”.

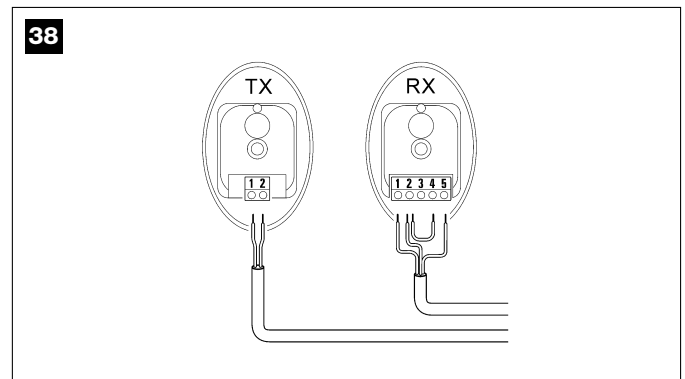

9 Secure the cover shell [E] using the two screws [F] and a Phillips screwdriver. Then insert the glass [G], pressing it gently to close it.

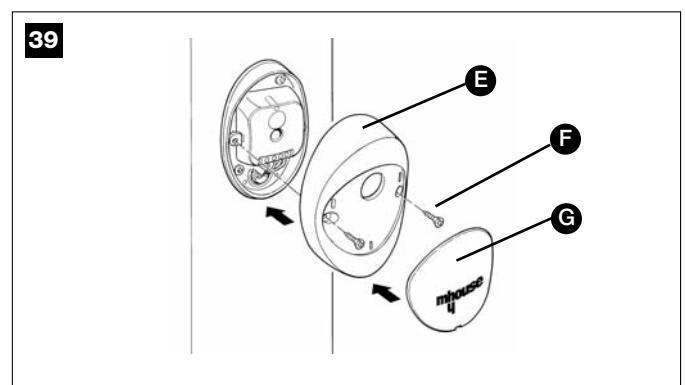

3.3.5 – KS1 key-operated selector switch (optional)

1 Determine the position of the selector switch; it must be installed outdoors, alongside the gate and at a height of approx. 80 cm, so that it can be used by people of different height.

2 Remove the front glass [A] by prising it out with a slotted tip screwdriver applied to the bottom.

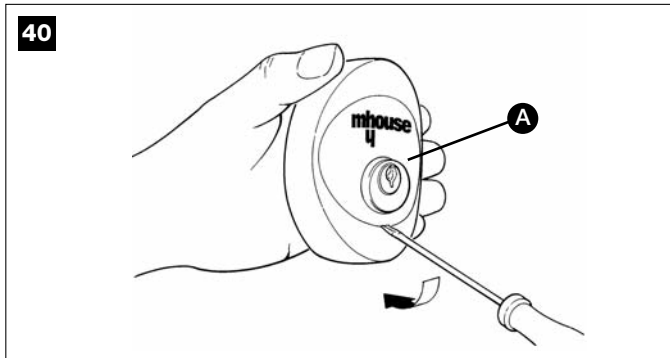

3 To separate the bottom from the shell you need to insert the key and keep it turned, then pull with a finger inserted in the hole for the passage of the cables.

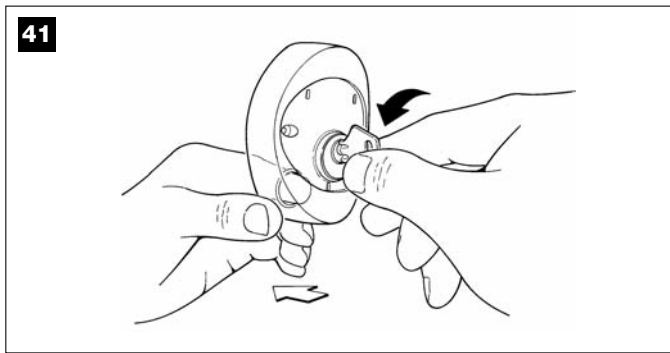

4 Breach the four holes at the bottom with a screwdriver; mark the drilling points using the bottom as reference; make sure that the hole in the bottom matches the outlet for the cables.

5 Drill the holes in the wall using a hammer drill with a 5 mm bit and insert the 5 mm screw anchors.

6 Secure the bottom using the four screws [A].

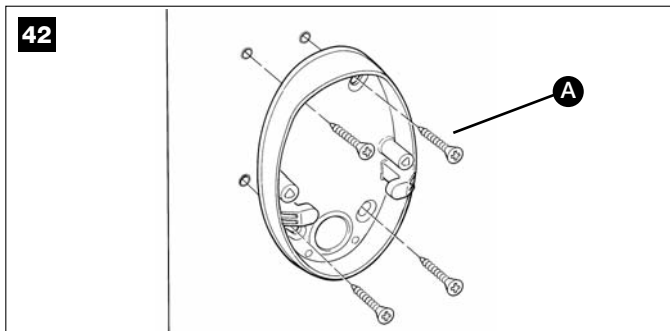

7 Connect the electric cables to the appropriate OPEN and STOP terminals, as shown in figure 43. It is not necessary to observe any polarity. The terminals can be removed in order to facilitate the operations; make the connections and then reinsert them.

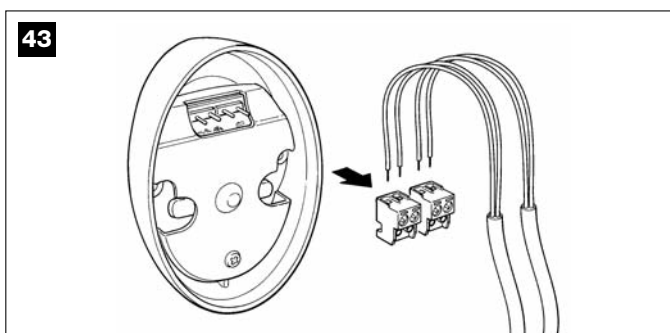

8 To insert the shell on the bottom you need to turn the key. After you have inserted it, turn the key back to the centre position.

9 Secure the body [C] using the two screws [D] and a Phillips screwdriver. Finally insert the glass [E], pressing it gently to close it (Figure 44).

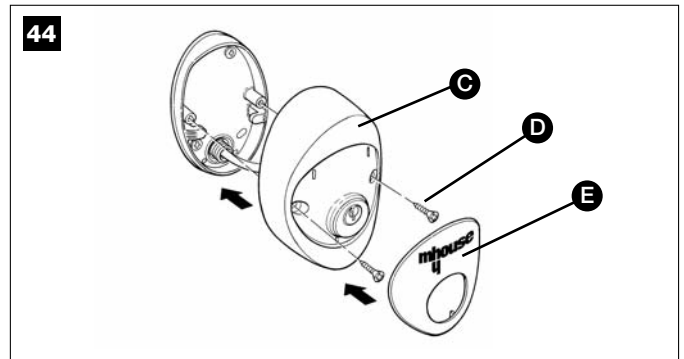

3.3.6 – FL1 flashing light (optional)

1 Determine the position of the flashing light: it should be near the door and easy to see; it can be secured to a horizontal as well as vertical surface.

2 Slide out the diffuser [A] from the bottom by pressing the two buttons [B].

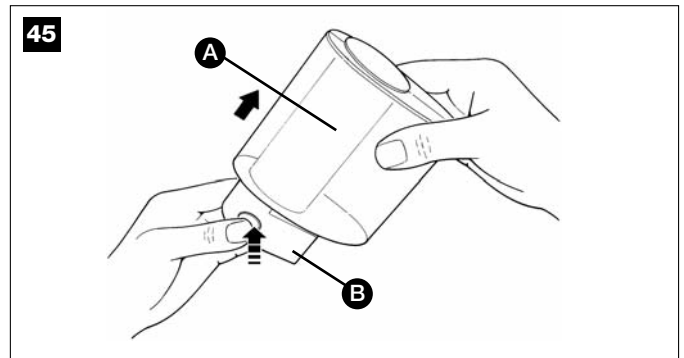

3 Separate the lamp holder with the aerial from the base.

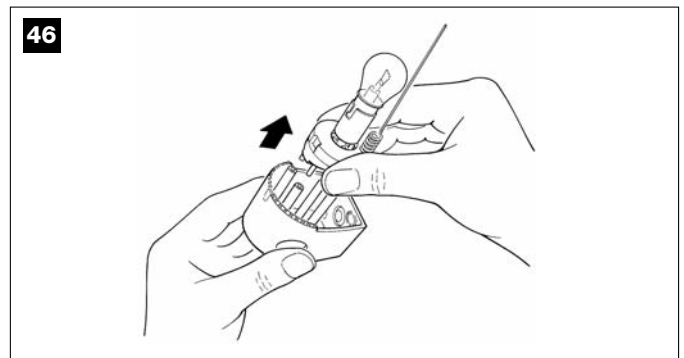

4 Breach the four holes for the screws and the hole for the passage of the cables in the bottom or side, depending on the installation position, using a screwdriver.

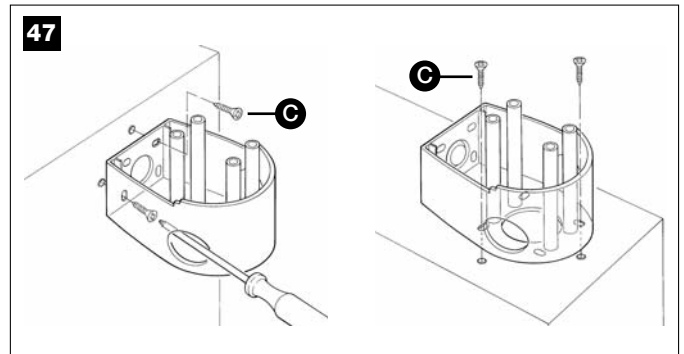

5 Mark the drilling points using the bottom as reference and make sure that the hole in the bottom matches the outlet for the cables.

6 Drill the holes in the wall using a hammer drill with a 6 mm bit and insert the 6 mm screw anchors.

7 Secure the bottom with the screws [C].

8 Connect the electrical cables to the appropriate FLASH and "aerial" terminals as shown in figure 48. You do not need to observe any polarity on the FLASH terminal; however, for the connection of the shielded cable to the aerial, connect the braid as shown in figure 49. The terminals can be removed in order to facilitate the operations; make the connections and then reinsert them (Figure 50).

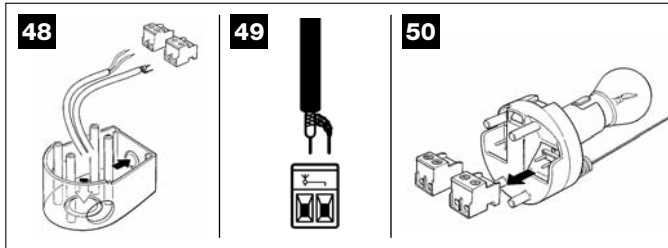

9 Fit the lamp holder on the base and press it down until it snaps into position.

10 Slide in the diffuser, pressing the buttons and fitting it on the bottom. Rotate it in the desired direction then press it down until the two buttons snap into their seat.

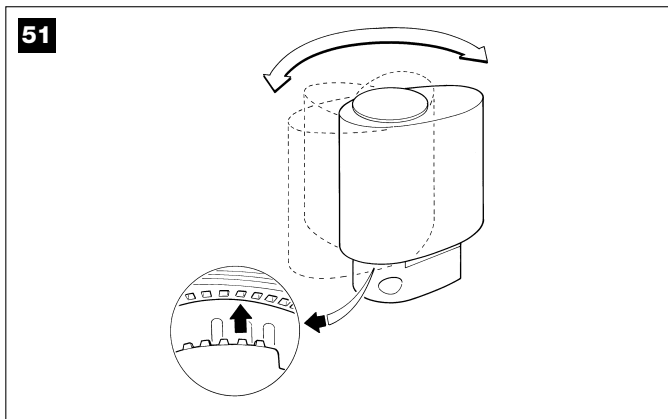

3.3.7 – Electrical connections to the GDOK control unit

1 Unscrewing screw [A] and pushing button [B], open the lid.

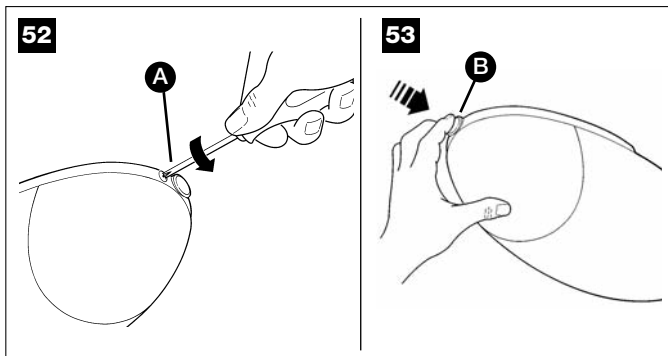

2 Remove the circular part [C] with a screwdriver, as in fig. 54.

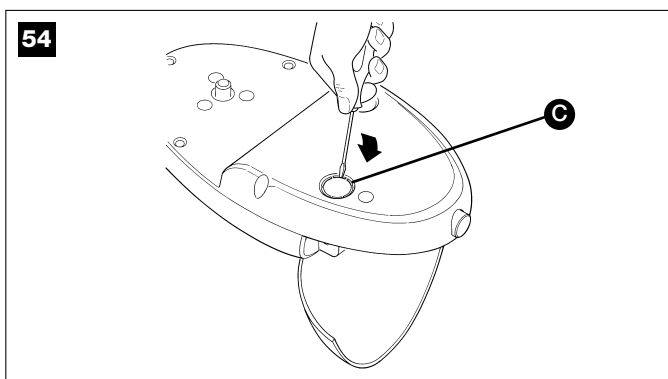

3 Cut the rubber membrane [D] so that the cables can pass and insert it in the hole [C].

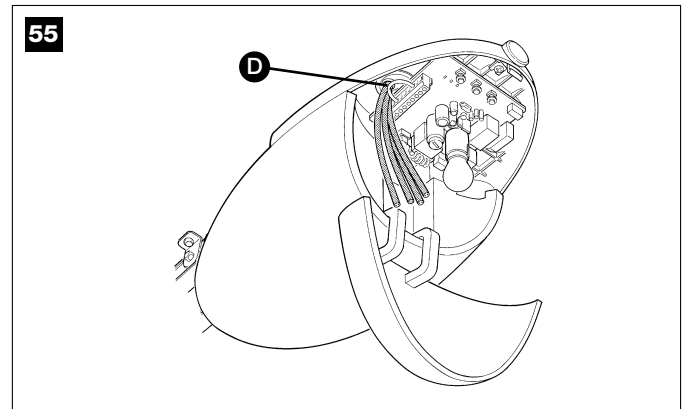

4 Use Fig. 56 and the connection description in Table 6 as reference.

- if using the PH0 photocell, remove the small piece of wire between terminals 3 and 7 and make the connections as in Fig. 56.
- if using the flashing light aerial, remove the piece of wire, which is connected to terminal 2, and connect the RG58 type shielded cable.

5 When the connections have been completed secure the cables using suitable clamps.

6 To close the cover, turn and push until a click is heard. Secure the screw [A].

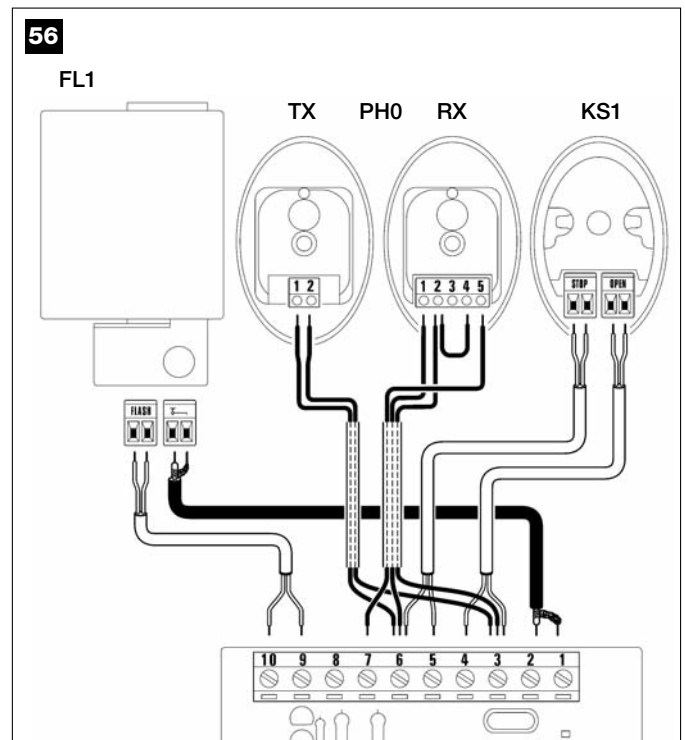

TABLE 6

Terminals	Functions	Description
1-2	Aerial	Radio receiver aerial connection input. The FL1 has a built-in aerial, alternatively an external aerial can be used or the small piece of wire that is already connected to the terminal can be left, which acts as an aerial.
3-4	OPEN	Input for manoeuvre control devices; "Normally Open" type contacts can be connected.
5-6	STOP	Input for the devices which block or eventually stop the manoeuvre in progress. Contacts like "Normally Closed", "Normally Open" or constant resistance devices can be connected using special procedures on the input. Additional information on STOP can be found in paragraph "5.3.2 STOP input".
3-7	FOTO	Input for safety devices such as PH0 photocells. Cut-in during closure, inverting the manoeuvre. "Normally Closed" contacts can be connected. The PHOTO input is factory set short-circuited by means of a jumper between inputs 3 and 7 of the terminal. Additional information on PHOTO can be found in paragraph "3.3.4 PH0 Photocells (optional)".
6-8	Phototest	All safety devices are controlled each time a manoeuvre is performed and the manoeuvre is only performed if the test has a positive outcome. This is possible by means of a special connection; the "TX" photocell transmitters are powered separately in respect to the "RX" receivers. Additional information on connections can be found in paragraph "5.3.1 Phototest output".
9-10	Flashing light	An FL1 flashing light with a 12V 21W car bulb can be connected to this output. During the manoeuvre the unit flashes at intervals of 0.5 s.

3.4 – POWER SUPPLY CONNECTION

The connection of the GD0 control unit to the mains must be made by a qualified electrician.

To carry out tests, insert the plug for GD0K in a power outlet; if necessary, use an extension cord.

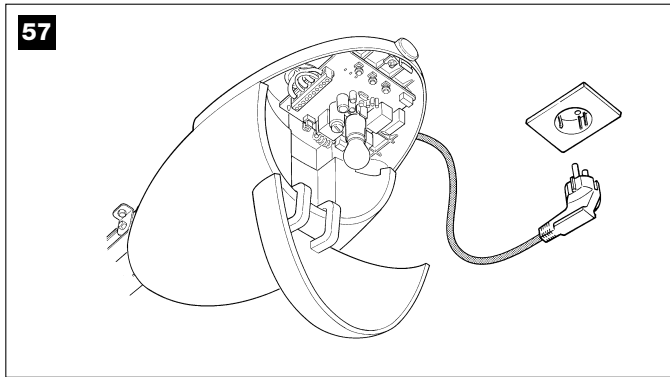

3.5 – INITIAL CHECKS

As soon as the control unit is energized, you should check the following:

1 Make sure that the LED [A] flashes regularly, with about one flash per second.

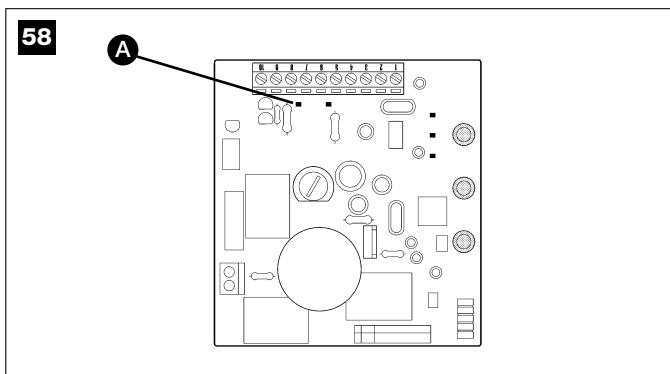

2 If the system is equipped with the PH0 photocells, make sure that the SAFE LED [B] shown in figure 59 flashes (on both TX and RX). The type of flashing is irrelevant, it depends on other factors; what matters is that it is not always off or always on.

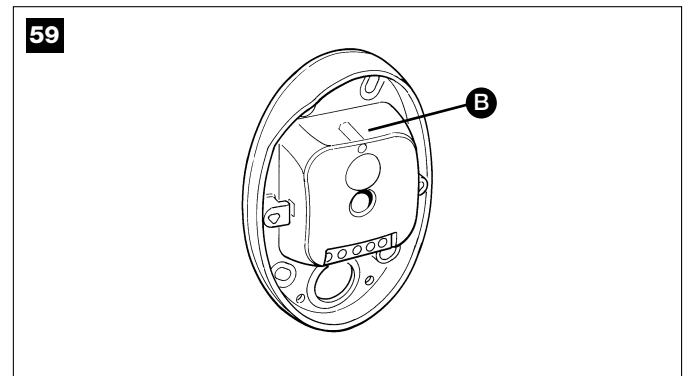

3 If the system is equipped with the KS1 key-operated selector switch, make sure that the night light [C] is on.

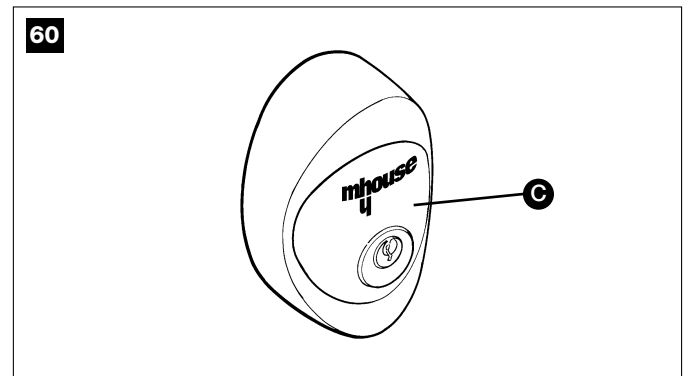

4 If the above conditions are not satisfied, you should immediately switch off the power supply to the control unit and check the cable connections more carefully. For more useful information see also chapters 5.5 "Troubleshooting" and 5.6 "Diagnostics and Signals".

3.5.1 – Recognition of the door's open and closed positions

The opening and closing positions of the door must be recognised by the control unit. In this phase, the door stroke from the mechanical closing stop to the mechanical opening stop is detected. In addition to the positions, the STOP input configuration and the presence or non-presence of the PHOTO input "Phototest" mode connection are also detected and memorised in this phase.

1 Make sure that the carriage is attached.

2 Press key P3 [A] on the control unit and hold it down for at least three seconds, then release the key (Figure 61).

- Wait until the control unit has completed the recognition stage: closing, opening and re-closing of the door.
- If any device is triggered during the recognition stage, or the P3 key is pressed, the recognition stage will be immediately interrupted. In this case it must be repeated from the beginning.
- During the recognition stage the courtesy light will flash just like the flashing light.

3 An error has occurred if the LEDs P2 and P3 [B] are flashing at the end of the recognition stage. See paragraph 5.5 "Troubleshooting".

4 Press button 1 of the "TX4" transmitter to perform a complete opening manoeuvre. Then push it again to perform a complete closing manoeuvre. The control unit memorises the necessary force throughout the travel during these two manoeuvres.

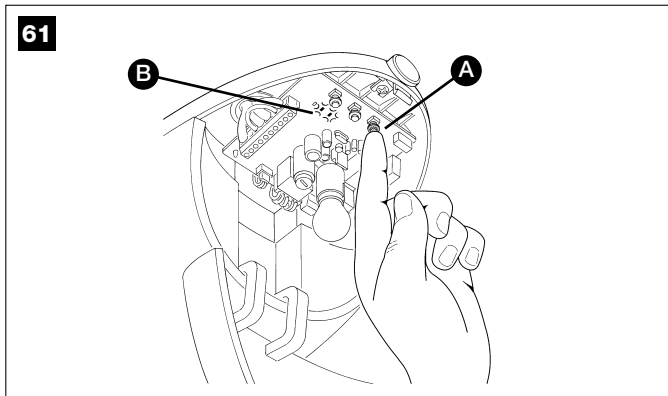

It is important that these two first manoeuvres are not interrupted by any commands. If the manoeuvres are not completed, repeat the recognition procedure starting from step 1.

The position recognition stage can be repeated at any time in the future (for instance, if one of the mechanical stops is moved); just repeat starting from step 1.

WARNING: if the belt is not tightened properly, during the search for the positions it may slip on the pinion. If this happens, stop the leaning procedure by pressing key P3 and stretch the belt by tightening the nut [D]. Then repeat the recognition procedure starting from step 1.

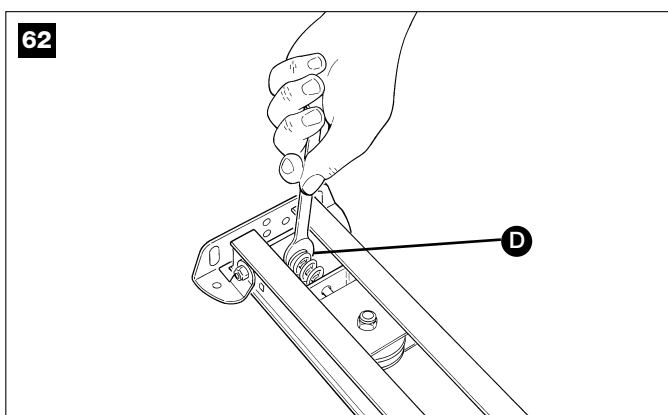

3.5.2 – Testing the radio transmitter

To test the transmitter just press one of its 4 keys, make sure that the red LED flashes and that the automation carries out the related command. The command associated to each button depends on how it has been memorized (see paragraph 5.4 "Memorization of Radio Transmitters"). The transmitter supplied has already been memorized and when you press the buttons the following commands are transmitted:

Button T1	"OPEN" command
Button T2	"Open partially" command
Button T3	"Open only" command
Button T4	"Close only" command

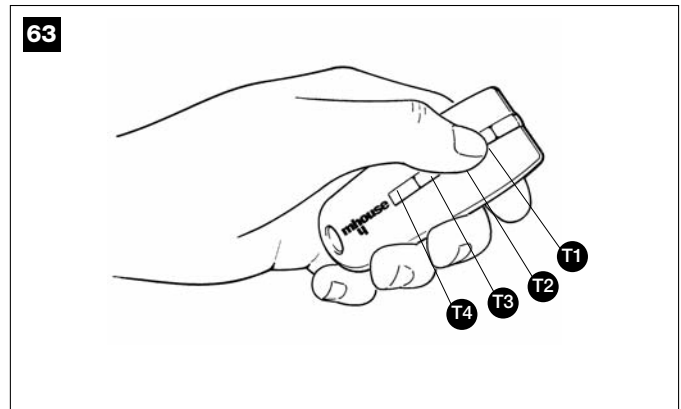

3.6 – REGULATIONS

3.6.1 – Selecting door speed

The door can be opened and closed at two speeds: "slow" or "fast".

To switch from one speed to the other press the P2 button [B] momentarily; the corresponding P2 LED [A] will light up or go off; if the LED is off the speed is "slow", if the LED is on the speed is "fast".

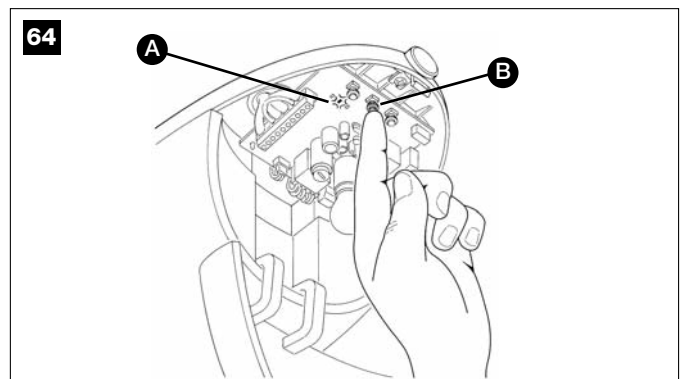

3.6.2 – Selecting the type of operating cycle

The opening and closing of the door can take place according to different operating cycles:

- single cycle (semiautomatic): the door opens with a command and stays open until the next command is given, causing it to close.
- complete cycle (automatic closing): the door opens with a command and then closes automatically after a short time (for the time, see paragraph 5.1.1 "Adjusting the parameters with the radio transmitter").

To switch from one operating cycle to the other, press the P3 button [B] momentarily; the corresponding LED P3 [A] will light up or go off; if the LED is off the cycle is "single", if the LED is on the cycle is "complete".

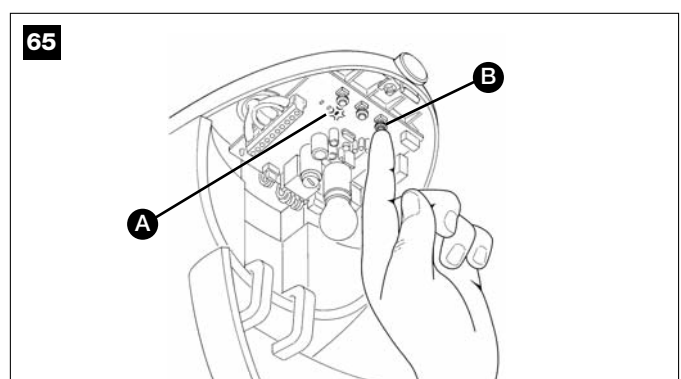

3.7 – TESTING AND COMMISSIONING

These are the most important operations, designed to guarantee the maximum safety and reliability of the automation system.

The testing procedure can also be used as a periodic check of the devices that make up the automation.

The testing and commissioning operations must be performed by qualified and experienced personnel who must establish what tests should be conducted based on the risks involved, and verify the compliance of the system with applicable regulations, legislation and standards, in particular with all the provisions of EN standard 12445 which establishes the test methods for sectional and overhead door automation systems.

3.7.1 – Testing

1 Make sure that the provisions contained in chapter 1 “WARNINGS” have been carefully observed.

2 Using the selector switch (if provided) or the radio transmitter, test the opening and closing of the door and make sure that the door moves in the intended direction.

The test should be carried out a number of times to make sure that the door moves smoothly, that there are no points of excessive friction and that there are no defects in the assembly or adjustments.

3 Check the proper operation of all the safety devices, one by one (photo-cells, sensitive edges, etc.). In particular, each time a device is activated the “ECSBus” LED on the control unit flashes for a longer time, confirming that the control unit recognizes the event.

4 To check the photocells (if provided) pass a 5 cm diameter, 30 cm long cylinder on the optical axis, first near TX, then near RX and finally at the mid-point between them and make sure that in all these cases the device is triggered, switching from the active to the alarm status and vice-versa; finally, that it causes the intended action in the control unit, for example that it causes the reversal of the movement during the closing manoeuvre

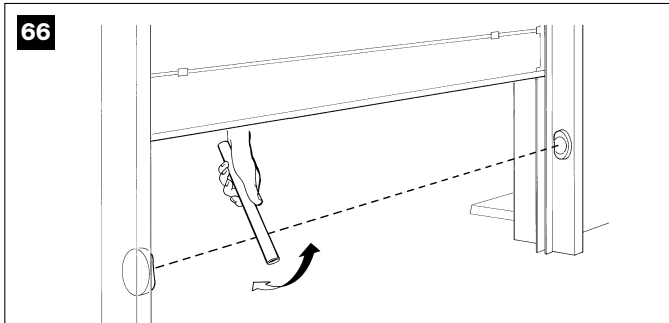

5 Measure the impact force according to EN standard 12445. If “motor force” control is used to assist the system for the reduction of the impact force, try to find the adjustment that gives the best results.

6 Ensure that the entire mechanism is correctly adjusted and that the automation system inverts the manoeuvre when the door collides with a 50 mm high object on the floor.

7 Ensure that the automation prevents or blocks the opening manoeuvre when the door is loaded with a mass of 20 Kg, fixed in the middle of the doors lower edge.

3.7.2 – Commissioning

The commissioning operations can be performed only after all the tests have been successfully carried out. Partial commissioning or implementation of “temporary” conditions are not permitted.

1 Prepare the technical documentation for the automation, which must include at least: assembly drawing (e.g. figure 1), wiring diagram (e.g. figure 56), analysis of hazards and solutions adopted, manufacturer’s declaration of conformity of all the devices installed. For GDO use Annexe 1 “EC Declaration of Conformity of the GDO components”

2 Post a label on the door providing at least the following data: type of automation, name and address of manufacturer (person responsible for the “commissioning”), serial number, year of manufacture and “CE” marking.

3 Fill out the declaration of conformity and deliver it to the owner of the automation system; for this purpose you can use Annexe 2 “EC Declaration of Conformity”.

4 Prepare the operating guide and deliver it to the owner of the automation system; Annexe 3 “OPERATING GUIDE” can be used as an example.

5 Prepare the maintenance schedule and deliver it to the owner of the automation system; it must provide directions regarding the maintenance of all the automation devices.

6 Post a permanent label or sign detailing the operations for the release and manual manoeuvre (use the figures in Annex 3 “Operating guide”).

7 Before commissioning the automation system inform the owner regarding dangers and hazards that are still existing.

8 Post a permanent label or sign with this image on the door (minimum height 60 mm) with inscription WARNING – RISK OF CRUSHING.

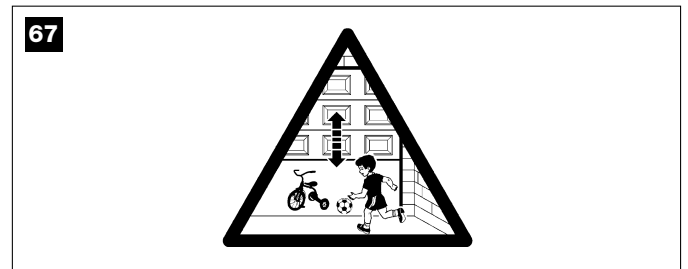

MAINTENANCE

STEP 4

The maintenance operations must be performed in strict compliance with the safety directions provided in this manual and according to the applicable legislation and standards.

The devices used for the GDO automation system do not require any special maintenance. However, periodically make sure (at least once every six

months) that all the devices are perfectly efficient.

To this end, carry out all the tests and checks described in paragraph 3.7.1 “Testing” and the operations described in paragraph 7.3.3 “Maintenance Operations to Be Performed by the User”.

If other devices are present, follow the directions provided in the corresponding maintenance schedule.

PRODUCT DISPOSAL

This product is an integral part of the automation system it controls and must be disposed of along with it.

As in the case of installation, likewise at the end of product lifetime the disassembly and scrapping operations must be performed by qualified personnel.

This product is made of various types of material, some of which can be recycled while others must be scrapped. Seek information on the recycling and disposal methods envisaged by the local regulations in your area for this product category.

Important! – Some parts of the product may contain polluting or hazardous substances which, if released to the environment, may cause serious damage to the environment or to human health.

As indicated by the symbol alongside, disposal of this product with domestic

waste is strictly prohibited. Separate the waste into categories for disposal, according to the methods established by current legislation in your area, or return the product to the retailer when purchasing a new version.

Important! – Local legislation may impose heavy fines in the event of illegal disposal of this product.

Disposal of buffer battery (if present)

Important! – Even if discharged, the batteries may contain pollutant substances and therefore must NEVER be disposed of in normal waste collection points.

Dispose of according to separate waste collection methods as envisaged by current local standards.



ADDITIONAL INFORMATION

STEP 5

The following chapters describe different ways of customizing GD0 to make it suitable for specific application requirements.

5.1 – ADVANCED ADJUSTMENTS

5.1.1 – Adjusting the Parameters with the Radio Transmitter

The radio transmitter can be used to adjust certain control unit operation parameters: there are four parameters and each of them can have four different values:

- 1) Pause time: time during which the door remains open (in the automatic closing mode).
- 2) "OPEN" function: sequence of movements associated to each "OPEN" command.
- 3) Motor force: maximum force beyond which the control unit recognizes an obstacle and reverses the movement.

TABLE 7

Parameter	N°	Setting	Action: operation to be performed at point 3 in the adjustment phase
Pause time	1°	15s	Press button T1 once
	2°	30s (*)	Press button T1 twice
	3°	60s	Press button T1 three times
"OPEN" function	1°	"Open"- "Stop"- "Close"- "Stop"	Press button T2 once
	2°	"Open"- "Stop"- "Close"- "Open" (*)	Press button T2 twice
	3°	"Open"- "Open"- "Open" (opening only)	Press button T2 three times
Motor force	1°	Low	Press button T3 once
	2°	Medium	Press button T3 twice
	3°	High (*)	Press button T3 three times

(*) Original factory setting

The parameter adjustment operation can be performed using a radio transmitter, provided it is memorized in mode 1 like the one supplied. If no transmitter memorized in Mode 1 is available, you can memorize one just for this phase and delete it immediately afterwards (see paragraph 5.4.1 "Mode 1 memorization" and paragraph 5.4.4 "Deleting a radio transmitter").

WARNING: when using the transmitter to make adjustments you need to give the control unit time to recognize the radio command; this means that the buttons must be pressed and released slowly, held down for at least one second, then released for one second and so on.

1 Press buttons T1 and T2 on the radio transmitter simultaneously for at least 5s.

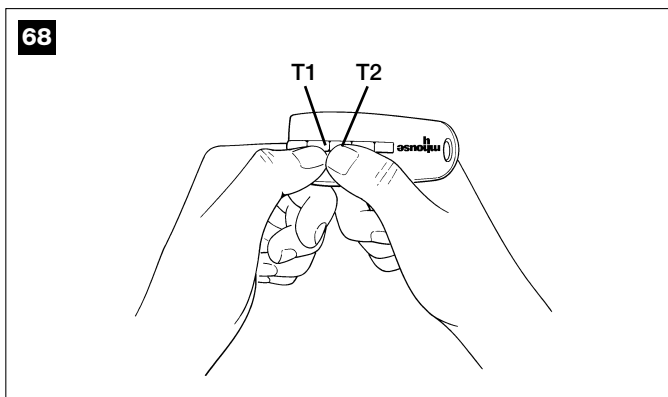

2 Release the two buttons.

3 Within 3 seconds, perform the action described in Table 7 based on the parameter to be modified.

Example: to set the pause time at 60 s.

- 1st Press buttons T1 and T2 and hold them down for at least 5s
- 2nd Release T1 and T2
- 3th Press button T1 three times

All the parameters can be adjusted as required without any contraindication; only the adjustment of the "motor force" requires special care:

- Do not use high force values to compensate for points of abnormal friction on the door. Excessive force can compromise the operation of the safety system or damage the door.

tion on the door. Excessive force can compromise the operation of the safety system or damage the door.

- If the "motor force" control is used to assist the impact force reduction system, measure the force again after each adjustment in compliance with EN standard 12445.
- The weather conditions may affect the movement of the door, therefore periodic re-adjustments may be necessary.

5.1.2 – Checking the Adjustments with the Radio Transmitter

With a radio transmitter memorized in Mode 1 you can check the values set for each parameter at any time by following the sequence described below:

1 Press buttons T1 and T2 on the radio transmitter simultaneously for at least 5s.

2 Release the two buttons.

3 Within 3 seconds, perform the action described in Table 8 based on the parameter to be checked.

TABLE 8

Parameter	Action
Pause time	Press button T1 and hold it down
"OPEN" function	Press button T2 and hold it down
Motor force	Press button T3 and hold it down

4 Release the button when the flashing light starts flashing.

5 Count the flashes and, based on their number, check the corresponding value in table 7.

Example: If the flashing light flashes three times after you have pressed T1 and T2 for 5s and then button T1, the pause time is set at 60s.

5.2 – OPTIONAL ACCESSORIES

In addition to the devices featured in GD0, other ones are available as optional accessories designed to enhance the automation system and improve its safety and performances.

GA1: OSCILLATING ARM accessory that enables the system to open overhead-type doors.

GU1: MANUAL RELEASE KIT accessory that enables the manual opening of the door even in the event of power failures.

For information on the new accessories, refer to the MHOUSE catalogue or visit the site www.mhouse.biz.

5.3 – ADDING OR REMOVING DEVICES

Devices can be added to or removed from the GDO automation system at any time.

Do not add any devices until you have made sure that they are perfectly compatible with GDO; for further information contact MHOUSE Customer Service.

5.3.1 – Phototest output

This control unit is equipped with the “Phototest” function that increases the reliability of the safety devices, making it possible to achieve “category 2” according to the EN 954-1 (edit. 12/1998) regarding the control unit and safety photocells.

Whenever a manoeuvre is begun, the relative safety devices are checked and only if everything is in order will the manoeuvre start. If the test has a negative outcome (photocell blinded by the sun, short-circuited cable etc.), the fault is recognised and the manoeuvre is not performed.

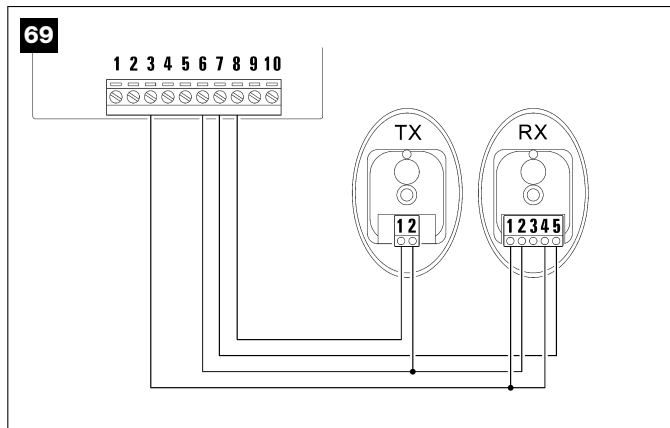

To add a pair of photocells, remove the jumper and connect as follows.

The photocell transmitter power is taken between terminals 8-6 of the “Phototest” output and not from the services output. The maximum current that can be used on the “Phototest” output is 100mA.

Activate the synchronism as described in the Photocell instructions, in the event there are two pairs of photocells that could interfere with one another.

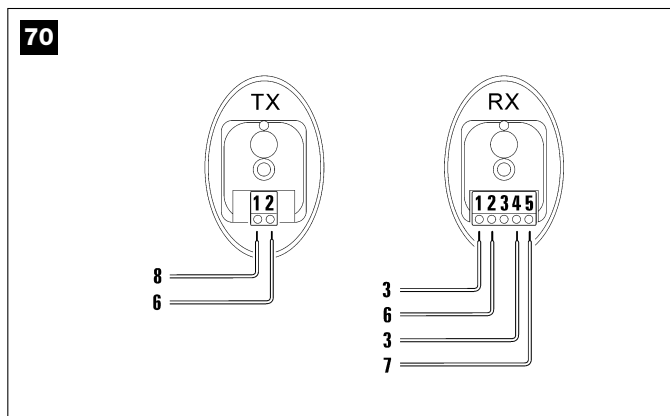

5.3.2 – STOP Input

STOP is the input that causes the immediate interruption of the manoeuvre (with a short reverse run). Devices with output featuring normally open “NO” contacts (like the KS1 selector switch) and devices with normally closed “NC” contacts, as well as devices with 8.2KΩ constant resistance output, like sensitive edges, can be connected to this input. Multiple devices, even of different type, can be connected to the STOP input if suitable arrangements are made.

To do this, proceed as described in the following table:

TABLE 9

second device type:	1 st device type:		
	NO	NC	8,2 KΩ
NO	In parallel (<i>note 2</i>)	(<i>note 1</i>)	In parallel
NC	(<i>note 1</i>)	In series (<i>note 3</i>)	In series
8,2KΩ	In parallel	In series	(<i>note 4</i>)

Note 1. The NO and NC combination can be obtained by placing the two contacts in parallel, and placing in series to the NC contact an 8.2KΩ resistance (therefore, the combination of 3 devices is also possible: NO, NC and 8.2KΩ).

Note 2. Any number of NO devices can be connected to each other in parallel.

Note 3. Any number of NC devices can be connected to each other in series.

Note 4. Only two devices with 8.2KΩ constant resistance output can be connected in parallel; if needed, multiple devices must be connected “in cascade” with a single 8.2KΩ termination resistance.

Warning: if the STOP input is used to connect devices with safety functions, only the devices with 8.2KΩ constant resistance output guarantee the fail-safe category 3.

During the recognition stage of the opening and closing positions of the door, the control unit recognizes the type of device connected to the STOP input; subsequently it commands a STOP whenever a change occurs in the recognized status.

5.4 – MEMORIZATION OF RADIO TRANSMITTERS

The control unit contains a radio receiver for TX4 transmitters; the one included in the package is pre-memorized and operative. If you wish to memorize a new radio transmitter you have two choices:

• **Mode 1:** in this “mode” the radio transmitter is used to its fullest extent, i.e. all the buttons execute a pre-established command (the transmitter supplied with GDO is memorized in Mode 1). It is obvious that in Mode 1 a radio transmitter can be used to command a single automation, i.e.:

Button T1	“OPEN” command
Button T2	“Partial opening” command
Button T3	“Open only” command
Button T4	“Close only” command

• **Mode 2:** one of the four commands available can be associated to each button. This mode, used properly, allows you to command 2 or more different automations; for example:

Button T1	“Open only” command automation N° 1
Button T2	“Close only” command automation N° 1
Button T3	“OPEN” command automation N° 2
Button T4	“OPEN” command automation N° 2

Each transmitter is, of course, a separate unit, and while some are memorized in mode 1 others can be memorized in mode 2 on the control unit.

The overall memory capacity is 150 units; memorization in mode 1 takes up one unit for each transmitter while mode 2 takes up one unit for each button

Warning: since the memorization procedures are timed (10s), you must read the instructions in the following paragraphs before you proceed with their execution.

5.4.1 – Memorization Mode 1

1 Press button P1 [B] for at least 3s.

When the P1 LED [A] goes off, release the button.

2 Within 10s, press any button on the radio transmitter to be memorized and hold it down for at least 3s.

If the memorization procedure is successful, the “P1” LED will flash 3 times.

3 If there are other transmitters to be memorized, repeat step 2 within the next 10s, otherwise the memorization stage will terminate automatically.

71

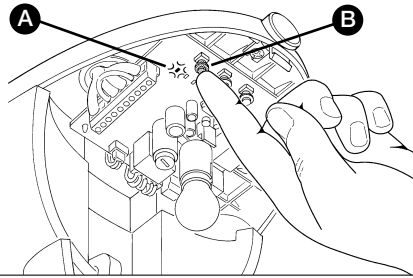

5.4.2 – Memorization Mode 2

With the memorization in mode 2 of the radio transmitter, any one of the four commands (“OPEN”, “Open partially”, “Open only” and “Close only”) can be associated to each button.

In Mode 2 each button requires a separate memorization stage.

1 Press button P1 (figure 71) on the control unit as many times as the number corresponding to the desired command, according to the following table:

1 time	“OPEN” command
2 times	“Partial opening” command
3 times	“Open only” command
4 times	“Close only” command

2 Make sure that the P1 LED makes as many quick flashes as the number corresponding to the selected command.

3 Within 10 s, press the desired button on the radio transmitter to be memorized, and hold it down for at least 2 s.

If the memorization procedure is successful, the “P1” LED will flash 3 times slowly.

4 If there are other transmitters to be memorized for the same type of command, repeat step 3 within the next 10s, otherwise the memorization stage will terminate automatically.

5.4.3 – Remote memorization

A new radio transmitter can be memorized in the control unit without directly operating the buttons on it. You need to have an “OLD” pre-memorized operational radio transmitter. The “NEW” radio transmitter to be memorized will inherit the characteristics of the OLD one, i.e. if the OLD radio transmitter was memorized in Mode 1, the NEW one will also be memorized in Mode 1. In this case, during the memorization stage you can press any key on the two transmitters. If, on the other hand, the OLD transmitter was memorized in Mode 2 you must press the button on the OLD transmitter which corresponds to the desired command, and the button on the NEW transmitter to which you wish to associate that command.

Holding the two transmitters, position yourself within the operating range of the automation and perform the following operations:

1 Press the button on the NEW radio transmitter and hold it down for at least 5s, then release it.

2 Press the button on the OLD radio transmitter 3 times slowly.

3 Press the button on the NEW radio transmitter once slowly.

At this point the NEW radio transmitter will be recognized by the control unit and will assume the characteristics of the OLD one.

If there are other transmitters to be memorized, repeat all the steps above for each new transmitter.

5.4.4 – Deleting a Radio Transmitter

Only if the system features a radio transmitter, you can delete it from the memory by proceeding as follows.

If the transmitter is memorized in Mode 1, only one deletion procedure will be needed and at step 3 you can press any button. If the transmitter is memorized in Mode 2, one deletion procedure will be needed for each key memorized.

1 Press the P1 button [B] (figure 71) on the control unit and hold it down.

2 Wait until the P1 LED [A] lights up, then, within three seconds:

3 Press the key on the radio transmitter to be deleted and hold it down for at least three seconds. If the deletion procedure is successful, the P1 LED will flash rapidly five times. If the P1 LED flashes only once slowly, it means that the deletion procedure has not been successful because the transmitter is not memorized.

4 If there are other transmitters to be deleted, press the P1 key and repeat step 3 within ten seconds, otherwise the deletion procedure will be terminated automatically.

5.4.5 – Deleting all the Radio Transmitters

With this operation all the memorized transmitters are deleted.

1 Press the P1 button [B] on the control unit and hold it down.

2 Wait until the P1 LED [A] lights up, then wait until it goes off, then wait until it has flashed 3 times.

3 Release the P1 button precisely upon the third flash.

4 Wait approximately 4 s for the deletion process to be completed; during this time the LED will flash very quickly.

If the procedure is successful, after a few moments the “P1” LED will flash slowly 5 times.

72

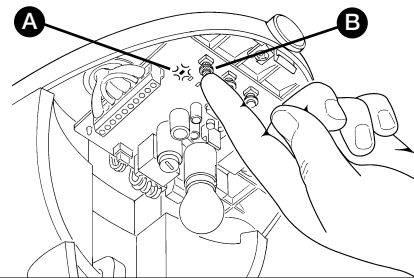

5.5 – TROUBLESHOOTING

The following table contains instructions to help you solve malfunctions or errors that may occur during the installation stage or in case of failure.

TABLE 10

Symptoms	Probable cause and possible solution
The radio transmitter does not emit any signal (the LED [A] does not light up)	<ul style="list-style-type: none"> Check to see if the batteries are exhausted, if necessary replace them (paragraph 7.3.4 “Replacing the Remote Control Battery”).
The manoeuvre does not start and the LED OK LED [B] does not flash	<ul style="list-style-type: none"> Make sure that the power cord is properly plugged into the mains outlet Check to see if the fuses [D] or [E] are blown; if necessary, identify the reason for the failure and then replace the fuses with others having the same current rating and characteristics.
The manoeuvre does not start and the courtesy light [F] is off.	<ul style="list-style-type: none"> Make sure that the commands are actually received. If the command correctly arrives to the control unit, the “OK” LED will make two long flashes.
The manoeuvre does not start and the courtesy light flashes a few times.	<ul style="list-style-type: none"> Make sure that the STOP input is active, i.e. that the “STOP” LED [C] comes on. If this does not happen, check the devices connected to the STOP input. The photocell test which is performed at the starting of each manoeuvre is not successful; check the photocells, also according to Table 11 (Paragraph 5.6.1 “Photocells”).
The manoeuvre starts but inverts immediately	<ul style="list-style-type: none"> The selected force is too low to move the door. Check for possible obstacles and if necessary select a higher force as described in chapter 5.1 “Advanced adjustments”.
The manoeuvre is carried out but the flashing light does not work	<ul style="list-style-type: none"> Make sure that there is voltage between the flashing light terminals 9 and 10 (being intermittent, the voltage value is not important: approximately 10-30Vac); if there is voltage, the problem is due to the lamp; in this case replace the lamp with one having the same characteristics.
The manoeuvre is carried out but the courtesy light does not work.	<ul style="list-style-type: none"> Replace the lamp [F] with one having the same characteristics.

73

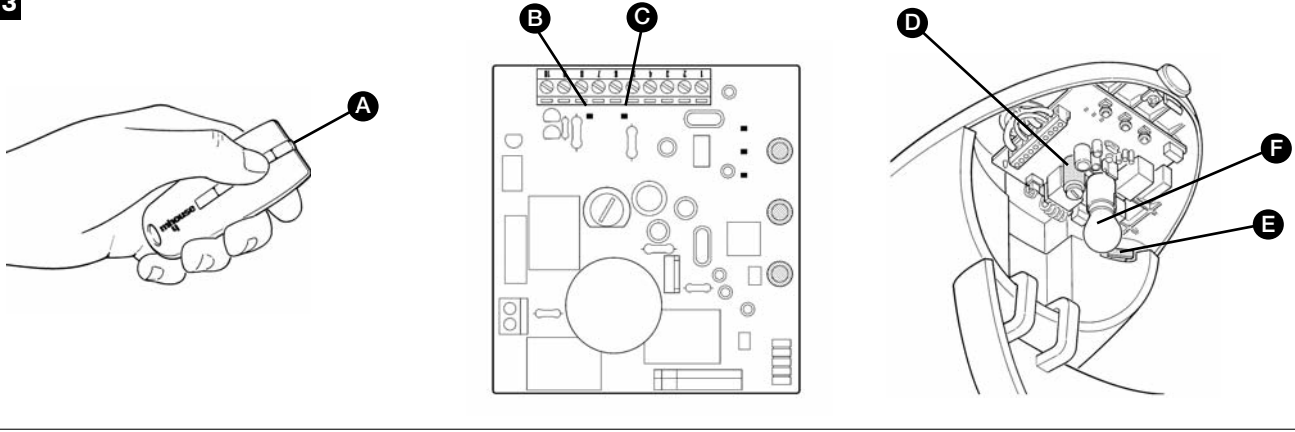

5.6 – DIAGNOSTICS AND SIGNALS

A few devices issue special signals that allow you to recognize the operating status or possible malfunctions.

5.6.1 – Photocells

The photocells are equipped with a “SAFE” LED [A] (Figure 74) that allows you to check the operating status at any time.

74

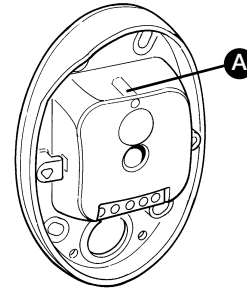

TABLE 11

“SAFE” LED	MEANING	STATUS OUTPUT	ACTION
Always Off	Signal OK= No obstacle	Active	All OK
Slow flash	Weak signal = No obstacle	Active	Improve centring
Rapid flash	Poor signal = No obstacle	Active	Check centring, cleanliness and surroundings
Always on	No signal = Obstacle present	Alarm	Remove obstacle

5.6.2 – Flashing and courtesy lights

During the manoeuvre the flashing light flashes once every second, while the courtesy light is always on; when something is wrong the flashes are

more frequent (half a second); the light flashes twice with a second’s pause between flashes. The diagnostic flashing itself is signalled by the courtesy light.

TABLE 12

Quick flashes	Status	Action
2 flashes 1 second’s pause 2 flashes	Triggering of a photocell	At the starting of the manoeuvre, one or more photocells do not enable it; check to see if there are any obstacles. If there is an obstacle impeding the movement no action is required.
3 flashes 1 second’s pause 3 flashes	Activation of the “motor force” limiting device	During the movement, the door experienced excessive friction; identify the cause.
4 flashes 1 second’s pause 4 flashes	Activation of the STOP input	During the movement the STOP input was activated; identify the cause.

5.6.3 – Control Unit

On the control unit there is a set of LED's each of which can give special indications both during normal operation and in case of malfunctions.

75

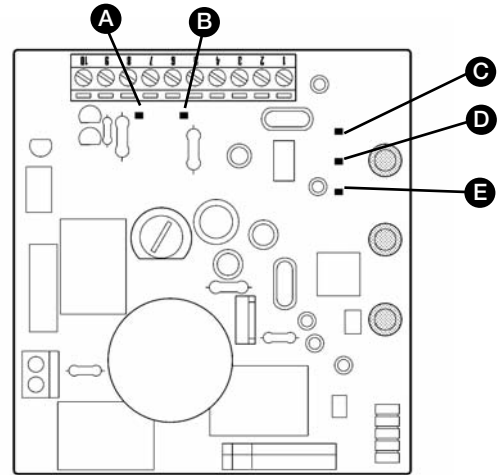

TABLE 13

LED OK [A]	Status	Action
Off	Malfunction	Make sure there is power supply; check to see if there are blown fuses; identify the cause of the malfunction and then replace blown fuses with others having the same characteristics.
On	Serious malfunction	There is a serious malfunction; try switching off the control unit for a few seconds; if the condition persists it means there is a malfunction and the electronic board has to be replaced.
One flash every second	Everything OK	Normal operation of control unit
2 long flashes	The status of the inputs has changed	This is normal when there is a change in one of the inputs: OPEN, STOP, triggering of photocells or the radio transmitter is used.
Series of flashes separated by a pause	It corresponds to the flashing and courtesy light's signal. (See Table 12)	
LED STOP [B]	Status	Action
Off	Cutting in of the STOP input	Check the devices connected to the STOP input
On	Everything OK	STOP input active
One flash every second	No device has been memorized or an error has occurred in the memorised devices	There may be faulty devices; check and, if necessary, try repeating the recognition process (see paragraph 3.5.1 "Recognition of door's opening and closing positions").
LED P1 [C]	Status	Action
Off	Everything OK	No memorization in progress
ON	Memorization in Mode 1	This is normal during memorization in mode 1 which lasts maximum 10s
Series of quick flashes, from 1 to 4	Memorization in Mode 2	This is normal during memorization in mode 2 which lasts maximum 10s
LED P2 [D]	Status	Action
Off	Everything OK	"Slow" speed selected
On	Everything OK	"Fast" speed selected
One flash every second	The recognition phase has not been performed or there is a data error in the memory	Repeat the position recognition procedure again (see paragraph 3.5.1. "Recognition of the door's open and closed positions")
2 flashes per second	Device recognition stage in progress	It indicates that the search for the connected devices is underway (this stage lasts a few seconds at the most)
LED P3 [E]	Status	Action
Off	Everything OK	Cyclic operation
On	Everything OK	Complete cyclic operation
One flash every second	The recognition phase has not been performed or there is a data error in the memory	Repeat the position recognition procedure again (see paragraph 3.5.1. "Recognition of the door's open and closed positions")
2 flashes per second	Position recognition procedure in progress	

TECHNICAL CHARACTERISTICS

STEP 6

The product GD0... is produced by Nice S.p.a. (TV) I. **Mhouse** is a commercial trademark owned by Nice S.p.a.

Nice S.p.a., in order to improve its products, reserves the right to modify their technical characteristics at any time without prior notice. In any case, the manufacturer guarantees their functionality and fitness for the intended purposes.

Note: all the technical characteristics refer to a temperature of 20°C.

Model GD0K	
DESCRIPTION	DATA
Type	Electromechanical gearmotor for automated sectional and overhead doors incorporating a control unit complete with radio receiver for "TX4" transmitters.
Adopted technology	24Vdc motor, helical teeth reduction gear; drive guide with timing belt and mechanical release A transformer inside the motor but separated from the control unit reduces mains voltage to the nominal voltage of 24Vdc used by the automation system.
Peak thrust [corresponds to the force necessary to move a leaf]	9.9Nm [550N]
Nominal torque [corresponds to the force necessary to keep a leaf moving]	4.95Nm [275N]
Speed under no load [corresponds to if "Fast" speed is programmed]	103rpm [0.14m/s] The control unit allows 2 speeds to be programmed equal to approx. 100% - 60%.
Nominal torque speed [corresponds to if "Fast" speed is programmed]	52rpm [0.07m/s]
Maximum frequency of cycles	30 complete cycles per day (the control unit allows up to a maximum of 10 cycles per hour)
Maximum continuous cycle time	4 minutes (the control unit limits the continual function to 4 minutes at nominal torque)
Working Limits	Its structural characteristics make it suitable for use on sectional and overhead door with counterweights within the following parameters: - Sectional doors: 240cm max. high - 300cm (7.2 m ²) max. wide - maximum torque 55kg - Overhead doors: 240cm max. high - 270cm (6.48m ²) max. wide - maximum torque 55kg
Power supply GD0	230Vac (±10%) 50/60Hz
Power supply GD0/V1	120Vac (±10%) 50/60Hz
Max. absorbed power	200W
Insulation class	1 (a safety grounding system is required)
Emergency power supply	---
Flashing light output	For visual signalling devices with 12V lamp, maximum 21W
Courtesy light	12V lamp maximum 10 WBA15 socket (automotive type lamp), stays on 60s after the manoeuvre
"PHOTO" input	For safety devices such as the PH0 photocell
"OPEN" input	For normally open contacts (the closing of the contact causes the "OPEN" command)
"STOP" input	For normally open contacts and/or for 8.2KΩ constant resistance, or normally closed contacts with recognition of the "normal" status (any variation from the memorized status causes the "STOP" command)
Radio aerial input	52Ω for RG58 or similar type of cable
Maximum cable length	Mains power supply: 30m; inputs/outputs: 20m with aerial cable preferably shorter than 5m (observe the directions regarding the minimum gauge and type of cable)
Remote control possibility	with TX4 transmitters, the control unit can receive one or more of the following commands: "OPEN", "Open partially", "Open only" and "Close only"
TX4 transmitters memorized	Up to 150 if memorized in mode 1
Range of TX4 transmitters	From 10 to 50 m without aerial, from 50 to 100 m with aerial incorporated in the FL1 flashing light. The range can vary if there are obstacles or electromagnetic disturbances, and is affected by the position of the receiving aerial incorporated in the flashing light.
Programmable functions	"Cycle" or "Complete cycle" operation (automatic closing) "Slow" or "fast" motor speed. The pause time in the "complete cycle" mode can be set at 15, 30, 60 seconds. The type of pedestrian opening can be selected from 4 modes. The sensitivity of the obstacle detection system can be selected from 3 levels. The operation of the "Open" command can be selected from 3 modes
Self-programmed functions	Automatic detection of the type of "STOP" device (NO or NC contact or 8.2KΩ resistance) Automatic detection of door length and calculation of deceleration points
Operating ambient temperature	-20 ÷ 50°C
Not suitable for use in acid, saline or potentially explosive atmosphere	NO
Mounting	Horizontal
Protection class	IP40
Dimensions / weight	390 x 210 x h 130mm / 3kg

PH0 Photocells (optional)

DESCRIPTION	DATA
Type	Presence detector for automated gates and doors (type D according to EN standard 12453) consisting of a "TX" transmitter and an "RX" receiver.
Adopted technology	Optical, by means of direct TX-RX interpolation with modulated infrared ray.
Detection capacity	Opaque objects located on the optical axis between TX and RX, larger than 50mm and moving slower than 1.6m/s
TX transmission angle	approx. 20°
RX reception angle	approx. 20°
Useful capacity	Up to 10m for maximum TX-RX misalignment of $\pm 5^\circ$ (the device can signal an obstacle even in the case of adverse weather conditions)
Power supply/output	without jumper 24Vac/Vcc limits 18-35Vcc, 15-28Vac with jumper 12Vac/Vcc limits 10-18Vcc, 9-15Vac
Maximum absorption	25 mA RX, 30mA TX = 55 mA per torque
Maximum cable length	Up to 20 m (observe the directions regarding the minimum gauge and type of cable)
Operating ambient temperature	-20 ÷ 50°C
Use in acid, saline or potentially explosive atmosphere	No
Mounting	Vertical, wall-mounted
Protection class	IP44
Dimensions / weight (TX e RX)	95 x 65 h 25mm / 65g

KS1 Key-Operated Selector Switch (optional)

DESCRIPTION	DATA
Type	Key-operated double switch suitable for control of automatic gates and doors. Illuminated for night operation.
Adopted technology	Activation protected by a lock, the insertion and clockwise turning of the key causes the closing of a contact, the counter-clockwise turning of the key causes the closing of the second contact; spring-loaded for return of key to the middle position.
Tamper-proof	II The selector switch can be opened to access the connections only by inserting the key and turning it in either direction.
Security lock	Key with 450 different key numbers.
Power supply/contacts	The device can only be connected to the "OPEN" input terminals 3-4 and 5-6 "STOP" of the MHOUSE automation control units to which the command signals are sent and draws the power supply for night lighting.
Operating ambient temperature	-20 ÷ 50°C
Use in acid, saline or potentially explosive atmosphere	NO
Mounting	Vertical, wall-mounted
Protection class	IP44
Dimensions / weight	95 x 65 h 36mm / 135g

FK1 Flashing light (optional)

DESCRIPTION	DATA
Type	Flashing signalling light for automatic gates and doors. The device incorporates a receiving aerial for remote control.
Adopted technology	Visual signalling device with 12V 21W lamp, controlled by MHOUSE automation control units.
Lamp	12V 21W BA15 socket (automotive type lamp).
Power supply/contacts	The device can only be connected to the "FLASH" output terminals 9-10 and "ARIEL" input 1-2 of the MHOUSE automation control units.
Operating ambient temperature	-20 ÷ 50°C
Use in acid, saline or potentially explosive atmosphere	NO
Mounting	Horizontal surface-mounted or vertical wall-mounted
Protection class	IP44
Dimensions / weight	120 x 60 h 170mm / 285g

TX4 transmitters

DESCRIPTION	DATA
Type	Radio transmitters for remote control of automatic sectional and overhead doors
Adopted technology	AM OOK coded modulation of radio carrier
Frequency	433.92 Mhz
Coding	Rolling code with 64 Bit code (18 billion million combinations)
Buttons	4, each button sends a command and can be used for the different controls of the same control unit or to control different control units.
Irradiated power	approx. 0,0001W
Power supply	6V +20% -40% with two CR2016 type lithium batteries
Battery life	3 years, estimated on the basis of 10 commands/day, each lasting 1s at 20°C (at low temperatures the efficiency of the batteries decreases)
Operating ambient temperature	-20 ÷ 50°C
Use in acid, saline or potentially explosive atmosphere	No
Protection class	IP40 (suitable for use indoors or in protected environments)
Dimensions / weight	72 x 31 h 11mm / 18g

STEP 7

This guide should be stored in an accessible location and made available to all users of the automation.

7.1.1 – Safety regulations

- Keep an eye on the moving door and keep at a safe distance until the door has completely opened or closed; do not cross the opening until the door has completely opened and stopped.
- Do not allow children to play near the door or with its controls.
- Keep the transmitter out of the reach of children.
- Stop using the automation system immediately if you notice anything abnormal (strange noise or jerky movements); failure to observe this warning may result in serious danger and accidents.
- Do not touch any components while they are moving.
- Have periodic checks made according to the instructions provided in the maintenance schedule.
- Maintenance operations and repairs can only be performed by qualified technicians.

7.1.2 – Door Control

With radio transmitter

The radio transmitter is ready for use and the four buttons have the following functions:

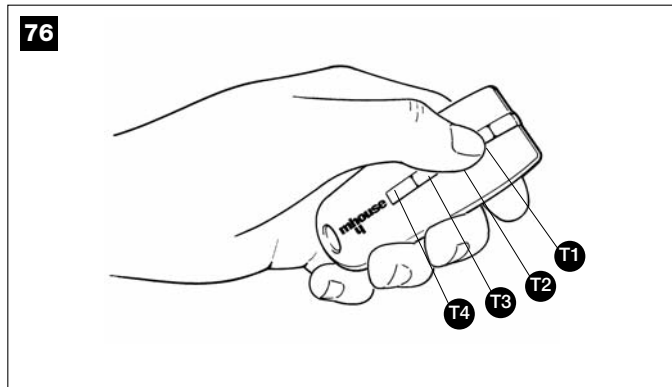

Function (*)	
T1 Button	
T2 Button	
T3 Button	
T4 Button	

(*) This table must be prepared by the person who has programmed the system:

With selector switch (optional accessory)

The selector switch has two positions, with automatic return to the centre.

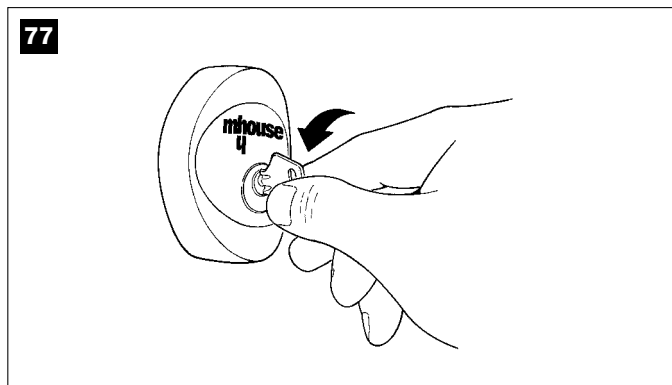

Action	Function
Rotated to the right: "OPEN"	(*)
Rotated to the left: "STOP"	It stops the movement of the sectional or overhead door

(*) This item must be drafted by the person who has programmed the system.

Control with safety devices out of order

If the safety devices are out of order or malfunctioning, it is still possible to control the door.

1 Operate the gate control device (remote control or key-operated selector switch). If the safety devices enable the operation, the door will open normally, otherwise: actuate the control again within 3 seconds and keep it actuated.

2 After approximately 2s the gate will start moving in the "man present" mode, i.e. so long as the control is maintained the gate will keep moving; as soon as the control is released the door will stop.

If the safety devices are out of order the automation must be repaired as soon as possible.

Gearmotor release

The gearmotor is equipped with a mechanical system which allows the door to be opened and closed manually (i.e. as if GD0 were not present).

The manual operation must be resorted to in case of power failures or system malfunctions.

- 1 Pull the release cord until you hear the carriage being released.
- 2 At this point you can move the door manually.
- 3 To restore the functionality of the automation system, move the door back in position until you hear the carriage being engaged.

The activation of the manual release may cause an uncontrollable movement of the door if the springs are weak or broken, or if the door is off-balance.

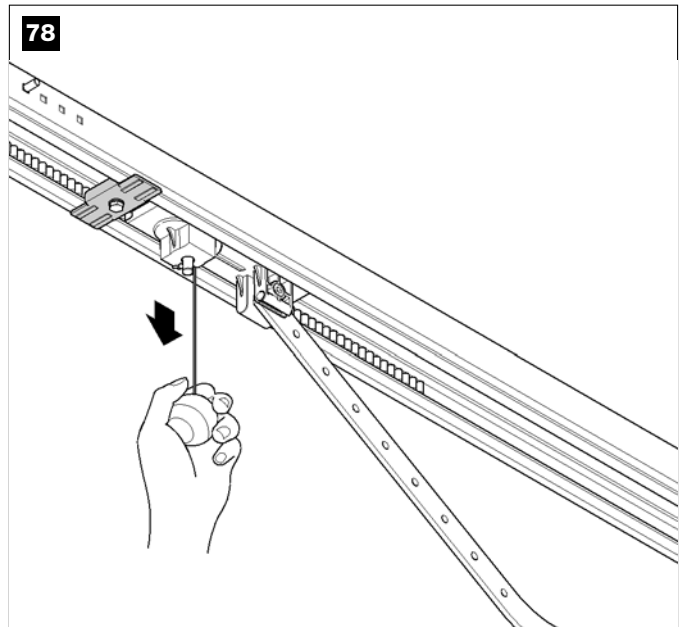

7.1.3 – Maintenance Operations to Be Performed by the User

The operations that must be periodically performed by the user are listed below.

- Use a slightly damp cloth (not wet) to clean the surface of the devices. Do not use any substances containing alcohol, benzene, diluents or other flammable substances. The use of these substances could damage the devices, start fires or generate electric shocks.

- Disconnect the power supply to the automation before you proceed to remove leaves and debris, to prevent anyone from activating the door.

- Periodically check the system, especially cables, springs and supports, for possible imbalance or signs of wear or damage. Do not use the automation system if repair or adjustment is necessary, in as much that a fault or an incorrectly balanced door could cause injury.

7.1.4 – Replacing the Remote Control Battery

If the range of the remote control is significantly diminished and the light emitted by the LED is feeble, the remote control battery is probably exhausted. The remote control houses two CR2016 type lithium batteries. To replace them proceed as follows:

1 Open the bottom by pulling it.

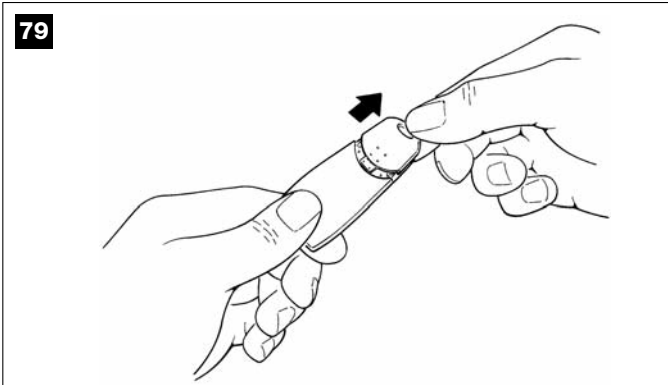

2 Insert a small pointed tool in the slit and prise the batteries out.

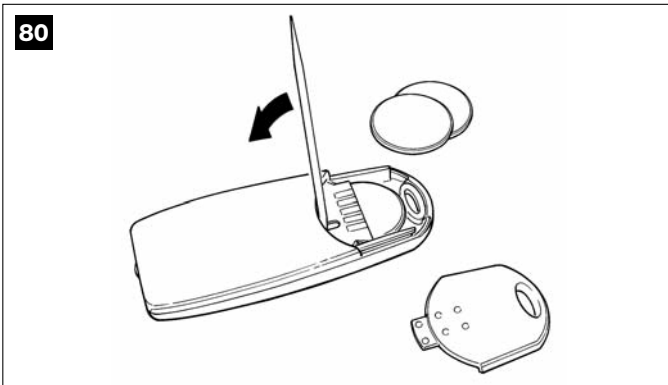

3 Insert the new battery, observing the polarity (the “+” symbol towards the bottom).

4 Close the bottom until it clicks.

The batteries contain polluting substances: do not dispose of them together with other waste but use the methods established by local regulations.

7.1.5 – Lamp replacement

Before proceeding, disconnect GD0 from the power supply.

1 Unscrewing screw [A] and pushing button [B], open the lid.

2 Push the lamp up and rotate to remove. Insert a new 12V / 10W lamp with BA15 socket.

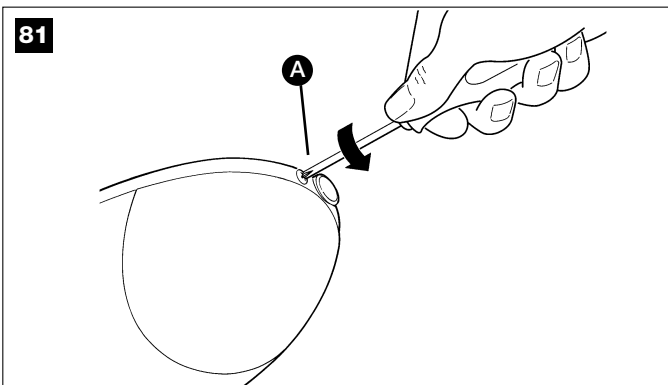

82

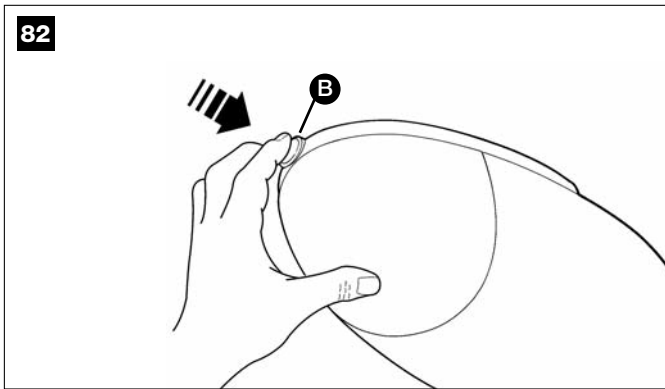

83

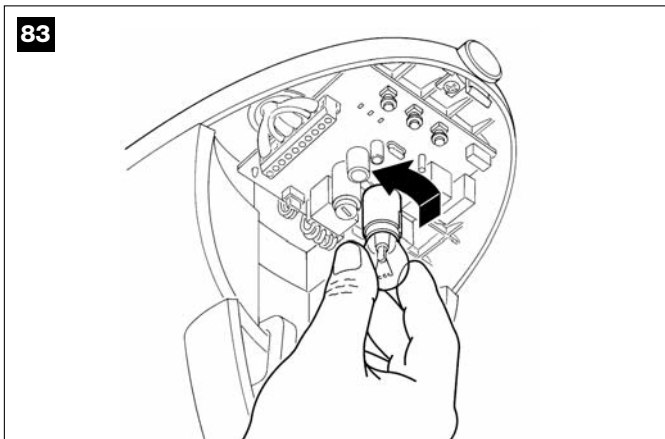

CE declaration of conformity and declaration of incorporation of 'partly completed machinery'

Declaration in accordance with the Directives: 1999/5/EC (R&TTE), 2006/95/EC (LVD); 2004/108/EC (EMC); 2006/42/EC (MD)

GDO is produced by NICE S.p.a. (TV) I; MHOUSE is a commercial trademark owned by Nice S.p.a

Note - The contents of this declaration correspond to declarations in the official document deposited at the registered offices of Nice S.p.a. and in particular to the last revision available before printing this manual. The text herein has been re-edited for editorial purposes. A copy of the original declaration can be requested from Nice S.p.a. (TV) I.

Number: 213/GDO

Revision: 2

Language: EN

Manufacturer's Name:

NICE S.p.A.

Address:

Via Pezza Alta n° 13, 31046 Rustignè di Oderzo (TV) Italy

Person authorised to draw up technical documentation:

Mr. Oscar Marchetto

Type of product:

electromechanical gearmotor with built-in control unit

Model / Type:

GDO

Accessories:

TX4, PH0, KS1, FL1

The undersigned, Luigi Paro, in the role of Managing Director, declares under his sole responsibility, that the product specified above conforms to the provisions of the following directives:

- DIRECTIVE 1999/5/EC OF THE EUROPEAN PARLIAMENT AND COUNCIL of 9 March 1999 regarding radio equipment and telecommunications terminal equipment and the mutual recognition of their conformity according to the following harmonised standards:
 - Health protection: EN 50371:2002;
 - Electrical safety: EN 60950-1:2006
 - Electromagnetic compatibility: EN 301 489-1 V1.8.1:2008; EN 301 489-3 V1.4.1:2002
 - Radio range: EN 300 220-2 V2.3.1:2010
- Directive 2006/95/EC OF THE EUROPEAN PARLIAMENT AND COUNCIL of 12 December 2006 regarding the approximation of member state legislation related to electrical material destined for use within specific voltage limits, according to the following harmonised standards:
EN 60335-1:2002 + A1:2004 + A11:2004 + A12:2006 + A2:2006 + A13:2008
EN 60335-2-95:2004
- DIRECTIVE 2004/108/EC OF THE EUROPEAN PARLIAMENT AND COUNCIL of 15 December 2004 regarding the approximation of member state legislation related to electromagnetic compatibility, repealing directive 89/336/EEC, according to the following standards:
EN 61000-6-2:2005, EN 61000-6-3:2007

The product also complies with the following directives according to the requirements envisaged for "quasi machinery":

Directive 2006/42/EC THE EUROPEAN PARLIAMENT AND COUNCIL of 17 May 2006 regarding machinery and which amends directive 95/16/EC (recasting) according to the following harmonised standards:

- It is hereby declared that the pertinent technical documentation has been compiled in compliance with appendix VII B of directive 2006/42/EC and that the following essential requirements have been observed: 1.1.1- 1.1.2- 1.1.3- 1.1.5- 1.2.1- 1.2.2- 1.2.6- 1.3.1- 1.3.2- 1.3.3- 1.3.4- 1.3.7- 1.4.3- 1.5.1- 1.5.4- 1.5.5- 1.5.6- 1.5.7- 1.5.8- 1.5.10- 1.5.11- 1.5.13-1.5.14- 1.5.15- 1.5.16- 1.6.1- 1.6.2- 1.6.3- 1.6.4- 1.7.1- 1.7.1.1- 1.7.1.2- 1.7.3- 1.7.4- 1.7.4.1- 1.7.4.2- 1.7.4.3.
- The manufacturer undertakes to transmit to the national authorities, in response to a motivated request, all information regarding the "quasi-machine", while maintaining full rights to the related intellectual property.
- Should the "quasi machine" be put into service in a European country with an official language other than that used in this declaration, the importer is obliged to arrange for the relative translation to accompany this declaration.
- The "quasi-machine" must not be used until the final machine in which it is incorporated is in turn declared as compliant, if applicable, with the provisions of directive 2006/42/EC.

The product also complies, within the constraints of applicable parts, with the following standards:

EN 13241-1:2003, EN 12445:2002, EN 12453:2002, EN 12978:2003

Oderzo, 17.03.10

Luigi Paro
(Managing Director)



DICHIARAZIONE CE OF CONFORMITY

According to Directive 2006/42/CE, ANNEXE II, part A (CE declaration of conformity for machines)
This document must be printed in the official language of the country where the product is installed.

The undersigned / Company

(company name of the person responsible for commissioning of the power-operated sectional or up-and-over door)

(address)

Declares under his/her sole responsibility that:

The automation: power operated sectional
 overhead door

Serial number: _____

Year of manufacture: _____

Location (address): _____

it complies with all provisions concerning the following directives:

2006/42/CE Machine Directive
2004/108/CE Electromagnetic Compatibility Directive
2006/95/CE Low Voltage Directive
99/5/CE "R&TTE" Directive

and the provisions of the following harmonised standards:

EN 12445 "Industrial, commercial and garage doors and gates.
Safety in use of power operated doors - Test methods"
EN 12453 "Industrial, commercial and garage doors and gates.
Safety in use of power operated doors - Requirements"

Name _____ **Signature** _____
(of the person authorised to write the declaration)

Date _____ **Location** _____

Name _____ **Address** _____
(of the person authorised to prepare the technical documentation)



Mhouse is a commercial trademark owned by Nice S.p.a.

Nice S.p.a.
Via Pezza Alta, 13 - Z.I. Rustignè
31046 Oderzo (TV), Italia
Tel. +39 0422 20 21 09
Fax +39 0422 85 25 82

