

Model 700/727/750/757 S & J & 700-240 date from 70's to approx. 1989.

Check the serial # if the unit is pre 83 **NO PARTS ARE AVAILABLE.**

If newer than 83 warn the customer of parts being obsolete.

The following parts are available at this time 8/9/00, check inventory before committing to availability. When our inventory is depleted the parts will be considered obsolete/NLA.

Homeowner's Installation and operation manual

\$1.50

THIS OWNER'S MANUAL CONTAINS COMPLETE INSTRUCTIONS FOR INSTALLATION, AND MAINTENANCE OF THIS GARAGE DOOR OPERATOR SYSTEM. IT SHOULD BE MOUNTED NEAR THE INSTALLATION IN A PROMINENT POSITION.

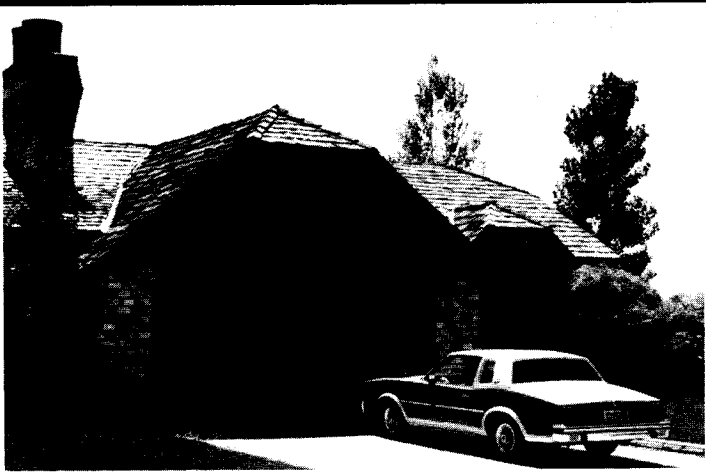
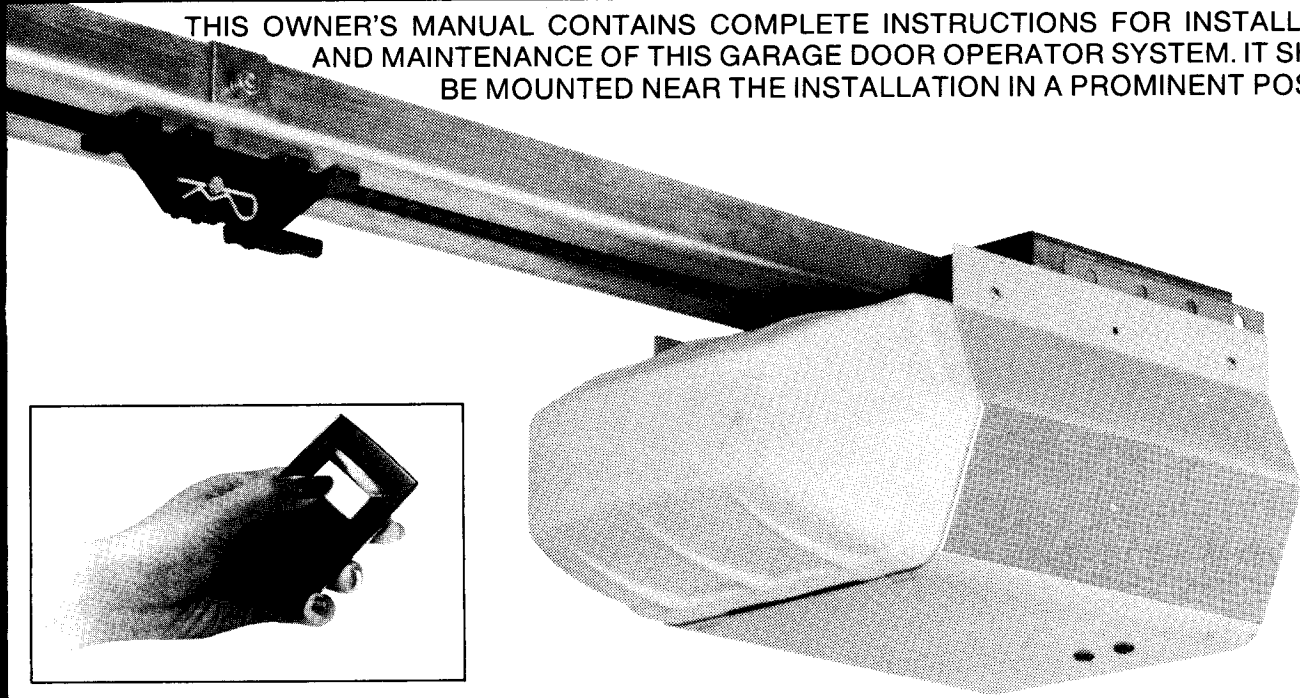

Moore-O-Matic, Inc. A Nortek Company

Quality Garage Door Systems

Chain-drive opener

Models 700, 727, 750, 700-240, and 757

WARNING

To reduce the risk of injury to persons — Use this operator with:
SECTIONAL DOOR
ONE PIECE JAMB DOOR

REPLACEMENT PARTS LIST

MODEL 700/727/750/757 S & J AND 700-240 EXPLODED VIEW OPERATOR HEAD ASSEMBLY

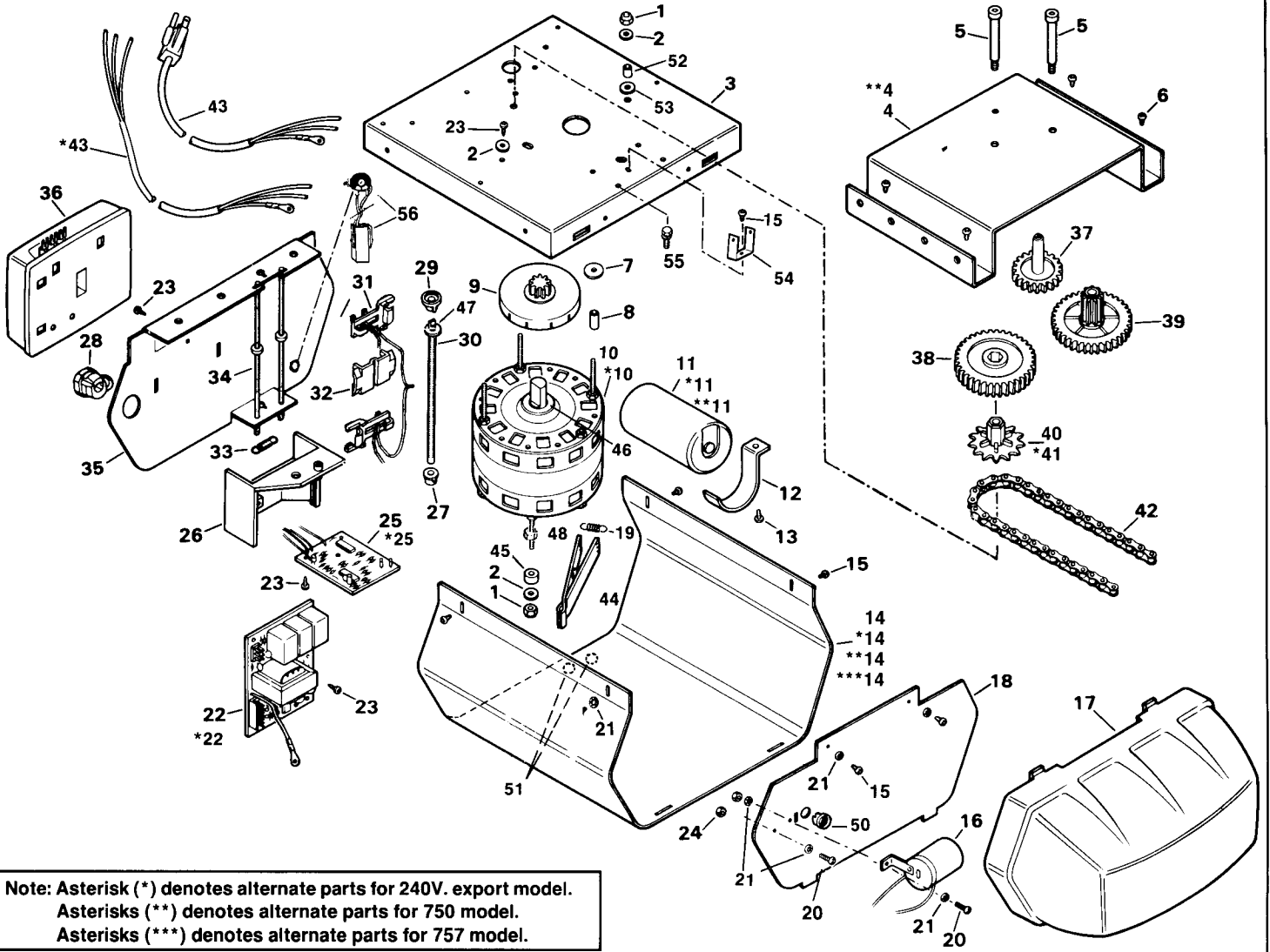

REF.	PART NO.	DESCRIPTION	QTY.	REF.	PART NO.	DESCRIPTION	QTY.	REF.	PART NO.	DESCRIPTION	QTY.
1	A7826	#10-32 NYLOCK HEX NUT LP	4	17	8311-000	LIGHT LENS	1	37	A6720	LIMIT GEAR	1
2	7849-000	#10 FLAT WASHER	5	18	A6716	FRONT PLATE	1	38	A6721	38 TOOTH GEAR	1
3	A6748	CHASSIS	1	19	A7104	SPRING	2	39	A6723	36/9 TOOTH GEAR	1
4	A6710	COVER, GEAR	1	20	7564-000	#6-32x7/16 PN HD PH SCREW	2	40	A6728	9 T. SPROCKET (JAMB)	1
**4	A7851	COVER, GEAR 750 BLACK	1	21	7832-000	#6 INT TOOTH LOCK WASHER	4	*41	A6724	13 T. SPROCKET (SECT., 240V.)	1
5	A6739	5/16x1-3/4 STRIPPER BOLT	2	22	A7608	CONTROLLER, L411R BOARD	1	42	A6753	15.5 IN CHAIN	1
6	A7795	#8-32x3/8 PN HD PH TYPE D SCREW	4	*22	A7639	CONTROLLER, L411-R2 (240 V.)	1	43	B5731	POWER CORD ASSY. 56"	1
7	A3728	.203x.750x.062 FLAT WASHER	3	23	A6786	#8x3/8 PN HD SCREW	4	*43	A6973	POWER CORD ASSY. (240V.) 48"	1
8	A7266	SPACER .75 LG	3	24	7202-000	#6-32 HEX NUT	2	44	A7092	BRAKE ARM ASSY.	2
9	A6725	9-TOOTH PINION GEAR	1	25	A7767	TORQUE SENSOR ASSY. ADJ.	1	45	A6935	NYLON SPACER .50 OD x .19 ID	1
10	A6732	1000 RPM MOTOR	1	*25	A7649	TORQUE SENSOR ASSY. (240 V.)	1	46	A7084	NYLON WASHER	AR
*10	A7177	625 RPM MOTOR 240V.	1	26	A6726	RETAINER	1	47	A7095	RING, EXT. PUSH-ON .374 ID	1
11	A6993	43-53 MFD CAPACITOR	1	27	B5588	.22 ID C.E. KEYED BEARING	1	48	7205-000	NUT, #10-32 HEX	1
*11	A7433	15 MFD MEPCO 370 V.	1	28	A5409	.875 OD STRAIN RELIEF	1	50	B6161	BUSHING .375 ID, SNAP	1
**11	6026-000	53-64 MFD CAPACITOR	1	29	B5587	.22 ID KEYED BEARING	1	51	A6741	GROMMET .187 ID x .312 OD	2
12	A6737	CAPACITOR BRACKET	1	30	B5663	LIMIT SHAFT	1	52	A7265	SPACER .25 LG	3
13	A7023	#10x3/8 PN HD PHLP SCREW	1	31	A7765	LIMIT SWITCH ASSEMBLY	1	53	A7268	GROMMET .312 ID x .625 OD	3
14	A6630	WRAP COVER (TAN) 727 Ser.	1	32	A7226	LIMIT SWITCH TRAVELER	1	54	A6735	BRACKET, CH RETAINER	1
*14	A6631	WRAP COVER (GRAY) 700 Ser.	1	33	B6078	SPRING	1	55	A7604	1/4-20 x 1/2 SEMS BOLT	4
**14	A7854	WRAP COVER (BLUE) 750 Ser.	1	34	B6526	LIMIT ADJUST SCREW	2	56	A7760	POT ASSEMBLY	1
***14	A7917	WRAP COVER (RUST) 757 Ser.	1	35	A6749	BACK PLATE ASSY.	1				
15	A6937	#6x1/4 PN HD PHLP SCREW	10	36	DNR009	REC DRNR (Domestic Only)	1				
16	A4906	LAMP HOLDER	1								

AR=As Required

REPLACEMENT PARTS LIST

RR 700 MODEL SERIES S & J EXPLODED VIEW OPERATOR CHANNEL ASSEMBLY

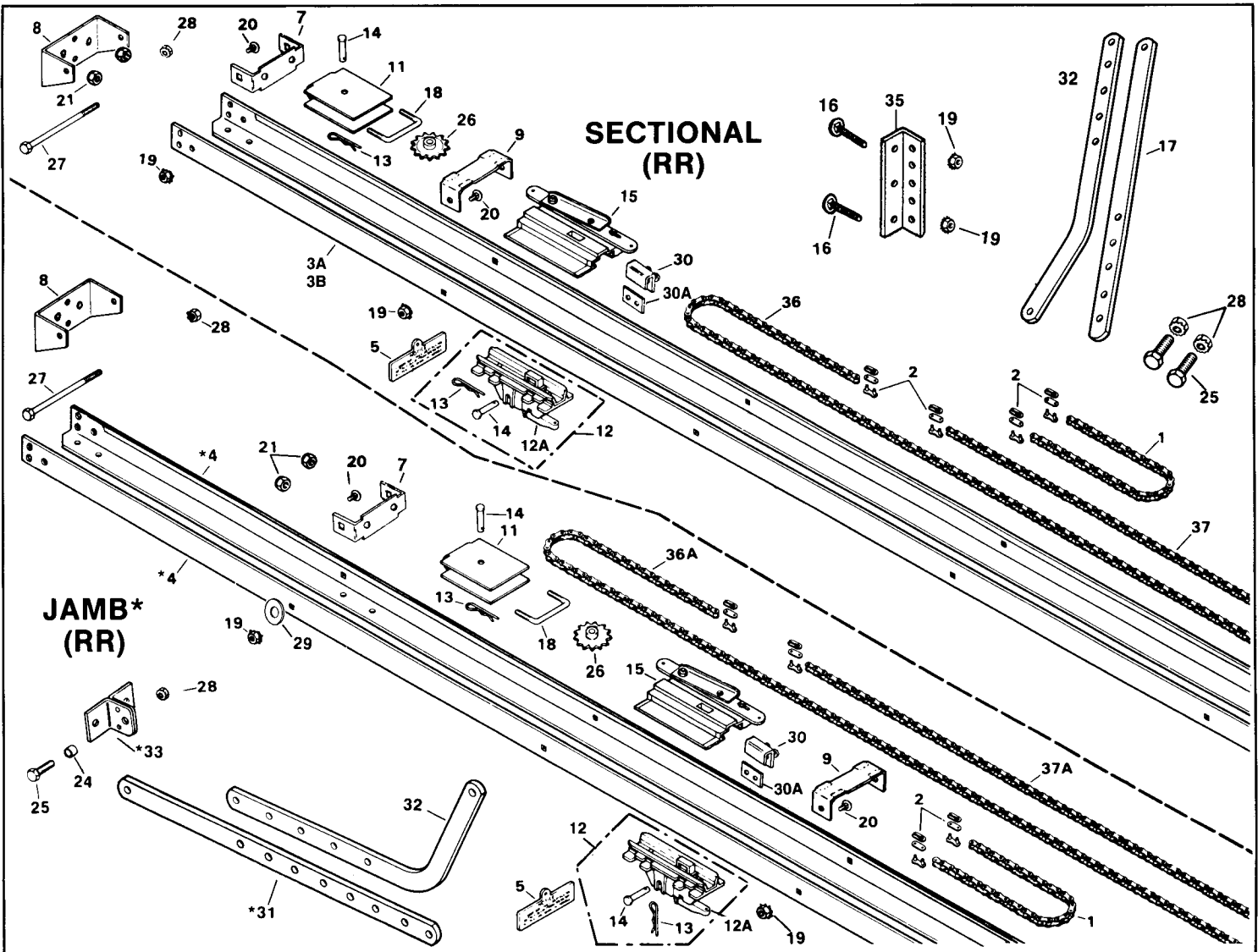

REF.	PART NO.	DESCRIPTION	QTY.
1	A6753	CHAIN, 15.5" (SHIPPED WITH HEAD ASSEMBLY)	1
2	8526-000	MASTER LINK	4
3A	A7870	CHANNEL SECT. (SECT'L), 113.5" HEMMED	2
3B	A7901	CHANNEL SECT. (8" SECT'L) 126.125" HEMMED	2**
*4	A7871	CHANNEL SECT. (JAMB), 90" HEMMED	2
5	A6577	TROLLEY RELEASE HANDLE	1
7	A7875	CHANNEL ADJUST BRACKET	1
8	A7952	HEADER BRACKET	1
9	A7790	SPREADER BRACKET	(3-4)**
11	A7216	IDLER SPROCKET RETAINER	1
12	A7805	TROLLEY SLIDE ASSY. COMPLETE	1
12A	A7207	LATCH REPLACEMENT KIT	1
13	7311-000	#3 HITCH PIN	2
14	7330-000	5/16 x 1-1/8 CLEVIS PIN	2
15	A7809	TROLLEY ASSY. (NO CHAIN)	1
		TROLLEY ASSYS. (CHAIN INCLUDED):	1
	A7957	(WITH 121.5" + 86.5")	
	A7958	(WITH 134.5" + 98.5")	
*	A7814	(WITH 54.5" + 75.5")	
16	7100-000	1/4-20 X 2" FULL THD CARR BOLT	2
17	A6801	17" STRAIGHT DOOR ARM (SHIPPED WITH HEAD ASSEMBLY)	1
18	A6702	U-BOLT	1
19	A7603	1/4-20 KEPS NUT	14**
20	A6761	1/4-20 x 1/2 CARRIAGE BOLT	14**
21	7282-000	1/4-20 NYLOCK NUT	2

REF.	PART NO.	DESCRIPTION	QTY.
24	A6253	DOOR ARM BUSHING	1
25	7127-000	5/16-18 x 1" HEX BOLT	3
26	A6722	IDLER SPROCKET	1
27	A6763	5/16-18 x 4-1/2 HEX BOLT	1
28	A7602	5/16-18 KEPS NUT	4
29	7800-000	1/4" FLAT WASHER	2
30	A7005	POSI-LOCK STOP ASSEMBLY	1
30A	A7924	POSI-LOCK SPACER	1
*31	A6487	25" STRAIGHT ARM	1
32	A6305	17" CURVED DOOR ARM (PACKED WITH HEAD)	1
*33	A7566	DOOR BRACKET, JAMB (RIVETED)	1
35	B6195	DOOR BRACKET	1
36	A7953	CHAIN 134.5"	1
	A7954	CHAIN 121.5"	1
36A	A6758	CHAIN 75.5"	1
37	A7955	CHAIN 98.5"	1
	A7956	CHAIN 86.5"	1
37A	A6791	CHAIN 54.5"	1

Note: Asterisk (*) denotes Jamb Channel (RR) Parts
 **Depends on the channel type for quantity used.

SAFETY PRECAUTIONS

While installing an operator, observe the following safety precautions. They are for your protection and to help make installation easier.

- Door Preparation: Before installing your garage door operator, disable the lock so that the door cannot be locked by accident. Also, remove the rope used for closing the door manually. Failure to do so may be hazardous.
- Hanger straps **must** be secured to ceiling joists or to a header-plate (such as a 2" x 6") which also must be attached to ceiling joists.
- All permanent wiring should be installed in accordance with local electrical codes.
- Do not permit children to play in the door area.
- For operators installed on fiberglass or metal doors, a reinforcement kit should be used. This kit is available from your local dealer. It should be in place before you begin to install your operator.
- The torque sensing (door pressure) mechanism must be in working order at all times. This is to insure that the garage door will reverse its direction if an obstruction is encountered during downward travel. The system should be checked periodically.

SPECIFICATIONS

Door Size and Type: The Model 700-S will open **sectional** and **one-piece track type** doors up to 7 ft. high. Channel assemblies for 8 ft. high doors are also available.

The Model 700-J is for use on **one-piece Jamb Hardware** (no track) type doors up to 8 ft. high.

Required Head Room: 1½" above maximum high-rise point of door.

Travel Time Per Second: Approximately 8" for sectional doors and 5" for one-piece doors.

Control: Can be controlled by a wall button, a radio transmitter, or a key switch.

Motor: 1/3 HPR Split Capacitor, 1000 RPM
1/2 HPR Split Capacitor, 1000 RPM
Split Capacitor, 625 RPM

Power: 120 VAC 60 Hz
240 VAC 50 Hz

FUNCTIONS

- Reverses automatically when an obstacle is encountered during downward travel.
- Light flashes when door is closing (120 version only).
- Stops automatically when an obstacle is encountered during upward travel.
- Automatically returns to full-open position if obstacle/down limit switching system fails.
- Light stays on 5 minutes after each use.
- Door can be "parked" at any point in travel.
- Internal thermal overload protection—motor resets itself.
- Digital remote radio control can be coded by homeowner.

PRE-INSTALLATION

Before starting assembly and installation, review these instructions thoroughly, and identify all requirements and components.

Door Hardware and Lubrication

Door hardware must be well-lubricated with a light coat of oil and operate freely if the operator is to work properly. Lubricate door bearings, rollers, hinges and any other moveable parts. Tighten all hardware. Check door to insure that it is in proper balance and operates smoothly. If door springs are weak or damaged, they should be adjusted or replaced by a qualified serviceman.

Required Tools

The hand tools required to install an operator include a drill and 1/4" bit, hammer, screwdriver, 1/2" and 7/16" socket wrenches, tape measure, level, pliers, and an 8' step-ladder.

CAUTION:

Do not plug in the operator until instructed in Step 9.

Preparation

When you unpack your operator, check to insure that it has not been damaged. Make sure all parts have been received before beginning the installation.

NOTICE:

Lightweight doors of light gauge metal, fiberglass, or wood must be reinforced prior to installation of an operator. Moore-O-Matic is not responsible or liable for damages or injury resulting from improper installation. Consult the door manufacturer for specific reinforcement requirements.

USE MODEL 700-S FOR THESE DOOR TYPES

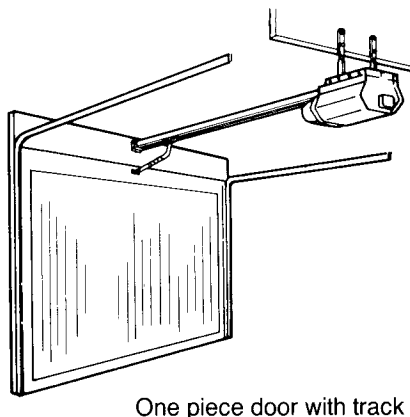
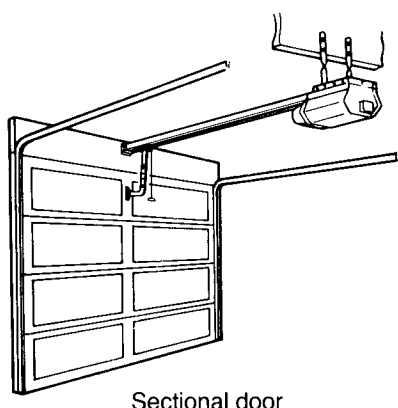

USE MODEL 700-J FOR THIS TYPE DOOR

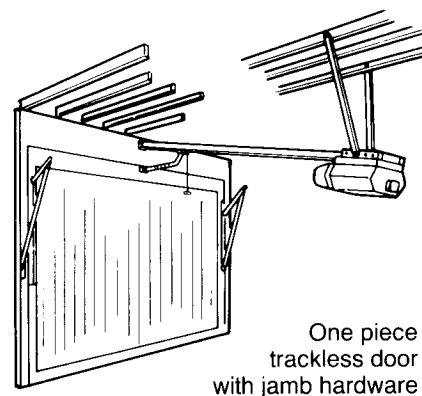

COMPONENT PARTS REQUIRED FOR INSTALLATION

The parts shown on this page are listed in the order used during assembly.

NOTE:
The hardware packaged with this operator is required for several models. Depending on your application, there may be excess hardware.

Trolley Bottom Assembly
See Figure 1, Step 1, Page 5.

Light Lens
See Figure 28, Page 12.

Header Bracket Assembly
See Figure 10, Steps 15 through 18, Page 7.

Hanger Straps (2)
Figure 12, Step 21, Page 7.
(Optional with some models)

Head Channel Hardware
See Figure 2, Step 2, Page 5.

Wall Station Assembly
See Figure 13, Steps 27 through 32, Page 8.

Curved and Straight Door Arms with Mounting Bolts
Keps Nuts (2)
Hex Bolts (2)

Sectional Door: Figures 16, 17, and 18, Page 9, Steps 34 through 37.
Carriage Bolts and Hex Nuts (2)

Sectional Door-Arm Bracket and Mounting Screws.
Figure 16, Page 9, Steps 34 and 35.

Curved and Straight Door Arms with Mounting Bolts
Keps Nuts (2)
Hex Bolts (2)

Trackless Door: Figures 25 and 26, Steps 9 through 11 (page 11).

One-Piece Door-Arm Bracket Assembly
Figures 24 and 25, Step 8 (page 11).
Lag Screws (2)

Step 1: Remove trolley latch assembly from shipping position and slide over the channel, flanges in the proper orientation, as shown in Figure 1.

Note: Arrow to be pointed towards door end of channel.

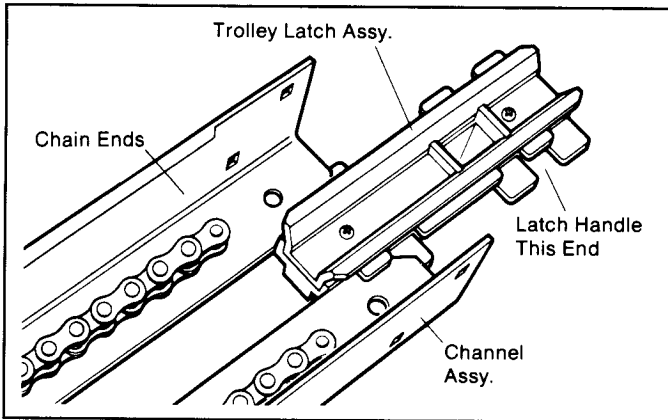

Figure 1. Trolley Latch Installation

Step 2: Place the operator head on the garage floor and secure the channel assembly to the head by four 1/4-20 x 1/2 sems bolts. Do not tighten at this point. (See Figure 2.)

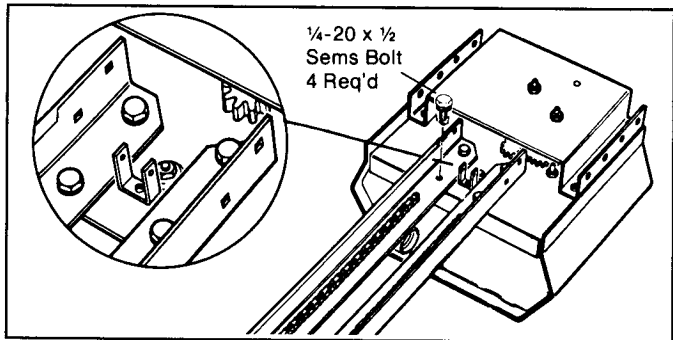

Figure 2. Head Channel Assembly.

Step 3: Locate two each chain master links. Connect the two chain ends of the operator head to the two chain ends of the channel assembly. Make sure there are no kinks and the chain is properly oriented. After connecting the chain ends, remove the ties holding the operator head chain. (See Figure 3.)

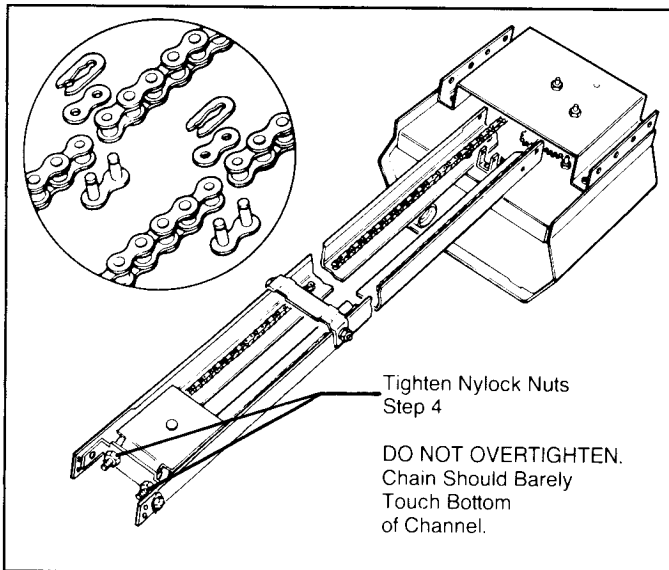

Figure 3. Chain Adjustment.

Step 4: At the channel end turn U bolt nuts to tighten chain. Adjust nuts evenly until chain is taut. See Figure 3. (Do not over-tighten.)

Step 5: Install a 40-watt bulb, appliance type recommended. See Figure 4.

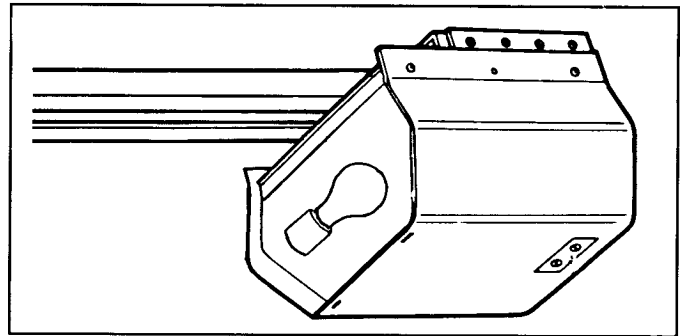

Figure 4. Installing light bulb.

Setting Radio Receiver and Transmitter Codes

Note:

Radios are all factory set to one code. For your own private frequency, code your own set as follows.

A digital coding switch is recessed in the back of the receiver. The transmitter is a hand-held, portable unit that contains an 8-key coding switch that is identical to the switch in the receiver. Individual codes are created by setting the eight coding keys to various ON and OFF positions.

Receiver/Transmitter Coding Switch Locations

Step 6: Locate the coding switch recessed in back of the receiver. Before removing receiver, note terminals used. (See Figure 5.)

Step 7: The transmitter's coding switch is located beneath the small access cover on the back of the transmitter case. To open, insert thumbnail or small screwdriver into either of the small slots at the edge of the case and pry upward. The digital coding switch inside has eight keys numbered 1 through 8. (See Figure 6.)

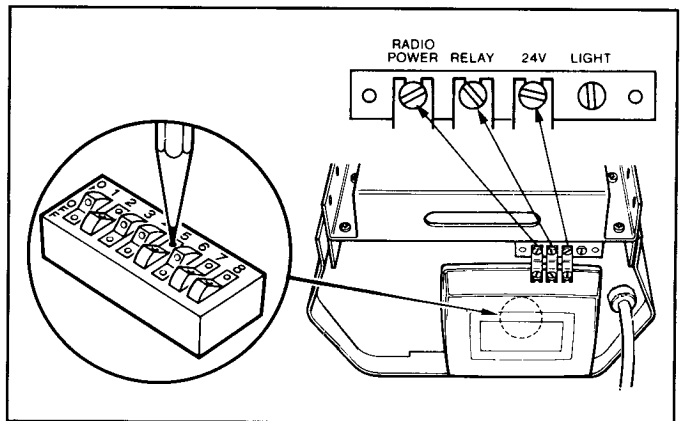

Figure 5. Receiver Coding Switch.

Step 8: Select a code. Then use a pencil or ballpoint pen to set the code keys on the transmitter and the receiver (see Figure 5 and 6).

Note:
In order for the digital controls to function, the codes set in both the transmitter and the receiver must be identical.

From left to right, the example code in Figure 5 shows that keys numbered 1, 3, 4 and 6 are OFF.

After the new code has been set, and before assembling the transmitter and receiver, check out both switch settings again. Be certain that the codes are identical.

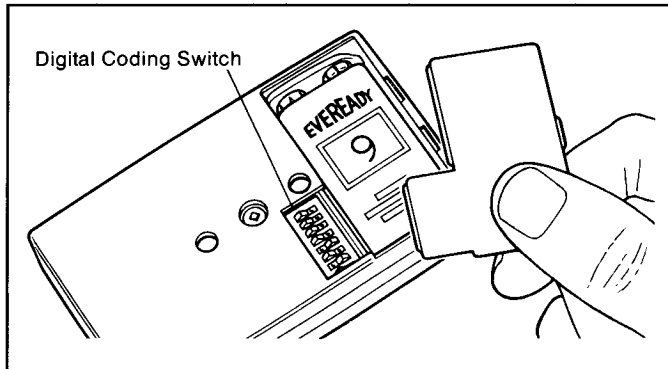

Figure 6. Transmitter Coding Switch.

Note:

While 256 separate codes are available, the keys should not be set to all ON, all OFF, or to alternating OFF-ON positions. These are valid codes, but their use is not recommended because they are too easy to duplicate.

Testing of Opener Prior to Installation

Step 9: Plug operator cord into a grounded receptacle. The operator light should turn on. This is a normal function and the light will turn off in approximately five minutes. If the light does not turn on, check power source.

Testing Opener

Step 10: Check terminal screws (Figure 5) to verify that connections are tight.

Step 11: This step confirms that power is being supplied to the operator and that the motor and chain drive mechanism function properly. Note that since this is a low voltage circuit, this test does not constitute a shock hazard.

Using a screwdriver or needle nose pliers, momentarily touch the center two terminals ("Relay" and "24V") simultaneously. When the connection is made, the motor should start and the chain should move. After breaking the connection, the motor will stop when the trolley reaches its end of travel near the operator head.

Flashing Alert Light (120 version only)

This operator features the "Flashing Alert" action. As soon as the door is commanded to close, the light on the operator starts flashing. Two seconds later, the door starts to move down and the light continues to flash until the door is completely closed.

Step 12: Repeat operations test using radio control.

Step 13: After completing the check, make sure that the trolley assembly is positioned at the door end of the channel.

Note:

Do not worry about the amount of travel at this time. Adjustment will be made after installation is complete.

Step 14: Disconnect operator cord from AC power.

INSTALLATION

Identify your type of door in Figure 7 and proceed as instructed.

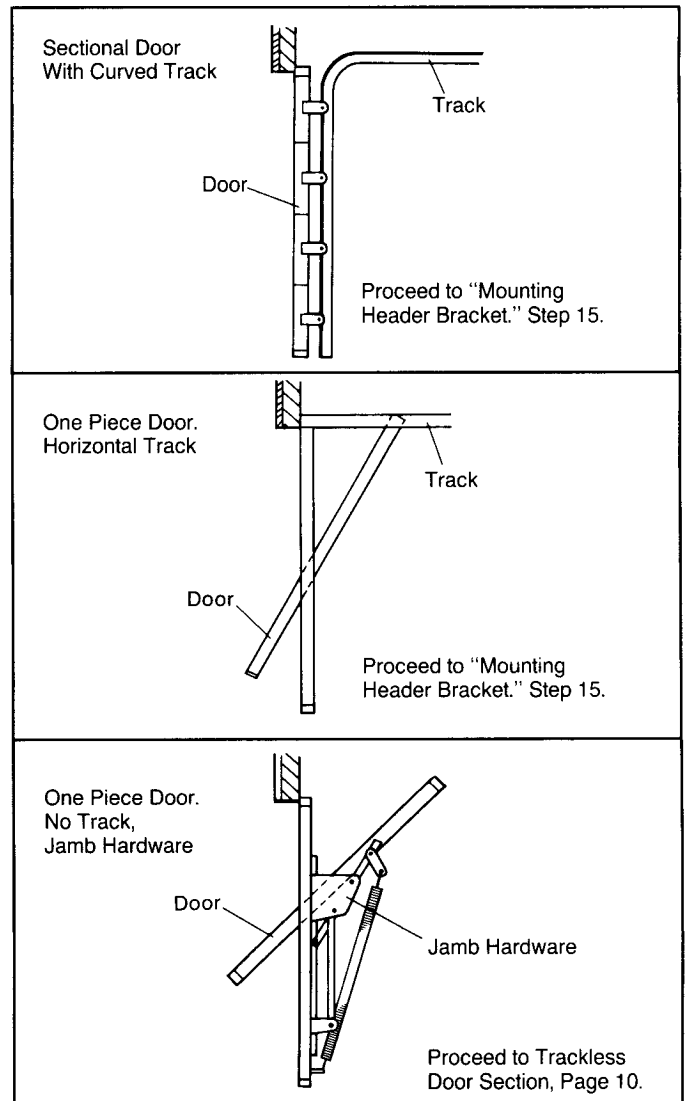

Figure 7. Types of Doors.

SECTIONAL AND ONE PIECE TRACK DOORS

Mounting Header Bracket

The header bracket and two lag screws are required to complete the following installation sequence.

Step 15: Determine center line of door, (Figure 8). Mark center line on header and top of door.

Step 16: Determine high-rise point of door (highest point door reaches when opening). See Figure 9. Place straight edge or level at the top of the center of the door at its highest point of travel. Make sure straight edge is level and mark the door header where it touches. This is your high-rise point.

Step 17: If high-rise point is above door header, install 2"x6" mounting board at this point. (See Figure 10.)

Step 18: Use lag screws to mount bottom of header bracket one inch (1") above high-rise point on center line of header. (Figure 10.)

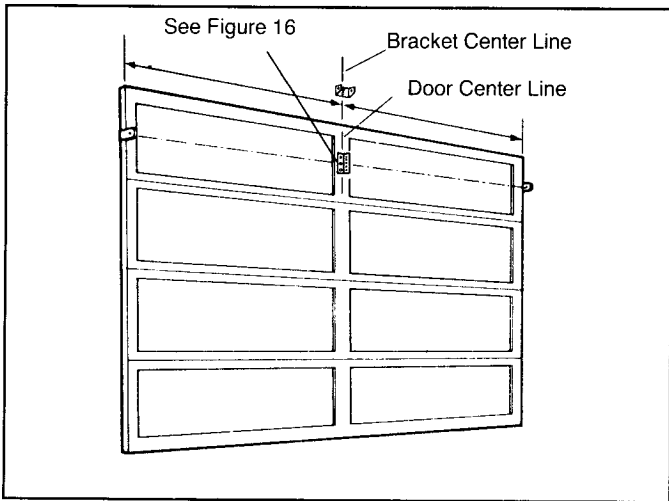

Figure 8. Center of Door.

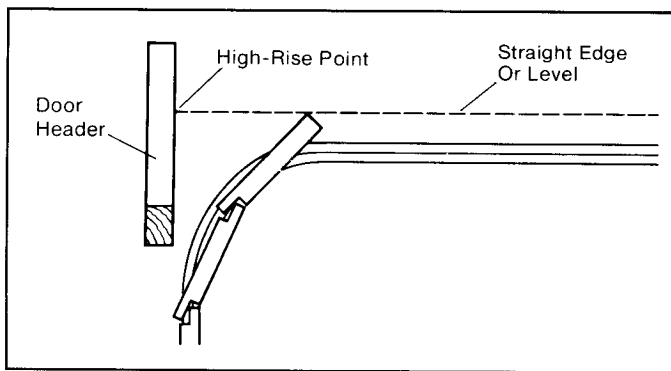

Figure 9: Determine High-Rise Point (Sectional Door)

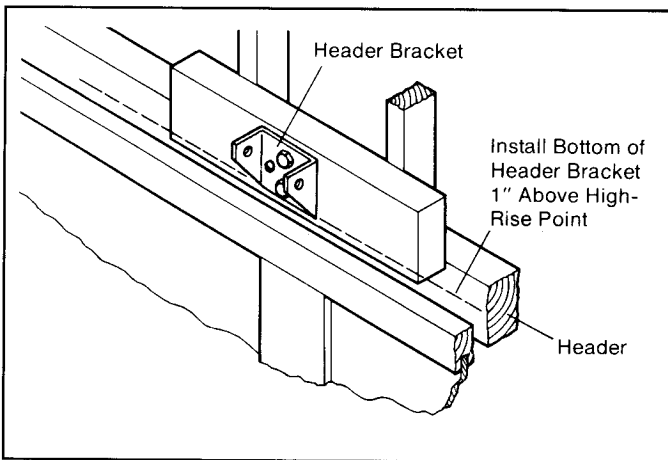

Figure 10: Header Bracket.

Mounting Channel To Header Bracket

A 5/16x4-1/2 bolt and keps nut are required to complete this part of the installation.

Step 19: Place the assembled operator on the floor with the exposed end of channel facing the door. Put the operator head on the empty carton (See Figure 11). Next, raise the end of the channel and insert it in the header bracket (Figure 10). Secure the channel in the bracket using the bolt and keps nut supplied. Note: Do not tighten the keps nut on bolt until the power head has been mounted.

Note:
When the door is equipped with a torsion spring, the spring extends inward above the door to a distance which creates an angle that makes it impossible to rest the operator head on the floor as shown in Figure 11. For such installation, place the power head on a ladder so that the channel will clear the torsion spring and reach the header bracket.

Step 20: Raise the head end of the operator and rest it on a ladder about 8' above the floor so that the operator will not obstruct the door when it is opened. See Figure 11. Next, raise garage door to the fully open position.

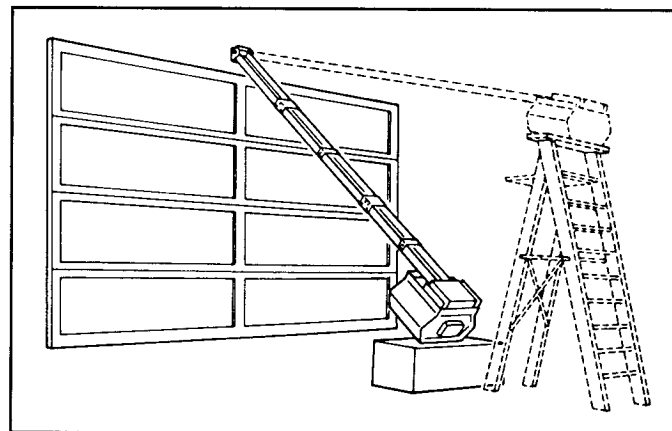

Figure 11. Mounting Operator On Header Bracket.

Mounting Power Unit End of Opener

Hanger straps, lag screws, 5/16"x1/2" hex bolts, and keps nuts are required to install the power head.

Step 21: Bolt hanger straps to power head using most convenient holes. See Figure 12.

Step 22: Center the power head and channel in line with the header bracket. To accomplish this, align channel with pencil mark at the top-center of the door as shown in Figures 8 and 12.

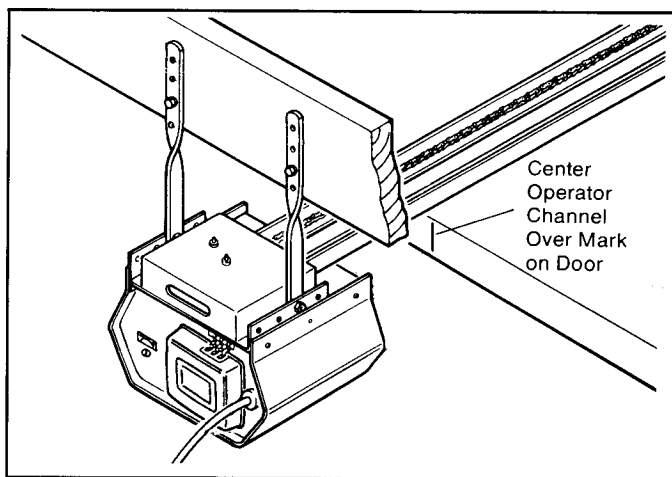

Figure 12. Centering Operator (Door Fully Open).

Step 23: Raise channel two inches above top edge of door. Use the lag screws provided to attach the hanger straps to ceiling joist or header, as shown in Figure 12. Note that the channel must clear the door.

Step 24: Open and close the door manually to insure that it clears the channel assembly. Then, tighten the bolt on the header bracket.

Note:
Installation requirements may vary with garage construction. Additional material may be required for finished ceiling (dry wall or plaster). In such cases, be sure that the hanger straps are secured to ceiling joists, or to a header-plate (See Figure 12) which, in turn, must be attached through the finished ceiling to the supporting joists.

Connection To Power Source

Step 25: The operator power head should be connected to a grounded receptacle located on the ceiling or near the operator's head. If no receptacle is available close by, one should be installed.

Step 26: Plug operator power cord into receptacle.

Caution:
Some local codes require the use of metal conduit to bring power to the operator. When such requirements exist, the installer must then perform steps "A" through "E" as follows:

Step A: Disconnect power cord and remove bottom cover from power head.

Step B: Cut the power cord about three inches from the back of the power unit. Next, pull the three colored power wires into the power head enclosure—one at a time.

Step C: Then, using pliers, remove the insulated cable section from the retaining ring and push ring out of the case—from the inside out.

Step D: Pull the three colored power wires through conduit and use wire nuts to connect them to the matching wires inside power head.

Step E: Lock conduit into operator head and connect wires and conduit to junction box at power source. At this point, power should be available at the operator head.

Note:
All permanent wiring should be installed in accordance to local electrical codes.

Step 29: Using the two small screws provided, mount the wall switch at the selected position.

Step 30: Run wires up wall and across ceiling to back of power head. When staples are used to mount wires, they must straddle both wires so that no electrical shorts occur.

Step 31: Cut off excess wire at the power head, strip wire ends and attach one wire to terminal marked "RELAY". Attach the other wire to terminal marked "24V". (See Figure 14.)

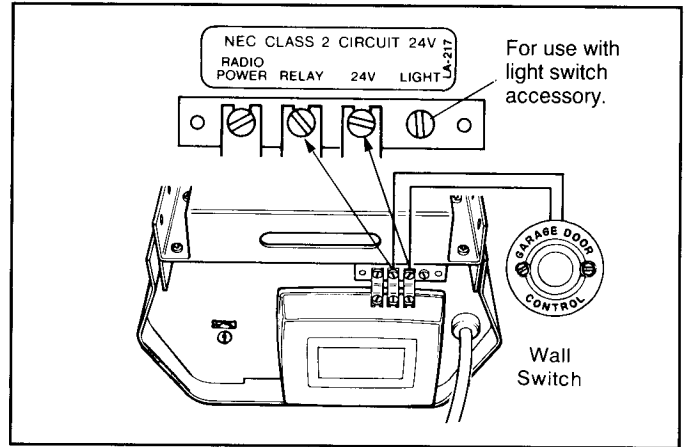

Figure 14. Wall Station Connections.

Step 32: Test the wall switch function by pressing the button. At this point, the motor should engage and operate the chain drive mechanism.

Note:
The light will turn on and remain on for five minutes. This time interval will occur each time the pushbutton or transmitter is activated. Note that on 120V operators, while running in the down direction only, the light will flash on and off. Note that the light on the operator will remain on for five more minutes.

Note:
The label shown in Figure 15 must be mounted in a visible place near the wall switch.

Connecting Wall Button Station

A length of two-conductor wire and staples are the only materials required to connect a wall switch to the operator. Perform the following steps to complete this part of the installation.

Step 27: Select a convenient mounting location for the wall switch near an access door. It is recommended that it be mounted no lower than 5' so as to be out of reach of small children. See Figure 15.

Step 28: Attach one wire to each of the two terminal screws on the back of the wall switch (See Figure 13).

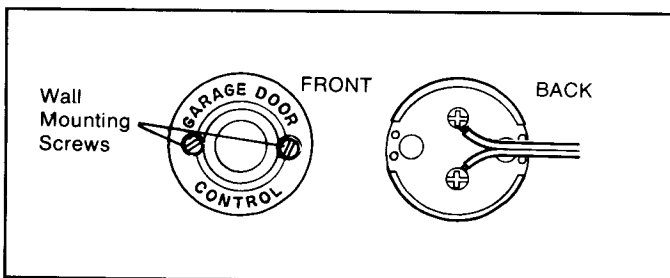

Figure 13. Wall Switch Wiring

CAUTION
 OPERATE DOOR ONLY WHEN FULLY VISIBLE, PROPERLY ADJUSTED AND FREE OF OBSTRUCTIONS.
DO NOT PERMIT CHILDREN TO PLAY IN AREA OF DOOR.
INSTALL PUSH BUTTON OUT OF REACH OF SMALL CHILDREN--RECOMMEND NO LOWER THAN FIVE FT.
 TO DETACH OPERATOR FROM DOOR, PULL DOWN ON RED SAFETY HANDLE.
SAFETY REVERSE SHOULD BE CHECKED AT LEAST MONTHLY. SEE INSTRUCTION MANUAL FOR CHECKING SAFETY REVERSE.
 (THIS LABEL IS TO BE MOUNTED NEAR PUSH BUTTON.) LA-011

Figure 15. Wall Switch Label

Attaching Door Bracket And Door Arm

Step 33: For sectional doors, proceed to Step 34. For one-piece trackless doors, go to page 10.

Note:
For operators installed on fiberglass or metal doors, a reinforcement kit must be used. This kit is available from your dealer. It must be in place before attempting to install the door bracket.

Step 34: To complete this part of installation, it is necessary to use the door arm (which consists of two 17" sections, one straight and one curved), a door bracket, clevis pin, hitch pin, bolt with bushing, carriage bolts with keps nuts, and a quick-release pull cord.

The right-angled portion of the bracket (which contains the door-arm adjustment holes) should be mounted at the center line of the door with the outward facing angle to the right (see Figure 16). Note that the middle of the mounting bracket should be in line with the top rollers at the sides of the door. To install, use the door bracket as a template and mark position of top and bottom bolt locations on door and drill 1/4" holes. Note that the carriage bolts should be inserted through the bracket from the outside of the door.

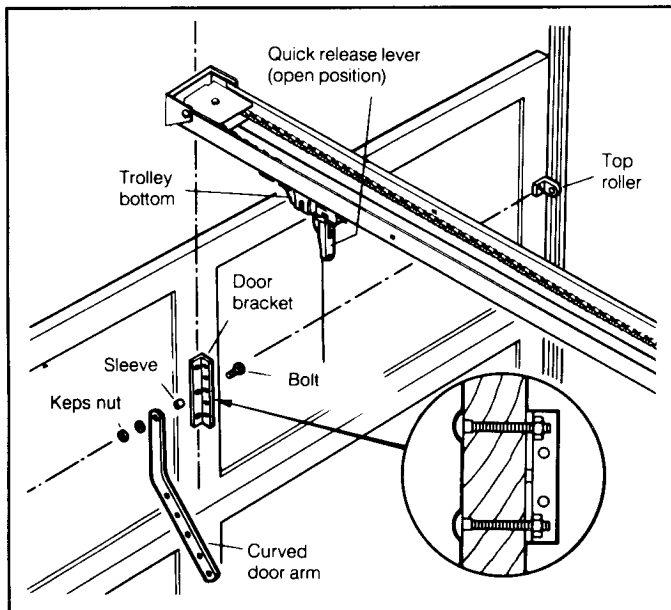

Figure 16. Mounting Bracket and Curved Door-Arm Location

Step 35: Attach the curved door arm to the center hole on the bracket with a keps nut and bolt (see Figure 16).

Step 36: Insert the straight section of the door arm into the quick release trolley bottom and insert the clevis pin through the quick release trolley bottom and door arm and lock in place with the hitch pin (see Figure 17).

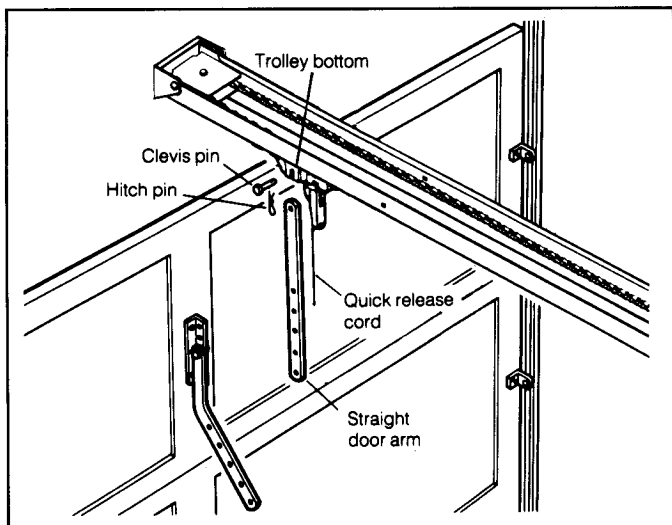

Figure 17. Straight Door Arm Section Attached to Trolley

Step 37: Connect the two free ends of the door-arm assembly by rotating the curved section upward to the straight section so that two holes in each section can be matched. See Figure 18.

Note: If the holes do not match precisely, slide the trolley bottom toward the operator head till a match occurs. At that point, insert a bolt at the top adjoining holes. Next, insert second bolt through lowest set of adjoining holes.

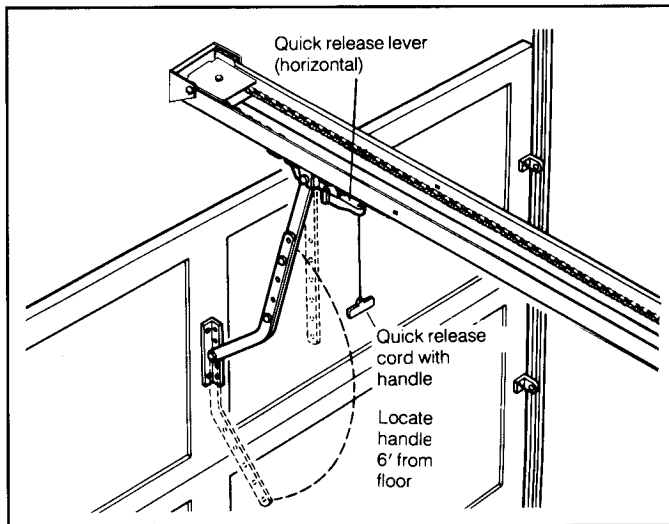

Figure 18. Connecting Door Arm Sections and Quick Release Cord

Step 38: Attach pull cord to quick-release lever on trolley bottom as shown in Figure 18. The red handle should be 6' above the garage floor.

Note:

The quick-release lever (with pull-cord attached) must be in the horizontal position (up) (See Figure 18.). If the quick-release (disconnect) lever is in the vertical position (down) the trolley bottom will not engage the "traveler" that rides the chain drive and the door will not move.

Step 39: Raise the door manually until the quick-release mechanism in the trolley bottom engages the traveler on the chain drive. Note: If it is difficult to raise the door, pull the door arm toward the operator head (away from the door) while lifting the door. When the trolley bottom engages the traveler, it will snap together audibly, lock into position, and cease to move.

Adjusting Door Travel

Up-Down Travel Adjustment

The up and down travel limits are adjusted in the following sequence.

Step 40: Depress the transmitter button and observe the door's direction of travel and where it stops.

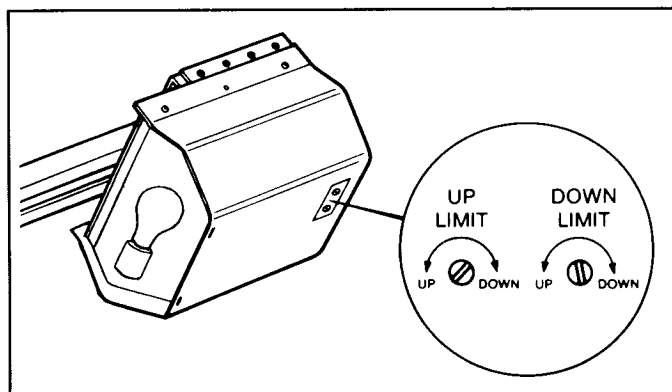

Figure 19. Adjusting Travel Limits.

Step 41: To increase the "down" distance, turn the slotted "Down Limit" screw in the clockwise direction. (See Figure 19). Note that each turn is equal to approximately one inch of door travel. Then estimate the number of turns required.

Step 42: Activate the transmitter again. The door will open to the point where the "Up Limit" switch is set. If more upward travel is

required, estimate the additional distance needed, and adjust the "Up-Limit" screw in the counter-clockwise direction.

Step 43: Activate the transmitter again and the door will travel downward to the newly set "Down Limit".

Step 44: Continue the procedure described in Steps 41, 42 and 43 until the desired fully-closed and fully-open limits are reached.

Note:

As the door approaches the upper and lower limits selected, reduce the number of turns per adjustment.

Step 45: To decrease the upper and/or lower travel limit, activate the transmitter and, while the door is still in motion (up or down) activate the transmitter again. This will stop the door in the "park" position. Then decrease the travel adjustment as desired.

"Parking" the door a distance away from the limit switches (instead of against them) makes the adjustment easier.

Step 46: To provide positive mechanical locking, see Page 12, Steps 14 through 16, "Posi Lock Stop."

Adjusting Door Pressure Sensitivity

The door pressure (torque sensing) mechanism must be in proper adjustment at all times. This is required to insure that the garage door will reverse its direction in the event that an obstruction is encountered during downward travel. Factory setting is at mid-range.

NOTE: Read the following directions thoroughly before setting the door pressure.

Step 1: Activate the transmitter to raise door to the open position.

Step 2: Place a sturdy obstruction of approximately 12 inches in height, in the center of the doorway and in a position where it will obstruct the door's downward travel.

Step 3: Activate the transmitter so that the door will close and contact the obstruction. The door should reverse its direction of travel within 2 seconds after it encounters the obstruction.

NOTE: If the door does not reverse automatically, it indicates that the pressure is too great and should be reduced. If the door reverses during the downward travel the pressure is too sensitive and should be increased.

To Decrease Pressure: Activate the transmitter to stop the door. Then activate the transmitter again so that it will raise the door and clear the obstruction. When the door clears the obstruction, turn the Door Pressure adjustment counter-clockwise in the "DECREASE" direction. See Figure 20.

To Increase Pressure: If, during the process of adjustment, the door pressure becomes too sensitive, slowly turn the adjustment in the "INCREASE" direction (clockwise). See Figure 20.

NOTE: The door pressure should be no greater than is required to cause the door to reverse its direction when it encounters an obstruction while closing.

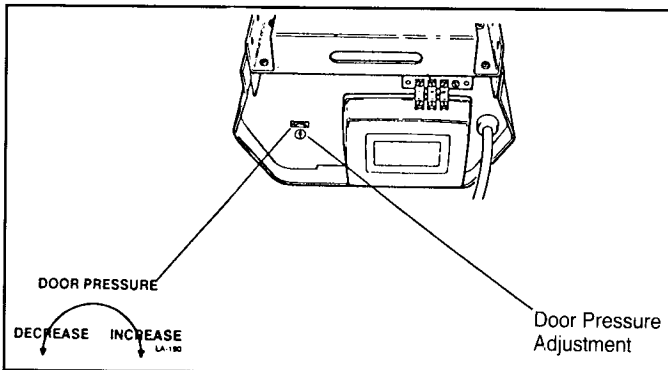

Figure 20. Adjusting Door Pressure.

WARNING:
The door, door hardware and equipment should be checked often, but at least monthly, to insure that door, and operator, are properly functioning.

TRACKLESS DOORS (JAMB)

The requirements for installing a garage door operator on a trackless door are different from the requirements for installing the same type operator on a sectional or one-piece track-mounted door.

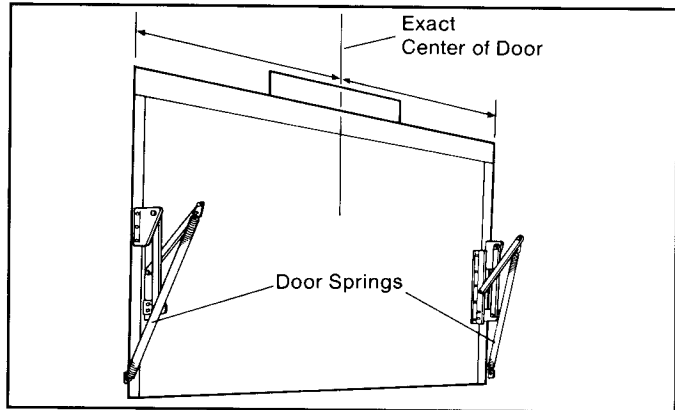

Figure 21. Center of Door.

Trackless doors are one-piece doors which employ jamb-type counterbalance hardware as part of the lifting mechanism. They are sometimes called "California" doors. Typically, the one-piece door and its accompanying hardware appear as shown in Figure 21. Note that there is another type of one-piece, trackless door that operates on a pivot. However, it is not shown in this manual because the installation requirements for pivot-mounted doors are the same as for those equipped with jamb-type hardware.

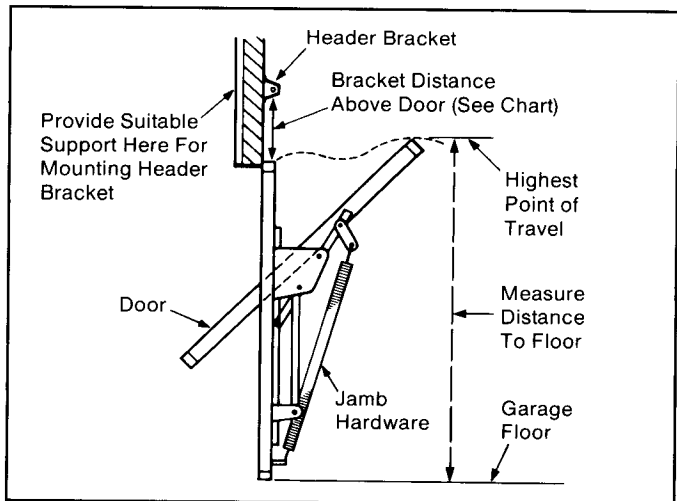

Figure 22. Finding High-Rise Point.

Note:
For optimum operation of trackless doors, the power head end of the operator should be lower than the end of the channel attached to the header bracket above the door. In turn, this requirement makes it necessary to install the header bracket high enough above the door so that the high-rise point of the door clears the channel when the door opens and closes.

Attaching The Header Bracket

Step 1: Establish the exact center of the door and mark that location on the header above the door as shown in Figure 21.

Step 2: Establish the high-rise point of the door. That is its highest point of travel when it opens or closes. See Figure 22 on page 10. To establish this point, open the door and measure the distance between its highest point of travel and the floor. Next, measure the height of the door. The difference is the door rise.

Step 3: Having calculated the door rise, refer to the chart shown in Figure 23. With reference to the high-rise point, the chart shows the distance above the door where the header bracket should be installed.

Step 4: Using the lag screws provided, install header bracket on center line of door at the height shown in Figure 23.

NOTE: These charted header bracket locations cannot be achieved in garages with low ceilings. If this is the situation, mount the header bracket as high as possible, and hang the head end at the lowest acceptable (safe) level.

High-Rise Point Above Door (In Inches)	Location of Header Bracket Above Door (In Inches)
Up to 4	Up to 10
4 to 8	10 to 15
8 to 12*	15 to 20

Figure 23. Locating Header Bracket Above Door.

Mounting Operator To Header Bracket

To complete this series of steps, hanger straps, lag screws, 5/16" x 1/2" hex bolts, and keps nuts are required.

Step 5: Bolt hanger straps to power head. (See Figure 12, Page 7). Note: Four hole end is at top and bottom end is inside head flange.

Step 6: Raise power head end of operator until high-rise point of door clears channel assembly by at least one inch, or until the power head is level with the top edge of the door when it is in the open position. (See Figure 24). Temporarily maintain that position (on a ladder for example) until the strap hangers on the operator head are permanently mounted.

Step 7: For mounting power head, electrical power connections, wall station, and radio controls, refer to Step 21 (Page 7) through Step 32 (Page 8).

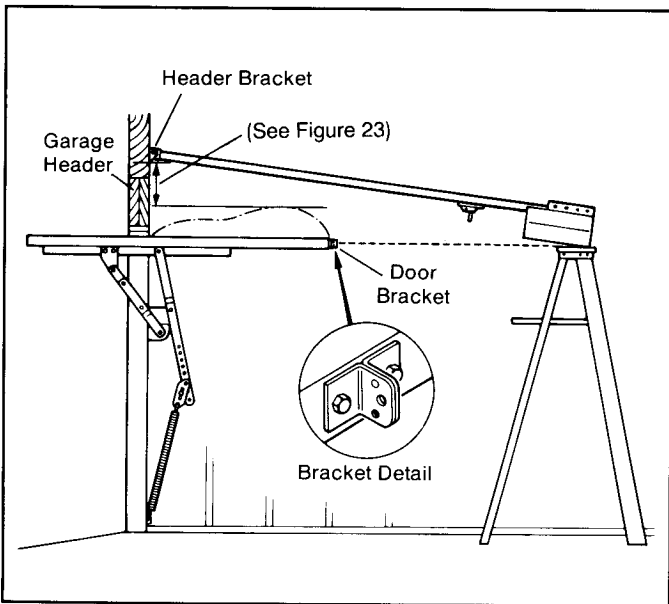

Figure 24. Positioning Power Head.

Mounting The Door Bracket And Door Arm

The door bracket and door arm assemblies for trackless doors are shown in Figures 24, 25, and 26.

Step 8: Locate center line of door. Refer to Figure 8, Page 7. Next, install door bracket on center line as close as possible to the top edge of the door. Use carriage bolts and keps nuts (See Figure 25).

Step 9: Slide the door bushing onto the 5/16" x 1" bolt provided. Next, hold the straight door arm up to the door bracket already mounted and align the proper holes up. See Figure 25. With the other hand, insert the bolt into the aligned holes and secure with the 5/16"-18 keps nut. Make sure the door bushing seats squarely inside the door arm hole. At this point, tighten the keps nut on the header bolt.

Step 10: Attach the curved section of the door arm to the trolley bottom as shown in Figure 26. To attach, remove the hitch-pin clip from the clevis pin and remove the clevis pin from the trolley bottom. Next, insert door arm section into trolley bottom and place clevis pin through the trolley bottom and door arm and lock in place with hitch-pin.

Step 11: Connect the two free ends of the door arms by rotating the straight section upward to the rear-vertical (toward the curved door-arm section) so that two holes in each section can be matched. See Figure 26. Connect the two parts of the door arm using the bolts and keps nuts supplied.

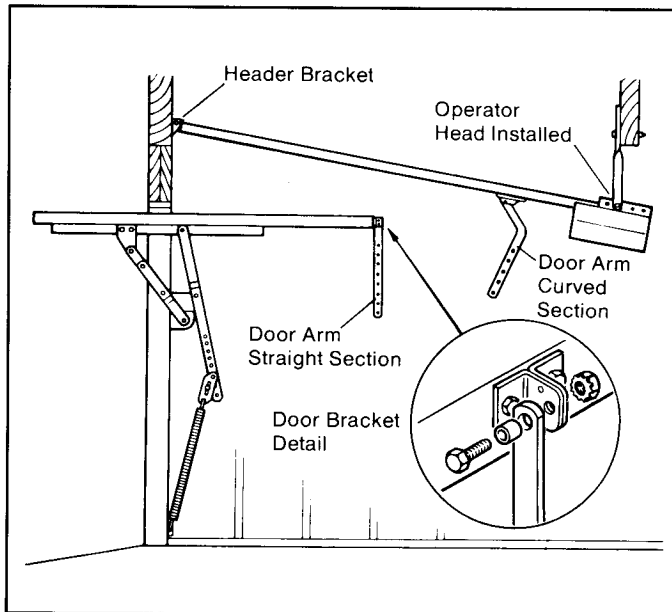

Figure 25. Door Bracket and Door Arm Installation.

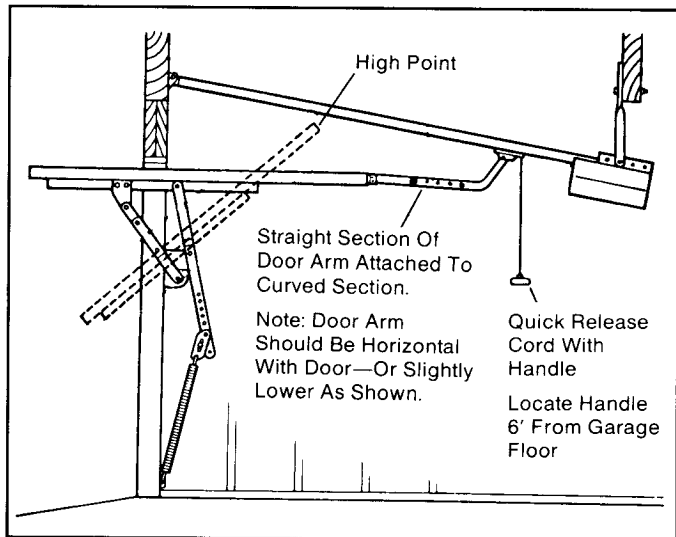

Figure 26. Connecting Door Arm Sections.

Note: If holes do not match precisely, slide the trolley bottom toward the operator head until a match occurs. At that point, insert a bolt through top adjoining holes, next, insert second bolt through lowest set of adjoining holes.

Step 12: Attach pull cord to quick-release lever on trolley bottom as shown in Figure 26 on page 11.

Setting Travel Limits

Step 13: Refer to Steps 40 through 45 (Pages 9 and 10).

THE POSI-LOCK STOP

Step 14: After the limits have been set and all other systems are working, install the Posi-Lock STOP and the Posi-Lock SPACER (item Q). The Posi-Lock mechanism is preassembled into the chain and trolley unit at the factory but to make it functional a stop or clamp must be fixed to the channel. When force is exerted to open a closed door, the trolley will apply a side pressure to the Posi-Lock PLATE (item P) causing it to engage the STOP (item S) which will prevent any further movement of the trolley and drive system.

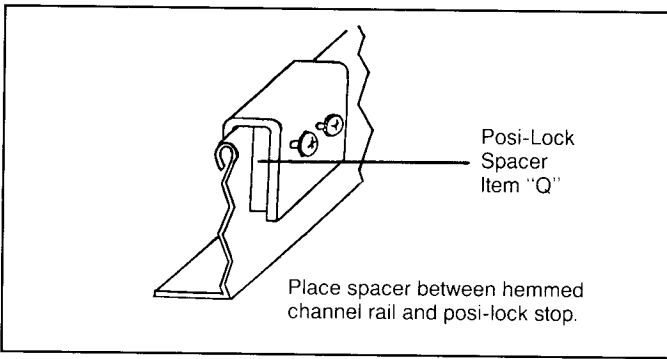

Figure 27. Placement of Posi-Lock Spacer.

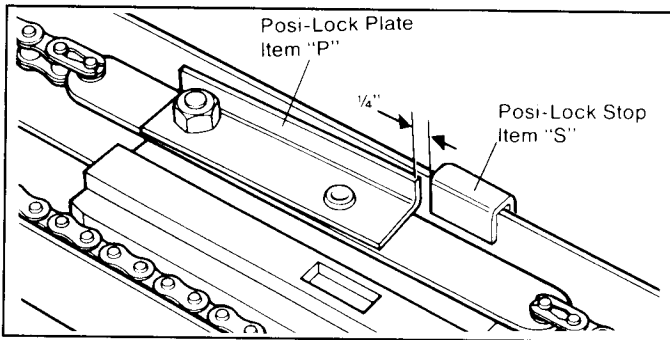

Figure 28. Adjusting Posi-Lock Stop.

Step 15: Run the door down to its normally fully-closed position under power.

Step 16: Clamp the Posi-Lock STOP to the channel rail at a point exactly 1/4" from the Posi-Lock PLATE, screws to the outside. Figure 28.

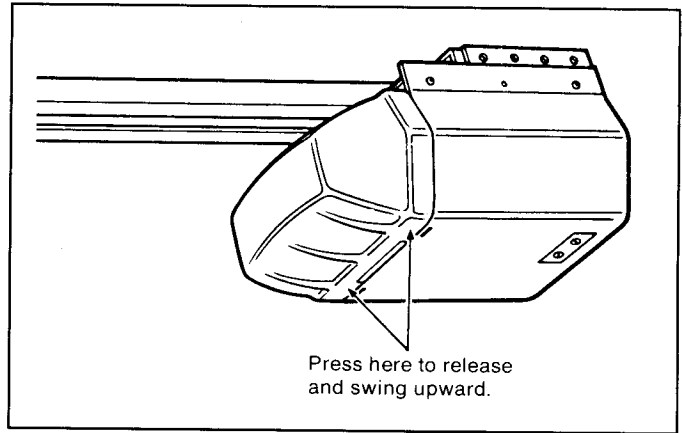

Figure 29. Inserting light lens.

ATTACHING LIGHT LENS

Insert the top retainer tabs into the slots in the chassis. Swing the light lens down and snap it into the slots in the wrap cover. See Figure 29. For replacing the light bulb, press the bottom of the light lens to release the retainer tabs and swing upwards to detach the top retainer tabs.

TROUBLE SHOOTING GUIDE

SYMPTOM	POSSIBLE CAUSE	REMEDY
Starts without apparent cause (phantom operation)	Unwanted radio signal from unknown source Intermittent short in wall switch wiring Receiver decoding chip bad	Change digital code Remove cause of short Replace or repair receiver
Works from wall switch but not from radio control	Dead battery in transmitter Faulty radio receiver or transmitter	Replace battery Repair or replace radio set
Works from radio control but not from wall switch	Defective or "open" wall switch or wall switch wiring	Locate "open" and repair
Does not run, no sound when button is pushed	Faulty control board Loose connector or broken wire Dead 115V power source (garage wiring)	Replace board Repair wire Replace fuse or reset circuit breaker
Will not shut off at limit(s)	"Open" in limit switch circuit— loose connection or broken wire Channel assembly out of phase with head	Tighten connector or repair break Remove head & synchronize with channel assembly
Won't reverse on obstruction	Defective circuit	Refer to dealer
Lights won't come on	Faulty control board Bad splice connection	Replace board Re-splice
Lights won't go off	Faulty control board	Replace board
Operator runs sluggish even when disconnected from door	Faulty motor capacitor	Replace motor capacitor

HOW TO OBTAIN REPLACEMENT PARTS AND SERVICE

Contact the retail store, dealer, or installer from whom the operator was purchased. However, if you are unable to obtain parts or service required, you may write to:

Moore-O-Matic, Inc.

Western Repair Center
2066 Wineridge Place
Escondido, CA 92025-1451

Central Repair Center
419 Oak Street
Waupaca, WI 54981

NOTE

Replacement parts will be made available at current prices. If requested, prices will be quoted in advance. When parts are ordered by mail, you will be responsible for shipping charges.

If you require parts or assistance, be prepared to provide the following:

1. Model, serial number and all of the other data shown on the data plate.
2. The date and the establishment from which you purchased your operator.
3. Brief description of your problem or requirement.
4. Part numbers are shown in the parts list that accompany this manual.

Accessories Available from the factory or your retail store



Garage Door Release

For garage with no service door.
Releases operator from outside.
(To be used on doors up to 1" thick.)

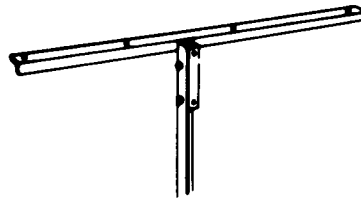

A3157 FDR-K

Door Reinforcement Kit

For stiffening top panel of fiberglass, hardboard or light metal door. Do not use an operator on a lightweight door without reinforcement.

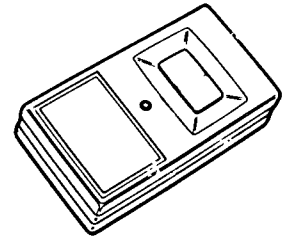

DT

Replacement for lost or broken transmitters or convenient extras for home or second car.

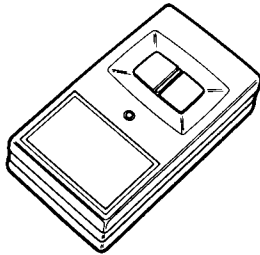

**DT-2A
2-Button Transmitter**

Operates 2 operators independently.
Digitally match two personal codes with two receivers.

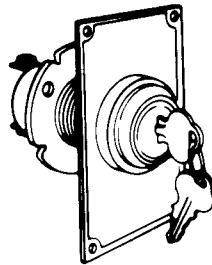

Key Lock Switch

For a wired control station outside a garage. Secure from anyone without a key.

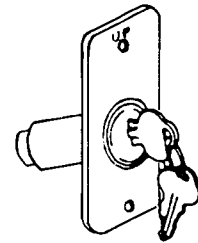

Garage Door Release

For garage with no service door.
Releases operator from outside.
(To be used on doors up to 2" thick.)

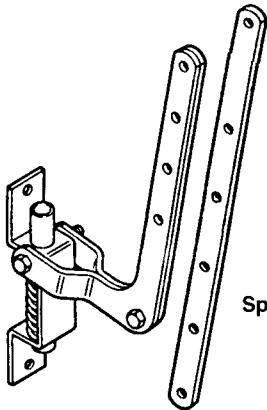

A7488

**Spring Loaded Door
Arm Assembly**
Optional for
sectional doors

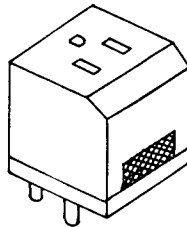

A7847

Surge Protector

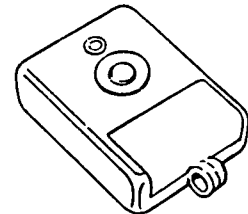

DNT026/B

Single or Double Packs
Matchbox size transmitter fits on a
key chain

REPLACEMENT PARTS LIST

MODEL 700/727/750/757 S & J AND 700-240 EXPLODED VIEW OPERATOR HEAD ASSEMBLY

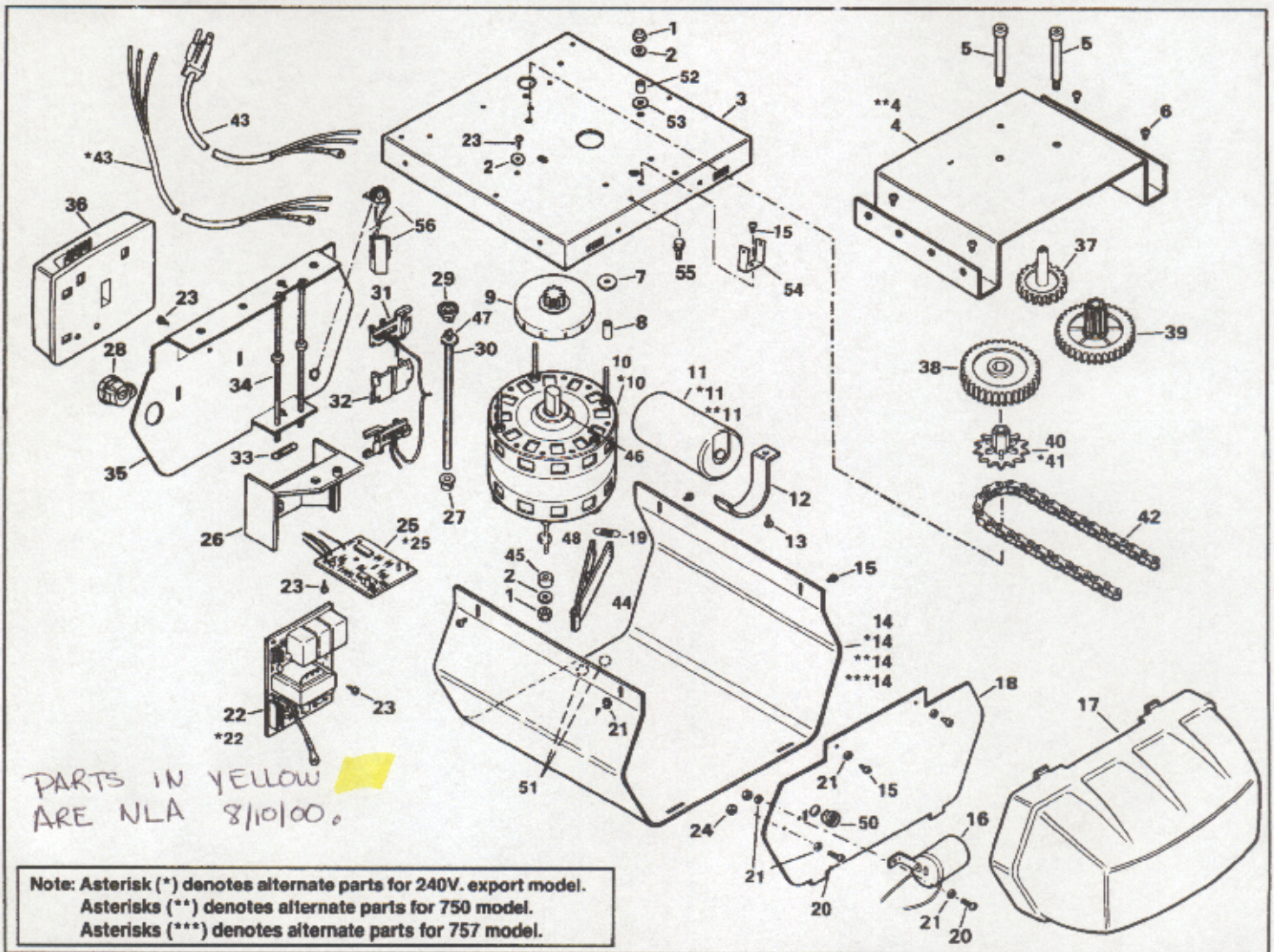

REF.	PART NO.	DESCRIPTION	QTY.	REF.	PART NO.	DESCRIPTION	QTY.	REF.	PART NO.	DESCRIPTION	QTY.
1	A7826	#10-32 NYLOCK HEX NUT LP	4	17	8311-000	LIGHT LENS	1	37	A6720	LIMIT GEAR	1
2	7849-000	#10 FLAT WASHER	5	18	A6716	FRONT PLATE	1	38	A6721	38 TOOTH GEAR	1
3	A6748	CHASSIS	1	19	A7104	SPRING	2	39	A6723	36/9 TOOTH GEAR	1
4	A6710	COVER, GEAR	1	20	7564-000	#6-32x7/16 PN HD PH SCREW	2	40	A6728	9 T. SPROCKET (JAMB)	1
**4	A7851	COVER, GEAR 750 BLACK	1	21	7832-000	#6 INT TOOTH LOCK WASHER	4	*41	A6724	13 T. SPROCKET (SECT. 240V.)	1
5	A6739	5/16x1-3/4 STRIPPER BOLT	2	22	A7608	CONTROLLER, L411R BOARD	1	42	A6753	15.5 IN CHAIN	1
6	A7795	#8-32x3/8 PN HD PH TYPE D SCREW	4	**22	A7639	CONTROLLER, L411-R2 (240 V.)	1	43	B5731	POWER CORD ASSY. 56"	1
7	A3728	.203x.750x.062 FLAT WASHER	3	23	A6786	#8x3/8 PN HD SCREW	4	*43	A6973	POWER CORD ASSY. (240V.) 48"	1
8	A7266	SPACER .75 LG	3	24	7202-000	#6-32 HEX NUT	2	44	A7092	BRAKE ARM ASSY.	2
9	A6725	9-TOOTH PINION GEAR	1	25	A7767	TORQUE SENSOR ASSY. ADJ.	1	45	A6935	NYLON SPACER .50 OD x .19 ID	1
10	A6732	1000 RPM MOTOR	1	*25	A7649	TORQUE SENSOR ASSY. (240 V.)	1	46	A7084	NYLON WASHER	AR
**10	A7177	625 RPM MOTOR 240V.	1	26	A6726	RETAINER	1	47	A7095	RING, EXT. PUSH-ON .374 ID	1
11	A6993	43-53 MFD CAPACITOR	1	27	B5588	.22 ID C.E. KEYED BEARING	1	48	7205-000	NUT, #10-32 HEX	1
**11	A7433	15 MFD MEPCO 370 V.	1	28	A5409	.875 OD STRAIN RELIEF BUSHING	1	50	B6161	BUSHING .375 ID, SNAP	1
**11	8026-000	53-64 MFD CAPACITOR	1	29	B5587	.22 ID KEYED BEARING	1	51	A6741	GROMMET .187 ID x .312 OD	2
12	A6737	CAPACITOR BRACKET	1	30	B5663	LIMIT SHAFT	1	52	A7265	SPACER 25 LG	3
13	A7023	#10x3/8 PN HD PHLP SCREW	1	31	A7765	LIMIT SWITCH ASSEMBLY	1	53	A7268	GROMMET .312 ID x .625 OD	3
14	A6630	WRAP COVER (TAN) 727 Ser.	1	32	A7226	LIMIT SWITCH TRAVELER	1	54	A6735	BRACKET, CH RETAINER	1
*14	A6631	WRAP COVER (GRAY) 700 Ser.	1	33	B6078	SPRING	1	55	A7604	1/4-20 x 1/2 SEMS BOLT	4
**14	A7854	WRAP COVER (BLUE) 750 Ser.	1	34	B6526	LIMIT ADJUST SCREW	2	56	A7760	POT ASSEMBLY	1
**14	A7917	WRAP COVER (RUST) 757 Ser.	1	35	A6749	BACK PLATE ASSY.	1				
15	A6937	#6x1/4 PN HD PHLP SCREW	10	36	DNR009	REC DRNR (Domestic Only)	1				
16	A4906	LAMP HOLDER	1								

REPLACEMENT PARTS LIST

RR 700 MODEL SERIES S & J EXPLODED VIEW OPERATOR CHANNEL ASSEMBLY

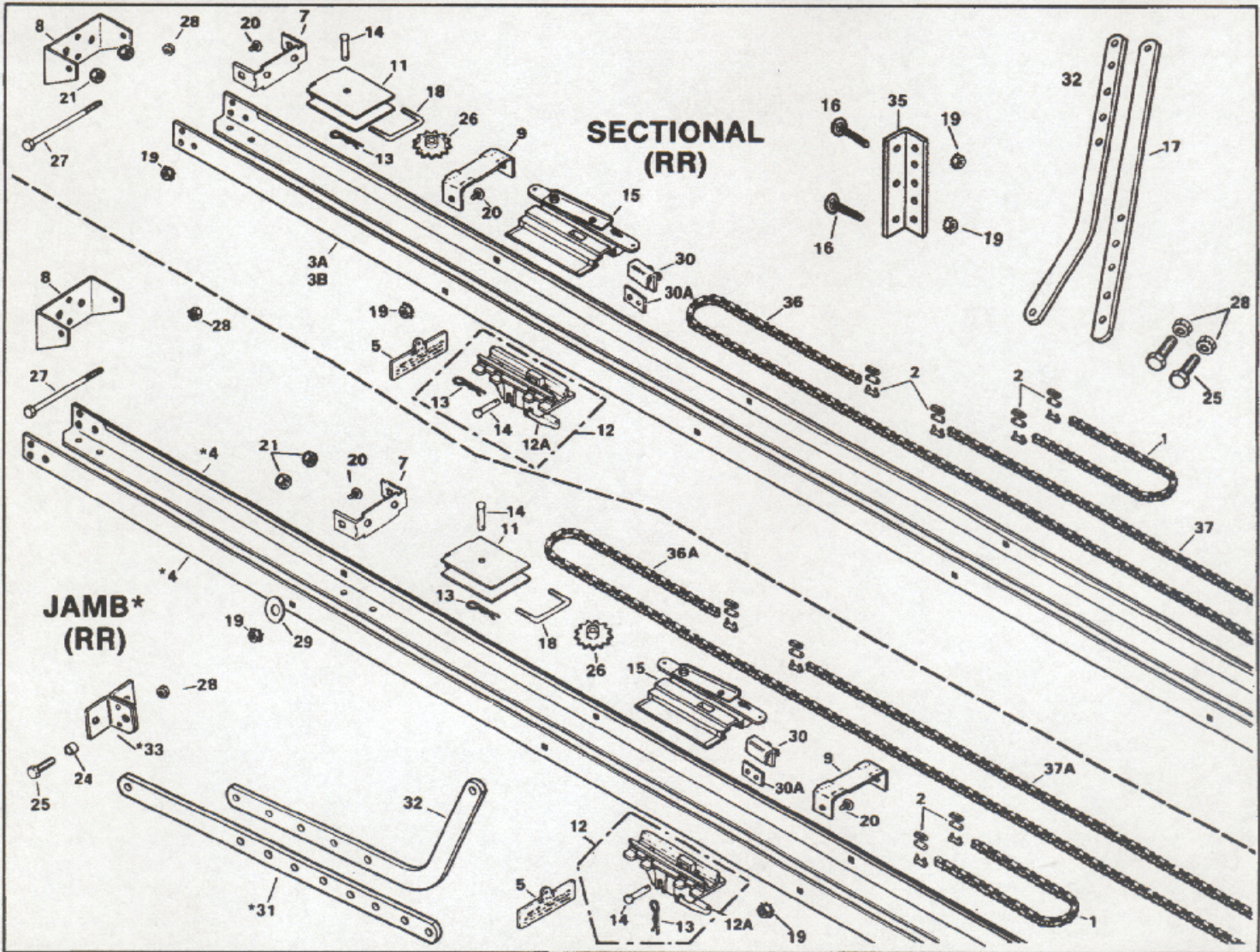

REF.	PART NO.	DESCRIPTION	QTY.
1	A6753	CHAIN, 15.5" (SHIPPED WITH HEAD ASSEMBLY)	1
2	8526-000	MASTER LINK	4
3A	A7870	CHANNEL SECT. (SECT'L) 113.5" HEMMED	2
3B	A7901	CHANNEL SECT. (8" SECT'L) 126.125" HEMMED	2**
*4	A7871	CHANNEL SECT. (JAMB), 90° HEMMED	2
5	A6577	TROLLEY RELEASE HANDLE	1
7	A7875	CHANNEL ADJUST BRACKET	1
8	A7952	HEADER BRACKET	1
9	A7790	SPREADER BRACKET	(3-4)**
11	A7216	IDLER SPROCKET RETAINER	1
12	A7805	TROLLEY SLIDE ASSY. COMPLETE	1
12A	A7207	LATCH REPLACEMENT KIT	1
13	7311-000	#3 HITCH PIN	2
14	7330-000	5/16 x 1-1/8 CLEVIS PIN	2
15	A7809	TROLLEY ASSY. (NO CHAIN)	1
		TROLLEY ASSYS. (CHAIN INCLUDED):	1
	A7957	(WITH 121.5" + 86.5")	
	A7958	(WITH 134.5" + 98.5")	
	A7814	(WITH 54.5" + 75.5")	
16	7100-000	1/4-20 X 2" FULL THD CARR BOLT	2
17	A6801	17" STRAIGHT DOOR ARM (SHIPPED WITH HEAD ASSEMBLY)	1
18	A6702	U-BOLT	1
19	A7603	1/4-20 KEPS NUT	14**
20	A6761	1/4-20 x 1/2 CARRIAGE BOLT	14**
21	7282-000	1/4-20 NYLOCK NUT	2

REF.	PART NO.	DESCRIPTION	QTY.
24	A6253	DOOR ARM BUSHING	1
25	7127-000	5/16-18 x 1" HEX BOLT	3
26	A6722	IDLER SPROCKET	1
27	A6763	5/16-18 x 4-1/2 HEX BOLT	1
28	A7602	5/16-18 KEPS NUT	4
29	7800-000	1/4" FLAT WASHER	2
30	A7005	POSI-LOCK STOP ASSEMBLY	1
30A	A7924	POSI-LOCK SPACER	1
*31	A6487	25" STRAIGHT ARM	1
32	A6305	17" CURVED DOOR ARM (PACKED WITH HEAD)	1
*33	A7566	DOOR BRACKET, JAMB (RIVETED)	1
35	B6195	DOOR BRACKET	1
36	A7953	CHAIN 134.5"	1
	A7954	CHAIN 121.5"	1
36A	A6758	CHAIN 75.5"	1
37	A7955	CHAIN 98.5"	1
	A7956	CHAIN 86.5"	1
37A	A6791	CHAIN 54.5"	1

PARTS IN YELLOW ARE NLA 8/10/00

Note: Asterisk (*) denotes Jamb Channel (RR) Parts
 **Depends on the channel type for quantity used.