

Installation Manual

MM600 ET-PRO by... **MIGHTY MULE** AUTOMATIC GATE OPENER

AMERICA'S #1 DIY GATE OPENER

SINGLE GATE OPENER SYSTEM

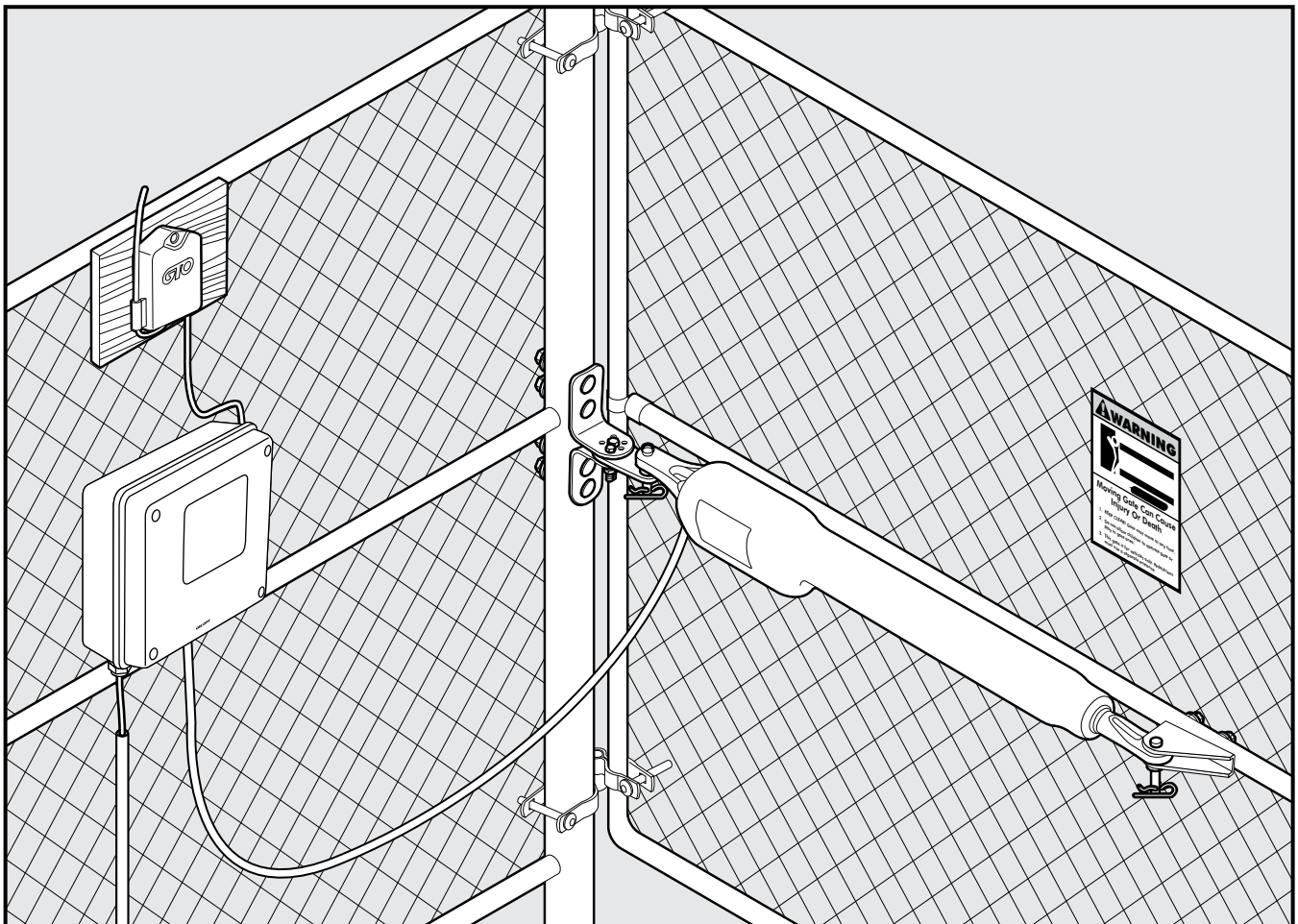

Warning!

This equipment is similar to other gate or door equipment and meets or exceeds Underwriters Laboratory Standard 325 (UL 325). However, gate equipment has hazards associated with its use and therefore by installing this product the installer and user accept full responsibility for following and noting the installation and safety instructions. Failure to follow installation and safety instructions can result in hazards developing due to improper assembly. You agree to properly install this product and that if you fail to do so Gates That Open, LLC shall in no event be liable for direct, indirect, incidental, special or consequential damages or loss of profits whether based in contract tort or any other legal theory during the course of the warranty or at any time thereafter. The installer

and/or user agree to assume responsibility for all liability and use of this product releasing Gates That Open, LLC from any and all liability. If you are not in agreement with this disclaimer or do not feel capable of properly following all installation and safety instructions you may return this product for full replacement value.

READ ALL INSTRUCTIONS CAREFULLY AND COMPLETELY before attempting to install and use this automatic gate opener. This gate opener produces a high level of force. Stay clear of the unit while it is operating and exercise caution at all times.

All automatic gate openers are intended for use on vehicular gates only.

The Mighty Mule® Gate Opener is intended for use with vehicular swing gates. The opener can be used in Class I, Class II, Class III and Class IV.

Vehicular Gate Opener Class Categories

Residential Vehicular Gate Opener-Class I:

A vehicular gate opener (or system) intended for use in a home of one-to-four single family dwelling, or a garage or parking area associated therewith.

Commercial/General Access Vehicular Gate Opener-Class II:

A vehicular gate opener (or system) intended for use in a commercial location or building such as a multifamily housing unit (one or more single family units), hotel, garages, retail store, or other building servicing the general public.

Industrial/Limited Access Vehicular Gate Opener-Class III:

A vehicular gate opener (or system) intended for use in an industrial location or building such as a factory or loading dock area or other locations not intended to service the general public.

Restricted Access Vehicular Gate Opener-Class IV:

A vehicular gate opener (or system) intended for use in a guarded industrial location or building such as an airport security area or other restricted access locations not servicing the general public, in which unauthorized access is prevented via supervision by security personnel.

Table of Contents

PLEASE READ THIS FIRST	1
IMPORTANT SAFETY INFORMATION	2
TECHNICAL SPECIFICATIONS	9
BEFORE YOU BEGIN	10
Check Direction of Gate Swing	10
Check Existing Gate Size and Material	10
Check for Proper Gate Installation	10
Column Installation Information	11
Items Included	11
Tools Needed	12
Items Not Included	12
GATE OPENER INSTALLATION	13
Mounting Pull-to-Open Opener to Gate	13
Closed Position Stop Plate Installation	15
Mounting Push-to-Open Opener to Gate	16
Closed Position Stop Plate Installation	18
CONTROL BOX INSTALLATION	19
Control Box Installation	19
Receiver Installation	20
Connecting the Battery	21
Transformer Wiring Installation	21
SOLAR PANEL INSTALLATION	23
CONTROL BOX SETTINGS	25
DIP Switches	25
Setting Pull-to-Open (Closed) Gate Limit	26
Resetting Closed Gate Limit	26
Setting Push-to-Open (Open) Gate Limit	27
Resetting Open Gate Limit	27
Setting Obstruction Stall Force and Auto Close Time	28
Setting Your Personal Code	28
CONNECTING ADDITIONAL DEVICES	30
Input Connections	31
Connecting Accessories	32
Connecting GTO Automatic Lock	32
Connecting Other Auxiliary Devices	32
MAINTENANCE & TROUBLESHOOTING	32
Maintenance Tips	32
Troubleshooting Guide	33

Please Read This First!

Thank you for purchasing a Mighty Mule® E-Z Gate Opener—GTO's "do-it-yourself" automatic gate opener! When correctly installed and properly used, your Mighty Mule® E-Z Gate Opener will give you many years of reliable service. Please read the following information and watch the enclosed video to ensure you have the correct system for your particular needs. Furthermore, this manual and the DVD will enable you to properly install your Mighty Mule® E-Z Gate Opener.

The Mighty Mule® E-Z Gate Opener is designed for installation on a pull-to-open single leaf gate (gates that open into the property). By purchasing an accessory bracket, the Mighty Mule® E-Z Gate Opener can accommodate a push-to-open single leaf gate (gates that open out from the property). The gate must not exceed 18 feet in length and weigh more than 350 pounds or exceed 8 feet in length and weigh more than 850 pounds (please see Technical Specifications on page 9). The Mighty Mule® E-Z Gate Opener can be used on vinyl, aluminum, chain link, farm tube, and wrought iron gates. Use on solid (wood) gates is not recommended. Solid surface gates have a high resistance to the wind. If the wind is strong enough, the opener will obstruct and stop.

The Mighty Mule® E-Z Gate Opener accommodates extra transmitters, digital keypads, solar panels, push buttons, automatic gate locks, and other access control products. These optional accessories (see the enclosed Mighty Mule® Accessory Catalog) are available at most stores. Your store should be able to special order any accessory not in stock. If your store cannot

special order accessories, please call the GTO Sales Department (800-543-GATE).

The Mighty Mule® E-Z Gate Opener features adjustable obstruction sensing. This safety feature makes the gate stop and reverse direction within 2 seconds when it comes in contact with an obstruction. MIN is the factory setting; meaning the gate will exert the minimum force on an obstruction before it stops and reverses direction.

The Mighty Mule® E-Z Gate Opener also has an adjustable auto-close feature. After the gate reaches the fully open position, it can be set to remain open up to 120 seconds before automatically closing. Pressing the transmitter button at any time after the gate opens fully will cause it to close immediately. OFF is the factory setting; meaning the gate will stay open until you press the transmitter (or keypad, etc.) again.

PLEASE NOTE—If your application requires any of the following:

- Swing gates longer than 18 feet or weighing more than 850 pounds
- Slide gates
- Heavy duty or commercial uses
- Professional installation

Go to www.gtoinc.com for a dealer or retailer near you or call GTO at (800) 543-GATE [4283] or (850) 575-0176 for information about our GTO Access Systems line of gate openers and accessories. Our Sales Department will be glad to give you the name and phone number of a GTO Access Systems dealer near you.

BEFORE YOU BEGIN TO INSTALL YOUR AUTOMATIC GATE OPENER:
watch the enclosed video and read these instructions carefully and completely to become familiar with all parts and installation steps. The video is only designed as an overview of the installation procedure. You must read the installation manual for detailed instructions on gate opener safety and proper use of the gate opener.





Important Safety Information



Because automatic gate openers produce high levels of force, consumers need to know the potential hazards associated with improperly designed, installed, and maintained automated gate opener systems. **Keep in mind that the gate opener is just one component of the total gate operating system.** Each component must work in unison to provide the consumer with convenience, security, and safety.

This manual contains various safety precautions and warnings for the consumer. Because there are many possible applications of the gate opener, the safety precautions and warnings contained in this

manual cannot be completely exhaustive in nature. They do, however, provide an overview of the safe design, installation, and use of this product.

CAREFULLY READ AND FOLLOW ALL SAFETY PRECAUTIONS, WARNINGS, AND INSTALLATION INSTRUCTIONS TO ENSURE THE SAFE SYSTEM DESIGN, INSTALLATION, AND USE OF THIS PRODUCT.



Precautions and warnings in this manual are identified with this warning symbol. The symbol identifies conditions that can result in damage to the opener or its components, serious injury, or death.

Because GTO automatic gate openers are only part of the total gate operating system, it is the responsibility of the consumer to ensure that the total system is safe for its intended use.

Manually Opening and Closing Gate



CAUTION: The gate will move freely and uncontrolled when the gate opener is removed from the gate. **ONLY** disconnect the opener when the control box power switch is OFF and the gate is NOT moving.

Disconnecting the Opener

1. Turn control box power switch OFF.
2. Remove hairpin clip, clevis pin, and bushing from either the front or rear mounting point.
3. Remove the opener from the mount.

The gate can be opened and closed manually when the opener is disconnected.

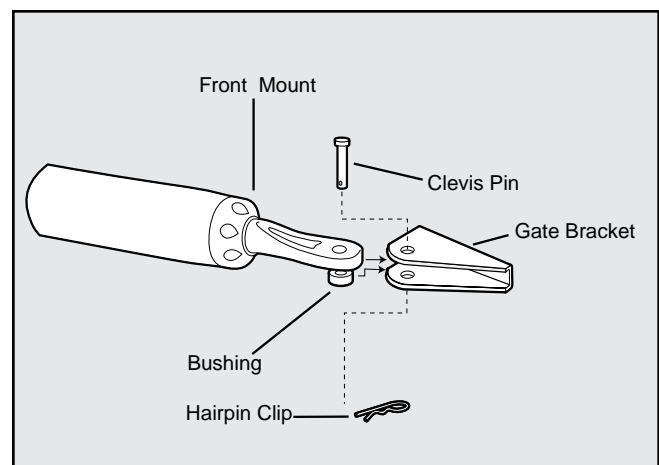

NOTE: Substitute a **Pin Lock** for the clevis pin on the front mount of the gate opener to prevent unauthorized removal of the opener from the gate (see accessory pages in back of this book).

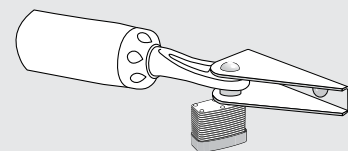



Important Safety Information



For the Consumer

WARNING: To reduce the risk of injury or death:

- 1. READ AND FOLLOW ALL INSTRUCTIONS.** Failure to meet the requirements set forth in the instruction manual could cause severe injury or death, for which the manufacturer cannot be held responsible.
- When designing a system that will be entered from a highway or main thoroughfare, make sure the system is placed far enough from the road to prevent traffic congestion.
- The gate must be installed in a location that provides adequate clearance between it and adjacent structures when opening and closing to reduce the risk of entrapment. Swinging gates **must not** open into public access areas.
- The gate and gate opener installation **must comply with any applicable local codes.**
- Make sure the gate has been properly installed and swings freely in both directions. Repair or replace all worn or damaged gate hardware prior to installation. A freely moving gate will require less force to operate and will enhance the performance of the opener and safety devices used with the system (*see page 10*).
- Review the operation of the system to become familiar with its safety features. Understand how to disconnect the opener for manual gate operations (*see page 2*).
- This gate opener is intended for **vehicular gates ONLY**. A separate entrance or gate must be installed for pedestrian use (*see page 7*).
- Always keep people and objects away from the gate and its area of travel. **NO ONE SHOULD CROSS THE PATH OF A MOVING GATE.**

I. Before Installation

- Verify this opener is proper for the type and size of gate, its frequency of use and proper class rating.

- Pay close attention to the diagram below and be aware of these areas at all times.

PULL-TO-OPEN INSTALLATION

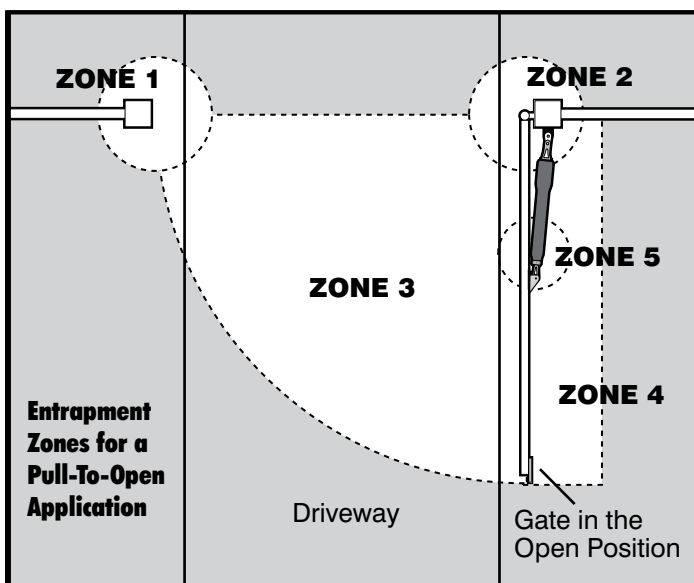

PUSH-TO-OPEN INSTALLATION

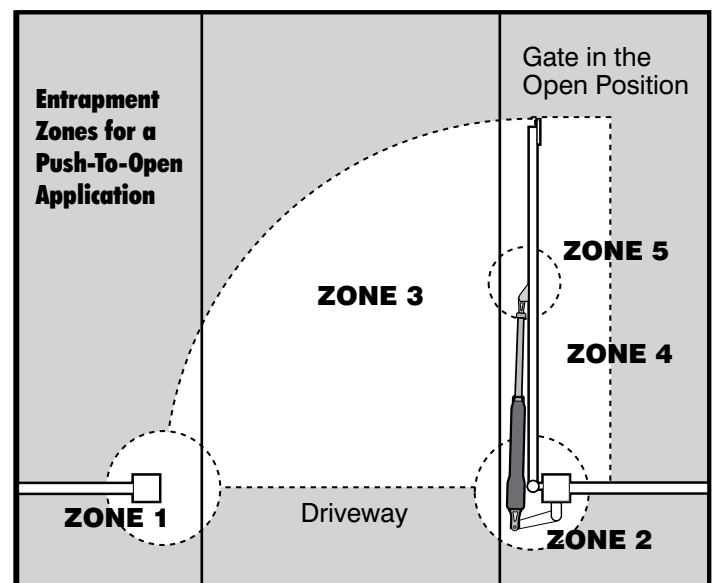



Important Safety Information



For the Consumer

Entrapment Zones for a proper Pull-To-Open installation:

Zone 1 – leading edge of the gate and the fence post.

Zone 2 – between the gate and the gate post.

Zone 3 – the path of the gate.

Zone 4 – the space between the gate in the open position and any object such as a wall, fence, tree, etc.

Zone 5 – pinch points between the opener and gate.

II. During Installation

1. Install the gate opener on the inside of the property and fence line. **DO NOT** install an opener on the outside of the gate where the public has access to it.
2. Be careful with moving parts and avoid close proximity to areas where fingers or hands could be pinched.
3. Devices such as contact sensors (safety edges) and non contact sensors (photo beams) provide additional protection against entrapment.
4. If push buttons or key switches are installed, they should be within sight of the gate, yet located at least 10 feet from any moving part of the gate (see diagram below). *Never install any control device where a user will be tempted to reach through the gate to activate the gate opener.*
5. Do not activate your gate opener unless you can see it and can determine that its area of travel is clear of people, pets, or other obstructions. Watch the gate through its entire movement.
6. Secure outdoor or easily accessed gate opener controls in order to prohibit unauthorized use of the gate.

NEVER install any control device within gray area

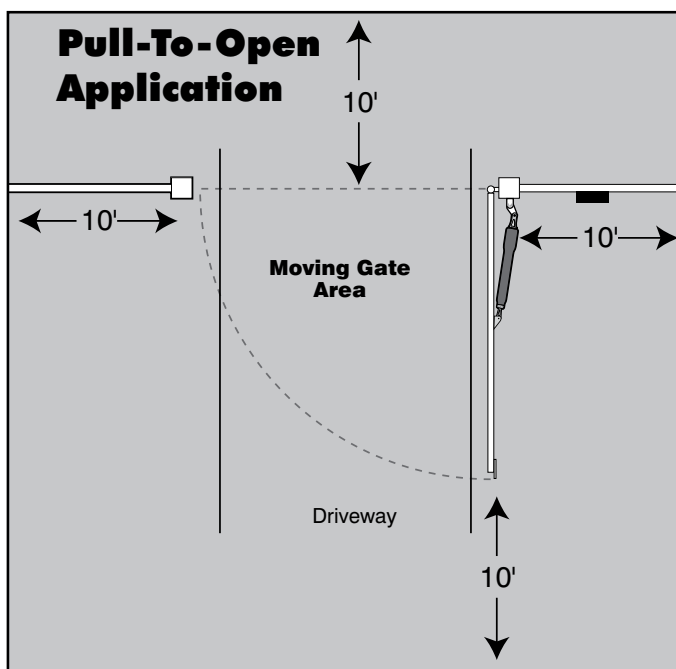

NEVER install any control device within gray area

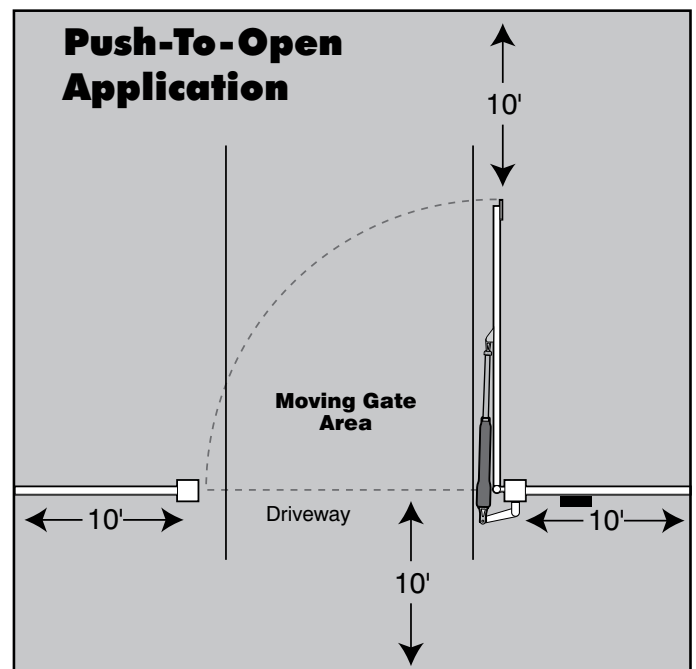



Important Safety Information



For the Consumer

III. After Installation

1. Attach the **warning signs** (included) to each side of the gate to alert the public of automatic gate operation. It is your responsibility to post warning signs on both sides of your gate. If any of these signs or warning decals becomes damaged, illegible, or missing, replace them immediately. Contact GTO for free replacements.
2. The gate is automatic and could move at any time, posing serious risk of entrapment. No one should be in contact with the gate when it is moving or stationary.
3. Do not attempt to drive into the gate area while the gate is moving; wait until the gate comes to a complete stop.
4. Do not attempt to “beat the gate” while the gate is closing. This is extremely dangerous.
5. Do not allow children or pets near your gate. **Never let children operate or play with gate controls.** Keep the remote control away from children and unauthorized users; store controls where children and unauthorized users do not have access to them.
6. **KEEP GATES PROPERLY MAINTAINED.** Always turn power to operator OFF before performing any maintenance. Clean the push-pull tube with a soft, dry cloth and apply silicone spray to it at least once per month.
7. Service the gate and gate operator regularly. Grease hinges, spray push pull tube with high quality silicone spray monthly and replace the battery every 2-3 years.
8. To operate this equipment safely, YOU must know how to disconnect the operator for manual gate operation (see page 2). If you have read the instructions and still do not understand how to disconnect the operator, contact the GTO Service Department.
9. Disconnect the operator **ONLY** when the power is **TURNED OFF** and the gate is **NOT** moving.
10. Make arrangements with local fire and law enforcement for emergency access.
11. Distribute and discuss copies of the **IMPORTANT SAFETY INFORMATION** section of this manual with all persons authorized to use your gate.
12. **IMPORTANT: Save these safety instructions. Make sure everyone who is using or will be around the gate and gate operator are aware of the dangers associated with automated gates. In the event you sell the property with the gate operator or sell the gate operator, provide a copy of these safety instructions to the new owner.**

Should you lose this manual, a copy can be obtained by downloading one from the Mighty Mule® web site (www.mightymule.com), by contacting Gates That Open, LLC at 3121 Hartsfield Road, Tallahassee, Florida 32303 or by calling 1-800-543-4283 and requesting a duplicate copy. One will be provided to you for a nominal fee.



Important Safety Information



Secondary Means of Protection Against Entrapment

As specified by Gate Operator Safety Standard, UL 325 (30A.1.1), automatic gate operators shall have an inherent entrapment sensing system, and shall have provisions for, or be supplied with, at least one independent secondary means to protect against entrapment. The Mighty Mule 600 utilizes **Type A**, an inherent (i.e., built-in) entrapment sensing system as the **primary** type of entrapment protection. Also, the Mighty Mule 600 has **provisions for** the connection of **Type B2** protection to be used as the **secondary** type of entrapment protection, and is recommended.

1. For gate operators utilizing a contact sensor (e.g., safety edge sensor– Type B2) in accordance with UL 325 (51.8.4 [i]):

- A. One or more contact sensors shall be located at the leading edge, bottom edge, and post edge, both inside and outside of a vehicular swing gate system.
- B. A hard wired contact sensor shall be located and its wiring arranged so that the communication between the sensor and the gate operator is not subjected to mechanical damage.
- C. A wireless contact sensor such as one that transmits radio frequency (RF) signals to the gate operator for entrapment protection functions shall be located where the transmission of the signals is not obstructed or impeded by building structures, natural landscaping or similar obstruction. A wireless contact sensor shall function under the intended end-use conditions.

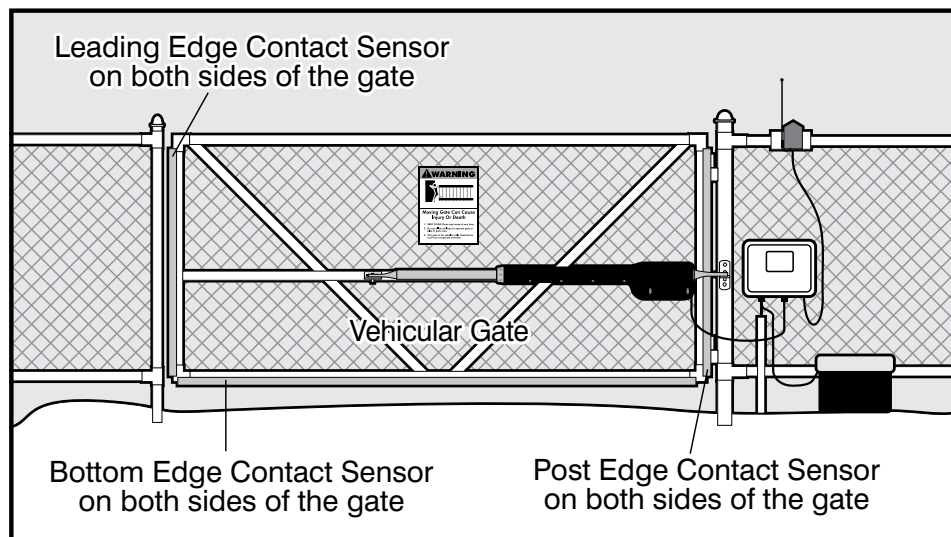

ENTRAPMENT ALARM (UL 325; 30A.1.1A)

The Mighty Mule 600 Automatic Gate Operator is designed to stop and reverse within 2 seconds when the gate comes in contact with an obstruction. Additionally, these operators are equipped with an audio entrapment alarm which will activate if the unit obstructs twice while opening or closing. This alarm will sound for a period of 5 minutes, or until the operator receives an intended signal from a hardwired entry/exit source (e.g. push button control or keypad) and the gate returns to a fully open or fully closed position. Turning the power switch on the control box OFF and back ON will also deactivate the alarm. Wireless controls such as transmitters and wireless keypads will not deactivate the alarm.



Important Safety Information



Required Safety Precautions for Gates

Install Warning Signs

Warning signs alert people of automatic gate operation and are **required** when installing the Mighty Mule 600 Automatic Gate Operator. Furthermore, a walk-through gate must be installed if pedestrian traffic is expected near the vehicular gate. We recommend using the **GTO Bulldog Pedestrian Gate Lock (FM143)**. Call the **GTO Sales Department** at 800-543-4283 for controlled access.

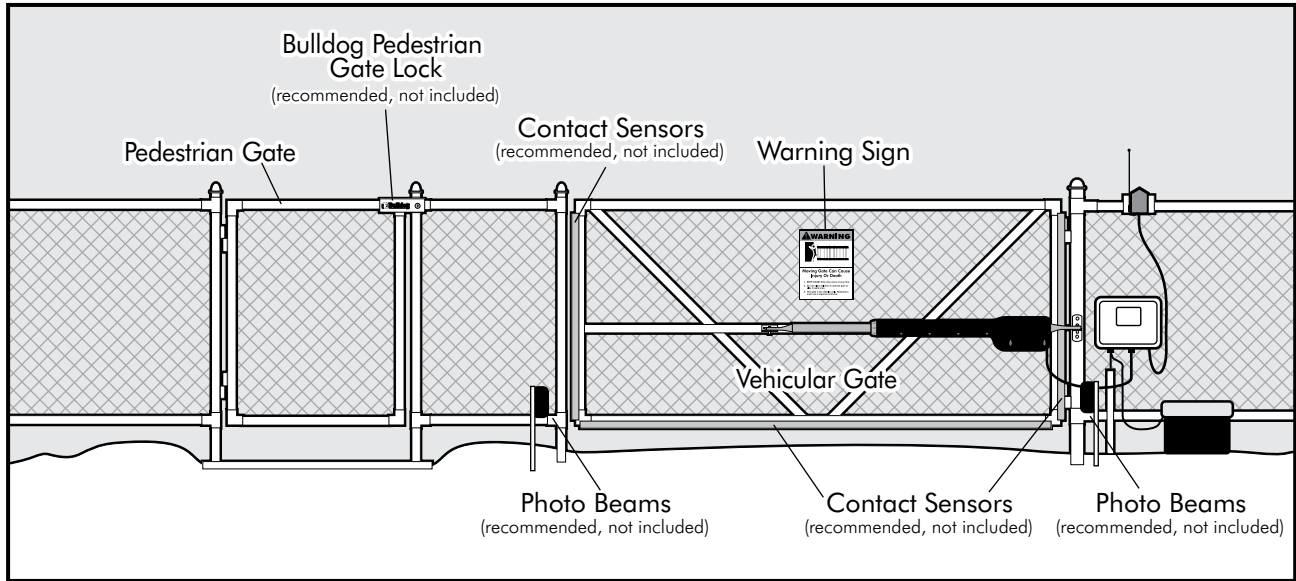

Entrapment Protection

GTO's inherent obstruction settings, even when properly adjusted, *may not be sensitive enough to prevent bodily injury in some circumstances*. For this reason, safety devices such as safety edge sensors (or photoelectric sensors), which stop and reverse gate direction upon sensing an obstruction, are suggested for enhanced protection against entrapment.

Warning Signs

The warning signs (at right) must be installed on both sides of the gate (see next page for details).





Important Safety Information



Required Safety Precautions for Gates

WARNING

Moving Gate Can Cause Injury Or Death

1. **KEEP CLEAR!** Gate may move at any time.
2. **Do not allow children to operate gate or play in gate area.**
3. **This gate is for vehicles only. Pedestrians must use a separate entrance.**

These warning labels should be found at the locations specified below. If any of them are missing, immediately contact GTO for replacements.

GTO DC SWING SERIES
 Conforms to UL 325 STANDARDS
 Maximum Gate: 850 lb. (226.7 kg); 18 ft. (4.8 m)
 Voltage: 12 Vdc; Frequency: 0 Hz; Power: 25 W
 Class I, II, III and IV Vehicular Swing Gate Operator.

Serial Number: **MM600-XXXXXXX**
 Gates That Open, LLC • Tallahassee, Florida USA

Product identification label (1) installed on side of control box.

Warning signs (2 enclosed) to be installed on each side of the gate (3–5 feet above the bottom of the gate).

MM600 ET-PRO
AUTOMATIC GATE OPENER

by... **MIGHTY MULE**
AMERICA'S #1 DIY GATE OPENER

1-800-543-GATE (4283) • www.mightymule.com

WARNING

MOVING GATE
Can Cause Injury or Death

1. **KEEP CLEAR!** Gate may move at any time.
2. **Do not allow children to operate gate or play in gate area.**
3. **This gate is for vehicles only. Pedestrians must use separate entrance.**

Logo and warning labels (2) installed on each side of opener housing.

Before You Begin

Check Direction of Gate Swing

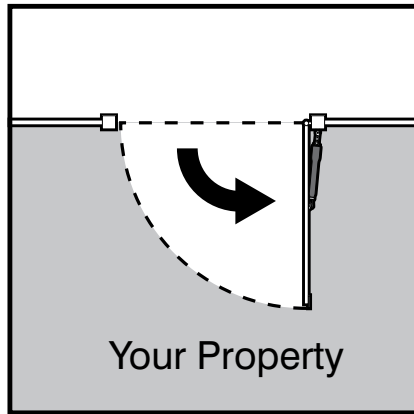

Pull-to-Open Option
Instructions begin on
page 13

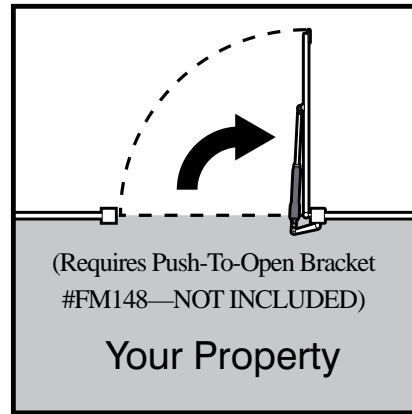

Push-to-Open Option
Instructions begin on
page 16

Check Existing Gate Size and Material

• **Gate size:** Up to 18 feet or up to 850 lbs—See chart on page 9.

• **Type of gate material:** Vinyl, aluminum, chain link, farm tube, wrought iron, wood (not recommended for solid surface gates).

IMPORTANT: Check for Proper Gate Installation

For the Mighty Mule® to work properly, gate must be plumb, level, set in concrete, swing freely and not touch the ground and have good working hinges.

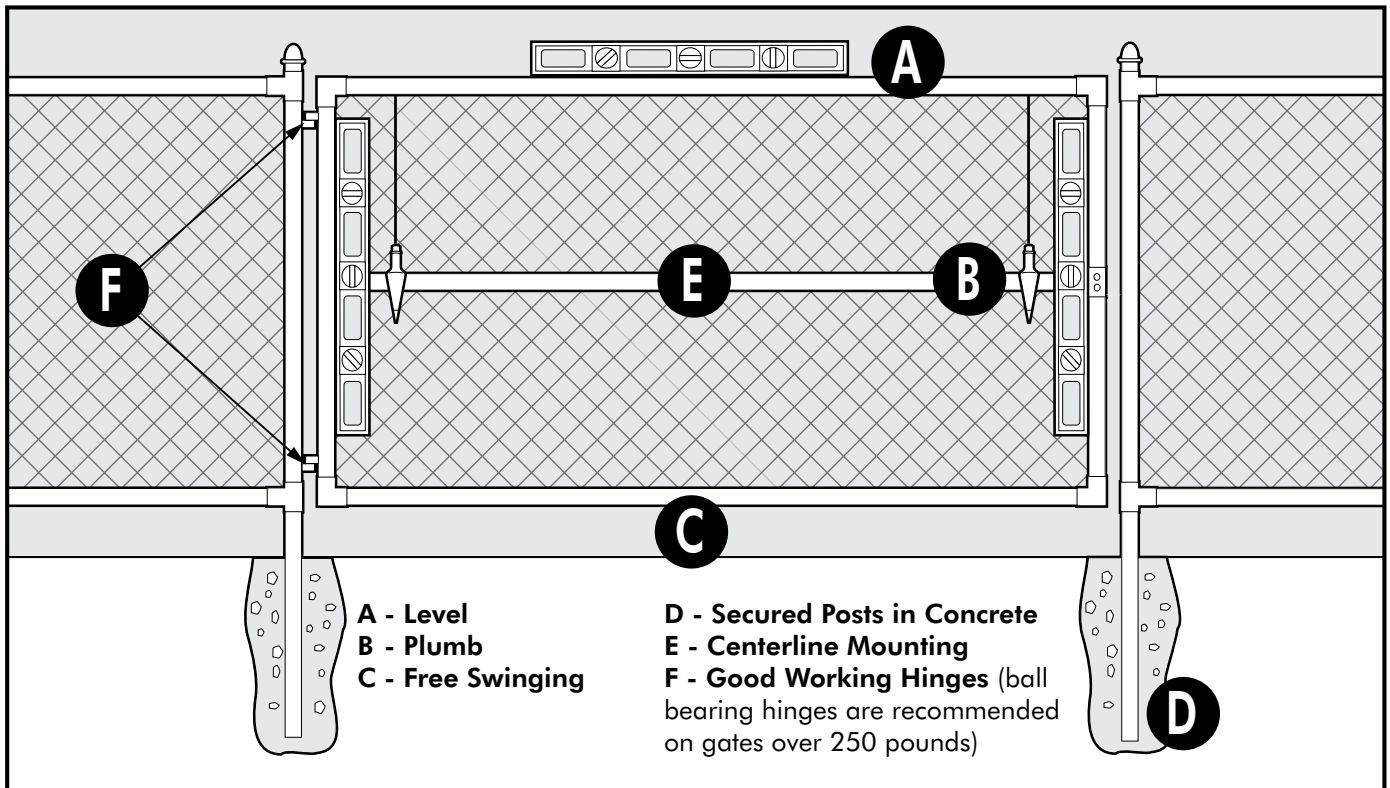

Before You Begin

Column Installation Information

IF THIS OPENER WILL BE USED WITH GATES THAT ARE MOUNTED ON MASONRY, BRICK, OR ROCK (etc.) COLUMNS, READ THE FOLLOWING CAREFULLY BEFORE PROCEEDING

A. The simplest solution is to install the opener in a push-to-open con guration (requires push-to-open bracket, see accessory catalog). The minimum clearance is easier to achieve and clearance is no longer a problem, since the opener will be pushing the gate away from the column instead of pulling it toward the column. It is recommended that you place a steel plate between the opener mounting brackets and masonry surface for additional strength.

B. If a push-to-open installation is impossible due to traf c hazards, terrain, etc., another option is to re-hang the gate. You may hang it on a post, either in the center of the column or at the back corner, or move the gate to the back corner of the columns.

C. The most dif cult solution is to cut a notch in the column to accommodate the opener and power cable. This job is NOT for the inexperienced!

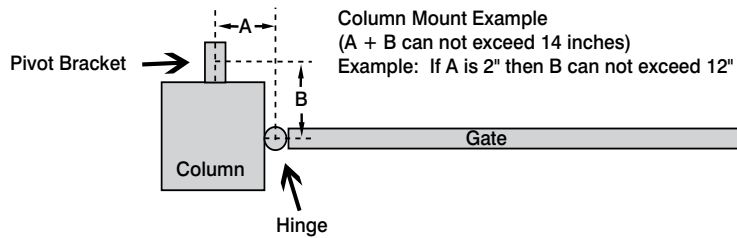

Items Included

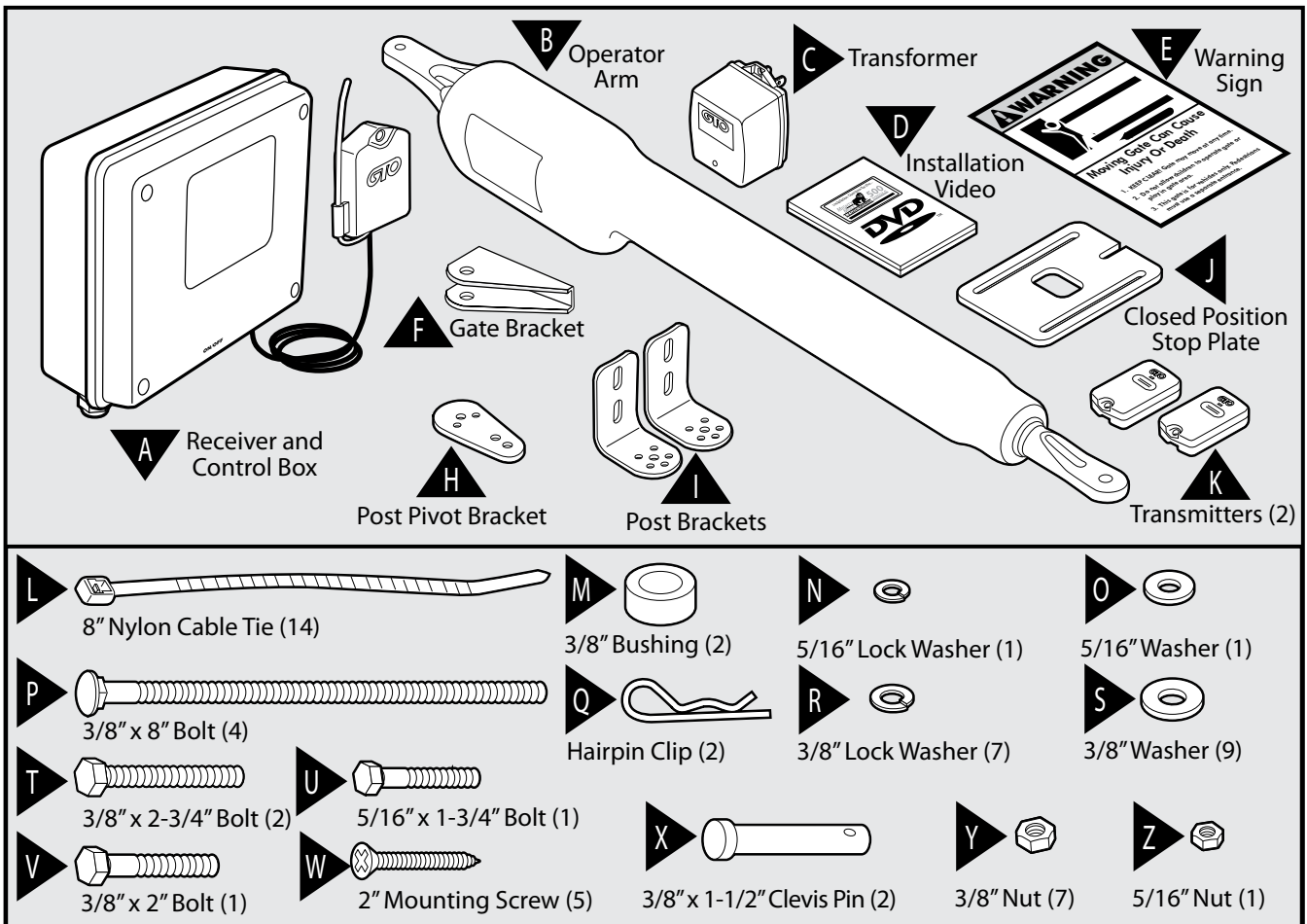

Before You Begin

Tools Needed

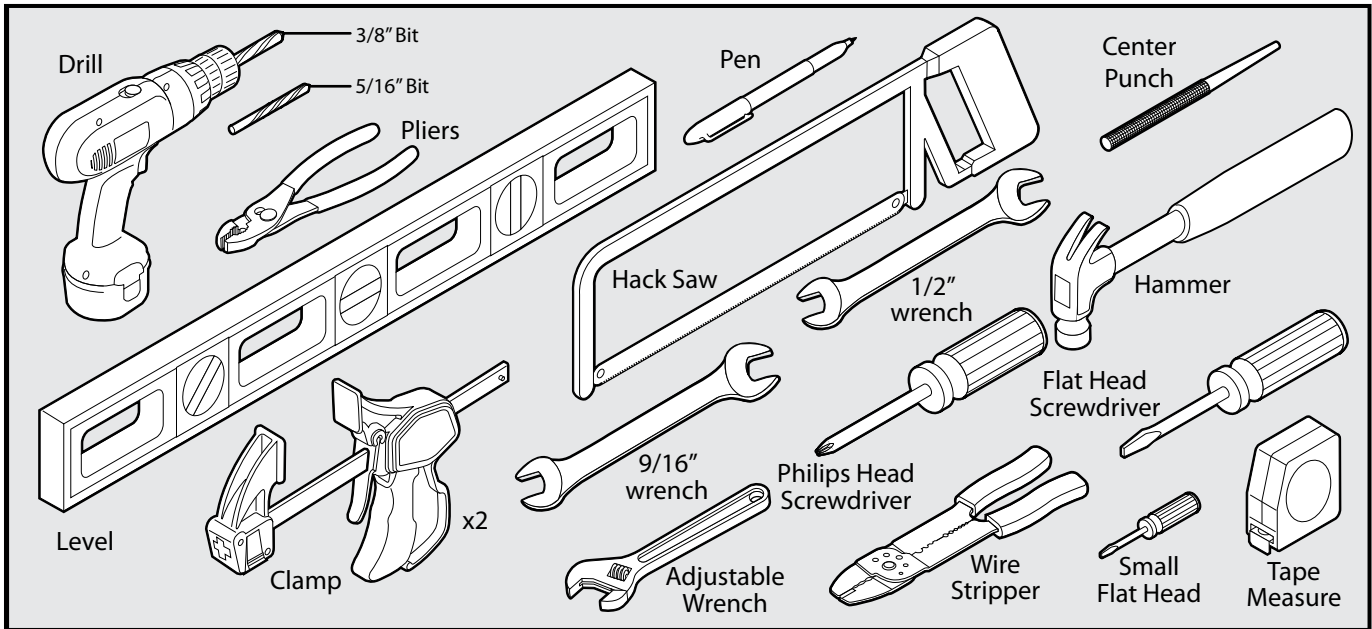

Items Not Included

- 12 Volt lawn tractor or automotive battery and a weather proof case.
- Low voltage wire will be needed to run from the transformer to the control box; length depends upon the distance between the transformer power supply and the control box. See Transformer Wiring Installation on page 20, and the accessory catalog.
- PVC conduit.
- If your gate is more than 1000' away from an ac power source you will need to use at least one Mighty Mule® 5 watt solar panel to trickle charge the battery. See the accessory catalog (Do not use both transformer and solar).
- If you have thin walled tube or panel gates, see Recommended Reinforcement Examples in “Quick Reference Guide” after Step 3 of “Mounting Opener to Gate” section.
- Depending on the type of gate, a horizontal cross member or mounting plate may be needed to mount the front of the opener and gate bracket to the gate. See Gate Bracket Mounting Examples in “Quick Reference Guide” after Step 3 of “Mounting Opener to Gate” section.
- Surge protection for transformer.
- Some types of installations require u-bolts.
- If the gate is a push-to-open refer to page 16 in Installation Manual.
- Additional washers or a metal plate may be needed for wooden post.
- Weatherproof cover for outdoor outlet.
- Strain relief nuts for accessory devices.
- If post is more than 6”, bolts longer than 8” are needed.

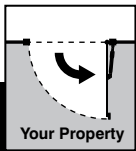

Gate Opener Installation

Mounting Pull-to-Open Opener to Gate

If you are installing a push-to-open gate opener - skip to page 16.

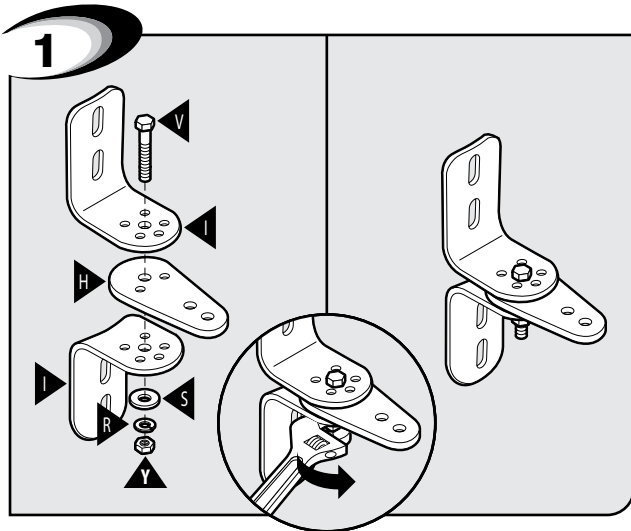

Assemble post bracket parts.

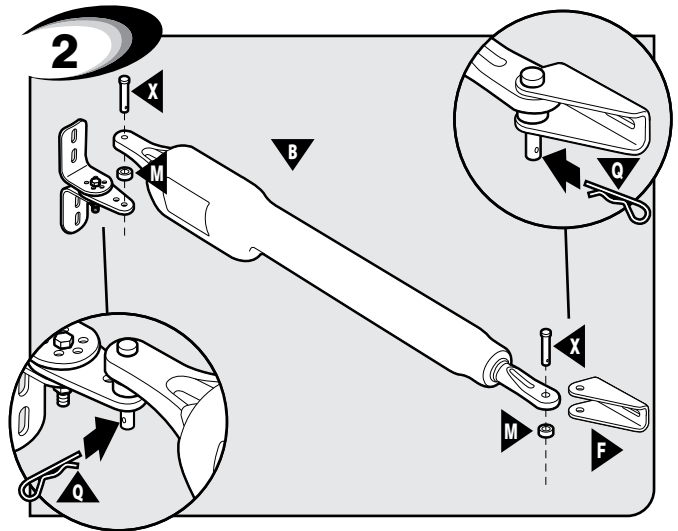

Attach opener to gate bracket and secure with required hardware.

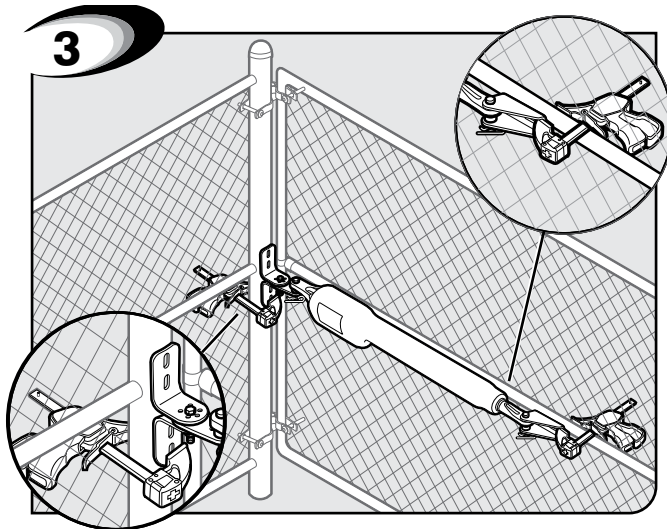

With Gate in **OPEN** position, using clamps, secure opener to gate post and center cross member of gate.

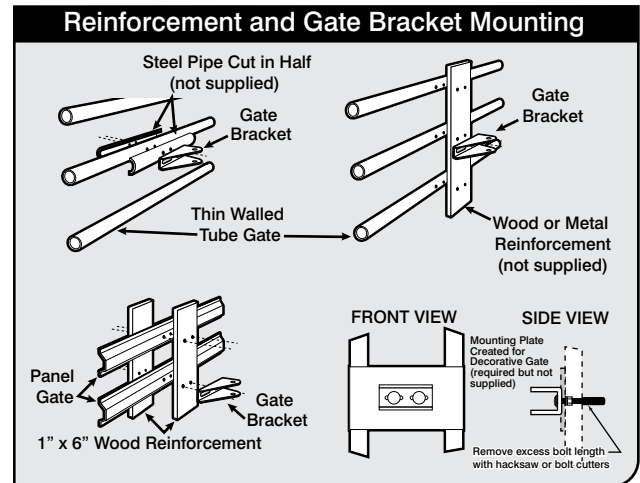

Recommended reinforcement and gate bracket mounting examples.

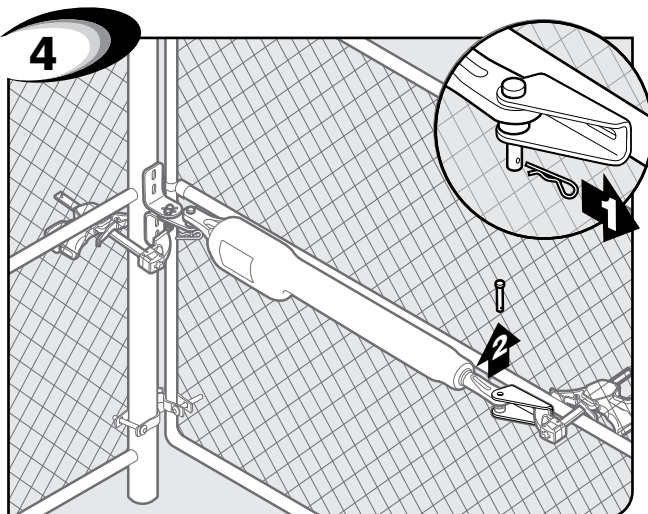

Remove clevis pin from the gate bracket and support loose opener.

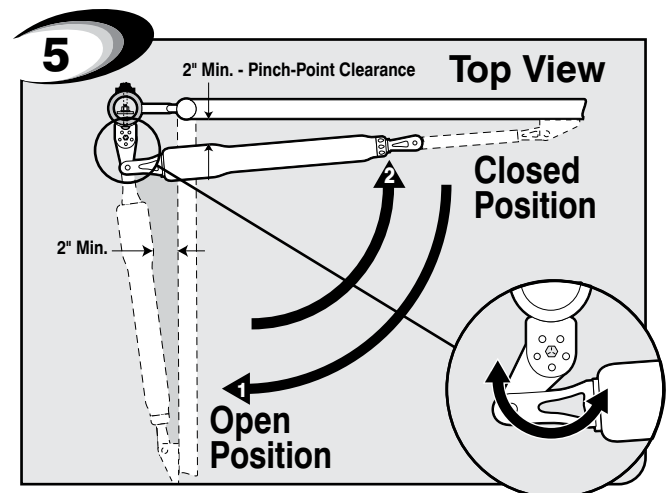

Swing gate to **CLOSED** position-check clearance/binding by inspecting alignment. *TIP: Turning the pivot bracket over gives more hole alignment options for the post pivot bracket assembly.*

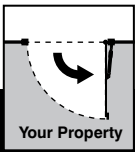

Gate Opener Installation

Mounting Pull-to-Open Opener to Gate

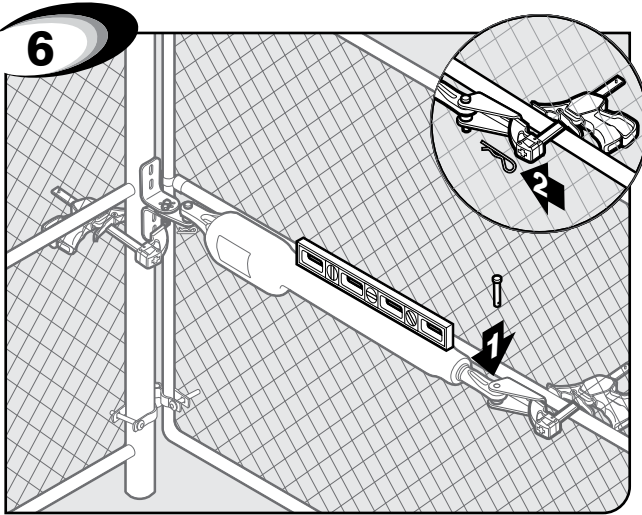

6
OPEN gate and reattach opener with clevis pin. Check for level. Clamp securely.

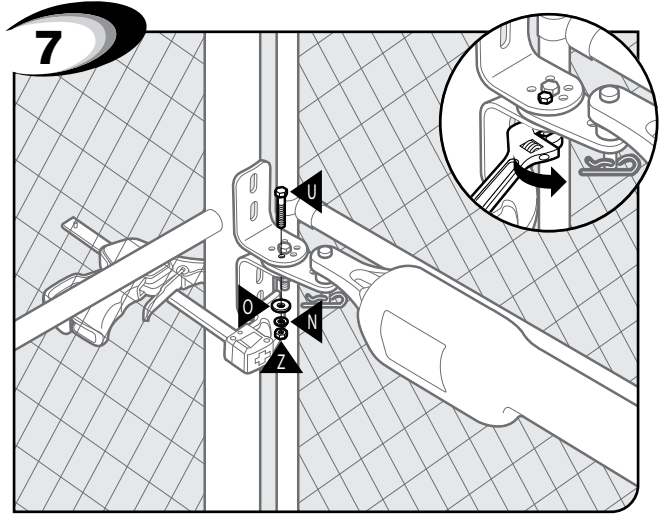

7
Secure post pivot bracket to post bracket when clearance is OK (Step 5) in both open and closed positions.

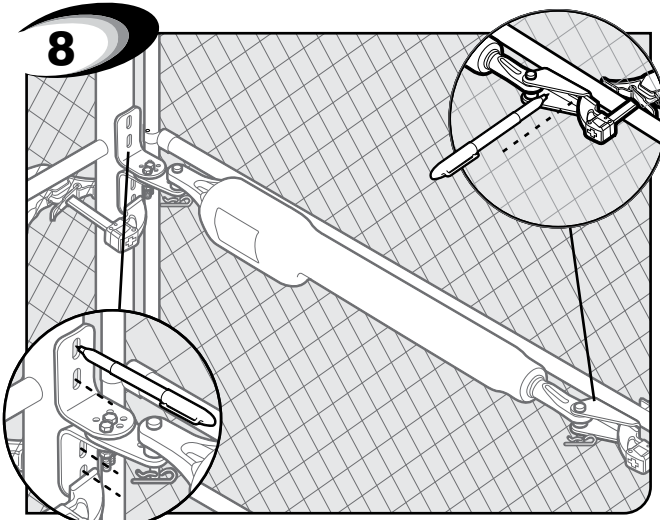

8
Mark middle of post bracket slots on fence post. Mark middle of gate bracket slots on gate cross support.

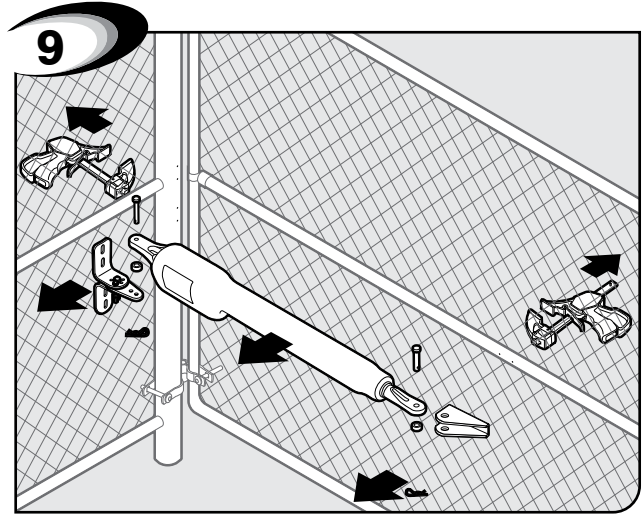

9
Remove clamps, post bracket, gate bracket, and opener. Then use a hammer and center punch to mark hole positions.

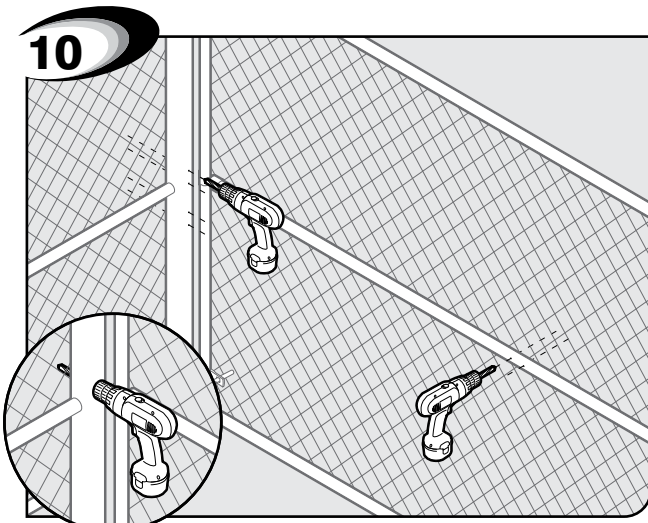

10
Drill holes completely through gate post and gate cross support.

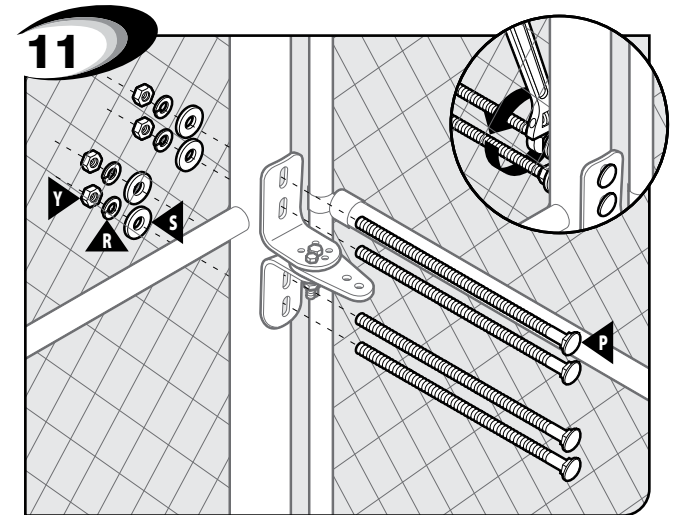

11
Attach post bracket assembly to fence post. *NOTE: Must be through bolted.*

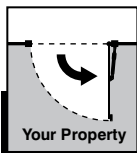

Gate Opener Installation

Mounting Pull-to-Open Opener to Gate

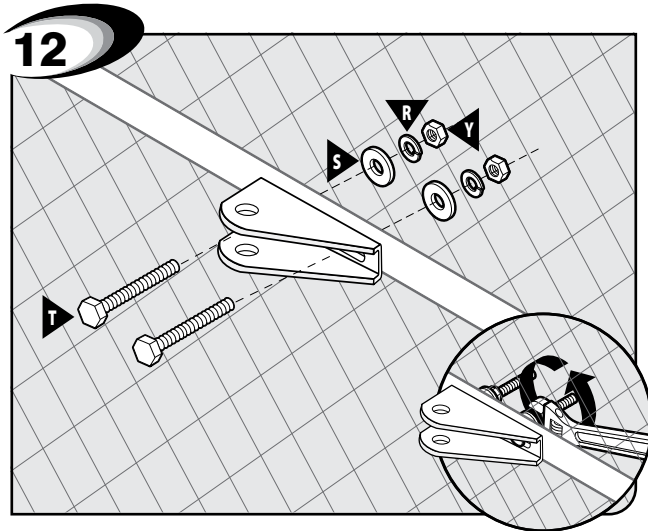

Attach gate bracket assembly to gate cross support.

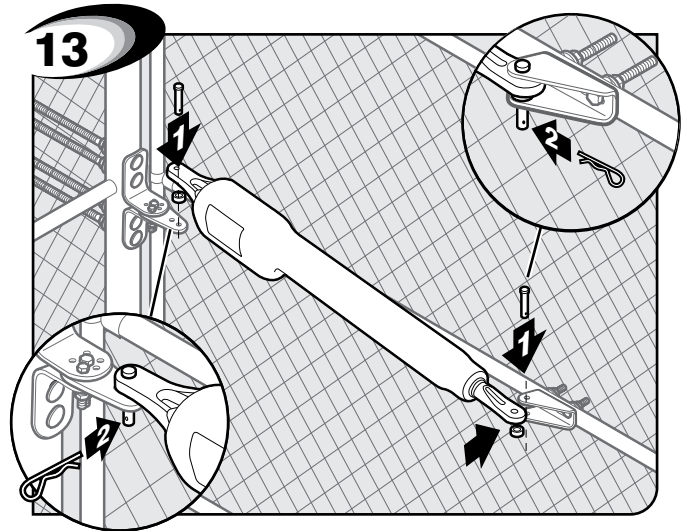

Attach and secure opener assembly to brackets.

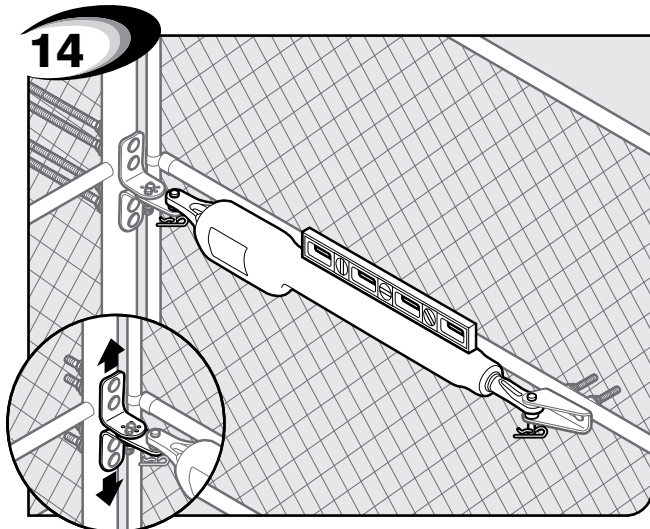

Check for level. Adjust post bracket if necessary.

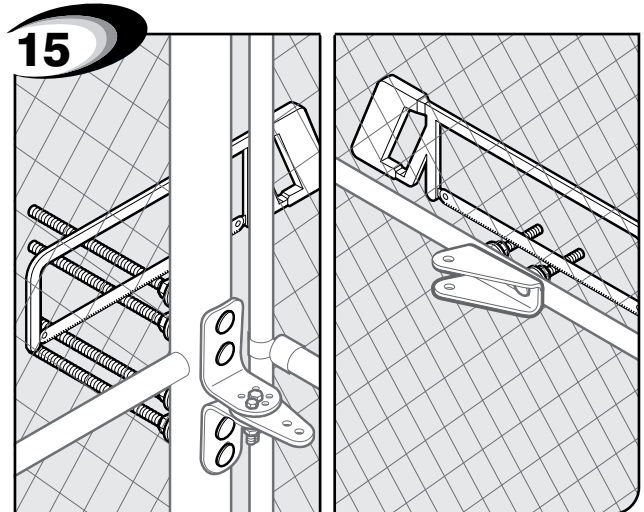

Tighten all bolts and remove excess length on post and gate bracket bolts with hacksaw.

Closed Position Stop Plate Installation

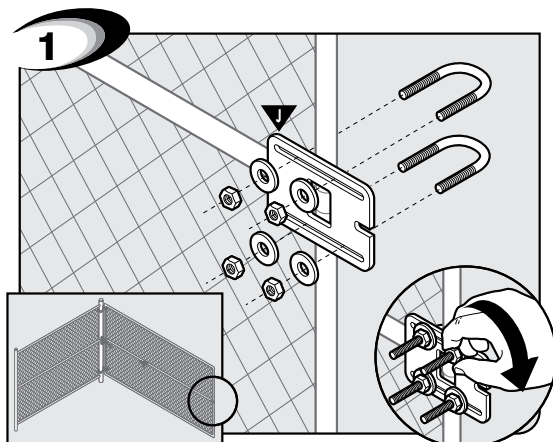

Fully open gate. Attach gate stop with one of the following:
• U-bolts—tube and chain link gates (Not included)
• Wood/lag screws—flat aluminum/wood supports (Not included).
Do not tighten.

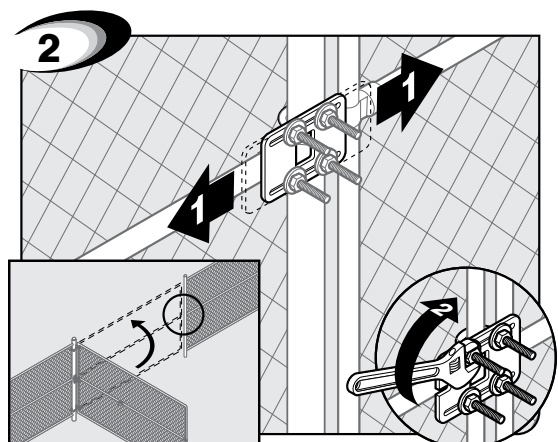

Position gate stop with gate CLOSED to fence post. Tighten fasteners. Cut off excess bolt length.



Gate Opener Installation

Mounting Push-to-Open Opener to Gate

If you are installed a pull-to-open gate opener - skip to page 19.

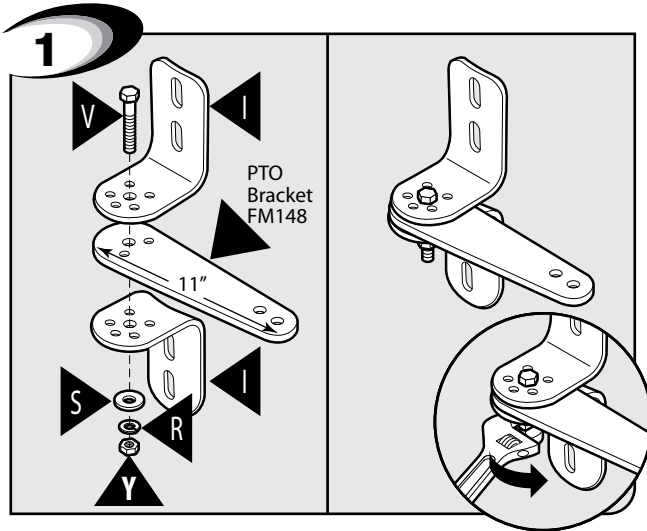

Assemble post bracket parts. **NOTE:** A Push-to-Open Bracket FM148 is required for this type of installation (not included).

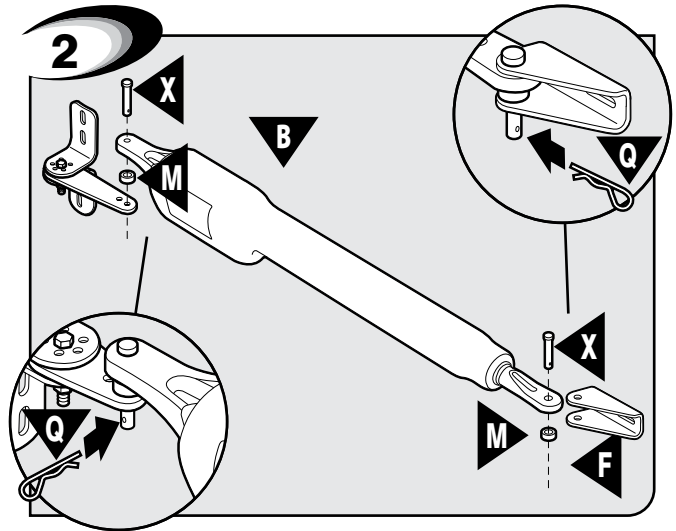

Attach opener to gate bracket and secure with hardware required.

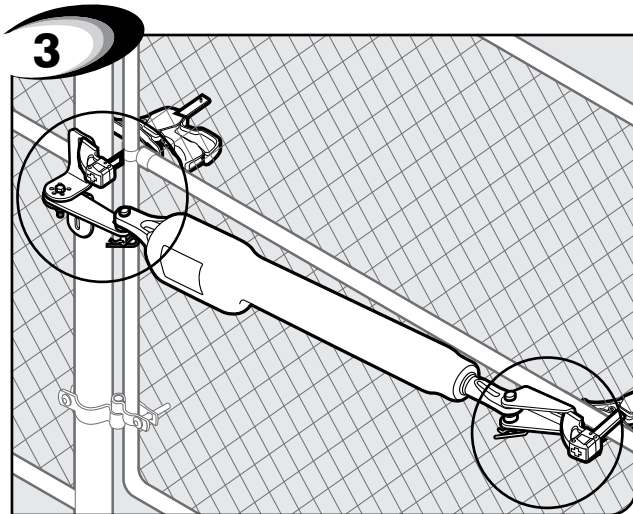

With gate in CLOSED position, using clamps, secure opener to gate post and center cross member of gate.

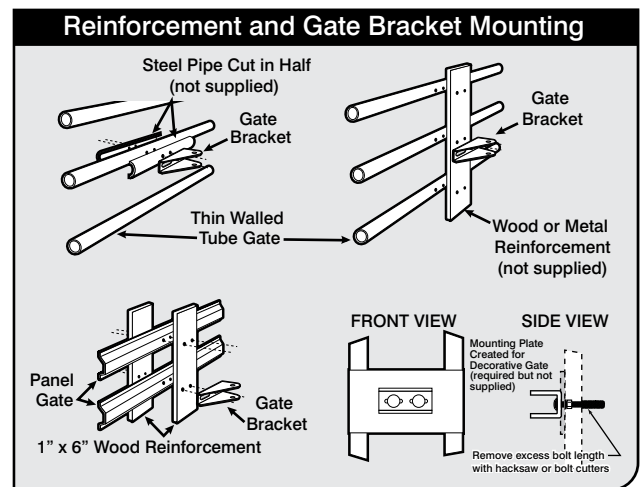

Recommended reinforcement and gate bracket mounting examples.

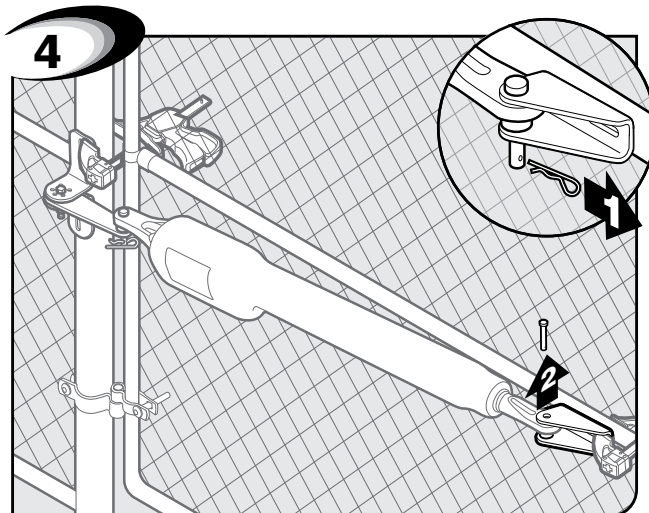

Remove clevis pin from the gate bracket and support loose opener.

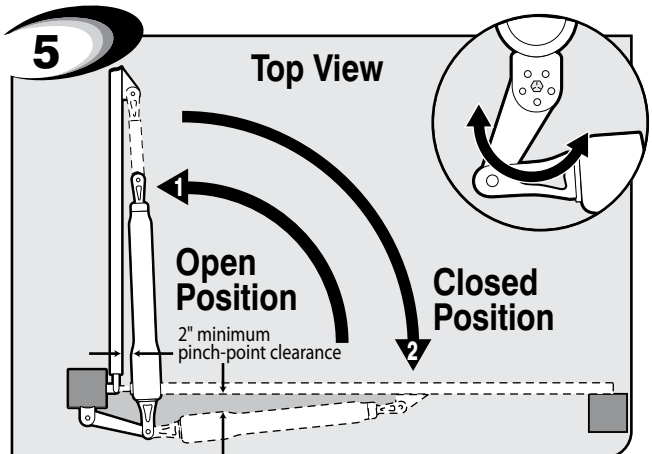

Swing gate to OPEN position. Check clearance/binding by inspecting the alignment. Secure post pivot bracket to post bracket when clearance is OK in both open and closed positions. **TIP:** Turning the pivot bracket over gives more hole alignment options for the post pivot bracket assembly.



Push-to-Open Installation

Mounting Push-to-Open Opener to Gate

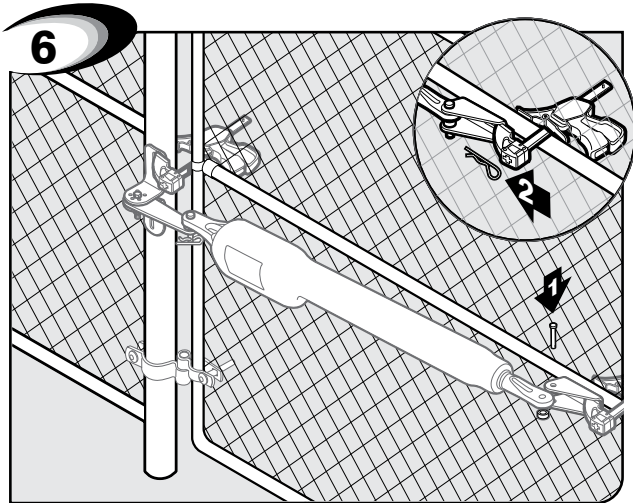

CLOSE gate and re-attach opener with clevis pin. Check for level. Clamp securely.

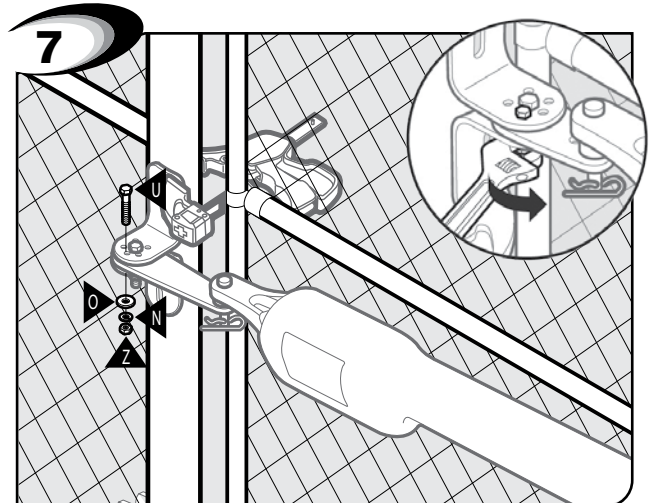

Secure post pivot bracket to post bracket when clearance is OK (Step 5) in both open and closed positions.

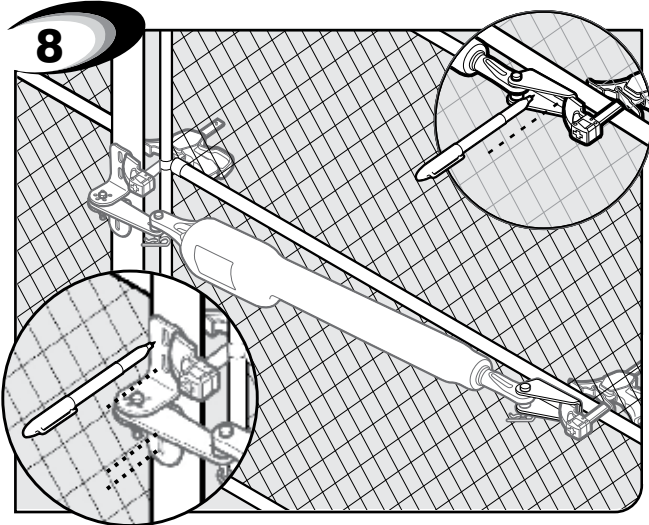

Mark middle of post bracket slots on fence post. Mark middle of gate bracket slots on gate cross support.

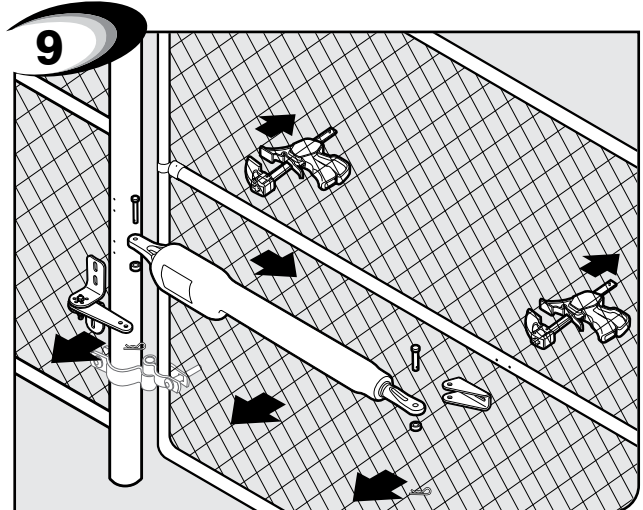

Remove clamps, post, gate brackets, and opener. Then use a hammer and center punch to mark hole positions.

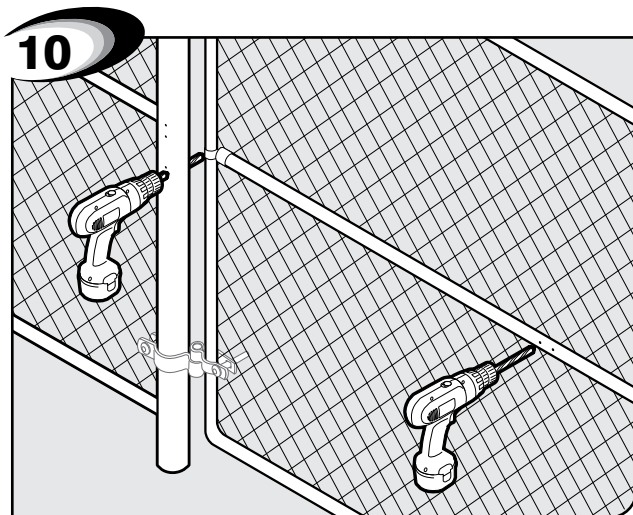

Drill holes completely through gate post and gate cross support.

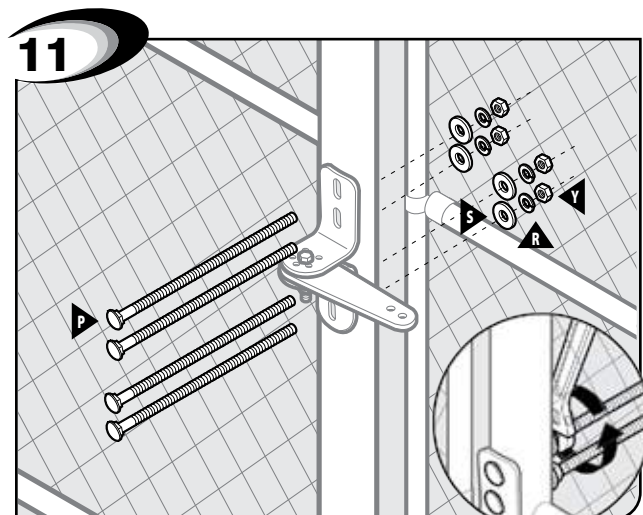

Attach post bracket assembly to fence post. **NOTE:** Must be through bolted.

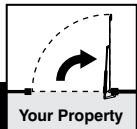

Push-to-Open Installation

Mounting Push-to-Open Opener to Gate

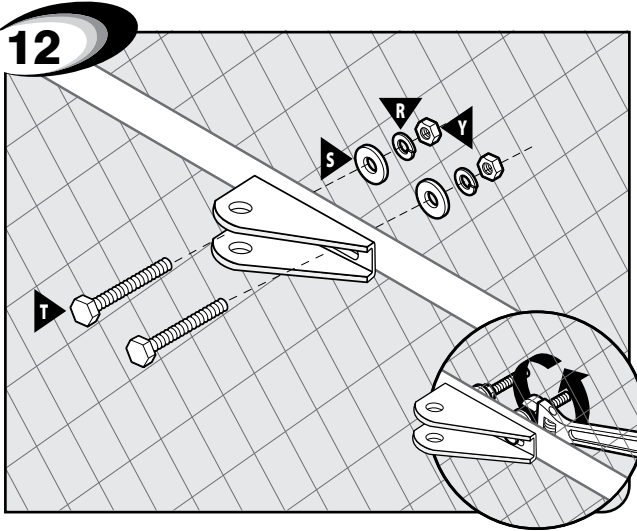

Attach gate bracket assembly to gate cross support.

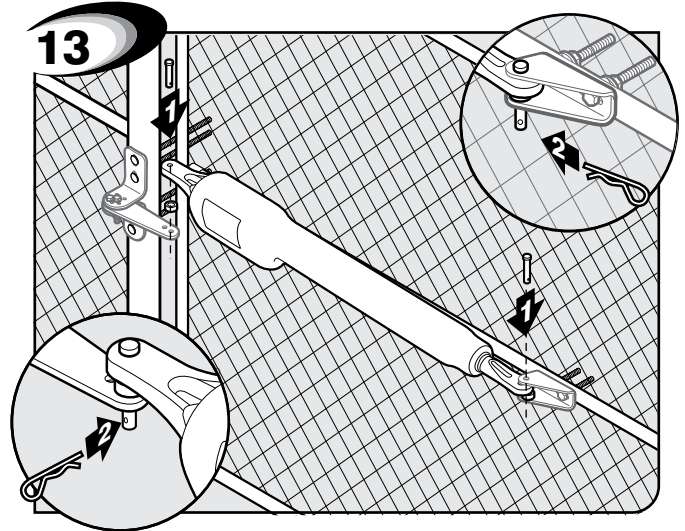

Attach and secure opener assembly to brackets.

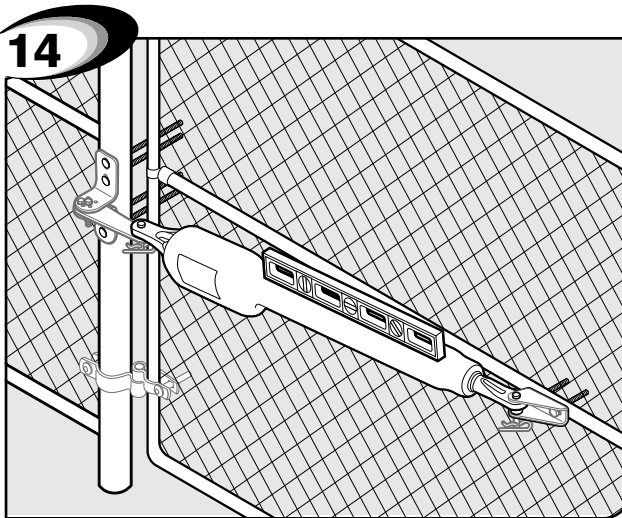

Check for level. Adjust post bracket if necessary.

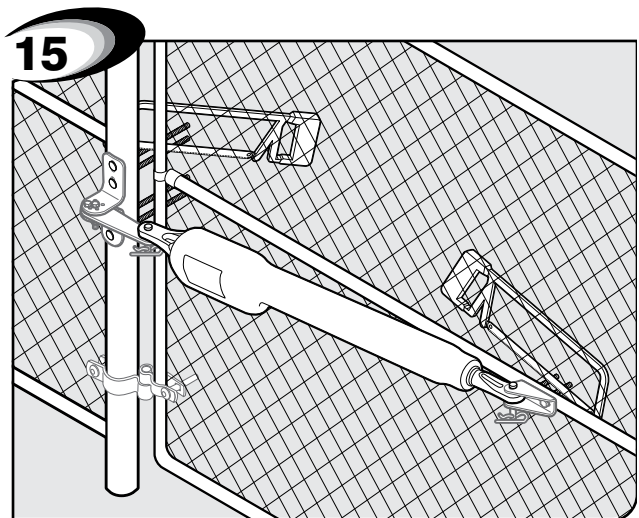

Remove bolt excess length on post and gate bracket with hacksaw.

Closed Position Stop Plate Installation

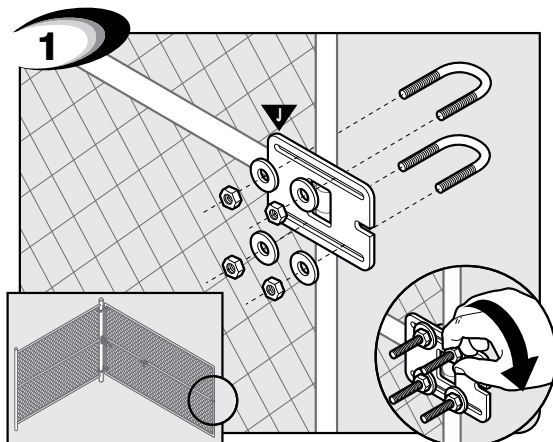

Fully open gate. Attach gate stop with one of the following:
• U-bolts—tube and chain link gates (Not included)
• Wood/lag screws—flat aluminum/wood supports (Not included).
Do not tighten.

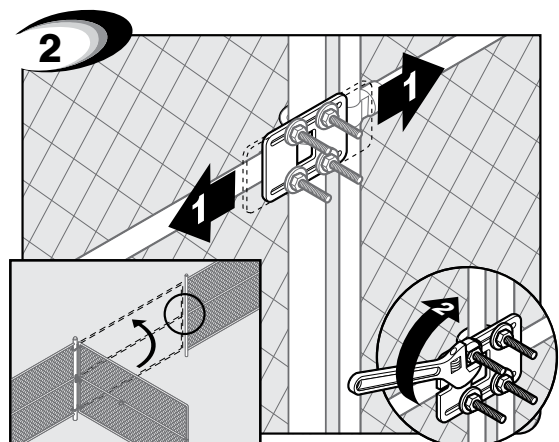

Position gate stop with gate CLOSED to fence post. Tighten fasteners. Cut off excess bolt length.

Control Box Installation

Control Box Installation

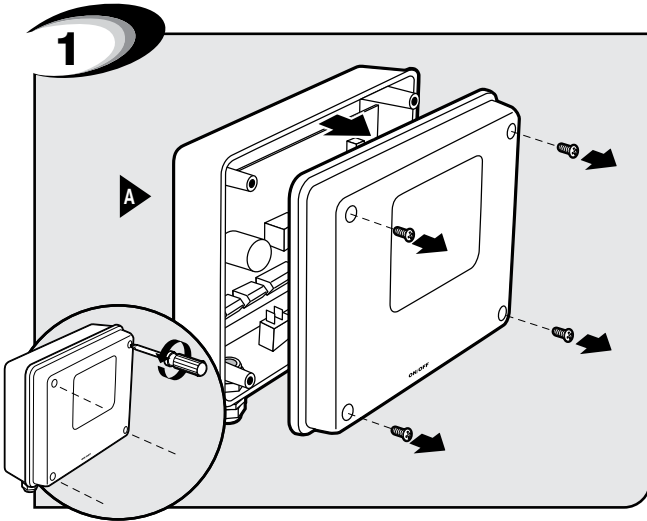

Remove control box cover.

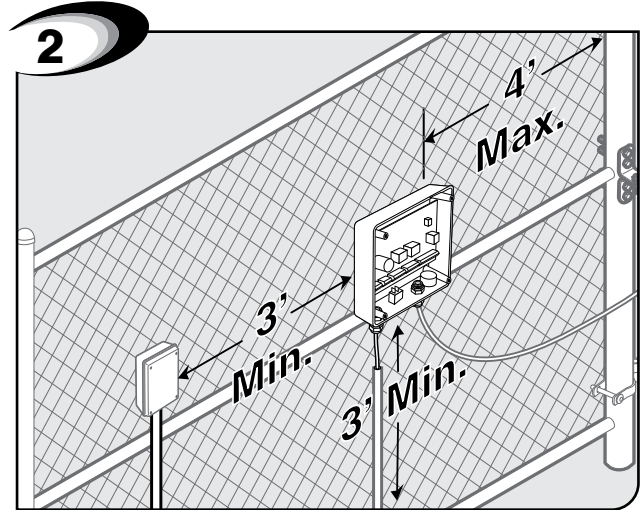

Locate control box mounting area. **IMPORTANT:** Be sure to mount box at least 3 feet from AC power and 3 feet off the ground.

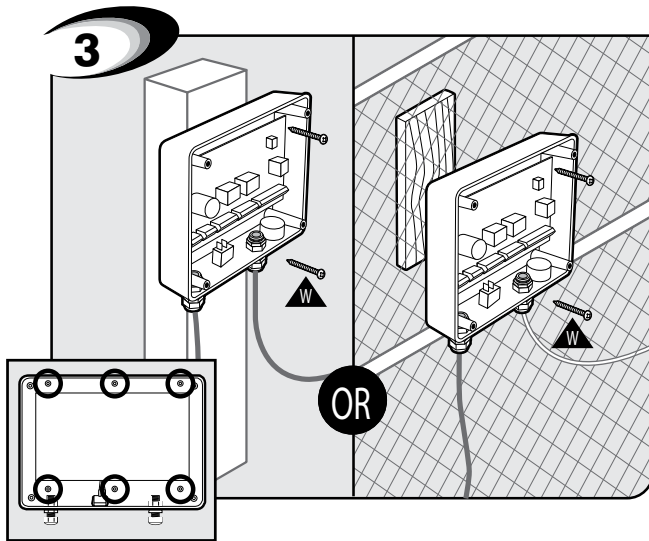

Mount control box to post or fence using screws.

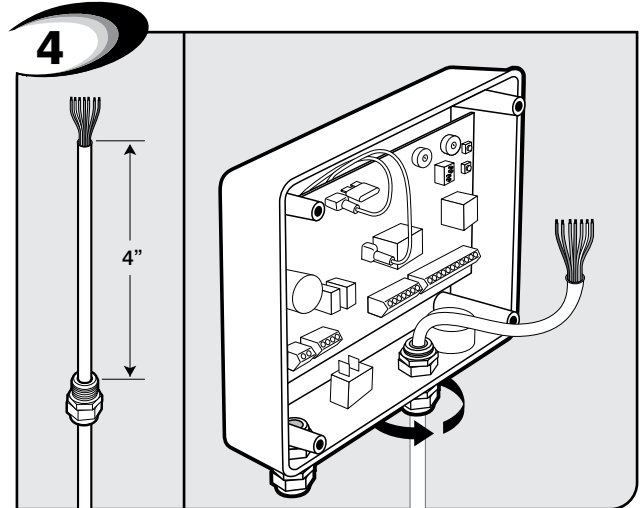

Feed opener cable 4" into box through the strain relief. Tighten strain relief nut to secure cable.

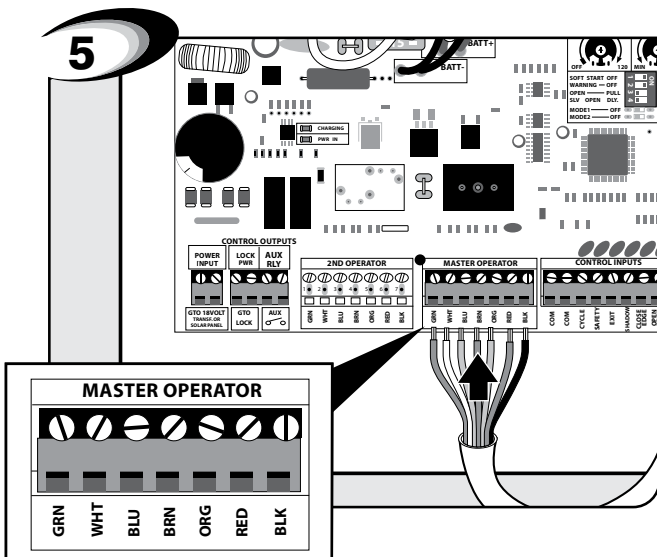

Insert 7 wires into corresponding color terminals.

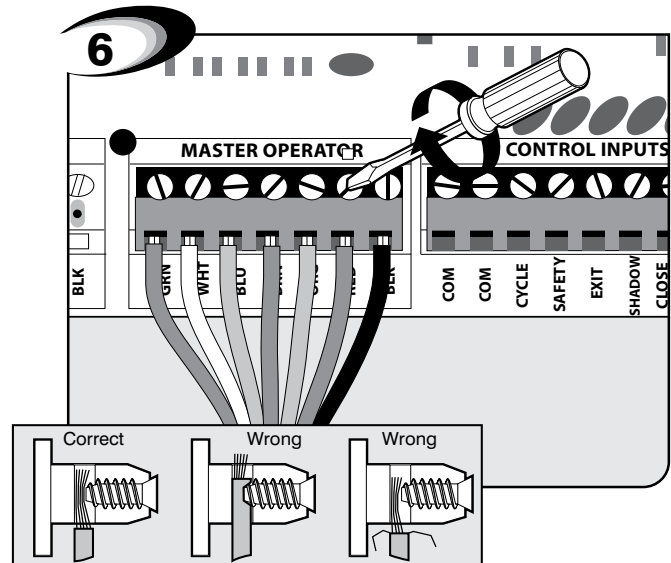

Secure wires in terminals.

Control Box Installation

Receiver Installation

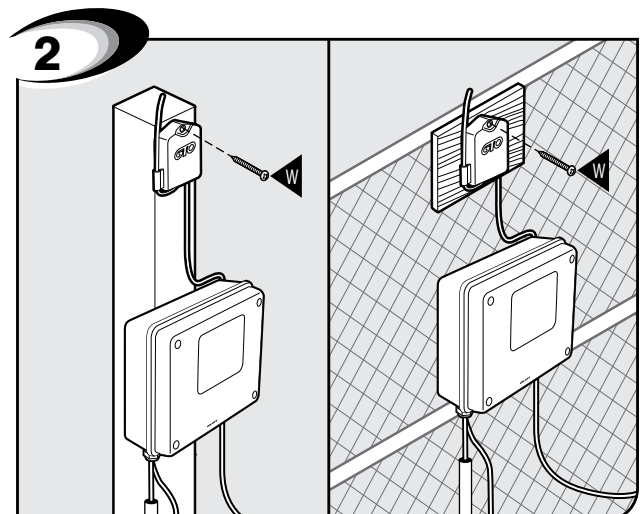
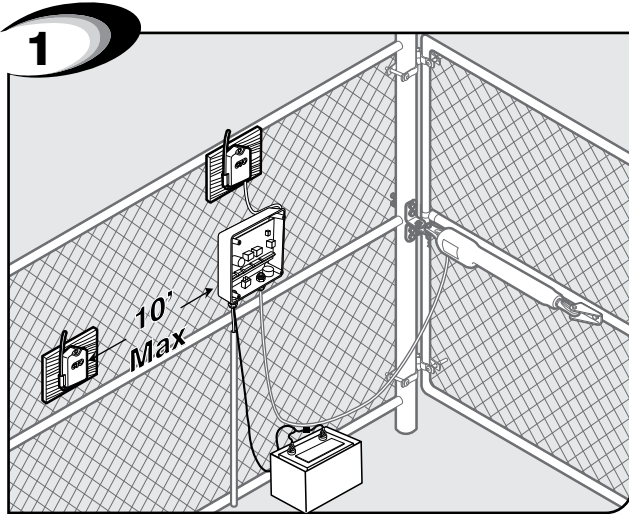

Use the transmitter to check the range of the receiver **before permanently mounting it.**

Consider the following when mounting the receiver:

- Standard receiver cable length is 10 feet (receivers with a longer cable are available as special order items; *call the GTO Sales Department*). NEVER splice receiver cable!
- **Run the cable through PVC conduit to protect it from damage.**
- DO NOT run cable through metal conduit because the receiver signal range will be decreased.
- DO NOT run cable through conduit containing AC wire.
- DO NOT place receiver within 3 feet of AC power.
- DO NOT coil excess cable or store it in the control box.
- **Do not mount upside down.**
- The receiver range can vary from 50 to 100 feet depending upon weather, topography, and external interference.

FCC Regulation

This device complies with FCC rules Part 15.
Operation is subject to the following conditions:
1. This device may not cause harmful interference.
2. This device must accept an interference that may cause undesired operation.

Transmitter distance may vary due to circumstances beyond our control. **NOTE: The manufacturer is not responsible for any radio or TV interference caused by unauthorized modifications to this equipment. Such modifications could void the user's authority to operate the equipment.**

Control Box Installation

Connecting the Battery

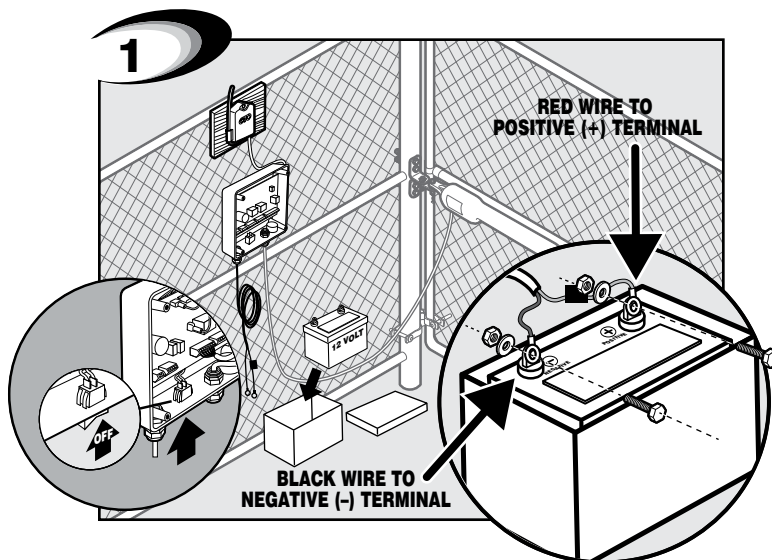

Turn control box OFF. Place the 12 Volt Lawn Tractor or Automotive battery and weatherproof battery box within 6 feet of the control box. Attach the battery harness wires from the control box to the battery terminals using bolts, washers and nuts. Be sure to attach the RED wire to the POSITIVE terminal and the BLACK wire to the NEGATIVE terminal.

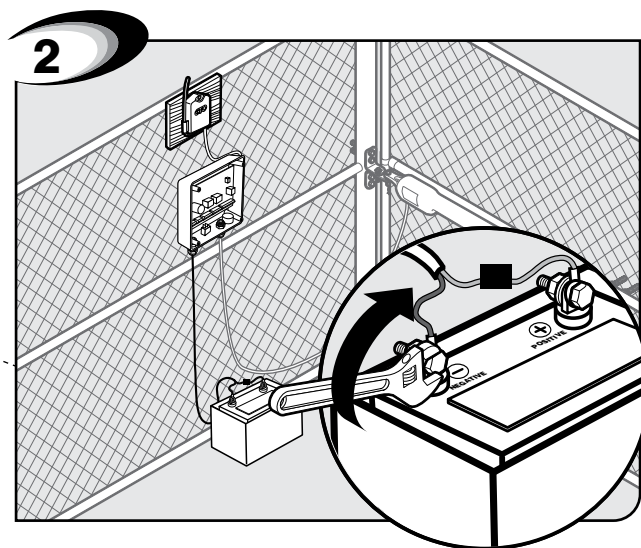

Tighten the bolts, washers, and nuts and place the cover on the weatherproof box. **IMPORTANT:** Do not connect the transformer or solar panel directly to the battery. This will cause the system to fail.

Transformer Wiring Installation

IF USING OPTIONAL SOLAR PANEL CHARGER INSTEAD OF TRANSFORMER TO CHARGE THE BATTERY, GO TO PAGE 23.

IMPORTANT: Do NOT connect both solar panel and transformer.

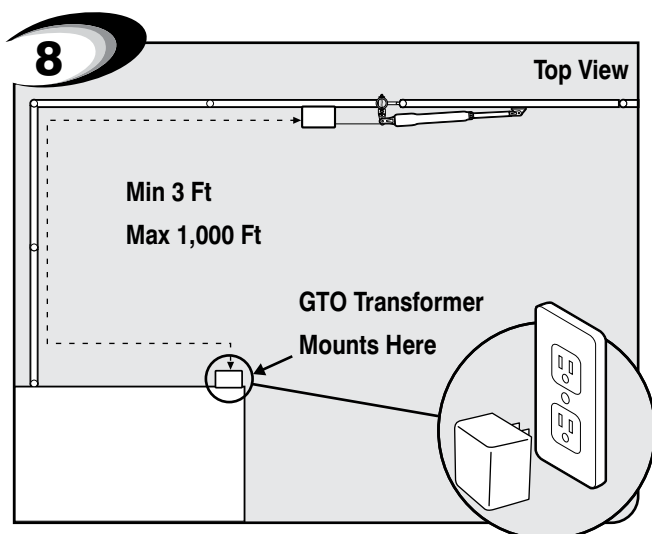

Locate power outlet and identify wire path to control box.
NOTE: If OUTLET is OUTSIDE use weatherproof cover.

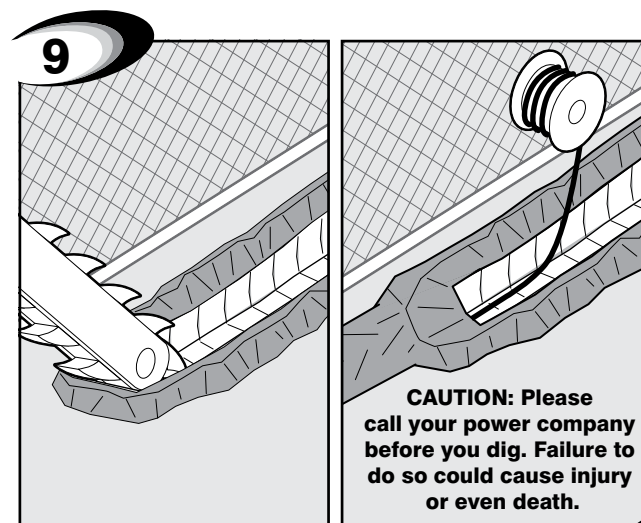

Dig trench and lay wire from AC power source to control box. Use only 16 gauge multi-stranded, low voltage, direct burial wire (RB509). *NOTE: DO NOT use telephone wire or solid core wire. NEVER splice wires together. We recommend running wire in PVC conduit.*

Control Box Installation

Transformer Wiring Installation

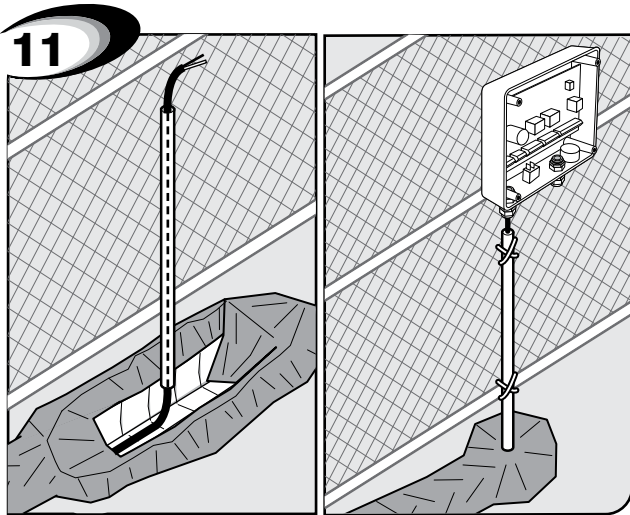

Use PVC conduit from ground up to control box.

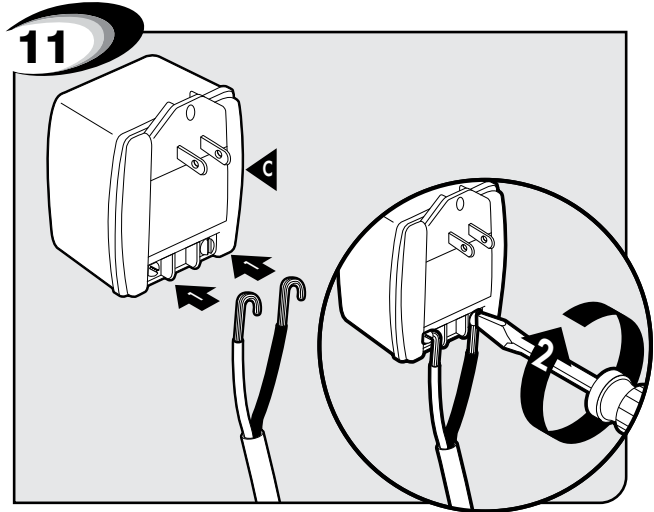

Strip 1/2" off 2 wires and twist ends. Attach wires to transformer screw terminals.

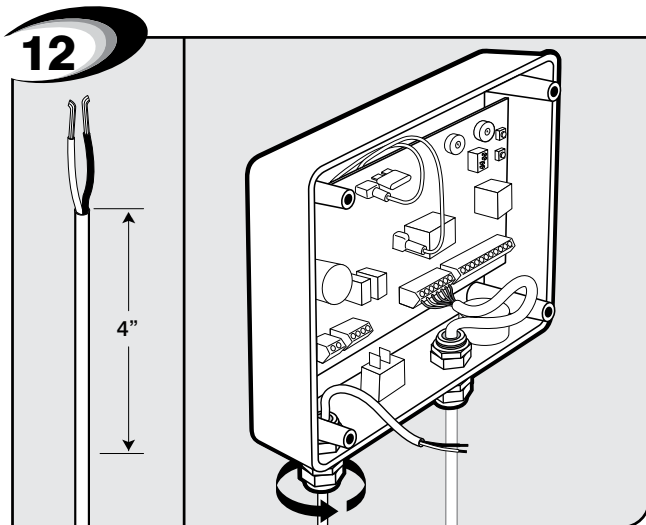

Feed 4" of low voltage wire through strain relief into box with battery wire harness and tighten strain relief to secure wires.

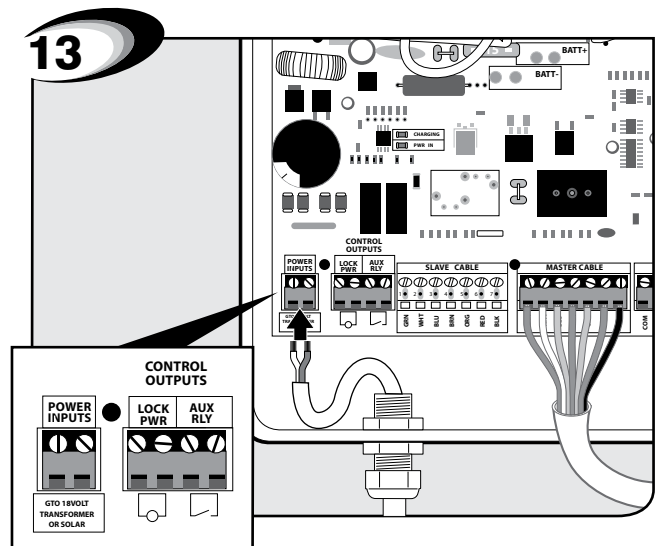

Insert one wire into each 18VAC terminal. Colors do not matter.

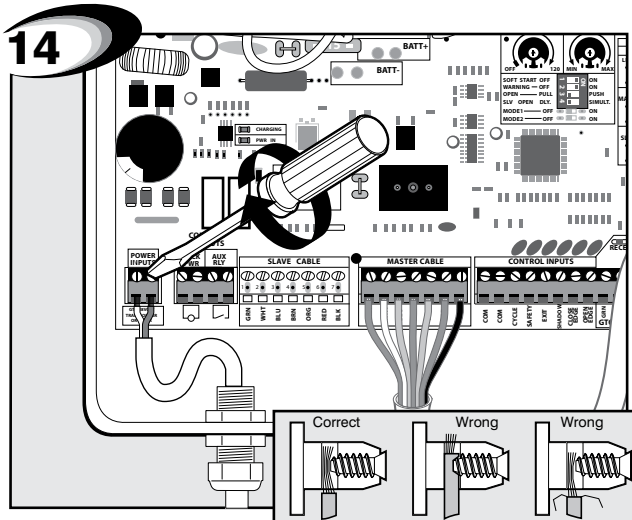

Secure with terminal screws.

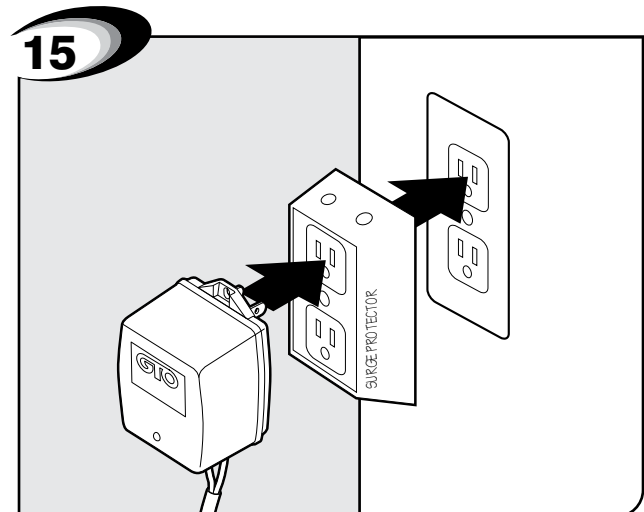

Plug in transformer to power outlet. (Use of a surge protector is highly recommended. **If outdoors use weatherproof box.**)

Solar Panel Installation

(Optional)

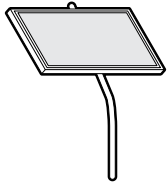

The table and map illustrate the maximum number of gate cycles to expect per day in a particular area when using from 5 to 30 watts of solar charging power. (see accessory pages in back of this book). The figures shown are for winter

(minimum sunlight) and do not account for the use of any accessory items. Accessories connected to your system will draw additional power from the battery.

NOTE: A minimum of 5 watts of solar charging power is required for Mighty Mule 500 single gate systems, with a maximum of 30 watts. Consult Solar Panel Installation Instructions for further information.

Winter Ratings	Zone 1	Zone 2	Zone 3
12 v single gate (5 watts) solar charger	4	8	13
12 v single gate (10 watts) solar charger	8	16	26
12 v single gate (15 watts) solar charger	11	20	30
12 v single gate (20 watts) solar charger	14	28	38
12 v single gate (25 watts) solar charger	17	36	46
12 v single gate (30 watts) solar charger	20	44	54

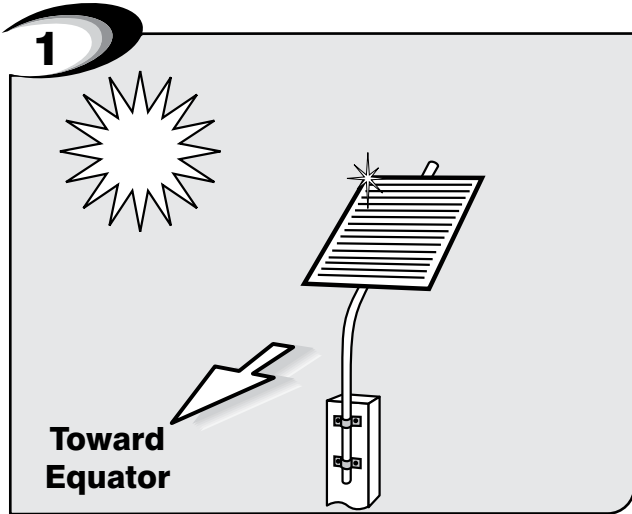
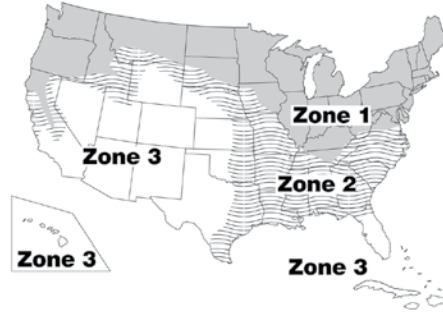

The solar panel must be positioned facing the path of the sun and in an open area away from shade. It should receive at least 8 hours of direct sunlight for a full charge.

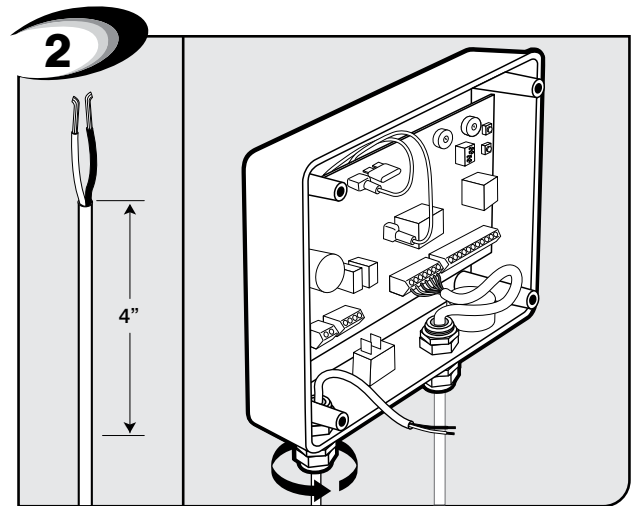

Feed cable 10" into box.

Solar Panel Installation

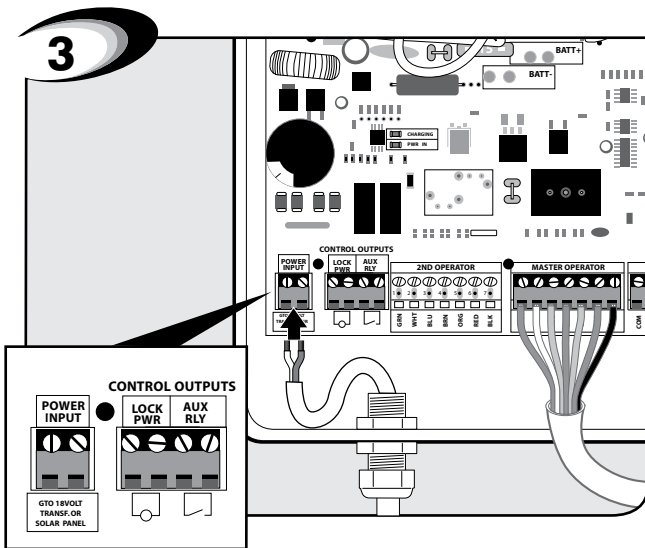

Insert **RED** and **BLACK** wires into the **POWER INPUT** terminals. **NOTE:** Colors do not matter in this terminal.

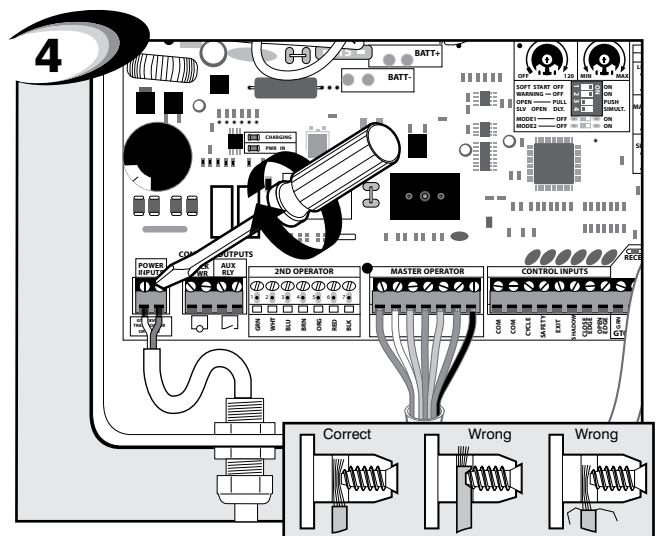

Secure with terminal screws.

Multiple Panel Installations

NOTE: All connections should be weatherproofed using weatherproof splice kits available at hardware and electrical supply stores.

Solar Panels connect in **PARALLEL**

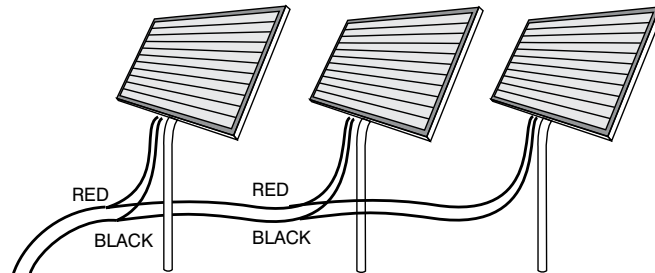

attach wires to **POWER INPUT** terminals marked "GTO 18VOLT TRANSF. OR SOLAR PANEL" on the control board.
(wire color does not matter on this terminal connection)

Control Box Settings

DIP Switches

IMPORTANT: Before making any changes to dip switches turn control box off!

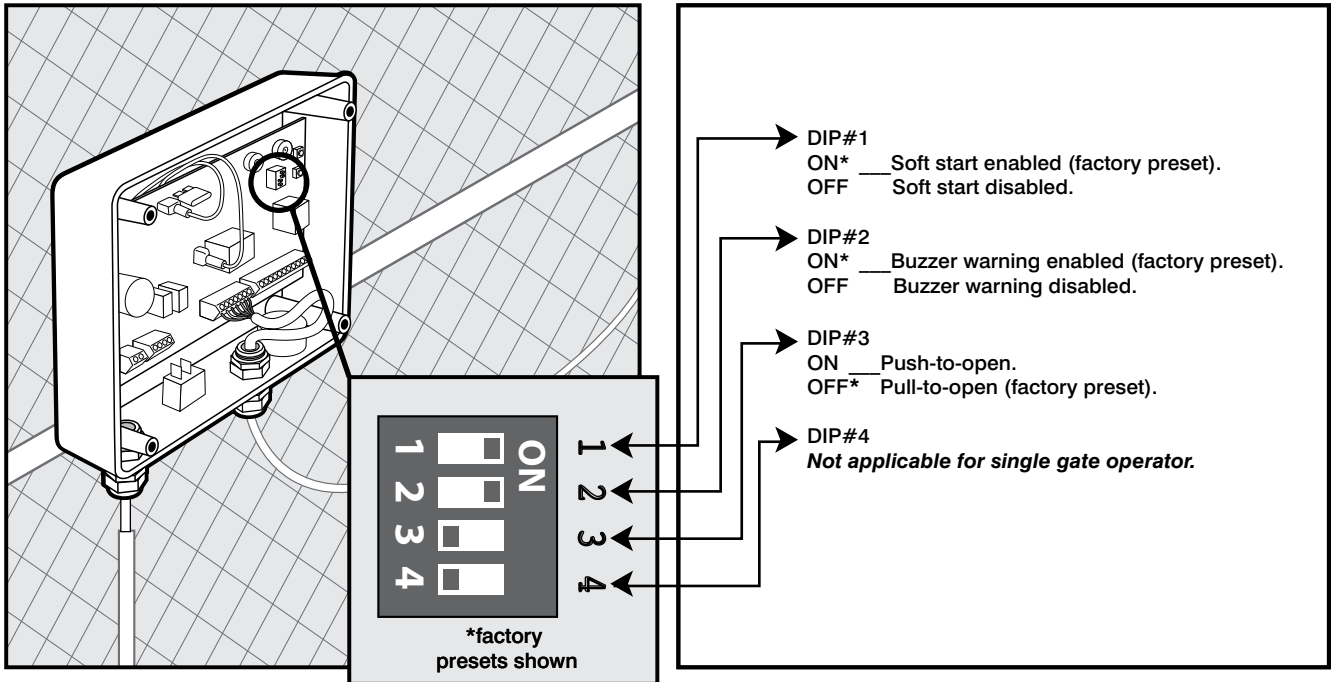

DIP Switch #1 - Soft Start/Stop

The soft start/stop feature slowly starts the gate as it begins to open or close and slows the gate as it comes to the opened or closed position. This saves wear and tear on the gate and gate opener system.

DIP Switch #2 - Warning Buzzer

The warning buzzer alerts you when the gate opener is beginning to either open or close the gate. It sounds for the first 2 seconds in each direction. It also sounds a warning when the gate obstructs two times in one cycle. Switching this to OFF only disables the open and close warning not the obstruction warning.

DIP Switch #3 - Push/Pull-to-Open

If your gate opens into the property the DIP Switch is set to the OFF position (factory setting). If your gate opens out from the property the DIP Switch must be set to the ON position. NOTE: if you have a Push-to-Open gate application you will need a Push-to-Open bracket (see Push-to-Open Instructions on page 16).

DIP Switch #4 - Not applicable for single gate operators.

Control Box Settings

Setting Pull-to-Open (Closed) Gate Limit (for push-to-open go to pg. 27)

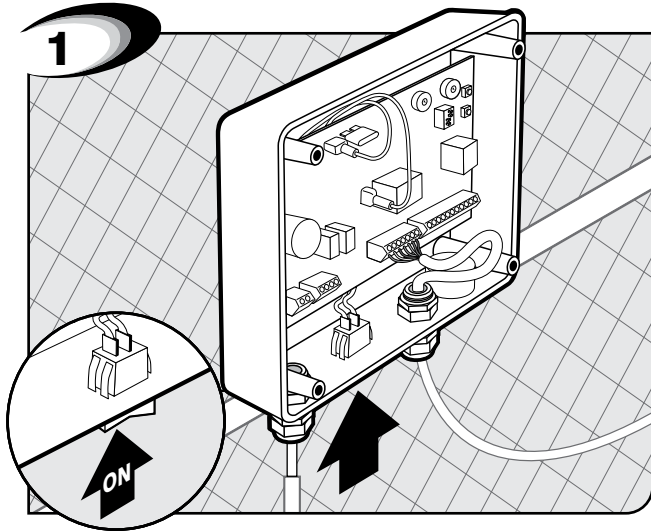

With gate in OPEN position, turn control box power ON.

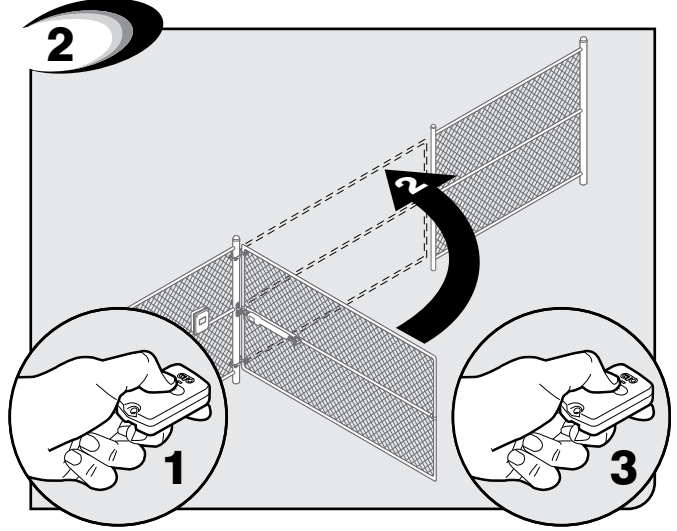

Press button on transmitter; gate should start closing. Press button on transmitter again when gate is in desired CLOSED position. **NOTE:** If your gate stops and reverses before it fully closes, you may need to increase the stall force. (See page 28)

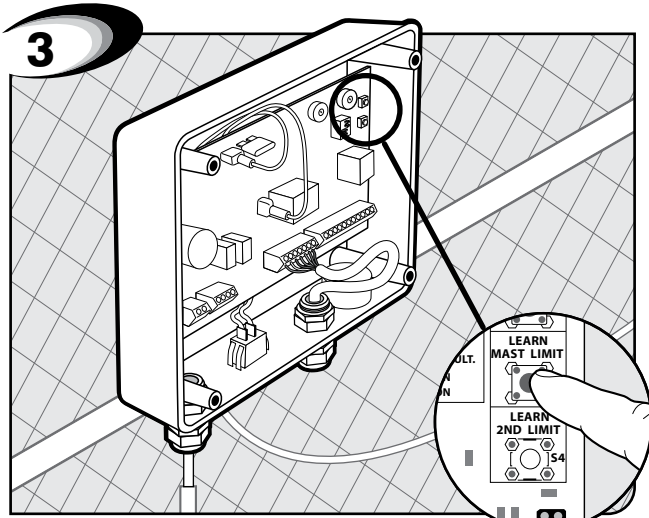

Press and hold the "LEARN MAST LIMIT" button for 5 seconds, or until the alarm sounds.

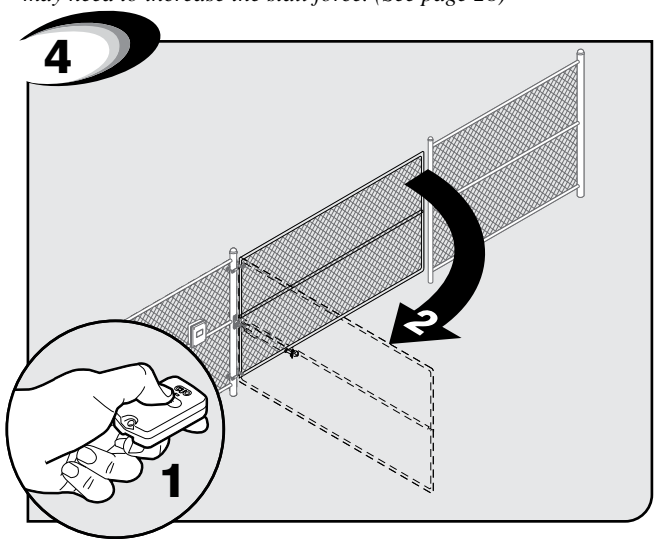

Press button on transmitter to fully open gate. Closed limit is set upon reaching fully open position. Test and, if needed, reset and start over.

Resetting Closed Gate Limit

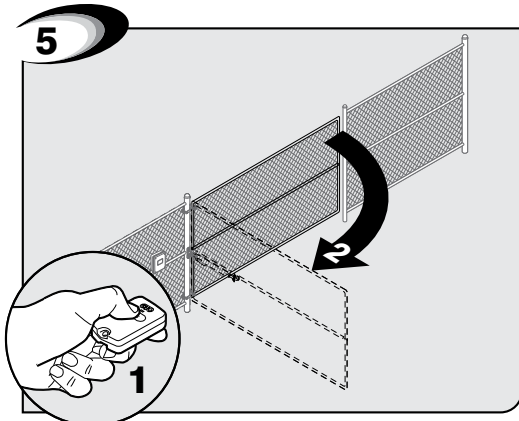

Press button on opener remote to open gate.

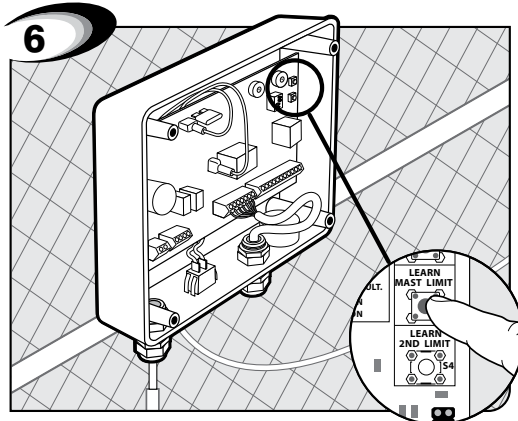

Press and hold the "LEARN MAST LIMIT" button for 10 seconds, or until the alarm sounds to clear. Go back to the setting closed limit steps on the top of this page.

Control Box Settings

Setting Push-to-Open (Open) Gate Limit (for pull-to-open go to pg. 26)

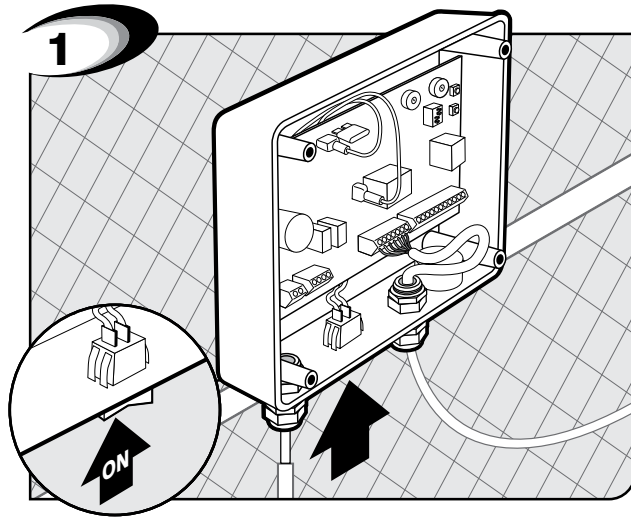

With gate in CLOSED position, turn control box power switch to ON.

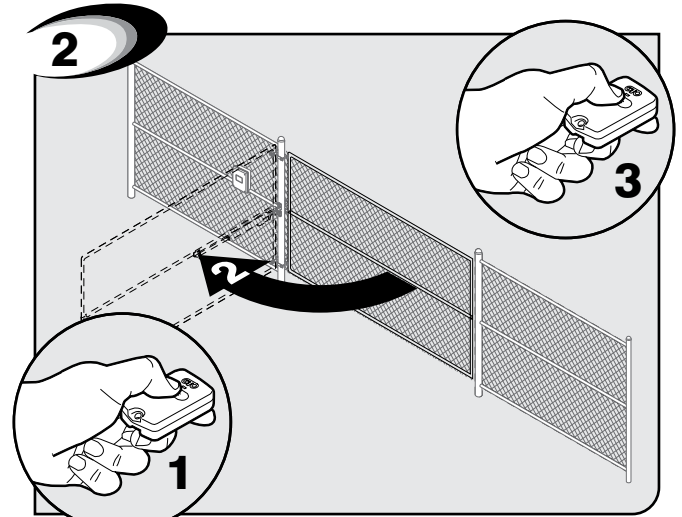

Press button on transmitter; gate should start opening. Press button on transmitter again when gate is in desired OPEN position. **NOTE:** If your gate stops and reverses before it fully opens, you may need to increase the stall force. (See page 28)

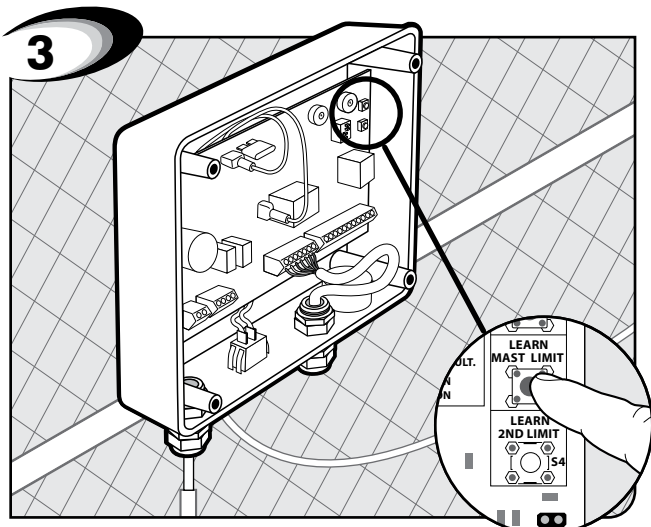

Press and hold the "LEARN MAST LIMIT" button for 5 seconds, or until the alarm sounds.

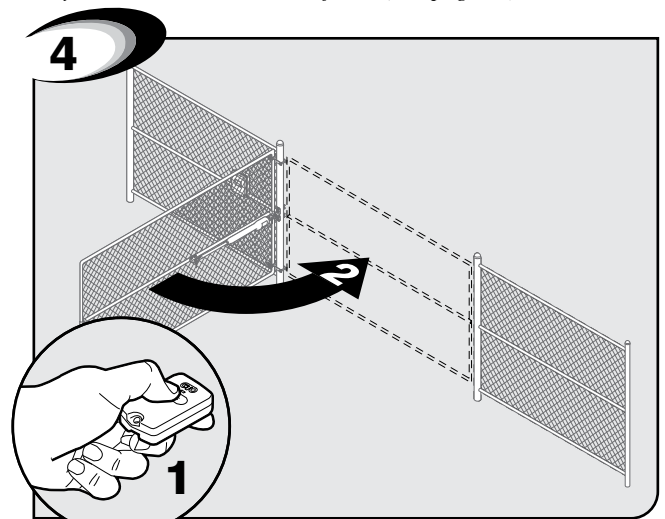

Press button on transmitter to fully close gate. Open limit is set upon reaching the fully closed position. Test and, if needed reset and start over.

Resetting Open Gate Limit

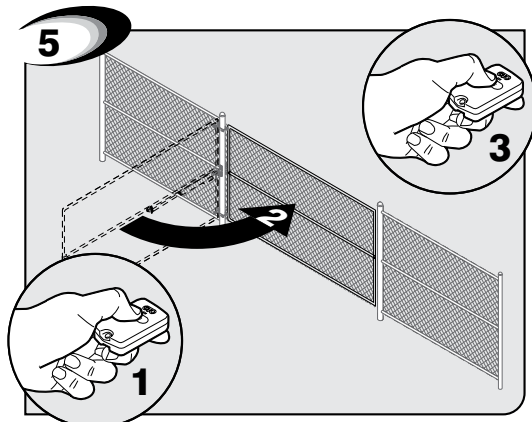

Press button on opener remote to close gate.

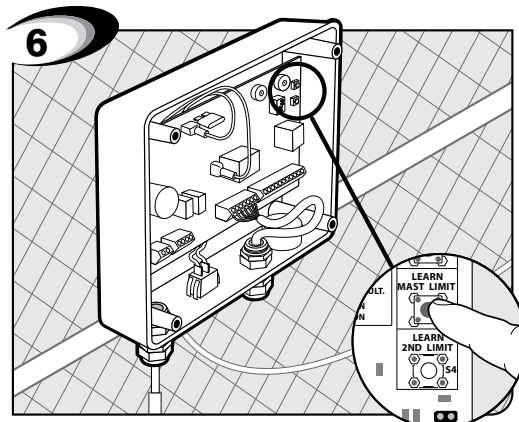

Hold the "LEARN MAST LIMIT" button for 10 seconds, or until the alarm sounds to clear. Go back to setting open gate limit step 1 at the top of this page.

Control Box Settings

Setting Obstruction Stall Force & Auto Close Time

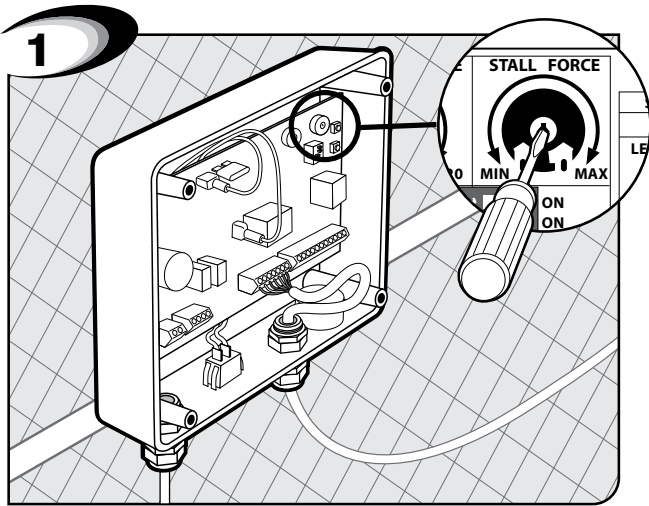

Turn the "STALL FORCE" arrow in the center of the potentiometer with small flat head screwdriver. Adjust the sensitivity from the MINIMUM position up to the point where the gate operates without obstructing from its own weight or the wind conditions in your area.

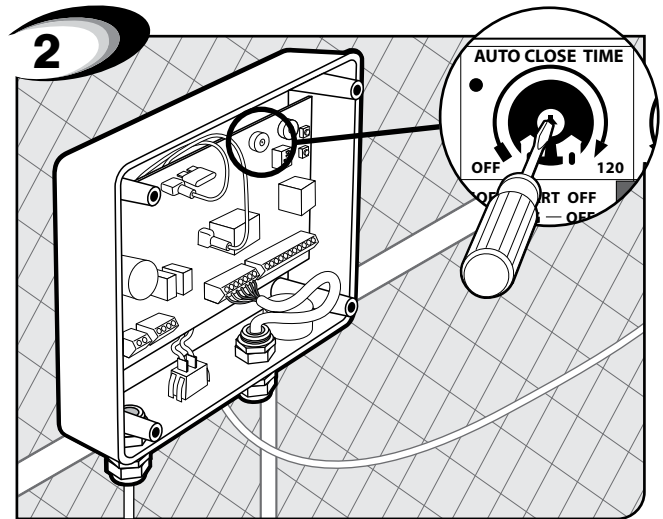

Turn the "AUTO CLOSE TIME" arrow in the center of the potentiometer with small flat head screwdriver to determine how long the gate will remain open before it automatically closes. The limits are OFF and 3 - 120 seconds. The factory setting is OFF.

IMPORTANT: For safety reasons the obstructions setting or Stall Force on the Mighty Mule® control board comes from the factory set at MIN (minimum). In many installations this setting will need to be adjusted to overcome the weight and size of the gates.

ALWAYS KEEP SAFETY AT THE TOP OF YOUR LIST WHEN ADJUSTING OR SERVICING YOUR AUTOMATIC GATE OPENER

Setting Personal Transmitter Code

All GTO transmitters are set to a standard code at the factory and are ready to operate your gate opener. For your safety and security, however, we **strongly recommend** that you replace the factory setting with your own personal code. Follow the directions below:

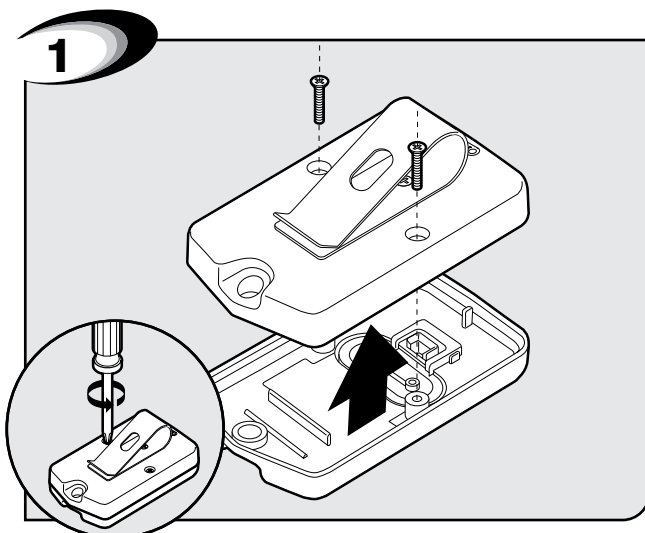

Remove back cover of the opener remote.

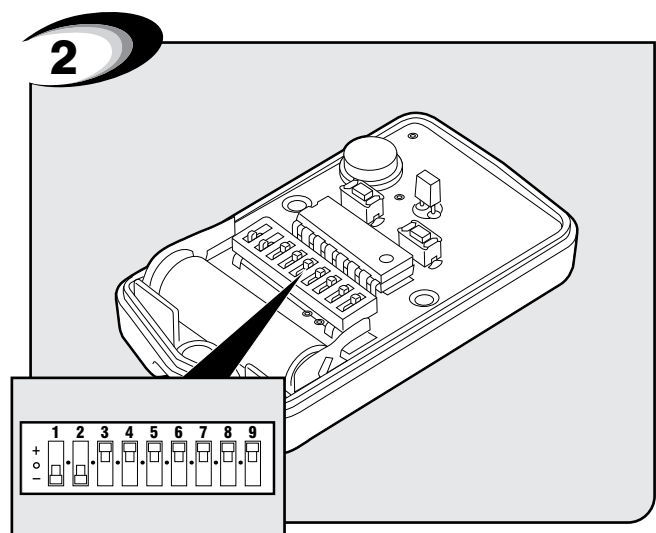

Flip opener remote over. Use small screwdriver to move switches to random positions. If you have more than one transmitter, now is a good time to set them all with the same code.

Control Box Settings

Setting Personal Transmitter Code

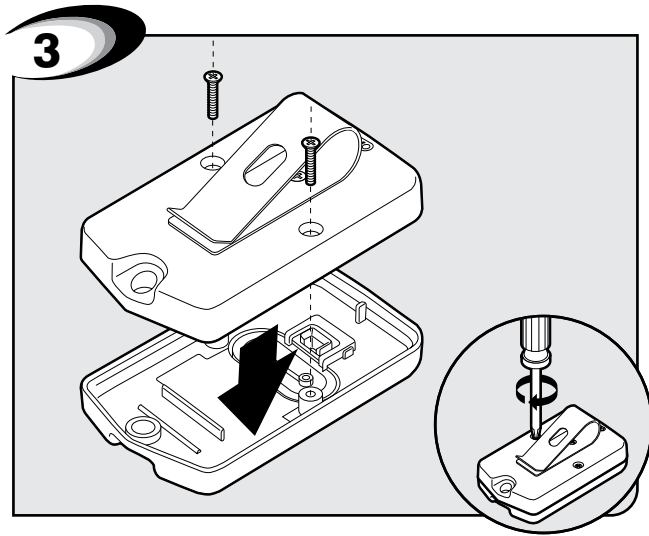

Replace and secure back cover of the opener remote.

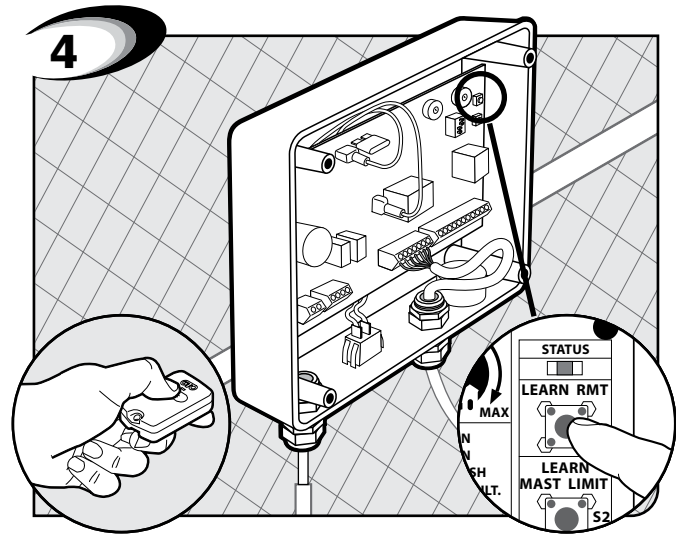

Go to control box. Press and hold the remote and “LEARN RMT” buttons simultaneously for 5 seconds or until the alarm sounds.

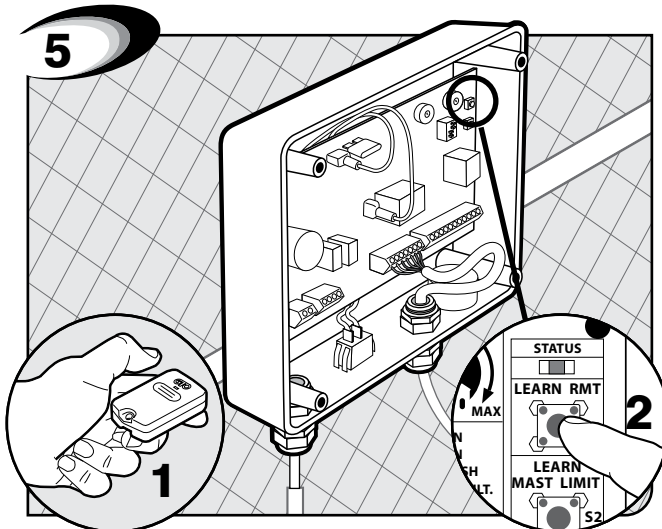

Release the remote button, then release the “LEARN RMT” button. The new code is now programmed.

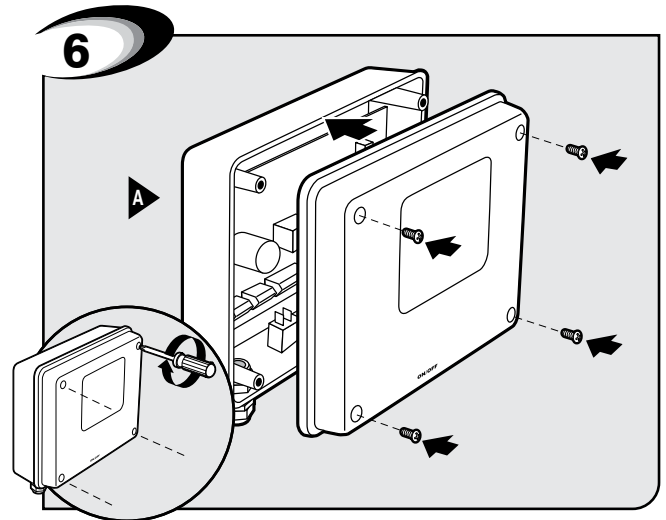

Replace control box cover.

FCC Regulation

This device complies with FCC rules Part 15. Operation is subject to the following conditions:
1. This device may not cause harmful interference.
2. This device must accept an interference that may cause undesired operation.

Transmitter distance may vary due to circumstances beyond our control. **NOTE: The manufacturer is not responsible for any radio or TV interference caused by unauthorized modifications to this equipment. Such modifications could void the user's authority to operate the equipment.**

Connecting Additional Devices

Before You Begin

Although GTO strongly recommends the use of additional safety devices, we do not endorse any specific brand names. Only use products that are certified and listed to be in compliance with any applicable UL safety standards (Underwriters Laboratories) and national and regional safety codes.

Call GTO Sales at 1-800-543-4283 for information on compatible products for your specific application

The Mighty Mule 600 will ONLY accept accessory devices with normally open dry contact output.

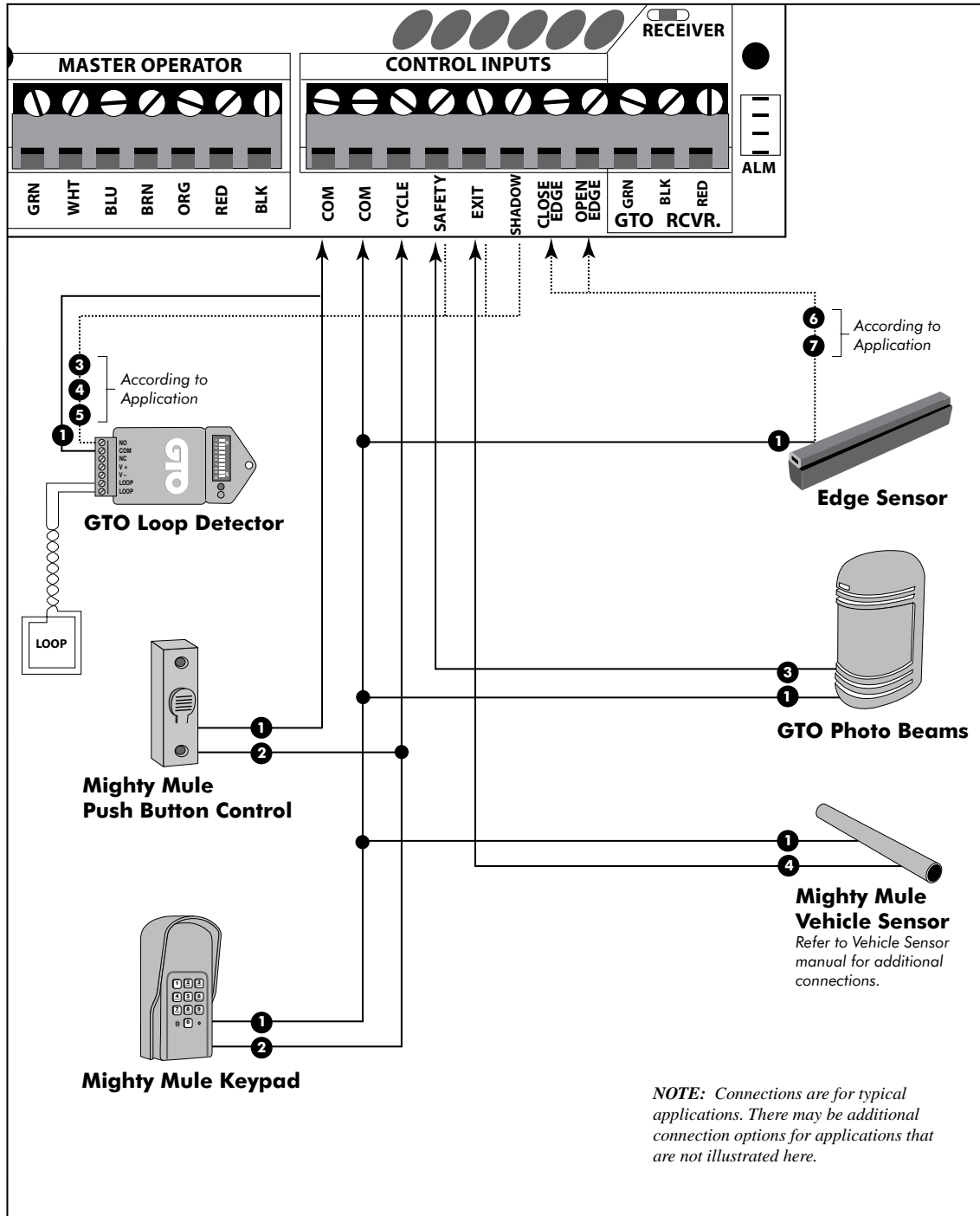

Connecting Additional Devices

Input Connections

NOTE:

- All control inputs are dry-contact, normally open, inputs. DO NOT apply external voltage sources to these inputs.
- All inputs are connected with respect to **COMMON** terminal.
- The status light will blink once when its corresponding input is activated.

- 1 COM:** Circuit common (reference for all logic input)
- Two (2) terminals to provide extra common connection point.

- 2 CYCLE:** (Typically for use with doorbell button or hardwired key pad)
- Each activation at this input will cycle the operation as follows:
... OPEN STOP CLOSE STOP OPEN ...

- 3 SAFETY:** (Typically for use with photo beam device, loop detector or other non-contact sensors)
- Activation of this input while the gate is closing will cause the gate to stop and return to the opened position.
 - Activation of this input while the gate is opening has no effect (gate will continue to open).
 - Activation of this input while gate is idle will prevent gate from closing.

- 4 EXIT:** (Typically for use with exit loop or wand)
- Activation of this input will open the gate if it's not already at the open position
 - Activation of this input while at open limit will restart the auto close time (if enabled).

- 5 SHADOW:** (Typically for use with loop detector device)
- This input is only monitored when the gate is at the fully open position. At any other position, activation of this input has no effect on gate operation.
 - Activation of this input while gate at the fully open position will prevent gate from closing.

- 6 CLOSE EDGE:** (Typically for use with safety edge device)
- Activation of this input while the gate is closing will cause the gate to stop and reverse direction for approximately 2 seconds.
 - Activation of this input while the gate is opening has no effect (gate will continue to open).
 - Activation of this input while gate is idle will prevent gate from closing.

- 7 OPEN EDGE:** (Typically for use with safety edge device)
- Activation of this input while the gate is opening will cause the gate to stop and reverse direction for approximately 2 seconds.
 - Activation of this input while the gate is closing has no effect (gate will continue to close).
 - Activation of this input while gate is idle will prevent gate from opening.

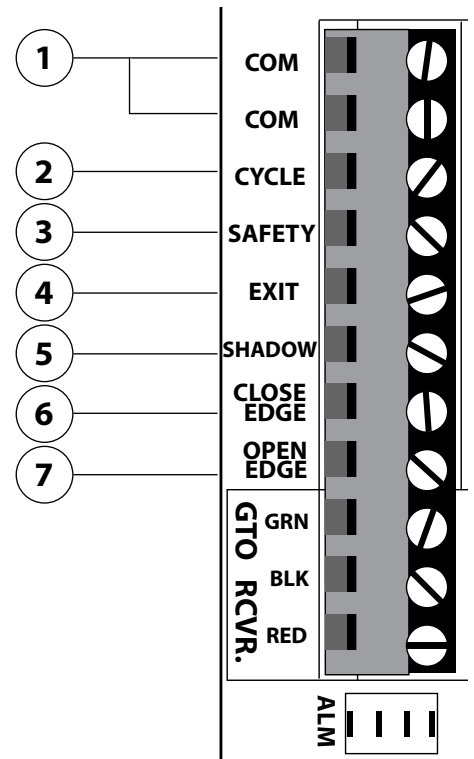

Connecting Additional Devices

Connecting GTO Automatic Lock

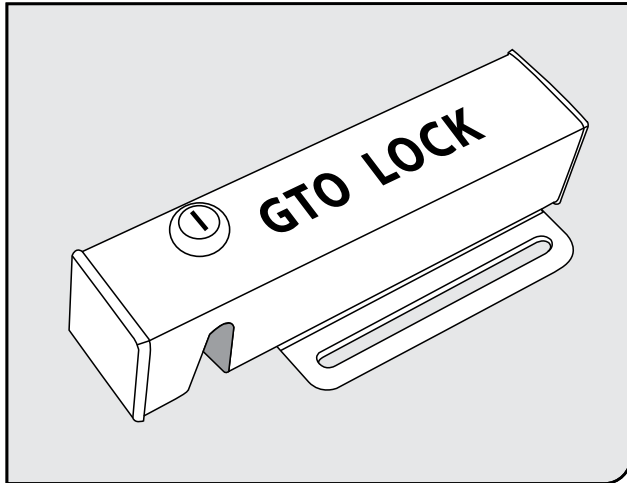

GTO Automatic Gate Lock:

LOCK PWR terminals are use exclusively with the GTO Automatic Gate Lock (FM143). Connecting other devices to these terminals may cause incorrect operation and void your warranty. You do not use the lock board with this control board.

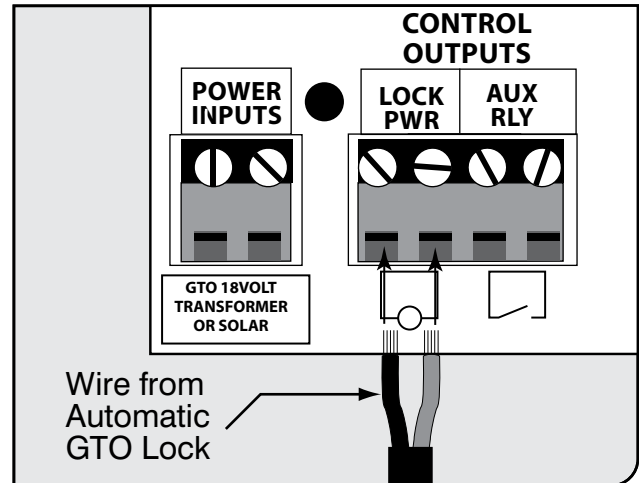

GTO Lock Connection:

Connect the red and black leads from the lock to the GTO LOCK terminal on the control board.

Connecting Other Auxiliary Devices (Mag Locks, Sirens, Lights. . .}

- **AUX RLY** terminals are normally open, dry-contact (no voltage) relay output.
- **AUX RLY** terminals are ON (shorted) whenever the gate is moving and OFF (opened) otherwise.
- **AUX RLY** terminals have a maximum rating of 24Vdc, 1 Amp.

Maintenance & Troubleshooting

Maintenance Tips

- On all gates weighing 250 lb. or more, routinely grease the ball bearing hinges at least 4 times a year; more frequently if the gates are near a coastal area.
- Keeping a few mothballs in the control box will discourage insects from entering it and damaging the control board.
- Clean the push-pull tube with a soft, dry cloth and apply silicone spray to it at least once per month.

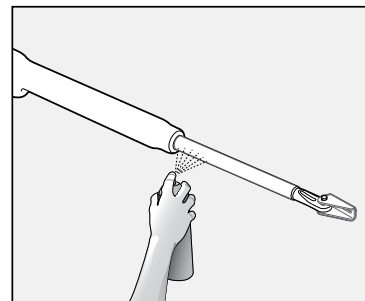

Troubleshooting Guide

If your gate opener does not function properly after it is installed, use this guide before calling the GTO Service Department.

Additional information can be found online 24 hours 7 days a week at the GTO Tech Wizard (support.gtoinc.com/Support/TroubleShooter.aspx)

Audible Feedback

Symptom	Diagnosis	Check:
1 short beep upon activation	Blown Fuse Low or Bad Battery Loose Battery Connection	<ul style="list-style-type: none"> Fuses - control board and battery harness cable Battery Under Load Battery Harness Connections
1 short beep upon power up	Circuit Board Powered Up & Ready	<ul style="list-style-type: none"> Normal Operation
Continuous Uninterrupted Alarm	Circuit Board Senses an Obstruction	<ul style="list-style-type: none"> Path of Gate Gate for Level and Plumb Stall Force Adjustment Disconnect Safety Devices Rev Counter
1 beep with 10 seconds off	Low Battery Condition	<ul style="list-style-type: none"> Fuses - control board and battery harness cable Battery Harness Connections Battery Under Load
1 beep then 2 beeps with 2 seconds off	Master Motor Terminals Shorted	<ul style="list-style-type: none"> Connections to Master Inputs Master Arm Power Cable Motor Circuit Board
1 beep with 2 seconds off	Master Arm Limit Switch Error	<ul style="list-style-type: none"> Connections to Master Inputs Master Arm Power Cable Master Input ORG & GRN, BRN & GRN voltage with wires disconnected. 11VDC across each terminal.
3 beeps with 2 seconds off	Master Arm Rev Counter Error	<ul style="list-style-type: none"> Connections to Master Inputs Master Arm Power Cable Rev Counter

Visual Feedback

Symptom	Diagnosis	Check:
Status (clear) 1 blink	Cycle Terminal Shorted	Disconnect the push button, keypad, intercom keypad, or any other accessory wired to this terminal. Try the remote. If the remote works, then the problem is the accessory.
Status (clear) 2 blinks	Safety Terminal Shorted	Disconnect the loop detector, photo beam, or any other accessory wired to this terminal. Try the remote. If the remote works, the problem is the accessory.
Status (clear) 3 blinks	Exit Terminal Shorted	Disconnect exit wand, loop detector, photo beam, Knox box, or any other accessory wired to this terminal. Try remote. If the remote works, the problem is the accessory.
Status (clear) 4 blinks	Shadow Terminal Shorted	Disconnect the loop detector, photo beam, or any other accessory wired to this terminal. Try remote. If the remote works, the problem is the accessory.
Status (clear) 5 blinks	Close Edge Terminal Shorted	Disconnect the edge sensor, photo beam, or any other accessory wired to this terminal. Try the remote. If the remote works, the problem is the accessory.
Status (clear) 6 blink	Open Edge Terminal Shorted	Disconnect edge sensor, photo beam, or any other accessory wired to this terminal. Try the remote. If the remote works, the problem is the accessory.
RF (yellow) Flickers	Receiving 318 MHz RF	Normal operation when remote or wireless keypad is used.
RF (yellow) OFF	No 318 MHz RF Received	<ul style="list-style-type: none"> • Battery in Remote • Program Remote • Antenna Receiver Connections • Antenna Receiver
Power (green) ON	AC or Solar Power Present	Normal Operation
Power (green) OFF	No AC or Solar Power	<p>Transformer:</p> <ul style="list-style-type: none"> • Breaker or GFI • Power at AC outlet. • Output of Transformer. • Voltage on wire at 18 VAC Input <p>Solar:</p> <ul style="list-style-type: none"> • Solar Panel Wires Reversed • Weather • Solar Panel Placement • Output of Solar Panel • Voltage on wire at Solar Input
Charge (red) ON	Fast Charging Mode	Battery Voltage should be increasing but must be less than 15 VDC when connected to the circuit board
Charge (red) Fast Blinking	Soak Charging Mode	Battery Voltage should be ~14.1 VDC when connected to the circuit board
Charge (red) Slow Blinking	Float Charge	Battery Voltage should be ~13.8 VDC when connected to the circuit board
Charge (red) OFF	Battery Not Being Charged	<ul style="list-style-type: none"> • AC power • Transformer • Solar Panel • Charging Circuit

Repair Service

If your Mighty Mule® Gate Opener is not operating properly, please follow the steps below:

1. First use the procedures found in the Maintenance & Troubleshooting Guide (see page 33).
2. For 24 hour 7 days a week trouble shooting and support online go to our TECH WIZARD site at... support.gtoinc.com/Support/TroubleShooter.aspx
3. If you are unable to solve the problem, call the **GTO Service Department** at (800) 543-1236, or (850) 575-4144. Refer to the serial number (located on the right hand side of the control box) and date of purchase when calling for assistance.
4. If repair or replacement of your gate opener is necessary, the Service Department will assign a **Return Goods Authorization (RGA) number** to you to track return of equipment.
5. Include a copy of your receipt and securely pack the component(s) authorized for return to the factory. Write the RGA number issued to you on the outside of the package in **LARGE BOLD PRINT**. Ship the package(s) freight prepaid to: **Gates That Open, LLC • 3121 Hartsfield Road • Tallahassee, Florida • USA 32303.**

NOTE: Products returned to GTO without a Return Goods Authorization (RGA) number in LARGE BOLD PRINT on the outside of the package WILL NOT be accepted. Items returned to GTO freight collect WILL NOT be accepted. Items returned without proof of purchase will not be repaired under warranty.



For 24 hour 7 days a week trouble shooting and support online go to our TECH WIZARD site at... support.gtoinc.com/Support/TroubleShooter.aspx

For out of warranty service and repair call the Mighty Mule National Repair Center at... 1-800-543-1236

The Gates That Open, LLC Technical Service Department is open
Monday – Friday 8:00 A.M. – 7:00 P.M. (Eastern Time)

Telephone (800) 543-1236
Telephone (850) 575-4144

Fax (850) 575-8950 • Web site: www.mightymule.com

Conversion Chart

Converting Metric Units to English Equivalents

When You Know	Multiply By	To Find	Symbol
centimeters	0.3937	inches	in. (or ")
meters	3.2808	feet	ft. (or')
kilograms	2.2046	pounds	lb. (or #)

Converting English Units to Metric Equivalents

When You Know	Multiply By	To Find	Symbol
inches	2.5400	centimeters	cm
feet	0.3048	meters	m
pounds	0.4535	kilograms	kg

Converting Temperature

deg. Celsius	$(^{\circ}\text{C} \times 1.8) + 32$	deg. Fahrenheit	$^{\circ}\text{F}$
deg. Fahrenheit	$(^{\circ}\text{F} - 32) \div 1.8$	deg. Celsius	$^{\circ}\text{C}$

For Your Records

Please record the product serial number (located on the right hand side of the control box), and the date and place of purchase in the spaces provided below. Refer to this information when calling GTO for service or assistance with your automatic gate opener.

Serial Number _____ **Date of Purchase** _____

Place of Purchase _____

Remember to keep all receipts for proof of purchase.



ACCESSORIES

Accessories are Available From Your Retail Store

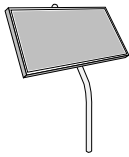

Solar Panel (FM121)

The **Solar Panel** is a 5 watt solar powered battery charger for use with the **Mighty Mule 600** gate operator systems. Particularly suited for remote installations, each **Solar Panel** comes with tubular steel support, mounting clips, wire connectors, and 8 ft. of low voltage wire (see Low Voltage Wire for additional wire). The **Mighty Mule®** control board has clearly labeled terminal connections for easy installation of the **Solar Panel**. Installation in some regions of the world will require multiple solar panels for adequate charging power. Dual gates require a minimum of 10 watts of solar charging power. (10 watt solar panels are available)



Push Button Control (FM132)

Unlit doorbell button for remote entry or exit control. Wires directly to the control board and uses 16 gauge multi-stranded, dual conductor low voltage wire (sold separately).

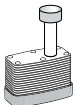

Pin Lock (FM133)

The **Pin Lock** substitutes for the clevis pin at the front end of the **Mighty Mule®** gate openers. Helps prevent theft of the operator from the gate, while allowing quick release of the operator.



Key Chain Two Button Transmitter (FM134)

The Key Chain Mini Transmitter is a miniature version of the **Mighty Mule®** entry transmitter and has the same adjustable code settings. (battery is included)



Single Button Transmitter (FM135)

The **Mighty Mule®** entry transmitter, with adjustable code settings, is standard equipment with all **Mighty Mule®** systems. (battery is included)



Digital Keypad (FM137)

The specially designed digital keypad can be easily installed as a wireless or wired keypad. It can be programmed to use up to 25 different personal identification number (PIN) codes. Each code is face programmable with additional security features built in. Wired installations require 16 gauge, low voltage, multi-stranded, dual conductor, direct burial wire (sold separately). Requires 3 AA batteries (not included).



Mounting Post (FM100) - In Ground

This black powder coated pedestal is designed to provide convenient access to your keypad, wireless intercom, or other access control device from your vehicle. With its break down design it is easy to install and works well in most standard applications. Surface Mount Flanges (F102) and Extensions (F103) for added height are available.

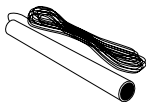

Mighty Mule® Vehicle Sensor (FM138)

The Gate Opening Sensor is designed for residential and agricultural applications and is compatible with most **Mighty Mule®** automatic gate opener models (see Sensor Box for model compatibility). The Sensor is an electromagnetic sensor, which offers 'hands free' operation of the **Mighty Mule®** Gate Operator with a 12 ft. radius of detection of vehicles in motion.



Automatic Gate Lock Pull-to-Open (FM143)

A MUST for added security. Solenoid driven, with a steel housing. Unlocks and locks automatically as gates open and close. Used with **Mighty Mule®** DC swing gate operating systems for maximum stability and security. Comes with a keyed manual release.

Accessories are Available From Your Retail Store (con't)



Wireless Entry Intercom / Keypad (FM136)

Allows owner to screen guest at the gate before allowing access to the property. Keypad also allows owner to give up to 25 programmable entry codes to family, friends or approved delivery personnel. Codes can be permanent or temporary. Up to 500 feet reception. Additional base stations available (F3101MBC).



Low Voltage Wire (RB509)

The 16 gauge, multi-stranded, dual conductor **Low Voltage Wire** is for connecting the AC powered transformer, or the **Solar Panel** to the control board. Also used for the connection of accessories, such as locks, keypads, push buttons and other wired control devices. This specially designed wire is UV treated, PVC coated and ready for direct burial. Available in 1000' rolls or special lengths.



Push to Open Bracket (FM148)

Required when **Mighty Mule 600** gate operator(s) must push the gate open, such as on a sloping driveway or where space prevents gate(s) from opening inward (pulled open).



Column Mount Lock Receiver (433IH)

For mounting the **Automatic Gate Lock** on brick columns, walls, or for other applications with limited space between gate and post.

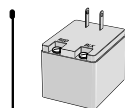

Replacement Transformer (RB570)

Standard 18 volt, 2200 mA, AC transformer for maintaining the battery included with the **Mighty Mule®** gate operator. This is the only transformer approved for use with **all UL325 Mighty Mule®** gate operator systems.



Garage Door Receiver (RB709U)

The Garage Door Receiver allows you to use the same **Mighty Mule®** entry transmitter to operate your gate operator and your garage door operator. Compatible with most garage door operators.

**If you have a question about any special order item,
just call 1-800-543-GATE!**

The contents of all material available on this installation manual are copyrighted by Gates That Open, LLC ("GTO"), unless otherwise indicated. All rights are reserved by GTO, and content may not be reproduced, downloaded, disseminated, published, or transferred in any form or by any means, except with the prior, written permission of GTO. Any reprinting of GTO publications is by permission only. Copyright infringement is a violation of federal law.

Mighty Mule®, E-Z Gate®, GTO®, are registered trademarks of Gates That Open, LLC. America's DIY Automatic Gate Openers is a trademark of Gates That Open, LLC and are the exclusive property of Gates That Open, LLC ("GTO").

All rights are reserved by GTO, and these marks may not be used, in any form without the prior, written permission of GTO.



3121 Hartsfield Road • Tallahassee, Florida, USA 32303
Telephone GTO Sales: 1-800-543-GATE (4283) or (850) 575-0176 • Fax (850) 575-8912
or GTO Technical Service: 1-800-543-1236 or (850) 575-4144 • Fax (850)575-8950
www.mightymule.com