

# MIGHTY MULE MM360

## Installation Manual

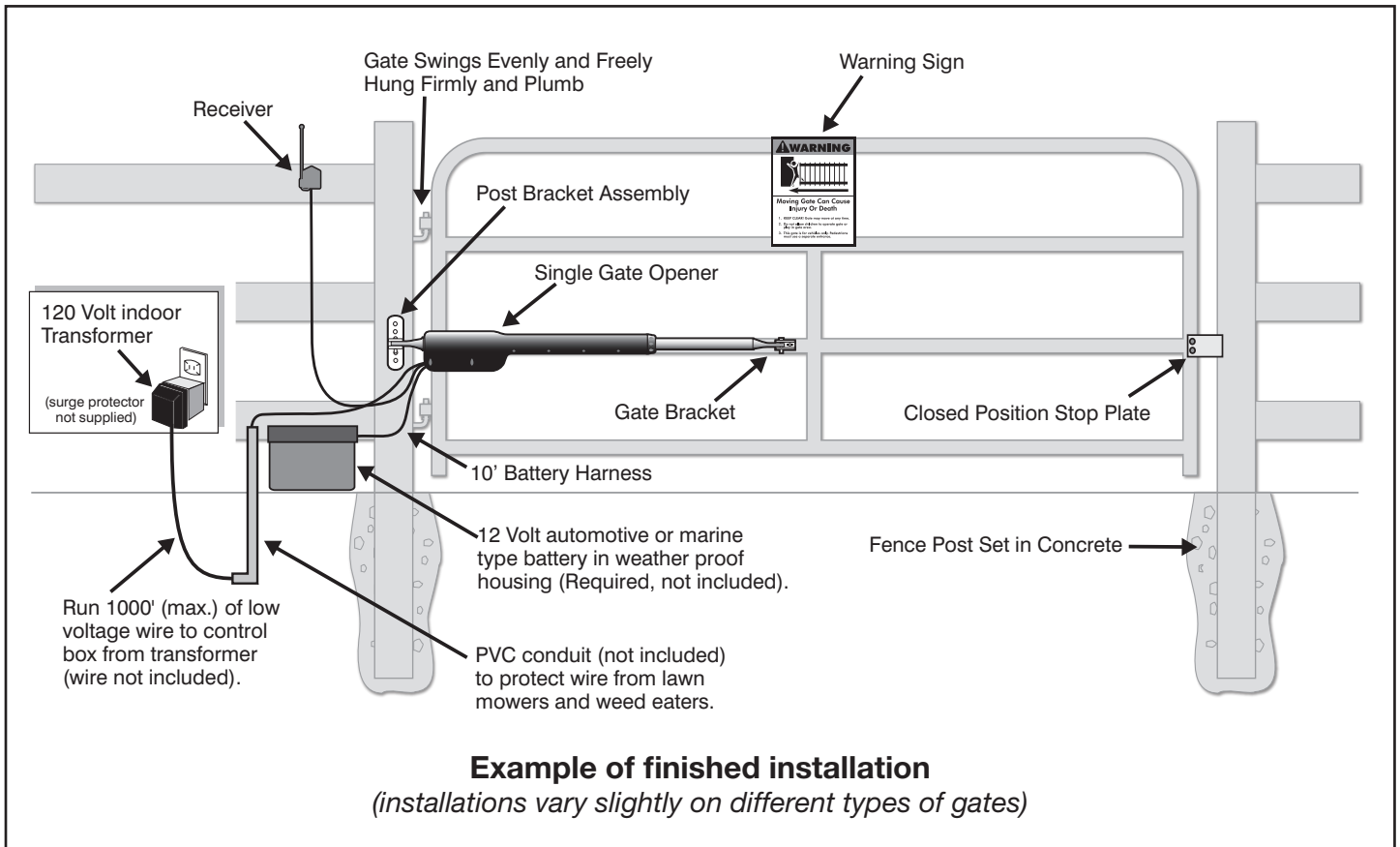

**Intertek**

This product meets the requirements of UL325 6th Edition, 2016, the standard for gate operator safety.

GTO Sales: 800-543-4283 • Fax 850-575-8912

GTO Technical Service 800-543-1236

For 24 hour/day, 7 day/week Technical Service visit <http://support.gtoinc.com>  
 For more information on Mighty Mule's full line of Automatic Gate Operators and Access Controls visit [www.mightymule.com](http://www.mightymule.com)

Mighty Mule® is the retail brand of GTO Access Systems, LLC  
 3121 Hartsfield Road • Tallahassee, FL 32303





# WARNING

This equipment meets Underwriters Laboratory Standard 325 (UL 325). However, gate equipment has hazards associated with its use and therefore by installing this product the installer and user accept full responsibility for following and noting the installation and safety instructions. Failure to follow installation and safety instructions can result in hazards developing due to improper assembly. You agree to properly install this product and that if you fail to do so GTO Access Systems, LLC, shall in no event be liable for direct, indirect, incidental, special or consequential damages or loss of profits whether based in contract tort or any other legal theory during the course of the warranty or at any time thereafter. The installer and/or user agree to assume responsibility for all liability and use of this product releasing GTO Access Systems, LLC, from any and all liability. If you are not in agreement with this disclaimer or do not feel capable of properly following all installation and safety instructions you may return this product for full replacement value.

**READ ALL INSTRUCTIONS CAREFULLY AND COMPLETELY** before attempting to install and use this automatic gate operator. This gate operator produces a high level of force. Stay clear of the unit while it is operating and exercise caution at all times.

**ALL AUTOMATIC GATE OPERATORS ARE INTENDED FOR USE ON VEHICULAR GATES ONLY.**

## Product Usage

The Mighty Mule Gate Operator meets all of the safety requirements of a **Class I** Residential Vehicular Gate Operator and is intended for use solely with vehicular swing gates in single-family residential applications that meet the Class I category listed in the table below.

### Vehicular Gate Operator Class Categories

**Residential Vehicular Gate Operator-Class I:**

A vehicular gate operator (or system) intended for use in garages or parking areas associated with a residence of one-to-four single families.

**Commercial/General Access Vehicular Gate**

**Operator-Class II:** A vehicular gate operator (or system) intended for use in a commercial location or building such as a multi-family housing unit (five or more single family units), hotel, garages, retail store, or other buildings accessible by or servicing the general public.

**Industrial/Limited Access Vehicular Gate**

**Operator-Class III:** A vehicular gate operator (or system) intended for use in an industrial location or building such as a factory or loading dock area or other locations not accessible by or intended to service the general public.

**Restricted Access Vehicular Gate Operator-**

**Class IV:** A vehicular gate operator (or system) intended for use in an industrial location or building such as a factory or loading dock area or other locations not accessible by or intended to service the general public.

# Table of Contents

Gate Opener Class Categories.....	inside cover
Units and Standards Conversion Chart.....	inside cover
<b>PLEASE READ THIS FIRST!</b> .....	page iv
<b>Important Safety Instructions</b> .....	<b>1</b>
Disconnecting the Opener.....	1
Important Safety Instructions for the Consumer .....	2
Safety Precautions for Gate Systems .....	5
Warning Signs and Labels.....	6
<b>Technical Specifications</b> .....	<b>8</b>
<b>Before You Begin</b> .....	<b>9</b>
Solar Chart .....	9
Check Direction of Gate Swing.....	10
Prepare the Gate.....	10
<b>Installation</b> .....	<b>11</b>
Parts List.....	11
Installation Overview .....	13
Installation of Mounting Hardware.....	14
Mounting the Opener.....	18
Installation of the Closed Position Stop.....	18
<b>Powering the System</b> .....	<b>20</b>
Connecting the Battery .....	20
Detailed Wire Routing Diagram .....	21
Connecting the Transformer .....	22
Connecting Solar Panel(s).....	23
<b>Control Board Settings</b> .....	<b>24</b>
DIP Switches .....	24
Mounting the Receiver .....	25
Setting the Closed Position Limit.....	26
Obstruction Sensitivity and Auto-Close.....	27
<b>Personalize Your Transmitter Setting</b> .....	<b>28</b>
<b>Connecting Accessories</b> .....	<b>29</b>
Wiring Accessories .....	30
<b>Push-to-Open Installation Instructions</b> .....	<b>32</b>
<b>Column Installation Information</b> .....	<b>35</b>
<b>Maintenance</b> .....	<b>35</b>
<b>Troubleshooting Guide</b> .....	<b>36</b>
<b>Warranty Repairs</b> .....	<b>38</b>
<b>Accessories</b> .....	<b>39</b>

**KEEP THESE INSTRUCTIONS FOR FUTURE REFERENCE**

# Please Read This First!

Thank you for purchasing a Mighty Mule Gate Operator—GTO's "do-it-yourself" automatic gate operator! When correctly installed and properly used, your Mighty Mule Gate Operator will give you many years of reliable service. Please read the following information and watch the enclosed video to ensure you have the correct system for your particular needs. Furthermore, this manual and the DVD will enable you to properly install your Mighty Mule Gate Operator.

The Mighty Mule Gate Operator is designed for installation on a pull-to-open single leaf gate (gates that open into the property). By purchasing an accessory bracket, the Mighty Mule Gate Operator can accommodate a push-to-open single leaf gate (gates that open out from the property). The gate must not exceed 16 feet in length or weigh more than 550 pounds (please see Technical Specifications on page 8). The Mighty Mule Gate Operator can be used on vinyl, aluminum, chain link, farm tube, and wrought iron gates. Use on solid surface gates is not recommended. Solid surface gates have a high resistance to the wind. If the wind is strong enough, the operator will obstruct and stop.

The Mighty Mule Gate Operator accommodates extra transmitters, digital keypads, solar panels, push buttons, automatic gate locks, and other access control products. These optional accessories (see the Mighty Mule Accessory Catalog) are available at most stores. Your store should be able to special order any accessory not in stock. If your store cannot special order accessories, please call the Mighty Mule Sales Department (800-543-GATE).

The Mighty Mule Gate Operator features Dual Sense Technology™. This feature makes the gate stop and reverse direction when it comes in contact with an obstruction. This is factory set to the most sensitive setting and must be adjusted during installation.

The Mighty Mule Gate Operator also has an adjustable auto-close feature. After the gate reaches the fully open position, it can be set to remain open up to 120 seconds before automatically closing. Pressing the transmitter button at any time after the gate opens fully will cause it to close immediately. OFF is the factory setting; meaning the gate will stay open until you press the transmitter (or keypad, etc.) again.

NOTE—If your application requires any of the following:

- Swing gates longer than 16 feet or weighing more than 550 pounds
- Slide gates
- Heavy duty or commercial uses
- Professional installation

Go to [www.gtoaccess.com](http://www.gtoaccess.com) for a dealer or retailer near you or call (800) 543-4283 for information about our Linear PRO Access professional line of gate operators and accessories. Our Sales Department will be glad to give you the name and phone number of a Linear PRO Access dealer near you.

**BEFORE YOU BEGIN TO INSTALL YOUR AUTOMATIC GATE OPERATOR:**  
watch the enclosed video and read these instructions carefully and completely to become familiar with all parts and installation steps. The video is only designed as an overview of the installation procedure. You must read the installation manual for detailed instructions on gate operator safety and proper use of the gate operator.



# Important Safety Information

Because automatic gate operators produce high levels of force, consumers need to know the potential hazards associated with improperly designed, installed, and maintained automated gate operator systems. **Keep in mind that the gate operator is just one component of the total gate operating system.** Each component must work in unison to provide the end user with convenience, security, and safety.

This manual contains various safety precautions and warnings for the installer end user. Because there are many possible applications of the gate operator, the safety precautions and warnings contained in

this manual cannot be completely exhaustive in nature. They do, however, provide an overview of the safe design, installation, and use of this product. **CAREFULLY READ AND FOLLOW ALL SAFETY PRECAUTIONS, WARNINGS, AND INSTALLATION INSTRUCTIONS TO ENSURE THE SAFE SYSTEM DESIGN, INSTALLATION, AND USE OF THIS PRODUCT.**

 Warnings in this manual are identified with this warning symbol. The symbol identifies conditions that can result in damage to the operator or its components, serious injury, or death.

**Because Mighty Mule automatic gate operators are only part of the total gate operating system, it is the responsibility of the installer and end user to ensure that the total system is safe for its intended use.**

## Manually Opening and Closing Gate

### CAUTION

The gate will move freely and uncontrolled when the gate operator is removed from the gate. **ONLY** disconnect the operator when the control box power switch is **OFF** and the gate is **NOT** moving.

#### Disconnecting the Operator

1. Turn control box power switch OFF.
2. Remove hairpin clip, clevis pin, and bushing from either the front or rear mounting point.
3. Remove the operator from the mount.

The gate can be opened and closed manually when the operator is disconnected.

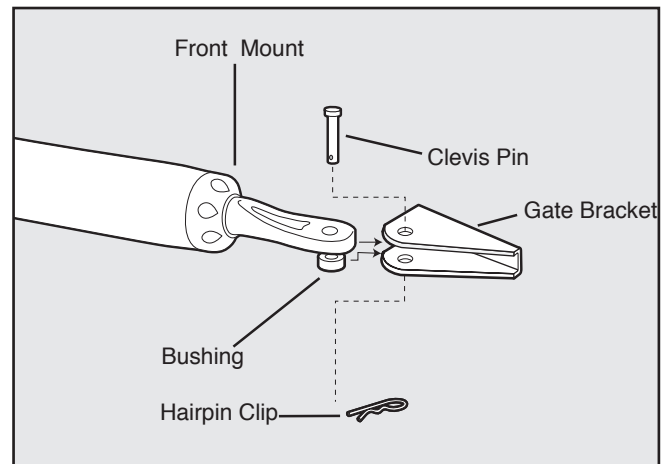

**NOTE:** Substitute a **Pin Lock** for the clevis pin on the front mount of the gate operator to prevent unauthorized theft of the operator from the gate (see accessory pages in back of this book).

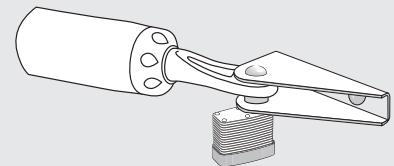

# Important Safety Information

## For the Installer and End User

### **WARNING**

#### To reduce the risk of injury or death:

1. **READ AND FOLLOW ALL INSTRUCTIONS.**
2. Never let children operate or play with gate controls. Keep the remote control away from children.
3. Always keep people and objects away from the gate. **NO ONE SHOULD CROSS THE PATH OF THE MOVING GATE.**
4. Test the gate operator monthly. The gate **MUST** reverse on contact with a rigid object or stop when an object activates the non-contact sensors. After adjusting the force or the limit of travel, retest the gate operator. Failure to adjust and retest the gate operator properly can increase the risk of injury or death.
5. Use the manual/emergency release only when the gate is not moving.
6. **KEEP GATES PROPERLY MAINTAINED.** Read the user's manual. Have a qualified service person make repairs to gate hardware.
7. The entrance is for vehicles only. Pedestrians must use separate entrance.
8. The gate must be installed in a location that provides adequate clearance between it and adjacent structures when opening and closing to reduce the risk of entrapment. Swinging gates must not open into public access areas.
9. **SAVE THESE INSTRUCTIONS.**

#### I. Before Installation

1. Verify this operator is proper for the type and size of gate, frequency of use and class of the gate system.
2. Make sure the gate has been properly installed and swings freely in both directions. Repair or replace all worn or damaged gate hardware prior to installation. A freely moving gate will require less force to operate and will enhance the performance of the entrapment protection devices used with the system (see page 10).
3. Review the operation of the system to become familiar with its safety features. Understand how to disconnect the operator for manual gate operation (see page 1).
4. The gate and operator installation must comply with any applicable local codes.
5. This gate operator is intended for vehicular gates only. A separate entrance or gate must be installed for pedestrian use (see page 6).
6. Always keep people and objects away from the gate and its area of travel. No one should cross the path of a moving gate.
7. Identify all of the entrapment zones for the type of installation. An entrapment zone is an area around the automatic gate system where a person or object could be caught that increase the risk of injury. Entrapment zones must be eliminated, guarded or protected.
8. When designing a system that will be entered from a highway or main thoroughfare, make sure the gate system is placed far enough from the road to prevent traffic congestion.

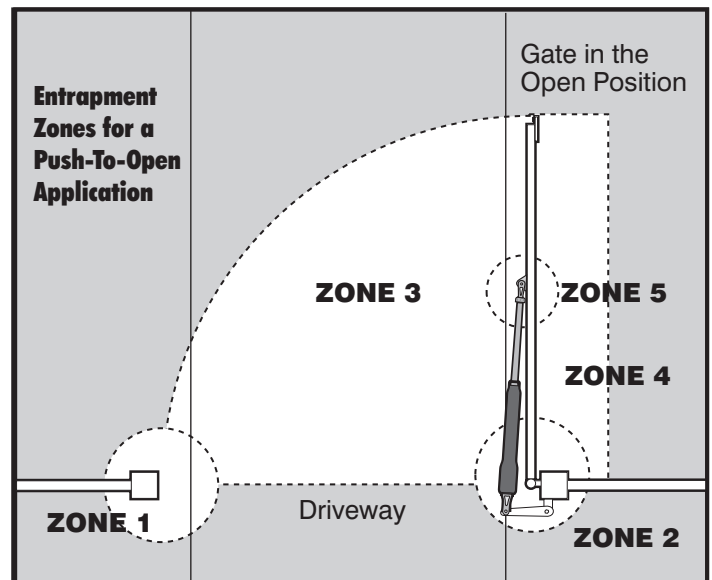
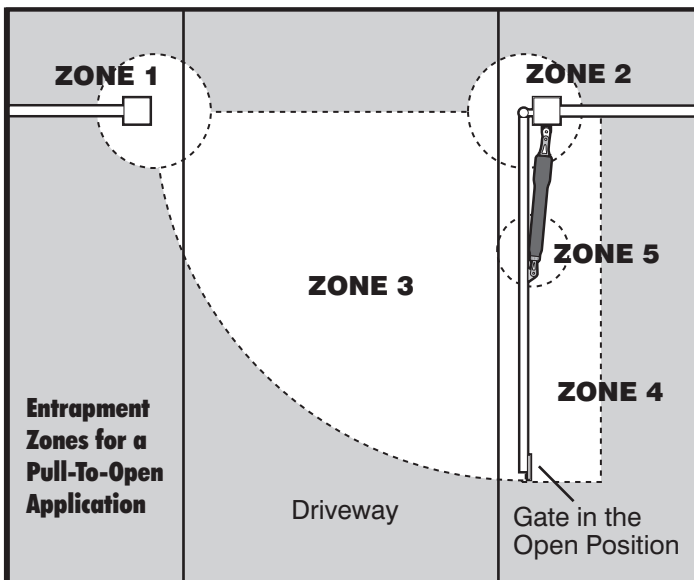

# Important Safety Information

## For the Installer and End User

Typical Entrapment Zones are shown in the diagrams on page 2:

Zone 1 – leading edge of the gate and the fence post.

Zone 2 – between the gate and the gate post.

Zone 3 – the path of the gate.

Zone 4 – the space between the gate in the open position and any object such as a wall, fence, tree, etc.

Zone 5 – pinch points between the operator and gate.

## II. During Installation

1. Install the gate operator on the inside of the property and fence line. **DO NOT** install an operator on the outside of the gate where the public has access to it.
2. Be careful with moving parts and avoid close proximity to areas where fingers or hands could be pinched.
3. Devices such as contact sensors (sensing edges) and non contact sensors (photo beams) provide additional protection against vehicular damage.
4. If push buttons or key switches are installed, they should be within sight of the gate, located at least 10 feet from any moving part of the gate (see diagram below). **Never install any control device where a user will be tempted to reach through the gate to activate the gate operator.**
5. Do not activate your gate operator unless you can see it and can determine that its area of travel is clear of people, pets, or other obstructions. Watch the gate through its entire movement.
6. Secure outdoor or easily accessed gate operator controls in order to prohibit unauthorized use of the gate.

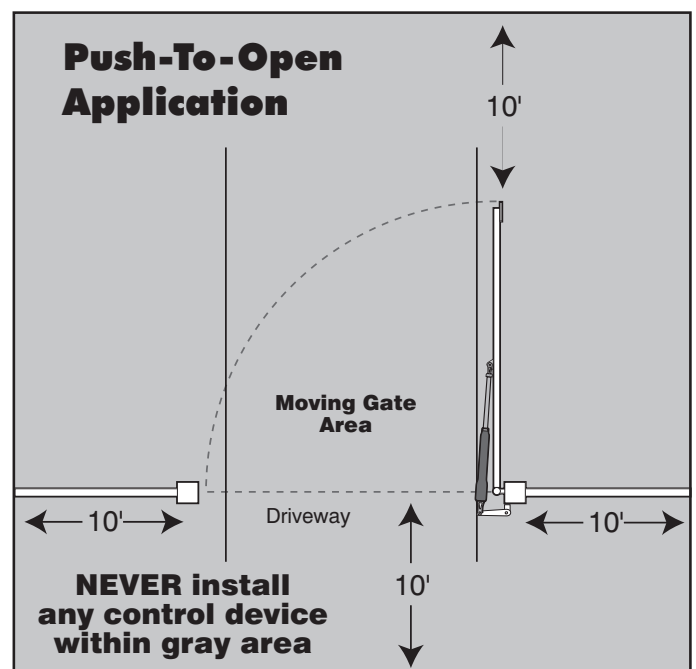
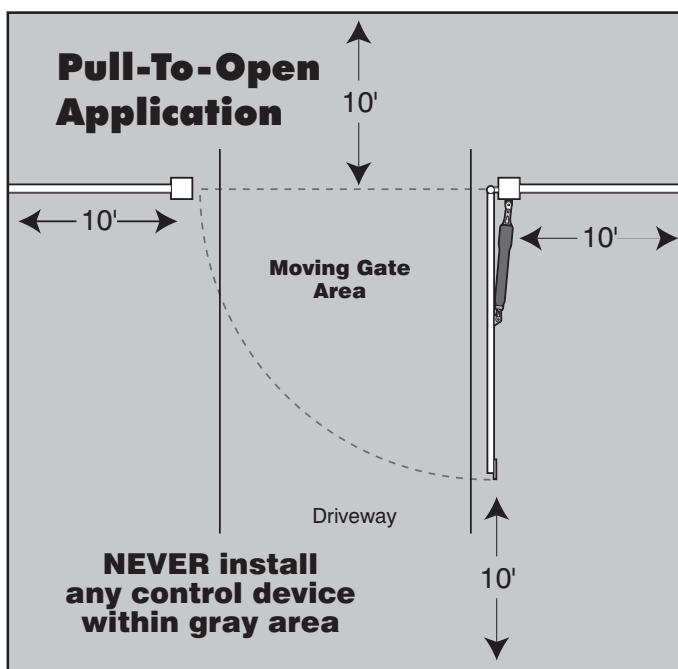



# Important Safety Information

## For the Installer and End User

### III. After Installation

1. Attach the **warning signs** (included) to each side of the gate to alert the public of automatic gate operation. It is your responsibility to post warning signs on both sides of your gate. If any of these signs or warning decals becomes damaged, illegible, or missing, replace them immediately. Contact GTO for free replacements.
2. The gate is automatic and could move at any time, posing serious risk of entrapment. No one should be in contact with the gate when it is moving or stationary.
3. Do not attempt to drive into the gate area while the gate is moving; wait until the gate comes to a complete stop.
4. Do not attempt to “beat the gate” while the gate is closing. This is extremely dangerous.
5. Do not allow children or pets near your gate. **Never let children operate or play with gate controls.** Keep the remote control away from children and unauthorized users; store controls where children and unauthorized users do not have access to them.
6. **KEEP GATE SYSTEMS MAINTAINED.** Always turn power to operator OFF before performing any maintenance. See page 35 for maintenance procedures.
7. To operate this equipment safely, YOU must know how to disconnect the operator for manual gate operation (see page 1). If you have read the instructions and still do not understand how to disconnect the operator, contact the Mighty Mule Service Department.
8. Disconnect the operator **ONLY** when the power is **TURNED OFF** and the gate is **NOT** moving.
9. Make arrangements with local fire and law enforcement for emergency access.
10. Distribute and discuss copies of the **IMPORTANT SAFETY INFORMATION** section of this manual with all persons authorized to use your gate.
11. **IMPORTANT: Save these safety instructions. Make sure everyone who is using or will be around the gate and gate operator are aware of the dangers associated with automated gate systems. In the event you sell the property with the gate operator or sell the gate operator, provide a copy of these safety instructions to the new owner.**

**Should you need a replacement manual, a copy can be obtained by downloading one from the Mighty Mule web site ([www.mightymule.com](http://www.mightymule.com)), by contacting GTO, at 3121 Hartsfield Road, Tallahassee, Florida 32303 or by calling 1-800-543-4283 and requesting a duplicate copy.**



# Important Safety Information

## For the Installer and End User

Mighty Mule gate operators utilize Dual Sense Technology™ entrapment protection. Dual Sense Technology™ is built into every Mighty Mule and provides redundant methods of entrapment protection for open and close gate directions.

In addition to Dual Sense Technology, every Mighty Mule gate controller has provisions for the connection of additional obstruction detection devices such as sensing edges and photo beams.

These devices may be located where there is an increased risk of obstruction. Refer to the diagram below.

One or more edge sensors may be located at the leading edge, bottom edge, and post edge, both inside and outside of a vehicular swing gate system.

Wiring to sensors must be located and arranged so the wiring between the sensor and the gate operator is not subjected to mechanical damage.

A wireless sensor such as one that transmits radio frequency (RF) signals to the gate operator for obstruction protection functions shall be located where the transmission of the signals is not blocked or impeded by building structures, natural landscaping or similar objects.

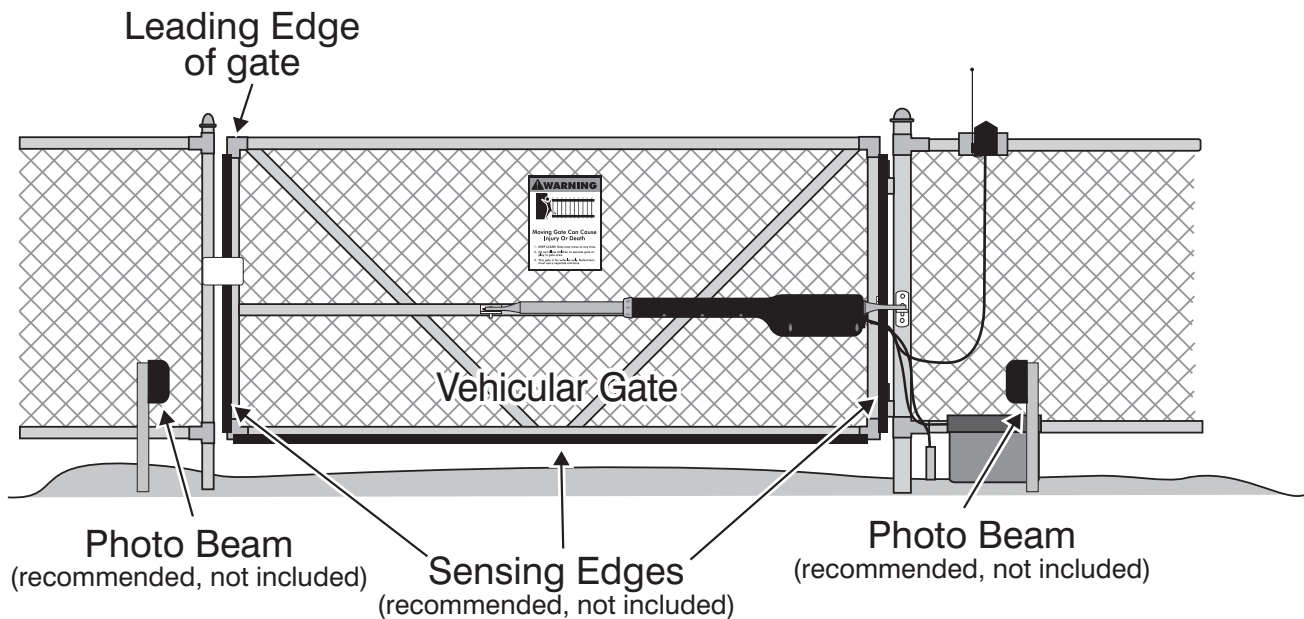

## Entrapment and Obstruction Protection

Mighty Mules' Dual Sense Technology™ provides entrapment protection when properly adjusted. Since all installations are different, you may need to add photo beams or sensing edges to help prevent damage to vehicle or other items that could be hit by a moving gate.

## Entrapment Alarm

The Mighty Mule Automatic Gate Operator is designed to stop and reverse the gate when the gate comes in contact with an obstruction. Additionally, these operators are equipped with an audio entrapment alarm which will activate if the unit obstructs twice while opening or closing. This alarm will sound for a period of 5 minutes, or until the operator receives an intended signal from a hard wired entry/exit source (e.g. push button control or keypad) and the gate returns to a fully open or fully closed position. Turning the power switch on the control box OFF and back ON will also deactivate the alarm. Wireless controls such as transmitters and wireless keypads will not deactivate the alarm.

# Important Safety Information

## Installing Warning Signs and Pedestrian Gates

Warning signs alert people of automatic gate operation and are required when installing Mighty Mule Automatic Gate Operators. A minimum of two WARNING SIGNS must be installed in the area of the gate. Each sign is to be visible by persons located on the side of the gate on which the placard is installed.

The operator is intended for installation only on gates used for vehicles. Pedestrians must be supplied with a separate access. The pedestrian access shall be designed to promote pedestrian usage. Locate the gate such that persons will not come in contact with the vehicular gate during the entire path of travel of the vehicular gate.

We recommend using the GTO Bulldog Pedestrian Gate Lock (Call the GTO Sales Department at 800-543-4283) for controlled access.

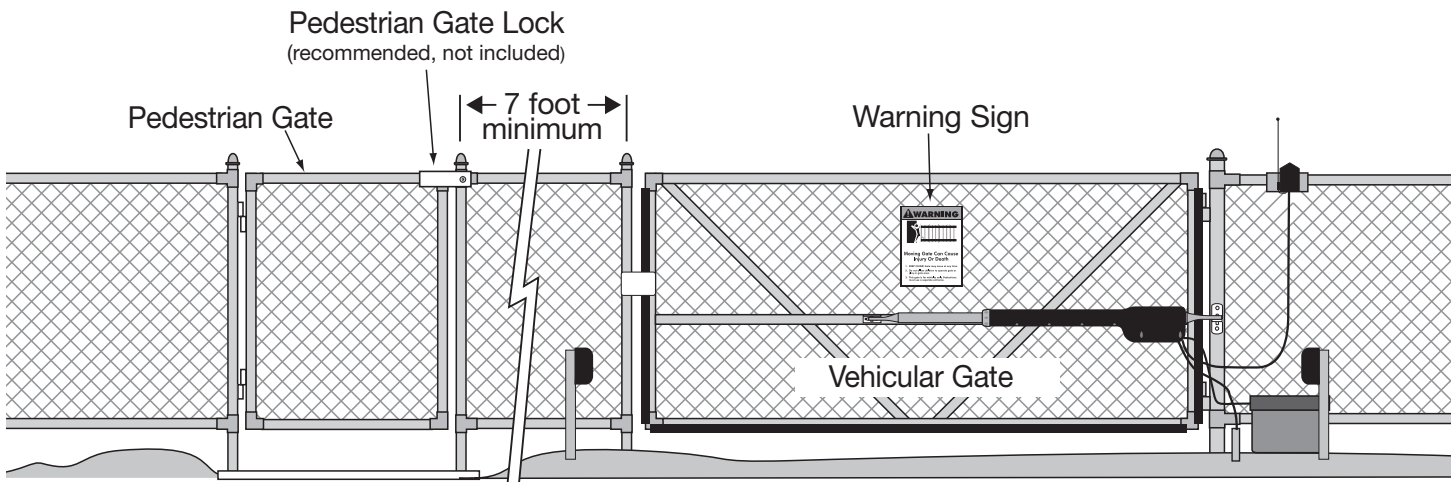

### Warning Signs

The gate operator is provided with 2 safety warning signs. The signs **MUST** be installed on the front and back of the gate where they will be visible in the area of the gate.

Permanently secure each warning sign to the gate.

Immediately replace a damaged or missing warning sign.



# Important Safety Information

## Required Safety Precautions for Gates

These warning labels should be found at the locations specified below. If any of them are missing, immediately contact GTO for replacements.



*Logo and warning labels (2) installed on each side of operator housing*

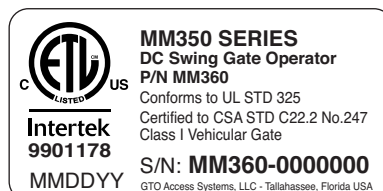

*Product identification label (1)  
installed under rear mount on arm.*

# Technical Specifications

## MIGHTY MULE 360 GATE OPENER

### DRIVE

- Low friction screw drive (linear actuator) rated for -5 °F to +160 °F (-20 °C to +71 °C).
- Powered by a 12 V motor with integral case hardened steel gear reducer. Motor speed reduced to 260 rpm.
- Maximum opening arc of 110°. Approximate opening time (90°): 18 seconds, depending on weight of gate.

### POWER

- The system is powered by a 12 Vdc automotive or marine battery.
- Battery charge is maintained by a 120 Vac, 18 Vac output transformer (40 VA) through the GTO control board or by optional GTO Solar Panels; the panel should generate minimum of 5 Watts at 300 mA. **IMPORTANT: Never use both transformer and solar panel— this will damage the battery and control board.**
- One (1) blade-style fuse is rated for 15 A.

**NOTE: The transformer should not be directly connected to any battery. Do not replace fuses with higher ampere rated fuses; doing so will void your warranty and may damage your control board.**

### CONTROL

- GTO DIP switches are set for single leaf, pull-to-open gate installations. DIP switches can be adjusted to accommodate push-to-open gates.
- A circuit on the control board regulates charging. "Sleep draw" is 25 mA; "active draw" is 2 to 5 A.
- Auto-memorization of digital transmitter code.
- GTO RF Receiver tuned to 318 MHz.
- Opener length with push-pull tube fully retracted is 37 1/4", mounting point to mounting point. Maximum stroke is 19".
- Adjustable auto-close timer (OFF to 3–120 seconds), and Dual Sense Technology stall force.
- Power terminal block accommodates a transformer or solar panels.
- Accessory terminal block fully compatible with all Mighty Mule access controls.
- Control board allows connection of edge sensors and photoelectric sensors.
- Audio entrapment alarm sounds if unit encounters an obstruction twice while opening or closing.

### OPERATIONAL CAPACITY

- The Gate Capacity Chart shows approximate cycles, per day, you could achieve prior to the 12 Volt battery depleting to a state where the unit will not function. This chart reflects a Mighty Mule Automatic Gate Opener when charging with a transformer and 12 Volt battery. Actual cycles may vary slightly depending upon the type and condition of gate and installation.

#### Mighty Mule 360 Gate Capacity /Cycle Chart

*Estimated number of daily cycles, based on use with a transformer and one(1) 12 Volt battery.*

		Number of Cycles Per Day						
Gate Weight	550 lbs.	125	115	NR	NR	NR	NR	
	450 lbs.	135	125	115	NR	NR	NR	
	350 lbs.	145	135	125	115	NR	NR	
	250 lbs.	155	145	135	125	115	NR	
	150 lbs.	165	155	145	135	125	115	
	100 lbs.	175	165	155	145	135	125	
	50 lbs.	185	175	165	155	145	135	
		5' - 6'	8'	10'	12'	14'	16'	
		Gate Length			NR=not recommended			

*An operation cycle is one full opening and closing of the gate.*

\* These specifications are subject to change without notice.

**NOTE: BALL BEARING HINGES SHOULD BE USED ON ALL GATES WEIGHING OVER 250 LBS.**

To determine the number of cycles the gate opener will perform using solar panels (see page 9)

# Before You Begin

## 1. Determine Charging Options for Battery: Transformer OR Solar

**NEVER USE TRANSFORMER AND SOLAR PANEL(S) AT THE SAME TIME!**  
**It will damage the control board!**

### IMPORTANT:

- The 12 volt automotive/marine battery must be charged by either connecting the transformer (included) or solar panel kit to the control board.
- The transformer is designed for indoor use. If the transformer can be plugged only into an outside electrical outlet, a weatherproof cover/housing (available at local electrical supply stores) must be used.
- If your gate is more than 1000 ft. from an AC power source, you will need to use at least 5 watts solar charging power to charge the battery. Refer to the Solar Panel and Gate Activity chart below.
- All low voltage wire used with the Mighty Mule Gate Opener must be 16 gauge, dual conductor, stranded, direct burial wire. Do not run more than 1000 ft. of wire.

## Solar Panel and Gate Activity Chart

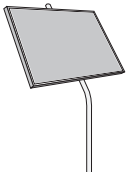

The table and map illustrate the maximum number of gate cycles to expect per day in a particular area when using from 5 to 30 watts of solar charging power prior to the battery depleting to a state where the unit will not function. The figures shown are for winter (minimum sunlight) and do not account for the use of any accessory items.

**Accessories connected to your system will draw additional power from the battery and will require additional solar panels. A deep cycle marine battery is recommended for solar and/or high traffic applications.**

NOTE: UP to 250 ft. of 16 gauge dual conductor, stranded, direct burial wire may be used to allow installation of solar panels in direct sunlight.

### Solar Charging Options

- 10 Watt Mighty Mule Solar Panel [FM123]
- 5 Watt Mighty Mule Solar Panel [FM121]

(See accessories on pg. 39)

Single Gate Winter Ratings	Zone 1	Zone 2	Zone 3
12 v single gate (5 watts) solar charger	4	8	13
12 v single gate (10 watts) solar charger	8	16	26
12 v single gate (15 watts) solar charger	11	20	30
12 v single gate (20 watts) solar charger	14	28	38
12 v single gate (25 watts) solar charger	17	36	46
12 v single gate (30 watts) solar charger	20	44	54

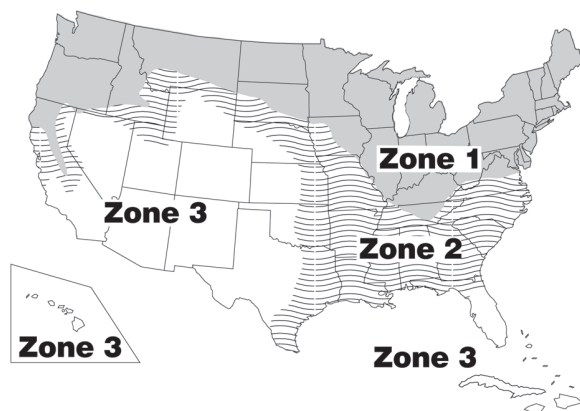

## 2. Check Direction of Gate Swing

The Mighty Mule Gate Opener is designed for **PULL-TO-OPEN** installations. **PUSH-TO-OPEN** installations require a Push-To-Open bracket [FM148, not included]. Push-to-Open Installation Instructions begin on page 32.

## 3. Prepare the Gate

- The gate must be plumb, level, and swing freely on its hinges.
- Wheels must **NOT** be attached to the gate.
- The gate must move throughout its arcs **without binding or dragging on the ground**.
- Note that a gate **over 250 lbs. should have ball bearing hinges** with grease fittings.
- The gate post should be secured in the ground with concrete so it will minimize twist or flex when the opener is activated.
- Make sure there is a stable area for mounting the gate bracket (this may require the addition of a horizontal or vertical cross member).

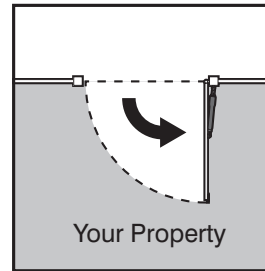

**Pull-To-Open**  
(arm retracts to open)

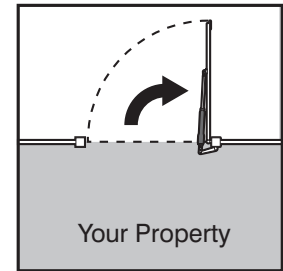

**Push-To-Open**  
(arm extends to open)

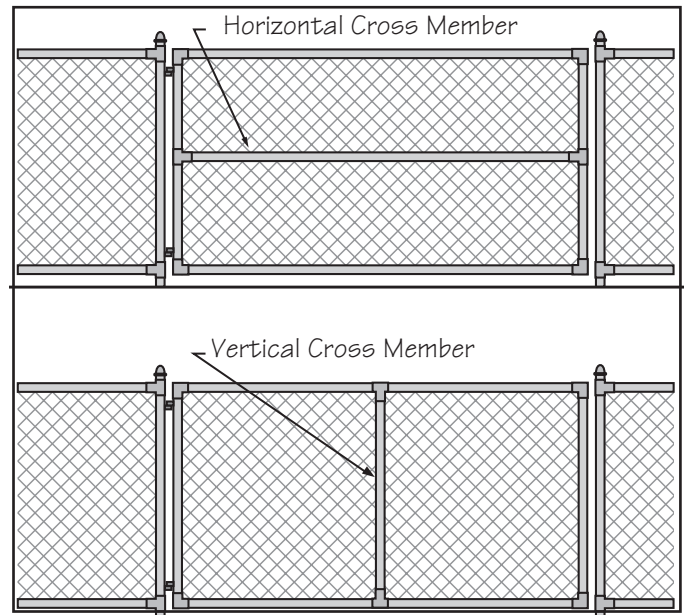
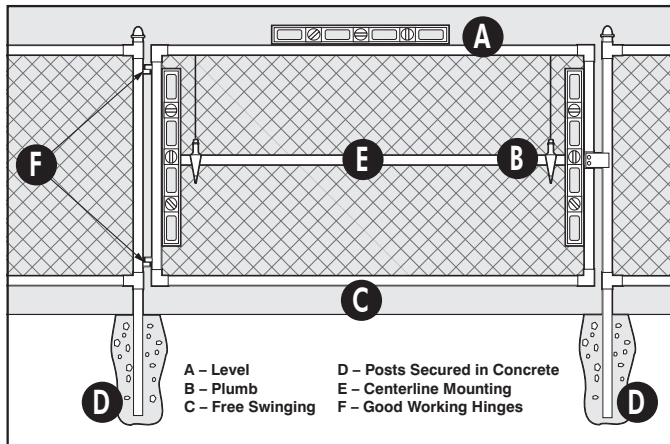

## Gate Grounding (recommended)

- Shorter wire (6 AWG) is better, 1 to 2 feet recommended.
- Bolt ring terminal at end of cable 4 - 6 inches above ground level.

R4196 Kit Includes:

- Ground Rod Clamp
- 6 AWG Wire (3 feet)

NOTE: No grounding system absolutely protects against lightning strikes. If installed correctly, a grounding system will help minimize damage to your gate opener.

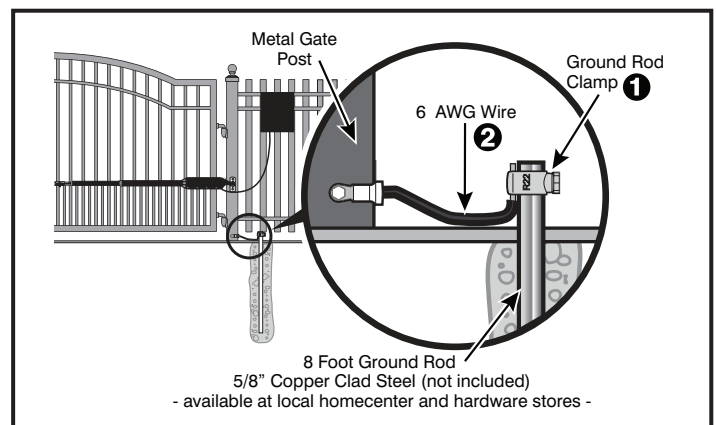



# Parts List – Opener and Mounting Hardware

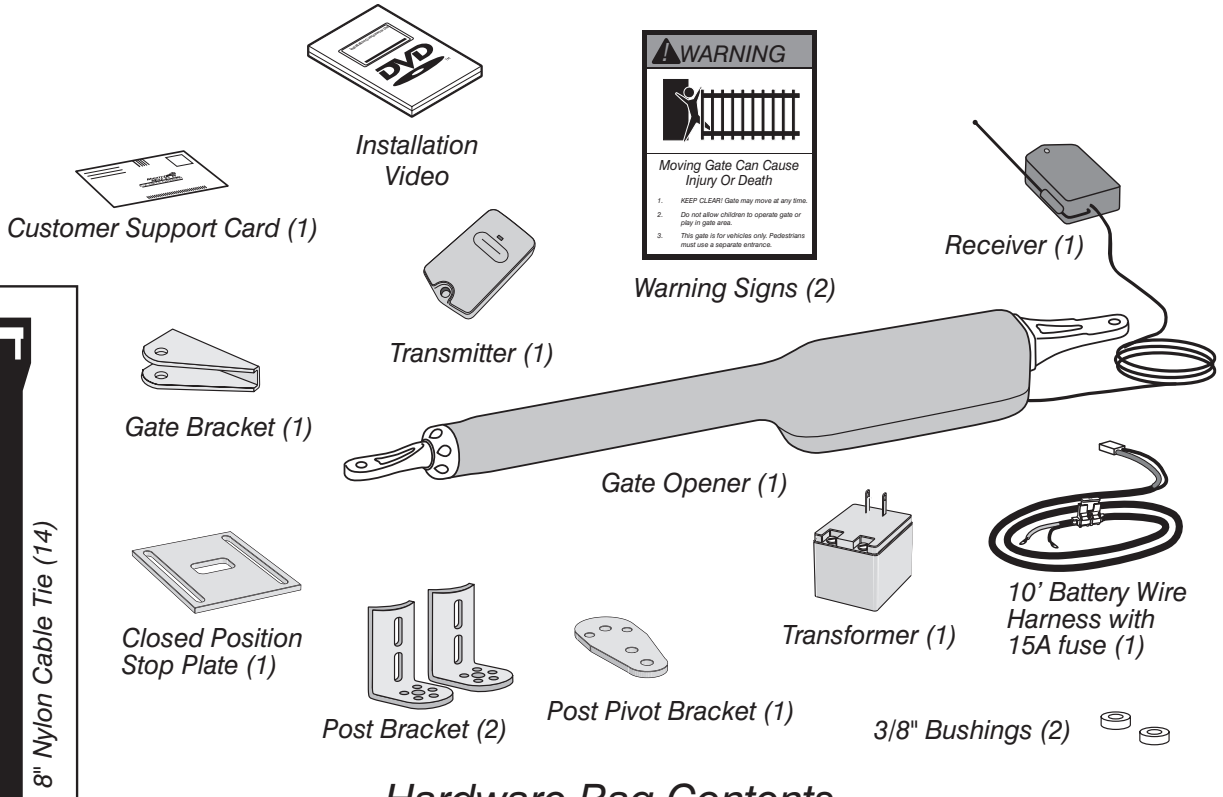

## Hardware Bag Contents

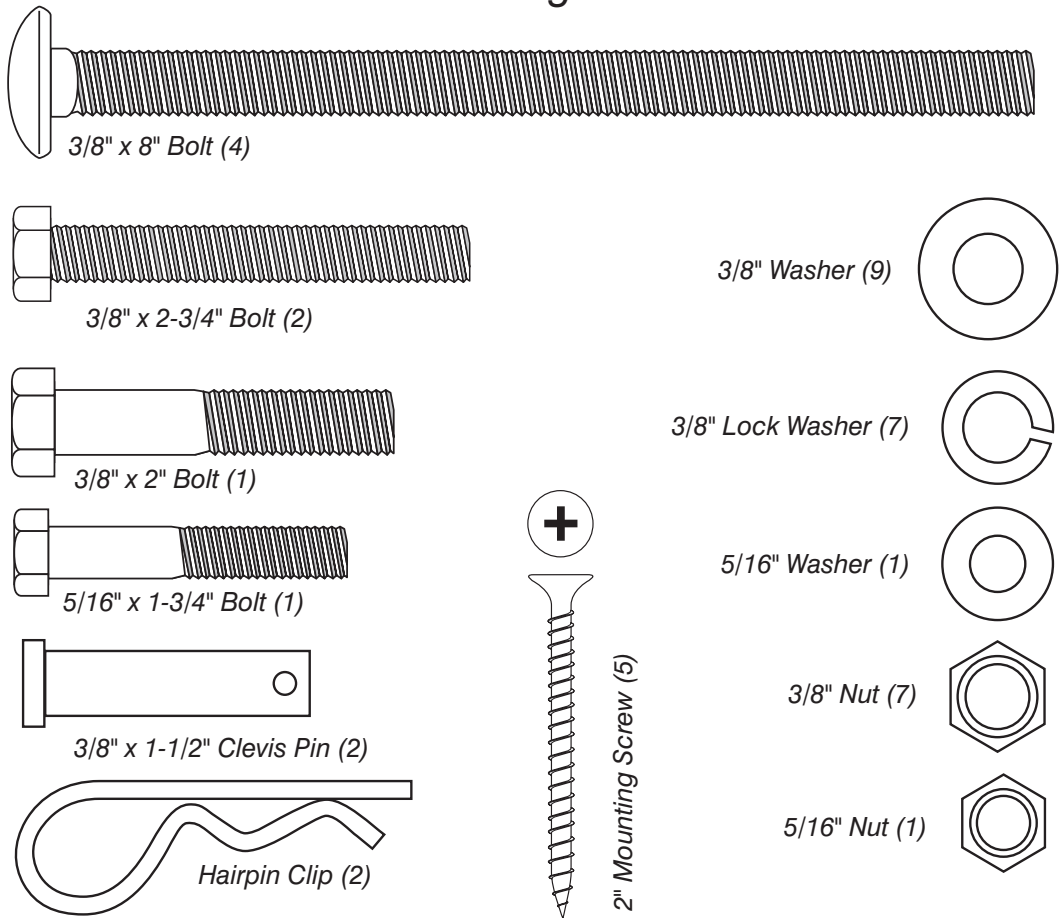



# Tools and Materials

## Tools Needed:

- Power Drill
- Open End Wrenches — 1/2" and 9/16"
- Adjustable Wrench
- 3/8" Drill Bit
- Hacksaw or Heavy Duty Bolt Cutters
- Small Flat Bladed Screwdriver
- Large Phillips Screwdriver
- Tape Measure
- Level
- Wire Strippers
- C-Clamps — small, medium, and large
- Center Punch
- Hammer (for center punch)
- Extra person will be helpful

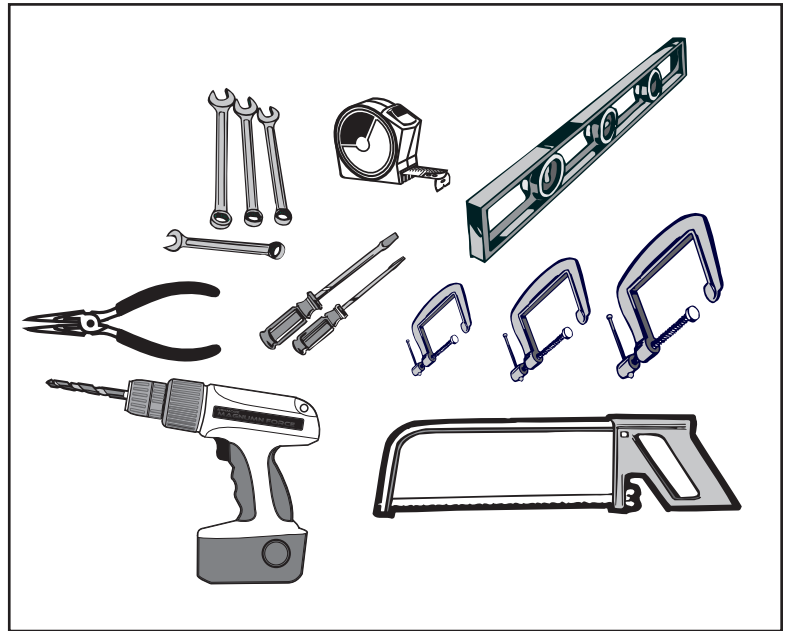

Note: Not all tools shown.

---

## Materials You May Need for the Installation:

These items are **NOT included** with the gate opener kit. Some of these items can be purchased separately.

- Low voltage wire [RB509] will be needed to run from the transformer to the opener control board; length depends upon the distance between the transformer power supply and the control arm.
- If your gate is more than 1000' away from an AC power source you will need to use at least one 5 Watt solar panel [FM121] to charge the 12 Volt battery.
- PVC conduit for protecting wiring.
- Push-To-Open Bracket [FM148] is required if gate opens out from property.
- Materials to reinforce thin walled tube or panel gates (see page 14).
- Depending on the type of gate, a horizontal cross member or mounting plate may be needed to mount the front of the opener and gate bracket to the gate.
- Some installations may require muffler clamps for the gate bracket (see page 14).
- Surge protection for transformer.
- Weather proof outlet and cover is required if transformer is plugged into outside outlet.
- Some types of installations require U-Bolts for closed position stop plate.

# Installation Overview for Pull-To-Open Gates

**PUSH-TO-OPEN** installation instructions begin on page 32.

The diagram shown below is an example of a pull-to-open installation on a chain link fence and single gate. Mounting the opener on a masonry column may require special procedures. Furthermore, if you have a push-to-open gate, you will need to purchase a **push-to-open bracket [FM148]** to properly configure your system. See **Push to Open Installation** on page 32 before proceeding.

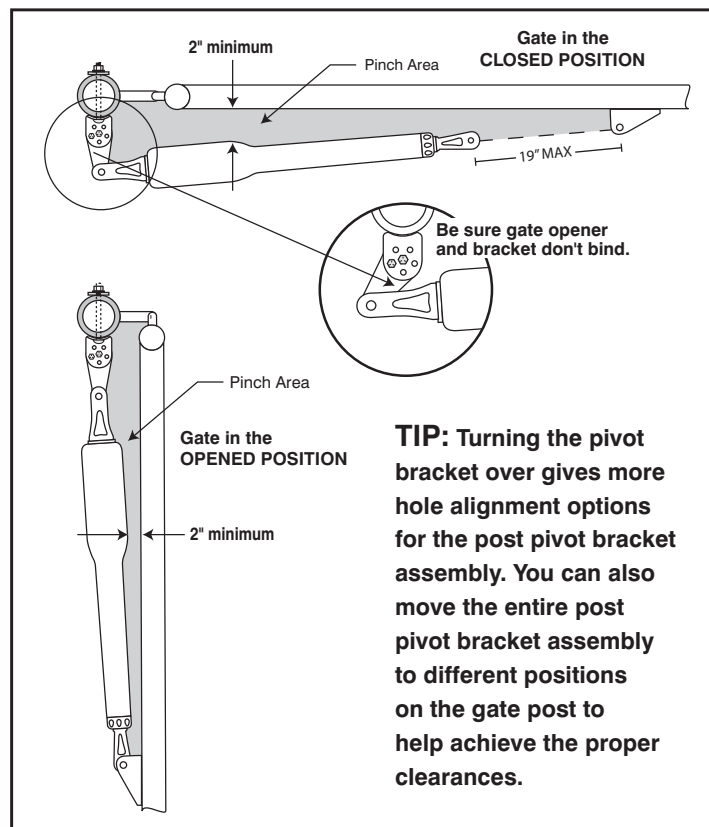
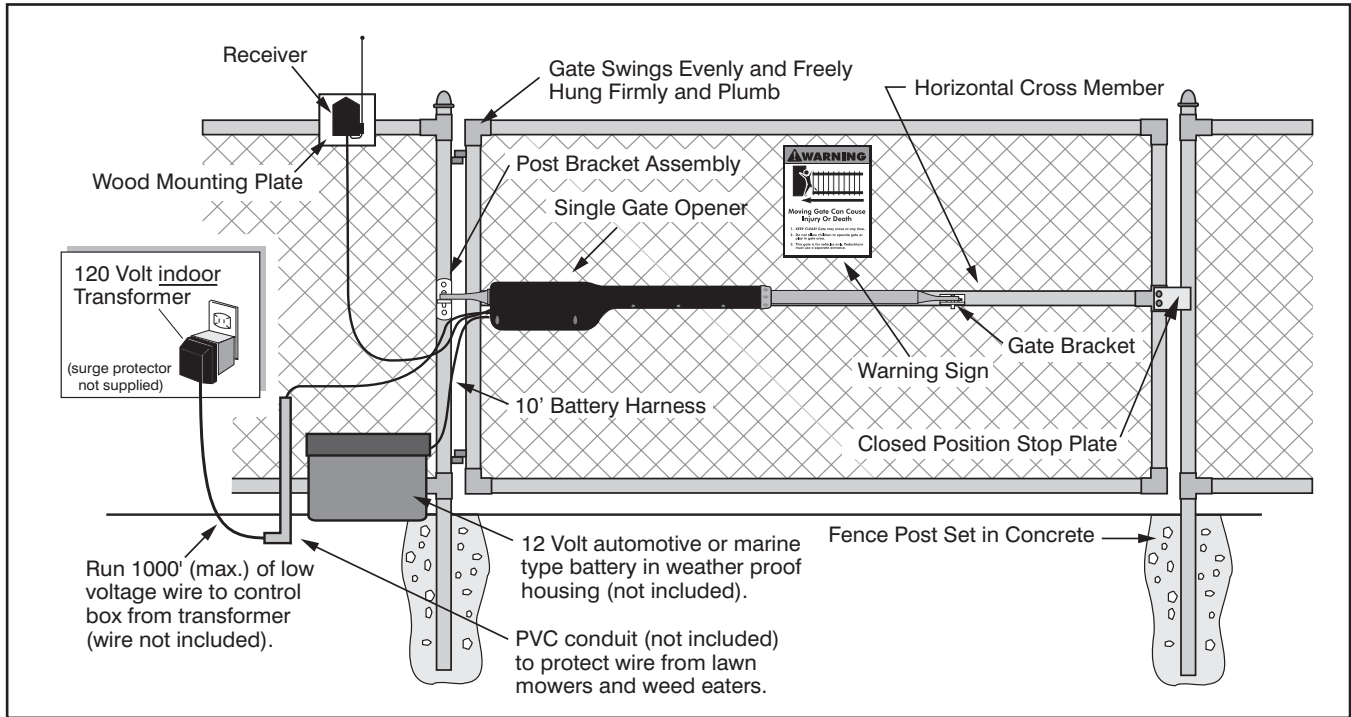

# INSTALLATION OF MOUNTING HARDWARE

We recommend you position the opener near the **centerline** of the gate to keep the gate from twisting and flexing and to avoid back splash from rain water.

## The Post Bracket Assembly

The position of the post bracket assembly determines the leverage and efficiency of the opener. The post bracket assembly position also sets the clearance between the opener and the gate in the open and closed positions.

The post bracket works well for installations on round and square fence posts. Because the post bracket carries the entire thrust of the active opener, **bolts must completely penetrate the post.**

On wood posts, place a metal plate or washer (not supplied) between the nuts and the post to prevent the thrust of the opener from pulling the bolts and washers out of the wood.

The post pivot bracket may not be necessary on posts larger than 6" in diameter. Fence posts smaller than 6" in diameter or 6" square should be made of metal instead of wood to remain stable while the opener is moving the gate.

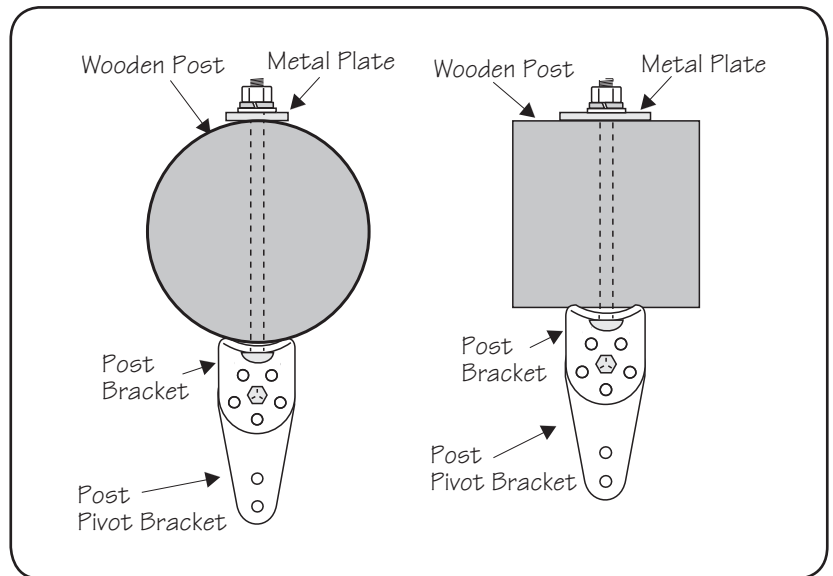

## Reinforcing Gates for the Gate Brackets

We **recommend** using a muffler clamp, wood, or metal, to reinforce thin-walled tube gates, or wood to reinforce panel gates as shown. These reinforcement methods will prevent damage to the opener and gate. Additional hardware may be needed depending on the installation.

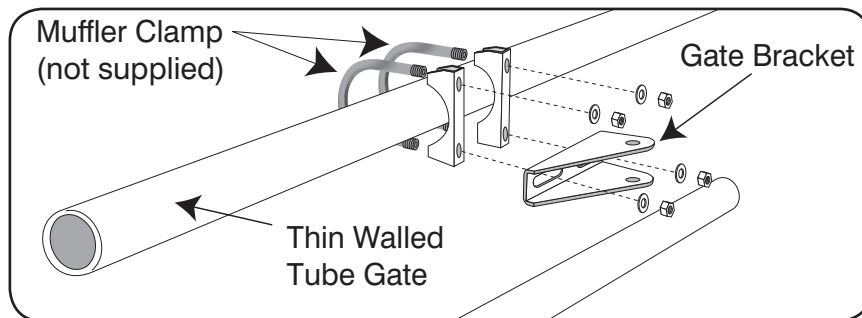

Muffler Clamp for Gate Bracket (does not require drilling and is adjustable)

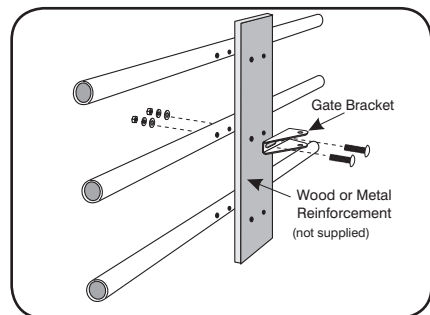

Wood or Metal Reinforcement

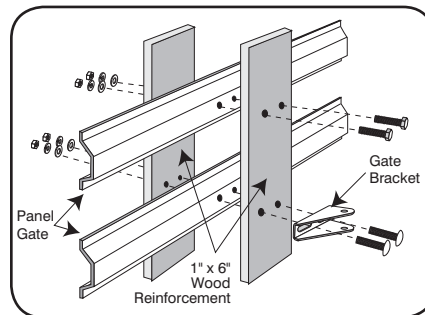

1" x 6" Wood Reinforcement

# Install Post Bracket Assembly and Gate Bracket

## Step 1

Insert the 3/8" x 2" bolt through the center hole of the post brackets and post pivot bracket as shown. Fasten a 3/8" washer, 3/8" lock washer and 3/8" nut on the end of the bolt. **DO NOT overtighten** the nut because the post pivot bracket will have to be adjusted later.

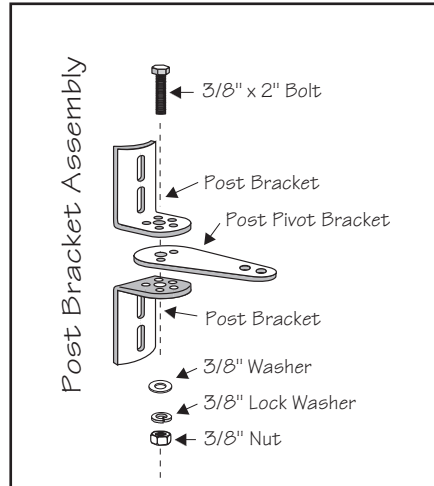

**NOTE:** The following steps are intended for **pull-to-open** gate installations. If you are mounting your opener on a push-to-open gate (e.g., a gate on a sloped driveway) you will need to purchase a **FM148**. Also, see **Push-to-Open Installation** beginning on page 32.

## Step 2

Attach post bracket assembly and gate bracket to the opener with the clevis pins and bushings. Secure the clevis pins with hairpin clips.

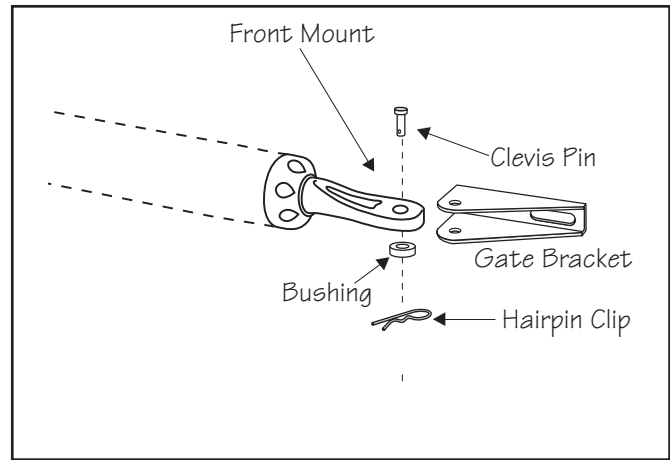
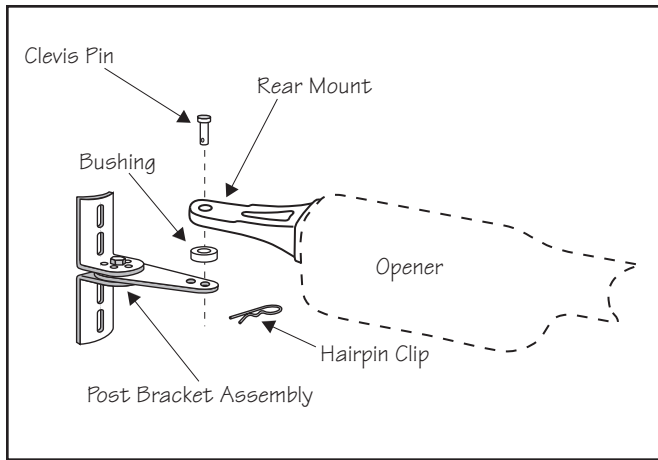

## Step 3

With the gate in the open position (up to 110° from its closed position), **and the opener fully retracted**, adjust the post bracket assembly and gate bracket until the opener is level. While holding the opener level, use C-clamps to **temporarily** keep the post bracket assembly and gate bracket in their respective positions on the fence post and gate.

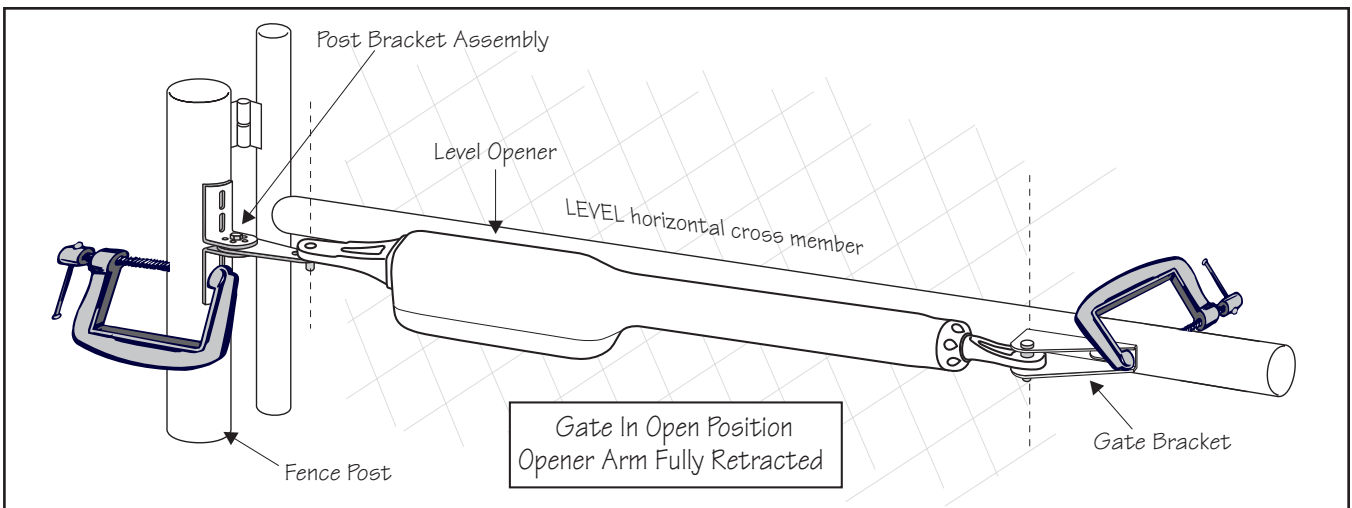

**IMPORTANT:** While determining the mounting point for the post pivot bracket assembly, be sure that the position allows for minimum 2 inches of clearance between the gate and the opener in both the open and closed positions, as shown in the diagrams below. This clearance will give the opener the most efficient leverage point for opening and closing the gate and more importantly provides the least possible pinch area.

## Step 4

When you feel that you have the best position for the post pivot bracket in the open position, insert the 5/16" bolt through the aligned holes of the post bracket and post pivot bracket to hold it in place. Remove the clevis pin from the front mount and while supporting the gate opener, swing the gate and gate opener to the closed position. With the gate and gate opener in the closed position check the clearance and be sure that the gate opener is not binding at the post pivot bracket.

If you don't have 2 inches of clearance or the gate opener is binding on the post pivot bracket, remove the 5/16" bolt and readjust the pivot bracket until you can achieve these important clearances. Reinstall the bolt and related hardware as shown in Step 1.

With the post pivot bracket in the optimum position for clearance and freedom of movement while maintaining 19 inches or less on the stroke. Reattach the opener to the gate bracket in the open position and recheck the gate opener level and make sure the brackets are clamped securely.

If you are mounting to a post or column larger than 8" or you can not achieve the mentioned clearances, you can:

- 1) eliminate the post pivot to try and achieve the proper clearances.
- 2) install the unit as a push to open (bracket not included).
- 3) re-hang the gate within 4" inches of the back corner of the column.

**NOTE:** Re-hanging the gate, depending on the construction of a column, may require additional expertise and tools/materials.

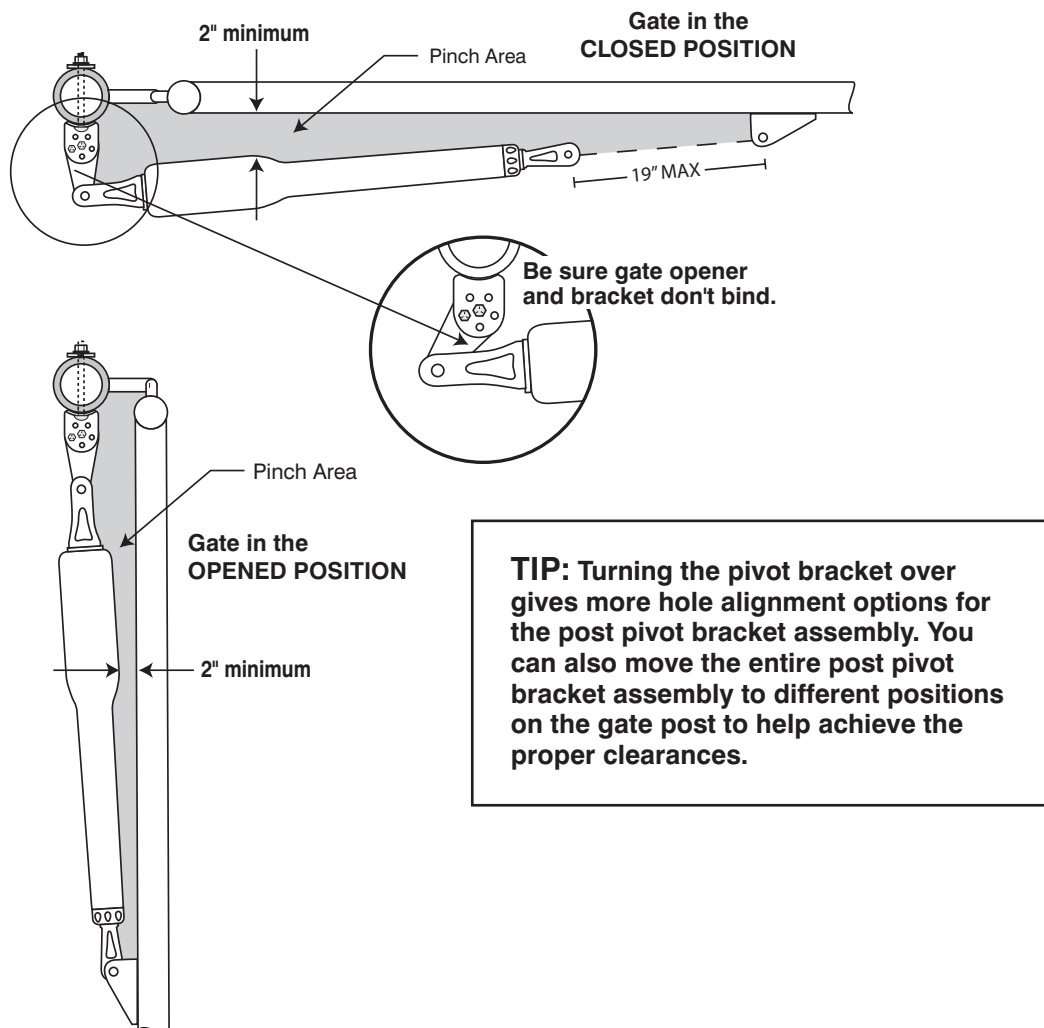

# Installing the Post Bracket Assembly and Gate Bracket

## Step 1

Mark reference points for bolt holes on the fence post through middle of bracket slots. Mark reference points for bolt holes on the gate cross member through middle of gate bracket slots. Marking reference points in this manner allows room for adjustment when mounting the post bracket assembly and gate bracket. After marking your reference points, remove the opener and brackets from the fence and gate.

## Step 2

Drill  $\frac{3}{8}$ " holes into fence post as marked.

## Step 3

Fasten post bracket assembly to the fence post using (4)  $\frac{3}{8}$ " x 8" bolts, washers, lock washers, and nuts (provided).

**NOTE:** In cases where the fence post has a diameter larger than 6", **threaded rods or carriage bolts longer than 8"** (not supplied) must be used.

## Step 4

Drill  $\frac{3}{8}$ " holes into the gate cross member as marked or use muller clamps. Mount gate bracket using (2)  $\frac{3}{8}$ " x 2  $\frac{3}{4}$ " bolts, washers, lock washers, and nuts (provided).

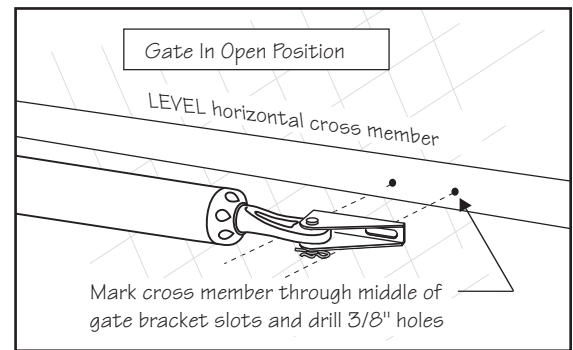
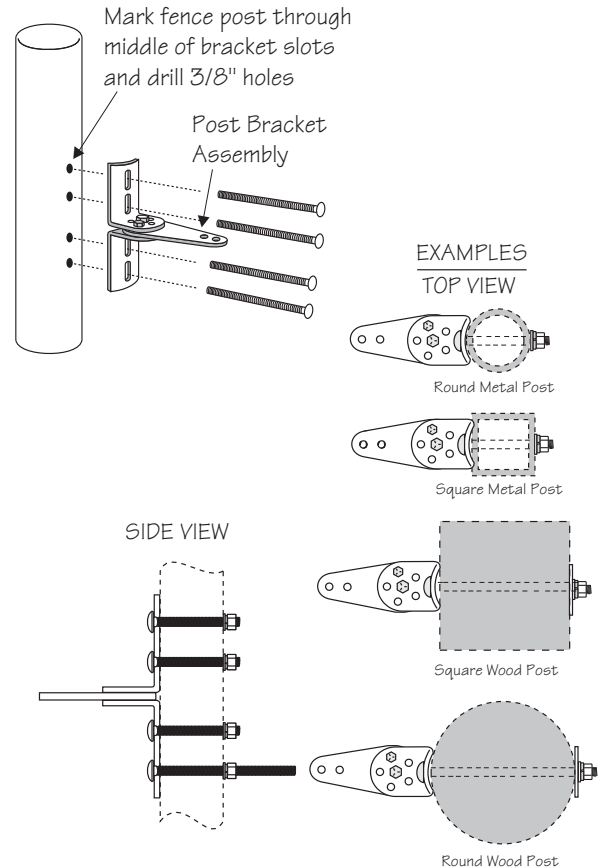

## Gate Bracket Mounting Examples

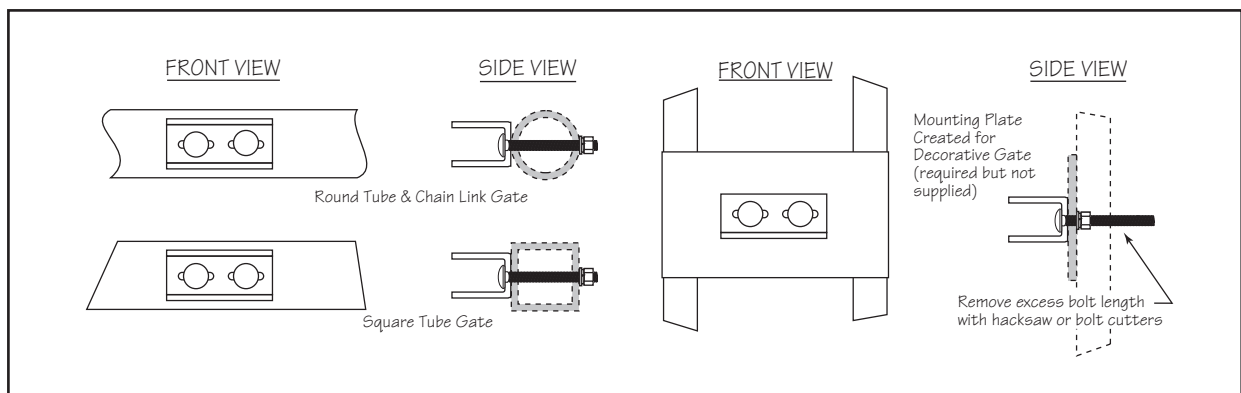

# MOUNTING THE OPENER

## Step 5

Attach the opener to the securely bolted post bracket assembly and gate bracket using clevis pins, bushings, and hairpin clips, or optional Pin Locks (FM133). Verify that the opener is level and adjust the post bracket assembly if necessary.

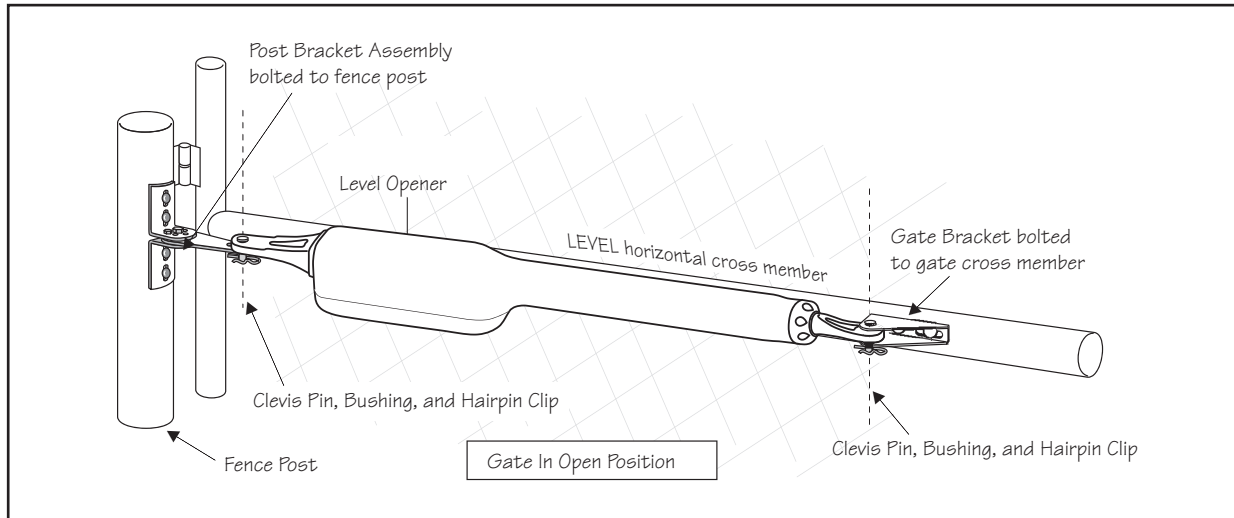

## Installation of the Closed Position Stop

The Mighty Mule Gate Opener firmly holds the gate in the closed position using the closed position stop plate. The closed position stop helps stabilize the gate leaf in the closed position.

NOTE: The stop plate will be mounted on the inside for a pull to open installation and on the outside for a push to open.

## Step 6

Remove hairpin, clevis pin, and washer from front mount and close the gate (remember to support opener). Fasten the *closed position stop plate* to the end of the gate frame on the **gate centerline**, but **do not** tighten it completely. Slide the stop plate toward the fence post until they touch (*see illustration*). Once you have moved the stop plate to the correct position, tighten its hardware completely.

Use the appropriate hardware for your type of gate (use U-bolts if you have a tube or chain link gate; wood or lag screws for wood gates; etc.). This hardware is not provided.

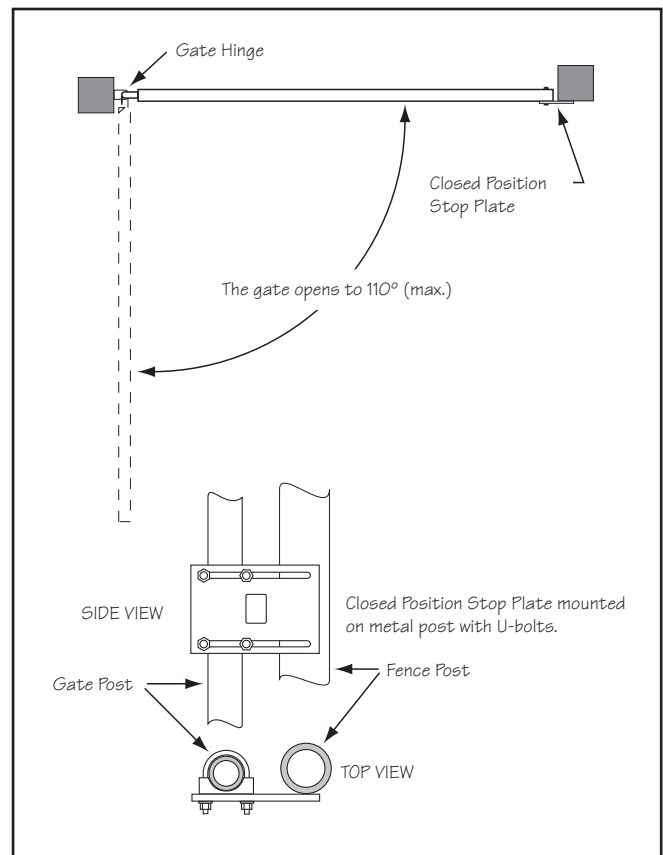



**At this stage of the installation, the opener should be reinstalled on an open gate and the closed position stop plate should be in place.**

## Check List

- The gate is plumb, level, and swings smoothly on its hinges.
- A plate or support was added for the gate bracket (if necessary).
- The opener is level and mounted on the centerline of the gate.
- Make sure all hardware is tightened at this time.

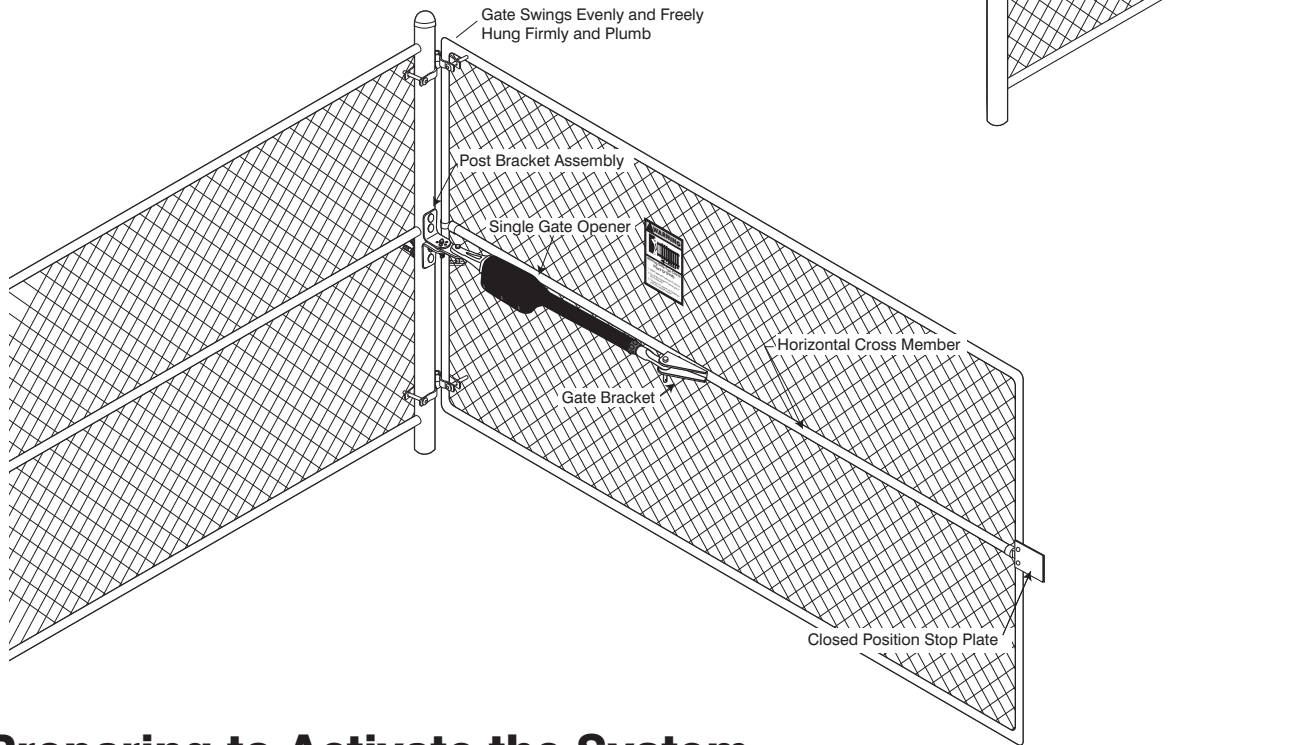

## Preparing to Activate the System

In order to have easy access to the control board during the rest of the installation, remove the opener and remount it upside down.

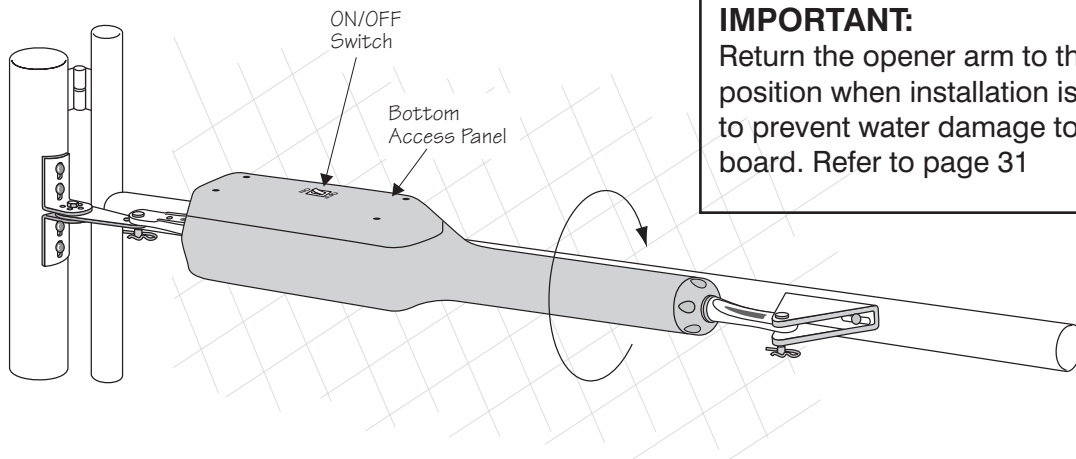

### **IMPORTANT:**

Return the opener arm to the upright position when installation is complete to prevent water damage to the control board. Refer to page 31

# CONNECTING THE BATTERY

## Step 1

With the opener mounted in the upside down position remove the Control Board Access Panel on the bottom of the opener arm.

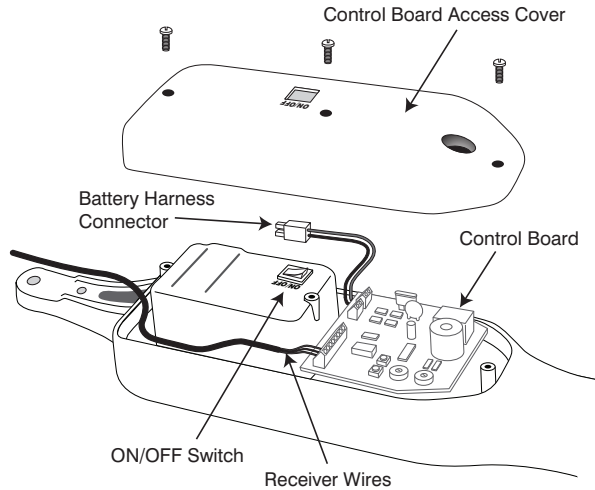
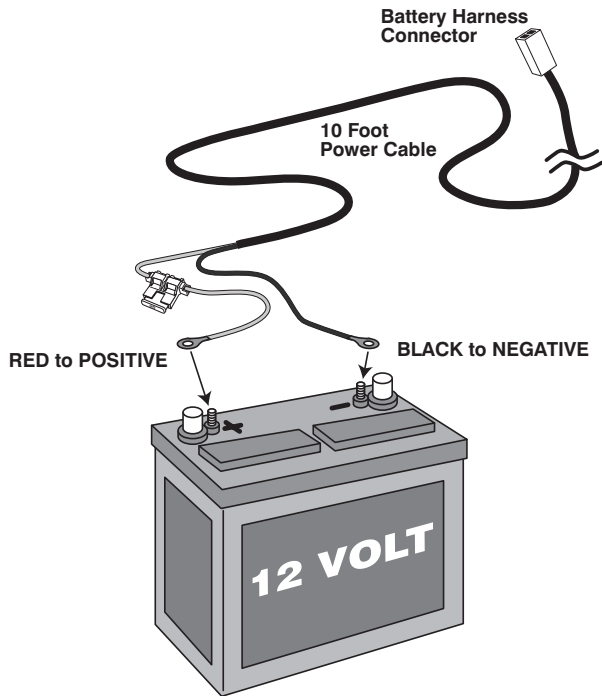

## Step 2

Place the 12 Volt automotive or marine type battery and its weatherproof case within 6 feet of the fence post where the opener arm is mounted.

## Step 3

Attach the 10 foot battery harness wires provided to the terminals of the battery.

**CAUTION:** Take care to attach the BLACK wire to the NEGATIVE terminal and the RED wire to the POSITIVE terminal. Reverse connection will cause damage to the control board.

## Step 4

**IMPORTANT:** Make sure the power switch on the opener arm is in the OFF position.

Run the plug end of the Wire Harness wire up to the opener arm and plug it into the battery harness connector coming from the control board.

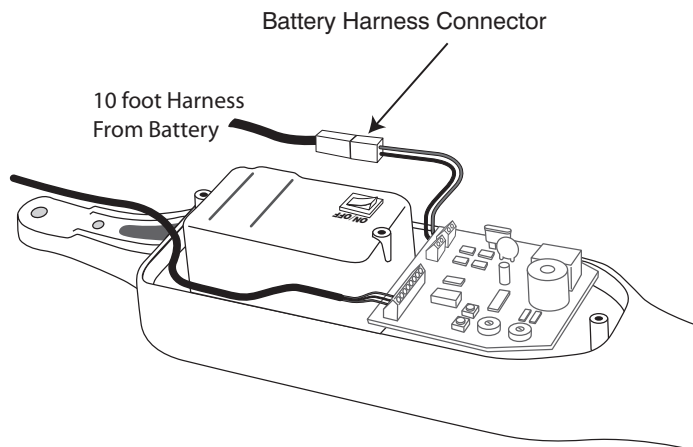

# IMPORTANT: Detailed Wire Routing Diagrams

The battery harness wire has an in-line fuse that must be placed inside the battery box when connecting the battery to the opener. The illustration to the right shows the best placement for the battery harness wire and connector inside the arm.

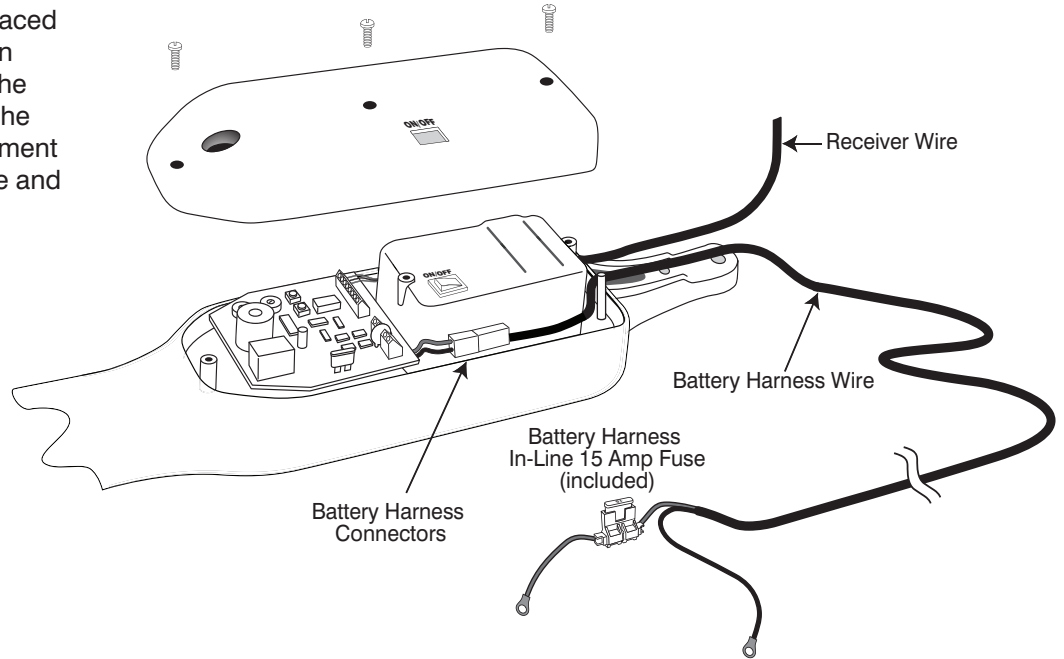

The wires from the battery harness, receiver, transformer or solar panel, and any accessories that have been installed will be routed down the sides of the opener and out the strain relief slot in the back of the opener.

It is **IMPORTANT** that the wires lay flat and run inside the routing pins at the back of the opener and out the strain relief slot without being pinched when the control board access cover is replaced. See the illustrations to the right and below.

## Wire Routing

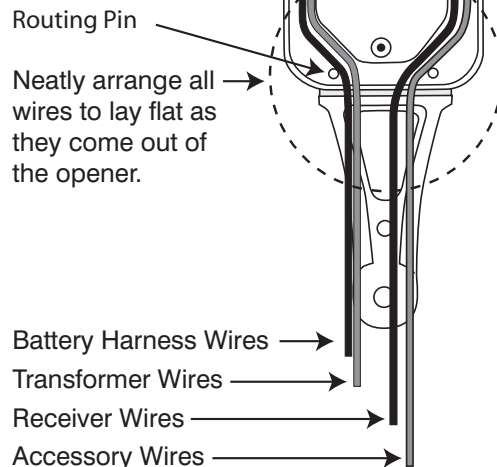

# CONNECTING THE TRANSFORMER

**IMPORTANT:** Never connect the transformer and a solar panel to the opener control board at the same time. It will damage the control board.

**IMPORTANT:** If you are using SOLAR PANEL(S) to charge the opener battery, skip this section and go to "Connecting Solar Panel(s)" section on page 24.

## IMPORTANT INFORMATION ABOUT LOW VOLTAGE WIRE

The only wire acceptable for use with GTO products is 16 gauge dual conductor, stranded, direct burial wire. This particular gauge enables the transformer to provide an adequate charge through the control board to the battery at distances up to 1000 ft.

**DO NOT** use telephone wire or solid core wire. Unlike stranded wire, these types of wire are inadequate for use with your gate opener system.

**NEVER SPLICE WIRES.** Splicing permits corrosion and seriously degrades the wire's ability to carry an adequate current.

## Step 5

Select the 120 Volt electrical outlet into which you will plug the transformer. Lay the low voltage wire in a trench following a path from the selected electrical outlet to the opener arm. Wires coming up from the ground should be run through PVC conduit to protect them from lawn mowers, weed eaters, and grazing animals. Be sure to bury the wire laid in the trench.

## Step 6

Bring enough wire up through the PVC conduit to allow for gate movement from open to closed position. See example at right.

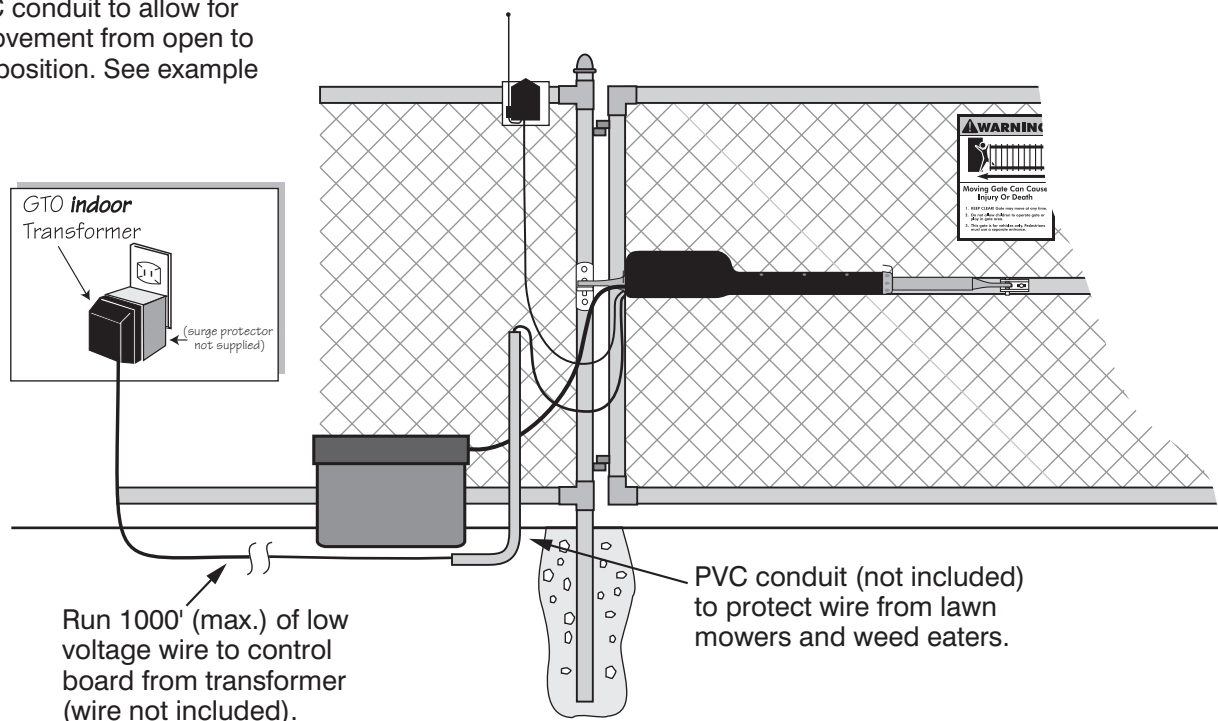

## Step 7

Strip  $\frac{3}{16}$ " off the ends of the low voltage transformer wire and twist tightly. Insert these ends to the **18 VAC** terminal block located on the control board (see illustration at right).

**Be certain not to let the exposed wires touch each other!**

Tighten set screws against exposed end of wires.

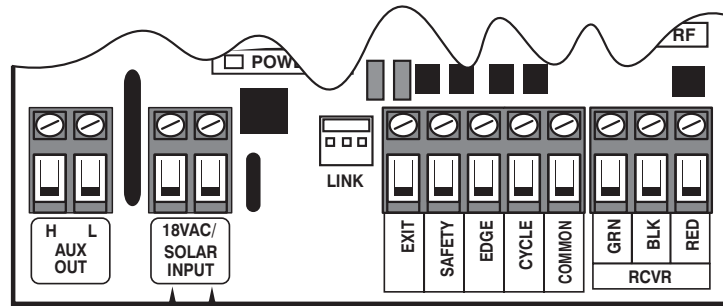
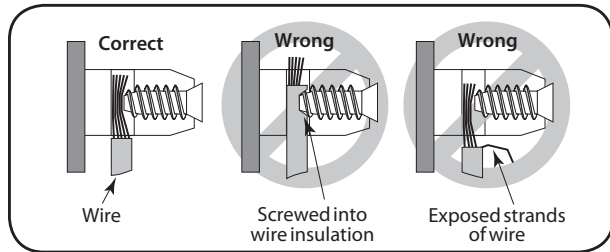

NOTE: The Mighty Mule power input is not polarized. The wires can be inserted into either terminal regardless of color.

Low Voltage Wire from Transformer

## Step 8

At the transformer ends of the transformer wires, strip  $\frac{1}{2}$ " of insulation from the ends of the low voltage wire. Attach these stripped ends to the transformer terminals.

**Make sure the exposed wires do not touch each other!**

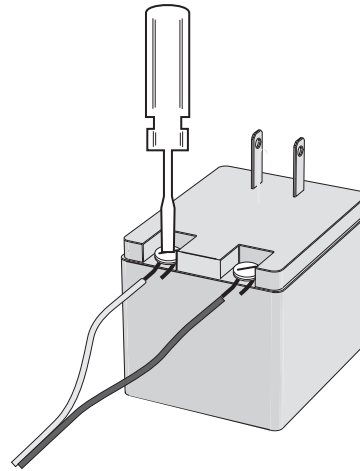

## Step 9

Plug the transformer into the electrical outlet. Use of a surge protector with the transformer is **strongly** recommended. If electrical outlet is located outdoors, outlet and transformer should be protected by a weatherproof cover.

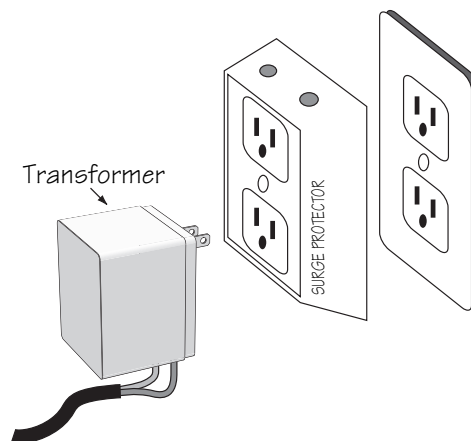

# CONNECTING THE SOLAR PANEL(S)

**IMPORTANT:** Never connect the transformer and a solar panel to the opener control board at the same time. It will damage the control board.

If you are using the transformer included with the Mighty Mule Gate Opener to charge the opener battery, skip this section and go to "CONTROL BOARD SETTINGS" below.

Strip  $\frac{3}{16}$ " off the ends of the low voltage wire from the solar panel and twist tightly. Insert these ends to the **18 VAC** terminal block located on the control board (see *illustration at right*). The wires can be inserted into either terminal regardless of color. **Be certain not to let the exposed wires touch each other!**

Tighten set screws against exposed end of wires.

**NOTE:** For multiple panels wire the panels in parallel as shown in this diagram.

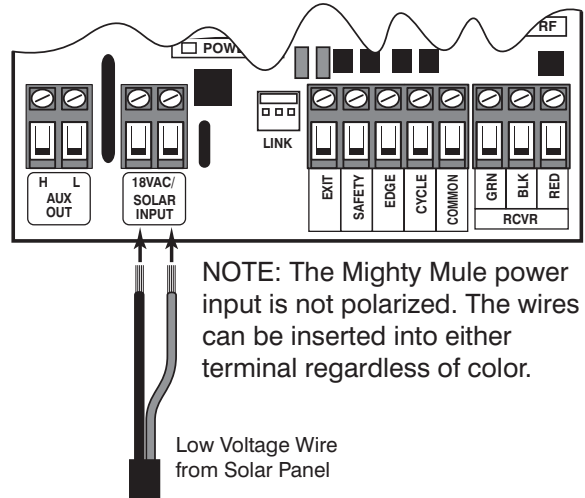

## Solar Panels connect in PARALLEL

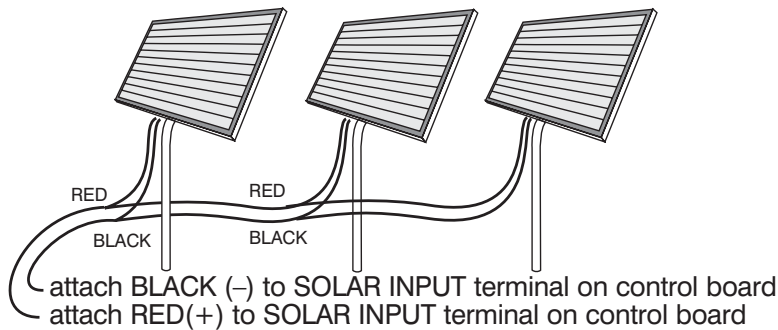

# CONTROL BOARD SETTINGS

## DIP Switches

### DIP Switch #1 - Push/Pull-to-Open

If your gate opens into the property (**Pull-to-Open**) the DIP Switch is set to **OFF** (factory). If your gate opens out from the property (**Push-to-Open**) the DIP Switch must be set to the **ON** position.

**NOTE:** if you have a Push-to-Open gate application see Push-to-Open Instructions on page 32.

### DIP Switch #4 - Lock/Beacon

This DIP selects the mode of operation of the "AUX OUT" terminal.

The **OFF** (factory setting) position is selected if you are using an **Automatic Gate Lock** with your Mighty Mule Opener.

(Refer to page 30, AUX/OUT Accessory Connection)

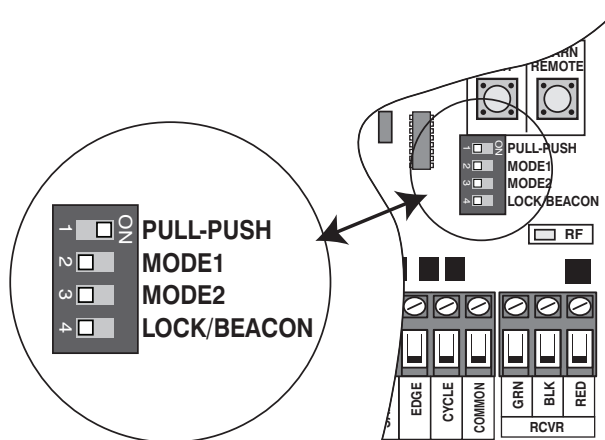

# MOUNTING THE RECEIVER

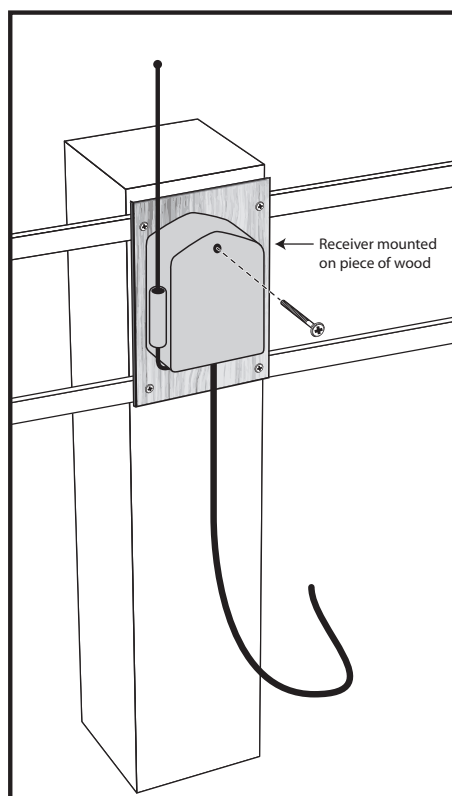

Use the transmitter to check the range of the receiver **before permanently mounting it**.

Consider the following when mounting the receiver:

- Standard receiver cable length is 10 feet (receivers with a longer cable are available as special order items; *call the GTO Sales Department*). NEVER splice receiver cable!
- DO NOT run cable in conduit containing ac wiring.
- The receiver range can vary from 50 to 100 feet depending upon weather, topography, and external interference.

**NOTE: Do not mount upside down.**



# SETTING THE CLOSED POSITION LIMIT

## Setting the Closed Position Limit

For PULL-TO-OPEN Installation

Turn the power switch on to the **ON** position



### Step 1

Power switch is on, gate is in the **OPEN** position, opener arm fully retracted.

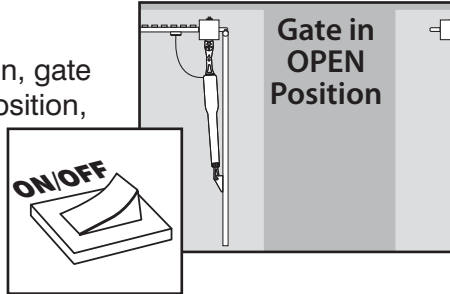

### Step 2

Press the transmitter to activate opener arm. The gate will begin to **CLOSE**.

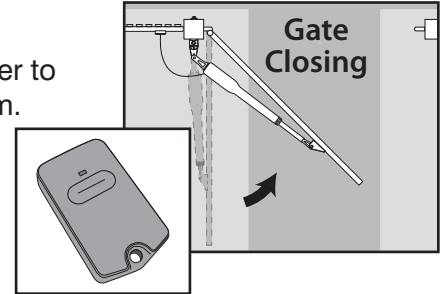

**NOTE:** If gate stops and reverses you may need to adjust the Stall Force (see page 27).

**NOTE:** All transmitters come pre-programmed from the factory. However, if the transmitter did not activate the gate, follow steps 1 to 3 on page 28.

### Step 3

When the gate reaches the desired **CLOSED** position, press the transmitter to stop the gate.

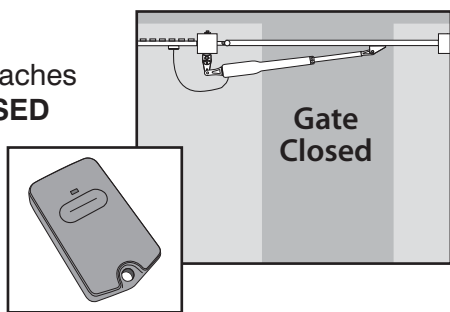

### Step 4

With the gate at the correct position, program the closed limit setting by pressing and holding SET LIMIT for 5 seconds.

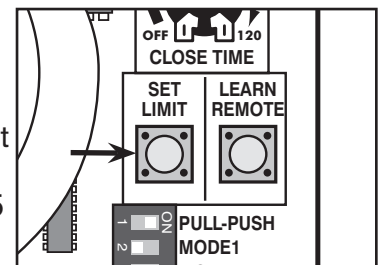

### Step 5

Press the transmitter again to allow the gate to return to the fully **OPEN** position.

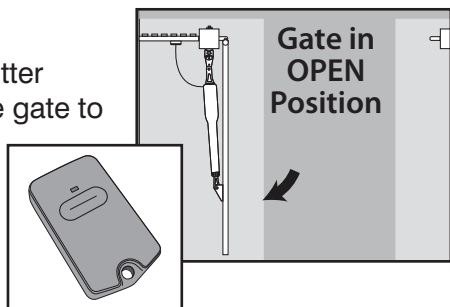

The gate closed position is now programmed.

If you set the limit at the wrong position: press your transmitter to return the gate to the fully opened position, then press and hold the SET LIMIT button for 5 seconds. This will clear the memory for the closed limit position. Repeat Steps 1-5.

# Setting Dual Sense Detection and Auto Close Timer

Do not use the Dual Sense Stall Force adjustment to compensate for a gate that is sticking or binding. Excessive Stall Force may cause damage to the gate operator or gate system or Injury or Death.

The Stall Force adjustment controls the amount of force the opener will apply against an obstruction before it stops and reverses direction. The adjustment on the control board operates like a volume control on a radio. It controls the amount of force the opener will apply to an obstruction before it automatically reverses direction.

The Stall Force adjustment is located on the control board. Turn the "STALL FORCE" arrow in the center of the potentiometer with small flat head screwdriver. Adjust the sensitivity from the MINIMUM position up to the point where the gate operates without obstructing from its own weight or the wind conditions in your area.

**NOTE:** You may need to increase the stall force in cold weather due to increased resistance from gate hinges. However, the adjustment must remain as near to minimum as possible and when the weather improves decrease the setting to the appropriate position.

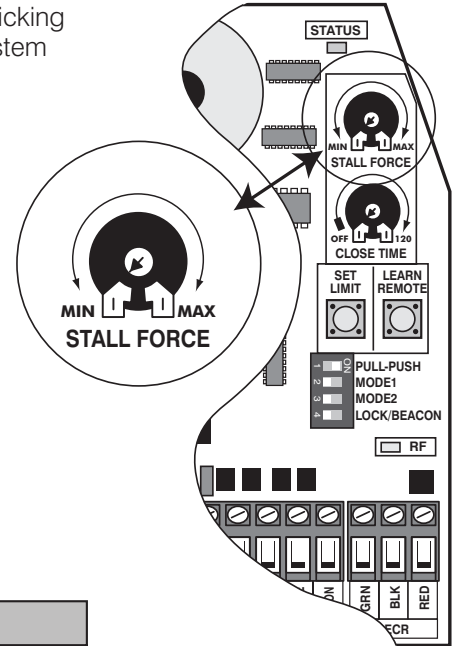

## CAUTION

For safety reason the Dual Sense Stall Force setting on the Mighty Mule control board comes from the factory set at MIN (minimum). This setting may need adjustment depending on the size and weight of the gate.

**ALWAYS KEEP SAFETY AT THE TOP OF YOUR LIST WHEN ADJUSTING OR SERVICING YOUR GATE SYSTEM.**

## Set Auto-Close Time

The Auto-Close determines how long the gate will remain open before it automatically closes. The factory setting is OFF. Use a small flat blade screwdriver, you can adjust the settings to OFF, or from 3 to 120 seconds.

**NOTE:** Auto-Close timer is disabled (gate will not automatically close) if gate is not at the fully open position.

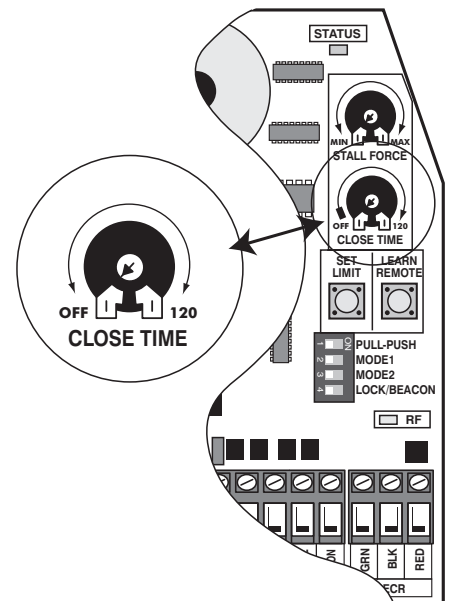

# PERSONALIZE YOUR TRANSMITTER SETTING

All GTO transmitters have a standard setting and are ready to operate your Mighty Mule Gate Opener. For your safety and security, we strongly recommend that you replace the factory setting with your own personal setting.

NOTE: If you have multiple transmitters, you should adjust all of them at this time. All transmitters should have the same DIP switch setting.

## Step 1

Use a small phillips head screw driver to remove the transmitter cover.

## Step 2.

Set the transmitter DIP switches using a small screwdriver. There are nine (9) transmitter DIP switches; each can be placed in three different positions (+, 0, -). DO NOT set all the switches in the same position, such as all +, all 0, or all -. Once the DIP switches have been reset, replace and close the access cover.

WARNING: No other adjustments should be made inside the transmitter.

## Step 3.

Program the new setting in the control board memory.

- A. Press and hold transmitter button.
- B. Press and hold the LEARN REMOTE button on the control board until it beeps. (3-5 seconds)
- C. Release transmitter button.
- D. Release LEARN REMOTE button. The new code is stored in control board memory.

Your other transmitters that have the same switch setting will now be operational.

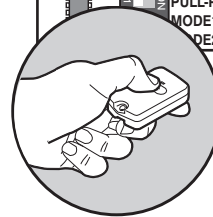
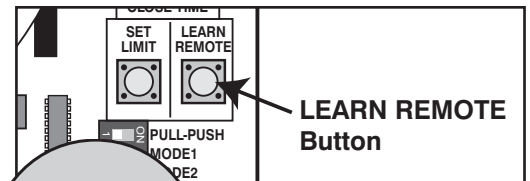
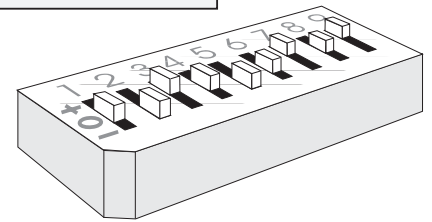
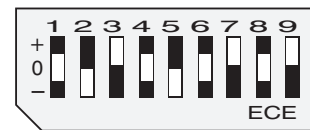
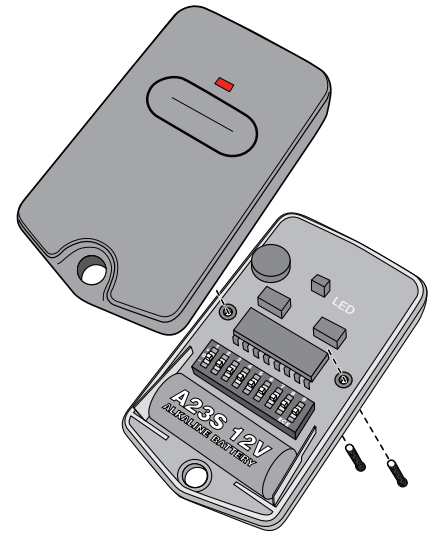

**WARNING:** Changes, modifications or adjustments not expressly approved by GTO Access Systems, LLC could void the user's authority to operate this equipment. There Are No User Serviceable Parts.

NOTICE: This equipment has been tested and found to comply with the limits for a Class B digital device, pursuant to part 15 the FCC. These limits are designed to provide reasonable protection against harmful interference in a residential installation. This equipment generates, uses and can radiate radio frequency energy and, if not installed and used in accordance with the instructions, may cause harmful interference to radio communications. However, there is no guarantee that interference will not occur in a particular installation. If this equipment does cause harmful interference to radio or television reception, which can be determined by turning the equipment off and on, the user is encouraged to try to correct the interference by one or more of the following measures:

- Reorient or relocate the receiving antenna.
- Increase the separation between the equipment and receiver.
- Connect the equipment into an outlet on a circuit different from that to which the receiver is connected.
- Consult the dealer or an experienced radio/TV technician for help.

This device complies with Part 15 of the FCC Rules. Operation is subject to the following two conditions: (1) This device may not cause harmful interference, and (2) this device must accept any interference received, including interference that may cause undesired operation.

# CONNECTING ACCESSORIES

## Before You Begin

Mighty Mule strongly recommends the use of additional obstruction detection devices however we do not endorse any specific brand names. Only use products that are listed to be in compliance with any applicable UL safety standards and national and regional codes.

PLEASE NOTE: Contact sensors, non-contact sensors, shadow loops, etc. are not included with the Mighty Mule. Refer to the sensor manufacturer's instructions for information about installing accessory devices.

**Mighty Mule gate openers ONLY accepts accessory devices with normally open dry contact outputs.**

## ⚠ WARNING

Make sure the operator power switch is turned OFF before connecting ANY device wiring to the terminals of the controller. Unplugging the transformer does not turn power to the operator off.

## Input Connections

- All control inputs are dry-contact, normally open, inputs. DO NOT apply external voltage sources to these inputs.
- All inputs are connected with respect to COMMON terminal.
- The status LED will blink once when any input is activated.

- 1 COMMON:** Circuit common (reference for all logic input)
- 2 CYCLE:** (Typically for use with push button or hard-wired keypad)
  - Each activation at this input will cycle the operation as follows:  
OPEN–STOP–CLOSE–STOP–OPEN
- 3 EDGE:** (Typically for use with safety edge device)
  - Activation of this input while the gate is closing or opening will cause the gate to stop and reverse direction for approximately 2 seconds.
  - Activation of this input while gate is idle will prevent gate from opening or closing.
- 4 SAFETY:** (Typically for use with photo beam device, loop detector or other non-contact sensors)
  - Activation of this input while the gate is closing will cause the gate to stop and return to the opened position.
  - Activation of this input while the gate is opening has no effect (gate will continue to open).
  - Activation of this input while gate is idle will prevent gate from closing.
- 5 EXIT:** (Typically for use with exit loop or wand)
  - Activation of this input will open the gate if it's not already at the open position
  - Activation of this input while at open limit will restart the auto close time (if enabled) and hold the gate open if the contact is maintained.

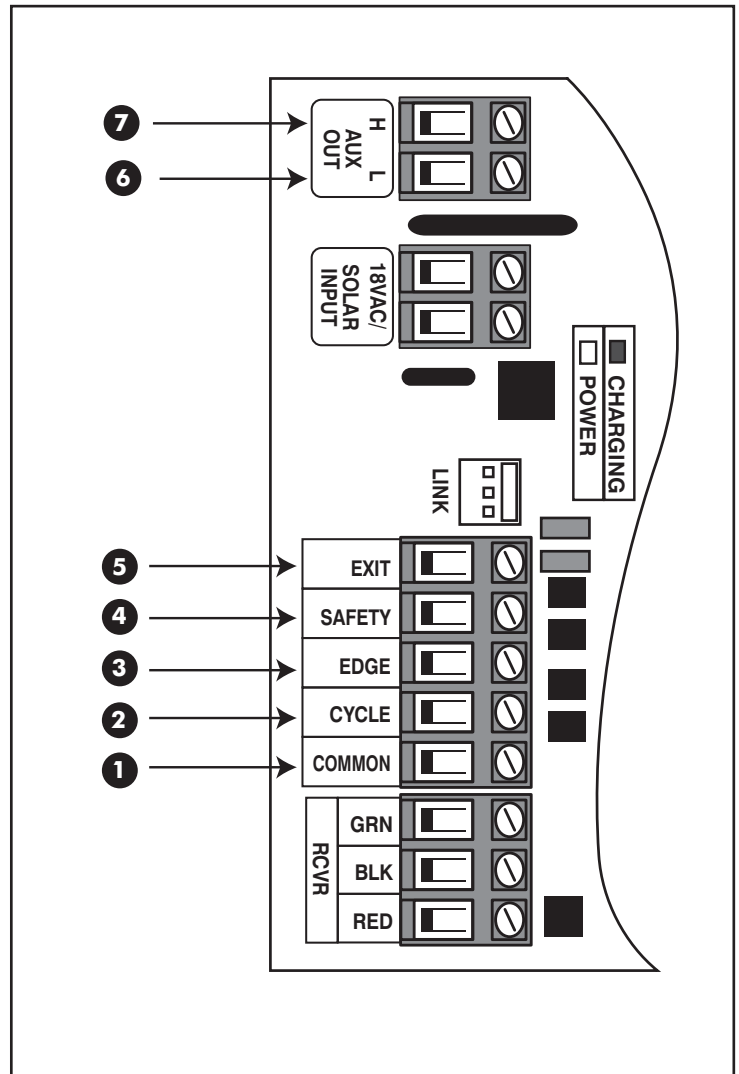

**6/7 AUX/OUT:** Multi-function output: refer to pages 30 and 31.

# WIRING ACCESSORIES

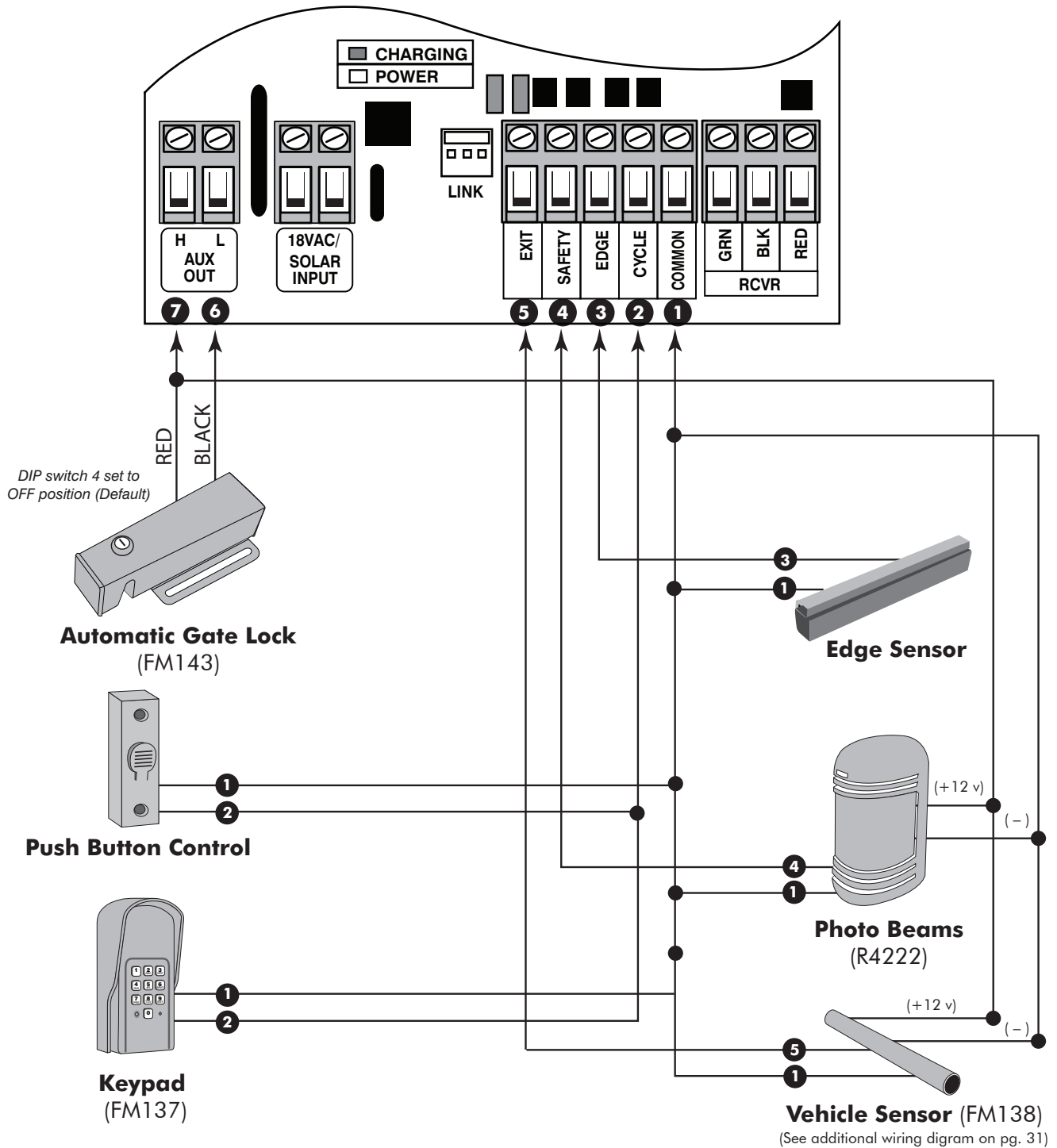

**NOTE:** Connections are for typical applications. For additional connection options not illustrated here refer to the accessory manual for details.

# Mighty Mule Gate Opening Sensor (FM138)

The Gate Opening Sensor is designed for residential and agricultural applications and is compatible with Mighty Mule automatic gate openers. The Sensor is an electromagnetic sensor, which offers 'hands free' operation of the Mighty Mule Gate Opener with a 12 ft. radius of detection of vehicles in motion.

**Make sure the power switch to the opener is turned OFF before connecting sensor wiring to the Mighty Mule 360 terminal blocks.**

The wiring cable that comes with the Mighty Mule Gate Opening Sensor has four colored wires and a braided wire shield around them and is factory pre-paired for installation.

Connect the twisted SHIELD and other bare wire, the YELLOW, the BLACK as well as a separate length of wire, with a WIRE NUT. The other end of the single length of wire is connected to the COMMON terminal on the Mighty Mule control board.

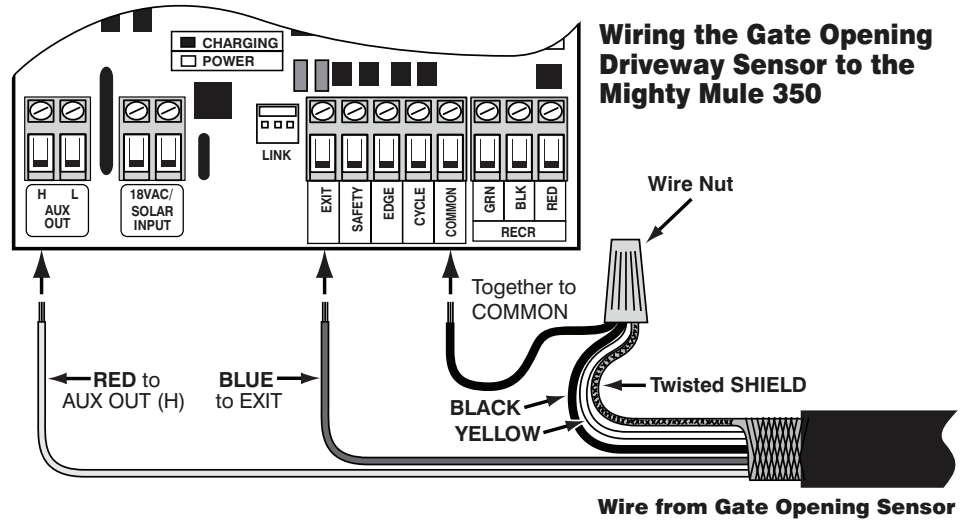

Connect the RED wire from the sensor to the AUX OUT (H) terminal, and the BLUE wire to the EXIT terminal on the Mighty Mule control board.

**NOTE:** If you need to change the length of the cable: Cut the cable to length. Strip back a few inches of the black outer cover to expose the braided shield. Cut the shield down one side and twist as shown in the illustration.

## FINAL STEPS

### When everything has been connected to the opener...

Replace the control board access cover. Remove the opener arm from both mounts and remount it in the upright position (control board cover facing down). Failure to re-mount opener in the upright position will allow water to enter the opener and cause damage to the opener control board.

- Attach Warning Signs
- Trim all Bolts
- Register Your Warranty

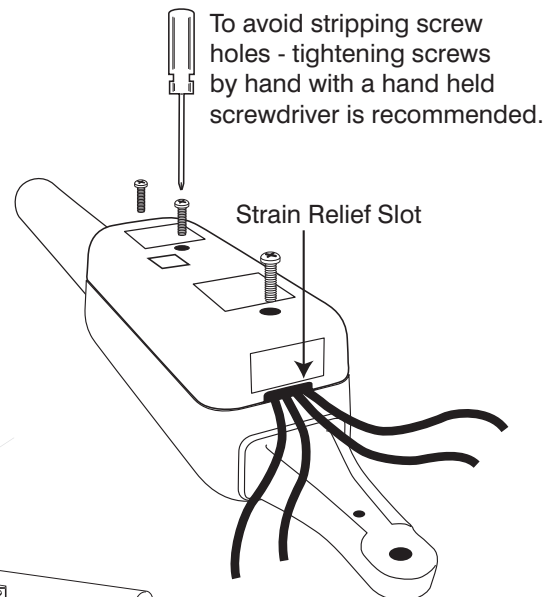
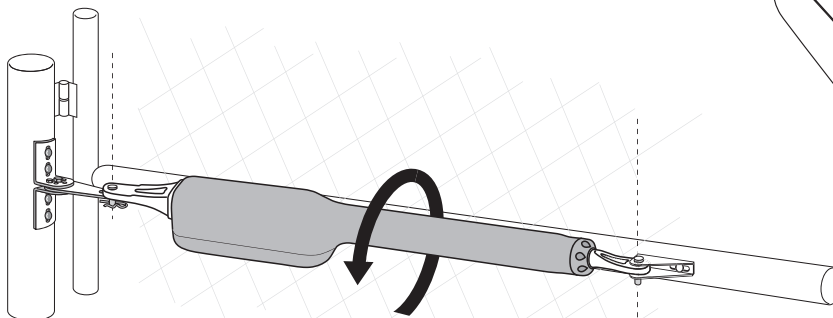

# PUSH-TO-OPEN INSTALLATION INSTRUCTIONS

**PUSH-TO-OPEN** gates open out from the property (opener arms *extend* to open). A Push-To-Open Bracket is required for this type of installation. In a Push-To-Open installation, the opener is installed while the gate is **in the closed position and the opener fully retracted**.

Swinging gates **MUST NEVER** open into public access areas!

## Step 1

Insert the 3/8" x 2" bolt through the center hole of the post brackets and post pivot bracket as shown. Fasten a 3/8" lock washer, 3/8" washer and 3/8" nut on the end of the bolt. **DO NOT over tighten** the nut because the post pivot bracket will have to be adjusted later.

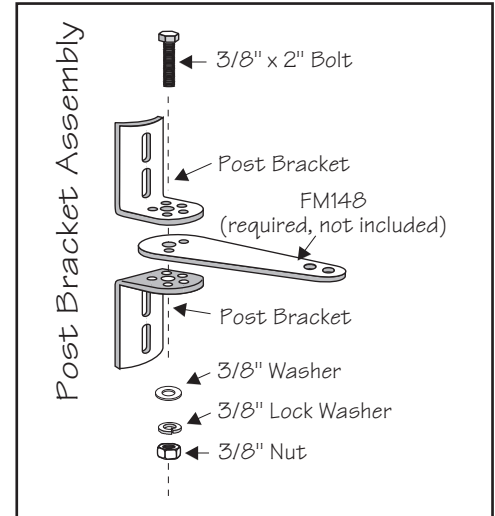

## Step 2

Attach post bracket assembly and gate bracket to the opener with the clevis pins and bushings. Secure the clevis pins with hairpin clips.

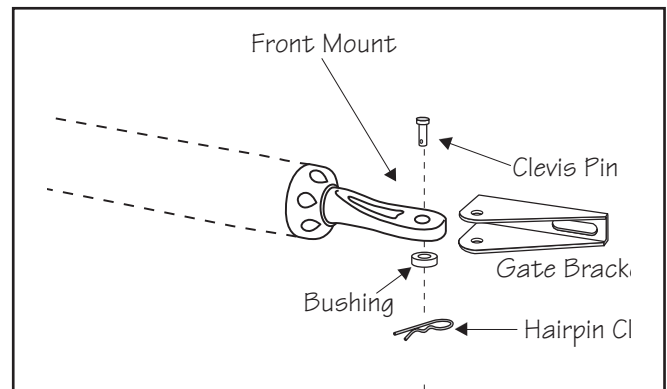
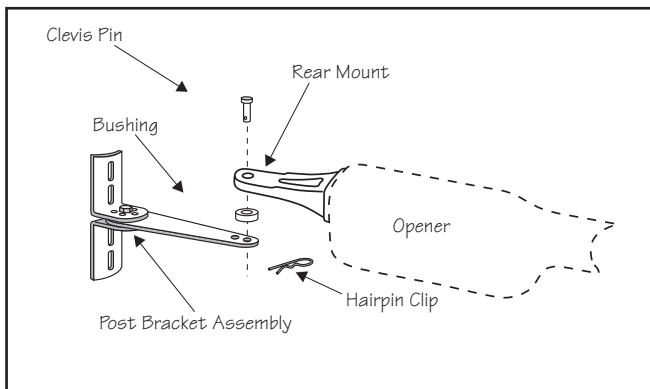

## Step 3

With the gate in the closed position (up to 110° from its open position), **and the opener fully retracted**, adjust the post bracket assembly and gate bracket until the opener is level. While holding the opener level, use C-clamps to **temporarily** keep the post bracket assembly and gate bracket in their respective positions on the fence post and gate.

**IMPORTANT:** While determining the mounting point for the post pivot bracket assembly, be sure that the position allows for minimum 2 inches of clearance between the gate and the opener in both the open and closed positions, as shown in the diagrams below. This clearance will give the opener the most efficient leverage point for opening and closing the gate and more importantly provides the least possible pinch area.

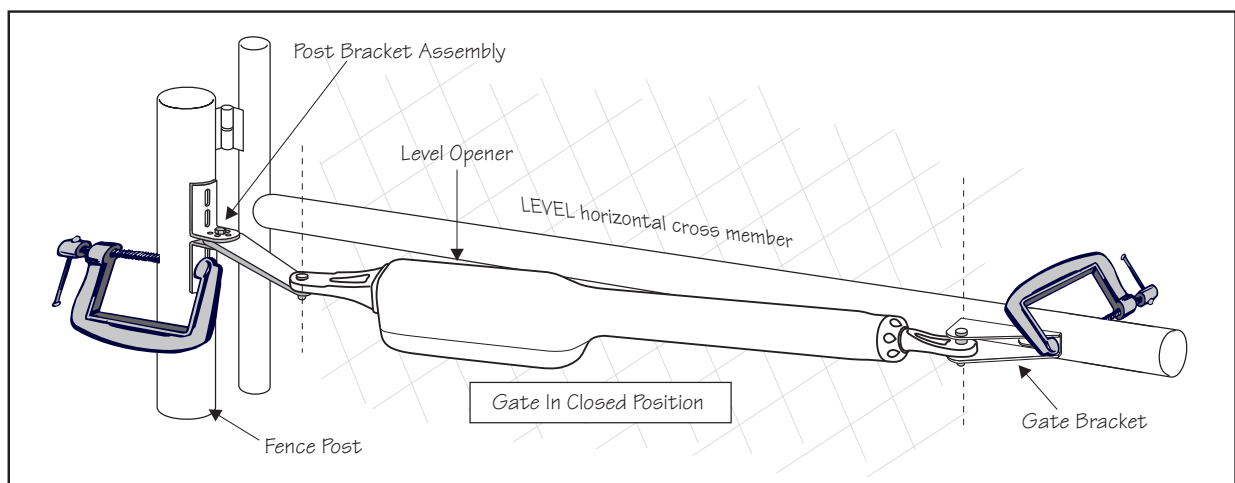



## Step 4

When you feel that you have the best position for the post pivot bracket in the closed position, insert the 5/16" bolt through the aligned holes of the post bracket and post pivot bracket to hold it in place. Remove the clevis pin from the front mount and while supporting the gate opener, swing the gate and gate opener to the open position. With the gate and gate opener in the open position check the clearance and be sure that the gate opener is not binding at the post pivot bracket.

If you don't have 2 inches of clearance or the gate opener is binding on the post pivot bracket, remove the 5/16" bolt and readjust the pivot bracket until you can achieve these important clearances. Make sure to reinstall the bolt and related hardware as shown in step 1.

With the post pivot bracket in the optimum position for clearance and freedom of movement while maintaining 19 inches or less on the stroke. Reattach the opener to the gate bracket in the open position and recheck the gate opener level and make sure the brackets are clamped securely.

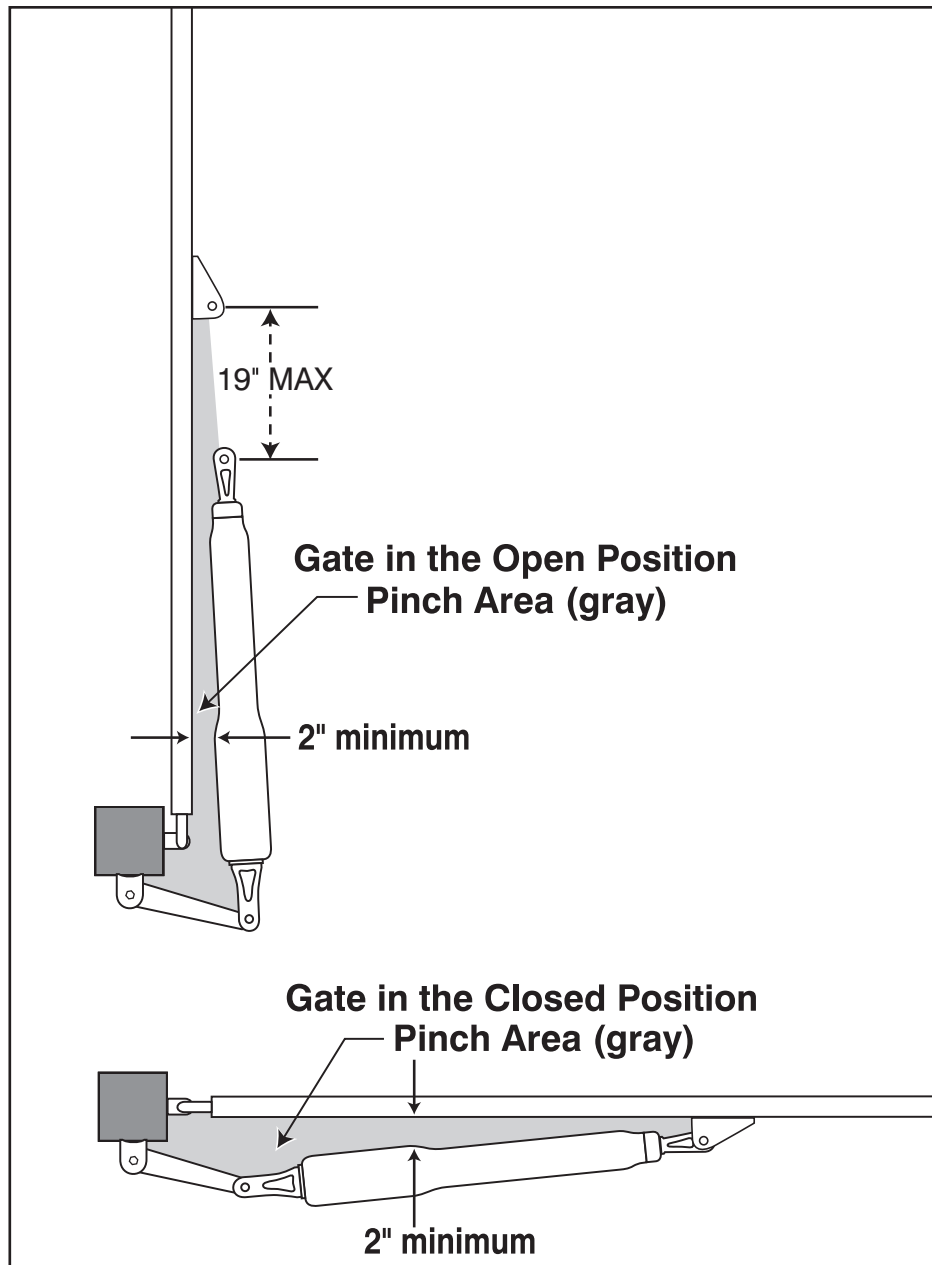

# Set Control Board for Push-To-Open

NOTE: Before setting the limits for push-to-open, follow the instructions on page 17 to 25 to complete the installation.

Make sure the control box power switch is OFF. Use a small screwdriver to move the Number 1 DIP switch from the factory setting (OFF / Pull-To-Open) to ON for Push-To-Open. Turn power switch ON. The control board is now configured to push the gate open.

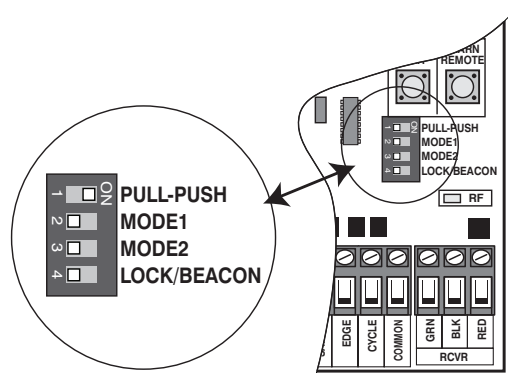

## Setting the Open Position Limit (Push-To-Open Installations)

### Step 1

Power switch is on, gate is in the **CLOSED** position, opener arm fully retracted.

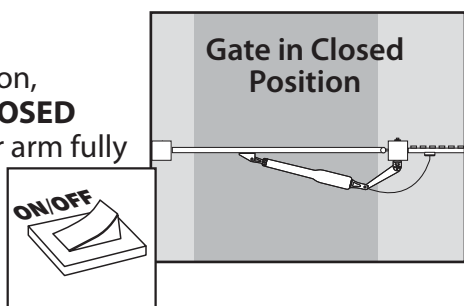

### Step 2

Press the transmitter to activate opener arm. The gate will begin to **OPEN**.

**NOTE:** If gate stops and reverses you may need to adjust the Stall Force (see page 27).

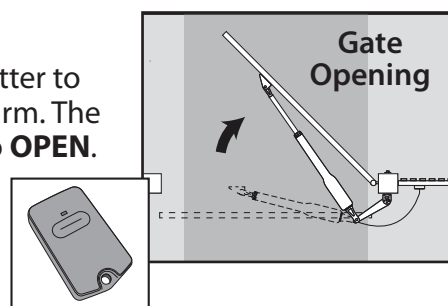

**NOTE:** All transmitters come pre-programmed from the factory. However, if the transmitter did not activate the gate, follow steps 1 to 3 on page 28.

### Step 3

When the gate reaches the desired **OPEN** position, press the transmitter to stop the gate.

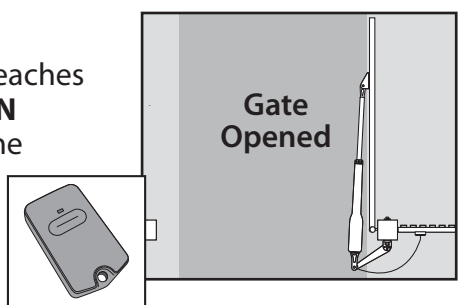

### Step 4

With the gate at the correct position, program the open limit setting by pressing and holding SET LIMIT for 5 seconds.

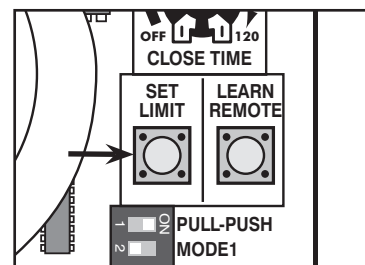

### Step 5

Press the transmitter again to allow the gate to return to the fully **CLOSED** position.

Gate is now programmed

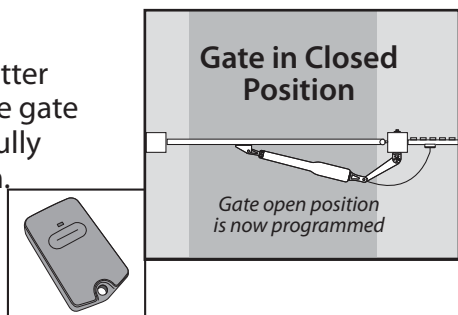

The gate open position is now programmed. If you set the limit at the wrong position: press your transmitter to return the gate to the fully closed position, then press and hold the SET LIMIT button for 5 seconds. This will clear the memory for the open limit position. Repeat Steps 1-5.

# MAINTENANCE

Monthly, test the obstruction and entrapment protection systems.

Monthly, service the gate operator (make sure the power switch is OFF). Clean extended operator arm with a soft, dry clean cloth. After cleaning, apply a high quality silicon spray to a soft dry cloth and wipe the push/pull tube. DO NOT directly spray the tube!

On all gates weighing 250 lb. or more, routinely grease the ball bearing hinges at least 4 times a year; more frequently if the gates are near a coastal area.

Monthly, turn off the power switch and disconnect the Mighty Mule and move the gate to make sure the gate is moving freely without sticking or binding. Lubricate the hinges or repair the gate as required before reattaching the Mighty Mule.

Monthly, check the gate system for potentially entrapments from new landscaping or construction. Eliminate or guard as required.

Monthly, check that the warning signs are mounted on each side of the gate and clearly visible. Replace the signs if they are missing or damaged.

Replace batteries every 2-3 years and properly recycle old batteries.

# TROUBLESHOOTING GUIDE

## AUDIBLE/BUZZER/ALARM FEEDBACK:

### 1. 1 beep with 2 seconds pause and repeats:

Limit switch error: Limit switch's normally open and normally closed inputs both open or both shorted. The alarm will automatically shut off in 4 seconds after the problem is corrected.

### 2. 5 beeps with 2 seconds pause and repeats:

Low battery condition detected: Low battery can occur if the following condition is detected:

While in idle state and the battery voltage is below ~11.5 Volts.

While running and the battery voltage is below ~10.0 Volts.

The alarm will automatically shut off when the idle voltage is more than 12 Volt.

The unit may continue to operate even when low battery is detected.

The STATUS LED will also blink when the buzzer is beeping.

Check power connections.

Test the transformer or solar panel and test the battery.

### 3. 1 beep when attempting to run the unit:

No battery is connected.

Blown fuse.

Dead cell or extremely low battery condition; test the battery.

### 4. Alarm continuously beeps (Transmitter does not operate unit AND not at either limit):

Two consecutive obstructions have been detected without reaching the limit. Alarm will automatically shut off after 5 minutes. 'Power-cycle' the unit will also shut off the alarm.

Check the gate for level and plumb and make sure the gate path is clear. See adjustments on page 27.

### 5. Power-Cycle:

The alarm will beep for 1 second upon power up. This is a normal condition.

## VISUAL/LEDS FEEDBACK:

### 1. RF LED (LED2):

Blinking when there is 318 MHz signal is received. This LED is typically off when the receiver is connected and no 318 MHz signal is presented.

### 2. STATUS LED (LED1):

While the unit is IDLE:

1 blink with 2 seconds off:

Free Exit terminal is shorted to common.

2 blinks with 2 seconds off:

Safety terminal is shorted to common.

3 blinks with 2 seconds off:

Edge terminal is shorted to common.

4 blinks with 2 seconds off:

Cycle terminal is shorted to common.

Test the accessory that corresponds to the error code.

NOTE: Whenever there is a change in state at the inputs this LED will blink once.

### 3. POWER LED (Green):

ON: AC power or solar power is presented.

OFF: NO AC power or solar power is presented.

Check your charging source; transformer or solar panel.

### 4. CHARGING LED (Red):

Red light on or flashing – the unit is charging

Red light off – the unit is not charging. Check transformer or solar panel.

### THE GATE CLOSURES THEN OPENS PARTIALLY:

1. Check the position of the mounting brackets and readjust if necessary.
2. Check the gate for binding or hinge damage.
3. Increase **Stall Force** setting.

### THE GATE OPENS THEN CLOSURES PARTIALLY:

1. Check the position of the mounting brackets and readjust if necessary.
2. Check the gate for binding or hinge damage.
3. Increase **Stall Force** setting.

## VOLTAGE READINGS

18 Vac Transformer \_\_\_\_\_ 18.0 to 22.0 Vac

5 W Solar panel (single) \_\_\_\_\_ 18.0 to 22.0 Vdc  
measure voltage at panel and control box.

12 V Battery \_\_\_\_\_ 12.0 to 13.5 Vdc

Charging circuit \_\_\_\_\_ 12.0 to 14.8 Vdc  
measure voltage with battery connected

# WARRANTY REPAIRS

If your Mighty Mule Gate Opener is not operating properly, please follow the steps below:

1. First use the procedures found in the Visual and Audible Diagnostic Indicators section (page 35).
2. If you are unable to solve the problem, call the GTO Service Department at (800) 543-1236, or (850) 575-4144. Refer to the serial number (located under rear mount on arm) and date of purchase when calling for assistance.
3. **If repair or replacement of your gate opener is necessary, the Service Department will assign a Return Goods Authorization (RGA) number to you.**
4. Once you have received your RGA# send in your original equipment for repair. Please refer to Manufacturers' Limited Warranty for complete details. Securely pack the component(s) authorized for return to the factory. Include a copy of your sales receipt for the purchase of the product(s). Write the RGA number issued to you on the outside of the package in LARGE BOLD PRINT.

Ship the package(s) freight prepaid to: GTO, 3121 Hartsfield Road, Tallahassee, Florida, USA 32303.

**NOTE: Products returned to GTO without a Return Goods Authorization (RGA) number in LARGE BOLD PRINT on the outside of the package WILL NOT be accepted. Also, items returned to GTO freight collect WILL NOT be accepted.**

**After the twelve (12) month warranty expires, GTO, or one of its authorized service centers will perform necessary repairs for a nominal fee. Call GTO's Technical Service Department for more information.**

## GTO Technical Service and Installation Assistance

8:00am–7:00pm • Monday–Friday (EST)

Toll Free Support: 800-543-1236 • Fax: 850/575-8950



24/7 Troubleshooting Wizard: <http://support.gtoinc.com>

GTO Access Systems, LLC  
3121 Hartsfield Road, Tallahassee, Florida, USA 32303  
[www.mightymule.com](http://www.mightymule.com)



## ACCESSORIES

**Accessories are Available From Your Retail Store**

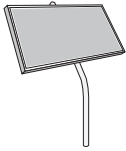

### **Solar Panel Kits [FM121/FM123]**

If your gate operator is more than 1000 ft. away from an AC power outlet, you can choose to maintain the battery charge with the GTO Solar Panel Kit.

- 10 Watt Solar Panel Charging Kit [FM123]
- 5 Watt Solar Panel Charging Kit [FM121]



### **Push Button Control [FM132]**

Unlit doorbell button for remote entry or exit control. Wires directly to the control board and uses 16 gauge stranded, dual conductor low voltage wire (sold separately).

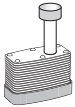

### **Pin Lock [FM133]**

Use as a substitute for the clevis pin at the front mount of the FM360 to prevent theft of the operator.



### **Key Chain Two Button Transmitter [FM134]**

The Key Chain Transmitter is a dual button version of the **Mighty Mule®** single button entry transmitter and has the same adjustable code settings. Used for 2 gates or 1 gate and garage door. (battery is included)



### **Single Button Transmitter [FM135]**

The **Mighty Mule®** entry transmitter, with adjustable code settings, is standard equipment with all **Mighty Mule®** systems. (battery is included)



### **Digital Keypad [FM137]**

Allow friends access to your property using an identification code that you provide. Program up to 25 entry codes for added security. Powered by three "AA" batteries (not included).



### **Mounting Post [FM100] - In Ground**

Designed to mount digital keypads, wireless intercom systems, and other access control devices for your gate automation system.

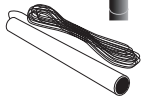

### **Mighty Mule® Vehicle Sensor [FM138]**

Automatically activates gate operator "Hands-Free" when a vehicle exits the property. Electromagnetic sensor detects vehicles in motion.



### **Automatic Gate Lock Pull-to-Open [FM143]**

The #1 Accessory For Swing Gate Operators! Designed for added security in conjunction with **Mighty Mule** Automatic Gate Operators. The gate lock unlocks and locks automatically when the gate opens and closes. The perfect solution for high wind conditions.

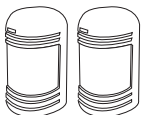

### **Photo Beams [R4222]**

Primary "through beam" photo beam device. Provides "non-contact" obstruction protection.



## Accessories are Available From Your Retail Store (con't)

---



### Wireless Entry Intercom / Keypad [FM136]

Allows owner to screen guest at the gate before allowing access to the property. Keypad also allows owner to give up to 25 programmable entry codes to family, friends or approved delivery personnel. Codes can be permanent or temporary. Can be wireless up to 500 feet. Additional base stations available (F3101MBC).

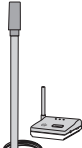

### Driveway Alarm [FM231]

This device alerts you of vehicles entering your driveway (with or without an automated gate). The indoor base station signals you with a door chime when a vehicle passes the driveway sensor.

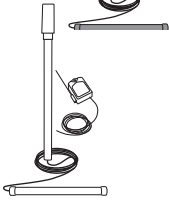

### Wireless Driveway Vehicle Sensor [FM130]

Automatically activates gate operator "Hands-Free" when a vehicle exits the property. 100 ft. range between transmitter and receiver. Easy installation.



### Low Voltage Wire [RB509]

The 16 gauge, stranded, dual conductor low voltage Wire is for connecting the AC powered transformer, solar panel or wired accessories to the system's control board. This specially designed wire is UV resistant, PVC coated, and ready for direct burial.

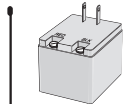

### Replacement Transformer [RB570]

Standard 18 volt, 2200 mA AC transformer included with the FM360 to maintain battery charge.



### Garage Door Receiver [RB709U-NB]

The Garage Door Receiver allows you to use the same **Mighty Mule** entry transmitter to operate your gate operator and your garage door operator. Compatible with most garage door operators.



### Push to Open Bracket [FM148]

Required when the FM360 must push a gate open (arm extends to open), such as away from a sloping driveway or where space prevents gate from opening into the property (pull to open).

**If you have a question about any special order item,  
just call 1-800-543-GATE!**

The contents of all material available on this installation manual are copyrighted by GTO Access Systems, LLC. ("GTO"), unless otherwise indicated. All rights are reserved by GTO, and content may not be reproduced, downloaded, disseminated, published, or transferred in any form or by any means, except with the prior, written permission of GTO. Any reprinting of GTO publications is by permission only. Copyright infringement is a violation of federal law.

Mighty Mule®, E-Z Gate®, GTO®, and "Dual Sense Technology" are registered trademarks of GTO, America's DIY Automatic Gate Openers is a trademark of GTO and are the exclusive property of GTO. All rights are reserved by GTO, and these marks may not be used, in any for without the prior, written permission of GTO.

## **Gate Operator Installation Checklist**

---

- 1. The gate has been checked to make sure it is level and moves freely in both directions.
- 2. Potential pinch areas have been guarded so as to be inaccessible OR have sensing edges and/or photo beam obstruction detection devices installed.
- 3. The installer has installed one or more contact or non-contact obstruction sensing devices, if required for this installation.
- 4. If pedestrian traffic is expected, a separate pedestrian gate has been installed, a minimum of seven feet from the gate system. All pedestrian traffic must use the pedestrian gate.
- 5. Warning signs have been installed on each side of the gate in highly visible locations. These signs must remain at all times.
- 6. There are no controls installed on the gate operator, or within ten feet of the gate.
- 7. The Dual Sense Technology feature has been properly adjusted and tested to make sure that the gate stops and reverses a short distance with minimal resistance applied.
- 8. Reviewed and understand all of the operational functions, obstruction sensing devices, warning beeper and reset, etc.
- 9. Review and understand the proper use of the operator's manual disconnect feature. The manual disconnect must never be used while the gate is in motion. The power switch must be turned off before using the manual disconnect and disengaging the operator.
- 10. Reviewed all safety instructions, and keep the safety instructions and owner's information sheets for reference.
- 11. Review and understand the maintenance schedule for both the gate and the gate operator.



3121 Hartsfield Road • Tallahassee, Florida, USA 32303  
Telephone Mighty Mule Sales: 1-800-543-4283 • Fax (850) 575-8912  
or Mighty Mule Technical Service: 1-800-543-1236 • Fax (850)575-8950  
[www.mightymule.com](http://www.mightymule.com)

