

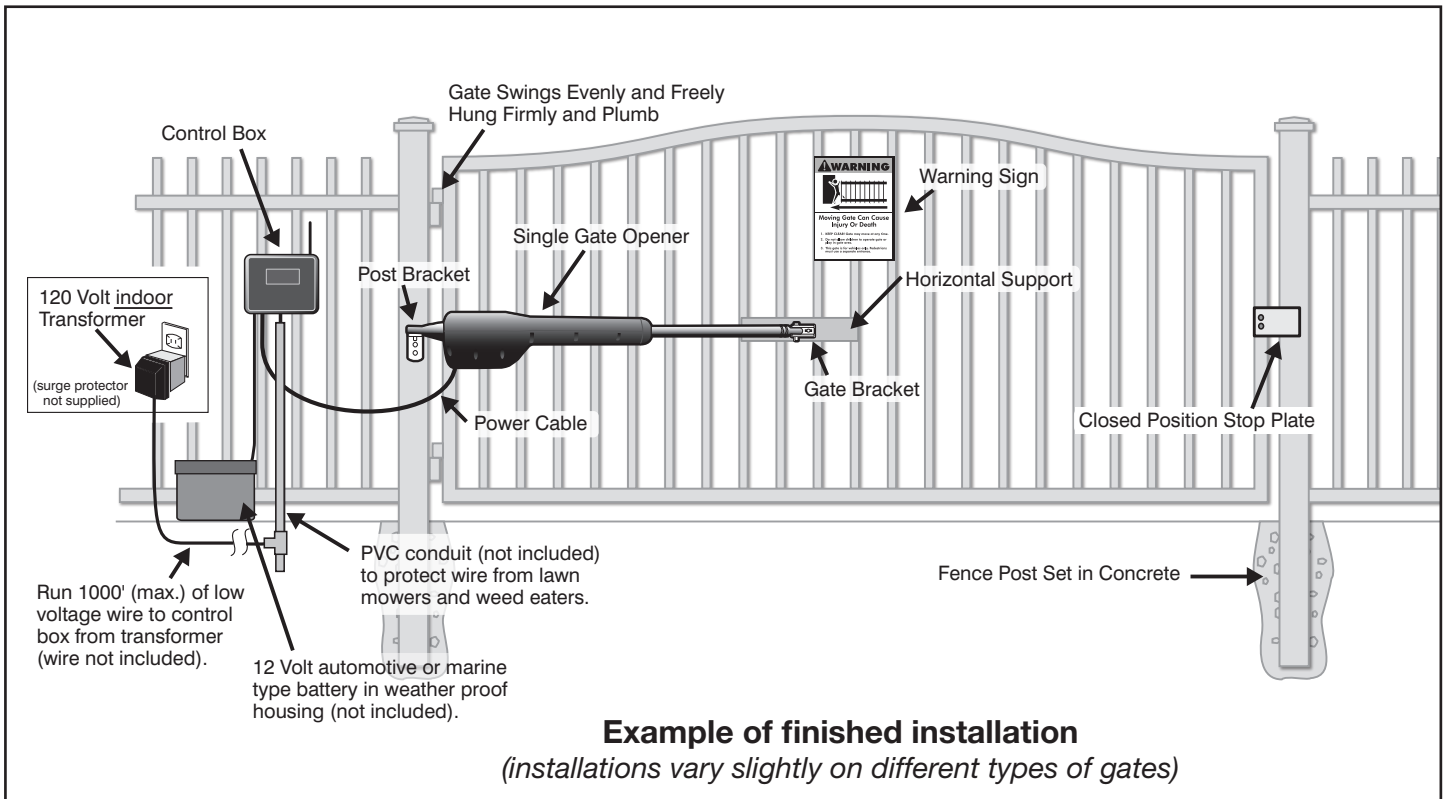

MM260

Installation Manual



This product meets the requirements of UL325 6th Edition, 2016, the standard for gate operator safety.

Mighty Mule® is the retail brand of GTO Access Systems, LLC
3121 Hartsfield Road • Tallahassee, FL 32303





WARNING

This equipment meets Underwriters Laboratory Standard 325 (UL 325). However, gate equipment has hazards associated with its use and therefore by installing this product the installer and user accept full responsibility for following and noting the installation and safety instructions. Failure to follow installation and safety instructions can result in hazards developing due to improper assembly. You agree to properly install this product and that if you fail to do so GTO Access Systems, LLC, shall in no event be liable for direct, indirect, incidental, special or consequential damages or loss of profits whether based in contract tort or any other legal theory during the course of the warranty or at any time thereafter. The installer and/or user agree to assume responsibility for all liability and use of this product releasing GTO Access Systems, LLC, from any and all liability. If you are not in agreement with this disclaimer or do not feel capable of properly following all installation and safety instructions you may return this product for full replacement value.

READ ALL INSTRUCTIONS CAREFULLY AND COMPLETELY before attempting to install and use this automatic gate operator. This gate operator produces a high level of force. Stay clear of the unit while it is operating and exercise caution at all times.

ALL AUTOMATIC GATE OPERATORS ARE INTENDED FOR USE ON VEHICULAR GATES ONLY.

Product Usage

The Mighty Mule Gate Operator meets all of the safety requirements of a **Class I** Residential Vehicular Gate Operator and is intended for use solely with vehicular swing gates in single-family residential applications that meet the Class I category listed in the table below.

Vehicular Gate Operator Class Categories

Residential Vehicular Gate Operator-Class I:

A vehicular gate operator (or system) intended for use in garages or parking areas associated with a residence of one-to-four single families.

Commercial/General Access Vehicular Gate Operator-Class II:

A vehicular gate operator (or system) intended for use in a commercial location or building such as a multi-family housing unit (five or more single family units), hotel, garages, retail store, or other buildings accessible by or servicing the general public.

Industrial/Limited Access Vehicular Gate

Operator-Class III: A vehicular gate operator (or system) intended for use in an industrial location or building such as a factory or loading dock area or other locations not accessible by or intended to service the general public.

Restricted Access Vehicular Gate Operator-

Class IV: A vehicular gate operator (or system) intended for use in an industrial location or building such as a factory or loading dock area or other locations not accessible by or intended to service the general public.

Table of Contents

PLEASE READ THIS FIRST	ii
IMPORTANT SAFETY INFORMATION	iii
TECHNICAL SPECIFICATIONS	x
BEFORE YOU BEGIN	xi
Powering Options	xi
Check Existing Gate Size and Material	xii
Check for Proper Gate Installation.....	xii
Gate Grounding	xii
Items Included.....	xiii
Tools Needed	xiv
Items Not Included	xiv
GATE OPENER INSTALLATION.....	1
CLOSED POSITION STOP PLATE INSTALLATION.....	3
CONTROL BOX AND BATTERY INSTALLATION	4
TRANSFORMER WIRING INSTALLATION	5
SOLAR PANEL INSTALLATION	6
SETTING PERSONAL TRANSMITTER CODE	7
SETTING CLOSED LIMIT POSITION	8
SETTING DUAL SENSE DETECTION AND AUTO CLOSE TIME	9
CONNECTING ADDITIONAL DEVICES	10
CONTROL BOARD CONNECTIONS	11
CONNECTING ACCESSORIES	12
MAINTENANCE	13
TROUBLESHOOTING GUIDE	13
REPAIR SERVICE	15
CONVERSION CHART	16
ACCESSORIES	17

Please Read This First!

Thank you for purchasing a Mighty Mule Gate Operator—GTO's "do-it-yourself" automatic gate operator! When correctly installed and properly used, your Mighty Mule Gate Operator will give you many years of reliable service. Please read the following information and watch the enclosed video to ensure you have the correct system for your particular needs. Furthermore, this manual and the DVD will enable you to properly install your Mighty Mule Gate Operator.

The Mighty Mule Gate Operator is designed for installation on a pull-to-open single leaf gate (gates that open into the property). The gate must not exceed 12 feet in length or weigh more than 300 pounds (please see Technical Specifications on page x). The Mighty Mule Gate Operator can be used on vinyl, aluminum, chain link, farm tube, and wrought iron gates. Use on solid surface gates is not recommended. Solid surface gates have a high resistance to the wind. If the wind is strong enough, the operator will obstruct and stop.

The Mighty Mule Gate Operator accommodates extra transmitters, digital keypads, solar panels, push buttons, automatic gate locks, and other access control products. These optional accessories (see the Mighty Mule Accessory Catalog) are available at most stores. Your store should be able to special order any accessory not in stock. If your store cannot special order accessories, please call the Mighty Mule Sales Department (800-543-4283).

The Mighty Mule Gate Operator features Dual Sense Technology™. This feature makes the gate stop and reverse direction when it comes in contact with an obstruction. This is factory set to the most sensitive setting and must be adjusted during installation.

The Mighty Mule Gate Operator also has an adjustable auto-close feature. After the gate reaches the fully open position, it can be set to remain open up to 120 seconds before automatically closing. Pressing the transmitter button at any time after the gate opens fully will cause it to close immediately. OFF is the factory setting; meaning the gate will stay open until you press the transmitter (or keypad, etc.) again.

NOTE—If your application requires any of the following:

- Swing gates longer than 12 feet or weighing more than 300 pounds
- Slide gates
- Heavy duty or commercial uses
- Professional installation

Go to www.gtoaccess.com for a dealer or retailer near you or call (800) 543-4283 for information about our Linear PRO Access professional line of gate operators and accessories. Our Sales Department will be glad to give you the name and phone number of a Linear PRO Access dealer near you.

BEFORE YOU BEGIN TO INSTALL YOUR AUTOMATIC GATE OPERATOR:
watch the enclosed video and read these instructions carefully and completely to become familiar with all parts and installation steps. The video is only designed as an overview of the installation procedure. You must read the installation manual for detailed instructions on gate operator safety and proper use of the gate operator.



Important Safety Information

Because automatic gate operators produce high levels of force, consumers need to know the potential hazards associated with improperly designed, installed, and maintained automated gate operator systems. **Keep in mind that the gate operator is just one component of the total gate operating system.** Each component must work in unison to provide the end user with convenience, security, and safety.

This manual contains various safety precautions and warnings for the installer end user. Because there are many possible applications of the gate operator, the safety precautions and warnings contained in

this manual cannot be completely exhaustive in nature. It does, however, provide an overview of the safe design, installation, and use of this product. **CAREFULLY READ AND FOLLOW ALL SAFETY PRECAUTIONS, WARNINGS, AND INSTALLATION INSTRUCTIONS TO ENSURE THE SAFE SYSTEM DESIGN, INSTALLATION, AND USE OF THIS PRODUCT.**



Warnings in this manual are identified with this warning symbol. The symbol identifies conditions that can result in damage to the operator or its components, serious injury, or death.

Because Mighty Mule automatic gate operators are only part of the total gate operating system, it is the responsibility of the installer and end user to ensure that the total system is safe for its intended use.

Manually Opening and Closing Gate

CAUTION

The gate will move freely and uncontrolled when the gate operator is removed from the gate. **ONLY** disconnect the operator when the control box power switch is **OFF** and the gate is **NOT** moving.

Disconnecting the Operator

1. Turn control box power switch OFF.
2. Remove hairpin clip, clevis pin, and bushing from either the front or rear mounting point.
3. Remove the operator from the mount.

The gate can be opened and closed manually when the operator is disconnected.

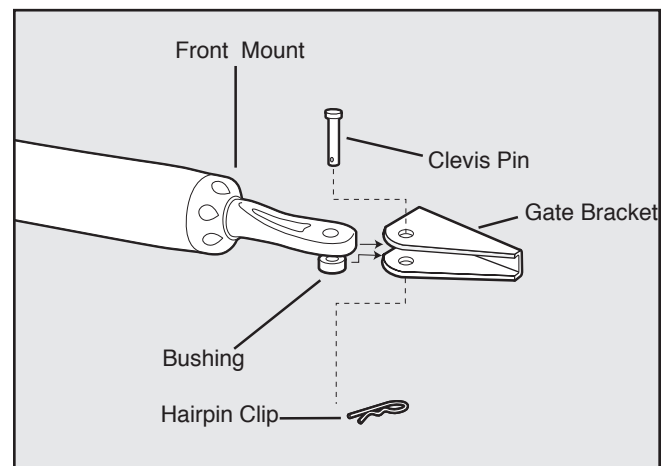

NOTE: Substitute a **Pin Lock** for the clevis pin on the front mount of the gate operator to prevent theft of the operator from the gate (see accessory pages in back of this book).

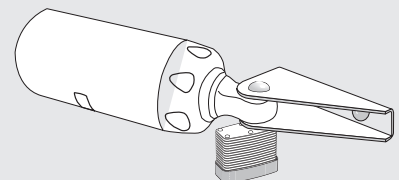

Important Safety Information

For the Installer and End User

WARNING

To reduce the risk of injury or death:

1. **READ AND FOLLOW ALL INSTRUCTIONS.**
2. Never let children operate or play with gate controls. Keep the remote control away from children.
3. Always keep people and objects away from the gate. **NO ONE SHOULD CROSS THE PATH OF THE MOVING GATE.**
4. Test the gate operator monthly. The gate **MUST** reverse on contact with a rigid object or stop when an object activates the non-contact sensors. After adjusting the force or the limit of travel, retest the gate operator. Failure to adjust and retest the gate operator properly can increase the risk of injury or death.
5. Use the manual/emergency release only when the gate is not moving.
6. **KEEP GATES PROPERLY MAINTAINED.** Read the user's manual. Have a qualified service person make repairs to gate hardware.
7. The entrance is for vehicles only. Pedestrians must use separate entrance.
8. The gate must be installed in a location that provides adequate clearance between it and adjacent structures when opening and closing to reduce the risk of entrapment. Swinging gates must not open into public access areas.
9. **SAVE THESE INSTRUCTIONS.**

I. Before Installation

1. Verify this operator is proper for the type and size of gate, frequency of use and class of the gate system.
2. Make sure the gate has been properly installed and swings freely in both directions. Repair or replace all worn or damaged gate hardware prior to installation. A freely moving gate will require less force to operate and will enhance the performance of the entrapment protection devices used with the system (see page xii).
3. Review the operation of the system to become familiar with its safety features. Understand how to disconnect the operator for manual gate operation (see page iii).
4. The gate and operator installation must comply with any applicable local codes.
5. This gate operator is intended for vehicular gates only. A separate entrance or gate must be installed for pedestrian use (see page viii).
6. Always keep people and objects away from the gate and its area of travel. No one should cross the path of a moving gate.
7. Identify all of the entrapment zones for the type of installation. An entrapment zone is an area around the automatic gate system where a person or object could be caught that increase the risk of injury. Entrapment zones must be eliminated, guarded or protected.
8. When designing a system that will be entered from a highway or main thoroughfare, make sure the gate system is placed far enough from the road to prevent traffic congestion.

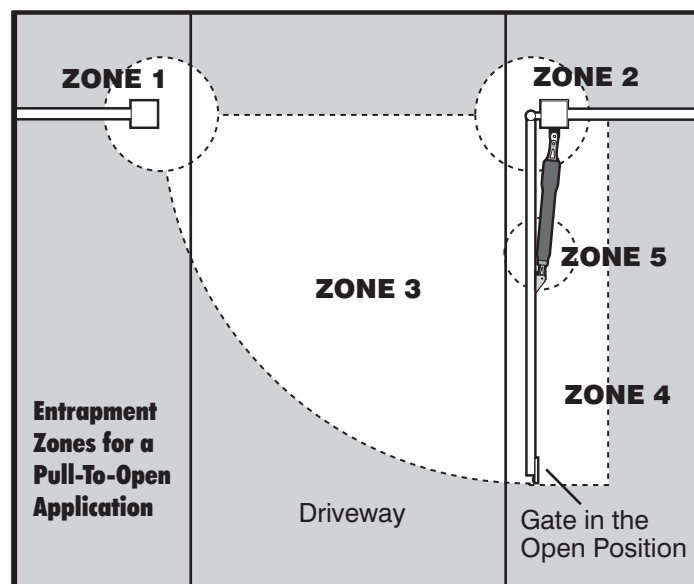

Important Safety Information

For the Installer and End User

Typical Entrapment Zones are shown in the diagrams on page iv:

Zone 1 – leading edge of the gate and the fence post.

Zone 2 – between the gate and the gate post.

Zone 3 – the path of the gate.

Zone 4 – the space between the gate in the open position and any object such as a wall, fence, tree, etc.

Zone 5 – pinch points between the operator and gate.

II. During Installation

1. Install the gate operator on the inside of the property and fence line. **DO NOT** install an operator on the outside of the gate where the public has access to it.
2. Be careful with moving parts and avoid close proximity to areas where fingers or hands could be pinched.
3. Devices such as contact sensors (sensing edges) and non contact sensors (photo beams) provide additional protection against vehicular damage.
4. If push buttons or key switches are installed, they should be within sight of the gate, located at least 10 feet from any moving part of the gate (see diagram below). **Never install any control device where a user will be tempted to reach through the gate to activate the gate operator.**
5. Do not activate your gate operator unless you can see it and can determine that its area of travel is clear of people, pets, or other obstructions. Watch the gate through its entire movement.
6. Secure outdoor or easily accessed gate operator controls in order to prohibit unauthorized use of the gate.

**NEVER install
any control device
within gray area**

Pull-To-Open Application

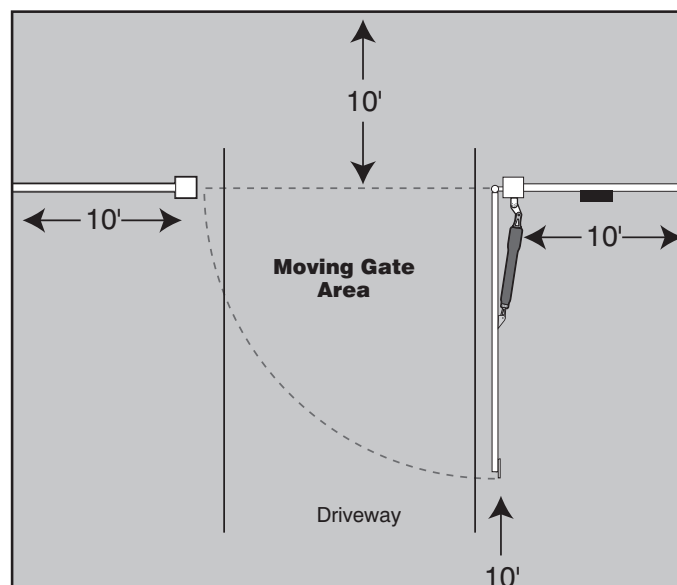

Important Safety Information

For the Installer and End User

III. After Installation

1. Attach the **warning signs** (included) to each side of the gate to alert the public of automatic gate operation. It is your responsibility to post warning signs on both sides of your gate. If any of these signs or warning decals becomes damaged, illegible, or missing, replace them immediately. Contact GTO for free replacements.
2. The gate is automatic and could move at any time, posing serious risk of entrapment. No one should be in contact with the gate when it is moving or stationary.
3. Do not attempt to drive into the gate area while the gate is moving; wait until the gate comes to a complete stop.
4. Do not attempt to “beat the gate” while the gate is closing. This is extremely dangerous.
5. Do not allow children or pets near your gate. **Never let children operate or play with gate controls.** Keep the remote control away from children and unauthorized users; store controls where children and unauthorized users do not have access to them.
6. **KEEP GATE SYSTEMS MAINTAINED.** Always turn power to operator OFF before performing any maintenance. See page 28 for maintenance procedures.
7. To operate this equipment safely, YOU must know how to disconnect the operator for manual gate operation (see page iii). If you have read the instructions and still do not understand how to disconnect the operator, contact the Mighty Mule Service Department.
8. Disconnect the operator **ONLY** when the power is **TURNED OFF** and the gate is **NOT** moving.
9. Make arrangements with local fire and law enforcement for emergency access.
10. Distribute and discuss copies of the **IMPORTANT SAFETY INFORMATION** section of this manual with all persons authorized to use your gate.
11. **IMPORTANT: Save these safety instructions. Make sure everyone who is using or will be around the gate and gate operator are aware of the dangers associated with automated gate systems. In the event you sell the property with the gate operator or sell the gate operator, provide a copy of these safety instructions to the new owner.**

Should you need a replacement manual, a copy can be obtained by downloading one from the Mighty Mule web site (www.mightymule.com), by contacting GTO, at 3121 Hartsfield Road, Tallahassee, Florida 32303 or by calling 1-800-543-4283 and requesting a duplicate copy.

Important Safety Information

For the Installer and End User

Mighty Mule gate operators utilize Dual Sense Technology™ entrapment protection. Dual Sense Technology™ is built into every Mighty Mule and provides redundant methods of entrapment protection for open and close gate directions.

In addition to Dual Sense Technology, every Mighty Mule gate controller has provisions for the connection of additional obstruction detection devices such as sensing edges and photo beams.

These devices may be located where there is an increased risk of obstruction. Refer to the diagram below.

One or more edge sensors may be located at the leading edge, bottom edge, and post edge, both inside and outside of a vehicular swing gate system.

Wiring to sensors must be located and arranged so the wiring between the sensor and the gate operator is not subjected to mechanical damage.

A wireless sensor such as one that transmits radio frequency (RF) signals to the gate blocked for obstruction protection functions shall be located where the transmission of the signals is not obstructed or impeded by building structures, natural landscaping or similar objects.

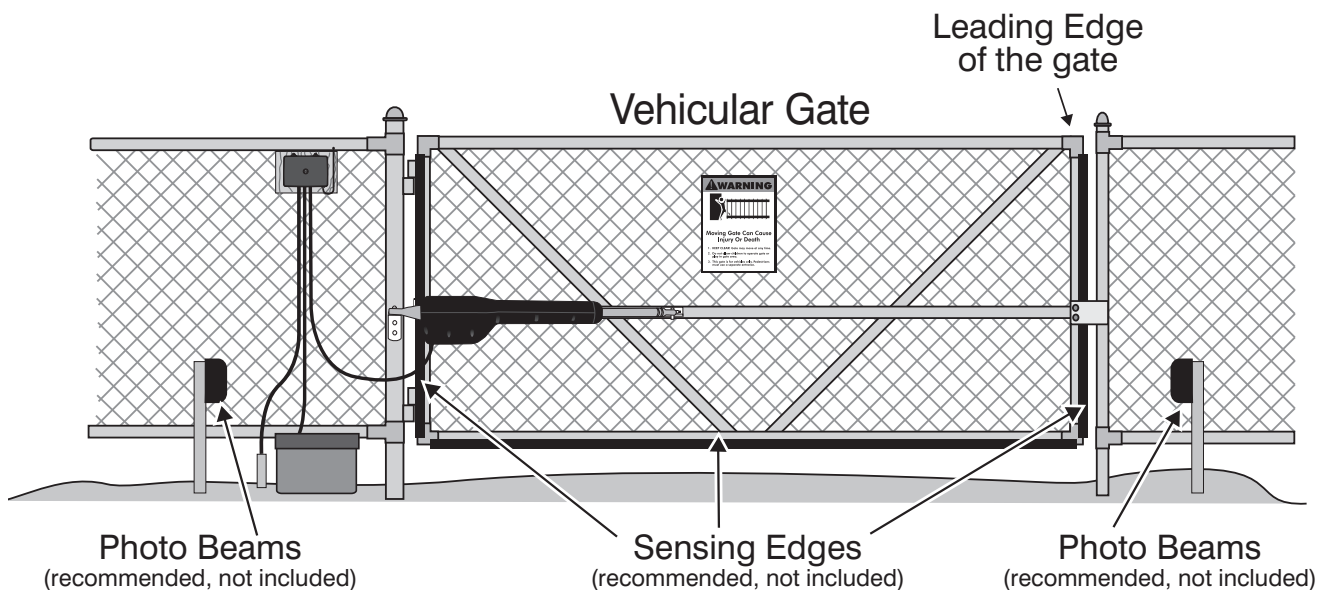

Entrapment and Obstruction Protection

Mighty Mules's Dual Sense Technology™ provides entrapment protection, even when properly adjusted. Since all installations are different, you may need to add photo beams or sensing edges to help prevent damage to vehicle or other items that could be hit by a moving gate.

Entrapment Alarm

The Mighty Mule Automatic Gate Operator is designed to stop and reverse the gate when the gate comes in contact with an obstruction. Additionally, these operators are equipped with an audio entrapment alarm which will activate if the unit obstructs twice while opening or closing. This alarm will sound for a period of 5 minutes, or until the operator receives an intended signal from a hard wired entry/exit source (e.g. push button control or keypad) and the gate returns to a fully open or fully closed position. Turning the power switch on the control box OFF and back ON will also deactivate the alarm. Wireless controls such as transmitters and wireless keypads will not deactivate the alarm.

Important Safety Information

Installing Warning Signs and Pedestrian Gates

Warning signs alert people of automatic gate operation and are required when installing Mighty Mule Automatic Gate Operators. A minimum of two WARNING SIGNS must be installed in the area of the gate. Each sign is to be visible by persons located on the side of the gate on which the placard is installed.

The operator is intended for installation only on gates used for vehicles. Pedestrians must be supplied with a separate access opening. The pedestrian access opening shall be designed to promote pedestrian usage. Locate the gate such that persons will not come in contact with the vehicular gate during the entire path of travel of the vehicular gate.

We recommend using the GTO Bulldog Pedestrian Gate Lock (Call the GTO Sales Department at 800-543-4283) for controlled access.

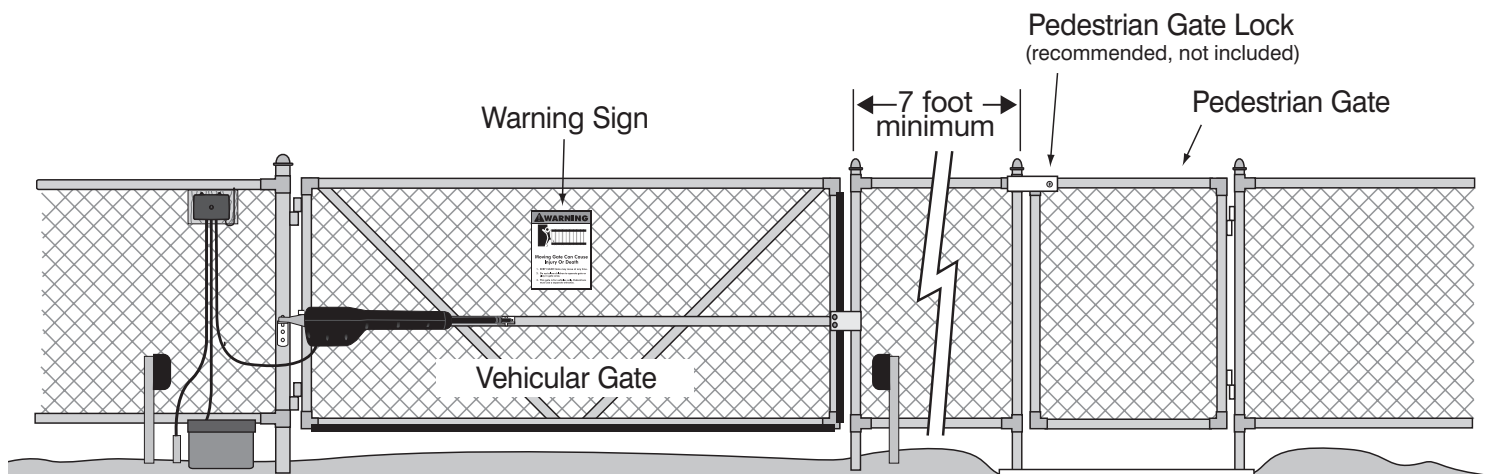

Warning Signs

The gate operator is provided with 2 safety warning signs. The signs **MUST** be installed on the front and back of the gate where they will be visible in the area of the gate.

Permanently secure each warning sign to the gate.

Immediately replace a damaged or missing warning sign.



Important Safety Information

Required Safety Precautions for Gates

These warning labels should be found at the locations specified below. If any of them are missing, immediately contact GTO for replacements.



Logo and warning labels (2) installed on each side of opener housing



Control box label (1) installed on front of control box

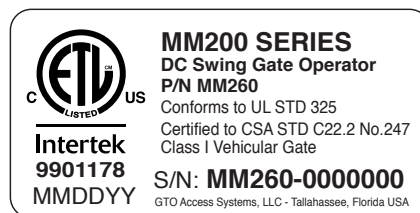

Product identification label (1) installed under rear mount on arm.

Technical Specifications

Mighty Mule 260 Gate Opener

DRIVE

- Low friction screw drive (linear actuator) rated for -5 °F to +160 °F (-20 °C to +71 °C).
- Powered by a 12 V motor with integral gear reducer. Motor speed reduced to 260 rpm.
- Maximum opening arc of 110°. Approximate opening time (90°): 18 seconds, depending on weight of gate.

POWER

- The system is powered by a 12 Vdc automotive or marine battery.
- Battery charge is maintained by Mighty Mule transformer or optional Mighty Mule Solar Panels.
IMPORTANT: Never use both transformer and solar panel - this will damage the battery and control board.
- One (1) blade-style fuse is rated for 15 A.

NOTE: The transformer should not be directly connected to any battery. Do not replace fuses with higher ampere rated fuses; doing so will void your warranty and may damage your control board.

CONTROL

- GTO microprocessor-based control board for single leaf, pull-to-open gate installations.
- A circuit on the control board regulates charging. "Sleep draw" is 15 mA; "active draw" is 2 to 5 A.
- Auto-memorization of digital transmitter code.
- GTO RF receiver tuned to 318 MHz.
- Opener length with push-pull tube fully retracted is 26³/₈", mounting point to mounting point. Maximum stroke is 13".
- Adjustable auto-close timer (OFF, 3 to 120 seconds), and Dual Sense Technology Stall Force.
- Power terminal block accommodates a transformer or solar panels.
- Accessory terminal block fully compatible with all Mighty Mule access controls.
- Control board allows connection of edge sensors and photoelectric sensors.
- Audio entrapment alarm sounds if unit encounters an obstruction twice while opening or closing.

OPERATIONAL CAPACITY

- The Gate Capacity Chart shows approximate cycles, per day, you can expect from the Mighty Mule Automatic Gate Opener when powered with a transformer and 12 volt battery, prior to the battery depleting to a state where the unit will not function. Actual cycles may vary slightly depending upon the type and condition of gate and installation.

Mighty Mule 260 Gate Capacity /Cycle Chart

Estimated number of daily cycles, based on use with a transformer.

		Number of Cycles Per Day			
Gate Weight	300 lbs.	77	72	67	62
	150 lbs.	82	77	72	67
	100 lbs.	87	82	77	72
	50 lbs.	92	87	82	77
		5' - 6'	8'	10'	12'
		Gate Length			

NOTE: BALL BEARING HINGES SHOULD BE USED ON ALL GATES WEIGHING OVER 250 LB.

To determine the number of cycles the gate opener will perform using solar panels, please see the specifications. These specifications are subject to change without notice.

* An operation cycle is one full opening and closing of the gate.

Before You Begin

POWERING OPTIONS

1. Determine Charging Option for Battery: Transformer OR Solar

NEVER USE TRANSFORMER AND SOLAR PANEL(S) AT THE SAME TIME. It will damage the control board.

IMPORTANT:

- The Mighty Mule gate opener is designed and intended for use with a 12 Volt automotive or marine type battery. The battery must be placed inside a weatherproof case and located within 6 feet of the opener arm. The 8 foot harness supplied connects the battery to the opener arm.
- The transformer is designed for indoor use. If the transformer can be plugged only into an outside electrical outlet, a weatherproof cover/housing (available at local electrical supply stores) must be used.
- If your gate is more than 1000 ft. from an AC power source, you will need to use at least 5 watts solar charging power to charge the battery [FM121]. Refer to the Solar Panel and Gate Activity chart below.
- All low voltage wire used with the Mighty Mule gate opener must be 16 gauge dual conductor, stranded, direct burial wire [RB509]. Do not run more than 1000 ft. of wire.

SOLAR PANEL AND GATE ACTIVITY CHART

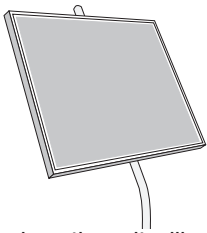

The table and map illustrate the maximum number of gate cycles to expect per day in a particular area when using from 5 to 30 watts of solar charging power prior to the battery depleting to a state

where the unit will not function. The figures shown are for winter (minimum sunlight). Accessories connected to your system will draw additional power from the battery.

Deep cycle marine battery is recommended for solar and/or high traffic applications.

Single Gate Winter Ratings	Zone 1	Zone 2	Zone 3
12 v single gate (5 watts) solar charger	4	8	13
12 v single gate (10 watts) solar charger	8	16	26
12 v single gate (15 watts) solar charger	11	20	30
12 v single gate (20 watts) solar charger	14	28	38
12 v single gate (25 watts) solar charger	17	36	46
12 v single gate (30 watts) solar charger	20	44	54

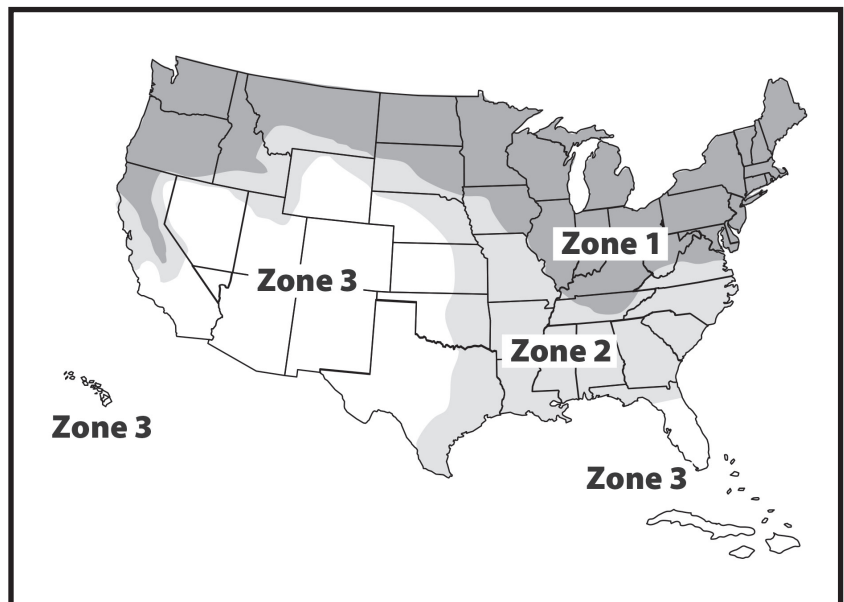

Before You Begin

Check Existing Gate Size and Material

- Gate size: Up to 12 feet or up to 300 lbs—See chart on page x.
- Type of gate material: Vinyl, aluminum, chain link, farm tube, wrought iron, wood (not recommended for solid surface gates).

IMPORTANT: Check for Proper Gate Installation

- The gate must be plumb, level, and swing freely on its hinges.
- The gate must move throughout its arc without binding or dragging on the ground.
- Wheels must NOT be attached to the gate.
- Gates over 250 lb. should have ball bearing hinges with grease fittings.
- Post must be secured in the ground with concrete (minimizes twist/flex when the operator is activated).
- Make sure there is a stable area for mounting the gate bracket (this may require the addition of a horizontal or vertical cross member).
- We recommend you position the operator near the center-line of the gate to keep the gate from twisting and flexing, and to avoid back-splash from rain.

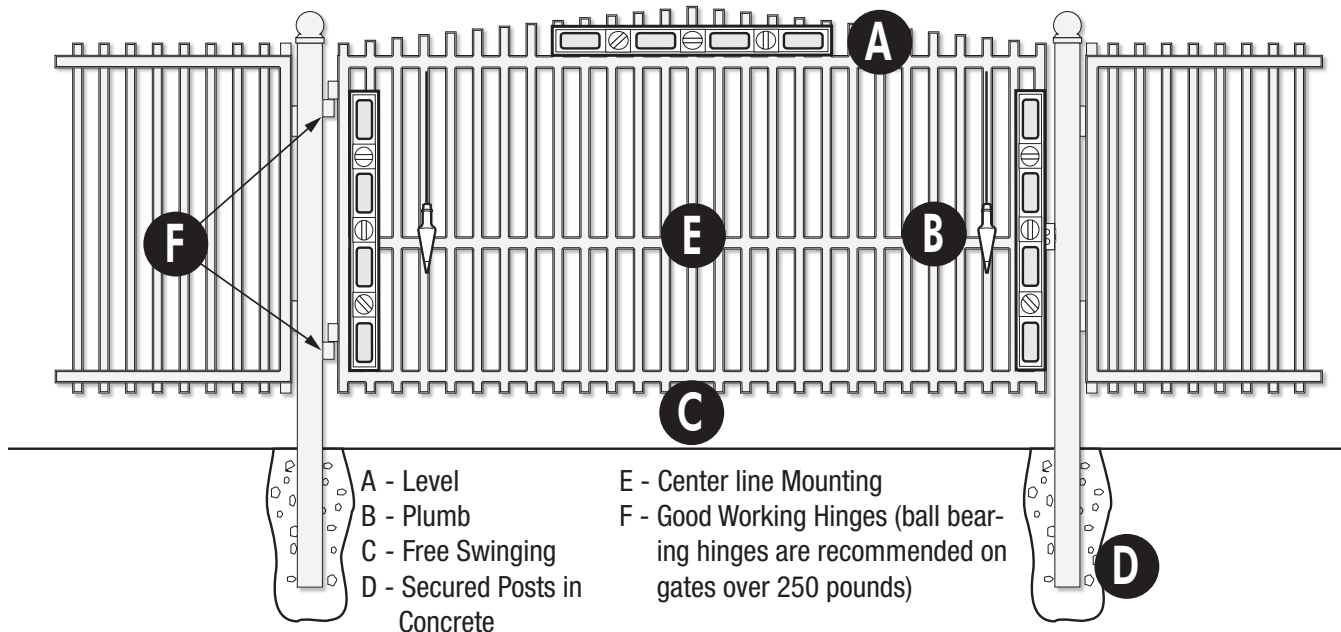

Gate Grounding

- Shorter wire (6 AWG) is better, 1 to 2 feet recommended.
- Bolt ring terminal at end of cable 4 - 6 inches above ground level.

R4196 Kit Includes:

- Ground Rod Clamp
- 6 AWG Wire (3 feet)

NOTE: No grounding system absolutely protects against lightning strikes. If installed correctly, a grounding system will help minimize damage to your gate opener.

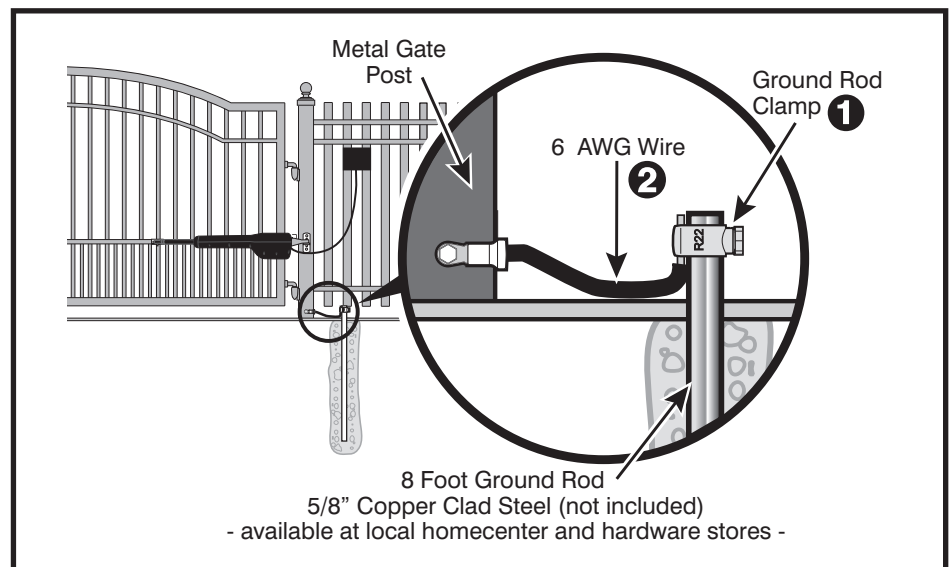

Items Included

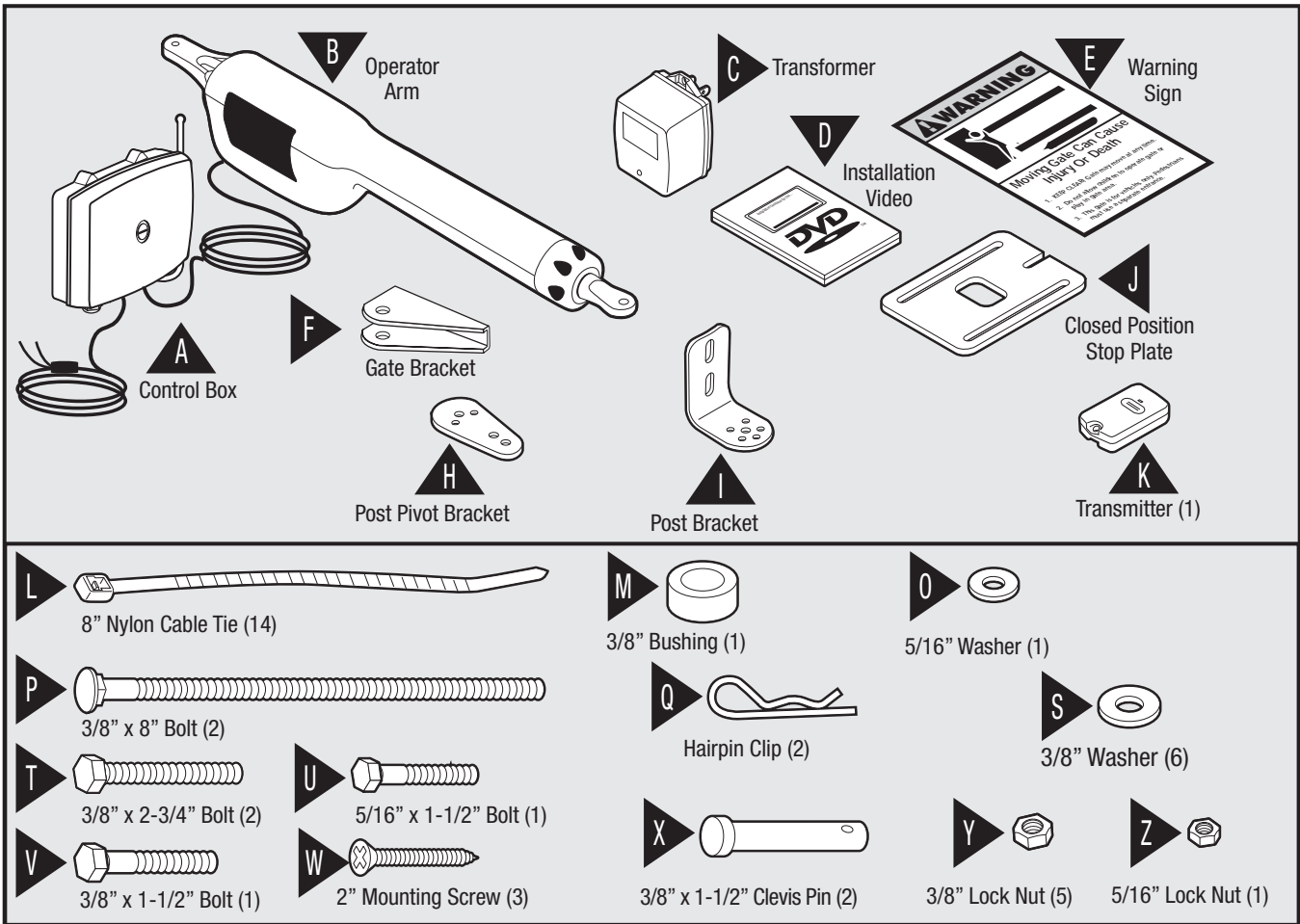

Before You Begin

Tools Needed

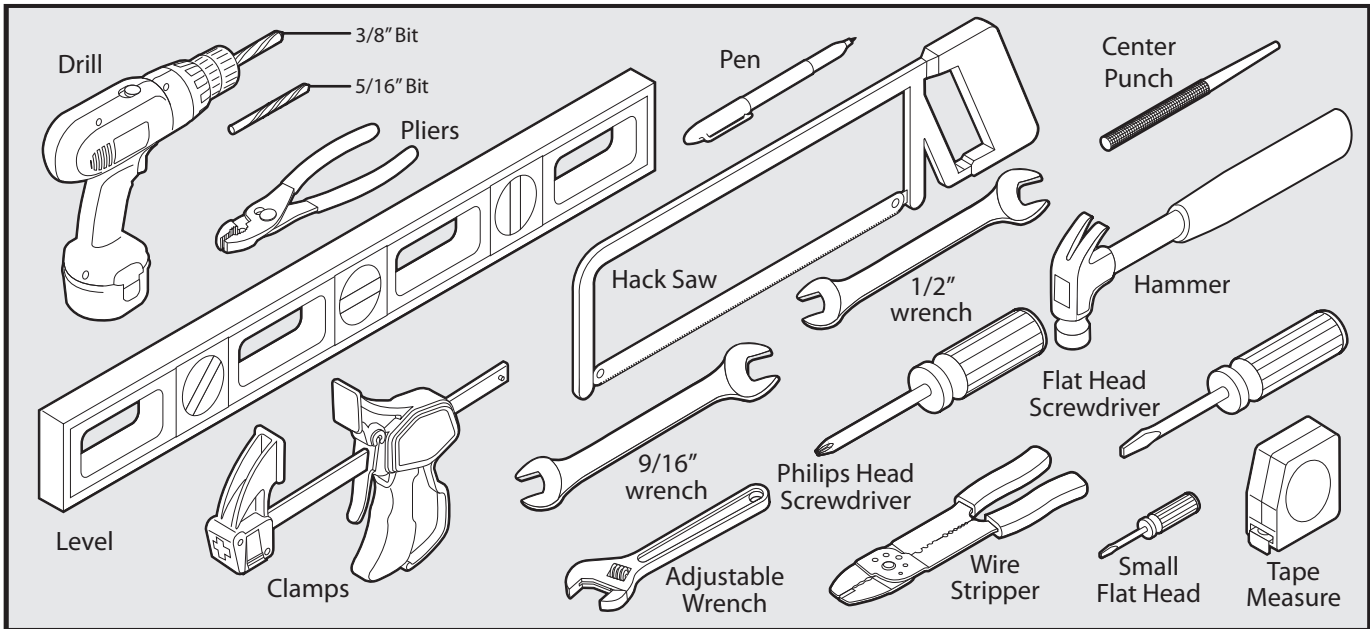

Items Not Included

- 12 Volt automotive or marine battery and a weather proof case.
- Low voltage wire will be needed to run from the transformer to the control box; length depends upon the distance between the transformer power supply and the control box. See Transformer Wiring Installation on page 5, and the accessory catalog.
- PVC conduit.
- If your gate is more than 1000' away from an ac power source you will need to use at least one Mighty Mule 5 watt solar panel to trickle charge the battery. See the accessory catalog (Do not use both transformer and solar).
- If you have thin walled tube or panel gates, see Recommended Reinforcement Examples after Step 3 of "Mounting Operator to Gate".
- Depending on the type of gate, a horizontal cross member or mounting plate may be needed to mount the front of the opener and gate bracket to the gate. See Gate Bracket Mounting Examples after Step 3 of "Gate Operator Installation."
- Surge protection for transformer.
- Some types of installations require u-bolts.
- Additional washers or a metal plate may be needed for wooden post.
- Weatherproof cover for outdoor outlet and transformer.
- Strain relief bushings for wiring accessory devices to control box.
- If post is more than 6", bolts longer than 8" are needed.

GATE OPENER INSTALLATION

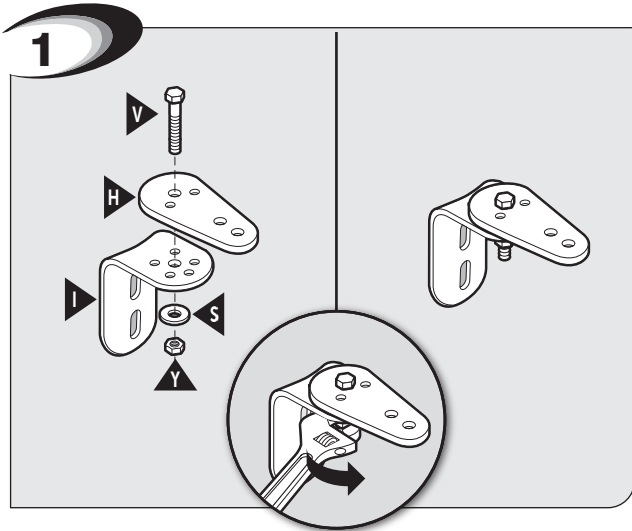

Assemble post bracket parts.

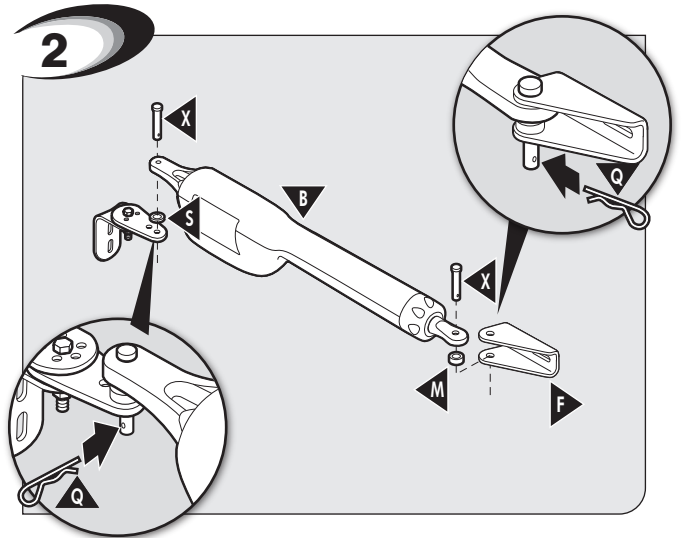

Attach opener to gate and post bracket and secure with required hardware.

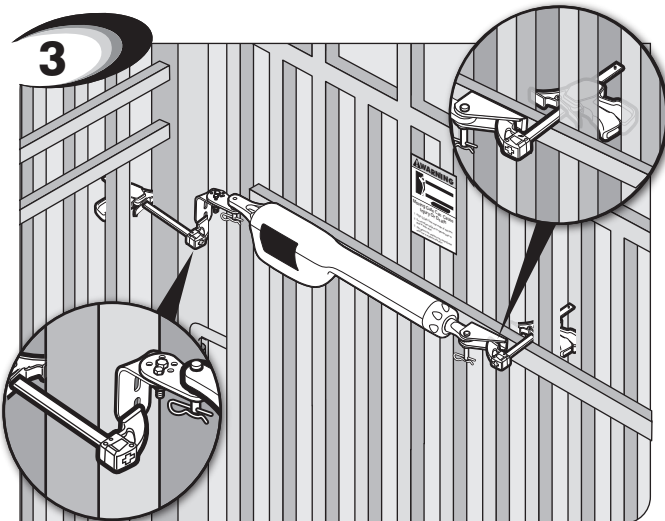

With Gate in OPEN position, using clamps, secure opener to gate post and center cross member of gate.

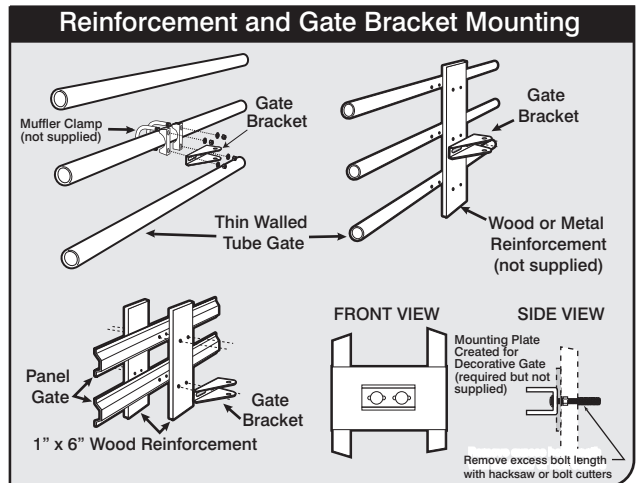

Recommended reinforcement and gate bracket mounting examples.

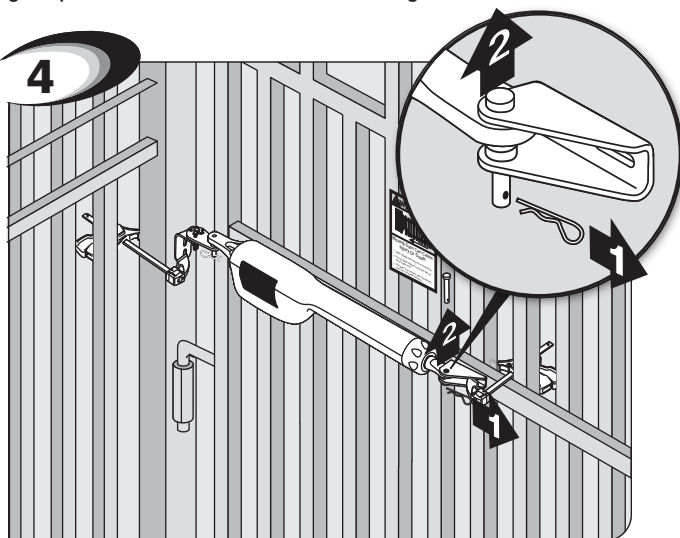

Remove clevis pin from the gate bracket and support loose opener.

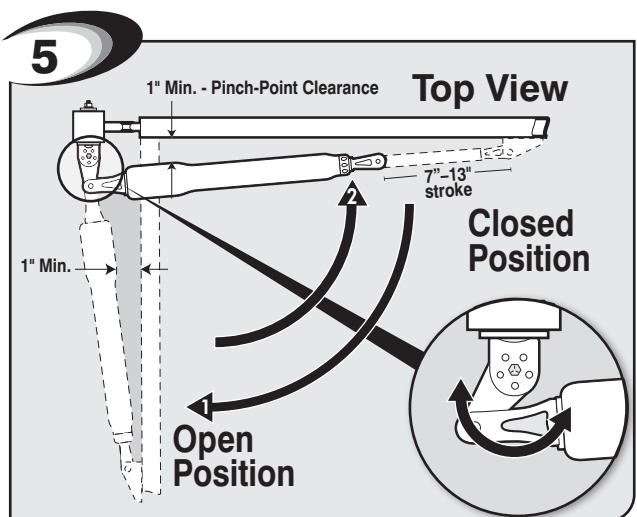

Swing gate and opener arm to the CLOSED position-check clearance/binding by inspecting alignment. Arm stroke should be a minimum of 7" and maximum of 13". TIP: Turning the pivot bracket over gives more hole alignment options for the post pivot bracket assembly.

GATE OPERATOR INSTALLATION

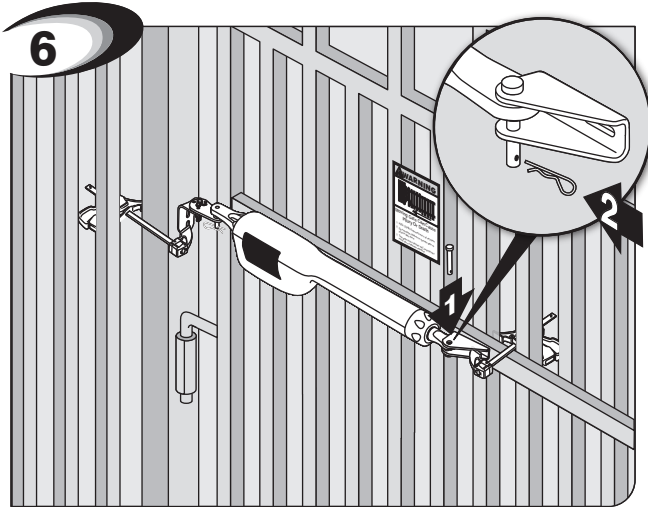

6 OPEN gate and reattach opener with clevis pin. Check for level. Clamp securely.

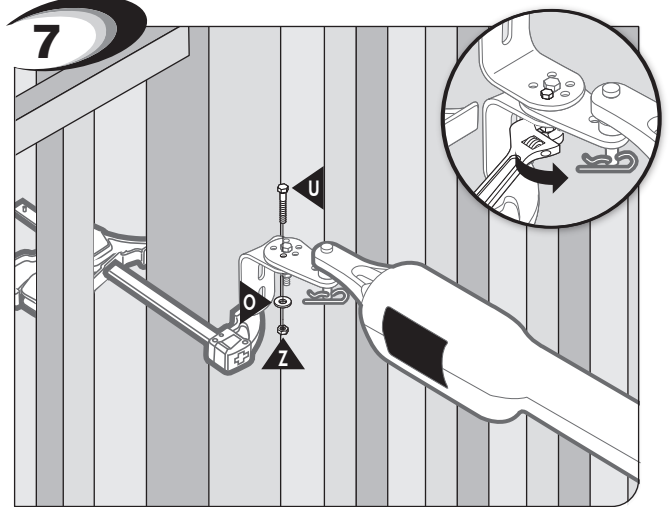

7 Secure post pivot bracket to post bracket with the hardware provided (O,U,Z) when you have achieved the 1" clearance shown in Step 5 in both open and closed positions.

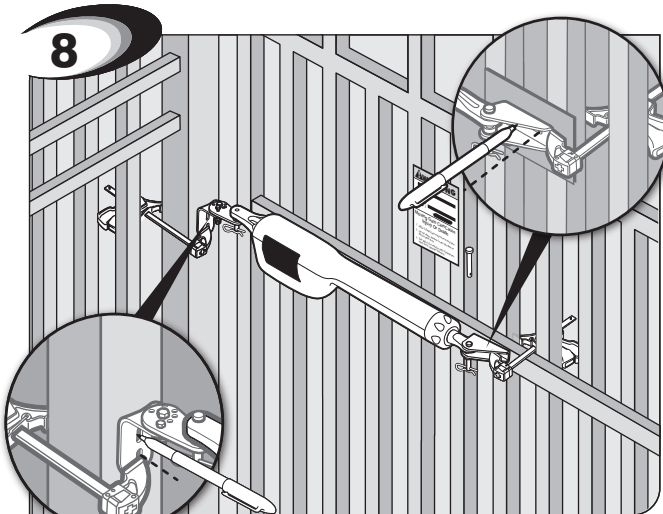

8 Mark middle of post bracket slots on fence post. Mark middle of gate bracket slots on gate cross support.

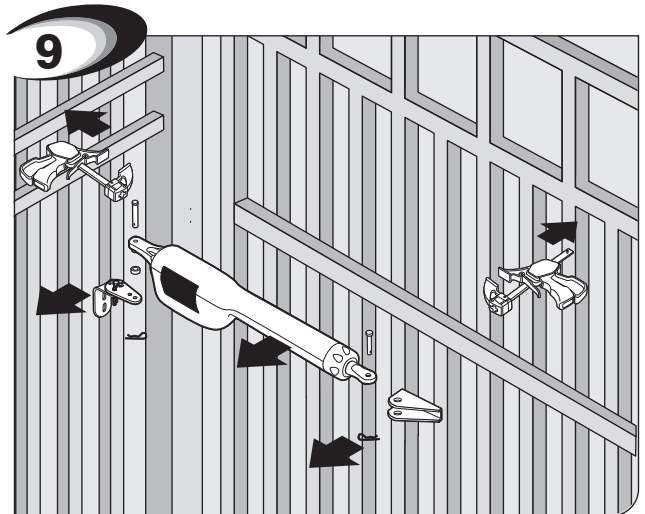

9 Remove clamps, post bracket, gate bracket, and opener. Then use a hammer and center punch to mark hole positions.

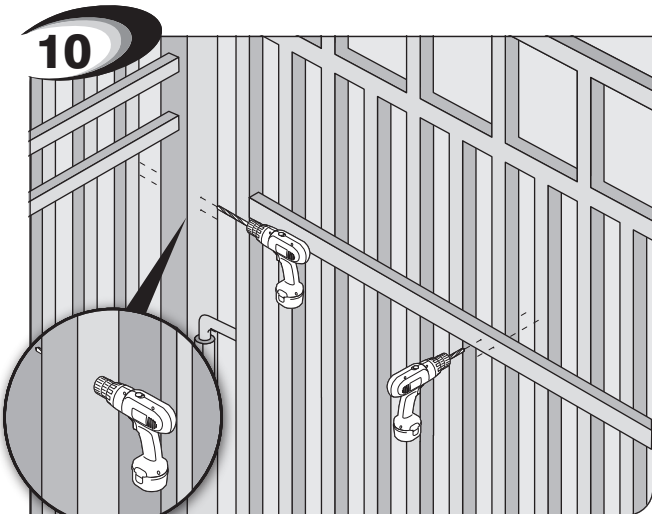

10 Drill holes completely through gate post and gate cross support.

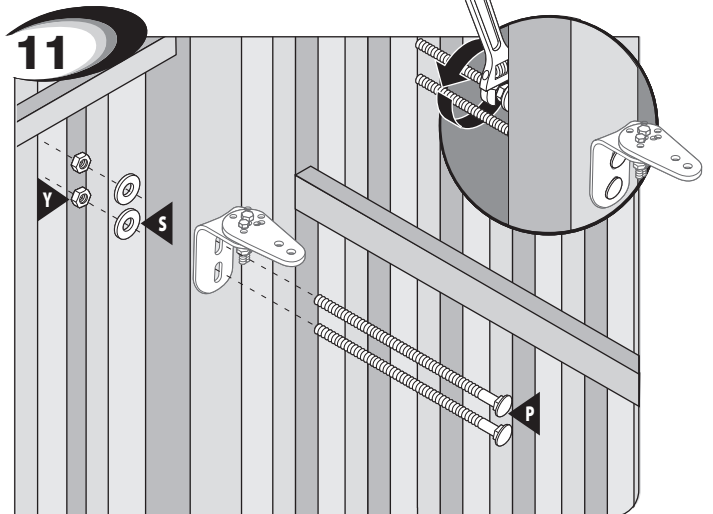

11 Attach post bracket assembly to fence post. NOTE: Must be through bolted.

GATE OPERATOR INSTALLATION

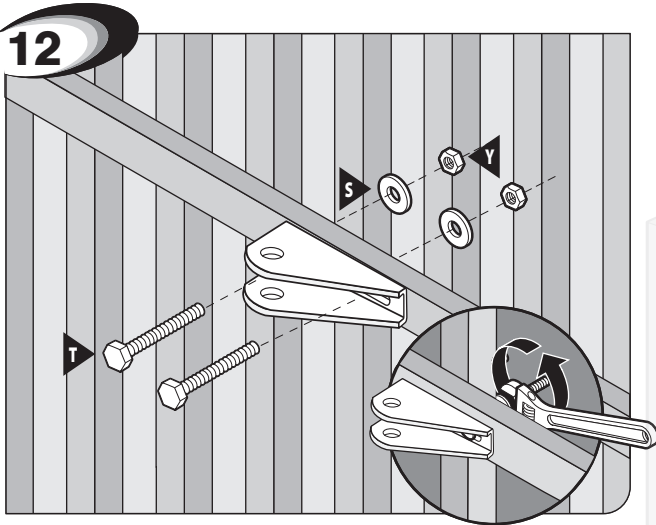

Attach gate bracket assembly to gate cross support.

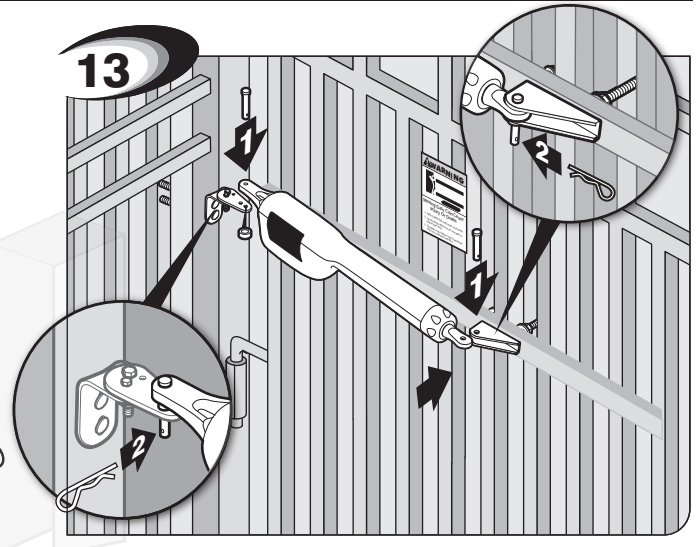

Attach and secure opener assembly to brackets.

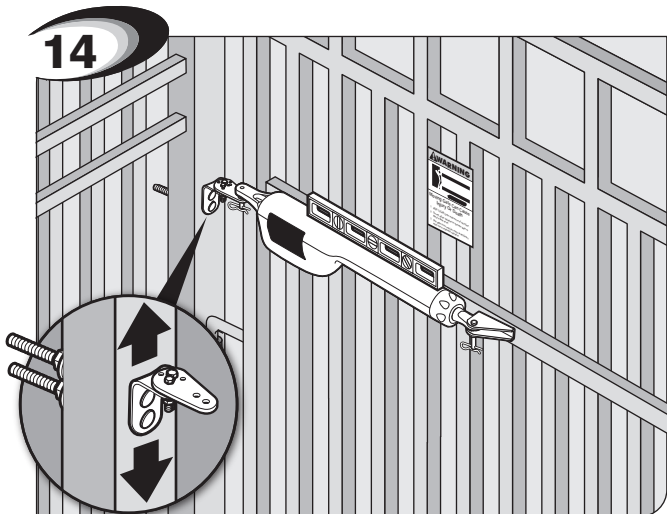

Check for level. Adjust post bracket if necessary.

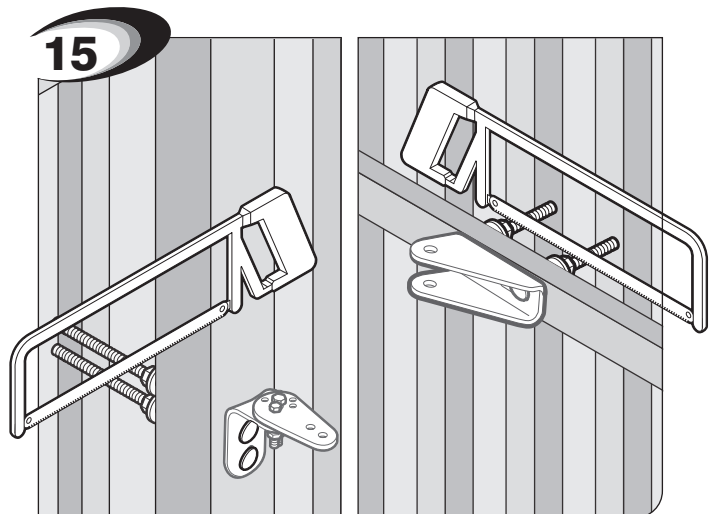

Tighten all bolts and remove excess length on post and gate bracket bolts with hacksaw.

CLOSED POSITION STOP PLATE INSTALLATION

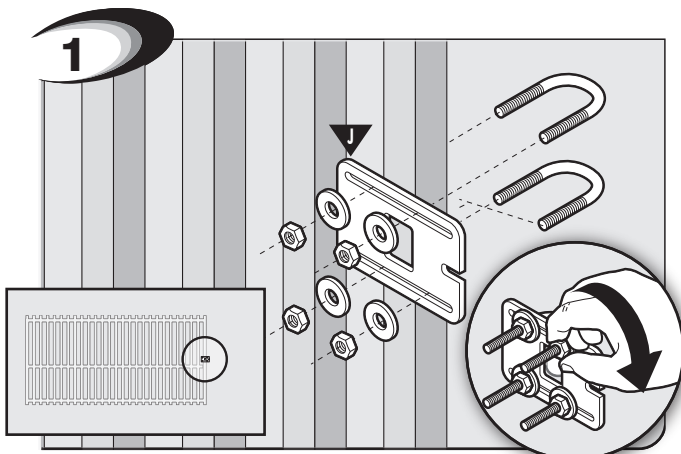

Remove the arm from the front bracket then attach gate stop to the leading edge of the gate with one of the following:

- U-bolts—tube and chain link gates (Not included)
- Wood/lag screws—flat aluminum/wood supports (Not included).

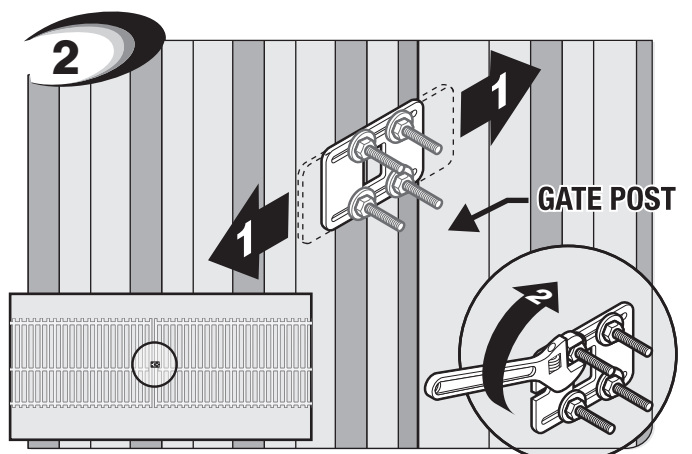

Position gate stop with gate CLOSED to fence post. Tighten fasteners. Cut off excess bolt length.

CONTROL BOX & BATTERY INSTALLATION

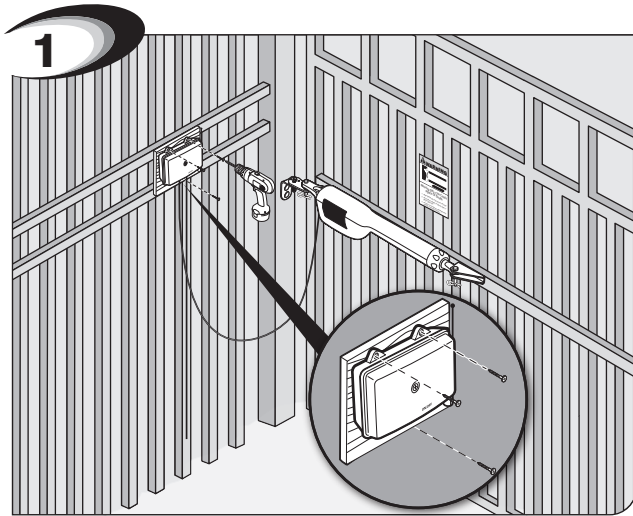

1 Mount control box on piece of treated plywood then attach it to post or fence using screws.

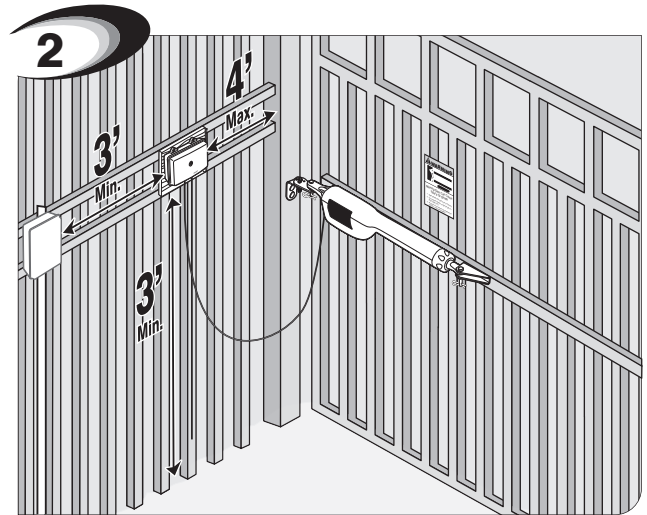

2 Locate control box mounting area. **IMPORTANT:** Be sure to mount box at least 3 feet from AC power and 3 feet off the ground.

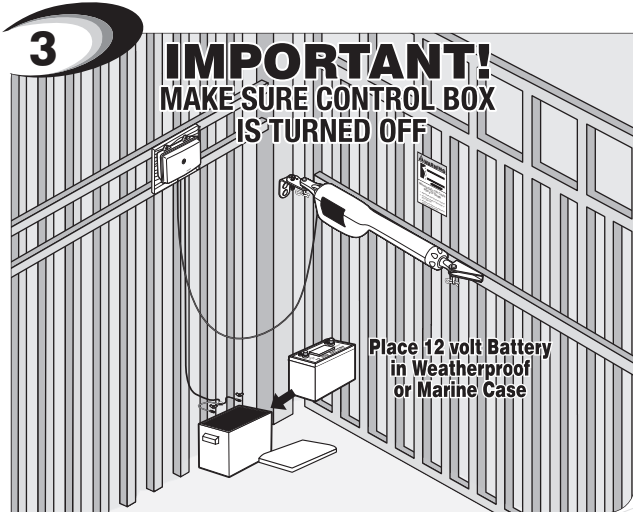

3 Make sure control box is turned OFF. Place 12 Volt battery and weatherproof battery box within 6 feet of the control box. Attach the battery harness wires from the control box to the battery terminals.

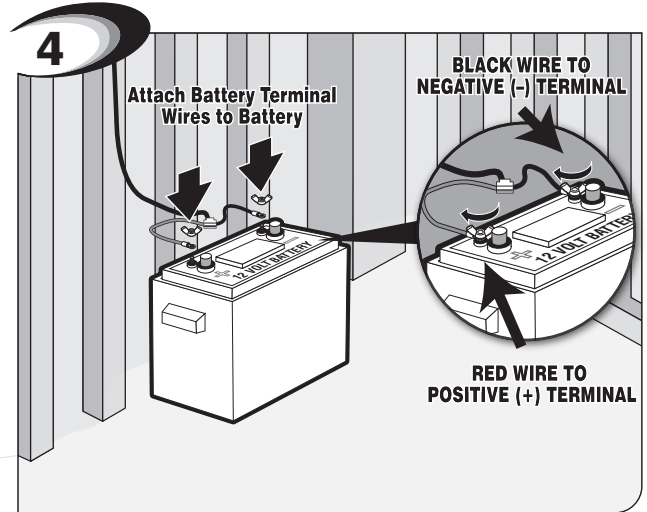

4 Tighten the bolts, washers, and nuts and place the cover on the weatherproof box. **IMPORTANT:** Do not connect the transformer or solar panel directly to the battery.

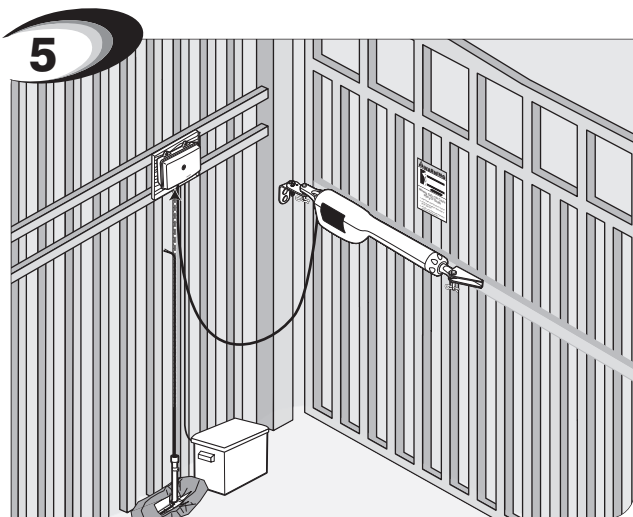

5 Use PVC conduit from ground up to control box.

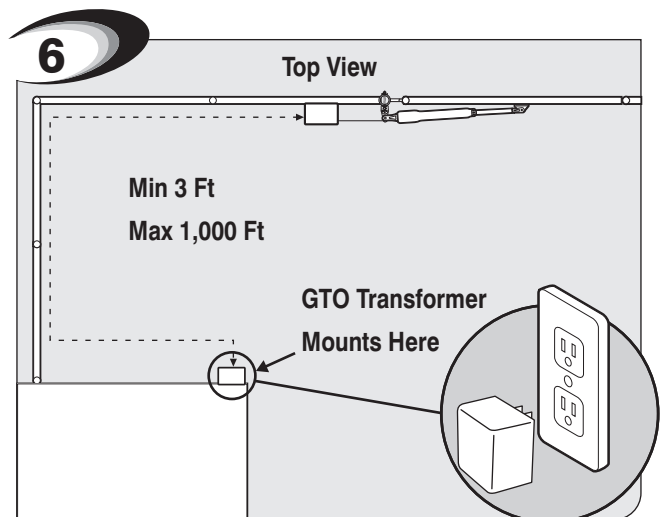

6 Locate power outlet and identify wire path to control box. **NOTE:** If OUTLET is OUTSIDE use weatherproof cover.

TRANSFORMER WIRING INSTALLATION

NOTE: If using a solar panel charging kit, go to page 6.

⚠ WARNING

Before digging contact local authorities to locate underground utilities such as electric and gas service.

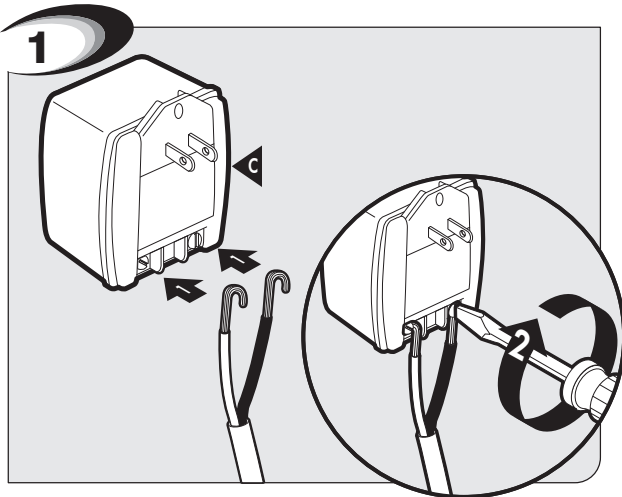

Strip 1/2" off 2 wires and twist ends. Attach wires to transformer screw terminals.

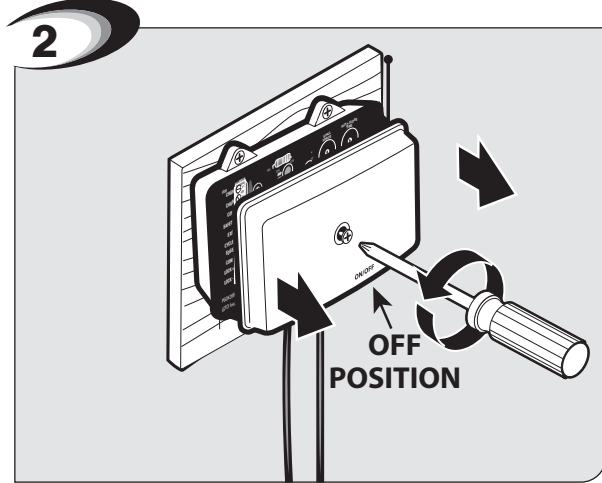

With the Control Panel OFF, remove control panel cover by unscrewing center cover fastener.

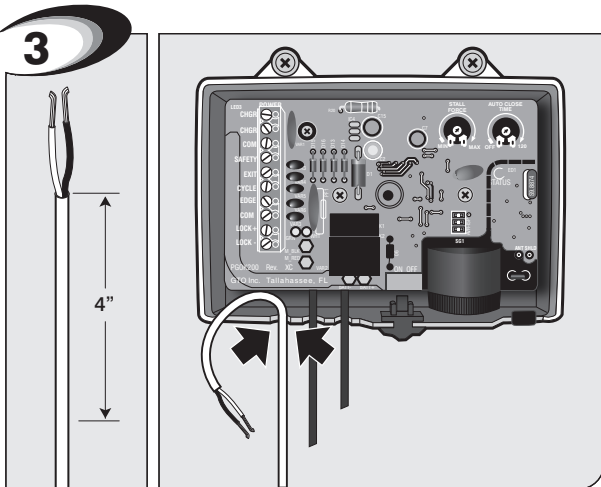

Feed 4" of low voltage wire through strain relief into box with battery wire harness.

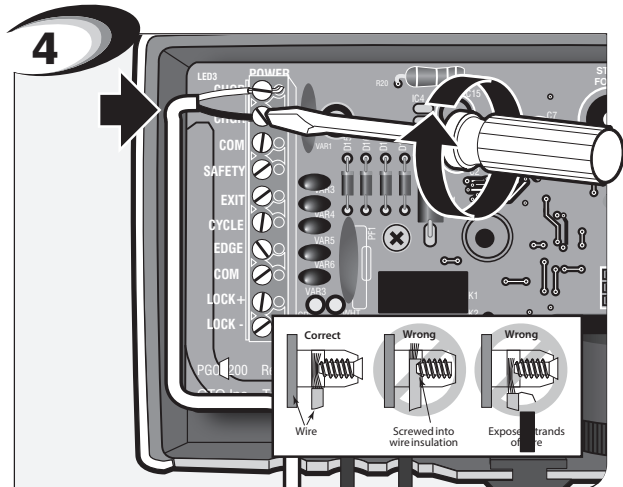

Insert RED and BLACK wires into CHGR terminals interchangeably as shown.

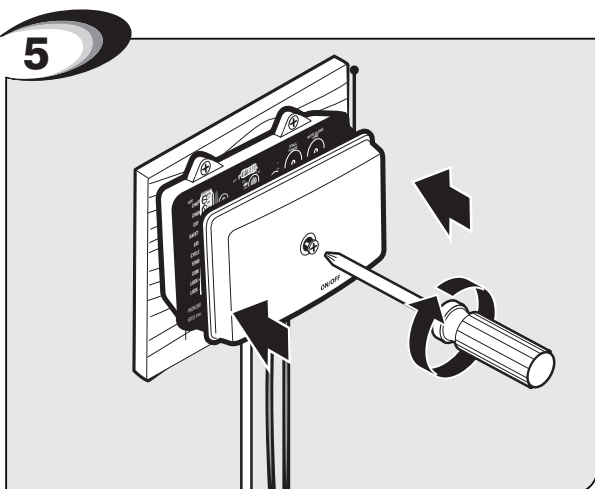

Attach cover back onto the control box.

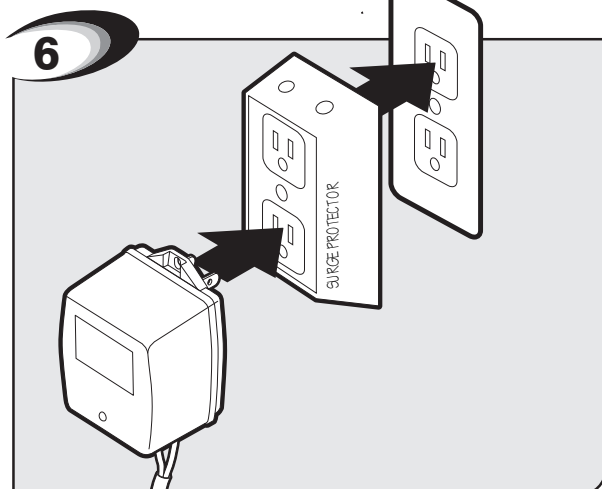

Plug in transformer to power outlet. (Use of a surge protector is highly recommended. If outdoors use weatherproof box.)

SOLAR PANEL INSTALLATION

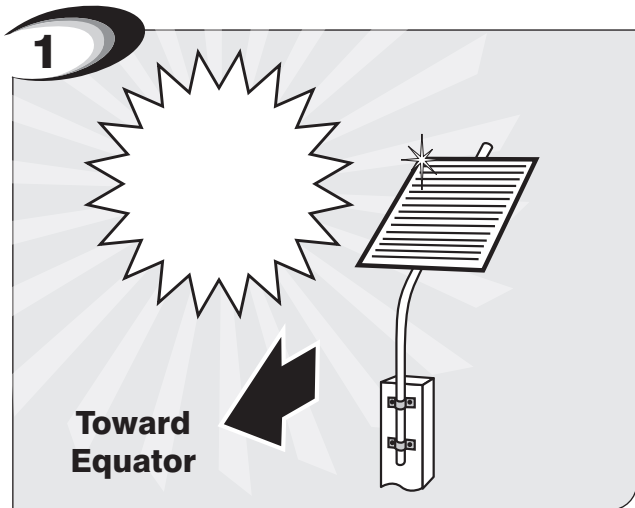

Position solar panel facing sun and in a non-shaded open area that allows 8 hours of direct sunlight for a full charge.

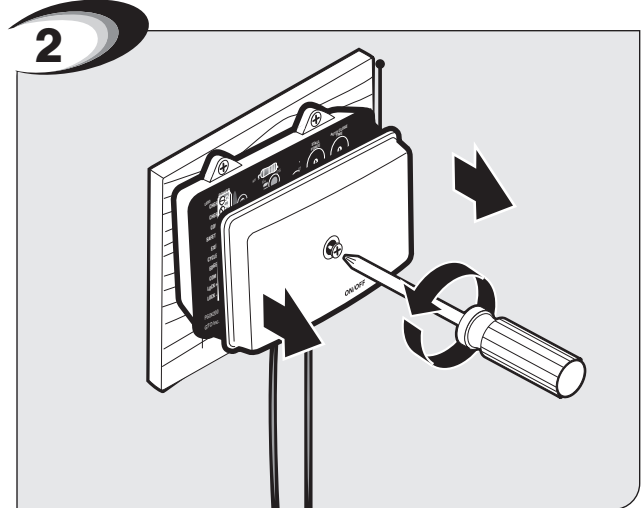

With the Control Panel OFF, remove control panel cover by unscrewing center cover fastener.

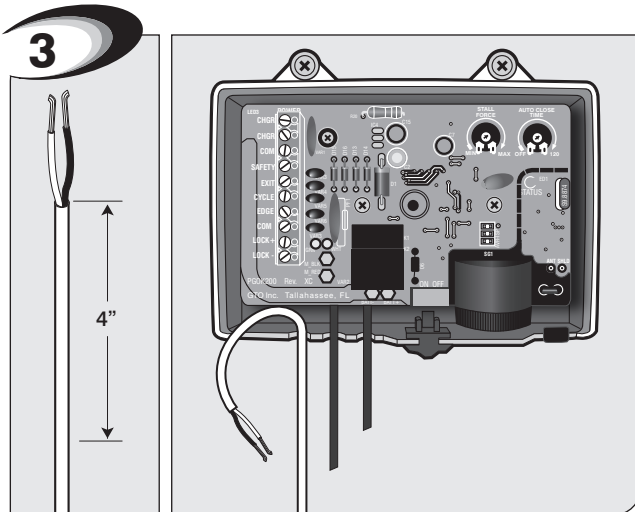

Feed 4" of the solar panel wire through strain relief into control box.

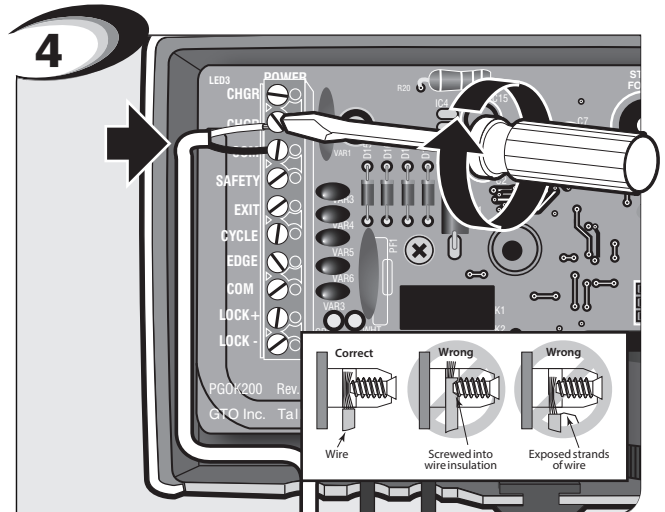

Insert red (+) wire into CHGR terminal and the black (-) wire into the COM terminal.

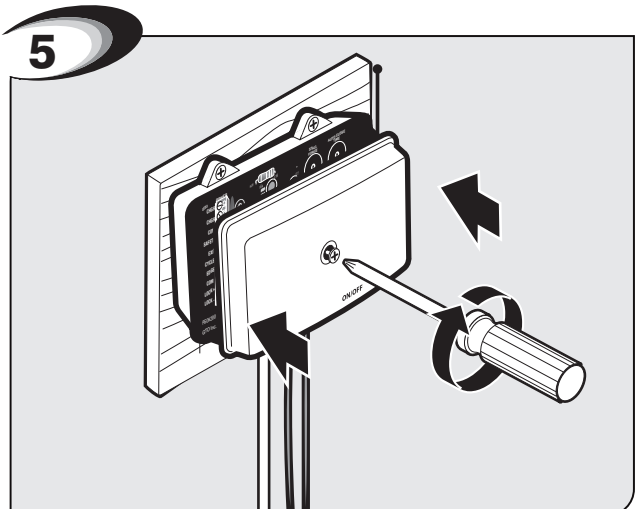

Reattach cover. Turn power on.

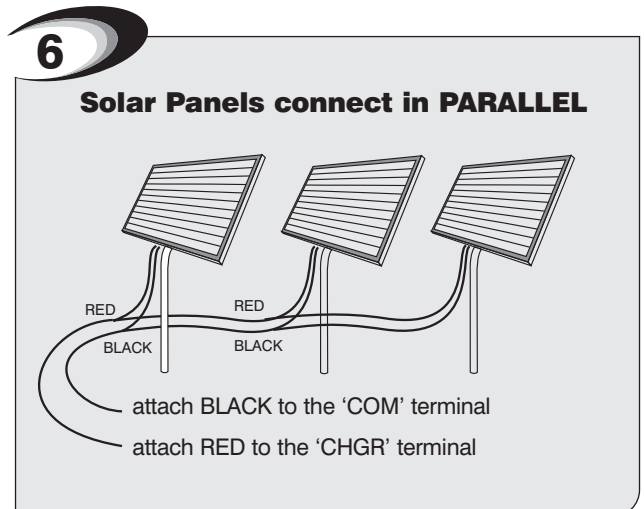

For multiple solar panels, wire the panels in parallel as shown.

SETTING PERSONAL TRANSMITTER CODE

All Mighty Mule transmitters are set to a standard code at the factory and are ready to operate your gate opener. For your safety and security, we strongly recommend that you replace the factory setting with your own personal code. Follow the directions below:

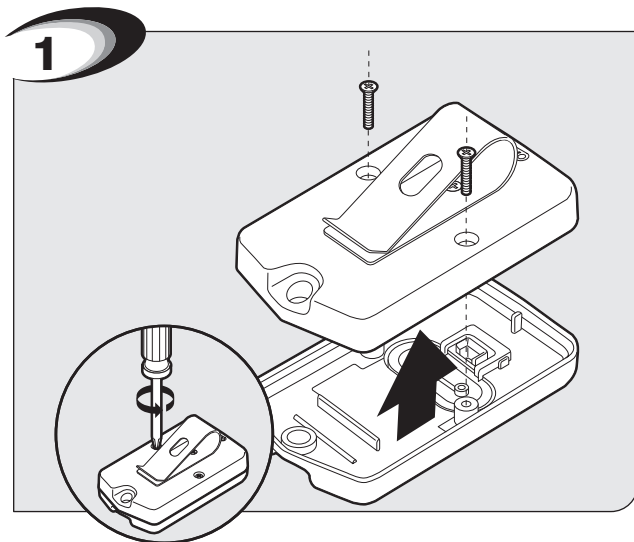

Remove back cover of the transmitter.

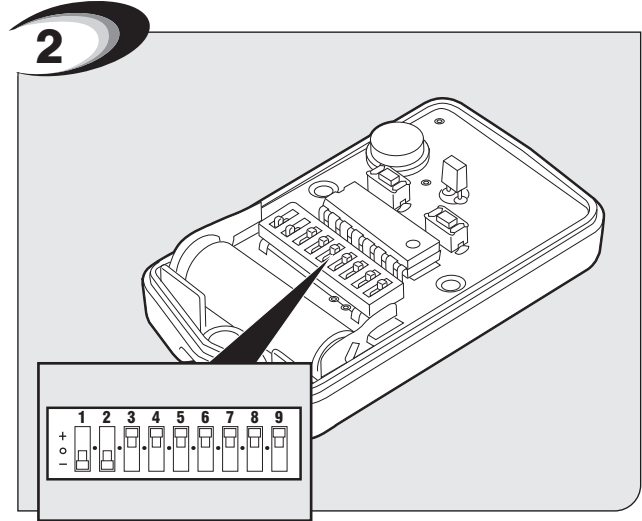

Flip transmitter over. Use small screwdriver to move switches to random positions. If you have more than one transmitter, now is a good time to set them all with the same code.

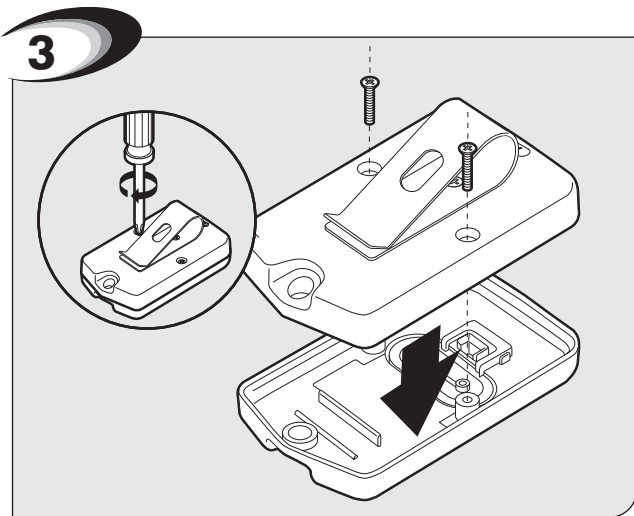

Replace back cover of the transmitter.

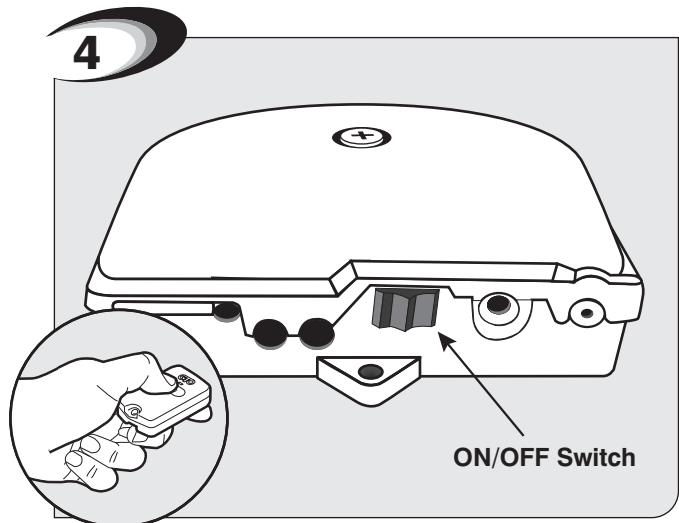

Make sure the control box is in the OFF position. Press and hold transmitter button while sliding the ON/OFF switch to the ON position. You will hear a series of beeps followed by a pause then a single beep. Release transmitter's button and the beeps will stop. Your personal code is now programmed. **This process may take 8-10 seconds.**

NOTE: All transmitters set to the same DIP switch code will now operate the gate opener.

WARNING: Changes, modifications or adjustments not expressly approved by GTO Access Systems, LLC could void the user's authority to operate this equipment. There Are No User Serviceable Parts.

NOTICE: This equipment has been tested and found to comply with the limits for a Class B digital device, pursuant to part 15 the FCC. These limits are designed to provide reasonable protection against harmful interference in a residential installation. This equipment generates, uses and can radiate radio frequency energy and, if not installed and used in accordance with the instructions, may cause harmful interference to radio communications. However, there is no guarantee that interference will not occur in a particular installation. If this equipment does cause harmful interference to radio or television reception, which can be determined by turning the equipment off and on, the user is encouraged to try to correct the interference by one or more of the following measures:

- Reorient or relocate the receiving antenna.
- Increase the separation between the equipment and receiver.
- Connect the equipment into an outlet on a circuit different from that to which the receiver is connected.
- Consult the dealer or an experienced radio/TV technician for help.

This device complies with Part 15 of the FCC Rules. Operation is subject to the following two conditions: (1) This device may not cause harmful interference, and (2) this device must accept any interference received, including interference that may cause undesired operation.

SETTING CLOSED LIMIT POSITION

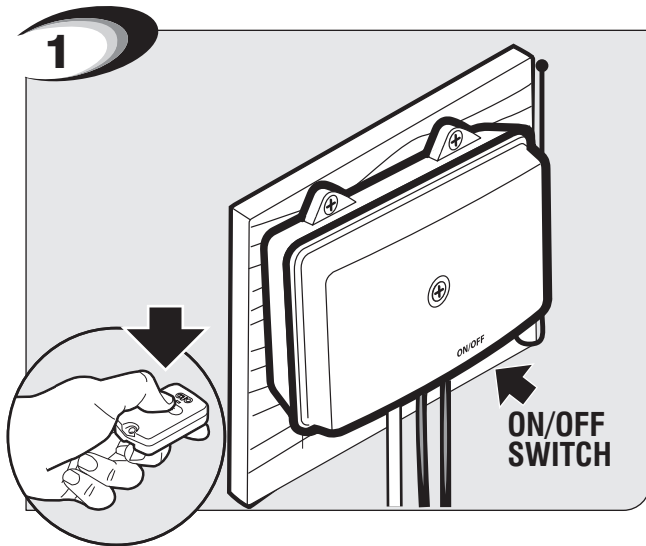

With gate in the open position, (arm retracted) turn the control box ON/OFF switch to the off position. Press and hold the transmitter while sliding the ON/OFF switch to the ON position and you will hear a series of beeps a pause then a single beep. At that point release the transmitter button. This process may take 8 - 10 seconds.

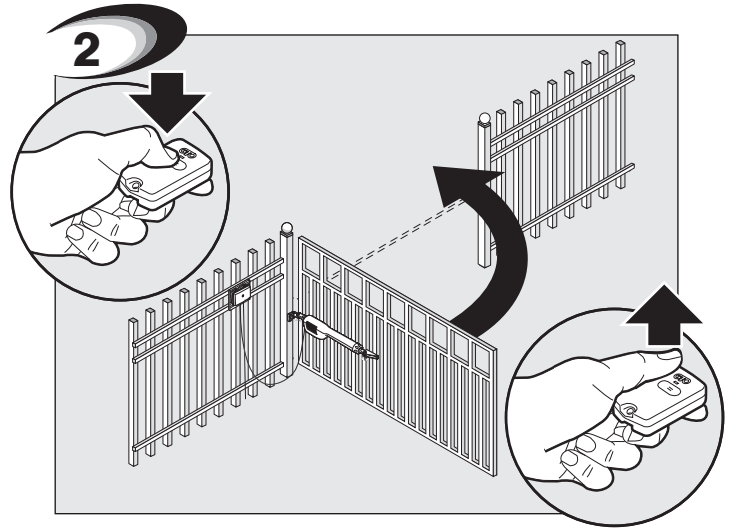

Press and hold transmitter; gate should start closing. Release transmitter button when gate reaches desired CLOSED position. NOTE: If your gate stops and reverses before it fully closes, you may need to increase the stall force. (See page 9)

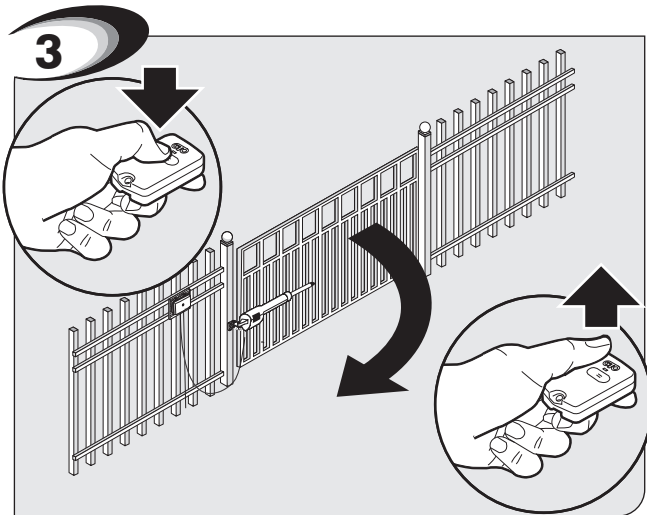

Press and hold transmitter again; gate should start opening. Release transmitter button when single audible alarm sounds indicating that gate has reached OPEN position.

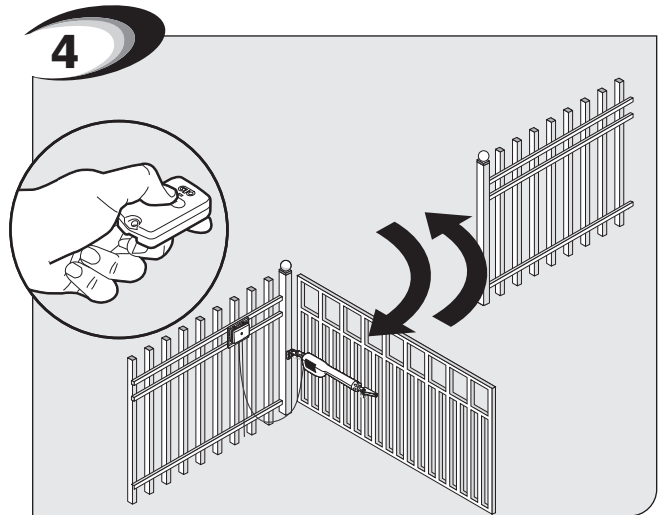

Gate operator's closed position is now set. Press and release transmitter to close gate for normal operation.

SETTING DUAL SENSE DETECTION & AUTO CLOSE TIMER

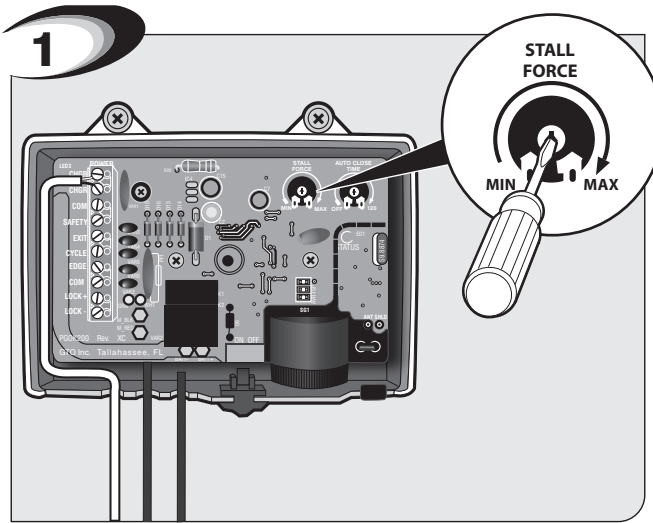

Do not use the Dual Sense Stall Force adjustment to compensate for a gate that is sticking or binding. Excessive Stall Force may cause damage to the gate operator or gate system or Injury or Death.

The Stall Force adjustment controls the amount of force the opener will apply against an obstruction before it stops and reverses direction. The adjustment on the control board operates like a volume control on a radio. It controls the amount of force the opener will apply to an obstruction before it automatically reverses direction.

The Stall Force adjustment is located on the control board. Turn the "STALL FORCE" arrow in the center of the potentiometer with small flat head screwdriver. Adjust the sensitivity from the MINIMUM position up to the point where the gate operates without obstructing from its own weight or the wind conditions in your area.

You may need to increase the stall force in cold weather due to increased resistance from gate hinges. However, the adjustment must remain as near to minimum as possible and when the weather improves decrease the setting to the appropriate position.

NOTE: The stall force setting must at the lowest (minimum) possible position.

CAUTION

For safety reason the Dual Sense Stall Force setting on the Mighty Mule control board comes from the factory set at MIN (minimum). This setting may need adjustment depending on the size and weight of the gate.
ALWAYS KEEP SAFETY AT THE TOP OF YOUR LIST WHEN ADJUSTING OR SERVICING YOUR GATE SYSTEM.

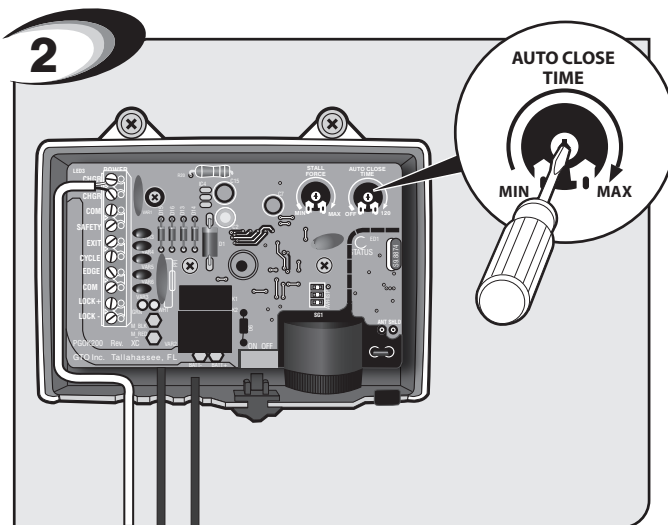

Turn the "AUTO CLOSE TIME" arrow in the center of the potentiometer with small flat head screwdriver to determine how long the gate will remain open before it automatically closes. The limits are OFF and 3 - 120 seconds. The factory setting is OFF.

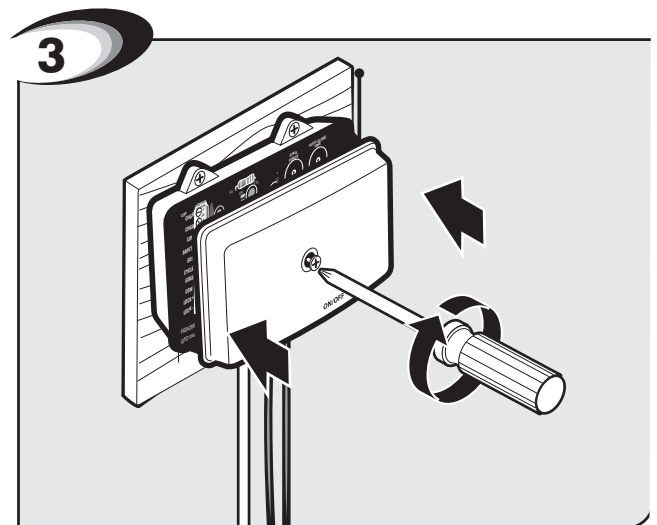

Close control box.

CONNECTING ADDITIONAL DEVICES

Mighty Mule strongly recommends the use of additional obstruction detection devices however we do not endorse any specific brand names. Only use products that are listed to be in compliance with any applicable UL safety standards and national and regional codes.

PLEASE NOTE: Contact sensors, non-contact sensors, shadow loops, etc. are not included with the Mighty Mule. Refer to the sensor manufacturer's instructions for information about installing accessory devices.

The Mighty Mule ONLY accepts accessory devices with normally open dry contact outputs.

⚠ WARNING

Make sure the operator power switch is turned OFF before connecting ANY device wiring to the terminals of the controller. Unplugging the transformer does not turn power to the operator off.

Wiring Accessories through Control Board Wiring Knockout

Remove control box cover.

Carefully remove wiring knockout (on cover) to insert accessory wires.

Insert accessory wires through the knockout and route to the accessory input terminals on the control board.
(See pg. 12)

Reattach control box cover.

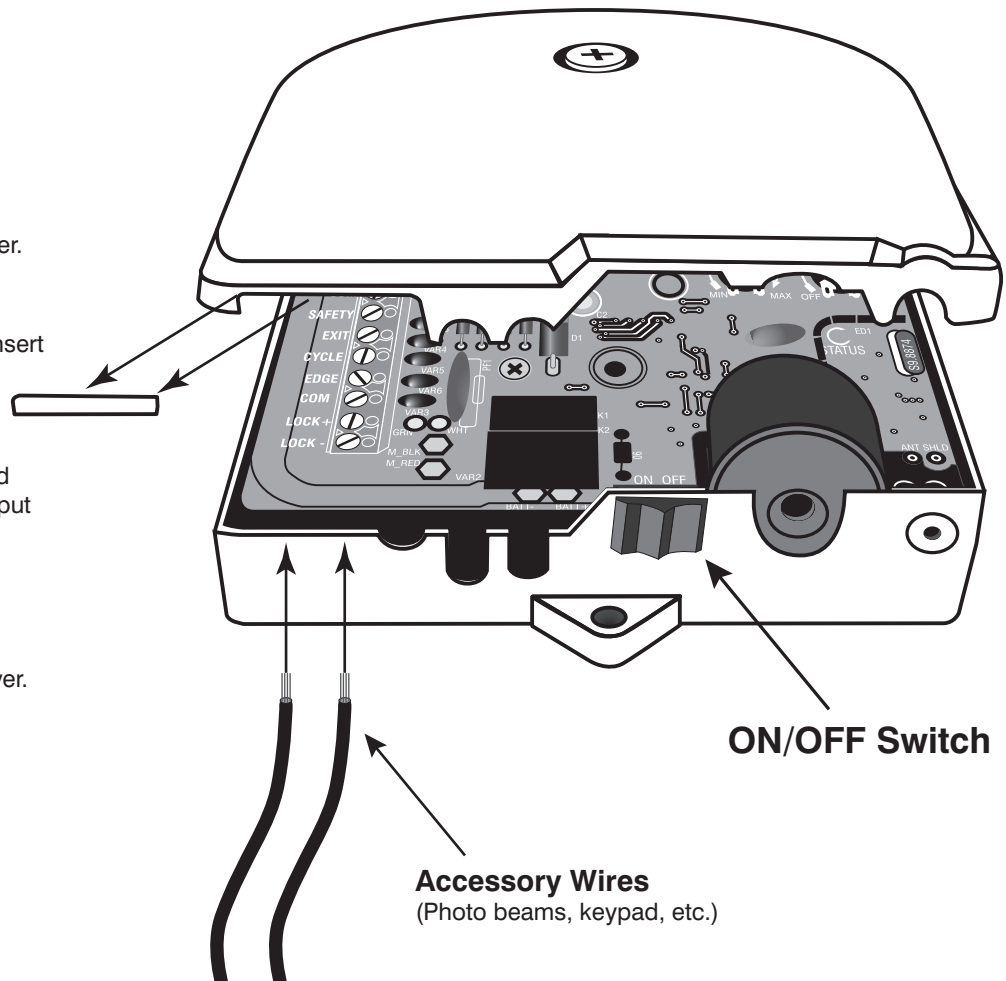

CONTROL BOARD CONNECTIONS

NOTE:

- All accessory inputs are dry-contact, normally open, inputs. DO NOT apply external voltage sources to these inputs.
- All accessory inputs are connected with respect to **COMMON** terminal.

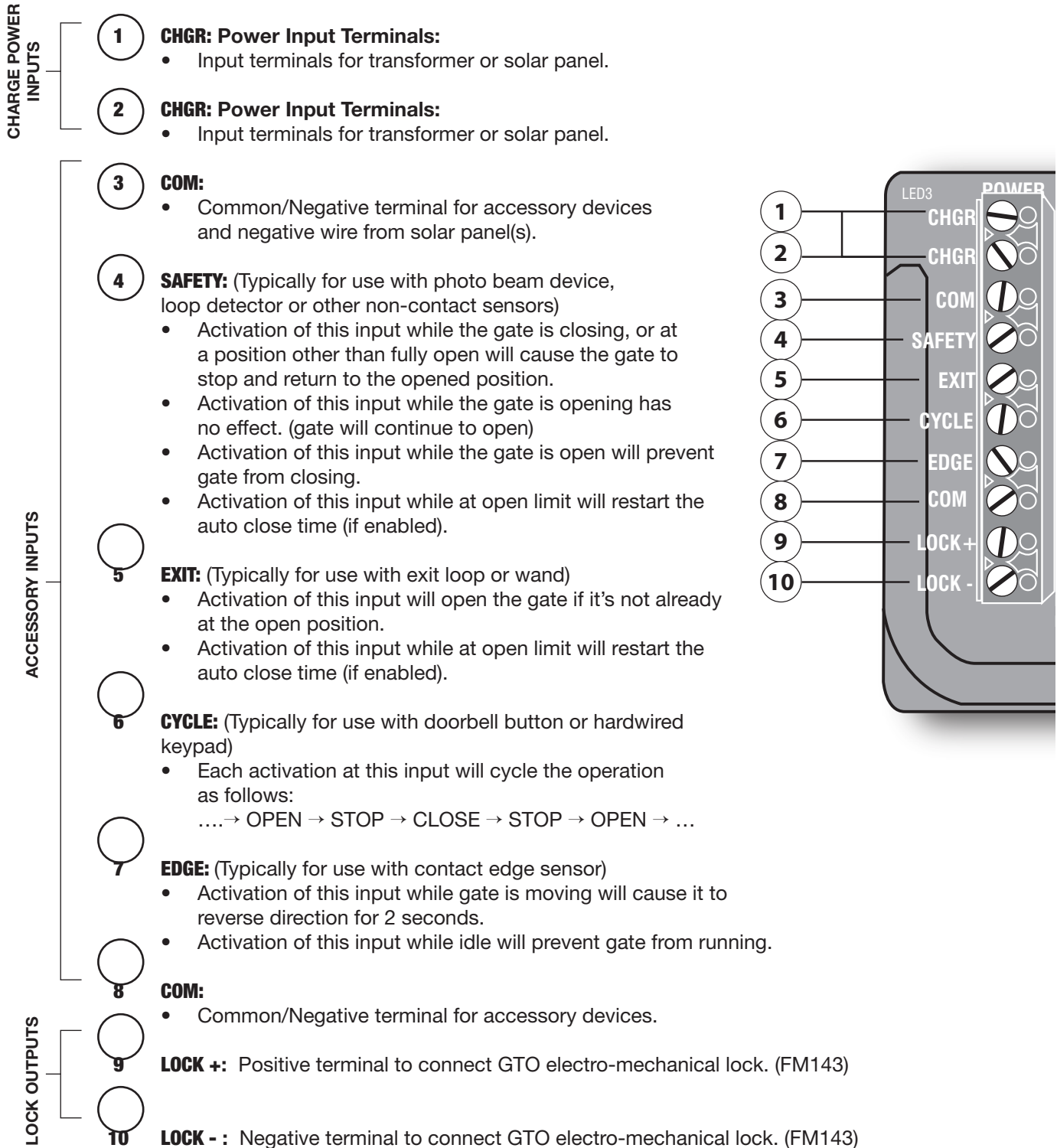

CONNECTING ACCESSORIES

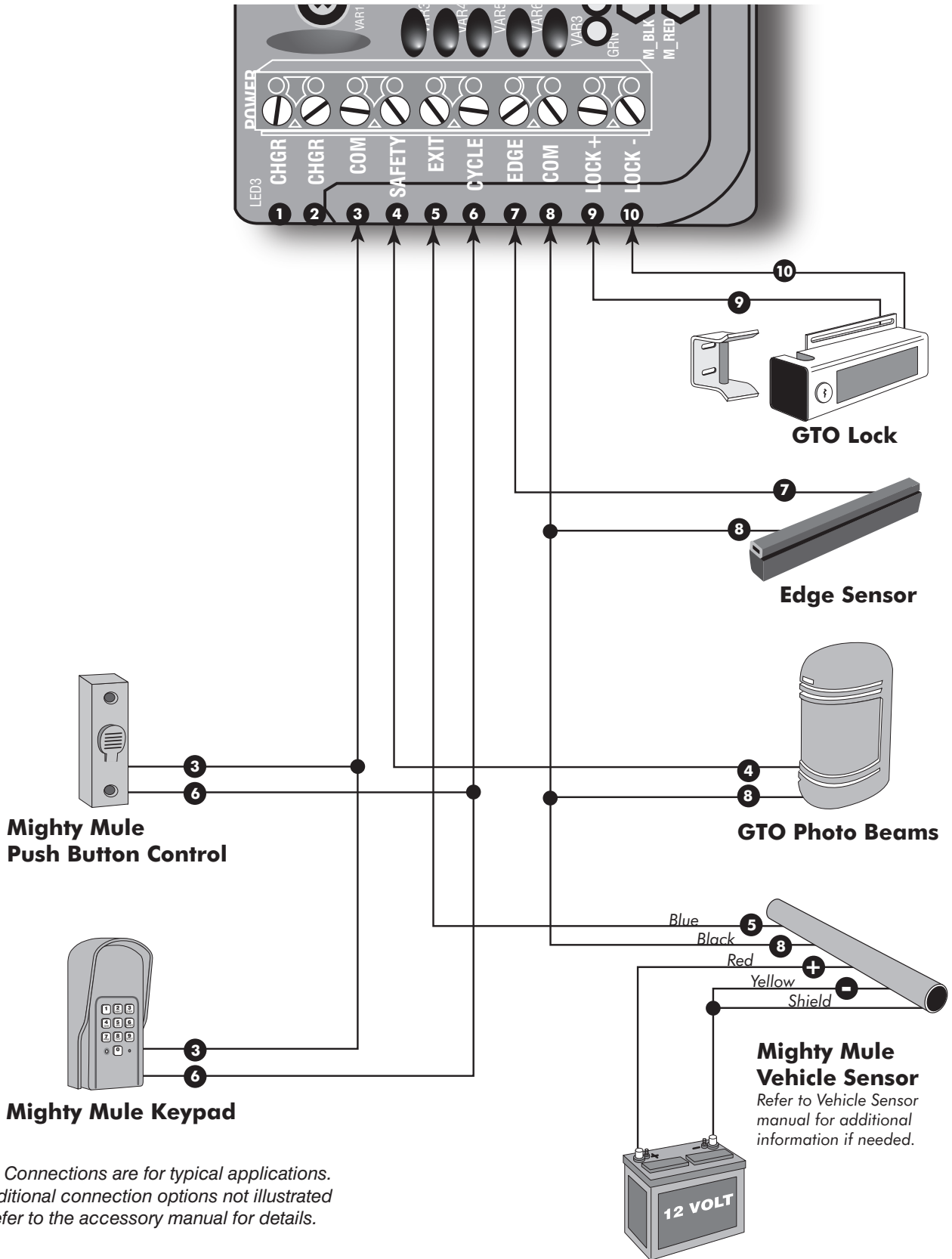

NOTE: Connections are for typical applications. For additional connection options not illustrated here refer to the accessory manual for details.

MAINTENANCE

Monthly, test the obstruction and entrapment protection systems.

Monthly, service the gate operator (make sure the power switch is OFF). Clean extended operator arm with a soft, dry clean cloth. After cleaning, apply a high quality silicon spray to a soft dry cloth and wipe the push/pull tube. DO NOT directly spray the tube!

On all gates weighing 250 lb. or more, routinely grease the ball bearing hinges at least 4 times a year; more frequently if the gates are near a coastal area.

Monthly, turn off the power switch and disconnect the Mighty Mule and move the gate to make sure the gate is moving freely without sticking or binding. Lubricate the hinges or repair the gate as required before reattaching the Mighty Mule.

Monthly, check the gate system for potentially entrapments from new landscaping or construction. Eliminate or guard as required.

Monthly, check that the warning signs are mounted on each side of the gate and clearly visible. Replace the signs if they are missing or damaged.

Replace batteries every 2-3 years and properly recycle old batteries.

TROUBLESHOOTING GUIDE

If your gate opener does not function properly after it is installed, use this guide before calling the GTO Service Department.

Audible Feedback

Symptom	Diagnosis	Check:
1 or more short beeps upon power up	Circuit Board Powered Up & Ready	<ul style="list-style-type: none"> • Normal Operation
Rapid beeping	Circuit Board Senses an Obstruction	<ul style="list-style-type: none"> • Path of Gate • Gate for Level and Plumb • Stall Force Adjustment • Disconnect Obstruction Detection Devices
1 beep every 20 seconds off	Low Battery Condition	<ul style="list-style-type: none"> • Transformer or Solar Panel Voltage • Charge the battery if solar conditions have been poor • Battery Harness Connections • Battery Under Load
2 beeps every 2 seconds	Position sensor is short circuit.	<ul style="list-style-type: none"> • Arm Power Cable for Damage
1 beep every 2 seconds off	Position sensor is open circuit.	<ul style="list-style-type: none"> • Arm Power Cable for Damage
1 beep when attempting to run the gate	Blown fuse Battery is low or damaged Loose Connection	<ul style="list-style-type: none"> • Check and replace fuse • Test battery voltage • Check all connections

Additional information can be found online 24 hours 7 days a week at the GTO Tech Wizard (support.gtoinc.com/Support/TroubleShooter.aspx)

TROUBLESHOOTING GUIDE

Visual Feedback

Symptom	Diagnosis	Check:
Power (green) ON	AC or Solar Power Present	Normal Operation
Power (green) OFF	No AC or Solar Power	Transformer: <ul style="list-style-type: none">• Breaker or GFI• Power at AC outlet.• Output of Transformer.• Voltage on wire at 18 VAC Input Solar: <ul style="list-style-type: none">• Solar Panel Wires Reversed• Weather• Solar Panel Placement• Output of Solar Panel• Voltage on wire at Solar Input

REPAIR SERVICE

If your Mighty Mule Gate Opener is not operating properly, please follow the steps below:

1. First use the procedures found in the Maintenance & Troubleshooting Guide (see page 13 and 14).
2. For 24 hour 7 days a week trouble shooting and support online go to our TECH WIZARD site at...
support.gtoinc.com/Support/TroubleShooter.aspx
3. If you are unable to solve the problem, call the **GTO Service Department** at (800) 543-1236, or (850) 575-4144. Refer to the serial number (located on the rear of control arm) and date of purchase when calling for assistance.
4. If repair or replacement of your gate opener is necessary, the Service Department will assign a **Return Goods Authorization (RGA)** number.
5. Include a copy of your receipt and securely pack the component(s) authorized for return to the factory. Write the RGA number issued to you on the outside of the package in **LARGE BOLD PRINT**. Ship the package(s) freight prepaid to: **GTO Access Systems, LLC • 3121 Hartsfield Road • Tallahassee, Florida • USA 32303**.

NOTE: Products returned to GTO without a Return Goods Authorization (RGA) number in LARGE BOLD PRINT on the outside of the package WILL NOT be accepted. Items returned to GTO freight collect WILL NOT be accepted. Items returned without proof of purchase will not be repaired under warranty.



For 24 hour 7 days a week trouble shooting and support online go to our TECH WIZARD site at...
support.gtoinc.com/Support/TroubleShooter.aspx

The Mighty Mule Technical Service Department is open
Monday – Friday 8:00 A.M. – 7:00 P.M. (Eastern Time)

Telephone (800) 543-1236

Fax (850) 575-8950 • Web site: www.mightymule.com

Conversion Chart

VOLTAGE READINGS

18 Vac Transformer _____ 18.0 to 22.0 Vac

5 W Solar panel (single) _____ 18.0 to 22.0 Vdc
measure voltage at panel and control box.

12 V Battery _____ 12.0 to 13.5 Vdc

Charging circuit _____ 12.0 to 14.8 Vdc
measure voltage with battery connected

Converting Metric Units to English Equivalents

When You Know	Multiply By	To Find	Symbol
centimeters	0.3937	inches	in. (or ")
meters	3.2808	feet	ft. (or')
kilograms	2.2046	pounds	lb. (or #)

Converting English Units to Metric Equivalents

When You Know	Multiply By	To Find	Symbol
inches	2.5400	centimeters	cm
feet	0.3048	meters	m
pounds	0.4535	kilograms	kg

Converting Temperature

deg. Celsius	$(^{\circ}\text{C} \times 1.8) + 32$	deg. Fahrenheit	$^{\circ}\text{F}$
deg. Fahrenheit	$(^{\circ}\text{F} - 32) \div 1.8$	deg. Celsius	$^{\circ}\text{C}$

For Your Records

Please record the product serial number (located on the right hand side of the control box), and the date and place of purchase in the spaces provided below. Refer to this information when calling GTO for service or assistance with your automatic gate opener.

Serial Number _____ Date of Purchase _____

Place of Purchase _____

Remember to keep all receipts for proof of purchase.



ACCESSORIES

Accessories are Available From Your Retail Store

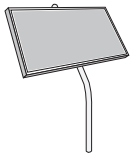

Solar Panel (FM121)

The Solar Panel is a 5 watt solar powered battery charger for use with the **Mighty Mule 260** gate operator systems. Particularly suited for remote installations, each **Solar Panel** comes with tubular steel support, mounting clips, wire connectors, and 10 ft. of low voltage wire (see Low Voltage Wire for additional wire). The **Mighty Mule** control board has clearly labeled terminal connections for easy installation of the **Solar Panel**. Installation in some regions of the world will require multiple solar panels for adequate charging power.



Push Button Control (FM132)

Unlit doorbell button for remote entry or exit control. Wires directly to the control board and uses 16 gauge stranded, dual conductor low voltage wire (sold separately).

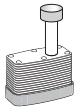

Pin Lock (FM133)

The **Pin Lock** substitutes for the clevis pin at the front end of the **Mighty Mule** gate openers. Helps prevent theft of the operator from the gate, while allowing quick release of the operator.



Key Chain Two Button Transmitter (FM134)

The **Key Chain Transmitter** is a dual button version of the **Mighty Mule** single button entry transmitter and has the same adjustable code settings. Used for 2 gates or 1 gate and garage door (when used with in conjunction with a garage door receiver – RB709U-NB). (battery is included)



Single Button Transmitter (FM135)

The **Mighty Mule** entry transmitter, with adjustable code settings, is standard equipment with all **Mighty Mule** systems. (battery is included)



Digital Keypad (FM137)

Allow friends access to your property using an identification code that you provide. Keypad can be programmed to use up to 25 different personal identification number (PIN) codes. Each code is face programmable with additional security features built in. Wired installations require 16 gauge, low voltage, stranded, dual conductor, direct burial wire (sold separately). Requires three AA batteries (not included).



Mounting Post (FM100) - In Ground

This black powder coated pedestal is designed to provide convenient access to your keypad, wireless intercom, or other access control device from your vehicle. With its break down design it is easy to install and works well in most standard applications. Surface Mount Flanges (F102) and Extensions (F103) for added height are available.

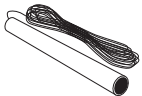

Mighty Mule Vehicle Sensor (FM138)

The **Gate Opening Sensor** is designed for residential and agricultural applications and is compatible with most **Mighty Mule** automatic gate opener models. The **Sensor** is an electromagnetic sensor, which offers 'hands free' operation of the **Mighty Mule** Gate Operator with a 12 ft. radius of detection of vehicles in motion.



Automatic Gate Lock Pull-to-Open (FM143)

A **MUST** for added security. Solenoid driven, with a steel housing. Used with **Mighty Mule** DC swing gate operating systems for maximum stability and security. Comes with a keyed manual release.

Accessories are Available From Your Retail Store (con't)



Wireless Entry Intercom / Keypad (FM136)

Allows owner to screen guest at the gate before allowing access to the property. Keypad also allows owner to give up to 25 programmable entry codes to family, friends or approved delivery personnel. Codes can be permanent or temporary. Up to 500 feet reception.

Additional base stations available (F3101MBC).



Low Voltage Wire (RB509)

The 16 gauge, stranded, dual conductor **Low Voltage Wire** is for connecting the AC powered transformer, or the **Solar Panel** to the control board. Also used for the connection of accessories, such as locks, keypads, push buttons and other wired control devices. This specially designed wire is UV treated, PVC coated and ready for direct burial. Available in 1000' rolls or special lengths.

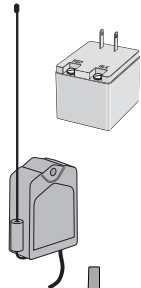

Replacement Transformer (RB570)

Standard 18 volt, 2260 mA, AC transformer for maintaining the battery with the **Mighty Mule** gate operator.



Garage Door Receiver (RB709U-NB)

The Garage Door Receiver allows you to use the same 2 button **Mighty Mule** entry transmitter to operate your gate operator and your garage door operator. Compatible with most garage door operators.

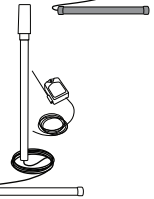

Driveway Alarm (FM231)

This device alerts you of vehicles entering your driveway (with or without an automated gate). The indoor base station signals you with a door chime when a vehicle passes the driveway sensor.

Wireless Driveway Vehicle Sensor (FM130)

Automatically activates gate operator "Hands-Free" when a vehicle exits the property. 100 ft. range between transmitter and receiver. Easy installation.

If you have a question about any special order item, call 1-800-543-4283

The contents of all material available on this installation manual are copyrighted by GTO Access Systems, LLC ("GTO"), unless otherwise indicated. All rights are reserved by GTO, and content may not be reproduced, downloaded, disseminated, published, or transferred in any form or by any means, except with the prior, written permission of GTO. Any reprinting of GTO publications is by permission only. Copyright infringement is a violation of federal law.

Mighty Mule®, E-Z Gate®, GTO®, "Dual Sense Technology" are registered trademarks of GTO Access Systems, LLC, America's DIY Automatic Gate Openers is a trademark of GTO Access Systems, LLC and are the exclusive property of GTO Access Systems, LLC ("GTO").

All rights are reserved by GTO, and these marks may not be used, in any for without the prior, written permission of GTO.

Gate Operator Installation Checklist

- 1. The gate has been checked to make sure it is level and moves freely in both directions.
- 2. Potential pinch areas have been guarded so as to be inaccessible OR have sensing edges and/or photo beam obstruction detection devices installed.
- 3. The installer has installed one or more contact or non-contact obstruction sensing devices, if required for this installation.
- 4. If pedestrian traffic is expected, a separate pedestrian gate has been installed, a minimum of seven feet from the gate system. All pedestrian traffic must use the pedestrian gate.
- 5. Warning signs have been installed on each side of the gate in highly visible locations. These signs must remain at all times.
- 6. There are no controls installed on the gate operator, or within 10 feet of the gate.
- 7. The Dual Sense Technology™ feature has been properly adjusted and tested to make sure that the gate stops and reverses a short distance with minimal resistance applied.
- 8. Reviewed and understand all of the operational functions, obstruction sensing devices, warning beeper and reset, etc.
- 9. Review and understand the proper use of the operator's manual disconnect feature. The manual disconnect must never be used while the gate is in motion. The power switch must be turned off before using the manual disconnect and disengaging the operator.
- 10. Reviewed all safety instructions, and keep the safety instructions and owner's information sheets for reference.
- 11. Review and understand the maintenance schedule for both the gate and the gate operator.



3121 Hartsfield Road • Tallahassee, Florida, USA 32303
Telephone Mighty Mule Sales: 1-800-543-4283 • Fax (850) 575-8912
or Mighty Mule Technical Service: 1-800-543-1236 • Fax (850)575-8950
www.mightymule.com