

# Installation Manual for the



## Automatic Gate Opener System FOR SINGLE SWING GATES

### **⚠ WARNING! ⚠**

This equipment is similar to other gate or door equipment and meets or exceeds Underwriters Laboratory Standard 325 (UL 325). However, gate equipment has hazards associated with its use and therefore by installing this product the installer and user accept full responsibility for following and noting the installation and safety instructions. Failure to follow installation and safety instructions can result in hazards developing due to improper assembly. You agree to properly install this product and that if you fail to do so GTO, Inc. shall in no event be liable for direct, indirect, incidental, special or consequential damages or loss of profits whether based in contract tort or any other legal theory during the course of the warranty or at any time thereafter. The installer and/or user agree to assume responsibility for all liability and use of this product releasing GTO, Inc. from any and all liability. If you are not in agreement with this disclaimer or do not feel capable of properly following all installation and safety instructions you may return this product for full replacement value.

**READ ALL INSTRUCTIONS CAREFULLY AND COMPLETELY before attempting to install and use this automatic gate opener. This gate opener produces a high level of force. Stay clear of the unit while it is operating and exercise caution at all times.**

**All automatic gate openers are intended for use on vehicular gates only.**

*This product meets and exceeds the requirements of UL 325, the standard which regulates gate opener safety, as established and made effective March 1, 2000, by Underwriters Laboratories Inc.*



3121 Hartsfield Road • Tallahassee, Florida, USA 32303  
Telephone GTO Sales: 1-800-543-GATE (4283) or (850) 575-0176 • Fax (850) 575-8912  
or GTO Technical Service: 1-800-543-1236 or (850) 575-4144 • Fax (850) 575-8950  
[www.mightymule.com](http://www.mightymule.com)

rev - 11/05/02

RB901

©2000 GTO, Inc.

The Mighty Mule Gate Opener® is intended for use with vehicular swing gates. The opener can be used in Class I, Class II and Class III applications.

### VEHICULAR GATE OPENER CLASS CATEGORIES

**Residential Vehicular Gate Opener-Class I:** A vehicular gate opener (or system) intended for use in a home of one-to-four single family dwelling, or a garage or parking area associated therewith.

**Commercial/General Access Vehicular Gate Opener-Class II:** A vehicular gate opener (or system) intended for use in a commercial location or building such as a multifamily housing unit (five or more single family units), hotel, garages, retail store, or other building servicing the general public.

**Industrial/Limited Access Vehicular Gate Opener-Class III:** A vehicular gate opener (or system) intended for use in an industrial location or building such as a factory or loading dock area or other locations not intended to service the general public.

**Restricted Access Vehicular Gate Opener-Class IV:** A vehicular gate opener (or system) intended for use in a guarded industrial location or building such as an airport security area or other restricted access locations not servicing the general public, in which unauthorized access is prevented via supervision by security personnel.

### Conversion Chart

#### *Converting Metric Units to English Equivalents*

<b>When You Know</b>	<b>Multiply By</b>	<b>To Find</b>	<b>Symbol</b>
centimeters	0.3937	inches	in. (or ")
meters	3.2808	feet	ft. (or')
kilograms	2.2046	pounds	lb. (or #)

#### *Converting English Units to Metric Equivalents*

<b>When You Know</b>	<b>Multiply By</b>	<b>To Find</b>	<b>Symbol</b>
inches	2.5400	centimeters	cm
feet	0.3048	meters	m
pounds	0.4535	kilograms	kg

#### *Converting Temperature*

deg. Celsius	$(^{\circ}\text{C} \times 1.8) + 32$	deg. Fahrenheit	$^{\circ}\text{F}$
deg. Fahrenheit	$(^{\circ}\text{F} - 32) \div 1.8$	deg. Celsius	$^{\circ}\text{C}$

### FOR YOUR RECORDS

Please record the product serial number (located on the control box cover), and the date and place of purchase in the spaces provided below. Refer to this information when calling GTO for service or assistance with your automatic gate opener.

**Serial Number** \_\_\_\_\_ **Date of Purchase** \_\_\_\_\_

**Place of Purchase** \_\_\_\_\_

*Remember to keep all receipts for proof of purchase.*

# Table of Contents

Gate Opener Class Categories .....	inside cover
Units and Standards Conversion Chart .....	inside cover
<b>PLEASE READ THIS FIRST! .....</b>	<b>page iii</b>
<b>Important Safety Instructions .....</b>	<b>page 1</b>
Disconnecting the Opener .....	page 1
Important Safety Instructions for the Consumer .....	page 2
Secondary Means of Protection Against Entrapment .....	page 5
Required Safety Precautions for Gates .....	page 6
Warning Signs and Labels .....	page 7
<b>Installation .....</b>	<b>page 8</b>
Parts List .....	page 8
Technical Specifications .....	page 10
Installation Overview .....	page 11
Installation of the Mounting Hardware .....	page 12
Mounting the Opener .....	page 16
Installation of the Positive Stops .....	page 16
Mounting the Control Box .....	page 18
Setting the Closed Position .....	page 19
<b>Powering the System .....</b>	<b>page 20</b>
Solar Chart .....	page 20
Connecting the Transformer .....	page 22
<b>Control Board Settings .....</b>	<b>page 23</b>
DIP Switches .....	page 23
Potentiometers .....	page 24
<b>Setting Your Personal Transmitter Code .....</b>	<b>page 25</b>
<b>Mounting the Receiver .....</b>	<b>page 26</b>
<b>Connecting Additional Safety Devices .....</b>	<b>page 27</b>
<b>Connecting Accessories .....</b>	<b>page 28</b>
<b>Push to Open Installation .....</b>	<b>page 29</b>
<b>Maintenance &amp; Troubleshooting Guide .....</b>	<b>page 31</b>
<b>Warranty and Repair Service .....</b>	<b>page 33</b>
<b>Column Installation Information .....</b>	<b>page 34</b>
<b>Accessory Catalog .....</b>	<b>page 35</b>
<b>4 1/2" x 4 1/2" Setback Template .....</b>	<b>insert</b>

**KEEP THESE INSTRUCTIONS FOR FUTURE REFERENCE**



## PLEASE READ THIS FIRST!

Thank you for purchasing a **Mighty Mule E-Z Gate Opener**—GTO's "do-it-yourself" automatic gate opener! When correctly installed and properly used, your **Mighty Mule E-Z Gate Opener** will give you many years of reliable service. Please read the following information and watch the enclosed videotape to ensure you have the correct system for your particular needs. Furthermore, this manual and the videotape will enable you to properly install your **Mighty Mule E-Z Gate Opener**.

The **Mighty Mule E-Z Gate Opener** is designed for installation on a **pull-to-open single leaf gate** (gates that open *into* the property). Using an *accessory bracket*, the **Mighty Mule E-Z Gate Opener** can accommodate a **push-to-open single leaf gate** (gates that open *out* from the property). The gate must not exceed 16 feet in length nor weigh more than 350 pounds (please see *Technical Specifications* on page 10). The **Mighty Mule E-Z Gate Opener** can be used on vinyl, aluminum, chain link, farm tube, and wrought iron gates. Use on solid (wood) gates is not recommended. Solid surface gates have a high resistance to the wind; if the wind is strong enough, the opener will obstruct and stop.

The **Mighty Mule E-Z Gate Opener** accommodates extra transmitters, digital keypads, solar panels, push buttons, automatic gate locks, and other access control products. These optional accessories (see the enclosed *Mighty Mule Accessory Catalog*) are available at most stores. Your store should be able to special order any accessory not in stock. If your store cannot special order accessories, please call the GTO Sales Department.

The **Mighty Mule E-Z Gate Opener** features **adjustable obstruction sensing**. This safety feature makes the gate stop and reverse direction within 2 seconds when it comes in contact with an obstruction. **MIN** is the factory setting; meaning the gate will exert the minimum force on an obstruction before it stops and reverses direction.

The **Mighty Mule E-Z Gate Opener** also has an **adjustable auto-close feature**. After the gate reaches the fully open position, it can be set to remain open for 1 to 120 seconds before automatically closing. Pressing the transmitter button at any time after the gate opens fully will cause it to close immediately. **OFF** is the factory setting; meaning the gate will stay open until you press the transmitter (or keypad, etc.) again.

**PLEASE NOTE**—If your application requires any of the following:

- Swing gates longer than 16 feet or weighing more than 350 pounds;
- Slide gates;
- Heavy duty or commercial uses;
- Professional installation;

please call GTO at **(800) 543-GATE [4283]** or **(850) 575-0176** for information about our **GTO/PRO** professional line of gate openers and accessories. Our Sales Department will be glad to give you the name and phone number of a **GTO/PRO** dealer near you.

**BEFORE YOU BEGIN TO INSTALL YOUR AUTOMATIC GATE OPENER:  
watch the enclosed videotape and read these instructions *carefully and completely*  
to become familiar with all parts and installation steps.**

# ⚠ IMPORTANT SAFETY INSTRUCTIONS ⚠

Because automatic gate openers produce high levels of force, consumers need to know the potential hazards associated with improperly designed, installed, and maintained gate opener systems. **Keep in mind that the gate opener is just one component of the total gate operating system.** Each component must work in unison to provide the consumer with convenience, security, and safety.

This manual contains various safety precautions and warnings for the consumer. Because there are many possible applications of the gate opener, the safety precautions and warnings contained in this manual cannot be completely exhaustive in nature. They do, however, provide an overview of the safe design, installation, and use of this product. **CAREFULLY READ AND FOLLOW ALL SAFETY PRECAUTIONS, WARNINGS, AND INSTALLATION INSTRUCTIONS TO ENSURE THE SAFE SYSTEM DESIGN, INSTALLATION, AND USE OF THIS PRODUCT.**

Precautions and warnings in this manual are identified with this ⚠ warning symbol. The symbol identifies conditions that can result in damage to the opener or its components, serious injury, or death.

Because GTO automatic gate openers are *only part* of the total gate operating system, it is the responsibility of the consumer to ensure that the total system is safe for its intended use.

## To Manually Open and Close the Gate, Follow the Procedure Below:

### Disconnecting the Opener

1. Turn control box power switch **OFF**.
2. Remove hairpin clip, clevis pin, and washer from front mount.
3. Pull front mount away from gate bracket.

*The gate can be opened and closed manually when the opener is disconnected.*

**NOTE:** Substitute **Pin Locks** for the clevis pins to prevent unauthorized removal of the opener from the gate (*see Accessory catalog*).

**⚠ CAUTION: Disconnect the opener ONLY when the control box power switch is OFF and the gate is NOT moving.**

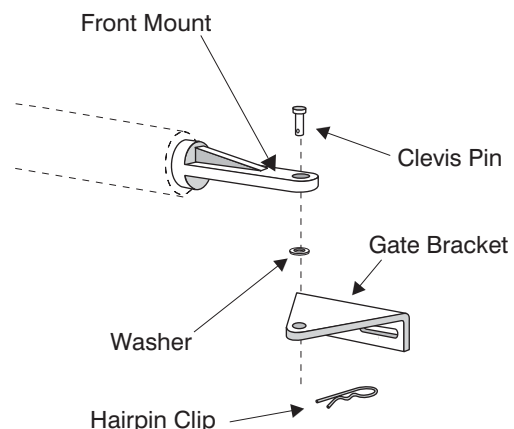

# ⚠ IMPORTANT SAFETY INSTRUCTIONS ⚠

## For The Consumer

### WARNING: To reduce the risk of injury or death:

1. **READ AND FOLLOW ALL INSTRUCTIONS.** Failure to meet the requirements set forth in the instruction manual could cause severe injury and/or death, for which the manufacturer cannot be held responsible.
2. When designing a system that will be entered from a highway or main thoroughfare, make sure the system is placed far enough from the road to prevent traffic congestion.
3. The gate must be installed in a location that provides adequate clearance between it and adjacent structures when opening and closing to reduce the risk of entrapment. Swinging gates **must not** open into public access areas.
4. The gate and gate opener installation **must comply with any applicable local codes.**

### I. Before Installation

1. Verify this opener is proper for the type and size of gate, its frequency of use and the proper class rating.
2. Make sure the gate has been properly installed and swings freely in both directions. Repair or replace all worn or damaged gate hardware prior to installation. A freely moving gate will require less force to operate and will enhance the performance of the opener and safety devices used with the system.
3. Review the operation of the system to become familiar with its safety features. Understand how to disconnect the opener for manual gate operation (*see page 1*).
4. This gate opener is intended for vehicular gates **ONLY**. A separate entrance or gate must be installed for pedestrian use (*see page 6*).
5. Always keep people and objects away from the gate and its area of travel. **NO ONE SHOULD CROSS THE PATH OF A MOVING GATE.**
6. Pay close attention to the diagram below and be aware of these areas at all times.

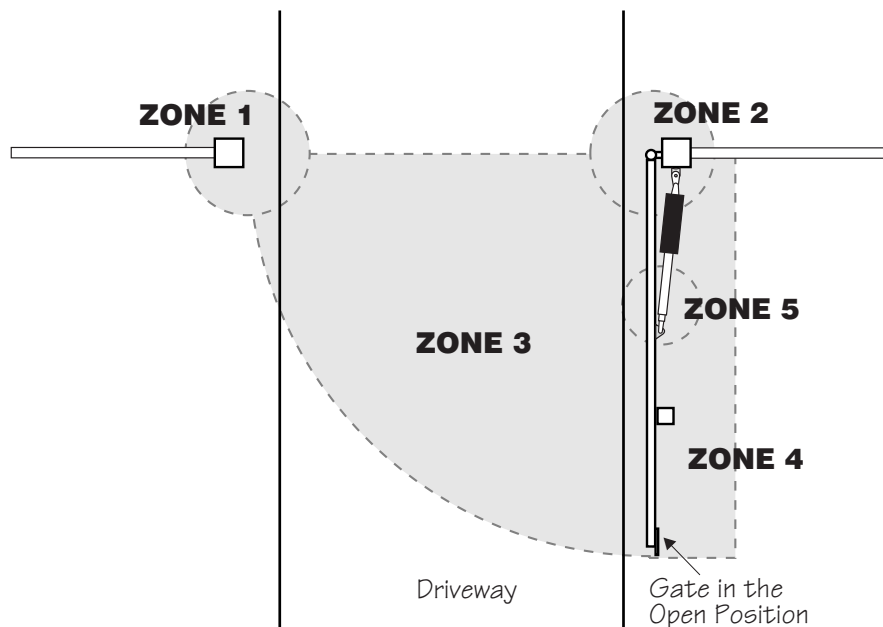

# ⚠ IMPORTANT SAFETY INSTRUCTIONS ⚠

## Entrapment Zones:

- Zone 1 – leading edge of the gate and the fence post.
- Zone 2 – between the gate and the gate post
- Zone 3 – the path of the gate
- Zone 4 – the space between the gate in the open position and any object such as a wall, fence, tree, etc.
- Zone 5 – pinch points between the opener and gate or post

## II. During Installation

1. Install the gate opener on the inside of the property and fence line. **DO NOT** install an opener on the outside of the gate where the public has access to it.
2. Be careful with moving parts and avoid close proximity to areas where fingers or hands could be pinched.
3. Devices such as safety edges and photo beams provide additional protection against entrapment (*see page 5*).
4. If push buttons or key switches are installed, they should be within sight of the gate, yet located at least 10 feet from any moving part of the gate (see diagram below). ***Never install any control device where a user will be tempted to reach through the gate to activate the gate opener.***
5. Do not activate your gate opener unless you can see it and can determine that its area of travel is clear of people, pets, or other obstructions. Watch the gate through its entire movement.
6. Secure outdoor or easily accessed gate opener controls in order to prohibit unauthorized use of the gate.

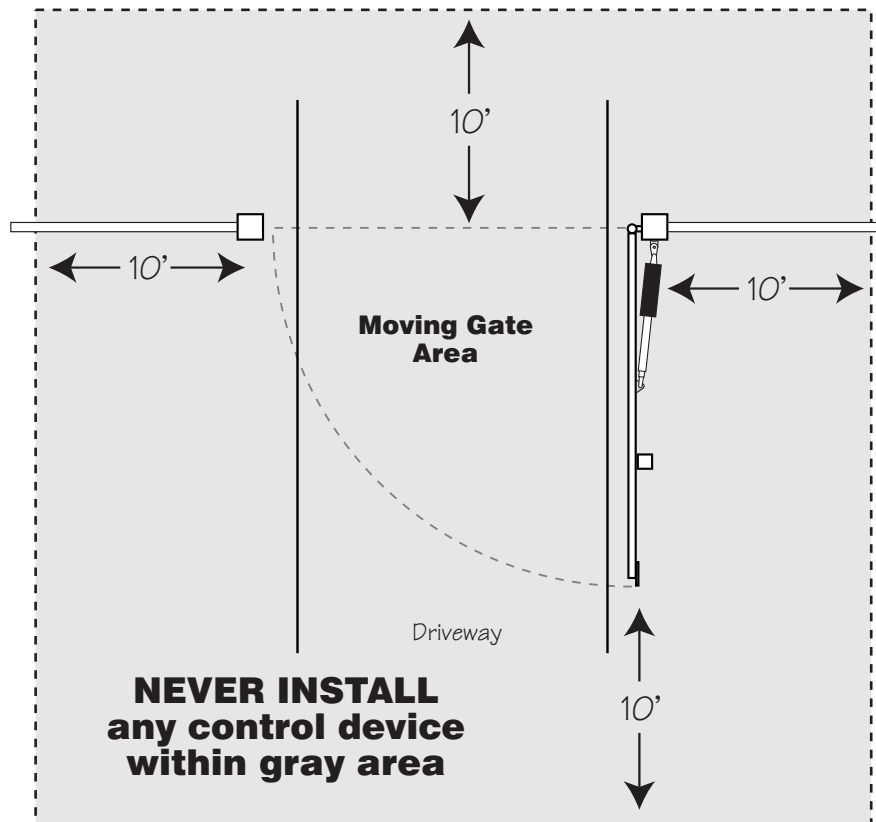

# **IMPORTANT SAFETY INSTRUCTIONS**

## III. After Installation

1. Attach the **warning signs** (*included*) to each side of the gate to alert the public of automatic gate operation. It is *your responsibility* to post warning signs on both sides of your gate. If any of these signs or warning decals become damaged, illegible or missing, replace them immediately. Contact GTO for free replacements.
2. The gate is automatic and could move at any time, posing a serious risk of entrapment. No one should be in contact with the gate when it is moving or stationary.
3. Do not attempt to drive into the gate area while the gate is moving; wait until the gate comes to a complete stop.
4. Do not attempt to "beat the gate" while the gate is closing. This is extremely dangerous.
5. Do not allow children or pets near your gate. **Never let children operate or play with gate controls.** Keep the remote controls away from children and unauthorized users; store controls where children and unauthorized users do not have access to them.
6. **KEEP GATES PROPERLY MAINTAINED.** Always turn power to opener OFF before performing any maintenance. Clean the push-pull tube with a soft, dry cloth and apply silicone spray to it at least once per month.
7. Service the gate and gate opener regularly. Grease hinges, spray push pull tube with high quality silicon spray and replace the battery every 3-5 years.
8. To operate this equipment safely, YOU must know how to disconnect the opener for manual gate operation (*see page 1*). If you have read the instructions and still do not understand how to disconnect the opener, contact the GTO Service Department.
9. Disconnect the opener **ONLY** when the power is **TURNED OFF** and the gate is **NOT** moving.
10. Make arrangements with local fire and law enforcement for emergency access.
11. Distribute and discuss copies of the **IMPORTANT SAFETY INSTRUCTIONS** section of this manual with all persons authorized to use your gate.
12. **IMPORTANT: Save these safety instructions. Make sure everyone who is using or will be around the gate and gate opener are aware of the dangers associated with automated gates. In the event you sell the property with the gate opener or sell the gate opener, provide a copy of these safety instructions to the new owner.**

**Should you lose or misplace this manual, a copy can be obtained by downloading one from the Mighty Mule web site ([www.mightymule.com](http://www.mightymule.com)), by contacting GTO, Inc., at 3121 Hartsfield Road, Tallahassee, Florida 32303 or by calling 1-800-543-4283 and requesting a duplicate copy. One will be provided to you free of charge.**



# ⚠ IMPORTANT SAFETY INSTRUCTIONS ⚠

## Secondary Means of Protection Against Entrapment

As specified by Gate Operator Safety Standard, UL 325 (30A.1.1), automatic gate openers shall have an inherent entrapment sensing system, and shall have *provisions for, or be supplied with*, at least one independent secondary means to protect against entrapment. The Mighty Mule utilizes **Type A**, an inherent (i.e., built-in) entrapment sensing system as the **primary** type of entrapment protection. Also, the Mighty Mule has *provisions for* the connection of **Type B2** protection to be used as the **secondary** type of entrapment protection, if desired.

1. For gate operators utilizing a contact sensor (e.g., safety edge sensor– Type B2) in accordance with UL 325 (51.8.4 [i]):
  - A. One or more contact sensors shall be located at the leading edge, bottom edge, and post edge, both inside and outside of a vehicular swing gate system.
  - B. A hard wired contact sensor shall be located and its wiring arranged so that the communication between the sensor and the gate opener is not subjected to mechanical damage.
  - C. A wireless contact sensor such as one that transmits radio frequency (RF) signals to the gate opener for entrapment protection functions shall be located where the transmission of the signals are not obstructed or impeded by building structures, natural landscaping or similar obstruction. A wireless contact sensor shall function under the intended end-use conditions.

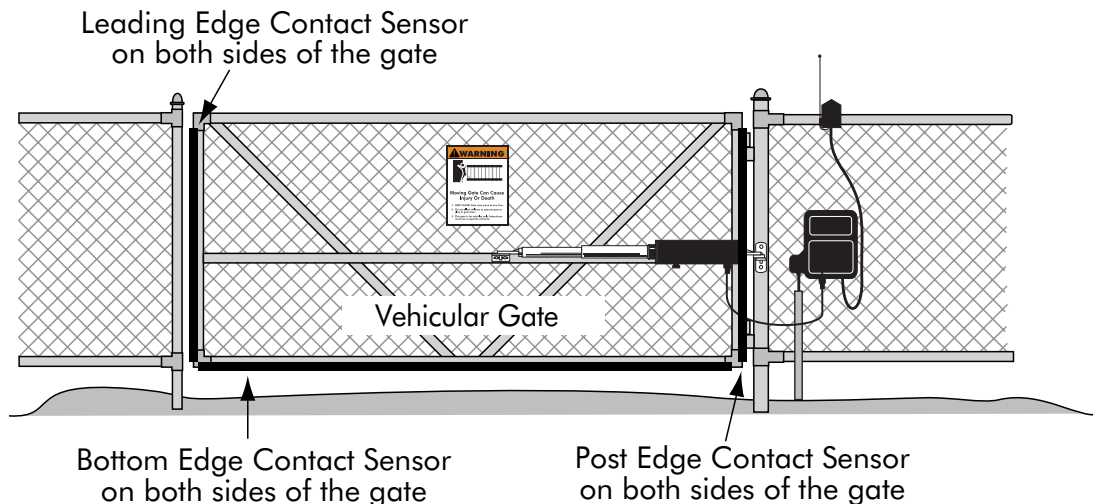

### **ENTRAPMENT ALARM (UL 325; 30A.1.1A)**

The Mighty Mule E-Z Gate Opener is designed to stop and reverse within 2 seconds when the gate comes in contact with an obstruction or when an object activates the non-contact sensors. Additionally, these openers are equipped with an **audio entrapment alarm** which will activate if the unit obstructs *twice* while opening or closing. This alarm will sound for a period of 5 minutes, or until the opener receives an intended signal (e.g., from a transmitter) and the gate returns to a fully open or fully closed position.

# IMPORTANT SAFETY INSTRUCTIONS

## Required Safety Precautions for Gates Install Warning Signs

**Warning signs** alert people of automatic gate operation and are **required** when installing the Mighty Mule E-Z Gate Opener. Furthermore, a walk-through gate must be installed if pedestrian traffic is expected near the vehicular gate. We recommend using the **GTO Bulldog Pedestrian Gate Lock** (Call the GTO Sales Department) for controlled access.

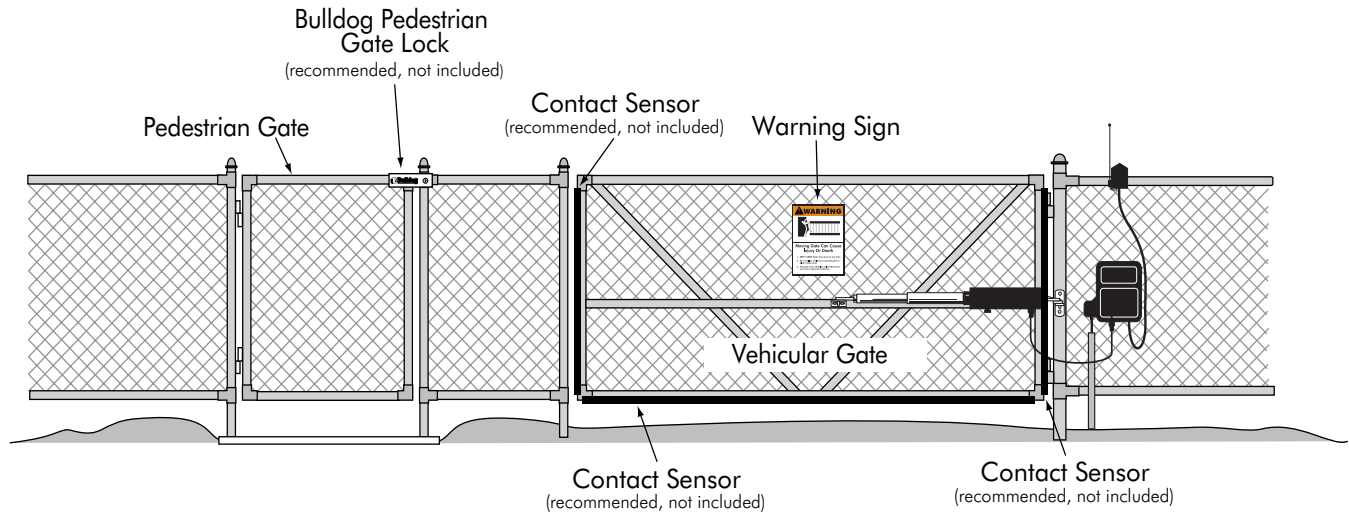

## Entrapment Protection

GTO's inherent obstruction settings, even when properly adjusted, *may not be sensitive enough to prevent bodily injury in some circumstances*. For this reason, safety devices such as safety edge sensors (or photoelectric sensors), which stop and reverse gate direction upon sensing an obstruction, are suggested for augmented protection against entrapment.

## Warning Signs

The warning signs (*at right*) must be installed on both sides of the gate (*see page 7 for details*).



# ! IMPORTANT SAFETY INSTRUCTIONS !

These warning labels should be found at the locations specified below. If any of them are missing, immediately contact GTO for replacements.



*warning signs (2 enclosed) to be installed on each side of the gate (3–5 feet above the bottom of the gate)*



*warning labels (2) installed on each side of operator housing*



**GTO-1000 Series**  
**Conforms to UL 325 STANDARDS**  
Maximum Gate: 500 lb. (226.7 kg); 16 ft. (4.8 m)  
Voltage: 12 Vdc; Frequency: 0 Hz; Power: 41.4 W  
Class I, II and III Vehicular Swing Gate Operator.  
Serial Number: XXXXXXXXXXXX

---

**TO MANUALLY OPEN AND CLOSE THE GATE:**

1. Turn control box power switch OFF.
2. Disconnect front mount from gate bracket.
3. Pull front mount away from gate bracket.

**Disconnect operator ONLY when the control box power switch is OFF and the gate is NOT moving.**

GTO, Inc. Tallahassee, Florida USA RB2000

*product identification and manual operation instruction label (1) installed on control box cover*

# Single Gate Opener Parts List

## Opener and Mounting Hardware

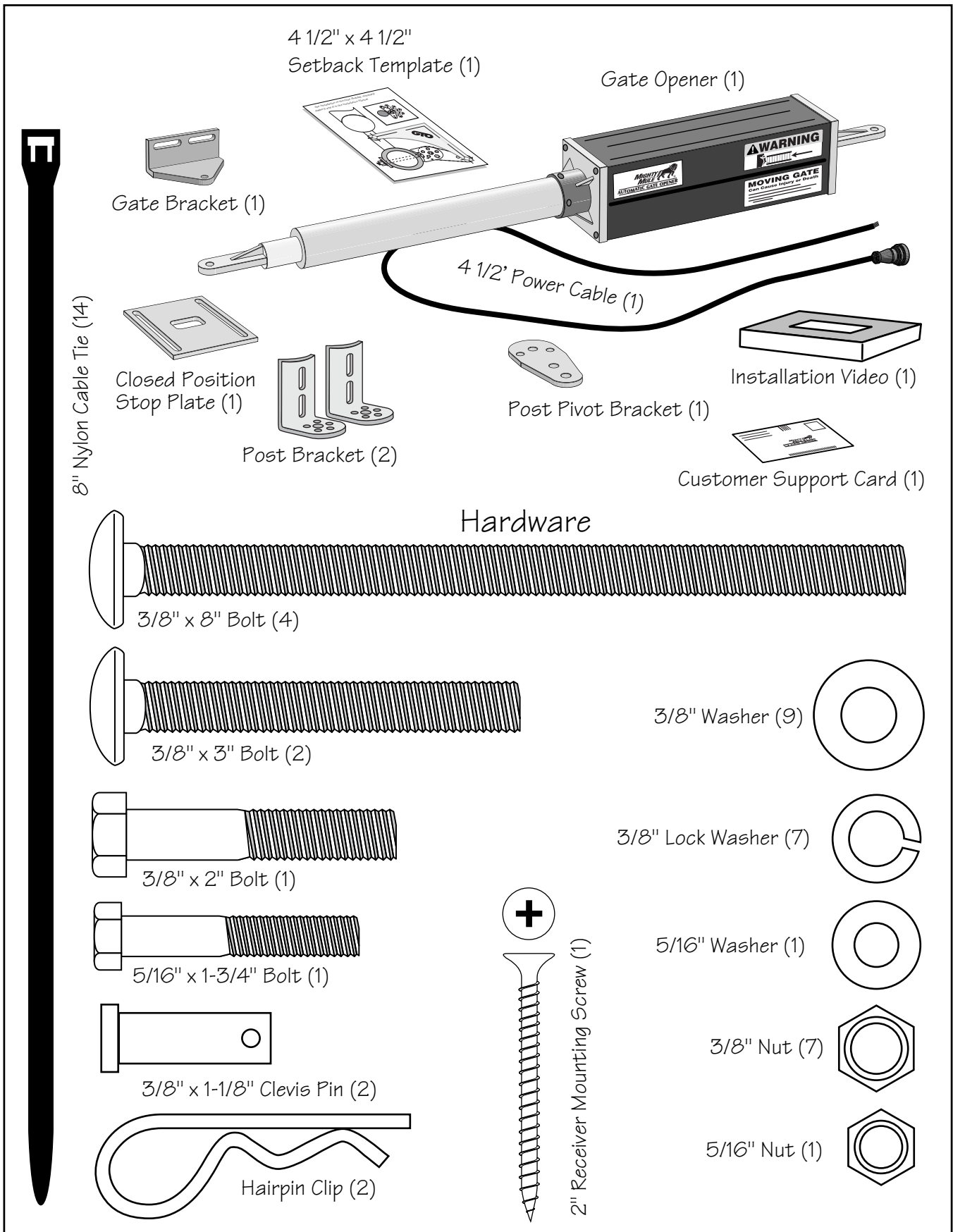

# Single Gate Opener Parts List (continued)

## Control Box and Electrical Components

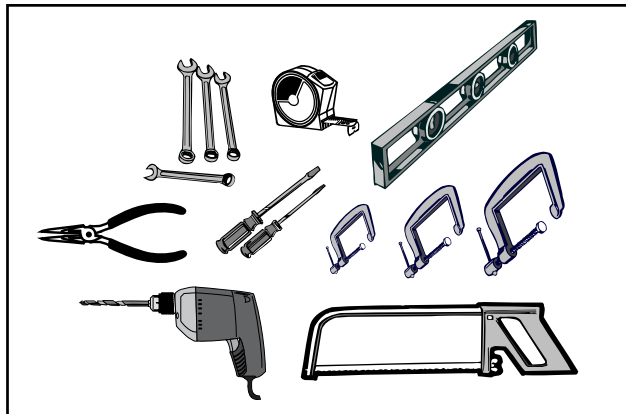
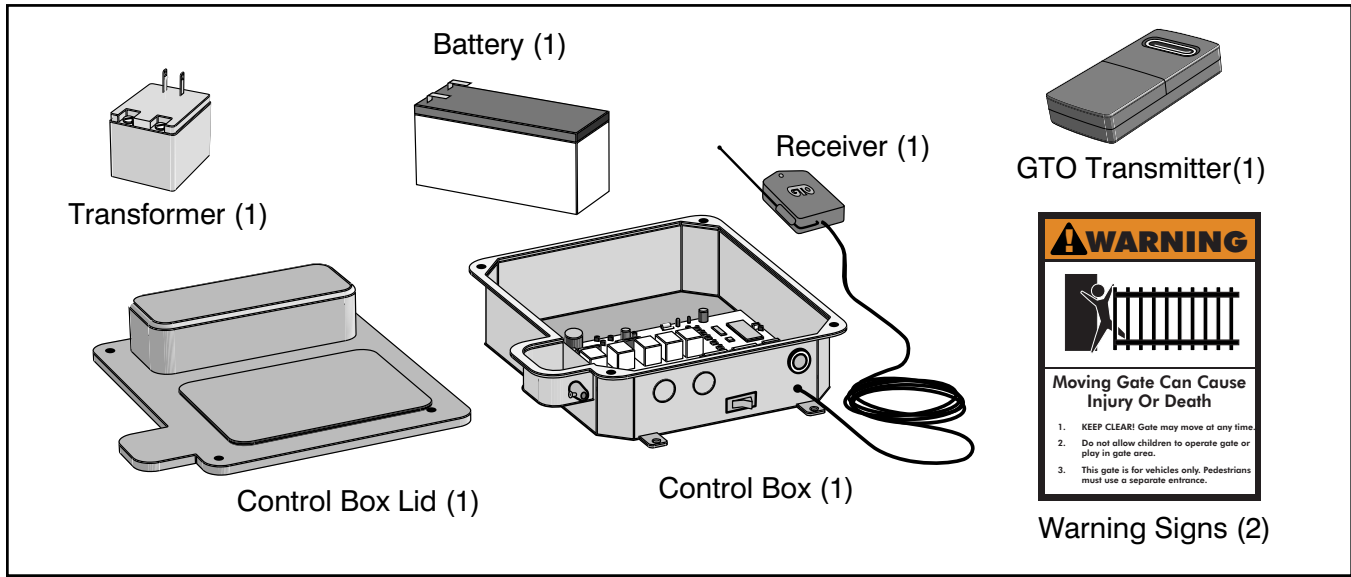

### Tools Needed

- Power Drill
- Open End Wrenches — 3/8", 7/16", 1/2", and 9/16"
- 3/8" Drill Bit
- Hacksaw or Heavy Duty Bolt Cutters
- Slotted (Flat Bladed) Screwdriver
- Phillips Screwdriver
- Tape Measure
- Level
- Wire Strippers
- C-Clamps — small, medium, and large

**ALSO, YOU WILL NEED THESE ITEMS BEFORE YOU BEGIN THE INSTALLATION (Some of these items can be found in the *Accessory Catalog* on page 35):**

- The gate needs a **stop post** for the open position. This post is not provided. See **Installation of the Positive Stops** on page 16 for more information.
- Additional **low voltage wire** may be needed; length depends upon the distance between the transformer power supply and the control box. See **Powering the System** on page 20, and the *Accessory Catalog*.
- If your gate is more than 1000' away from an ac power source you will need to use at least one **Mighty Mule Solar Panel** to trickle charge the battery. See the *Accessory Catalog*.
- If your fence post is made of wood and is less than 6" in diameter or 6" square, see page 12.
- If your fence post is larger than 6" in diameter you will need **threaded rods or carriage bolts longer than 8"**. See page 15.
- If you have thin walled tube or panel gates, see **Recommended Reinforcement Examples** on page 12.
- Depending on the type of gate, a **horizontal cross member or mounting plate may be needed** to mount the front of the opener and gate bracket to the gate. See page 11, step 2; page 15, step 10.
- **Power cables 40' long** are available for mounting your control box away from the gate (i.e., in a more secure location). See the *Accessory Catalog*.

# Technical Specifications

## MIGHTY MULE GATE OPENER

### DRIVE

- Low friction screw drive (linear actuator) rated for -20 °F to +160 °F (-28 °C to +71 °C).
- Powered by a 12 V motor with integral case hardened steel gear reducer. Motor speed reduced to 220 rpm. Generates 330 ft.. lb. of torque at 12 V.
- Maximum opening arc of 110°. Approximate opening time (90°): 15 to 17 s, depending on weight of gate.

### POWER

- The system is powered by a 12 Vdc, 7.0 Ah, sealed, rechargeable acid battery.
- Battery charge is maintained by a 120 Vac, 18 Vac output transformer rectified to 14.5 Vdc (20 VA) through the GTO control board. Two (2) blade-style control board fuses are rated for 15 A.

**NOTE: The transformer should not be directly connected to any battery. Do not replace fuses with higher ampere rated fuses; doing so will void your warranty and may damage your control board.**

- Battery charge is maintained by GTO Solar Panel Charger: float voltage of 14.5 Vdc output from a 19<sup>3</sup>/<sub>8</sub>" x 8<sup>1</sup>/<sub>2</sub>" silicon alloy panel. Generates minimum of 5 W at 300 mA. A gated diode on the control board prevents battery discharge.

### CONTROL

- GTO microprocessor-based control board is set for single leaf, pull-to-open gate installations. DIP switches can be adjusted to accommodate an optional kit for push-to-open gates (*see Accessory Catalog*).
- Control board has temperature compensated circuits.
- A circuit on the control board regulates charging. "Sleep draw" is 40 mA; "active draw" is 2 to 5 A.
- Auto-memorization of digital transmitter code.
- GTO remote-mounted RF receiver tuned to 318 MHz.
- Limit controls are mechanical. Adjustable range of push-pull tube is 7<sup>1</sup>/<sub>2</sub>" to 11<sup>1</sup>/<sub>2</sub>". Opener length with push-pull tube fully retracted is 33<sup>3</sup>/<sub>4</sub>", mounting point to mounting point.
- Adjustable auto-close timer (OFF to 120 s), inertia, and obstruction sensitivity using three (3) potentiometers.
- Power terminal block accommodates a transformer and solar panels.
- DIP switches simplify setup of gate opener.
- Accessory terminal block fully compatible with push button controls, digital keypads, safety loops, etc.
- Control board allows connection of safety edge sensors and photoelectric sensors.
- Audio entrapment alarm sounds if unit encounters an obstruction twice while opening or closing.

### OPERATIONAL CAPACITY

- Depending upon the length of the gate leaves and the number of operational cycles\* per day, the Mighty Mule Gate Opener® can open single gates weighing up to 350 lb.—**if all installation procedures have been properly followed.**

Gate Length	16 ft.	135	120	105	NONE	NONE
	14 ft.	145	130	115	85	NONE
	12 ft.	155	140	125	95	60
	3.5-10 ft.	165	150	135	105	70
		50 lb.	100 lb.	150 lb.	250 lb.	350 lb.
		Gate Weight				

**NOTE: BALL BEARING HINGES SHOULD BE USED ON ALL GATES WEIGHING OVER 250 LB.**

To determine the number of cycles the gate opener will perform using solar panels, please see the specifications listed on *page 20* or call (800) 543-1236 or (850) 575-4144 for more information.

\* An operation cycle is one full opening and closing of the gate.

These specifications are subject to change without notice.



# Installation Overview

## Pull-to-Open Gates (Gate Opens into the Property)

The diagram shown below is an example of a pull-to-open installation on a chain link fence and single gate. Mounting the opener on a masonry column requires special procedures; see **Column Installation Information** on page 34 if you intend to mount the opener on a column. Furthermore, if you have a push-to-open gate, you will need to purchase a **push-to-open kit** (see *Accessory Catalog*) to properly configure your system. See **Push to Open Installation** on page 29 before proceeding.

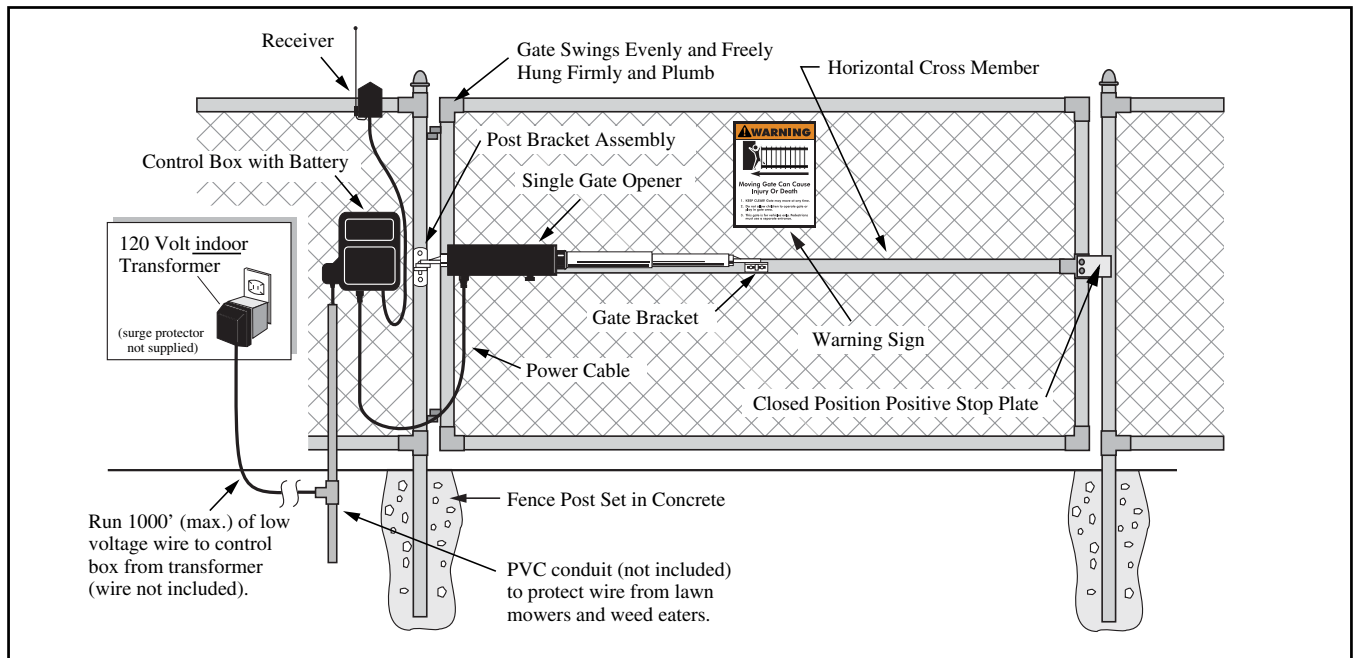

## Preparation of the Gate

### Step 1

The gate **must** be plumb, level, and swing freely on its hinges. Wheels must not be attached to the gate. The gate must move throughout its arc **without binding or dragging on the ground**. Note that gates over 250 lb. should have ball bearing hinges with grease fittings.

### Step 2

The fence post must be secured in the ground with concrete so it will not twist or flex when the opener is activated. Be sure to position the opener near the **centerline** of the gate to keep the gate from twisting and flexing. The addition of a **horizontal or vertical cross member** (if one is not already in place) to provide a stable area for mounting the gate bracket is also important.

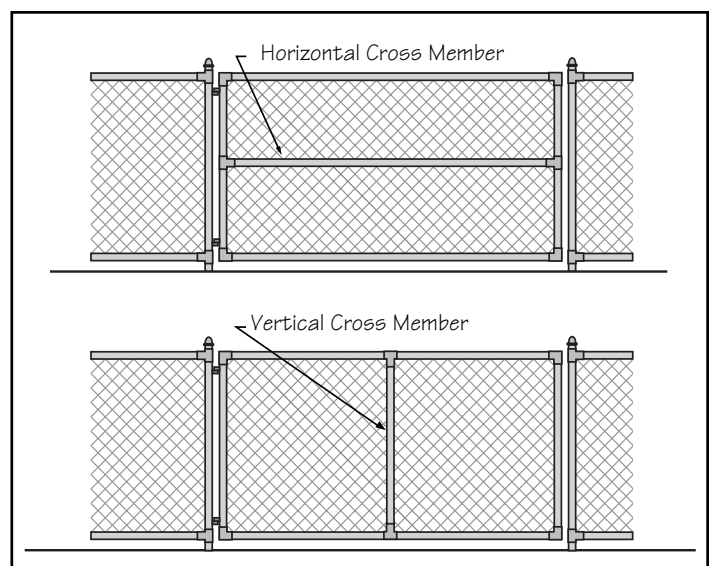

# Installation of Mounting Hardware

The position of the post bracket determines the leverage and efficiency of the opener. The post bracket position also sets the clearance between the opener and gate in the open and closed positions.

The curved design of the post bracket works well for installations on round and square fence posts. Because the post bracket carries the entire thrust of the active opener, **bolts that completely penetrate the fence post must be used.**

On wooden posts, place a metal plate or washer (*not supplied*) between the nuts and the fence post to prevent the thrust of the opener from pulling the bolts and washers out of the wood.

**NOTE:** A fence post smaller than 6" in diameter or 6" square should be made of metal instead of wood so that it will remain stable while the opener is moving the gate.

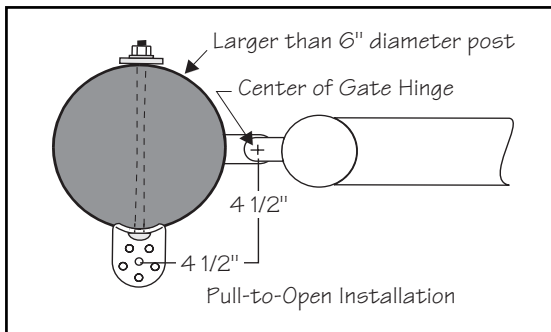
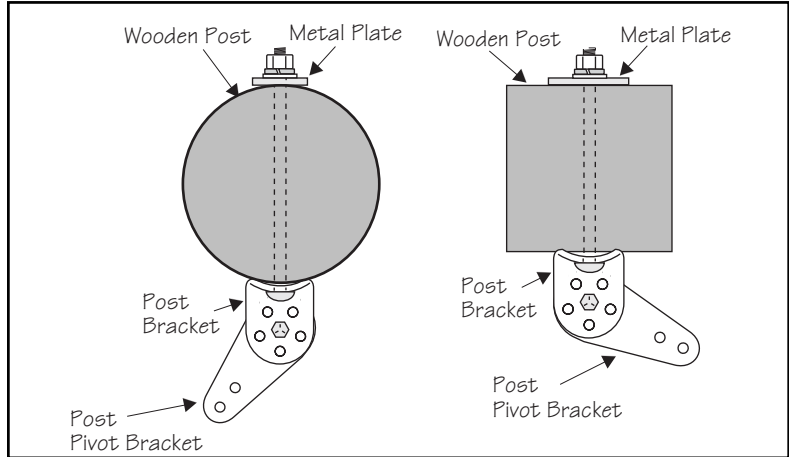

On round posts of 6" diameter or larger, the post pivot bracket may not be necessary for the installation. In this instance, the two post brackets are mounted by themselves.

## IMPORTANT:

We **strongly recommend** using steel pipe, wood or metal to reinforce thin walled tube gates or wood to reinforce panel gates as shown. These reinforcement methods will prevent damage to the opener and gate when the opener is installed.

Because the size tube gates vary, it is impossible to provide the appropriate reinforcement material for every application. If you are unable to locate suitable reinforcement materials, call GTO sales at 1-800-543-4283.

## Recommended Reinforcement Examples

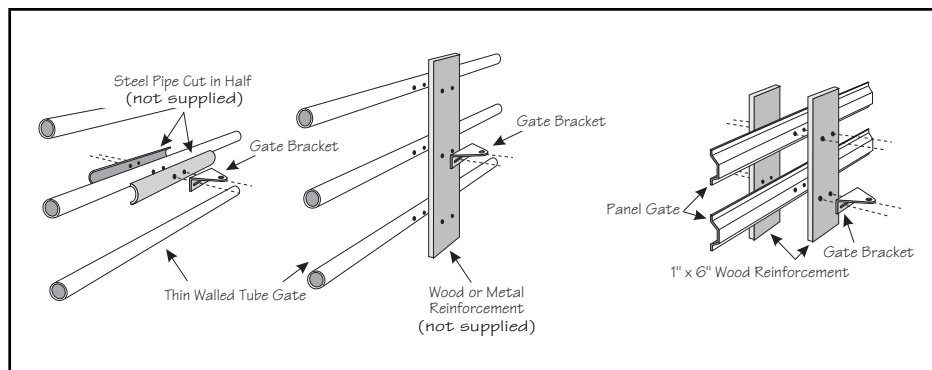



# Determining the Mounting Position of the Post Bracket Assembly and the Gate Bracket

## Step 3

Insert the 3/8" x 2" bolt through the center hole of the post brackets and post pivot bracket as shown. Fasten a 3/8" washer and nut on the end of the bolt. DO NOT *overtighten* the nut because the post pivot bracket will have to be adjusted later.

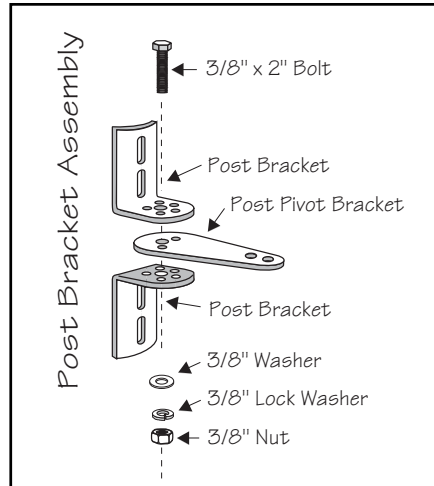

**NOTE:** The following steps are intended for **pull-to-open** gate installations. If you are mounting your opener on a push-to-open gate (e.g., a gate on a sloped driveway) you will need to purchase a **Push To Open bracket** (see *Accessory catalog*). Also, see **Push-to-Open Installation** beginning on page 29.

## Step 4

Attach post bracket assembly and gate bracket to the opener with the clevis pins and washers. Secure the clevis pins with hairpin clips.

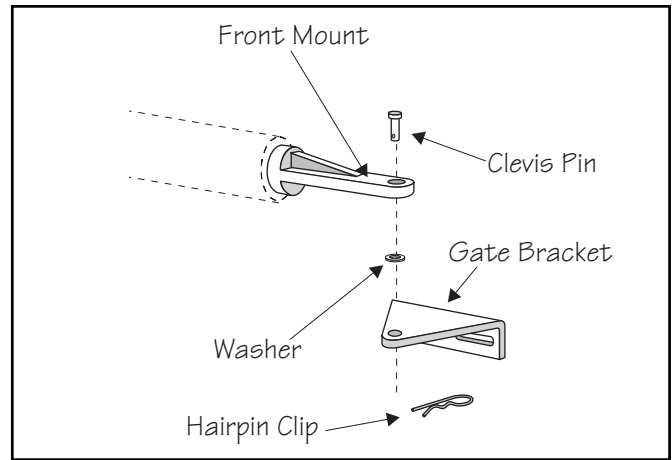
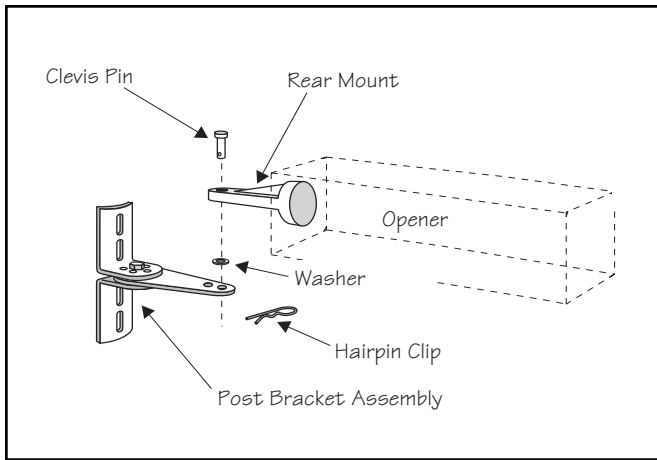

## Step 5

With the gate in the open position (80° to 110° from its closed position), adjust the post bracket assembly and gate bracket until the opener is level. While holding the opener level, use C-clamps to *temporarily* keep the post bracket assembly and gate bracket in their respective positions on the fence post and gate.

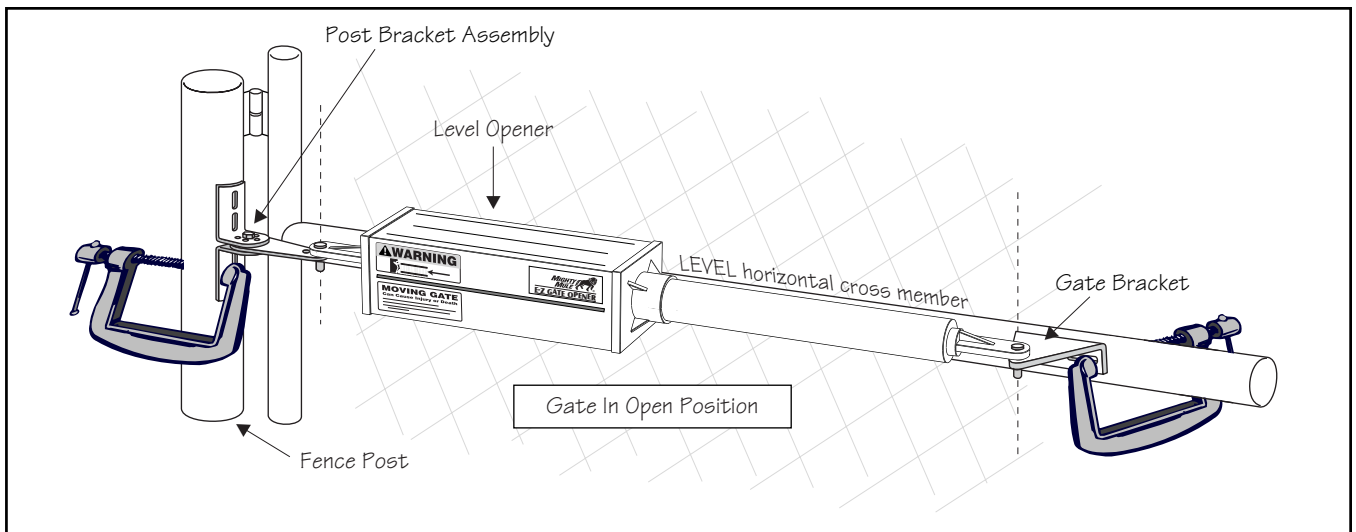

## Step 6

Study the 4 1/2" x 4 1/2" setback template (see insert) provided with this manual. Once you are familiar with its illustrations, **cut and save the template** from the insert. The template will determine the correct position of the post pivot bracket before mounting the opener on the fence post.

Remove hairpin, clevis pin, and washer from front mount and close the gate. Rest disconnected opener on cross member of gate. Stand inside property next to fence post and place one end of template over center of gate hinge. Place the other end of template over the post pivot bracket hole (either of the two mounting holes in post pivot bracket can be used) where the opener will be attached. Be sure to hold the template at a 90° angle between these two points and measure 4 1/2" back from the center of the gate hinge. You will need to rotate the post pivot bracket or the entire post bracket assembly to align it with the square angle of the template. **THE ANGLE BETWEEN THE GATE HINGE AND THE POST PIVOT BRACKET MUST MATCH THE ANGLE OF THE SETBACK TEMPLATE.**

**NOTE:** If you move the post pivot bracket, be sure one of the post bracket holes is aligned with the rest of the assembly (the center hole should already have a bolt through it).  
**Flipping the Post Pivot Bracket gives more position options.**

After verifying that you have complied with the 4 1/2" x 4 1/2" setback, insert the 5/16" x 1 3/4" bolt through the aligned holes of the post bracket and post pivot bracket (illustrated below) and fasten it with the 5/16" washer and nut.

**IMPORTANT:** If you loosened the clamp on the post bracket to achieve the 4 1/2" x 4 1/2" setback, tighten it in its new position and recheck the gate bracket with the gate in the open position (move the gate bracket and re-clamp it if necessary).

### Examples of a 4 1/2" x 4 1/2" Setback

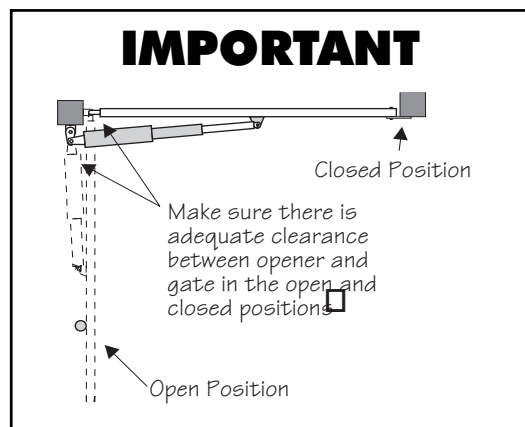
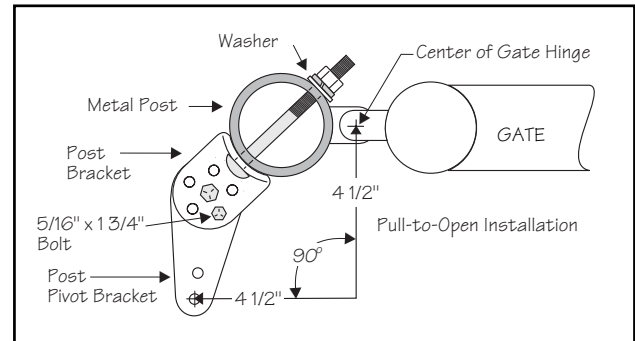
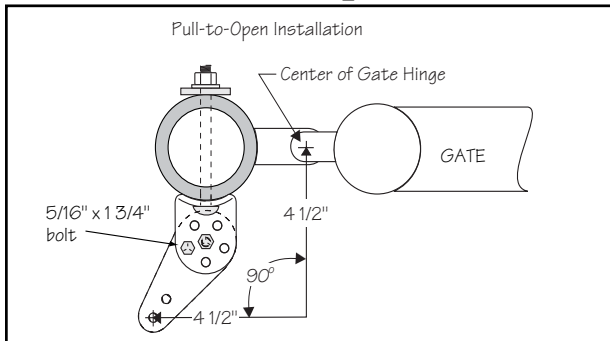

### Verify the Position of the Gate Bracket and Post Bracket Assembly:

With the gate in the open position, make sure the following conditions are met:

1. The opener is level.
2. The 4 1/2" x 4 1/2" setback measurement is correct (**Step 6**).
3. There is sufficient clearance between opener and gate in the open and closed positions.

# Installing the Post Bracket Assembly and Gate Bracket

## Step 7

Mark reference points for bolt holes on the fence post through middle of bracket slots. Marking reference points in this manner allows room for adjustment when mounting the post bracket assembly and gate bracket. After marking your reference points, remove the opener and brackets from the fence and gate.

## Step 8

Drill  $\frac{3}{8}$ " holes into fence post as marked.

## Step 9

Fasten post bracket assembly to the fence post using (4)  $\frac{3}{8}$ " x 8" bolts, washers, lock washers, and nuts (*provided*). Remove excess bolt length extending beyond the tightened nuts with a hacksaw or bolt cutters.

**NOTE:** In cases where the fence post has a diameter larger than 6", **threaded rods or carriage bolts longer than 8"** (*not supplied*) must be used.

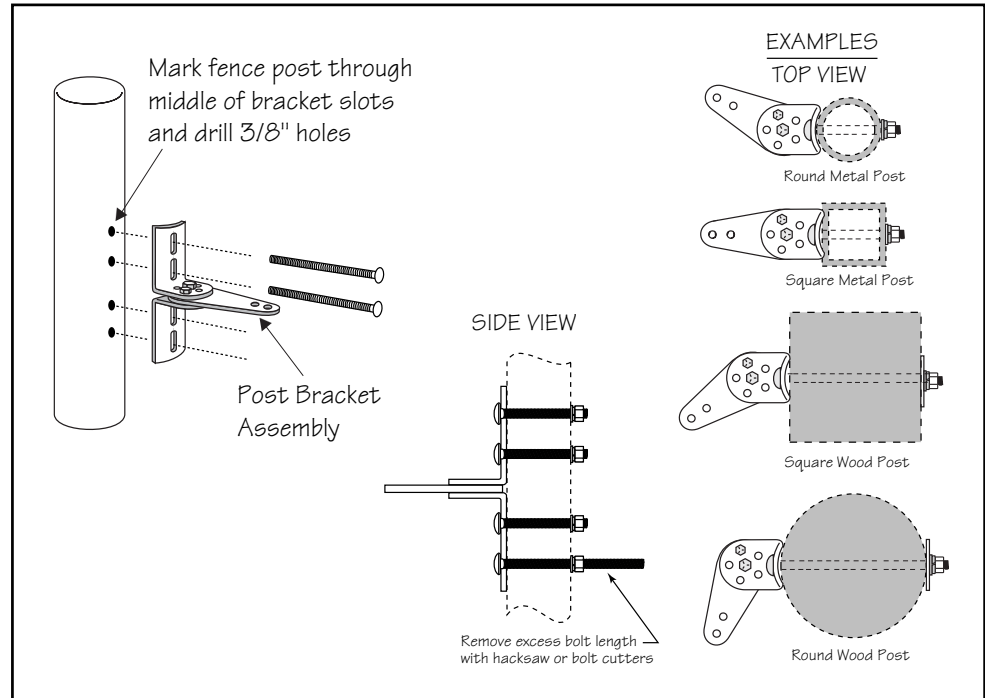

## Step 10

Mark reference points for bolt holes on the gate cross member through middle of gate bracket slots. Drill  $\frac{3}{8}$ " holes into the gate cross member as marked.

Mount gate bracket using (2)  $\frac{3}{8}$ " x 3" bolts, washers, lock washers, and nuts (*provided*). Cut off excess bolt length extending beyond the tightened nuts.

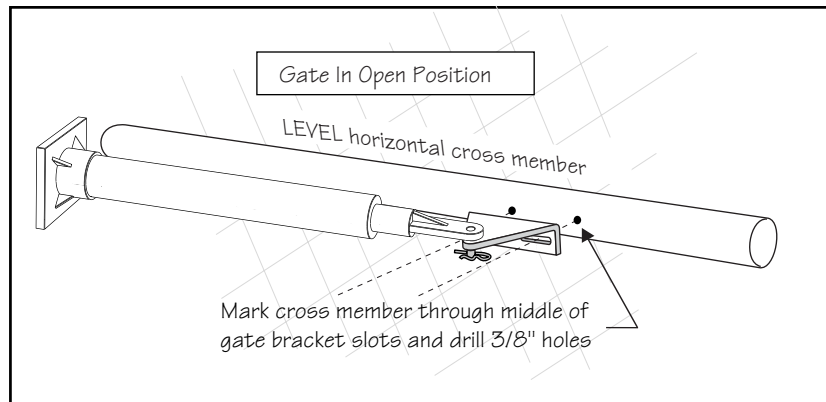

## Gate Bracket Mounting Examples

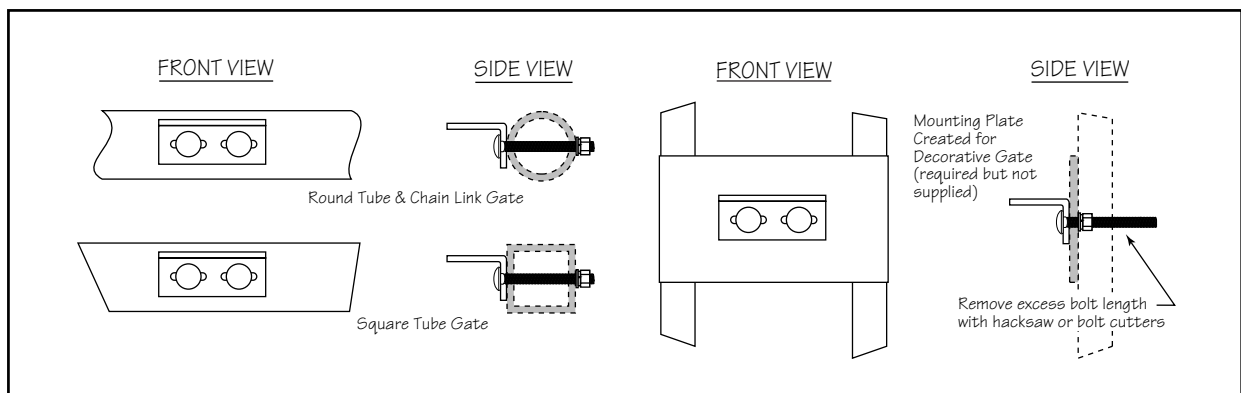

# Mounting the Opener

## Step 11

Attach the opener to the securely bolted post bracket assembly and gate bracket using clevis pins, washers, and hairpin clips, or optional Pin Locks (see *Accessory Catalog*). Verify that the opener is level and adjust the post bracket assembly if necessary.

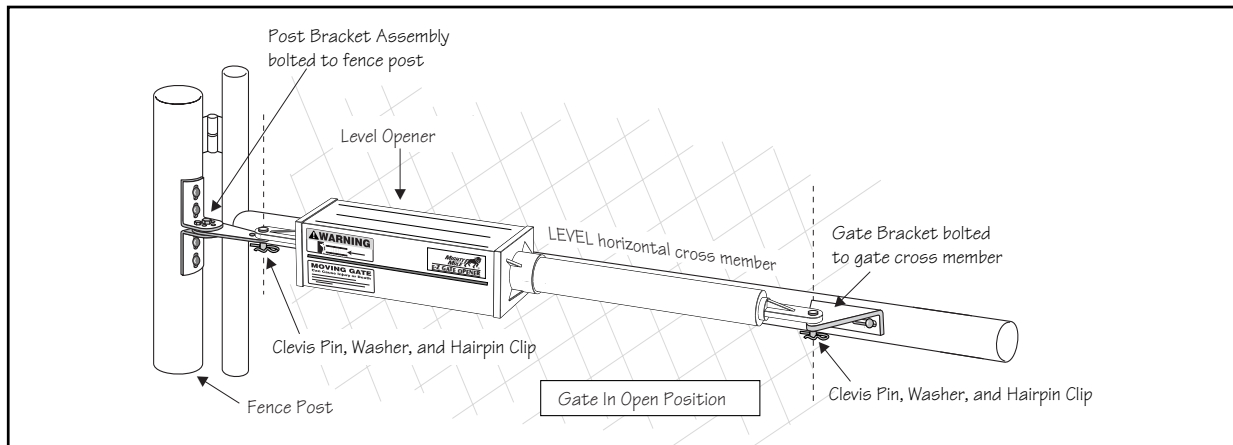

# Installation of the Positive Stops

The positive stops hold the gate firmly in the open and closed positions. The positive stops also form the boundaries of the gate operating arc and help stabilize the gate. Moreover, a stable gate maintains the long life of your automatic gate opener system. To further enhance the stability and security of your gate, install the optional **Mighty Mule Automatic Gate Lock®** (see *Accessory Catalog*).

## Step 12

With the gate at its *maximum open position*, measure the distance from the gate hinge to the end of the gate. At approximately  $\frac{2}{3}$  of this distance (using the hinge as your starting point), place a mark on the ground directly under the gate. Install the open position stop at this mark (see *illustration*). The open position stop post may be made of wood, metal, or concrete and should be firmly secured in the ground (we recommend setting it in concrete). When the open position stop post is in the ideal position, the gate will strike the post just as the opener motor shuts down.

## Step 13

Remove hairpin, clevis pin, and washer from front mount and close the gate (remember to support opener). Fasten the *closed position stop plate* to the end of the gate frame on the **gate centerline**, but **do not** tighten it completely. Slide the stop plate toward the fence post until they touch (see *illustration*). Once you have moved the stop plate to the correct position, tighten its hardware completely.

Use the appropriate hardware for your type of gate (use U-bolts if you have a tube or chain link gate; wood or lag screws for wood gates; etc.). This hardware is not provided.

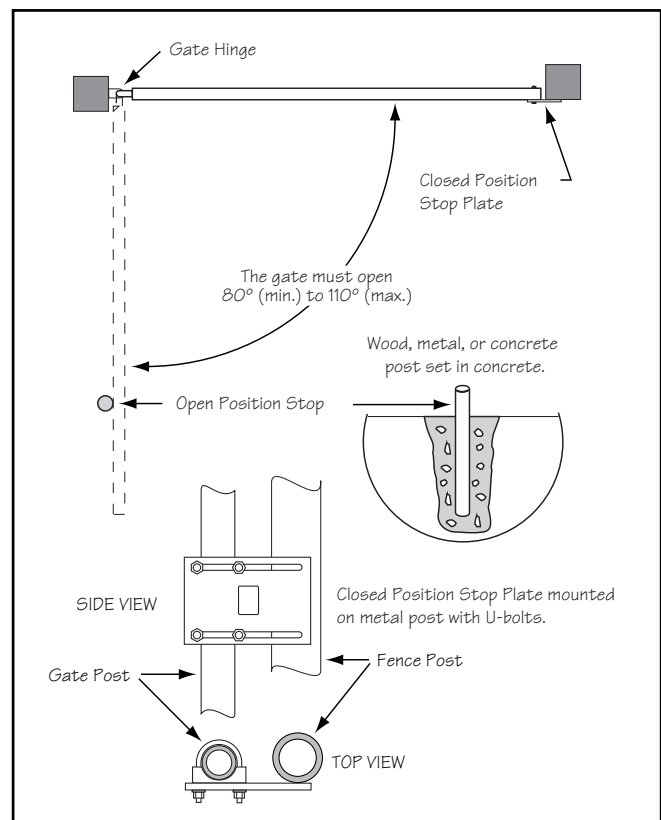

**At this stage of the installation, the opener should be installed on the gate and the open and closed position stops should be in place.**

#### Check List

- The gate is plumb, level, and swings smoothly on its hinges.
- After measuring with the 4 1/2" x 4 1/2" setback template, the post bracket assembly was bolted to the fence post.
- A plate or support was added for the gate bracket (if necessary).
- The opener is level and mounted on the centerline of the gate.

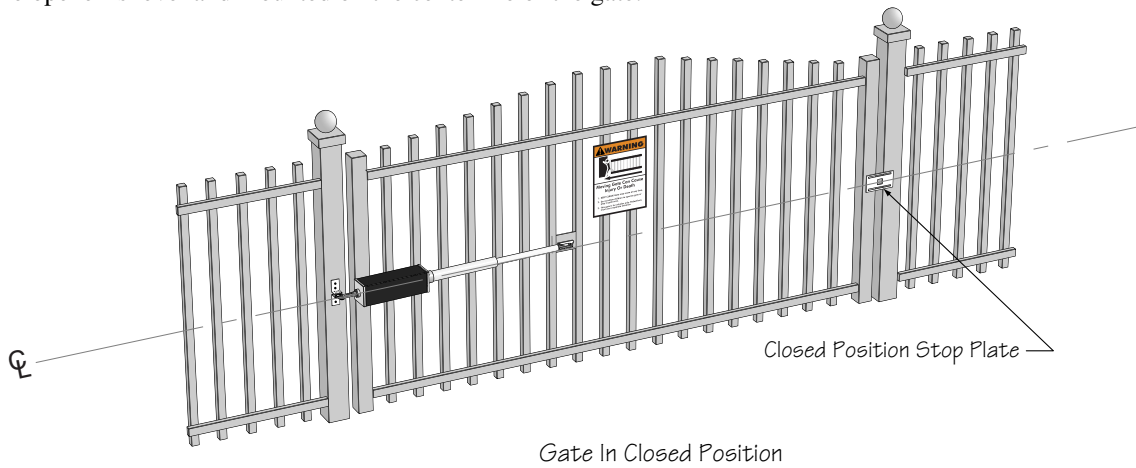

Open Position Stop Post  
(set in concrete) → 

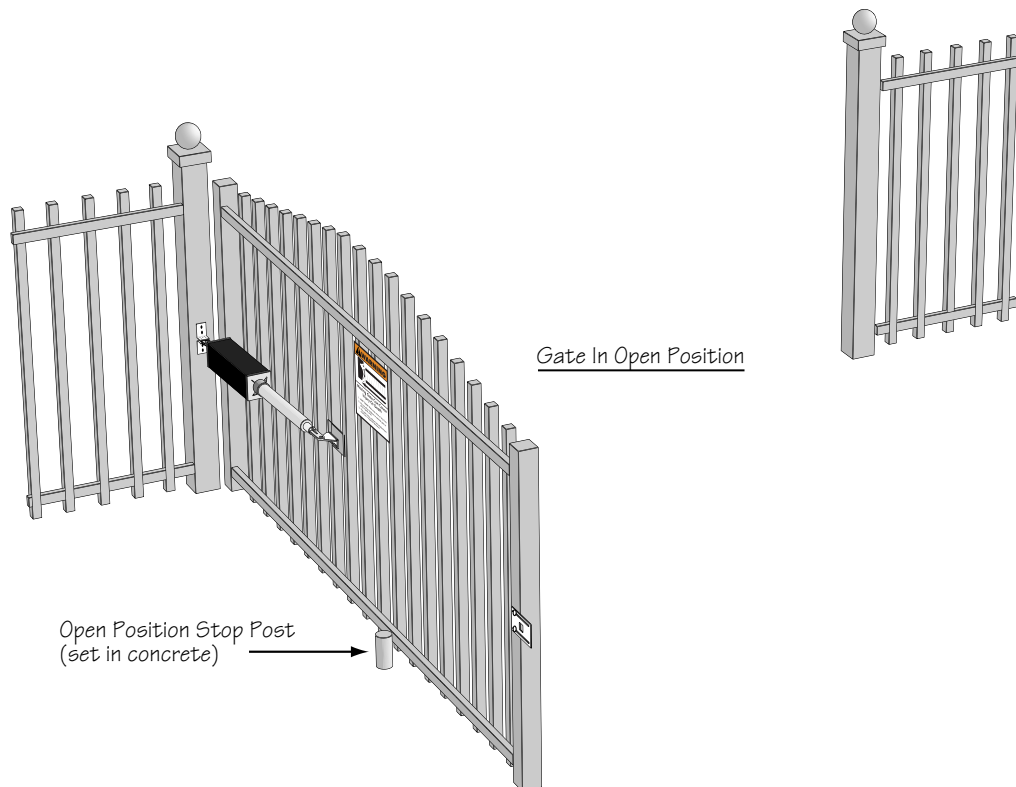

# Mounting the Control Box

## Step 14

Mount the control box using the nylon cable ties (*provided*) or another secure mounting method. The control box must be mounted at least **3 feet above the ground** to protect it from rain splash, snow, etc., and at least **3 feet from an ac power source** to prevent electrical interference.

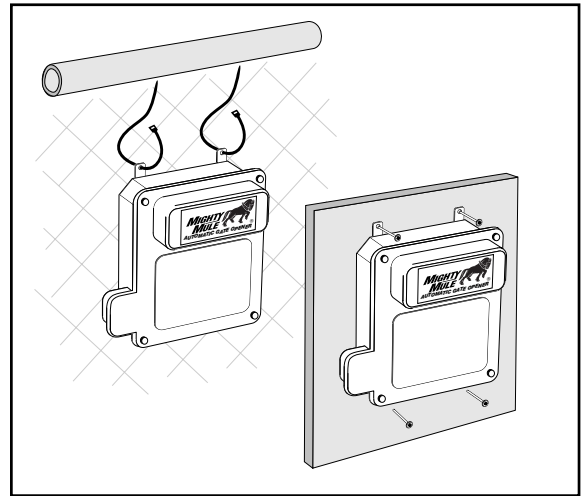
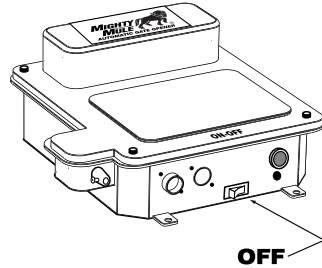

## Step 15

Make sure the control box power switch is in the **OFF** position. Unscrew and remove the control box cover and slide the battery into position with its terminals to the **left** (*see illustration*). Push battery down until it fits snugly in control box. Connect the **BLACK** battery wire to the **NEGATIVE (-)** battery terminal. Connect the **RED** battery wire to the **POSITIVE (+)** terminal. *Pay close attention to the color of the wires. If the wires are connected incorrectly, the control board will be damaged. NEVER insert the battery with the terminals to the right.*

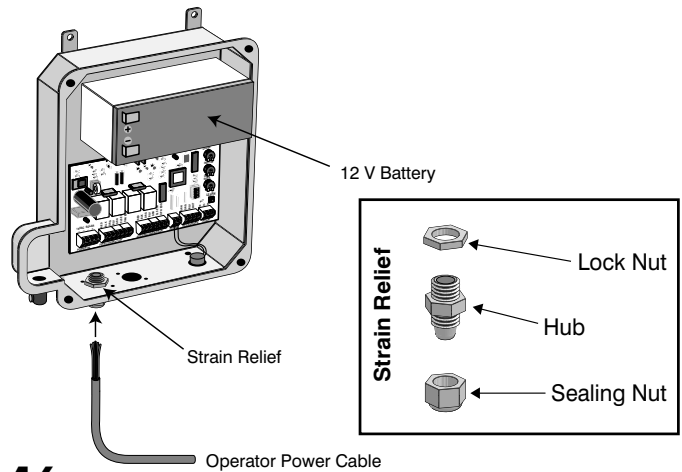
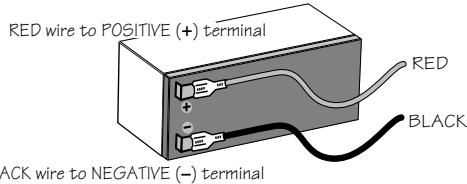

**HINT:** A dab of household petroleum jelly on the battery terminals will help prevent corrosion.

## Step 16

Strip approximately  $\frac{3}{16}$ " of insulation from each wire of the power cable. Twist each exposed wire tightly (there are five [5] wires inside the power cable sheath). Loosen sealing nut on strain relief hub at bottom of control box. Insert power cable into control box through strain relief. Thread approximately 4" of the power cable into the control box and retighten sealing nut until the power cable locks into place.

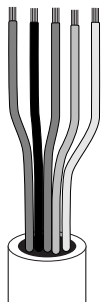
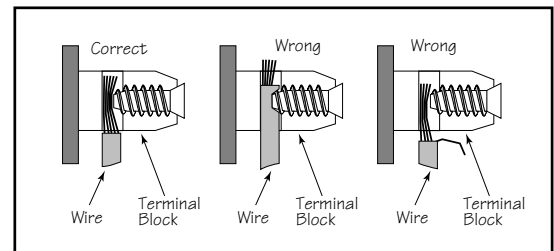
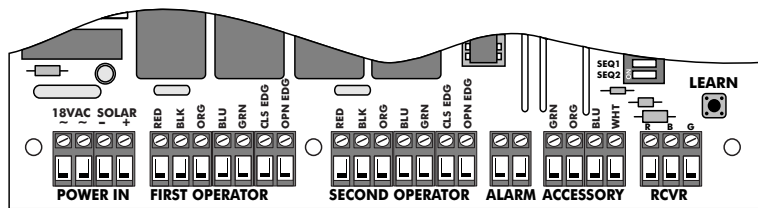

Power Cable for the Mighty Mule E-Z Gate Opener

Insert the stripped power cable wires into the appropriate terminals on the **FIRST OPERATOR** terminal block. The green wire should be inserted into the **GRN** terminal, the blue wire into **BLU**, the orange wire into **ORG**, black wire into **BLK**, and the red wire into the **RED** terminal.

Tighten the set screws against the end of the wires. A dab of petroleum jelly on each terminal will help prevent corrosion.

## Step 17

Carefully insert the power cable plug into the coupling at the rear of the opener. Turn the plug until it aligns with the pins in the coupling. Push the plug into the coupling until it stops. Finger tighten the sleeve nut to lock the plug in position.

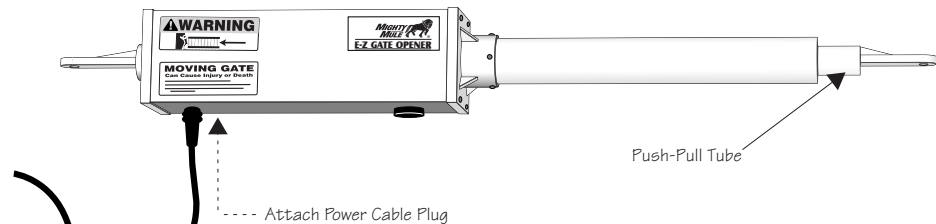

Replace the control box cover and fasten it with (4) screws. Turn the control box power switch ON.

The control board will energize in approximately 15 seconds.

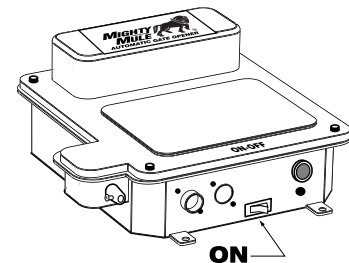

# Setting the Closed Position

## Step 18

Reattach the front mount of the opener arm to gate bracket using a clevis pin, washer, and hairpin clip. Press the transmitter button to activate the opener and determine the degree of gate closure. Initially, the push-pull tube will extend only 7" to 8" until the stroke adjustment knob is set (*see below right*). The maximum extension of the push-pull tube is 11 1/2".

## Step 19

To increase the degree of gate closure, loosen the **stroke adjustment knob** on the bottom of the opener housing and move it approximately 1/8" toward the gate bracket (*see Fig. A*). **Finger tighten the knob (DO NOT USE PLIERS OR OTHER TOOLS TO TIGHTEN KNOB)**. Press the transmitter button to check your adjustment. To decrease the degree of gate closure, move the stroke adjustment knob away from the gate bracket (*see Fig. B*).

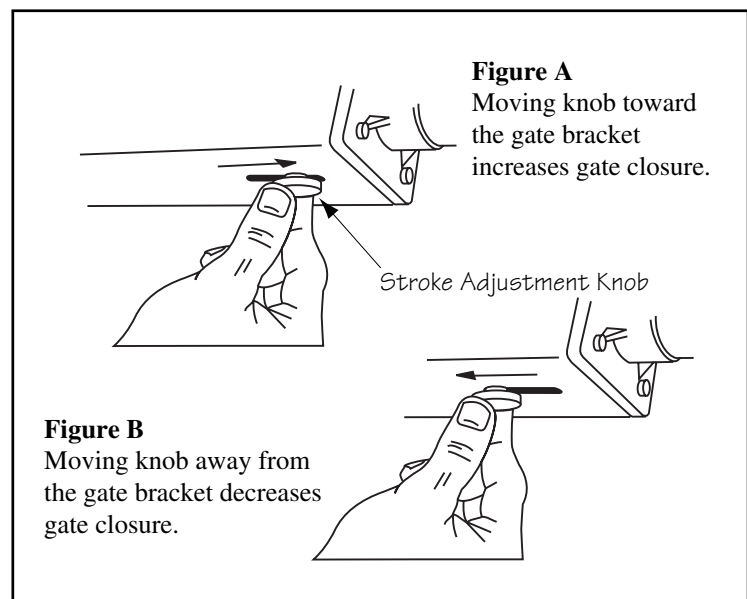

## Step 20

Repeat the procedure in Step 19 until the gate closes firmly as the opener motor shuts down. Each time you adjust the knob, finger tighten it before pressing the transmitter button to check your adjustment.

*If the push-pull tube has been extended too far* (i.e., if the knob is too close to the gate bracket), the gate will immediately reverse and open after closing. When the knob setting is correct, the gate will close firmly, but not sharply, against the positive stop plate. The motor will run for one-half second after the gate closes against the stop plate. If the motor continues to run for more than one second, the push-pull tube is overextended and further adjustment is necessary. If the motor strains too long against the stop plate, the fuse on the control board (above **FIRST OPERATOR** terminal) will be blown. This blade-style 15 ampere fuse (sold by most automotive supply stores) can be easily replaced.

**NEVER use a fuse rated higher than 15 amperes!**



# Powering the System

## Installation of the Transformer

### IMPORTANT:

- The transformer is designed and intended for indoor use. If the transformer can be plugged only into an outside electrical outlet, a weatherproof cover or housing (available at local electrical supply stores) **must** be used.
- All low voltage wire used with the Mighty Mule Gate Opener® must be 16 gauge dual conductor, multi-stranded, direct burial wire (see page 21 and the *Accessory Catalog*). **Do not run more than 1000 feet of wire.**
- If your gate is more than 1000 ft. from an ac power source, you will need to use at least one 5 watt Solar Panel to charge the battery (see *Accessory Catalog*). Refer to the **Solar Panels and Gate Activity** chart below.

## Solar Panels and Gate Activity

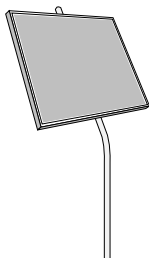

The table and map illustrate the maximum number of gate cycles to expect per day in a particular area when using one to three GTO 5 watt solar panels (see *Accessory Catalog*).

The figures shown are for winter (minimum sunlight) and do not account for the use of any accessory items. *Accessories connected to your system will draw additional power from the battery.*

**NOTE:** A maximum of three solar panels can be connected to the Mighty Mule Gate Opener®. Consult *Solar Panel Installation Instructions*.

Winter Ratings	Zone 1	Zone 2	Zone 3
12 volt single gate (one 5 W panel)	4	8	13
12 volt single gate (two 5 W panels)	8	16	26
12 volt single gate (three 5 W panels)	11	20	30

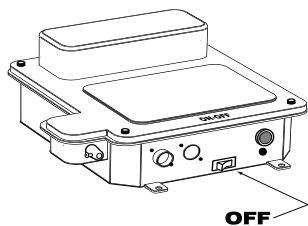

### Step 21

Make sure the power switch is **OFF** before proceeding to the next step.

### Step 22

Select the electrical outlet into which you will plug the transformer. Measure the distance from this outlet to the control box following the path where the wire will be laid. After you have measured how much wire is needed, cut the wire to the appropriate length.



## **⚠ IMPORTANT INFORMATION ABOUT LOW VOLTAGE WIRE ⚠**

The only wire acceptable for use with GTO products is 16 gauge multi-stranded, low voltage, PVC sheathed wire. This particular gauge enables the transformer to provide an adequate charge through the control board to the battery at distances up to 1000 ft.

**DO NOT** use telephone wire or solid core wire. Unlike multi-stranded wire, these types of wire are inadequate for use with your gate opener system. Telephone wire and solid core wire do not deliver enough voltage for your gate opener to function and will cause the system to go into a condition known as "low voltage lockout."

Never splice wires together. Splicing permits corrosion and seriously degrades the wire's ability to carry an adequate current.

### **Step 23**

Lay the measured length of low voltage wire in a trench following a path from the selected electrical outlet to the control box. Wires coming up from the ground should be run through PVC conduit to protect them from lawn mower blades, weed eaters, and grazing animals. Be sure to bury the wire laid in the trench.

### **Step 24**

Feed the low voltage wires upward through the strain relief opening on the lower left of the control box. Pull 6" to 8" of wire into the control box and tighten the strain relief screw to secure the wires.

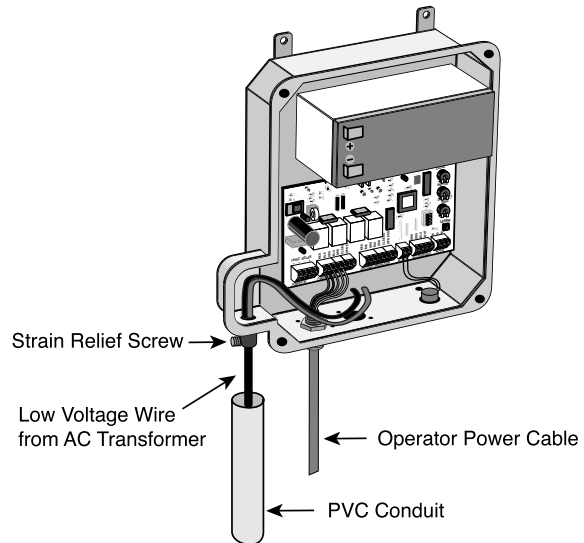

**⚠ WARNING! DO NOT PLUG THE TRANSFORMER INTO AN OUTLET DURING THIS STEP! THE TRANSFORMER MUST ONLY BE PLUGGED INTO AN OUTLET DURING STEP 27!**

### **Step 25:**

Strip  $\frac{3}{16}$ " off the ends of the low voltage wire and twist tightly. Attach these ends to the 18VAC terminals located on the **POWER IN** terminal block (see illustration at right). **Be certain not to let the exposed wires touch each other!**

Insert one transformer wire into an 18VAC terminal. Insert the other transformer wire into the remaining 18VAC terminal. The transformer wires can be connected to the 18VAC terminals regardless of color.

Tighten set screws against exposed end of wires. A dab of household petroleum jelly on each terminal will help prevent corrosion.

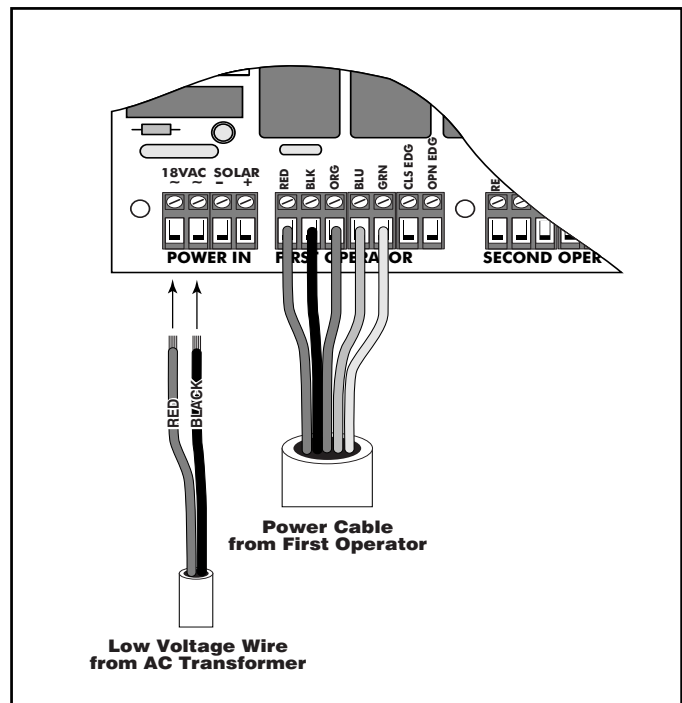

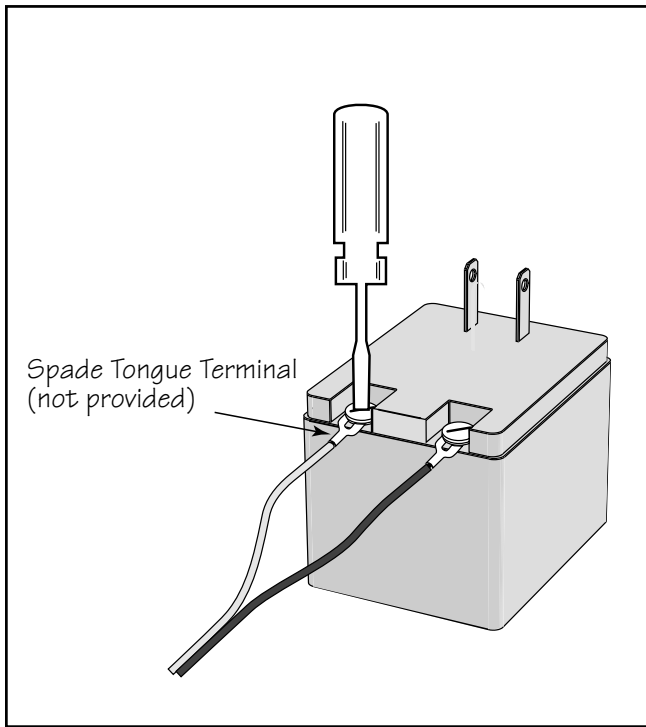

## Step 26

Strip  $\frac{1}{2}$ " of insulation from the ends of the low voltage wire. Attach these stripped ends to the transformer terminals; **red wire to RED**, **black wire to BLK**.

A dab of household petroleum jelly on each terminal will help prevent corrosion.

We suggest crimping a spade tongue terminal (*not provided*) to the end of each wire before attaching it to the transformer.

**Make sure the exposed wires do not touch each other!**

## Step 27

Plug the transformer into the electrical outlet. (Use of a surge protector with the transformer is strongly recommended.)

**HINT:** Keep a few mothballs in the control box to discourage insects from entering it and damaging the control board.

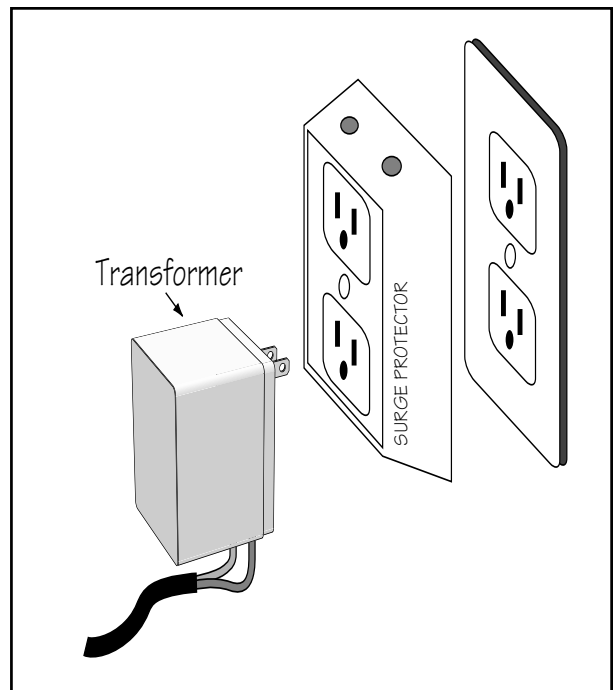

## Step 28

Turn control box **ON**.

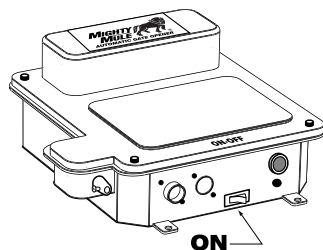

# CONTROL BOARD SETTINGS

## DIP switches

The four DIP switches on the control board match the opener with the type of gate on which it is installed. For example, gates may pull-to-open or push-to-open. Prior to packaging, the Mighty Mule Gate Opener® control board was configured for *single swing gates that pull-to-open* (open into the property). If your gate type matches this configuration, you **DO NOT** need to adjust the DIP switches; proceed to the **Potentiometers** section on the next page.

**NOTE:** To change the DIP switch settings, you must turn the control box power switch OFF; move the switch; then turn the power back ON. Use a small screwdriver to move the switches.

**PULL/PUSH:** Set to **PULL** for swing gates that pull-to-open [factory setting]; **PUSH** for swing gates that push-to-open (see **Push to Open Installation** on pages 29-30).

**NOTE:** The direction a gate opens is determined by standing inside the property and facing toward the gate.

**SNGL/DUAL:** Set to **SNGL** for a single gate leaf [factory setting]; **DUAL** not applicable.

**SEQ1:** Not applicable (the factory setting is OFF).

**SEQ2:** Not applicable (the factory setting is OFF).

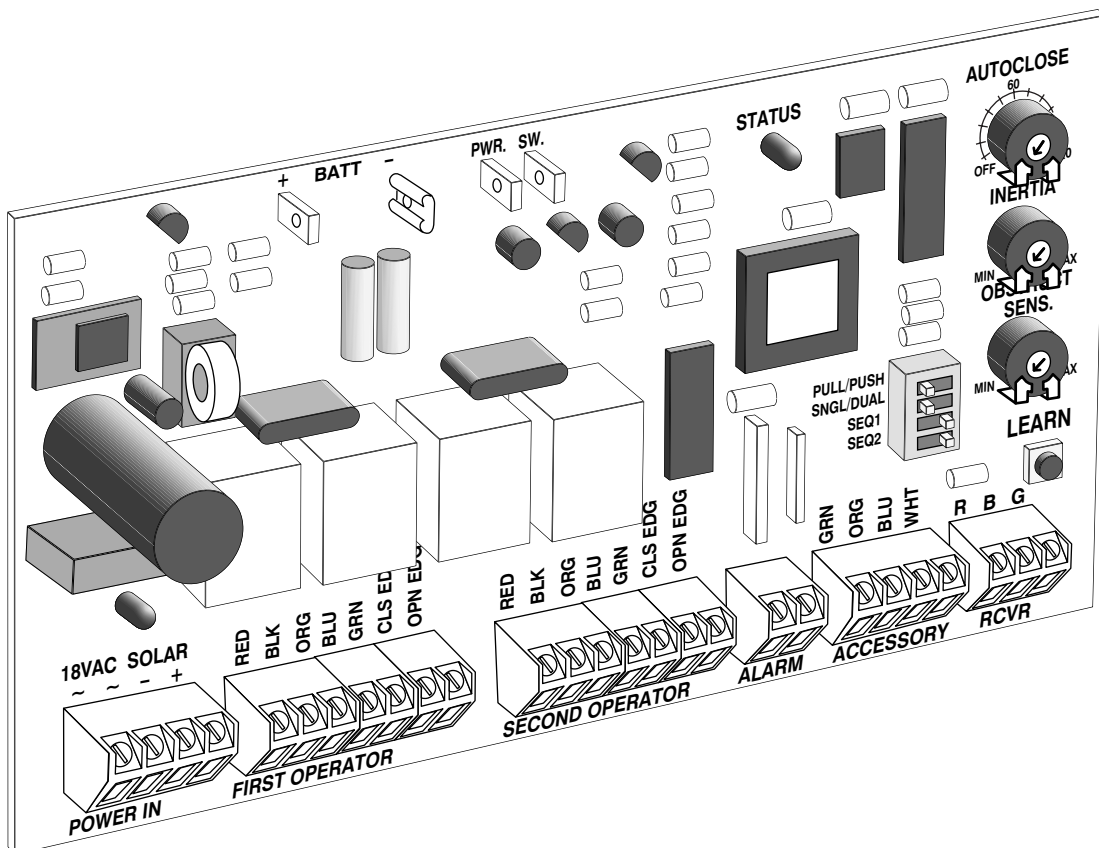
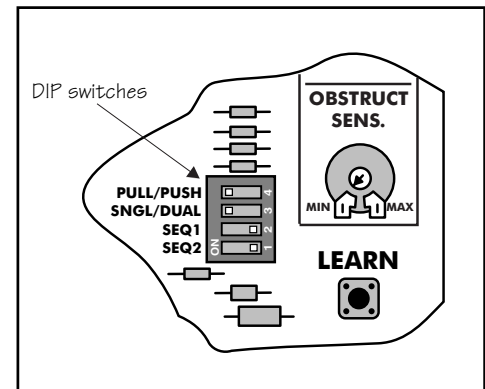

# Potentiometers

The three (3) potentiometers on the control board operate like a volume control on a radio. They control the auto close timer, inertia, and obstruction sensitivity of the opener. Use a small slotted screwdriver to turn the arrow in the center of the potentiometer. Clockwise rotation increases the setting (**MAX**). Counterclockwise rotation decreases the setting (**MIN**).

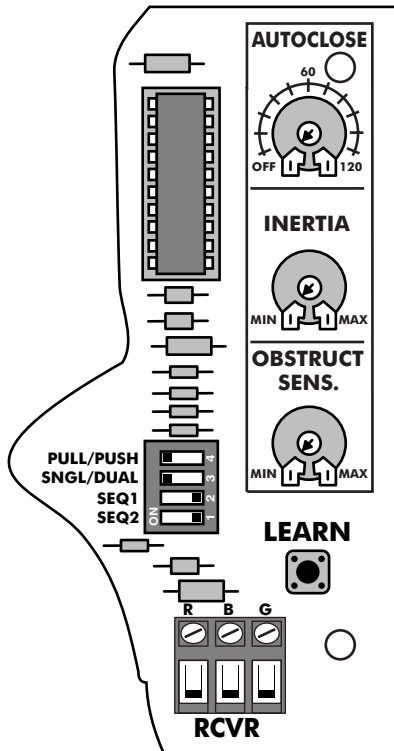

**AUTO CLOSE** (auto close timer): Determines how long the gate will remain open before it automatically closes. The limits are **OFF** to 120 seconds. The factory setting is **OFF**.

**INERTIA**: Fine tunes obstruction sensitivity in the opening and closing modes. **INERTIA** allows the opener to attempt to push an obstruction clear of the gate path. When **INERTIA** is set to **MIN** the opener will obstruct *quickly* (i.e., will attempt to push against an obstruction briefly); when set to **MAX**, the opener will obstruct *slowly* (i.e., will push against an obstruction for a longer period). The factory setting is **MIN**.

**OBSTRUCT SENS.** (obstruction sensitivity): Determines the amount of *force exerted by the gate* on an obstruction before the opener stops and reverses. The gate will exert *minimum force* before obstructing when set to **MIN**. When set to **MAX**, the opener will exert *maximum force* before obstructing (i.e., the opener will require greater resistance before stopping and reversing.). The factory setting is **MIN**.

## READ WARNING BELOW!

**NOTE:** Heavy gates and gates with high wind resistance *may* require the **OBSTRUCT SENS.** potentiometer to be set closer to **MAX** to prevent the opener from obstructing. Keep in mind, however, that while you must determine the best setting for *smooth* gate operation, you must **ALSO** determine the lowest possible setting for *safe* gate operation.

**ALWAYS KEEP SAFETY AT THE TOP OF YOUR LIST WHEN ADJUSTING OR SERVICING YOUR AUTOMATIC GATE OPENER!**

## ⚠ WARNING! ⚠

All three potentiometers were set to minimum at the factory. The **OBSTRUCT SENS.** potentiometer **MUST** be adjusted above the factory setting for your Mighty Mule Gate Opener® to function properly. If the potentiometer is left at **MIN**, your gate opener may "obstruct" (i.e., stop and reverse) as soon as it is activated.

**BE SURE TO PROPERLY RETEST THE GATE OPENER AFTER MAKING ANY ADJUSTMENTS; FAILURE TO DO SO MAY RESULT IN SERIOUS INJURY OR DEATH!**

# Setting Your Personal Transmitter Code



All GTO transmitters are set to a standard code at the factory and are ready to operate your Mighty Mule Gate Opener®. For your safety and security, however, we **strongly recommend** that you replace the factory setting with your own personal code. Follow the directions below:

## 1. Remove the Transmitter Cover

Grasp the sides of the access cover and slide it away from the transmitter button (see illustration). When the access cover is removed, the battery and the DIP switches will be exposed. To set a new code, use a small screwdriver to move the switches.

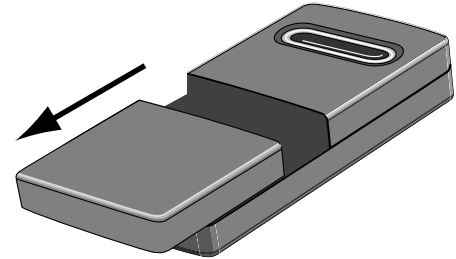

## 2. Set the transmitter DIP Switches

There are nine (9) transmitter DIP switches; each can be placed in three different positions (+, 0, -). **DO NOT** set all the switches in the same position, such as all +, all 0, or all -. Once the DIP switches have been set to a personal code, replace and close the access cover.

**WARNING:** No other adjustments should be made inside the transmitter.

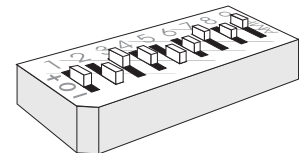

### 3. "Teach" the New Code to Control Board Memory

- A. Turn control box power switch **OFF**.
- B. Unscrew and remove the control box cover.
- C. Press and hold the **LEARN** button on the control board, and turn the power switch **ON**. Release **LEARN** button. Wait 15 seconds for the receiver to charge.
- D. Press and hold transmitter button until the red **STATUS** LED comes **ON**.
- E. Release transmitter button. The new code is stored in control board memory.

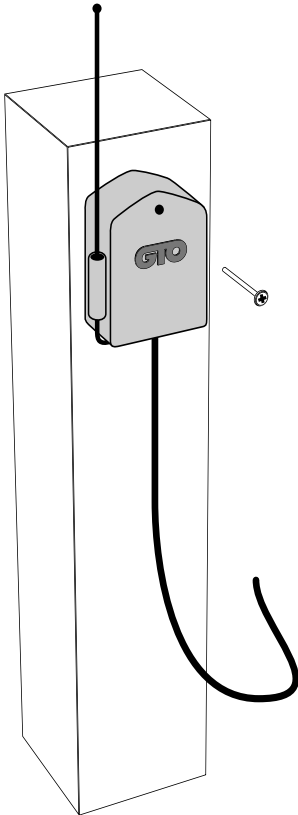
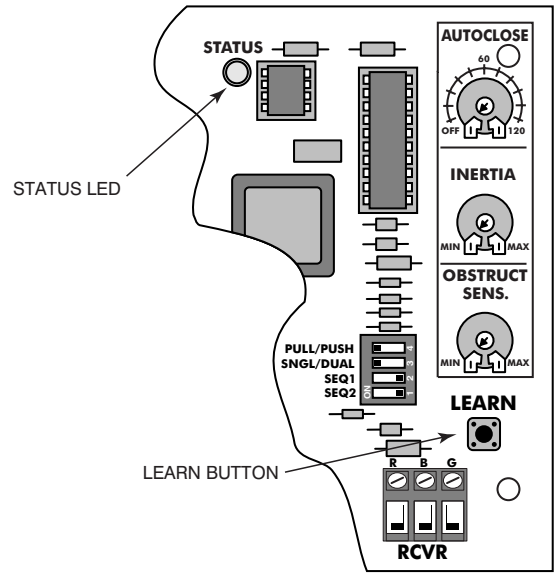

## Mounting the Receiver

Use the transmitter to check the range of the receiver *before permanently mounting it*.

Consider the following when mounting the receiver:

- Standard receiver cable length is 10 feet (receivers with a longer cable are available as special order items; *call the GTO Sales Department*). **NEVER** splice receiver cable!
- **Run the cable through PVC conduit to protect it from damage.**
- **DO NOT** run cable through metal conduit because the receiver signal range will be decreased.
- **DO NOT** run cable in conduit containing ac wiring.
- **DO NOT** mount receiver on a metal fence or post; doing so will decrease signal range.
- The receiver range can vary from 50 to 100 feet depending upon weather, topography, and external interference.

#### FCC Regulation

This device complies with FCC rules Part 15. Operation is subject to the following conditions:

1. This device may not cause harmful interference.
2. This device must accept an interference that may cause undesired operation.

Transmitter distance may vary due to circumstances beyond our control. **NOTE: The manufacturer is not responsible for any radio or TV interference caused by unauthorized modifications to this equipment. Such modifications could void the user's authority to operate the equipment.**

# Connecting Additional Safety Devices

Although GTO strongly recommends the use of additional safety devices, we do not endorse any specific brand names. Only use products that are certified and listed to be in compliance with UL (United Laboratories) and national and regional safety codes.

Call GTO Sales at 1-800-543-4283 for information on compatible products for your specific application.

The Mighty Mule E-Z Gate Opener is equipped with built-in obstruction sensitivity. The opener is designed to stop and reverse within 2 seconds when it comes in contact with an obstruction. However, obstruction sensitivity, even when properly adjusted, *may not be sensitive enough to prevent bodily injury in some circumstances*. To augment your protection against entrapment, GTO *suggests* using safety edge sensors or photoelectric sensors. When installed, safety edge sensors (or photoelectric sensors) must be mounted in compliance with UL 325, Underwriters Laboratories safety standard for gate openers. Review page 5 for information about mounting requirements for safety edges ("contact sensors") and photoelectric sensors ("non-contact sensors").

Refer to the sensor manufacturer's instructions for information about installing these devices on a vehicular gate.

**⚠** Make sure the control box power switch is OFF before connecting safety device wiring to the terminal blocks.

Insert the safety device wires into the **CLS EDG** terminal on the **FIRST OPERATOR** terminal block for the gate closing mode. Connect the safety device ground wire to the **GRN** terminal. Connect the safety device wires for the gate opening mode to the **OPN EDG** terminal in the same manner.

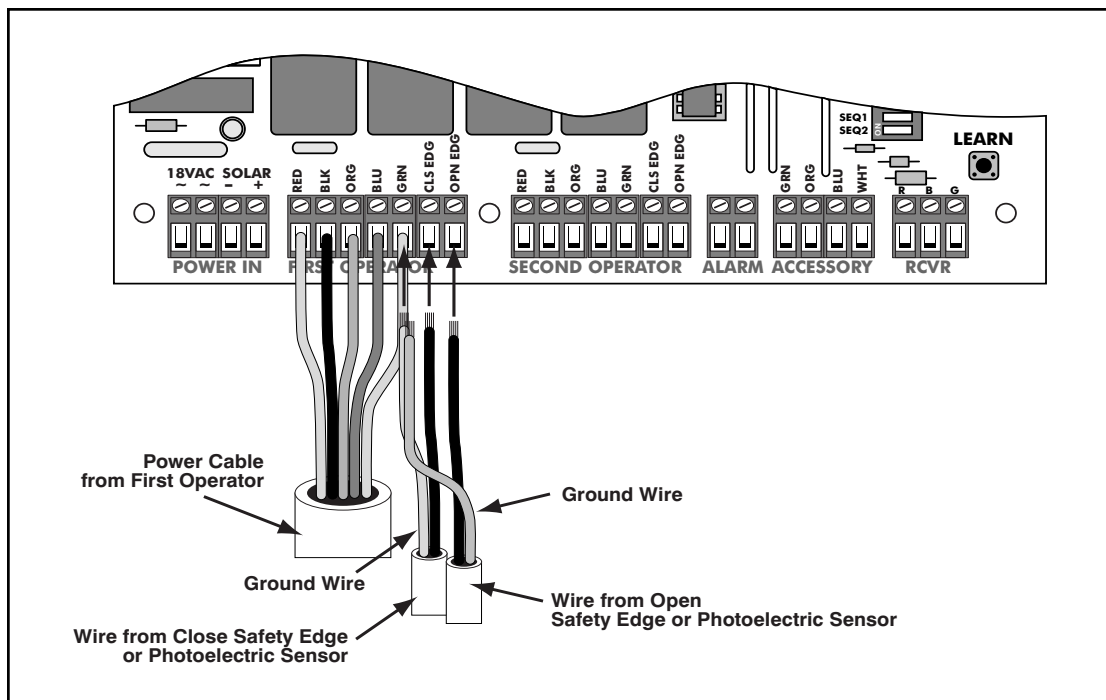

**PLEASE NOTE:** Safety edge sensors and photoelectric sensors are neither *included with* nor *required for* the Mighty Mule E-Z Gate Opener.

# Connecting Accessories

**⚠** Make sure the control box power switch is OFF before connecting accessories.

The **ACCESSORY** terminal block is the connection point for accessories such as keypads, push buttons, safety loops, intercoms, etc. The **ACCESSORY** terminal marked **GRN** (green) is the common ground for all accessories. **GRN** is paired with the terminals shown below when connecting accessories to the control board.

**IMPORTANT:** Make sure to twist the exposed wires tightly and insert them into the terminals without loose strands. Tighten the set screws against the exposed end of the wires. A dab of household petroleum jelly in each terminal will help prevent corrosion.

## WHT (white) used with GRN (green):

Functions as a normally open contact. This is the most frequently used pairing for a doorbell button, keypad, or key switch.

- First contact will start the gate.
- Second contact will stop the gate.
- Third contact will reverse the gate.

**NOTE:** *Never use a lighted doorbell button!*  
The battery will discharge and the gate opener will fail to operate.

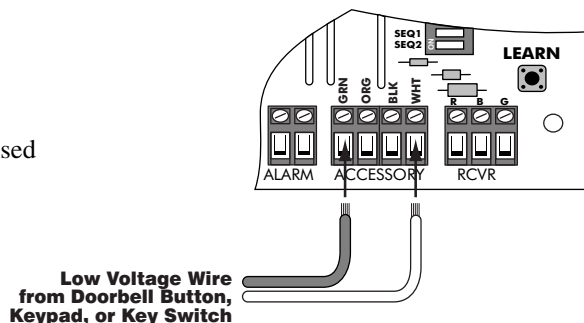

## BLU (blue) used with GRN (green):

Functions as a normally open contact. This pairing is typically used for free entry and free exit devices.

- First contact will open the gate.

**NOTE:** If the gate is in the open position and begins to close, the activation of the accessory device will reopen the gate. In communities where the use of an emergency entry device is mandatory, it should be connected to these terminals.

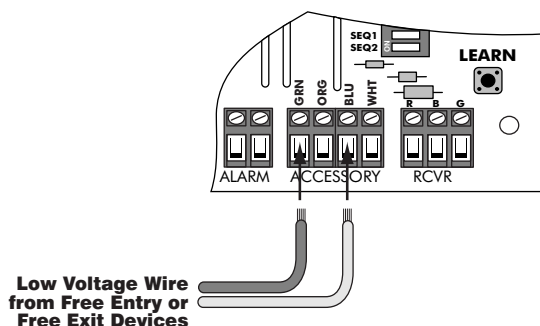

## ORG (orange) used with GRN (green):

Functions as a normally open contact. This pairing is frequently used for safety loops.

This connection will not open your gate. The safety loop will activate *only while the gate is in use*. When using this combination, the gate will remain open or reopen if it is closing.

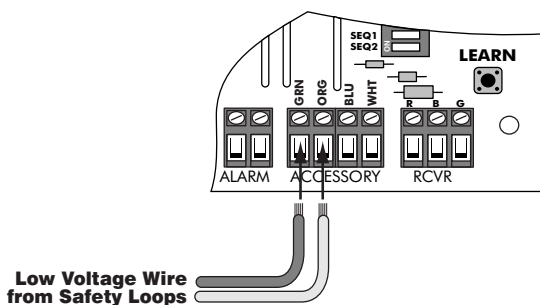



# Push to Open Installation

## Determining The Mounting Position of The Post Bracket Assembly

**⚠** Swinging gates shall not open into public access areas!

A "Push-to-Open" gate opens *out* from the property. A **Push-to-Open Bracket** is required for this type of installation (see *Accessory Catalog*). If you have a pull-to-open gate (gate opens *into* the property), return to page 13; step 3.

The opener is installed while the gate is in the **closed** position.

### Step PTO-1:

With the gate **closed**, adjust the post bracket assembly and the gate bracket until the opener is level. While holding the opener level, use C-clamps to temporarily keep the post bracket assembly and gate bracket in their respective positions on the fence post and gate.

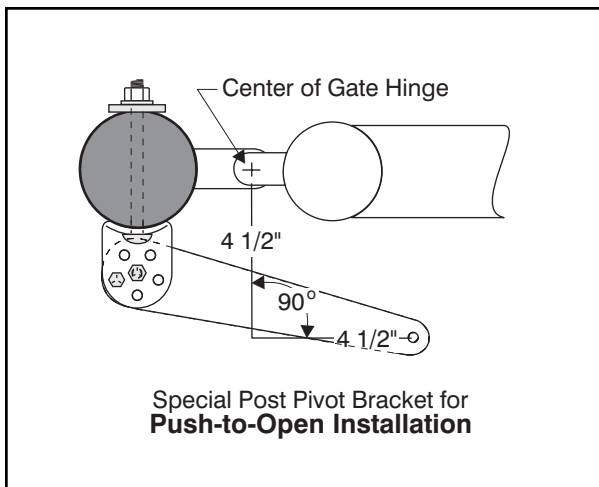
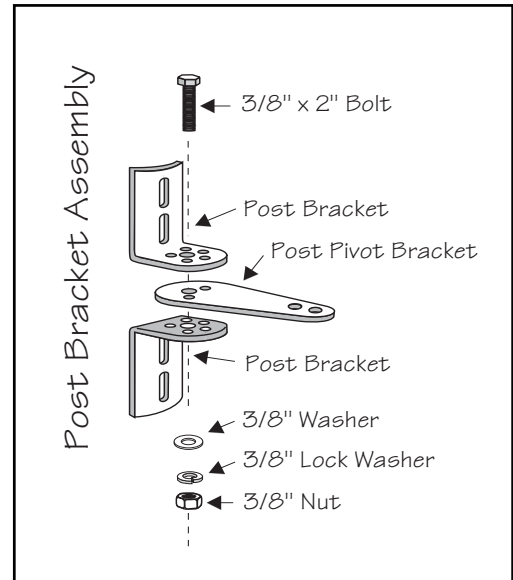

### Step PTO-2:

While gate is closed, stand inside the property next to the fence post. Using the **setback template** (*insert*) measure 4 1/2" back from center of gate hinge, then make a 90° angle toward the gate and measure 4 1/2". This is the point where either one of the holes at the end of the post pivot bracket should be. You will need to rotate the post pivot bracket or the entire post bracket assembly to align it with the square angle of the template.

**NOTE:** If you move the post pivot bracket, be sure that one of the post bracket holes is aligned with the rest of the assembly. **Flipping the Post Pivot Bracket gives more position options.**

After verifying that you have complied with the 4 1/2" x 4 1/2" setback, insert the 5/16" x 1 3/4" bolt through the aligned holes of the post bracket and post pivot bracket and fasten it with the 5/16" washer and nut.

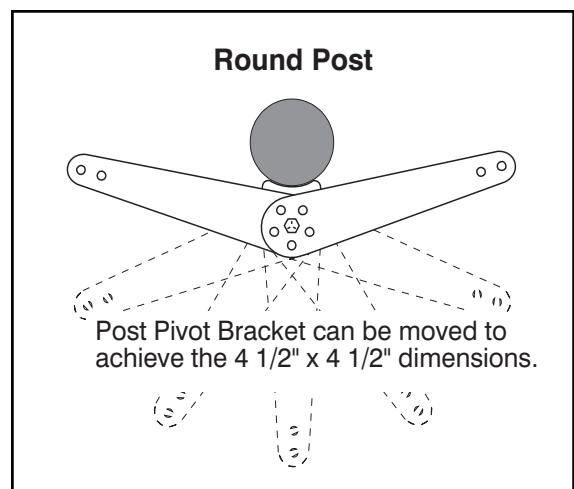
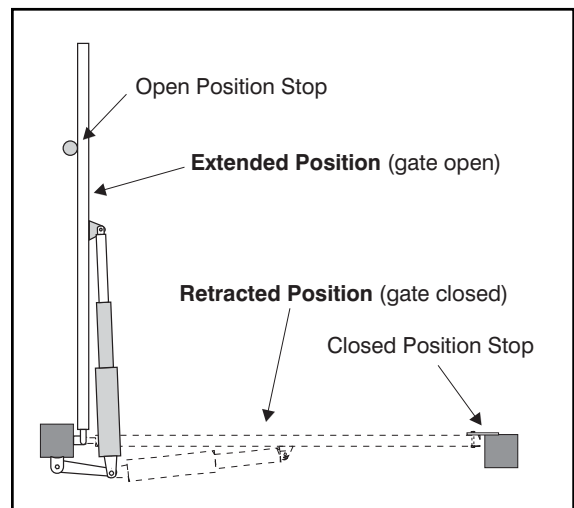

### Step PTO-3:

With the gate in the **fully closed position** and the opener retracted, swing the opener to the gate. Mark reference points for bolt holes on gate cross member through middle of gate bracket slots. The opener must be level. (Some vertical adjustment is possible by sliding the post bracket assembly up and down.) Drill  $\frac{3}{8}$ " holes into the gate cross member as marked. Fasten gate bracket to cross member using (2)  $\frac{3}{8}$ " x 3" bolts, washers, lock washers, and nuts. Attach the opener to the post bracket assembly and gate bracket using clevis pins, washers, and hairpins clips.

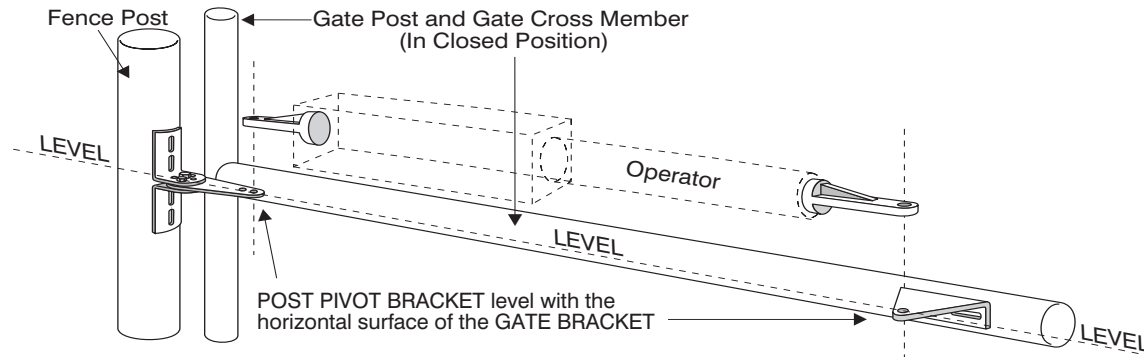

### Step PTO-4:

Make sure the control box power switch is **OFF**. Use a small screwdriver to move the **PULL / PUSH** DIP switch from the factory setting to **PUSH**. Replace control box cover. Turn power switch **ON**. The control board is now configured to *push* the gate open.

### Step PTO-5:

Press the transmitter to activate the opener and determine the degree of gate opening. Initially, the push-pull tube will extend only 7 1/2" until it is adjusted (see below right). The maximum extension of opener is 11 1/2".

### Step PTO-6:

To *increase* the degree of gate opening, loosen the **stroke adjustment knob** on the bottom of the opener housing and move it about 1/8" toward the gate bracket (see Fig. A). **Finger tighten the knob—DO NOT USE PLIERS OR OTHER TOOLS TO TIGHTEN KNOB.** Press the transmitter to check your adjustment. To *decrease* the degree of gate opening, move the stroke adjustment knob away from the gate bracket (see Fig B).

### Step PTO-7:

Repeat the procedure in step PTO-6 until the gate stops firmly (but not sharply) against the open position stop plate. The motor will continue to run for one-half second after the gate opens against the stop plate. If the motor continues to run for more than one second, the push-pull tube is overextended and further adjustment is necessary. If the motor strains too long against the stop plate, the fuse on the control board (above **FIRST OPERATOR** terminal) will be blown. This blade-style 15 ampere fuse (sold by most automotive supply stores) can be easily replaced. **NEVER use a fuse rated higher than 15 amperes!**

**NOTE:** Each time you adjust the knob, finger tighten it before pressing the transmitter button to check your adjustment.

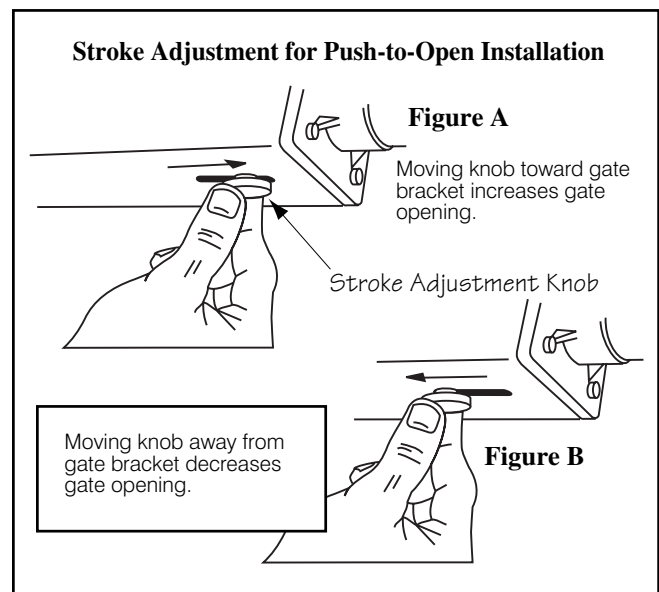
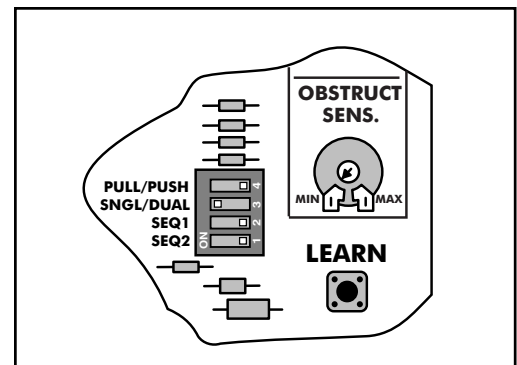

# Maintenance & Troubleshooting Guide

If your gate opener does not function properly after it is installed, use this guide before calling the GTO Service Department.

- On all gates weighing 250 lb. or more, routinely grease the ball bearing hinges at least 4 times a year; more frequently if the gates are near a coastal area.
- Keeping a few mothballs in the control box will discourage insects from entering it and damaging the control board.
- Clean the push-pull tube with a soft, dry cloth and apply silicone spray to it at least once per month.

## If the Opener Does Not Work

### Check the Green LED on the Control Board:

IF THE LED IS OFF: This condition indicates a transformer power failure.

1. Test the transformer for voltage with a voltmeter. The acceptable range can be found in the **VOLTAGE LIMITS** chart on the next page. If the transformer test shows no voltage, then test the electrical outlet for voltage. If the outlet test shows voltage, then the transformer is dead and must be replaced. Allow the new transformer 12 hours to charge the battery before using the gate opener.
2. If the transformer test shows voltage, check the **POWER IN** terminal block on the control board for voltage. If the terminal block shows no voltage, look for broken or spliced wires.

### Check the Red STATUS LED on the Control Board:

IF THE LED IS ON: but the unit is not working.

1. Check the battery in your transmitter and replace with a fresh one if needed..
2. Verify that the power cable is securely connected.
3. Replace the control board fuse if it is blown (**15 ampere fuse only - DO NOT USE A HIGHER RATED FUSE!**).

IF THE LED IS OFF:

1. Make sure the **ON / OFF** switch at the bottom of the control box is set to **ON**.
2. Check all connections for looseness and corrosion.

IF THE LED IS FLASHING:

The system may be in a condition known as "**low voltage lockout**" (i.e., inadequate voltage supplied for the gate opener to function).

1. Test (using a voltmeter) the voltage output of the transformer (18.0 to 22.0 Vac) or solar panel (18.0 to 22.0 Vdc) at the control board power terminal block.
  - A. If the voltage is low or not reading, load test the battery at a electronics store and call your dealer for a replacement battery if necessary.
  - B. If the voltage is low or not reading, test the transformer and electrical outlet. Replace the transformer if necessary and let the battery recharge for 12 hours before using the gate opener.
  - C. Check the control board for damage or corroded connections.
  - D. Make sure that telephone or solid core wire is **not** being used to connect the transformer to the control board.

# If the Opener is Working

## The Gate CLOSSES Then Opens Again on its Own:

1. Check the position of the mounting brackets and readjust if necessary.
2. Check the gate for binding or hinge damage.
3. Check the position of the stroke adjustment knob.

## The Gate OPENS Then Closes Again on its Own:

1. Check the position of the mounting brackets and readjust if necessary.
2. Check the gate for binding or hinge damage.
3. Check the position of the stroke adjustment knob.

### VOLTAGE LIMITS

18 Vac Transformer \_\_\_\_\_ 18.0 to 22.0 Vac

5 W Solar panel (single) \_\_\_\_\_ 18.0 to 22.0 Vdc 300 mA  
measure voltage at panel and control box.

12 V Battery \_\_\_\_\_ 12.0 to 13.5 Vdc 7.0 Ah

Charging circuit \_\_\_\_\_ 12.0 to 14.8 Vdc  
measure voltage with battery connected

The GTO, Inc. Technical Service Department is open  
Monday – Thursday 7:30 A.M. – 5:30 P.M.  
and Friday 8:00 A.M. – 12:00 P.M. (Eastern Time)

**Telephone (800) 543-1236**

**Telephone (850) 575-4144**

**Fax (850) 575-8950 • Web site: [www.gtoinc.com](http://www.gtoinc.com)**

**E-Mail: [techsupport@gtoinc.com](mailto:techsupport@gtoinc.com)**

# Warranty and Repair Service

If your Mighty Mule Gate Opener® is not operating properly, please follow the steps below:

1. First use the procedures found in the *Maintenance & Troubleshooting Guide* (see page 31).
2. If you are unable to solve the problem, call the **GTO Service Department** at (800) 543-1236, or (850) 575-4144. Refer to the serial number (located on the control box cover) and date of purchase when calling for assistance.
3. If repair or replacement of your gate opener is necessary, the Service Department will assign a **Return Goods Authorization (RGA) number** to you.
4. Securely pack the component(s) authorized for return to the factory. Write the RGA number issued to you on the outside of the package in **LARGE BOLD PRINT**. Ship the package(s) freight prepaid to:  
**GTO, Inc., 3121 Hartsfield Road, Tallahassee, Florida, USA 32303.**

**NOTE: Products returned to GTO without a Return Goods Authorization (RGA) number in LARGE BOLD PRINT on the outside of the package WILL NOT be accepted. Also, items returned to GTO freight collect WILL NOT be accepted.**



## One Year Limited Warranty

Your Mighty Mule Gate Opener® is warranted by the manufacturer against defects in materials and manufacturer workmanship for a period of one (1) year from date of purchase, *provided the recommended installation procedures have been followed.*

In the case of product failure due to defective material or manufacturer workmanship within the one (1) year warranty period, the opener will be repaired or replaced (at the manufacturer's option) at no charge to the customer, if returned *freight prepaid* to **GTO, Inc., 3121 Hartsfield Road, Tallahassee, Florida, USA 32303. IMPORTANT: Call (850) 575-4144 or Fax (850) 575-8950 for a Return Goods Authorization (RGA) number before returning item(s) to the factory.** Products shipped to the factory without an RGA number *will not* be accepted. Replacement or repaired parts are covered by this warranty for the *remainder* of the one (1) year warranty period or six (6) months, whichever is greater. GTO will pay shipping costs (equal to United Parcel Service ground rate) for return to owner of item(s) repaired under warranty.

The manufacturer will not be responsible for any damage or cost incurred in the removal of the defective parts for repair, or for the reinstallation of those parts after repair. This warranty shall be considered void if damage to the product was due to improper installation or use, tampering, connection to an improper power source, or if damage was caused by lightning, wind, fire, flood, insects, or other natural agent. This warranty gives you specific legal rights, and you may also have other rights which may vary from state to state. This warranty is in lieu of all other warranties, either expressed or implied. **NOTE: Verification of the warranty period requires copies of receipts or other proof of purchase. Please retain these records.**

After the one (1) year warranty period expires, GTO (or one of its authorized service centers) will perform necessary repairs for a nominal fee. Call GTO at (800) 543-1236 or (850) 575-4144 for more information.

# Column Installation Information

**IF THIS OPENER WILL BE USED WITH GATES THAT ARE MOUNTED ON MASONRY, BRICK, OR ROCK (etc.) COLUMNS:**

**READ THE FOLLOWING CAREFULLY BEFORE PROCEEDING**

Attaching a gate opener to a gate mounted on a masonry column requires special procedures.

Here's how to check your installation to minimize problems:

Open the gate to the 90° position, then measure the distance between the back of the gate and the face of the column. If there is at least a 6 1/4" clearance, you may not have to make any special modifications. However, you *must* measure the post pivot bracket position using 4 1/2" x 4 1/2" setback, as described on page 13 of this manual, to verify that the gate hinge sits far enough from the column to give your installation the proper setback distance.

If you do not have the proper clearance or setback distance, the opener may operate the gate for a while, but eventually the unit will become nonfunctional. To prevent this problem, we suggest the following installation method:

- A. The simplest solution is to install the opener in a push-to-open configuration (requires Push-To-Open Bracket, see Accessory Catalog). The crucial 4 1/2" setback is easier to achieve and clearance is no longer a problem, since the opener will be pushing the gate away from the column instead of pulling it toward the column. It is recommended that you place a steel plate between the opener mounting brackets and masonry surface for additional strength.
- B. If a push-to-open installation is impossible due to traffic hazards, terrain, etc., another option is to re-hang the gate. You may hang it on a post, either in the center of the column or at the back corner, or move the gate to the back corner of the columns.
- C. The most difficult solution is to cut a notch in the column to accommodate the opener and power cable. This job is **NOT** for the inexperienced!

Because of the difficulty associated with column installations, we **STRONGLY** advise you to call the **GTO Service Department** at (800) 543-1236 or (850) 575-4144 for assistance *prior* to your installation.



## **Accessory Catalog**

## These Accessories are Available From Your Retail Store

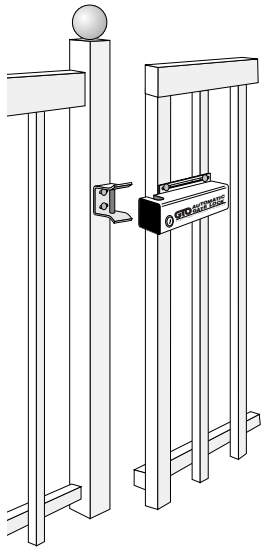

### Automatic Gate Lock Pull-to-Open (FM143)

A MUST for securing the gate against forced entry or exit. Solenoid driven, plated steel bolt lock with a zinc plated steel housing. The horizontal electronic lock is used with the **Mighty Mule**<sup>®</sup> system for maximum stability and security. Recommended for gates over 8 feet long or where high winds are common.

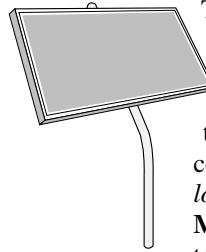

### Solar Panel (FM121) *(has a 2 year warranty)*

The **Solar Panel** is a solar powered battery charger for use with the **Mighty Mule**<sup>®</sup> gate opener system. Particularly suited for remote installations, the **Solar Panel** comes with tubular steel support, mounting clips, wire connectors, and 8 ft. of low voltage wire (*for longer length wire, see RB509 below*). The **Mighty Mule**<sup>®</sup> control board has clearly labeled terminal connections for easy installation of the **Solar Panel**. Installation in some regions of the world may require dual solar panels for adequate charging power.



### GTO Digital Keypad (FM137)

The specially designed digital keypad can be easily installed as a wireless or wired keypad. It can be programmed to use up to fifteen different personal identification number (PIN) codes. Each code is face programmable with additional security features built in. Requires 3 AA batteries (*not included*).



### Mighty Mule Entry Transmitter (FM135)

The **Mighty Mule**<sup>®</sup> entry transmitter, with adjustable code settings, is standard equipment with **Mighty Mule**<sup>®</sup> systems. Battery included.



### Push Button (Doorbell) Control (FM132)

Unlighted doorbell button for remote entry or exit control. Connects directly to the control board and uses 16 gauge, multi-stranded low voltage wire (*not included*).

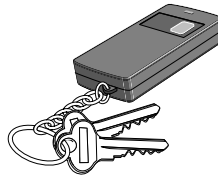

### Key Chain Mini Transmitter (FM134)

The Key Chain Mini Transmitter is a miniature version of the **Mighty Mule**<sup>®</sup> entry transmitter and has the same adjustable code settings. Battery included.

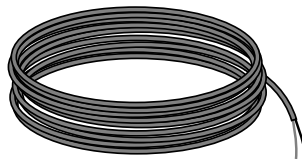

### Low Voltage Wire (RB509)

The 16 gauge, multi-stranded, dual conductor **Low Voltage Wire** connects the AC powered transformer or the solar powered battery charger (**Solar Panel**) to the control board. Also used for the connection of accessories, such as locks, keypads, push buttons and other wired control devices. This specially designed wire is UV treated, PVC coated and ready for direct burial. Available in 1000' rolls or special lengths.

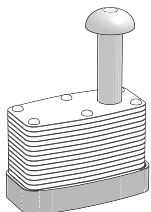

### Pin Lock (FM133)

The **Pin Lock** substitutes for the clevis pin at the front mounting point of the opener. Helps prevent theft of the opener from the gate, while allowing quick release of the opener.

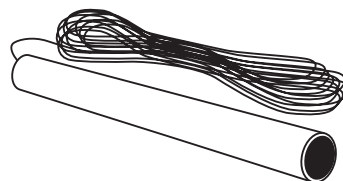

### Gate Opening Sensor (FM138)

The Gate Opening Sensor is designed for residential and agricultural applications and is compatible with the **Mighty Mule** automatic gate opener models. The Gate Opening Sensor is an electromagnetic sensor, which offers 'hands free' operation of the **Mighty Mule** Automatic Gate Opener with a 12 ft. radius of detection of vehicles in motion.



## The Following Accessories Are Available Through Your Retail Store's Special Order Desk.

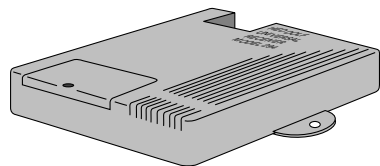

### Garage Door Receiver (RB709)

The Garage Door Receiver allows you to use the same **Mighty Mule®** entry transmitter (see *dual and triple transmitters*) to operate your gate opener and your garage door opener. Compatible with most garage door openers.

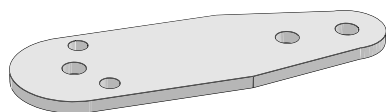

### Push To Open Bracket (348IH)

Required when the **Mighty Mule Gate Opener®** must push the gate open, such as on a sloping driveway, or where space prevents gate from being pulled open.

### Dual Transmitter (RB742)

The Dual Transmitter is a two button transmitter for remote control of two separate gate openers, or a gate opener and garage door opener (see *Garage Door Receiver*). Battery included.

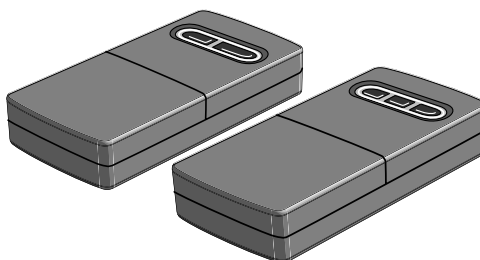

### Triple Transmitter (RB743)

The Triple Transmitter is a three button transmitter for remote control of three separate gate openers and/or garage door openers (see *Garage Door Receiver*). Battery included.

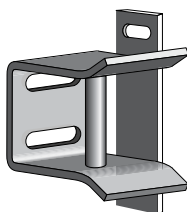

### Column Mount Lock Receiver (433IH)

For mounting the **Automatic Gate Lock (FM143)** on brick columns, walls, or for other applications with limited space between gate and post.

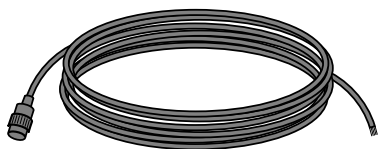

### Power Cables

The **AW201** four and one-half foot power cable is included with **Mighty Mule** gate opener systems.

The **AW240** forty foot power cable allows you to mount the control box in a remote location.

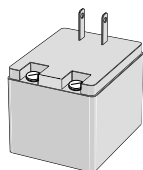

### Replacement Transformer (RB566)

Standard 18 volt AC transformer for maintaining the battery included with the **Mighty Mule®** gate opener. This is the only transformer approved for use with the **Mighty Mule®**.

**If you have a question about any special order item,  
just call 1-800-543-GATE!**

## The Following Replacement Parts Are Available Through Your Retail Store's Special Order Desk.



### Replacement Battery (RB500)

Standard 12 volt, 7.0 ampere-hour, maintenance-free battery for the **Mighty Mule** gate opener. Only this battery is approved for use with the **Mighty Mule**. Battery life 3 to 5 years.

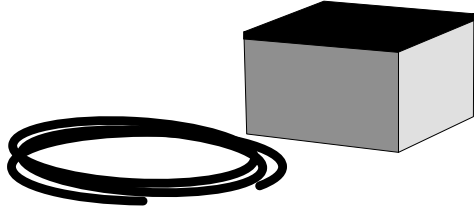

### 24 Amp Hour Battery Kit (FP296)

This large 12 volt, 24 ampere-hour, maintenance-free battery is for the **Mighty Mule** gate operators. It will supply additional power for increasing the number of open and close cycles. The kit comes with the battery and wiring harness for easy installation. Battery life 3 to 5 years. Enclosure not provided.



For sales call toll free:  
**1-800-543-GATE**

For technical service Call toll free:  
**1-800-543-1236**

### **Mighty Mule® Limited One Year Warranty:**

GTO, Inc., gate openers and accessories are warranted by the manufacturer against defects in materials and manufacturer workmanship for a period of one (1) year from date of purchase, *provided the recommended installation procedures have been followed.*

In the case of product failure due to defective material or manufacturer workmanship within the one (1) year warranty period, the product will be repaired or replaced (at the manufacturer's option) at no charge to the customer, if returned freight prepaid to GTO, Inc., 3121 Hartsfield Road, Tallahassee, Florida, USA 32303. **IMPORTANT: Call (850) 575-4144 or Fax (850) 575-8950 for a Return Goods Authorization (RGA) number before returning accessory to factory.** Products received at the factory without an RGA number will not be accepted. Replacement or repaired parts are covered by this warranty for the *remainder* of the one (1) year warranty period or six (6) months, whichever is greater. GTO, Inc. will pay the shipping charges (equal to United Parcel Service GROUND rate) for return to the owner of items repaired under warranty.

The manufacturer will not be responsible for any charges or damages incurred in the removal of the defective parts for repair, or for the reinstallation of those parts after repair. This warranty shall be considered void if damage to the product(s) was due to improper installation or use, connection to an improper power source, or if damage was caused by lightning, wind, fire, flood, insects or other natural agent.

After the one (1) year warranty period, GTO, Inc. or one of its authorized service centers will make any necessary repairs for a nominal fee. Call GTO at (800) 543-1236 for more information. This warranty gives you specific legal rights, and you may also have other rights which may vary from state to state. This warranty is in lieu of all other warranties, expressed or implied. **NOTE: Verification of the warranty period requires copies of receipts or other proof of purchase. Please retain these records.**

**GTO, Inc.**

3121 Hartsfield Road • Tallahassee, Florida, USA 32303 • (850) 575-0176 • Fax (850) 575-8912 • Web site [www.gtoinc.com](http://www.gtoinc.com)