

# Installation Manual



**WARNING!**



This equipment is similar to other gate or door equipment and meets or exceeds Underwriters Laboratory Standard 325 (UL 325). However, gate equipment has hazards associated with its use and therefore by installing this product the installer and user accept full responsibility for following and noting the installation and safety instructions. Failure to follow installation and safety instructions can result in hazards developing due to improper assembly. You agree to properly install this product and that if you fail to do so GTO Access Systems, LLC, shall in no event be liable for direct, indirect, incidental, special or consequential damages or loss of profits whether based in contract tort or any other legal theory during the course of the warranty or at any time thereafter. The installer and/or user agree to assume responsibility for all liability and use of this product releasing GTO Access Systems, LLC, from any and all liability. If you are not in agreement with this disclaimer or do not feel capable of properly following all installation and safety instructions you may return this product for full replacement value.

**READ ALL INSTRUCTIONS CAREFULLY AND COMPLETELY** before attempting to install and use this automatic gate opener. This gate opener produces a high level of force. Stay clear of the unit while it is operating and exercise caution at all times.

All automatic gate openers are intended for use on **vehicular gates only**.



This product meets and exceeds the requirements of UL 325, the standard which regulates gate operator safety, by Underwriters Laboratories Inc.



For more information on Mighty Mule's full line of Automatic Gate Openers and Access Controls visit our website at [www.mightymule.com](http://www.mightymule.com)

GTO Sales: 800-543-4283 • Fax 850-575-8912

GTO Technical Service 800-453-1236

For 24 hour/day, 7 day/week Technical Service visit <http://support.gtoinc.com>

For more information on Mighty Mule's full line of Automatic Gate Openers and Access Controls visit [www.mightymule.com](http://www.mightymule.com)

# U.L. Gate Operator Classifications

**Residential Vehicular Gate Operator—Class I:** A vehicular gate operator (or system) intended for use in a home of one-to-four single family dwelling, or a garage or parking area associated therewith.

**Commercial/General Access Vehicular Gate Operator—Class II:** A vehicular gate operator (or system) intended for use in a commercial location or building such as a multifamily housing unit (five or more single family units), hotel, garages, retail store, or other building servicing the general public.

**Industrial/Limited Access Vehicular Gate Operator—Class III:** A vehicular gate operator (or system) intended for use in an industrial location or building such as a factory or loading dock area or other locations not intended to service the general public.

**Restricted Access Vehicular Gate Operator—Class IV:** A vehicular gate operator (or system) intended for use in a guarded industrial location or building such as an airport security area or other restricted access locations not servicing the general public, in which unauthorized access is prevented via supervision by security personnel.

## Product Usage

The Mighty Mule Gate Opener meets all of the safety requirements of a **Class I** Residential Vehicular Gate Operator and is intended for use solely with vehicular swing gates in single-family residential applications.

The Mighty Mule Gate Opener system certified to be in compliance with the following safety standards (current edition as of publication date):



Product in compliance with the latest UL-325 and UL-991 safety standards by ETL. Product in compliance with CAN/CSA-C22.2 No. 247-92.



Product in compliance with IEC 60335-2-103:2003 and IEC 60335-1:2004, including A1:2004.

### *Converting Metric Units to English Equivalents*

When You Know	Multiply By	To Find	Symbol
centimeters	0.3937	inches	in. (or ")
meters	3.2808	feet	ft. (or')
kilograms	2.2046	pounds	lb. (or #)

### *Converting English Units to Metric Equivalents*

When You Know	Multiply By	To Find	Symbol
inches	2.5400	centimeters	cm
feet	0.3048	meters	m
pounds	0.4535	kilograms	kg

### *Converting Temperature*

deg. Celsius	$(^{\circ}\text{C} \times 1.8) + 32$	deg. Fahrenheit	$^{\circ}\text{F}$
deg. Fahrenheit	$(^{\circ}\text{F} - 32) \div 1.8$	deg. Celsius	$^{\circ}\text{C}$

## FOR YOUR RECORDS

Please record the following information product serial number (located on the rear of opener arm), be sure to **keep all receipts for proof of purchase**. Refer to this information when calling GTO for service or assistance with your automatic gate opener.

Serial Number: \_\_\_\_\_ Date of Purchase: \_\_\_\_\_

Place of Purchase: \_\_\_\_\_

# Table Of Contents

Please Read This First .....	ii
Important Safety Instructions .....	iii–viii
How to Manually Open and Close the Gate:.....	iii
For the Consumer .....	iv
Required Safety Precautions for Gates .....	vi
Secondary Means of Protection Against Entrapment .....	vii
Entrapment Alarm (UI 325; 30A.1.1A) .....	vii
Technical Specifications .....	1
Before You Begin.....	2
Solar Panel and Gate Activity Chart.....	2
Parts List – Opener and Mounting Hardware .....	4
Tools and Materials .....	5
Installation Overview for Pull-To-Open Gates .....	6
Installation of the First Gate Opener .....	7
Install Post Bracket Assembly and Gate Bracket .....	8
Attach Opener Arm .....	10
Install the Closed Position Stop Plates .....	11
Mount the Control Box.....	12
Connect Opener Power Cables.....	13
Connect the Transformer .....	13
Connect Battery Harness to Control Board.....	15
Connect the Battery .....	16
Set the Closed Position Limit.....	16
Adjust the Stall Force Setting .....	17
Set Auto-Close Time .....	17
Personalize Your Transmitter Setting .....	18
Push-To-Open Installation Instructions .....	19
Solar Panel Instructions.....	21
Connecting Accessories and Safety Devices .....	22
Troubleshooting Guide.....	24
Gate and Opener Maintenance .....	25
Warranty Repair.....	25
Accessories.....	26

# PLEASE READ THIS FIRST



Thank you for purchasing a Mighty Mule 362-D Gate Opener—GTO's "do-it-yourself" automatic gate opener! When correctly installed and properly used, your Mighty Mule Gate Opener will give you many years of reliable service. Please read the following information and watch the enclosed video to ensure you have the correct system for your particular needs. Furthermore, this manual and the video will enable you to properly install your Mighty Mule Gate Opener.

The Mighty Mule 362-D Gate Opener is designed for installation on **Pull-To-Open dual gate leaves** (gates that open *into* the property). By purchasing accessory brackets [FM148], the Mighty Mule 362-D Gate Opener can accommodate **Push-To-Open dual gate leaves** (gates that open *out* from the property). Please see Pull-To-Open/Push-To-Open diagram on page 3. The gates must not exceed 12 ft. or 300 lbs. per leaf (see Technical Specifications on page 1). The Mighty Mule Gate Opener can be used on vinyl, aluminum, chain link, farm tube, and wrought iron gates.

**Use on solid (surface) gates is not recommended. Solid surface gates have a high resistance to the wind. If the wind is strong enough, the opener will obstruct and stop, blow fuses, or may damage the equipment.**

The Mighty Mule Gate Opener features an **adjustable stall force** setting. This safety feature makes the gate stop and reverse direction within 2 seconds when it comes in contact with an obstruction. The MIN setting; means the gate will exert the minimum force on an obstruction before it stops and reverses direction. **You will need to adjust the stall force for your particular application.**

The Mighty Mule Gate Opener also has an **adjustable auto-close** feature. After the gate reaches the fully open position, it can be set for OFF, or to remain open up from 3 to 120 seconds before automatically closing. Pressing the transmitter button at any time after the gate opens fully will cause it to close immediately. The auto-close factory setting is OFF, meaning the gate will stay open until you press the transmitter (or keypad, etc.) again.

The Mighty Mule Gate Opener accommodates extra transmitters, digital keypads, solar panels, push buttons, automatic gate locks, and other access control products. These optional accessories (page 26) are available at Tractor Supply stores or through Special Order (if the accessory is not in stock). If your store cannot special order accessories, please call the GTO Sales Department (800/543-GATE) or visit [www.mightymule.com](http://www.mightymule.com).

**PLEASE NOTE—If your application requires any of the following:**

- Column Mounting**
- Slide gates**
- Swing gates longer than 12 feet or weighing more than 300 pounds**
- Professional installation**

please call GTO at 800/543-GATE (4283) for information about our GTO/ACCESS SYSTEMS professional line of gate openers and accessories. Our Sales Department will be glad to give you the name and phone number of a GTO/ACCESS SYSTEMS dealer near you.

## **BEFORE YOU BEGIN TO INSTALL YOUR AUTOMATIC GATE OPENER:**

**Watch the enclosed video and read these instructions *carefully* and *completely* to become familiar with all parts and installation steps. The video is only designed as an overview of the installation procedure. You must read the installation manual for detailed instructions on gate opener safety and proper use of the gate opener.**

# IMPORTANT SAFETY INSTRUCTIONS



Because automatic gate openers produce high levels of force, consumers need to know the potential hazards associated with improperly designed, installed, and maintained automated gate opener systems. *Keep in mind that the gate opener is just one component of the total gate operating system.* Each component must work in unison to provide the consumer with convenience, security, and safety.

This manual contains various safety precautions and warnings for the consumer. Because there are many possible applications of the gate opener, the safety precautions and warnings contained in this manual cannot be completely exhaustive in nature. They do, however, provide an overview of the safe design, installation, and use of this product. **CAREFULLY READ AND FOLLOW ALL SAFETY PRECAUTIONS, WARNINGS, AND INSTALLATION INSTRUCTIONS TO ENSURE THE SAFE SYSTEM DESIGN, INSTALLATION, AND USE OF THIS PRODUCT.**

Precautions and warnings in this manual are identified with this  warning symbol. The symbol identifies conditions that can result in damage to the opener or its components, serious injury, or death.

**Because GTO automatic gate openers are only part of the total gate operating system, it is the responsibility of the consumer to ensure that the total system is safe for its intended use.**

## How To Manually Open and Close the Gate:

 **CAUTION:** The gate can be opened and closed manually when the opener is disconnected. **ONLY** disconnect the opener when the opener power switch is OFF and the gate is NOT moving.

### Disconnecting the Opener

1. Turn opener power switch (Control Box) OFF.
2. Remove hairpin clip, clevis pin, and bushing from both the front and rear mounting points.
3. Remove the opener from the mount.

**IMPORTANT: NEVER allow opener arm to hang by the front or rear mount — it will break from the arm weight.**

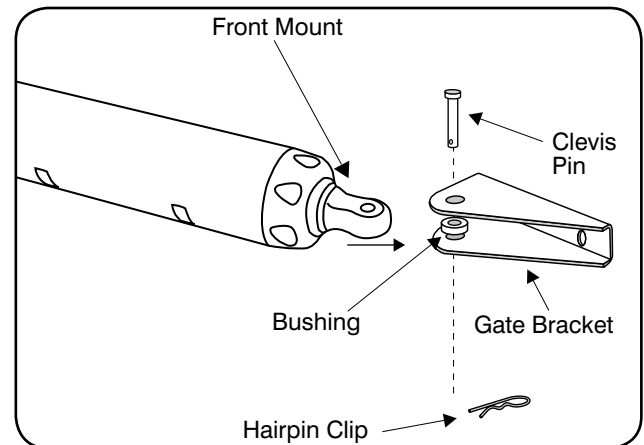

 **CAUTION:** Because the Mighty Mule gate opener is battery powered, disconnect the opener **ONLY** when the power switch on the control box is turned OFF. Unplugging the transformer does not turn power to the opener OFF.

NOTE: Substitute a Pin Lock [FM133] for the clevis pin on the front mount of the gate opener to prevent unauthorized removal of the opener from the gate (page 26).

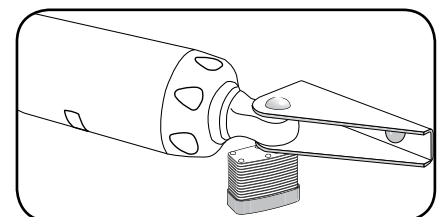



# IMPORTANT SAFETY INSTRUCTIONS

## For The Consumer

### **WARNING:** To reduce the risk of injury or death:

1. **READ AND FOLLOW ALL INSTRUCTIONS.** Failure to meet the requirements set forth in the instruction manual could cause severe injury or death, for which the manufacturer cannot be held responsible.
2. When designing a system that will be entered from a highway or main thoroughfare, make sure the system is placed far enough from the road to prevent traffic congestion.
3. The gate must be installed in a location that provides adequate clearance between it and adjacent structures when opening and closing to reduce the risk of entrapment. Swinging gates must not open into public access areas.
4. The gate and gate opener installation **must comply with any applicable local codes.**

### I. Before Installation

1. Verify this opener is proper for the type and size of gate, its frequency of use, and the proper class rating.
2. Make sure the gate has been properly installed and swings freely in both directions. Repair or replace all worn or damaged gate hardware prior to installation. A freely moving gate will require less force to operate and will enhance the performance of the opener and safety devices used with the system.
3. Review the operation of the system to become familiar with its safety features. Understand how to disconnect the opener for manual gate operation (page iii).
4. This gate opener is intended for vehicular gates **ONLY**. A separate entrance or gate must be installed for pedestrian use (page vi).
5. Always keep people and objects away from the gate and its area of travel. **NO ONE SHOULD CROSS THE PATH OF A MOVING GATE.**
6. Pay close attention to the diagram below and be aware of these areas at all times.

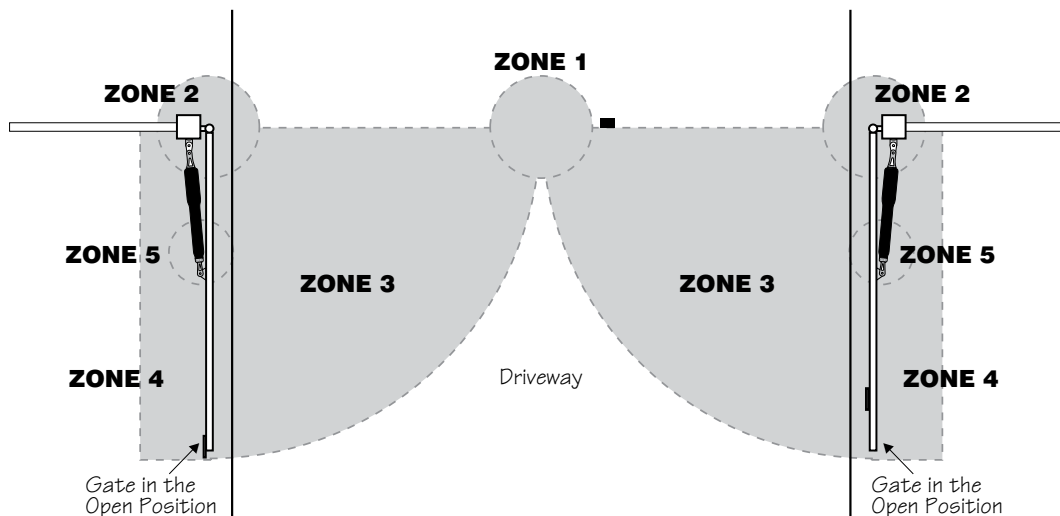

### Entrapment Zones for a proper Pull-To-Open installation:

- Zone 1** – leading edge of the gates.
- Zone 2** – between the gate and the gate post.
- Zone 3** – the path of the gate.
- Zone 4** – the space between the gate in the open position and any object such as a wall, fence, etc.
- Zone 5** – pinch points between the opener and gate.

# IMPORTANT SAFETY INSTRUCTIONS



## II. During Installation

1. Install the gate opener on the inside of the property and fence line. **DO NOT** install an opener on the outside of the gate where the public has access to it.
2. Be careful with moving parts and avoid close proximity to areas where fingers or hands could be pinched.
3. Devices such as contact sensors (safety edges) and non contact sensors (photo beams) provide additional protection against entrapment.
4. If push buttons or keypads are installed, they should be within sight of the gate, yet located at least 10 feet from any moving part of the gate (see diagram below). **Never install any control device where a user will be tempted to reach through the gate to activate the gate opener.**
5. Do not activate your gate opener unless you can see it and can determine that its area of travel is clear of people, pets, or other obstructions. Watch the gate through its entire movement.
6. Secure outdoor or easily accessed gate opener controls in order to prohibit unauthorized use of the gate.

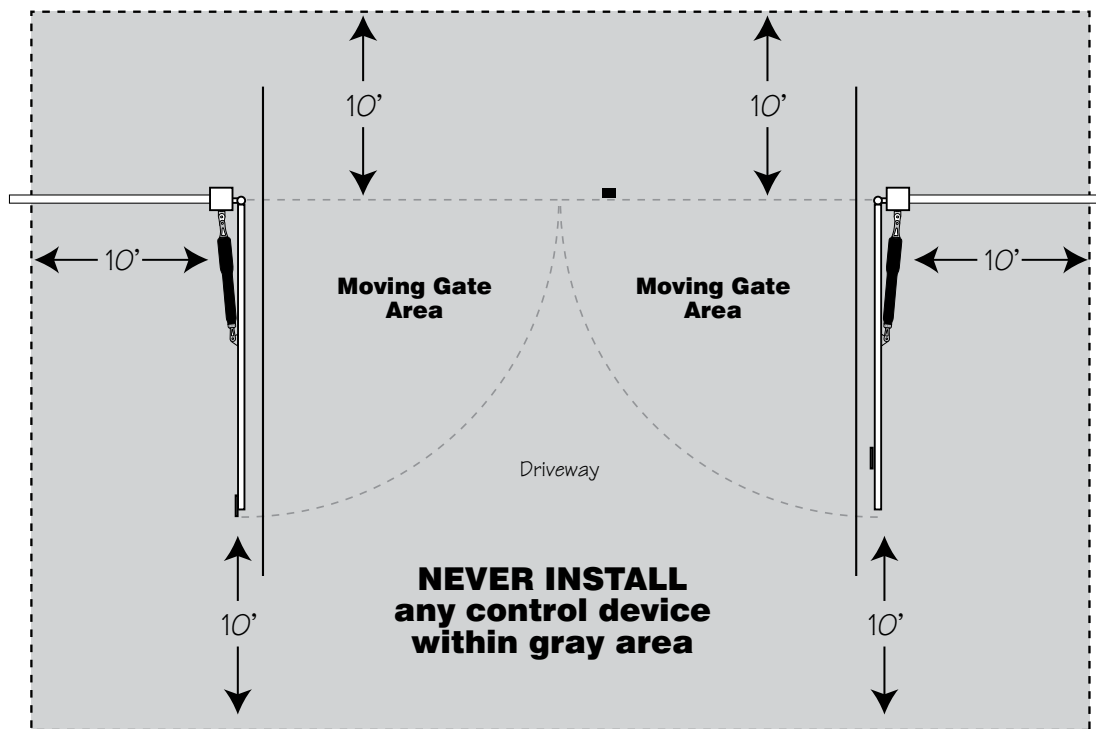

## III. After Installation

1. Attach the **warning signs** (included) to each side of the gate to alert the public of automatic gate operation. It is **your responsibility** to post warning signs on both sides of your gate. If any of these signs or warning decals become damaged, illegible or missing, replace them immediately. Contact GTO for free replacements.
2. The gate is automatic and could move at any time, posing a serious risk of entrapment. No one should be in contact with an activated gate when it is moving or stationary.
3. Do not attempt to drive into the gate area while the gate is moving; wait until the gate comes to a complete stop.
4. Do not attempt to "beat the gate" (drive through) while the gate is closing. This is extremely dangerous.
5. Do not allow children or pets near your gate. **Never let children operate or play with gate controls.** Keep ALL gate controls away from children and unauthorized users; store controls where children and unauthorized users do not have access to them.
6. **KEEP GATE AND GATE OPENER PROPERLY MAINTAINED.** Always turn power to opener OFF before performing any maintenance. Regularly grease the gate hinges. Clean the push-pull tube with a soft, dry cloth and apply silicone spray to it at least once per month.



# IMPORTANT SAFETY INSTRUCTIONS

7. To operate this equipment safely, YOU must know how to disconnect the opener for manual gate operation (page iii). If you have read the instructions and still do not understand how to disconnect the opener, contact the GTO Service Department.
8. Disconnect the opener **ONLY** when the power is **TURNED OFF** and the gate is **NOT** moving.
9. Make arrangements with local fire and law enforcement for emergency access.
10. Distribute and discuss copies of the **IMPORTANT SAFETY INSTRUCTIONS** section of this manual with all persons authorized to use your gate.
11. **IMPORTANT: Save these safety instructions. Make sure everyone who is using or will be around the gate and gate opener are aware of the dangers associated with automated gates. In the event you sell the property with the gate opener or sell the gate opener, provide a copy of these safety instructions to the new owner.**

Should you lose or misplace this manual, a copy can be obtained by downloading one from the Mighty Mule web site ([www.mightymule.com](http://www.mightymule.com)), by contacting GTO Access Systems, LLC., at 3121 Hartsfield Road, Tallahassee, Florida 32303 or by calling 1-800-543-4283 and requesting a duplicate copy. One will be provided to you free of charge.

## Required Safety Precautions for Gates

### Install Warning Signs

**Warning signs** alert people of automatic gate operation and are **required** when installing the Mighty Mule Gate Opener. The Warning Signs included must be installed on both sides of each gate. Furthermore, a walk-through gate must be installed if pedestrian traffic is expected near the vehicular gate. We recommend using the GTO Bulldog Pedestrian Gate Lock [FM145] (page 26) for controlled access.

### Entrapment Protection

GTO's inherent obstruction settings, even when properly adjusted, **may not be sensitive enough to prevent bodily injury in some circumstances**. For this reason, safety devices such as safety edge sensors (or photoelectric sensors), which stop and reverse gate direction upon sensing an obstruction, are suggested for enhanced protection against entrapment.

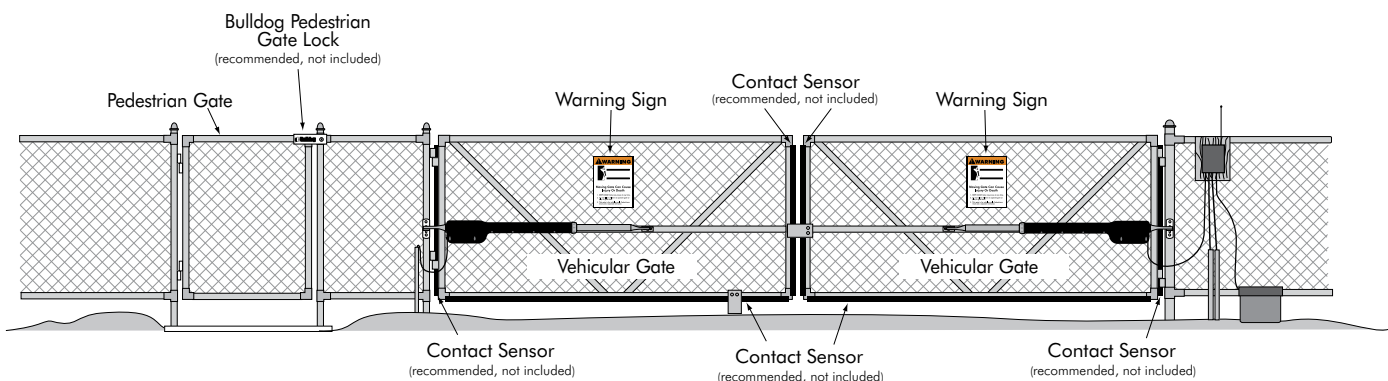



# IMPORTANT SAFETY INSTRUCTIONS



## Secondary Means of Protection Against Entrapment

As specified by Gate Opener Safety Standard, UL 325 (30A.1.1), automatic gate openers shall have an inherent entrapment sensing system, and shall have *provisions for, or be supplied with*, at least one independent secondary means to protect against entrapment. The Mighty Mule utilizes **Type A**, an inherent (i.e., built-in) entrapment sensing system as the **primary** type of entrapment protection. Also, the Mighty Mule has *provisions for* the connection of **Type B2** protection to be used as the **secondary** type of entrapment protection, if desired.

1. For gate openers utilizing a contact sensor (e.g., safety edge sensor– Type B2) in accordance with UL 325 (51.8.4 [i]):
  - A. One or more contact sensors shall be located at the leading edge, bottom edge, and post edge, both inside and outside of a vehicular swing gate system.
  - B. A hard wired contact sensor shall be located and its wiring arranged so that the communication between the sensor and the gate opener is not subjected to mechanical damage.
  - C. A wireless contact sensor such as one that transmits radio frequency (RF) signals to the gate opener for entrapment protection functions shall be located where the transmission of the signals are not obstructed or impeded by building structures, natural landscaping or similar obstruction. A wireless contact sensor shall function under the intended end-use conditions.

You may want to consider adding photo beams to your installation. GTO Photo Beams [R4222] provide a “non contact” means of entrapment protection.

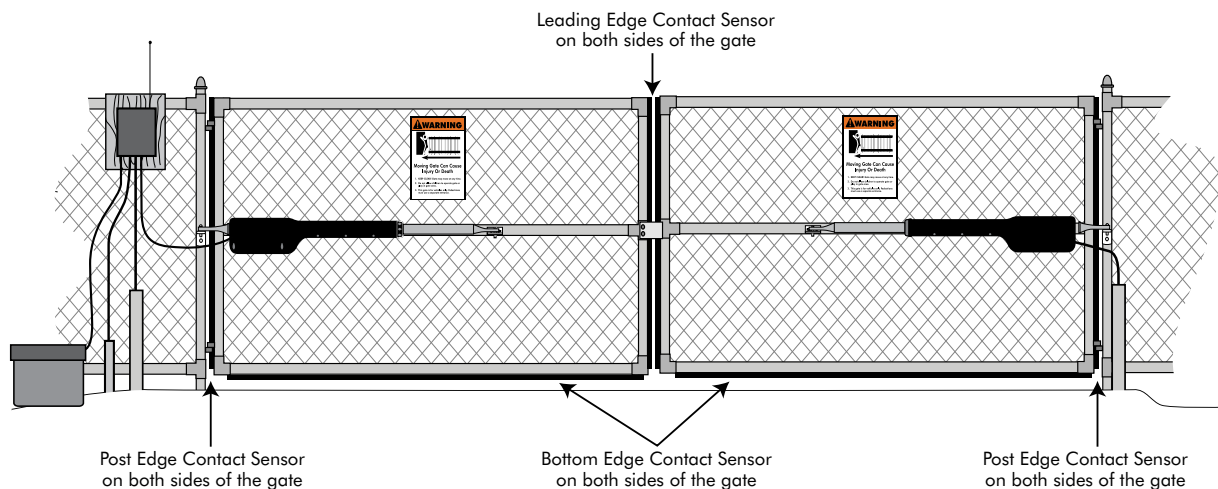

### ENTRAPMENT ALARM (UL 325; 30A.1.1A)

The Mighty Mule Gate Opener is designed to stop and reverse within 2 seconds when the gate comes in contact with an obstruction. Additionally, these openers are equipped with an **audio entrapment alarm** which will activate if the unit obstructs **twice** while opening or closing. This alarm will sound for a period of 5 minutes, or until the opener receives an intended signal from a hard wired entry/exit source (e.g. push button control or keypad) and the gate returns to a fully open or fully closed position. Turning the power switch on the control box OFF and back ON will also deactivate the alarm. Wireless controls such as transmitters and wireless keypads will not deactivate the alarm.



# IMPORTANT SAFETY INSTRUCTIONS

## **WARNING**

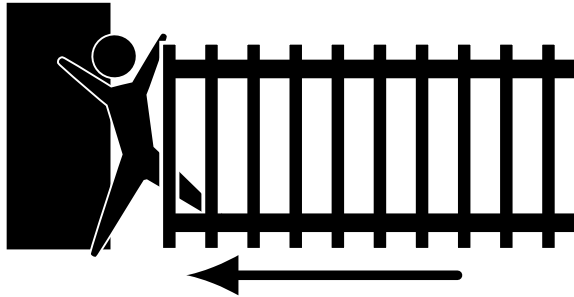

### **Moving Gate Can Cause Injury Or Death**

- 1. KEEP CLEAR! Gate may move at any time.**
- 2. Do not allow children to operate gate or play in gate area.**
- 3. This gate is for vehicles only. Pedestrians must use a separate entrance.**



*Product identification label (2) installed under rear mount of each arm*

*Warning signs (4 enclosed) MUST be installed on both sides of each gate (3-5 feet above the bottom of the gate)*



[www.mightymule.com](http://www.mightymule.com)  
1-800-543-GATE (4283)

#### TO MANUALLY OPEN AND CLOSE THE GATE

1. Turn opener power switch OFF.
2. Disconnect front and rear mount from mounting brackets.
3. Remove opener from mounting brackets and move gate. Disconnect opener ONLY when the power switch is OFF and the gate is not moving.

#### **Control box label (1)**

*installed on front of the control box*

## **MM362-D** **AUTOMATIC GATE OPENER**

1-800-543-GATE (4283) • [www.mightymule.com](http://www.mightymule.com)



## **WARNING**

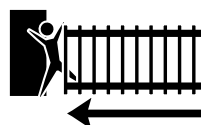

### **MOVING GATE Can Cause Injury or Death**

- 1. KEEP CLEAR! Gate may move at any time.**
- 2. Do not allow children to operate gate or play in gate area.**
- 3. This gate is for vehicles only. Pedestrians must use separate entrance.**

Maximum Gate: 300 lbs. (136.1 kg); 12 ft. (3.7 m) • Voltage: 12 Vdc;  
Frequency: 0Hz; Power: 25W • Class I and II Vehicular Swing Gate Operator

#### **Logo and warning labels (4)**

*installed on each side of opener housings*

# Technical Specifications

## MIGHTY MULE 362-D GATE OPENER

### DRIVE

- Low friction screw drive (linear actuator) rated for -5 °F to +160 °F (-20 °C to +71 °C).
- Powered by a 12 V motor with integral case hardened steel gear reducer. Motor speed reduced to 260 rpm. Generates 520 inch lb. of torque at 12 V.
- Maximum opening arc of 110°. Approximate opening time (90°): 18 seconds, depending on weight of gate.

### POWER

- The system is powered by a 12 Vdc automotive or lawn tractor battery.
- Battery charge is maintained by a 120 Vac, 14 Vac output transformer (10 VA) through the GTO control board] or by optional GTO Solar Panels; the panel should generate minimum of 10 Watts (600 mA). A diode on the control board prevents battery discharge. **IMPORTANT:** Never use *both* transformer and solar panel— this will damage the battery and control board.
- One (1) blade-style fuse is rated for 15 A.

**NOTE: The transformer should not be directly connected to any battery. Do not replace fuses with higher ampere rated fuses; doing so will void your warranty and may damage your control board.**

### CONTROL

- **GTO** microprocessor-based control board is set for dual leaf, pull-to-open gate installations. Jumper can be removed to accommodate an optional kit for push-to-open gates.
- Control board has temperature compensated circuits.
- A circuit on the control board regulates charging. "Sleep draw" is 15 mA; "active draw" is 2 to 5 A.
- Auto-memorization of digital transmitter code.
- GTO RF receiver tuned to 318 MHz.
- Opener length with push-pull tube fully retracted is 26 3/8", mounting point to mounting point. Maximum stroke is 13".
- Adjustable auto-close timer (OFF to 3–120 seconds), and obstruction sensitivity (stall force).
- Power terminal block accommodates a transformer or solar panels.
- Accessory terminal block fully compatible with all Mighty Mule access controls.
- Control board allows connection of safety edge sensors and photoelectric sensors.
- Audio entrapment alarm sounds if unit encounters an obstruction twice while opening or closing.

### OPERATIONAL CAPACITY

- The Gate Capacity Chart shows approximate cycles, per day, you can expect from the Mighty Mule 362-D Automatic Gate Opener when powered with a transformer. Actual cycles may vary slightly depending upon the type and condition of gate and installation.

*An operation cycle is one full opening and closing of the gate.*

<b>Mighty Mule 362 Gate Capacity/Cycle Chart</b>					
<i>Estimated number of daily cycles, based on use with a transformer.</i>					
<b>Number of Cycles Per Day</b>					
<b>Gate Weight</b>	<b>300 lbs.</b>	<b>39</b>	<b>36</b>	<b>34</b>	<b>31</b>
	<b>150 lbs.</b>	<b>41</b>	<b>39</b>	<b>36</b>	<b>34</b>
	<b>100 lbs.</b>	<b>44</b>	<b>41</b>	<b>39</b>	<b>36</b>
	<b>50 lbs.</b>	<b>46</b>	<b>44</b>	<b>42</b>	<b>39</b>
		<b>5' - 6'</b>	<b>8'</b>	<b>10'</b>	<b>12'</b>
<b>Gate Length</b>					

\* These specifications are subject to change without notice.

**NOTE: BALL BEARING HINGES SHOULD BE USED ON ALL GATES WEIGHING OVER 250 LB.**

To determine the number of cycles the gate opener will perform using solar panels, please see the specifications listed on page 2 or call (800) 543-1236 or (850) 575-4144 for more information.

# Before You Begin

## 1. Determine Charging Options for Battery: Transformer OR Solar

**NEVER USE TRANSFORMER AND SOLAR PANEL(S) AT THE SAME TIME!  
It will damage the control board!**

### IMPORTANT

- The Mighty Mule 362-D is designed and intended for use with a 12 Volt automotive or lawn tractor battery. The battery must be placed inside a weatherproof case and located within 6' of the control box. **The 8' battery harness connects the battery to the control board.**
- The battery charge is maintained by the 14 Volt transformer included **OR** optional solar panel(s). The transformer **OR** solar panel is connected to the control board using low voltage, 16 gauge, dual conductor, multi-stranded, direct burial wire [RB509] (page 26).
- All low voltage wire used with the Mighty Mule Gate Opener must be 16 gauge dual conductor, multi-stranded, direct burial wire.
- The transformer is intended for indoor use. If the transformer can only be plugged into an outside electrical outlet, a weatherproof cover or housing **must** be used.
- If your gate is more than 1000' from an AC power source, you will need to use a solar panel charging kit (**minimum 10 watts**) . Refer to the Solar Panels and Gate Activity Chart below.

## Solar Panel and Gate Activity Chart

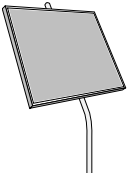

The table and map illustrate the maximum number of gate cycles to expect per day in a particular area when using from 10 to 20 watts of solar charging power. The figures shown are for winter (minimum sunlight) and do not account for the use of any accessory items.

**Accessories connected to your system will draw additional power from the battery and will require additional solar panels.**

NOTE: UP to 250 ft. of dual conductor, 16 gauge, multi-stranded wire may be used to allow installation of solar panels in direct sunlight.

See page 26:

10 Watt Solar Panel [FM123]

5 Watt Solar Panel [FM121]

Dual Gate Winter Ratings	Zone 1	Zone 2	Zone 3
10 Watts	8	16	26
15 Watts	11	20	30
20 Watts	14	28	38

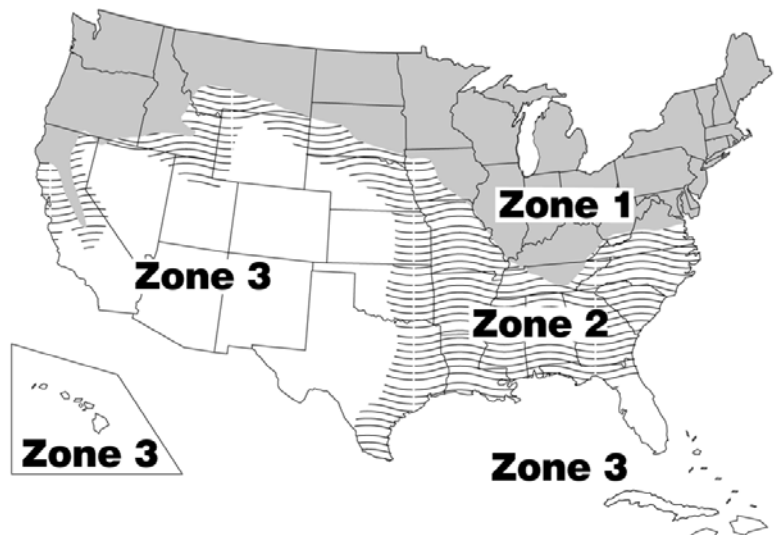

## 2. Check Direction of Gate Swing

The Mighty Mule is designed for **PULL-TO-OPEN** installations. **PUSH-TO-OPEN** installations require two Push-To-Open brackets [FM148]. Push-to-Open Installation Instructions begin on page 19.

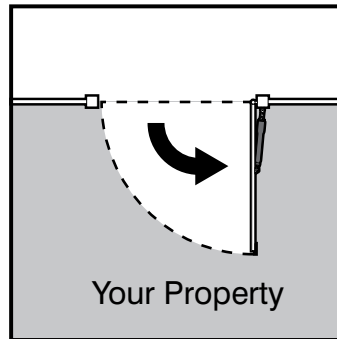

**Pull-To-Open**  
(arm retracts to open)

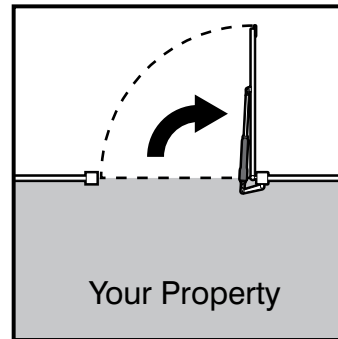

**Push-To-Open**  
(arm extends to open)

## 3. Prepare the Gates

- Gates must be plumb, level, and swing freely on their hinges.
- Wheels must **NOT** be attached to the gates.
- The gates must move throughout their arcs **without binding or dragging on the ground**.
- Note that gates **over 250 lb. should have ball bearing hinges** with grease fittings.
- The gate post should be secured in the ground with concrete so it will minimize twist or flex when the opener is activated.
- The addition of a **horizontal or vertical cross member** (if one is not already in place) to provide a stable area for mounting the gate bracket is also important.
- Trench the driveway in order to lay PVC conduit for the second opener power cable (see illustration on page 6).

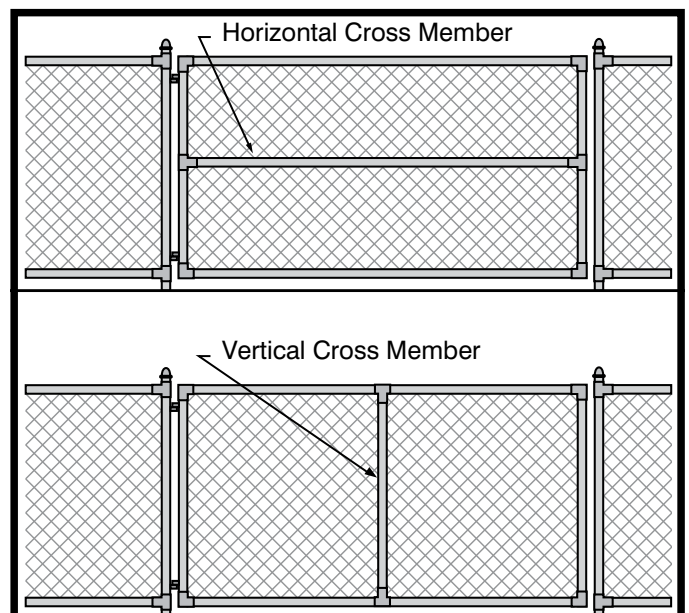
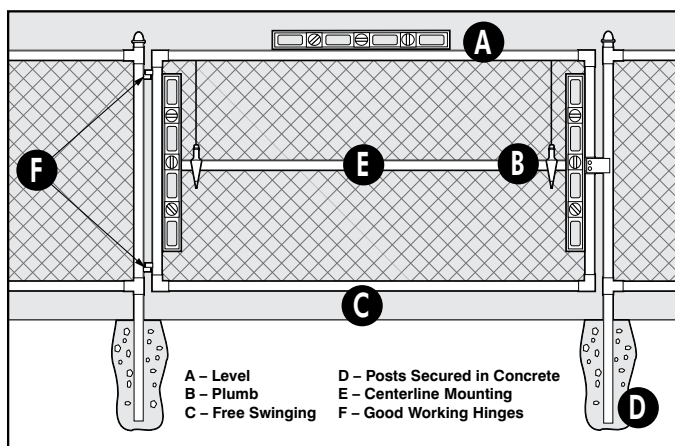

# Parts List – Opener and Mounting Hardware

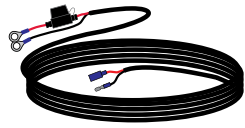

Battery Wire Harness (1)

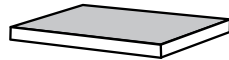

Installation DVD (1)



Warning Signs (4)



Control Box (1)

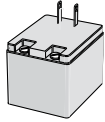

Transformer (1)  
RB502



GTO Transmitter (1)  
FM135

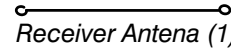

Receiver Antenna (1)

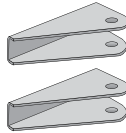

Gate Bracket (2)

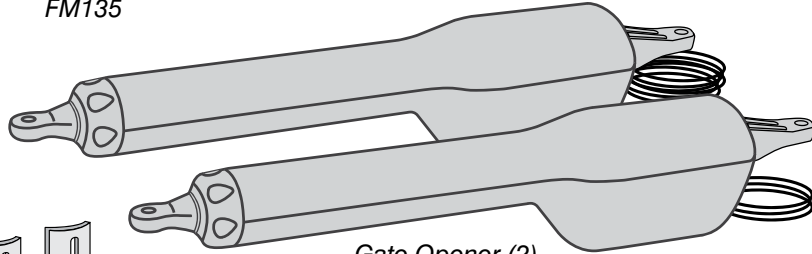

Gate Opener (2)

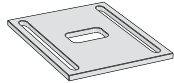

Closed Position Stop Plate (2)

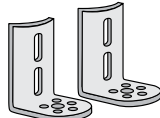

Post Bracket (2)

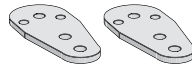

Post Pivot Bracket (2)



Customer Support Card (1)

## Hardware Bag Contents

8" Nylon Cable Tie (14)

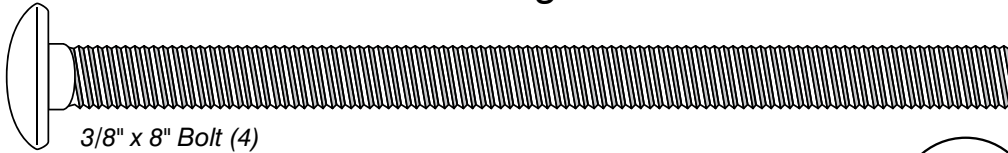

3/8" x 8" Bolt (4)

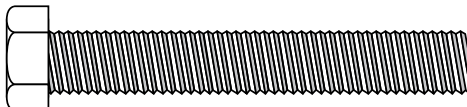

3/8" x 2-3/4" Bolt (4)

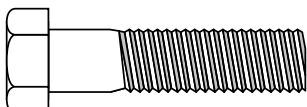

3/8" x 1-1/2" Bolt (2)

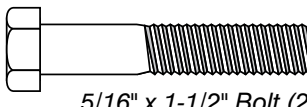

5/16" x 1-1/2" Bolt (2)

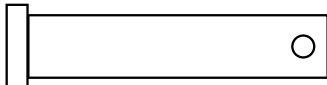

3/8" x 1-1/2" Clevis Pin (4)

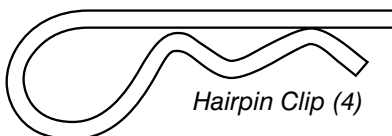

Hairpin Clip (4)

3/8" Washer (12)

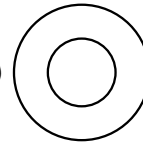

5/16" Washer (2)

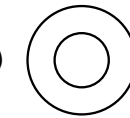

3/8" Lock Nut (10)

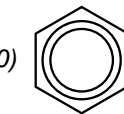

5/16" Lock Nut (2)



3/8" Bushings (2)



2" Mounting Screw (6)

# Tools and Materials

## Tools Needed:

- Power Drill
- Open End Wrenches — 1/2" and 9/16"
- Adjustable Wrench
- 3/8" Drill Bit
- Hacksaw or Heavy Duty Bolt Cutters
- Small Flat Bladed Screwdriver
- Large Phillips Screwdriver
- Tape Measure
- Level
- Wire Strippers
- C-Clamps — small, medium, and large
- Center Punch
- Hammer (for center punch)
- Extra person will be helpful

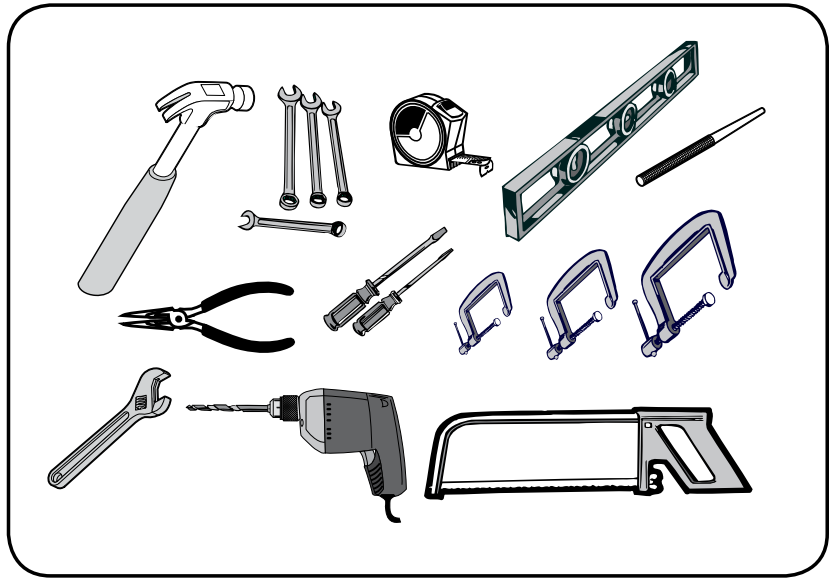

---

## Materials You May Need for the Installation:

These items are **NOT included** with the gate opener kit. Some of these items can be purchased or special ordered through Tractor Supply Co. Please see page 26 or [www.mightymule.com](http://www.mightymule.com).

- 12 VDC automotive/lawn tractor battery **is required** to power the opener. (Page 2)
- Low voltage wire [RB509] will be needed to run from the transformer to the opener control board; length depends upon the distance between the transformer power supply and the control box. (Page 13 & 26)
- If your gate is more than 1000' away from an AC power source you will need to use at least one 10 watt Solar Panel [FM123] to charge the 12 Volt battery. (Page 2 & 26)
- PVC conduit for protecting in ground wiring. (Page 6)
- Push-To-Open Brackets [FM148] are required if gates open out from property. Page 3 & 26)
- Materials to reinforce thin walled tube or panel gates. (Page 7)
- Depending on the type of gate, a horizontal cross member or mounting plate may be needed to mount the front of the opener and gate bracket to the gate. (Page 3 & 7)
- Some installations may require muffler clamps for the gate bracket. (Page 7)
- (2)16 AWG crimp on fork lugs (Page 15)
- Surge protection for transformer. (Page 16)
- Weather proof outlet is required if transformer is plugged into outside outlet. (Page 16)
- Some types of installations require U-Bolts for closed position stop plate. (Page 11)
- A low profile ground stop is required for dual gates when using the Mighty Mule gate lock. (Page 11)

# Installation Overview for Pull-To-Open Gates

PUSH-TO-OPEN installation instructions begin on page 19.

Example of an installation on a chain link fence:

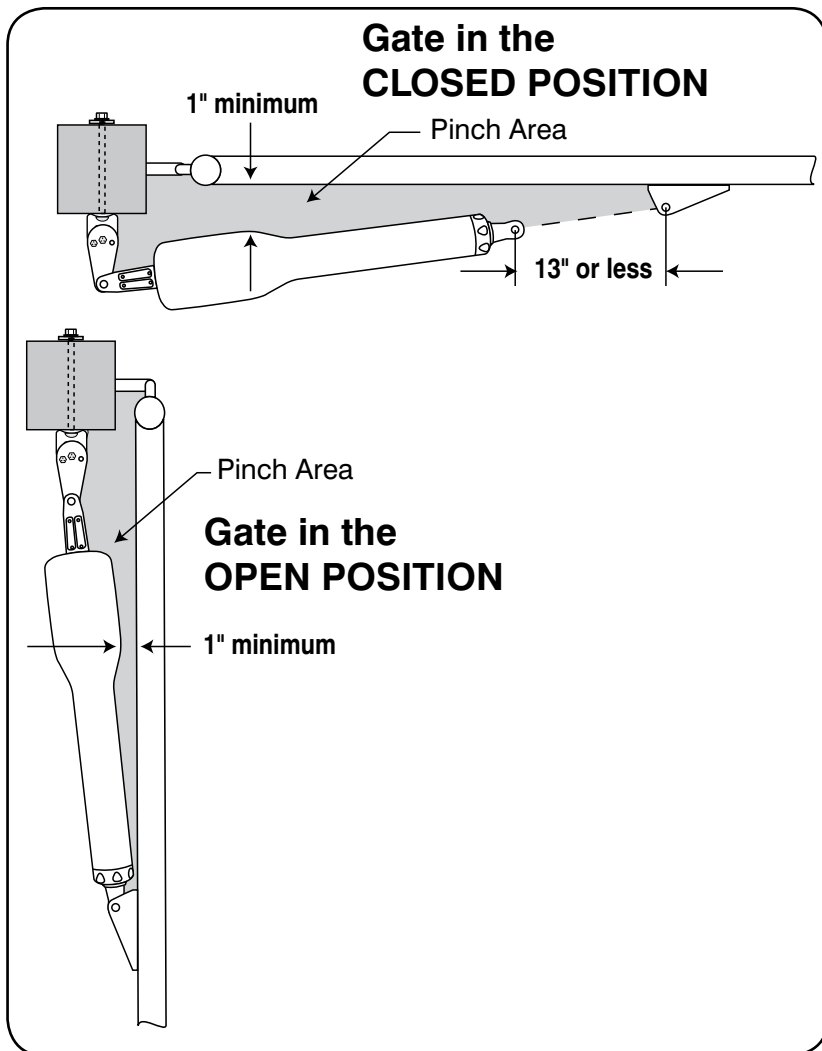
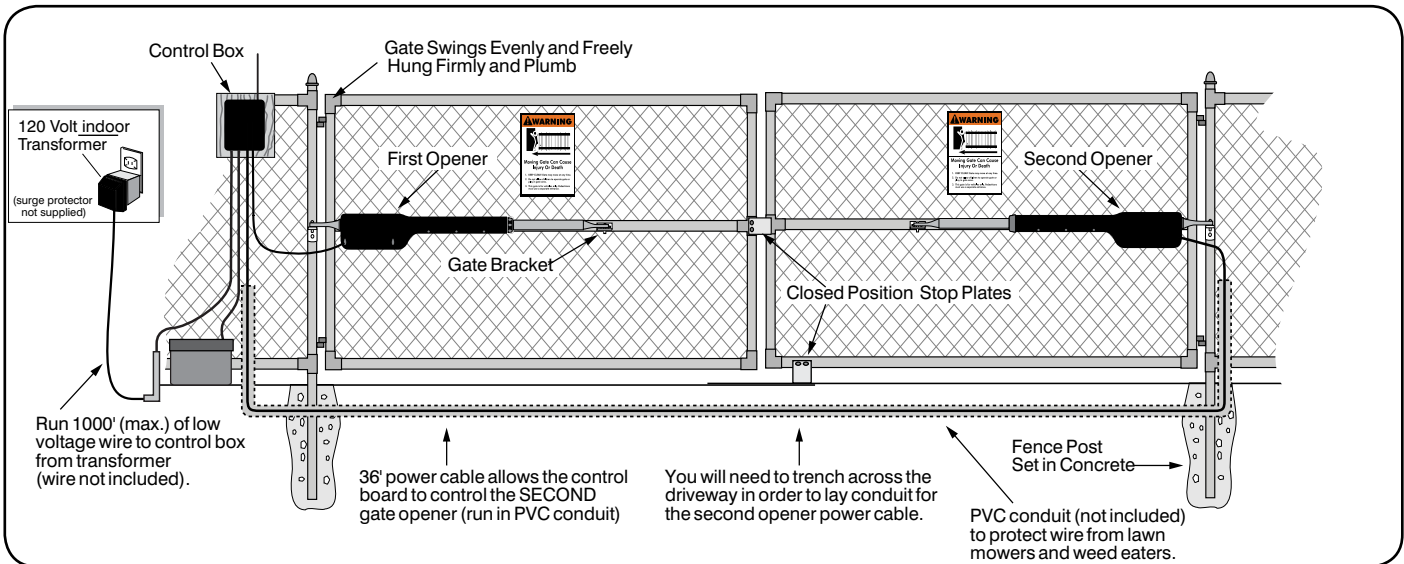

**IMPORTANT:** To achieve the most efficient leverage for the gate opener and ensure long trouble free service, the gate opener needs to be installed within the following parameters.

The diagram at left shows the optimum position for gate opener arm in relation to the gate in the open and closed positions. Be sure the position of the gate opener and brackets allows for 1" of clearance between the gate and the opener in both the open and closed position, at the same time maintaining a maximum distance of 13" from the end of the retracted opener arm to the gate bracket with the gate in the closed position.

If the gate post is larger than 6" the Post Pivot Bracket can be removed and the center hole of the Post Bracket can be the mounting point for the gate opener.

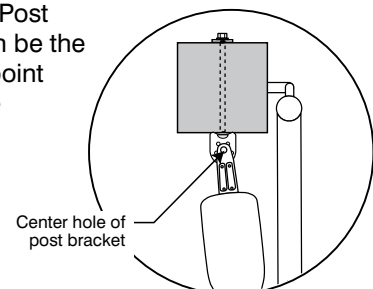



# Installation of the FIRST Gate Opener

**IMPORTANT:** Determine which side of the driveway you will mount the control box. From this point on, the gate and gate opener on the same side as the control box will be referred to as the **FIRST** gate and gate opener. The gate and gate opener on the opposite side of the driveway from the control box will be referred to as the **SECOND** gate and gate opener.

We recommend you position the opener near the **centerline** of the gate to keep the gate from twisting and flexing and to avoid backsplash from rain water.

## The Post Bracket Assembly

The position of the post bracket assembly determines the leverage and efficiency of the opener. The post bracket assembly position also sets the clearance between the opener and the gate in the open and closed positions.

The post bracket works well for installations on round and square fence posts. Because the post bracket carries the entire thrust of the active opener, **bolts must completely penetrate the post.**

On wood posts, place a metal plate or washer (not supplied) between the nuts and the post to prevent the thrust of the opener from pulling the bolts and washers out of the wood.

The post pivot bracket may not be necessary on posts larger than 6" in diameter (see page 6). Fence posts smaller than 6" in diameter or 6" square should be made of metal instead of wood to remain stable while the opener is moving the gate.

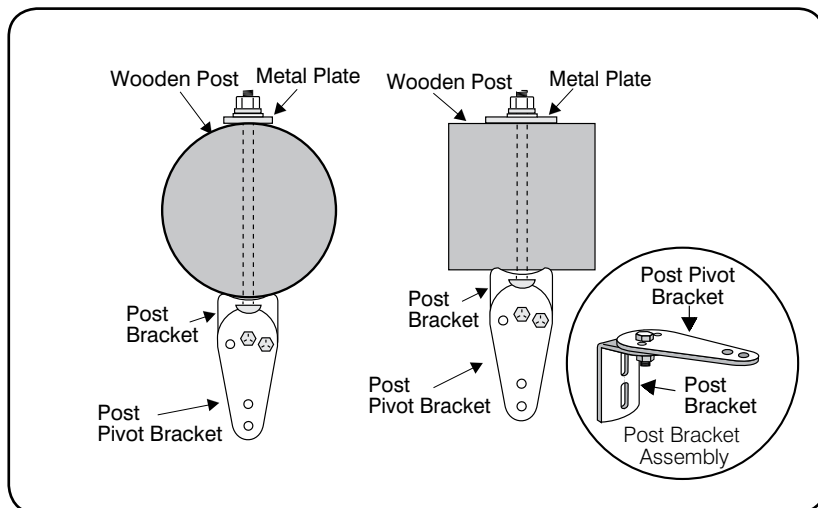

## Reinforcing Gates for the Gate Brackets

We **recommend** using a muffler clamp, wood, or metal, to reinforce thin-walled tube gates, or wood to reinforce panel gates as shown. These reinforcement methods will prevent damage to the opener and gate. Additional hardware may be needed depending on the installation.

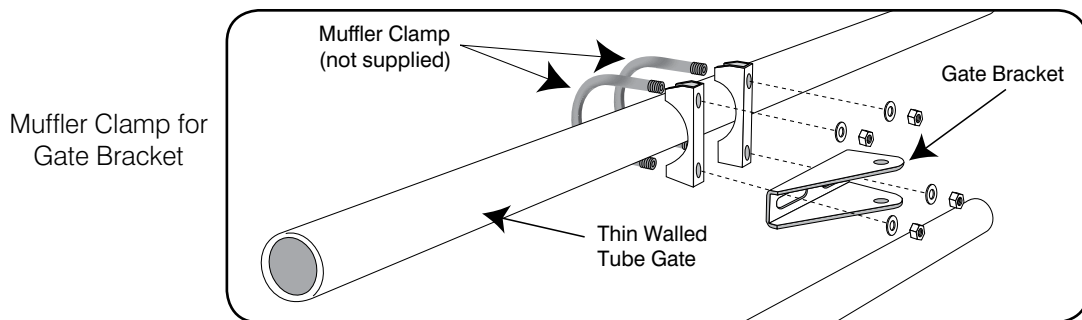

Muffler Clamp for Gate Bracket

Wood or Metal Reinforcement

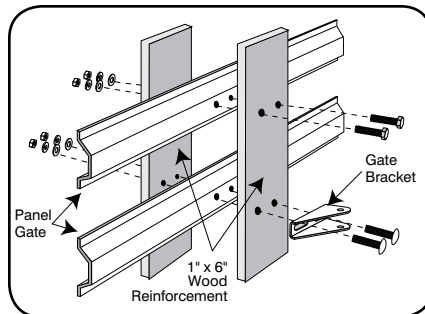
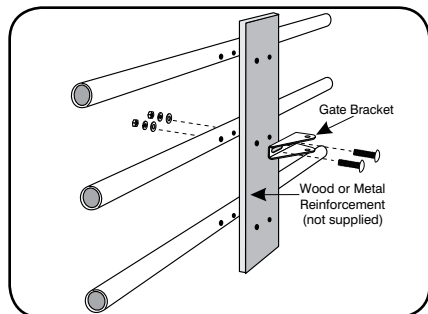

1" x 6" Wood Reinforcement

# Install Post Bracket Assembly and Gate Bracket

## Step 1

Insert the  $\frac{3}{8}$ " x  $1\frac{1}{2}$ " bolt through the center hole of the post brackets and post pivot bracket. Secure with a  $\frac{3}{8}$ " washer and  $\frac{3}{8}$ " lock nut. DO NOT *overtighten* the lock nut (the post pivot bracket will have to be adjusted later).

## Step 2

Attach post bracket assembly to the rear mount of the opener with a clevis pin and a  $\frac{3}{8}$ " washer. Secure the clevis pin with a hairpin clip.

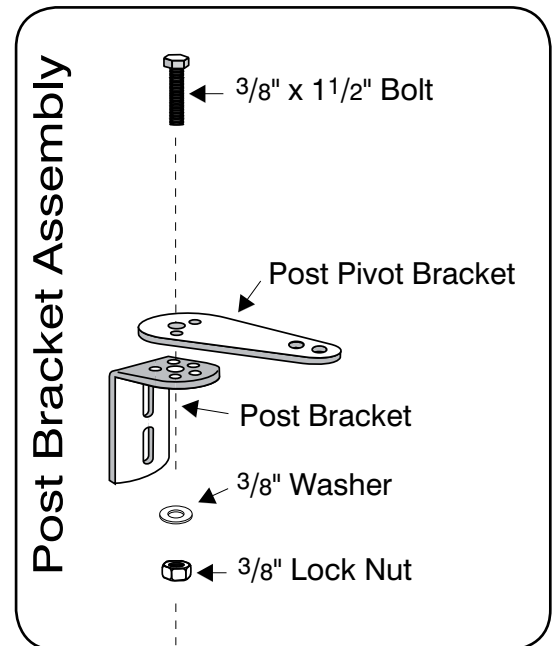
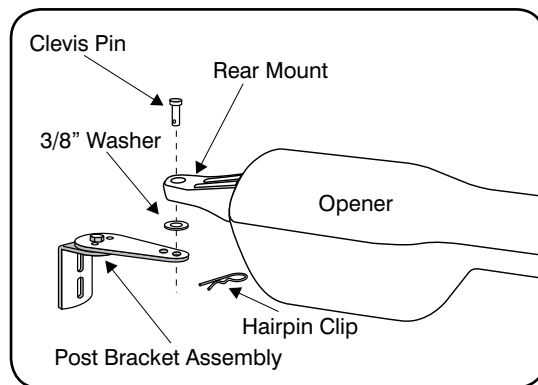

## Step 3

Attach gate bracket to the front mount of the opener with a clevis pin and a  $\frac{3}{8}$ " bushing. Secure the clevis pin with a hairpin clip.

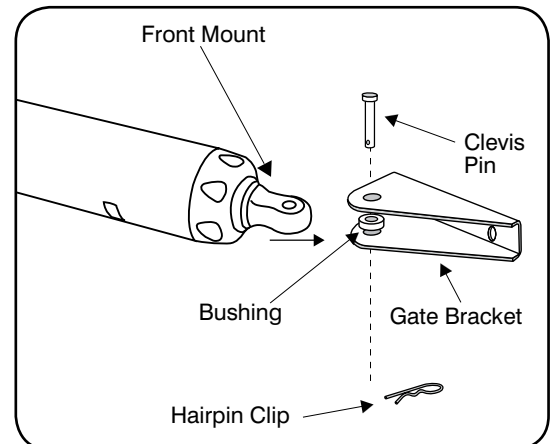

## Step 4

With the gate in the **fully open position and the opener arm fully retracted**, adjust the post bracket assembly and gate bracket until the opener is level. While holding the opener level, use C-clamps to temporarily secure the post bracket assembly and gate bracket to the post and gate.

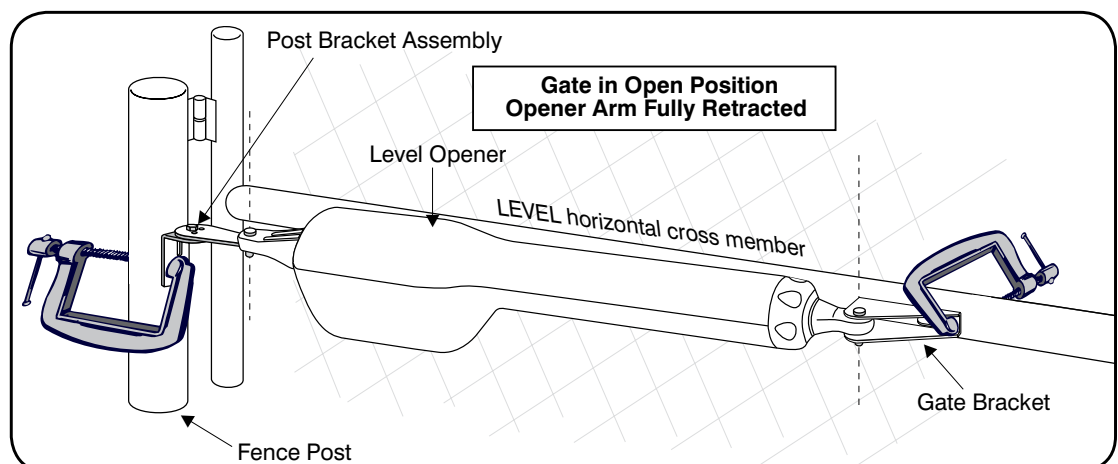

### Step 5

Be sure the position of the gate opener and brackets allows for 1" of clearance between the gate and the opener in both the open and closed position, while at the same time maintaining a maximum distance of 13" from the end of the retracted opener arm to the gate bracket with the gate in the **closed** position. This mounting position will give the opener the most efficient leverage point for operation and provides the least possible pinch area

### Step 6

After verifying that you have the best position for the post pivot bracket in the open position, insert the 5/16" x 1 1/2" bolt through the aligned holes of the post bracket and post pivot bracket to hold it in place. Remove the clevis pin from the front mount and **while supporting the gate opener**, swing the gate and gate opener to the **closed** position. Again, check the clearance and be sure that the gate opener is not binding at the post pivot bracket.

If you don't have the required clearance, or if the gate opener is binding on the post pivot bracket, remove the 5/16" x 1 1/2" bolt and readjust the post pivot bracket.

TIP: Turn the post pivot bracket over for more hole alignment options. You can also move the entire post bracket assembly to different positions on the post.

### Step 7

When the post bracket assembly is in the optimum position, reattach the opener to the gate bracket (gate in the open position); recheck the gate opener level; make sure the brackets are clamped securely.

### Step 8

Mark reference points for bolt holes on the post through middle of post bracket assembly slots. Mark reference points for bolt holes on the gate cross member through middle of gate bracket slots. After marking your reference points, remove the opener and brackets from the fence and gate.

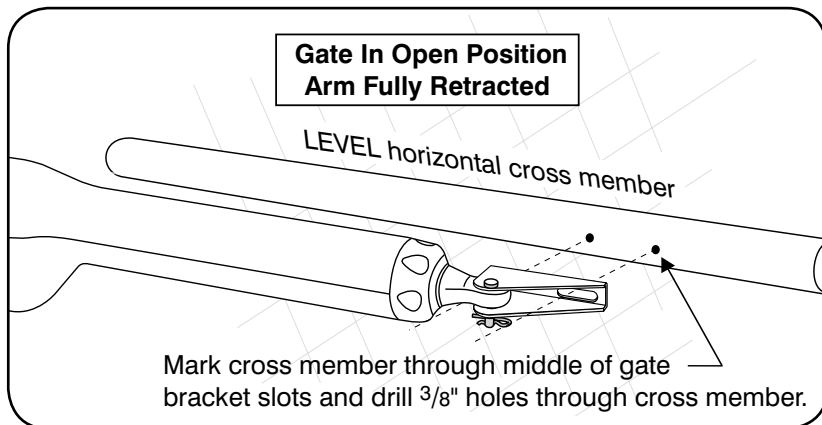
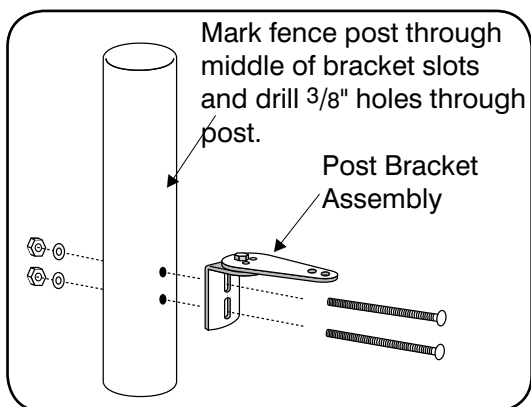
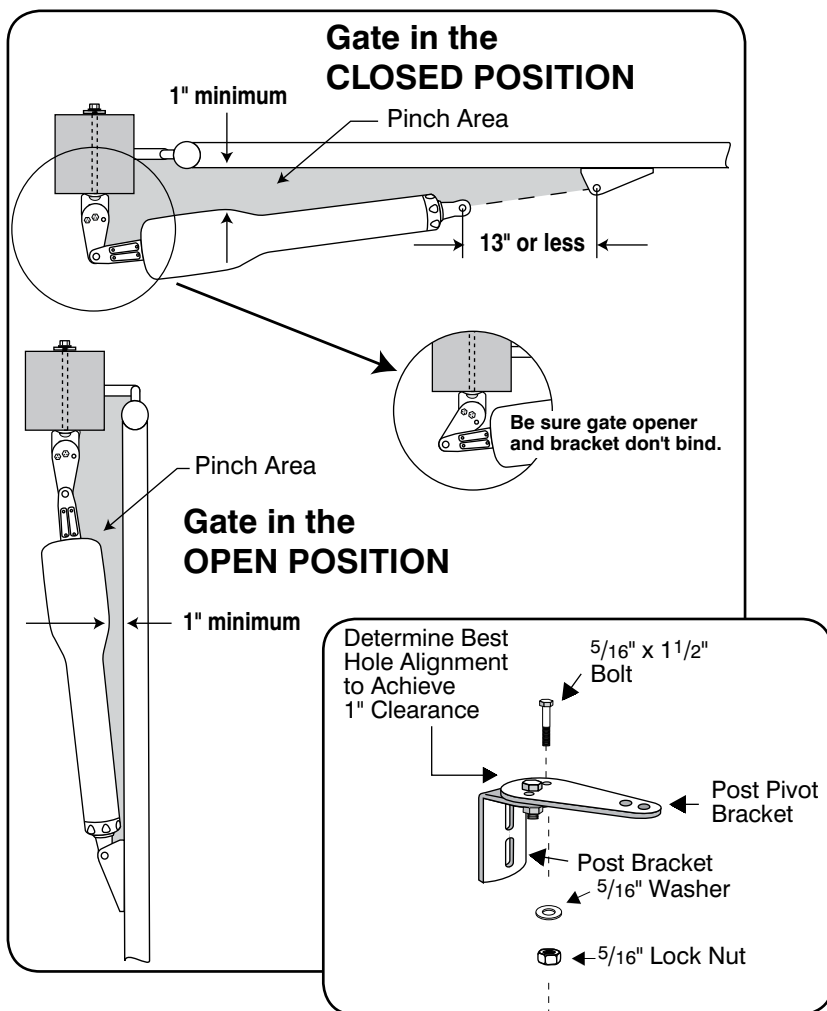

## Step 9

Drill  $\frac{3}{8}$ " holes through post as marked. Fasten post bracket assembly to the fence post using two  $\frac{3}{8}$ " x 8" bolts, washers and lock nuts. **You must use bolts that completely penetrate the post.**

## Step 10

Drill  $\frac{3}{8}$ " holes through the gate cross member as marked. Mount gate bracket using two  $\frac{3}{8}$ " x 2  $\frac{3}{4}$ " bolts, washers, and lock nuts.

NOTE: **After** the gate opener installation is **complete** and operation of **the opener system has been tested**, you should remove excess bolt length extending beyond the tightened nuts with a hacksaw or bolt cutters.

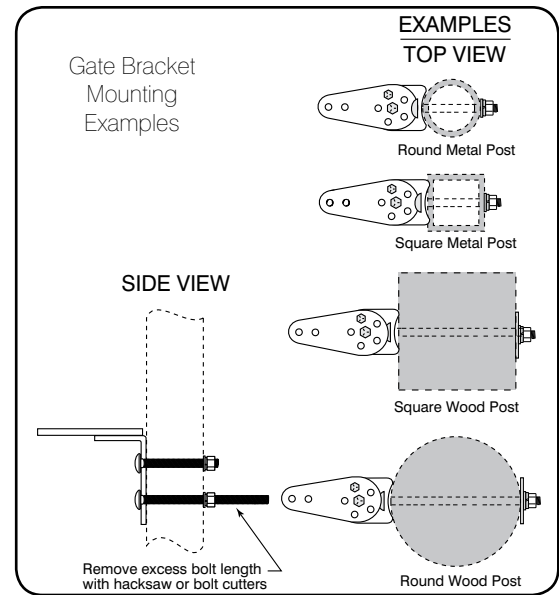

Gate Bracket Mounting Examples

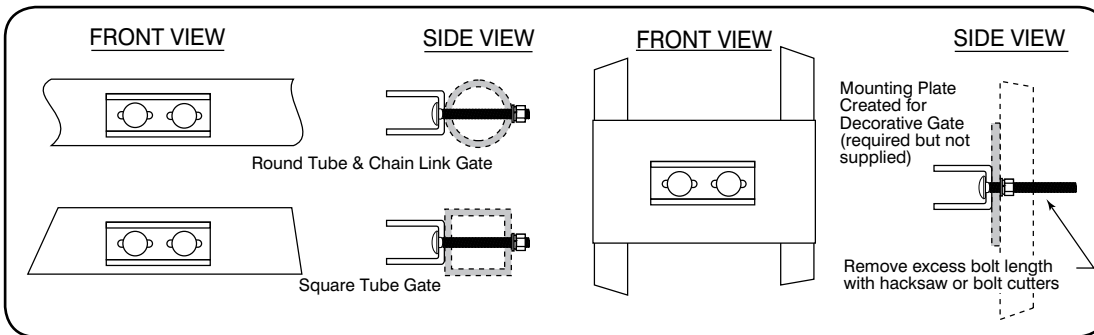

## Attach Opener Arm

### Step 1

Attach the opener to the securely bolted post bracket assembly and gate bracket using clevis pins, bushings, and hairpin clips, or optional Pin Lock [FM133] (page 26). Verify that the opener is level and adjust the post bracket assembly, if necessary.

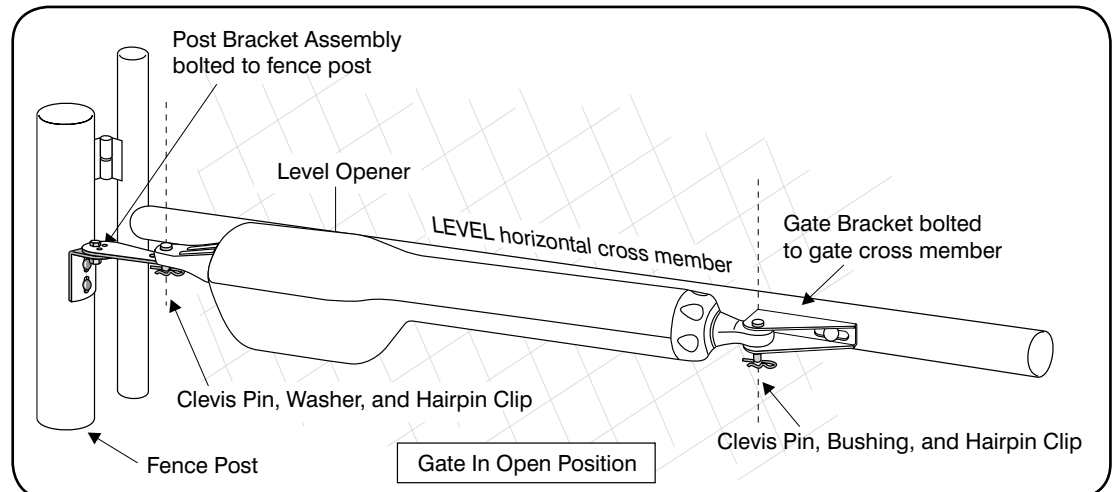

### Step 2

Install the SECOND gate opener and hardware on the second gate following the same procedures as the FIRST gate opener and hardware ("Installing Post Bracket Assembly and Gate Bracket" Steps 1–10).

NOTE: The power cable for the Second Opener should be run in PVC conduit under the driveway to protect it from damage due to lawnmowers, heavy equipment, etc. (See illustration on page 6.) NEVER SPLICE opener arm power cables. This will cause performance problems and may damage the opener.

# Install the Closed Position Stop Plates

The closed position stop plate is attached to the FIRST gate to help stabilize the gate leaf in the closed position. An optional low profile ground stop, when used with the closed position stop plate, provides a secure point for the SECOND gate to close against.

To further enhance the stability and security of your gate, install a Mighty Mule Automatic Gate Lock [FM143] page 26). If you will be using the Mighty Mule Gate Lock with your gate opener system, the closed position ground stop is *required*.

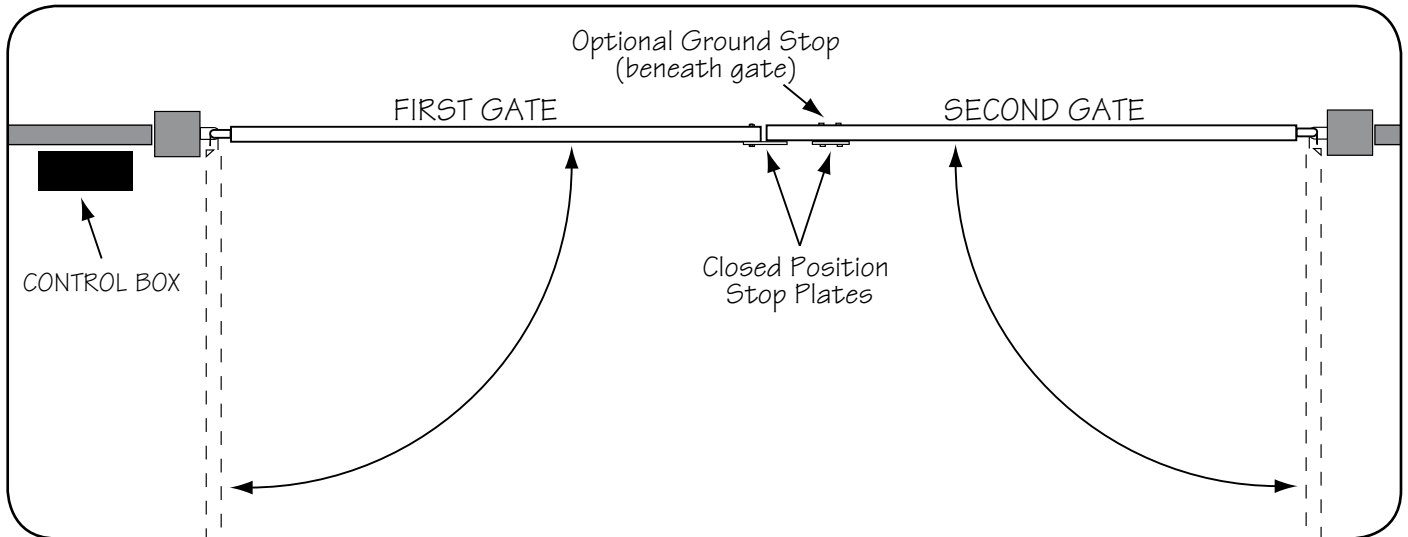

**For Pull-to-Open systems, install the closed position stop plates on the *inside* of the gates. For Push-to-Open systems, install the closed position stop plates on the *outside* of the gates.**

## Step 1

Detach the gate opener arms from the gates and move the gates to the closed position.

## Step 2

Using appropriate hardware for your type of gate (U-bolts for tube or chain link; screw or bolts for wood or metal) attach the closed position stop plate (horizontally) about mid-height on the FIRST gate frame. Do not tighten it completely at this time. Slide the stop plate toward the frame of the SECOND gate leaf until they touch. Once you have moved the stop plate to the correct position, tighten its hardware completely.

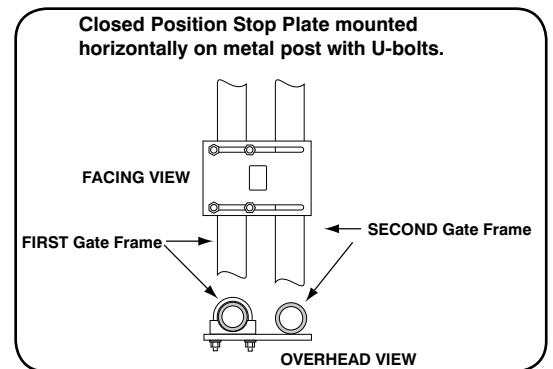

## Step 3

The low profile ground stop may be made of metal or concrete and should be firmly secured in the ground. The low profile ground stop should be installed beneath the SECOND gate, positioned near the leading edge.

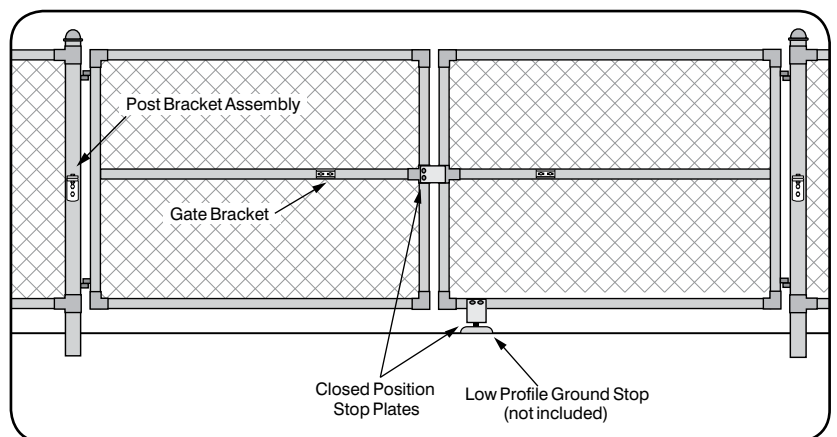

## Step 4

Using appropriate hardware for your type of gate, attach the vertical closed position stop plate to the **SECOND** gate frame at the point where it will come in contact with the low profile ground stop. Do not tighten it completely at this time. You must slide the closed position stop plate toward the low profile ground stop until they touch. Once you have moved the stop plate to the correct position, tighten its hardware completely.

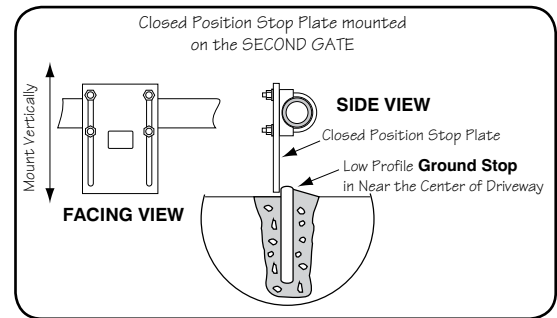

## Step 5

Return the gates to their open positions and reattach the gate openers to the gates.

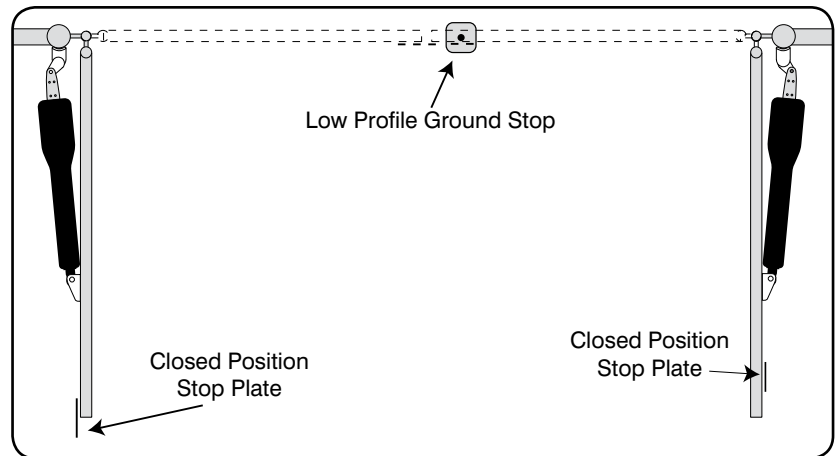

## Mount the Control Box

### Step 1

Mount the control box using the screws (provided) or another secure mounting method. The control box must be mounted at least 3 feet above the ground to protect it from rain splash, snow, etc., and at least 3 feet from an AC power source to prevent electrical interference.

### Step 2

Remove the control box cover by removing the four (4) screws.

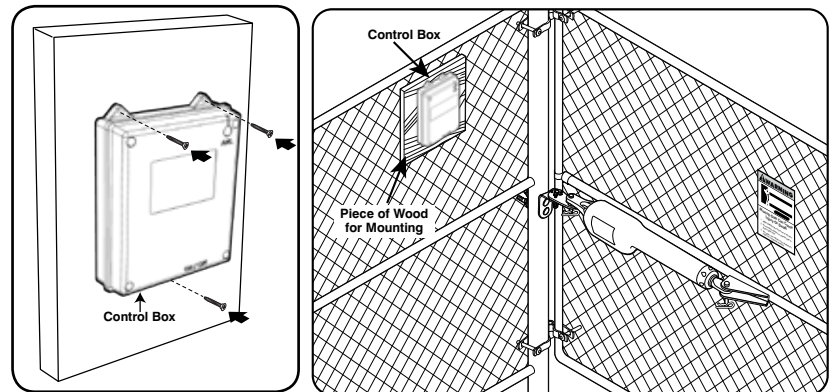

### Step 3

Attach antenna to control box cover. First, remove the Phillips screw (labeled ANT) from the control box cover. Place one end of the antenna coil over the antenna plug (antenna wire will fit into groove). Tighten the Phillips screw to secure antenna.

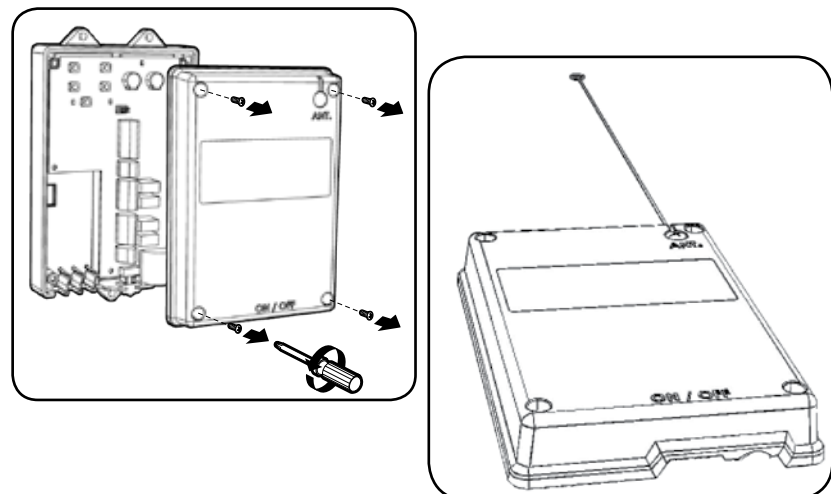

# Connect Opener Power Cables

## Step 1

Bring FIRST power cable into the control box through a strain relief slot, leaving enough wire to reach the FIRST OPR. terminal block.

Insert the individual power cable wires into appropriate terminals on the FIRST OPR. terminal block (white to WHT; green to GRN; red to RED; black to BLK). Tighten the set screws. A dab of petroleum jelly on each terminal will help prevent corrosion.

## Step 2

Pull the 36' second opener power cable through the PVC conduit and secure in the driveway slot/trench (see pages 6 and 14).

## Step 3

Insert the SECOND power cable into a strain relief slot. Bring power cable into the control box through a strain relief slot, leaving enough wire to reach the SECOND OPR. terminal block.

Insert the individual power cable wires into appropriate terminals on the SECOND OPR. terminal block (white to WHT; green to GRN; red to RED; black to BLK). Tighten the set screws. A dab of petroleum jelly on each terminal will help prevent corrosion.

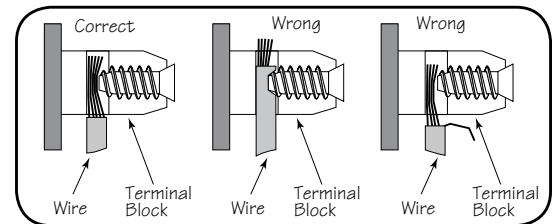
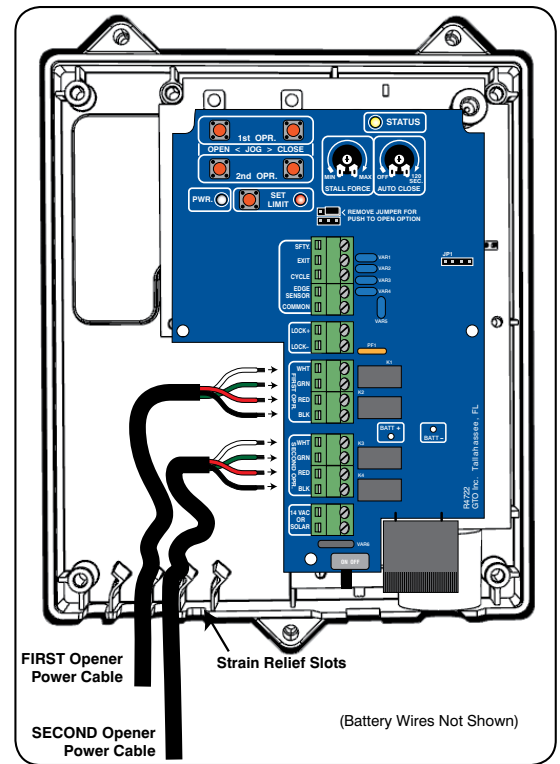

# Connect the Transformer (\*Solar Instructions on Page 21)

**NEVER USE TRANSFORMER AND SOLAR PANEL(S) AT THE SAME TIME!**

## IMPORTANT INFORMATION ABOUT LOW VOLTAGE WIRE:

- The only wire acceptable for use with GTO products is 16 gauge multi-stranded, low voltage, direct burial wire. This particular gauge enables the transformer to provide an adequate charge through the control board to the battery at distances up to 1000'.
- DO NOT use telephone wire or solid core wire. Unlike multi-stranded wire, these types of wire are inadequate for use with your gate opener system.
- NEVER splice wires together. Splicing permits corrosion and seriously degrades the wire's ability to carry an adequate current.

## Step 1

Make sure the power switch is OFF.

## Step 2

Select the electrical outlet where you will plug the transformer. Measure the distance from this outlet to the control box following the path where the wire will be laid. After you have measured how much wire is needed, cut the wire to the appropriate length (up to 1000').

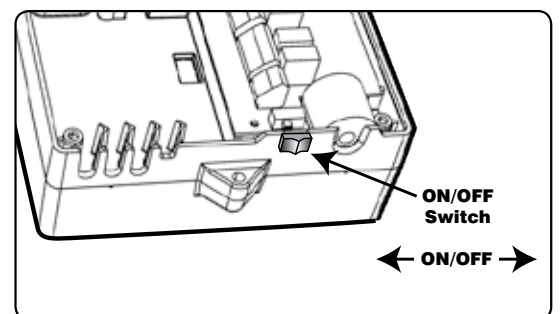

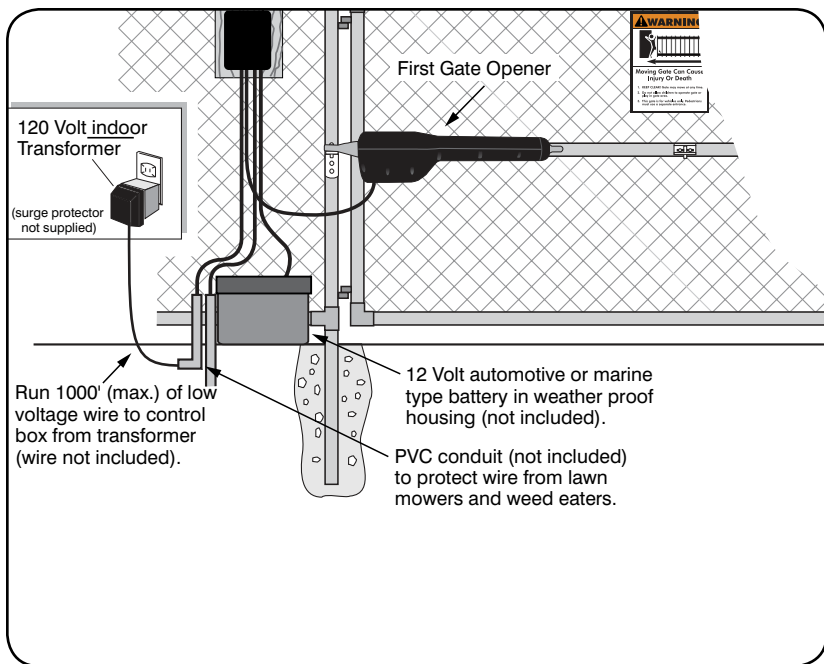

### Step 3

Lay the measured length of low voltage wire in a trench following a path from the selected electrical outlet to the control box. Wires coming up from the ground should be run through PVC conduit to protect them from lawn mower blades, weed eaters, and grazing animals. Be sure to bury the wire laid in the trench.

### Step 4

Bring enough wire up through the PVC conduit to reach the control board.

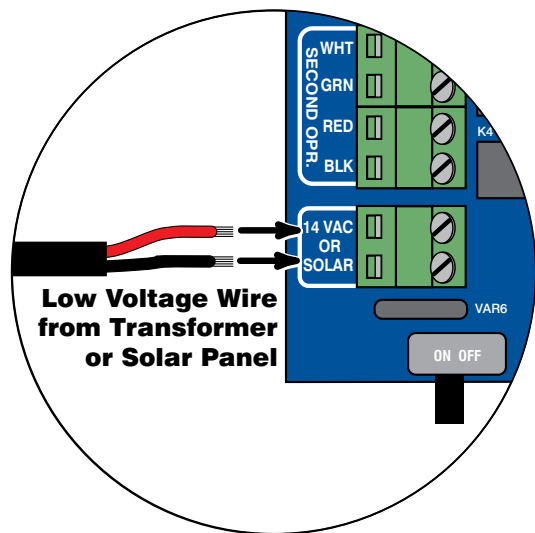
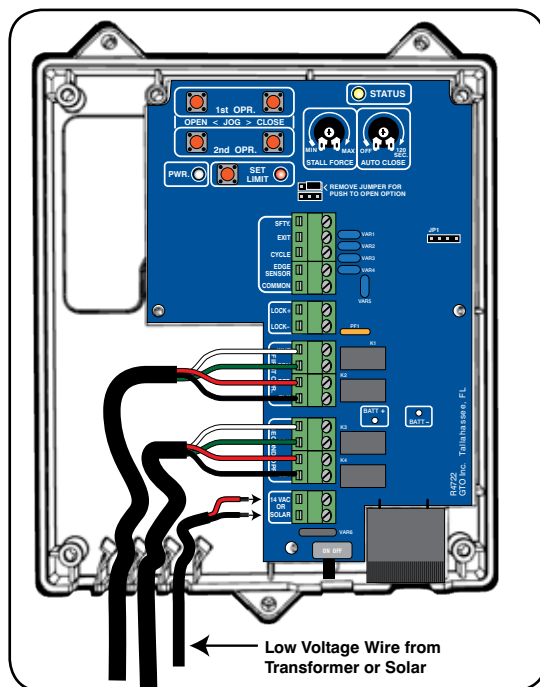

### Step 5

Strip 3/16" off the ends of the low voltage wire and twist tightly. Attach these ends to the 14VAC OR SOLAR terminals located on the terminal block). Be certain not to let the exposed wires touch each other!

Insert one transformer wire into a 14VAC OR SOLAR terminal. Insert the other transformer wire into the remaining 14VAC OR SOLAR terminal. The transformer wires can be connected to the 14VAC OR SOLAR terminals regardless of color/polarity.

Tighten set screws against exposed end of wires. A dab of household petroleum jelly on each terminal will help prevent corrosion.



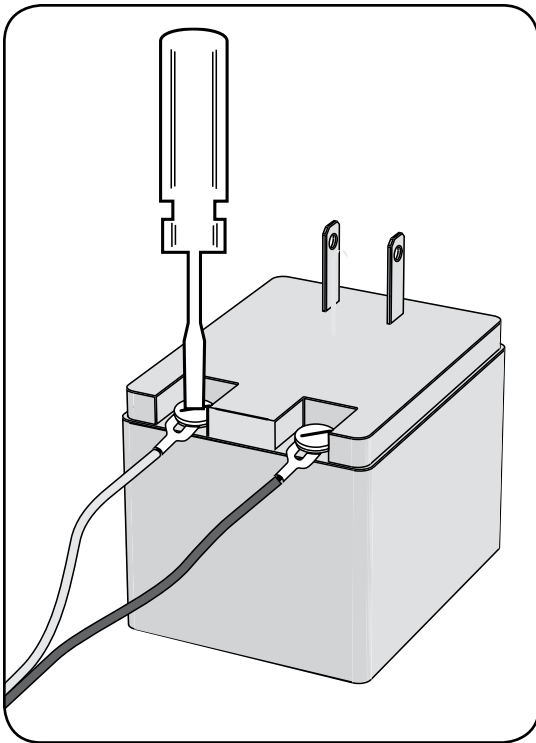

### Step 6

At the AC outlet, strip 1/2" of insulation from the ends of the low voltage wire. Attach these stripped ends to the transformer terminals. A dab of household petroleum jelly on each terminal will help prevent corrosion. We suggest adding crimp on fork lugs to the end of each wire before attaching it to the transformer.

**Make sure the exposed wires do not touch each other!**

## Connect Battery Harness to Control Board

### Step 1

Make sure control box is OFF. Locate the BATTERY wires from the CONTROL BOARD marked BATT + and BATT -.

### Step 2

Run the battery harness wires into the control box through a strain relief slot, leaving enough wire to reach the battery wire plugs.

### Step 3

Plug the BLACK battery harness wire into the BLACK wire (BATT - terminal), and the RED battery harness wire to the RED wire (BATT + terminal). Wire correctly; **reverse connection will damage control board.**

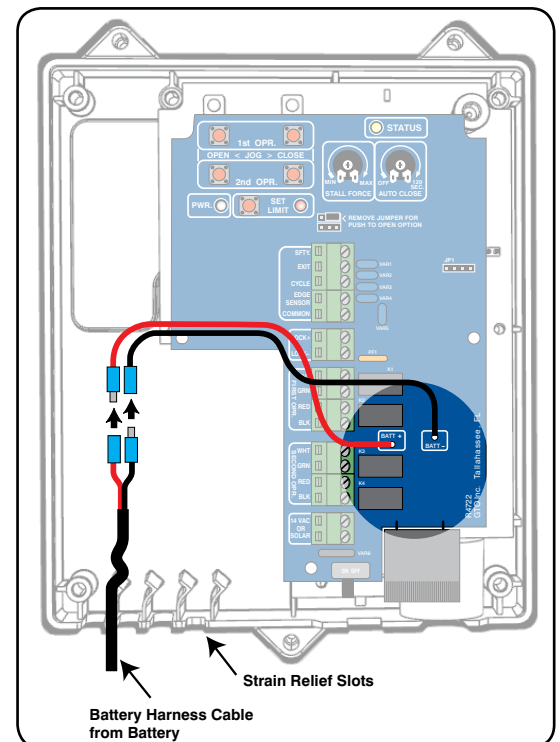

## Connect the Battery

### Step 1

Place the 12 Volt automotive/lawn tractor battery and its weatherproof case within 6 feet of where the control box is mounted.

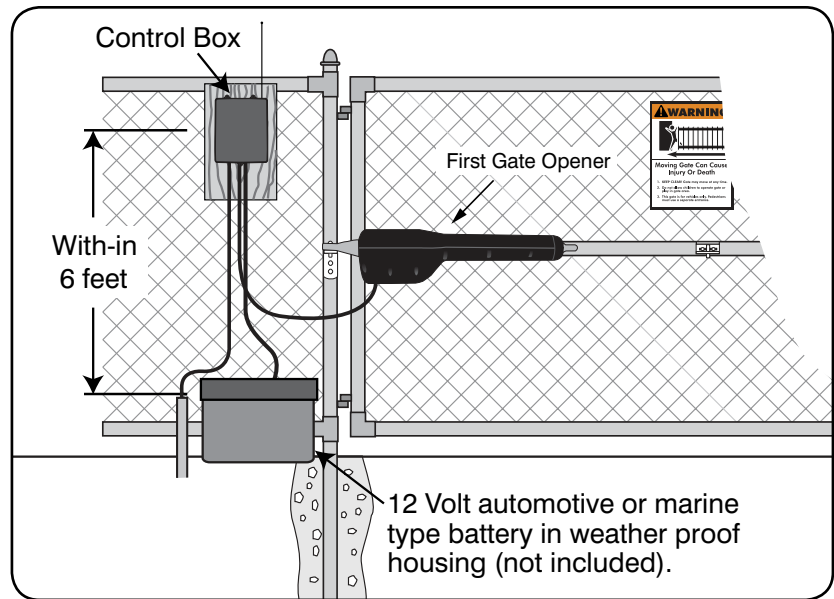
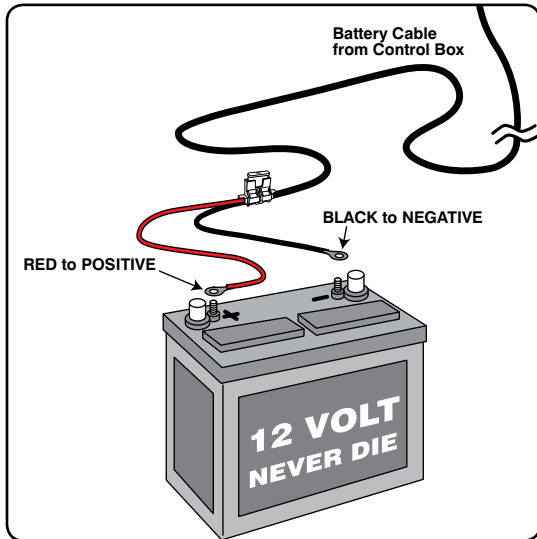

### Step 2

Attach the battery wires provided to the terminals of the battery. Take care to attach the BLACK wire to the NEGATIVE terminal and the RED wire to the POSITIVE terminal. **Reverse connection will cause damage to the control board.**

### Step 3

Plug the transformer into the electrical outlet. Use of a surge protector with the transformer is **strongly** recommended. If electrical outlet is located outdoors, outlet and transformer should be protected by a weatherproof cover.

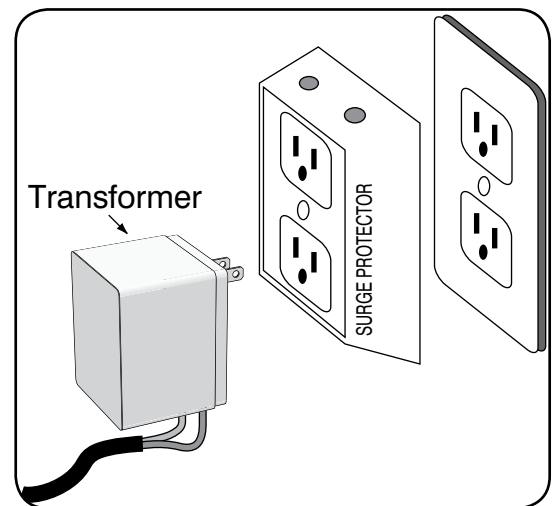

## Set the CLOSED Position Limit for PULL-TO-OPEN Installation

Your transmitter must be able to operate the gate. If not see, "Personalize Your Transmitter Setting on page 18.

Note: The OPEN limit is when the opener is fully retracted and the gate is in the full open position. The open limit setting can only be adjusted by moving the gate bracket. To achieve the optimum closed position, you must adjust the CLOSED limit setting:

### Step 1

Make sure the Control Box is ON and that the gate is in the OPEN POSITION (arms fully retracted).

### Step 2

Press and HOLD the 2nd Opener CLOSE button on the control board and be prepared to RELEASE the button when the gate reaches the desired closed position/limit. Use the JOG OPEN and CLOSE buttons to "fine tune" the gate position if necessary.

### Step 3

Press and HOLD the 1st Opener CLOSE button on the control board and be prepared to RELEASE the button when the gate reaches the desired closed position/limit. Use the JOG OPEN and CLOSE buttons to "fine tune" the gate position if necessary.

### Step 4

With the gates in in the desired closed positions PRESS and HOLD the SET LIMIT button until the alarm and RED Light come on. Then release the button.

NOTE: The opener must be extended more than 7 inches to set limits.

### Step 5

NOTE: When the control box cover is removed the receiver range is reduced to less than 5 feet.

Press the transmitter button once (within 5 feet of the control board) and allow the gates to fully open. The alarm will beep once when both gates reach the OPEN LIMIT. This indicates the limits for both arms are programmed in memory.

### Step 6

Press the transmitter button and allow the gates to fully close to verify that they stop at the desired positions. Repeat Steps 2-5 if correction is needed.

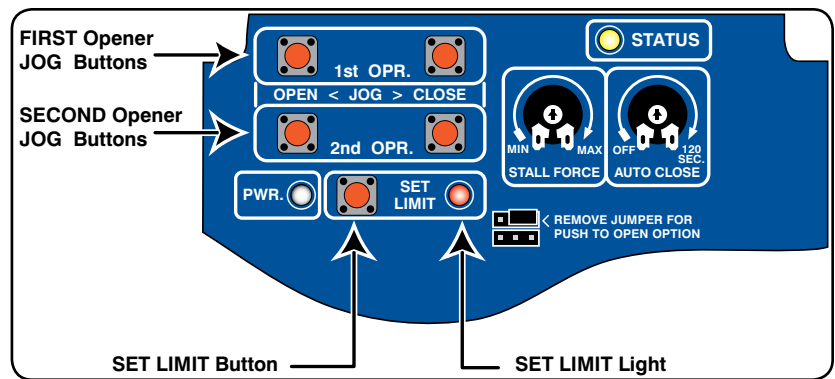

## Adjust the Stall Force Potentiometer Setting

The Stall Force potentiometer controls the the amount of force the opener will apply against an obstruction before it stops and reverses direction within two seconds.

**IMPORTANT:** The Stall Force setting **will need to be adjusted** to compensate for the weight and size of your gates. For safety reasons, use the lowest possible setting to operate the gate.

The Stall Force potentiometer on the control board operates like a volume control on a radio. Use a small flat blade screwdriver to turn the arrow in the center of the potentiometer. Adjust the sensitivity from the MINIMUM position just to the point where the gates operate smoothly without obstructing from their own weight or wind conditions.

NOTE: You may need to increase the stall force in cold weather due to increased resistance from gate hinges.

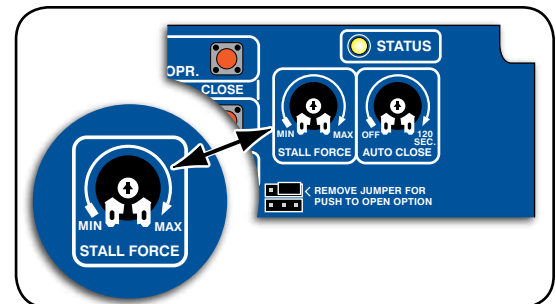

## Set Auto-Close Time

The Auto-Close determines how long the gate will remain open before it automatically closes. The factory setting is OFF. Use a small flat blade screwdriver, you can adjust the settings to OFF, or from 3 to 120 seconds.

NOTE: Auto-Close timer is disabled (gate will not automatically close) if gate is not at the fully open position.

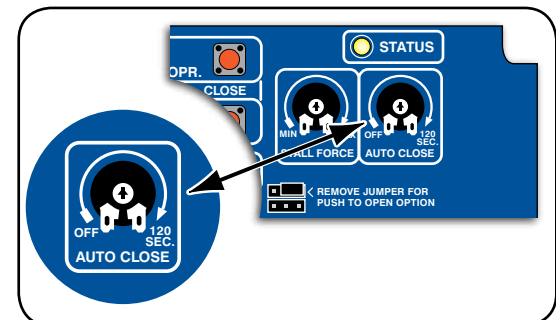

# Personalize Your Transmitter Setting

All GTO transmitters have a standard setting and are ready to operate your Mighty Mule Gate Opener. For your safety and security, we strongly recommend that you replace the factory setting with your own personal setting.

NOTE: If you have multiple transmitters, you should adjust all of them at this time.

## Step 1

Use a small phillips head screw driver to remove the transmitter cover.

## Step 2.

Set the transmitter DIP switches using a small screwdriver. There are nine (9) transmitter DIP switches; each can be placed in three different positions (+, 0, -). DO NOT set all the switches in the same position, such as all +, all 0, or all -. Once the DIP switches have been reset, replace and close the access cover.

WARNING: No other adjustments should be made inside the transmitter.

## Step 3.

Program the new setting in the control board memory.

- A. Slide the control box ON/OFF switch to the OFF position.
- B. Press and hold the transmitter button while sliding the ON/OFF switch to the ON position.
- C. Continue to hold the transmitter button until the alarm sounds (3-5 seconds).
- D. Release the transmitter button. The new transmitter setting is now programmed.
- E. Verify that the transmitter operates the gate.

NOTE: It is NOT necessary to remove the cover of the control box to program the new transmitter code, but when the control box cover is removed the receiver range is reduced to less than 5 feet.

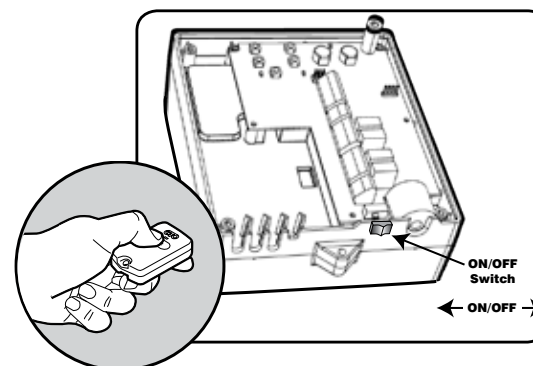
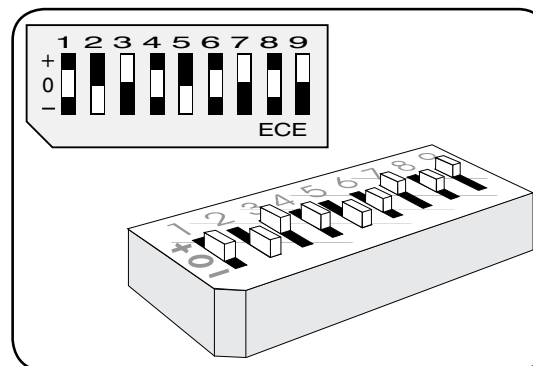
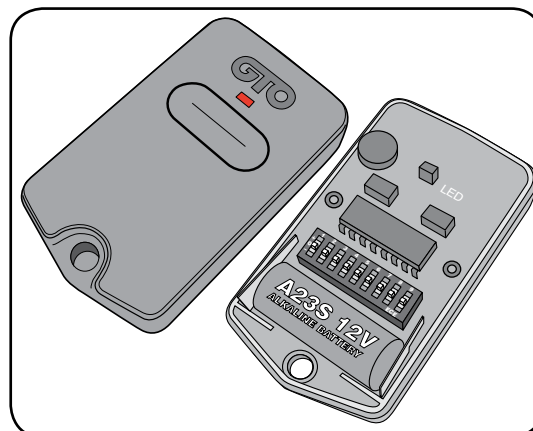

FCC WARNING: Changes or modifications to this unit not expressly approved by the party responsible for compliance could void the user's authority to operate the equipment. In accordance with FCC Part 15, Section 15.21, the manufacturer is not responsible for any radio or TV interference caused by unauthorized modifications to this equipment. Such modifications could VOID the user authority to operate the equipment.

NOTE: This equipment has been tested and found to comply with the limits for a Class B digital device, pursuant to Part 15 of the FCC Rules. These limits are designed to provide reasonable protection against harmful interference in a residential installation. This equipment generates, uses and can radiate radio frequency energy and, if not installed and used in accordance with the instructions, may cause harmful interference to radio communications. The external solid wire antenna (10") was used during FCC testing. Substitutes should not be used.

However, there is no guarantee that interference will not occur in particular installations. If this equipment does cause harmful interference to radio or television reception, which can be determined by turning the equipment off and on, the user is encouraged to try to correct the interference by one or more of the following measures: • Increase the separation between the equipment and the receiver. • Connect the equipment into an outlet on a circuit different from that which the receiver is connected. • Consult the dealer or an experienced radio/TV technician for help.

# Push-To-Open Installation Instructions

**PUSH-TO-OPEN** gates open out from the property (opener arms *extend* to open). Push-To-Open Brackets are required for this type of installation, one for each gate [FM148] page 26). In a Push-To-Open installation, the opener is installed while the gate is **in the closed position and the opener fully retracted**.

**Swinging gates MUST NEVER open into public access areas!**

Step 1: Read "Installation of the Gate Opener" on page 7.

Step 2: Determining The Mounting Position of The Post Bracket Assembly

- A. Insert the  $\frac{3}{8}$ " x  $1\frac{1}{2}$ " bolt through the center hole of the post brackets and post pivot bracket. Secure with a  $\frac{3}{8}$ " washer and  $\frac{3}{8}$ " lock nut. **DO NOT overtighten** the lock nut (the post pivot bracket will have to be adjusted later). Attach post bracket assembly to the rear mount of the opener with a clevis pin and a  $\frac{3}{8}$ " washer. Secure the clevis pin with a hairpin clip. Attach gate bracket to the front mount of the opener with a clevis pin and a  $\frac{3}{8}$ " bushing. Secure the clevis pin with a hairpin clip.
- B. With the gate in the closed position (up to  $110^\circ$  from its open position), and the opener fully retracted, adjust the post bracket assembly and gate bracket until the opener is level. While holding the opener level, use C-clamps to temporarily keep the post bracket assembly and gate bracket in their respective positions on the fence post and gate.

**IMPORTANT:** Be sure the position of the gate opener and brackets allows for 1" of clearance between the gate and the opener in both the open and closed position, while at the same time maintaining a maximum distance of 13" from the end of the opener arm to the gate bracket with the gate in the *open* position. This mounting position will give the opener the most efficient leverage point for operation and provides the least possible pinch area.

- C. After verifying that you have the best position for the post pivot bracket in the closed position, insert the  $\frac{5}{16}$ " x  $1\frac{1}{2}$ " bolt through the aligned holes of the post bracket and post pivot bracket to hold it in place. Remove the clevis pin from the front mount and **while supporting the gate opener**, swing the gate and gate opener to the *open* position. Again, check the clearance and be sure that the gate opener is not binding at the post pivot bracket.

**IMPORTANT:** If you don't have the required clearance, or if the gate opener is binding, remove the  $\frac{5}{16}$ " x  $1\frac{1}{2}$ " bolt and readjust the post pivot bracket. TIP: Turn the post pivot bracket over for more hole alignment options.

- D. When the post pivot bracket assembly is in the optimum position, reattach the opener to the gate bracket (gate in the closed position); recheck the gate opener level; make sure the brackets are clamped securely. Mark reference points for bolt holes on the post through middle of post bracket slots. Mark reference points for bolt holes on the gate cross member through middle of gate bracket slots. After marking your reference points, remove the opener and brackets from the post and gate.

- E. Drill  $\frac{3}{8}$ " holes through post as marked. Fasten post bracket assembly to the post using two  $\frac{3}{8}$ " x 8" bolts, washers and lock nuts. **You must use bolts that completely penetrate the post.** Drill  $\frac{3}{8}$ " holes through the gate cross member as marked. Mount gate bracket using two  $\frac{3}{8}$ " x  $2\frac{3}{4}$ " bolts, washers, and lock nuts.

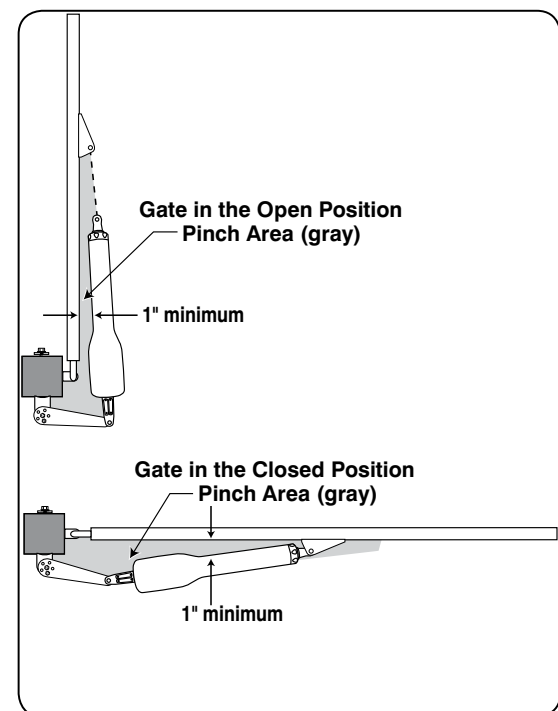
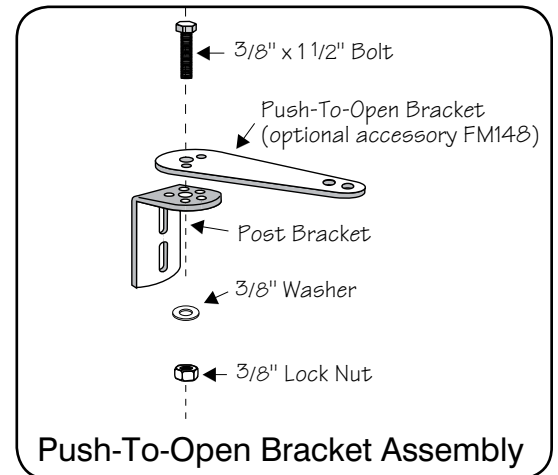

- Step 3: Attach Opener Arm (page 10)
- Step 4: Install Closed Position Stop Plates (page 11)
- Step 5: Mount the Control Box (page 12)
- Step 6: Connect Opener Power Cables (page 13)
- Step 7: Connect the Transformer (page 13) OR Solar Charger (page 21)
- Step 8: Connect Battery Harness (page 15)
- Step 9: Connect Battery (page 16)
- Step 10: Remove Push-To-Open Jumper

- A. Make sure the control box power switch is OFF.
- B. Use small pliers to move the JUMPER for PUSH-TO-OPEN applications.
- C. Turn power switch ON. The control board is now configured to push the gate open. (Keep the jumper, as it is necessary if there is ever a need to convert the opener for Pull-To-Open).

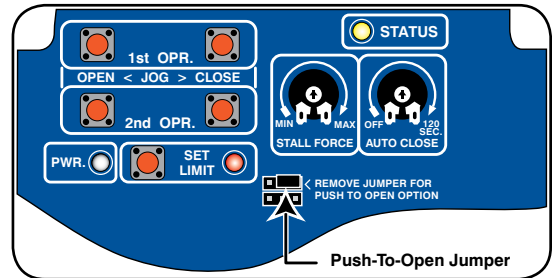

**Step 11: Set the Open Position Limit (Push-to-Open)**

Note: Must have a transmitter that operates the gate. If not see Personalize Your Transmitter Setting on page 18.

The CLOSED limit is when the opener is fully retracted and the gate is in the closed position. The closed limit setting can only be adjusted by moving the gate bracket. To achieve the optimum open position, you must adjust the OPEN Limit setting:

- A. If not already ON slide the ON/OFF switch on the Control Box to the ON position and make sure the arms are in the CLOSED POSITION (fully retracted).
- B. Press and HOLD the FIRST Opener OPEN button on the control board and be prepared to RELEASE the button when the gates reached the desired open position/limit. Use the JOG OPEN and CLOSE buttons to "fine tune" the gate position if necessary.
- C. Press and HOLD the SECOND Opener OPEN button on the control board and be prepared to RELEASE the button when the gates reached the desired open position/limit. Use the JOG OPEN and CLOSE buttons to "fine tune" the gate position if necessary.
- D. NOTE: The opener arms must be extended more than 7 inches to set limits. With the gates in in the desired open positions PRESS and HOLD the SET LIMIT button until the alarm and RED Light come on. Then release the button.
- E. NOTE: When the control box cover is removed the receiver range is reduced to less than 5 feet. Press the transmitter button once and allow the gates to fully close. The alarm will beep once when both gates reach the CLOSED LIMIT. This indicates the LIMITS for both arms are learned and stored in memory
- F. Press the transmitter button and allow the gates to fully open to verify that they stop at the desired positions. Repeat Steps B – E if correction is needed.

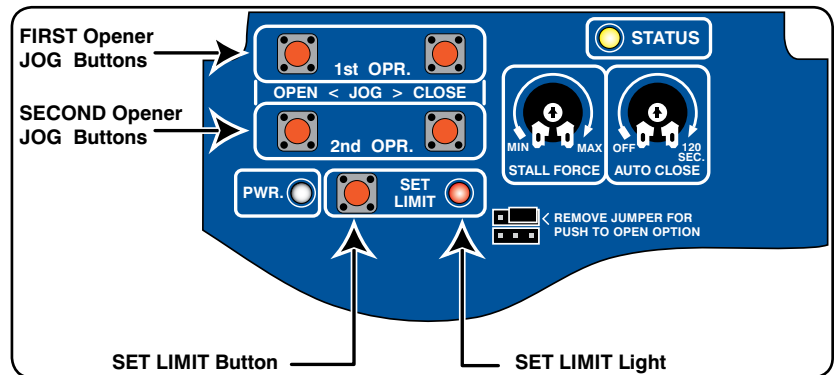

- Step 12: Adjust Stall Force Setting (page 17)
- Step 13: Set Auto Close Time (page 17)
- Step 13: Personalize Transmitter Settings (page 18)



# Connecting Accessories and Safety Devices

Although GTO strongly recommends the use of additional safety devices, we do not endorse any specific brands. Only use products that are certified and listed to be in compliance with any applicable UL standards (Underwriters Laboratories) and national and regional safety codes.

Call GTO Sales at 1-800-543-4283 for information on compatible products for your specific application.

## Step 1

Turn control box OFF before connecting safety device wires to the control board. (Unplugging the transformer does not turn power to the opener OFF.)

## Step 2

Run wires from safety devices and other accessories through the strain relief openings in the bottom of the control box.

## Step 3:

Follow directions in Accessory Installation Manuals.

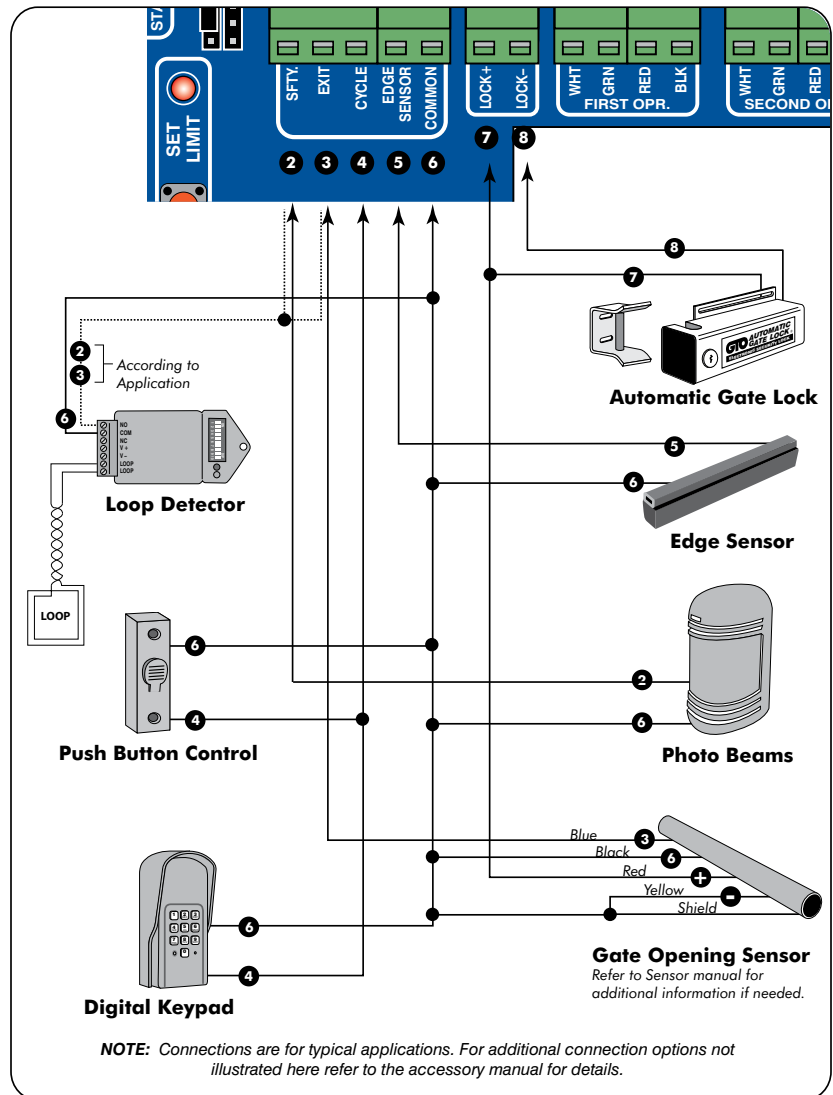
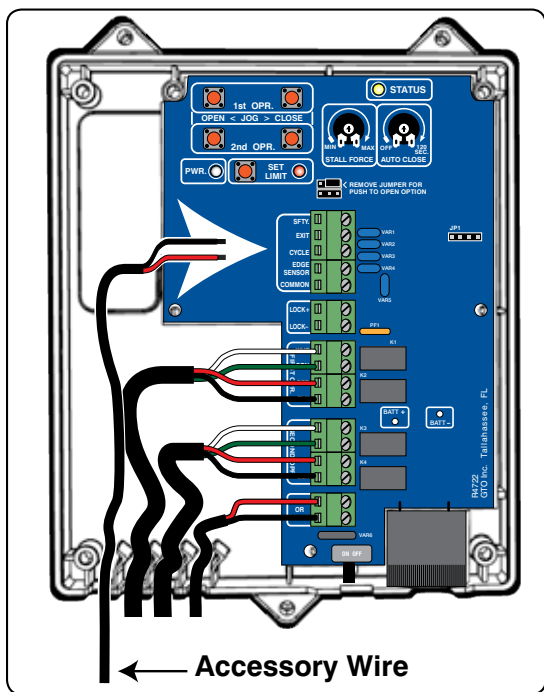



## Accessory Inputs

- 1 **SAFETY:** Typically for use with photo beam device, loop detector or other non-contact sensors
  - Activation of this input while the gate is closing will cause the gate to stop and return to the opened position.
  - Activation of this input while the gate is opening has no effect. (gate will continue to open)
  - Activation of this input while gate is idle will prevent gate from closing.
  - Activation of this input while at open limit will restart the auto close time (if enabled).
- 2 **EXIT:** Typically for use with exit loop or wand
  - Activation of this input will open the gate if it's not already at the open position.
  - Activation of this input while at open limit will restart the auto close time (if enabled).
  - Activation of this input while gate is idle will prevent gate from closing.
- 3 **CYCLE:** Typically for use with doorbell button or hardwired keypad
  - Each activation at this input will cycle the operation as follows:  
... OPEN STOP CLOSE STOP OPEN ...
- 4 **EDGE:** Typically for use with contact edge sensor
  - Activation of this input while gate is moving will cause it to reverse direction for 2 seconds.
  - Activation of this input while idle will prevent gate from running.
- 5 **COM:** Common/Negative terminal for accessory devices.

## 12 Volt Power (Maximum Current: 100 mA)

- 5 **COM:** Common/Negative terminal for accessory power source.
- 6 **LOCK +:** Power source for GTO/Mighty Mule accessories, i.e. Gate Opening Sensor [FM138].

## Lock Outputs

- 6 **LOCK +:** Positive terminal to connect Automatic Gate Lock [FM143].
- 7 **LOCK -:** Negative terminal to connect Automatic Gate Lock.

## Charge Power Inputs

- 8 **CHGR: Power Input Terminals:**
  - Input terminals for transformer or solar panel.
  - Non-polarity sensitive.

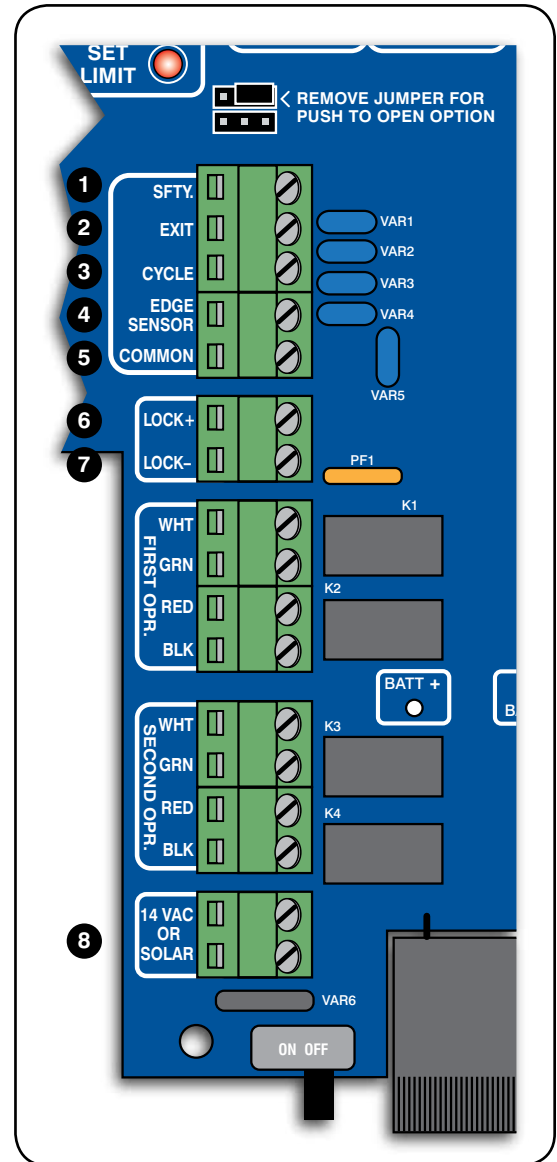

# Troubleshooting Guide



If your gate opener does not function properly, use this guide or use the online troubleshooter at <http://support.gtoinc.com> before calling the GTO Service Department.

## VISUAL AND AUDIBLE DIAGNOSTIC INDICATORS

### 1. Visual Indicators:

#### a. Power LED (Green):

- ON: AC power or Solar power is present.
- OFF: There is no input power.

#### b. Status LED (Yellow): (while unit is running this LED will be OFF)

- Rapid blinking in random pattern: GTO's transmitter 318 MHz signal is detected.
- Continuously ON: Battery is in fast charge mode.
- 1 Blink every 2 seconds: Battery is in float charge mode (battery is fully charged)
- OFF: Switch is in the OFF position or there is no input power for at least 60 seconds.

### 2. AUDIBLE INDICATOR (ALARM/BUZZER):

#### a. Beeps upon power up:

- This is normal self test when the unit is turned on.

#### b. Continuous beep after power up:

- Unit has learned new transmitter code, releasing the transmitter button will shut off the alarm or...
- Unit has entered 'LEARN LIMIT' mode, releasing the transmitter button will shut off the alarm.

#### c. Rapid beeping:

- Unit has encountered two (2) obstructions without reaching either limit. (Power cycle to reset the alarm)
- Transmitter will not operate the gate.
- Alarm will automatically shut off after 5 minutes; gate will remain disabled until control box is restarted.

#### d. 1 beep every 20 seconds:

- Low battery is detected.

#### e. 1 beep every 2 second:

- Position sensor is open circuit. Call GTO Service department.

#### f. 2 beeps every 2 second:

- Position sensor is short circuit. Call GTO Service department.

#### g. 1 beep when attempting to activate the opener:

- Blown fuse.
- Battery is extremely low or damaged.
- Loose connection from battery to circuit board.

### 3. IF THE GATE STOPS AND REVERSES DIRECTION

1. Check the position of the mounting brackets and readjust if necessary.
2. Check the gate for binding or hinge damage.
3. Adjust stall force if necessary.
4. Reprogram closed position limits.

## VOLTAGE RATINGS

14 Vac Transformer \_\_\_\_\_ 10.0 to 16.0 Vac

10 W Solar panel \_\_\_\_\_ 18.0 to 22.0 Vdc 600 mA

*Measure voltage at panel and control box.*

12 V Battery \_\_\_\_\_ 12.5 to 13.5 Vdc

Charging circuit \_\_\_\_\_ 13.8 to 14.8 Vdc

*Measure voltage at battery terminals with battery connected*

## Gate and Opener Maintenance:

1. Keep gates properly maintained. Grease hinges. Make sure gate remains level. Replace worn or damaged hardware. On gates over 250 lbs, grease ball bearing hinges at least 4 times annually (more if in a coastal area).
2. Service the gate opener regularly (make sure control box is OFF). Clean extended opener arm with a soft, dry, cloth and apply high quality silicone spray once a month. Replace battery every 1–2 years.

## Warranty Repair

If your Mighty Mule Gate Opener is not operating properly, please follow the steps below:

1. First use the procedures found in the Visual and Audible Diagnostic Indicators section (page 24).
2. Use the 24/7 Troubleshooting "Wizard" at <http://support.gtoinc.com>.
3. If you are unable to solve the problem, call the GTO Service Department at (800) 543-1236, or (850) 575-4144. Refer to the serial number (located on the back of opener arm) and date of purchase when calling for assistance.
4. If replacement of your gate opener is necessary, the Service Department will assign a **Return Goods Authorization (RGA) number** to you for all warranty repairs.
5. Securely pack the component(s) authorized for return to the factory. Write the RGA number issued to you on the outside of the package in **LARGE BOLD PRINT** and include a copy of the proof of purchase. Ship the package(s) freight prepaid to: GTO, 3121 Hartsfield Road, Tallahassee, Florida, USA 32303.

**NOTE: Products returned to GTO without a Return Goods Authorization (RGA) number in LARGE BOLD PRINT on the outside of the package WILL NOT be accepted. Also, items returned to GTO freight collect WILL NOT be accepted.**

After the two-year (24 month) warranty expires, GTO, or one of its authorized service centers will perform necessary repairs for a nominal fee. Call GTO's Technical Service Department.

## GTO Technical Service and Installation Assistance

8:00am–7:00pm • Monday–Friday (EST)

Toll Free Support: 800/543-1236 • Fax: 850/575-8950

24/7 Troubleshooting Wizard: <http://support.gtoinc.com>



GTO Access Systems, LLC  
3121 Hartsfield Road, Tallahassee, Florida, USA 32303  
[www.mightymule.com](http://www.mightymule.com)

# Accessories



Please visit [www.mightymule.com](http://www.mightymule.com) for photos and detailed descriptions of Mighty Mule Accessories. Or call 1-800-543-GATE (4283).

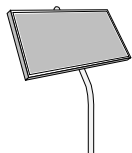

### Solar Panel (FM123) 10 watt

If your gate is more than 1000' from an AC power source, you can choose to maintain the battery charge with the Solar Panel Charging Kit. Installation in some regions of the world will require multiple solar panels for adequate charging power.

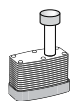

### Pin Lock (FM133)

The Pin Lock substitutes for the clevis pin at the front end of the Mighty Mule gate openers. Helps prevent theft of the opener from the gate.



### Single Button Transmitter (FM135)

The Mighty Mule entry transmitter, with adjustable settings, is standard equipment with all Mighty Mule systems. Purchase one for every vehicle in your family.



### Digital Keypad (FM137)

Allow friends and delivery personnel to pen the gate using a personal identification code that you provide. Easily program up to 25 different personal identification number (PIN) codes. The digital keypad can be wireless or wired to your opener.



### Keypad Mounting Post (FM100)

This black powder coated pedestal is designed to provide convenient access to your keypad, wireless intercom, or other access control device from your vehicle. Surface Mount Flanges (F102) and Extensions (F103) for added height are available.

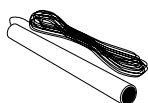

### Gate Opening Sensor (FM138)

The Sensor is an electromagnetic sensor, which offers "hands free" operation of the Mighty Mule Gate Opener with a 12 ft. radius of detection of vehicles in motion. A wireless version of the Gate Opening Sensor is available. (FM130)



### Automatic Gate Lock (FM143)

A MUST for added security. Solenoid driven, with a steel housing. Unlocks and locks automatically as gates open and close. Comes with a keyed manual release. Recommended for gates over 8 ft. long.



### Wireless Driveway Alarm (FM231)

This device alerts you of vehicles entering and exiting your property. When a vehicle passes the sensor, the receiver emits an audible tone and lets you know someone's there. Functional range of up to 400 ft. Easy-to-install.



### Low Voltage Wire (RB509)

The 16 gauge, multi-stranded, dual conductor Low Voltage Wire is for connecting the AC powered transformer, or the Solar Panel to the control board. Also used for the connection of accessories, such as locks, keypads, push buttons and other wired control devices. This specially designed wire is UV treated, PVC coated and ready for direct burial.



### Push to Open Bracket (FM148)

Required when Mighty Mule gate opener must push the gate open, such as on a sloping driveway or where space prevents gate(s) from opening inward (pulled open). Order two brackets for conversion of a dual swing gate installation.