

MIGHTY MULE

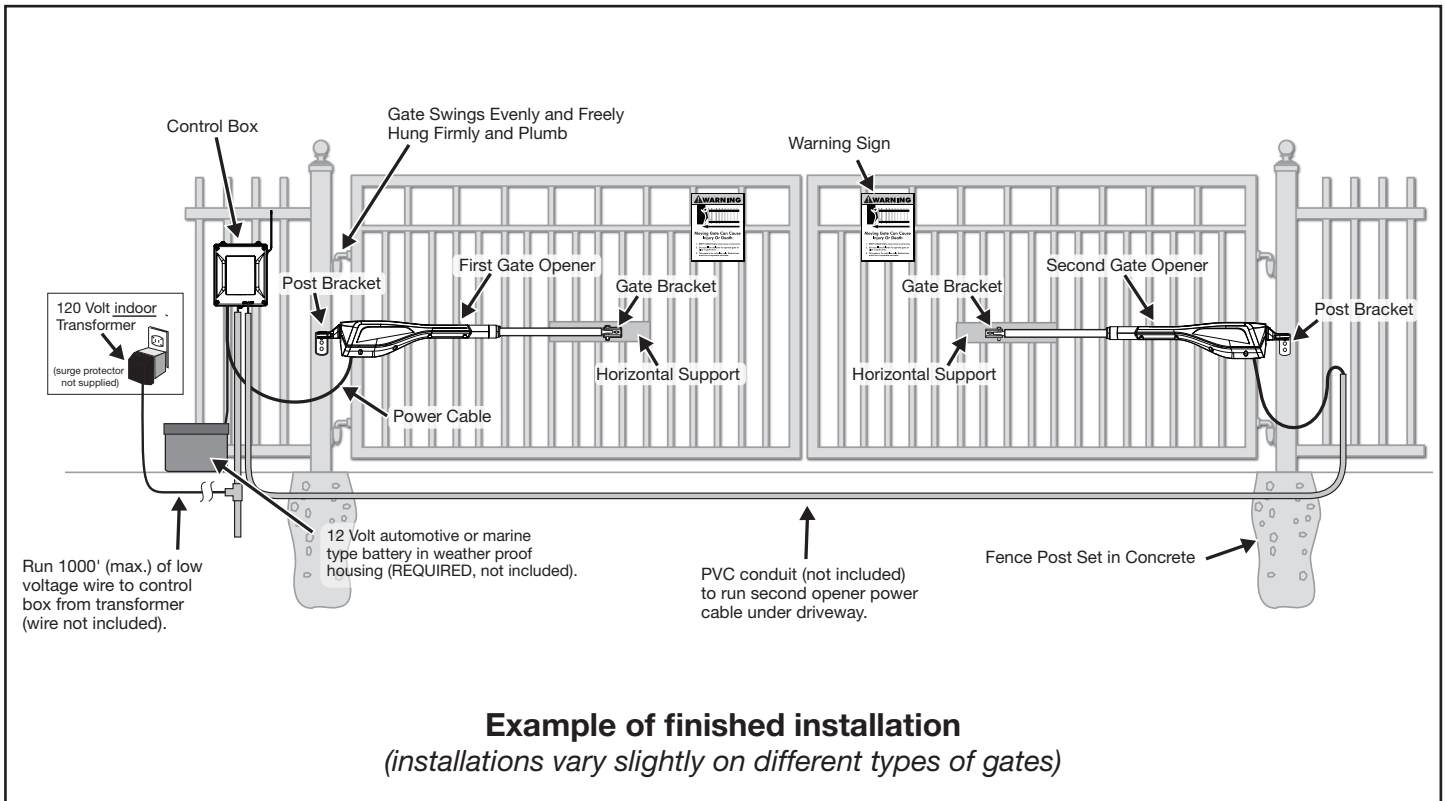

MM272

Installation Manual



This product meets the requirements of UL325, the standard for gate operator safety.

NSC Sales: 800-543-4283 • Fax 850-575-8912

NSC Technical Service 800-543-1236

For Online Technical Support 24 hour/day, 7 day/week visit www.mightymule.com

For more information on Mighty Mule's full line of Automatic Gate Operators and

Access Controls visit www.mightymule.com

Mighty Mule® is the retail brand of Nortek Security & Control, LLC

NORTEK
SECURITY & CONTROL

WARNING

This equipment meets Underwriters Laboratory Standard 325 (UL 325). However, gate equipment has hazards associated with its use and therefore by installing this product the installer and user accept full responsibility for following and noting the installation and safety instructions. Failure to follow installation and safety instructions can result in hazards developing due to improper assembly. You agree to properly install this product and that if you fail to do so Nortek Security & Control, LLC, shall in no event be liable for direct, indirect, incidental, special or consequential damages or loss of profits whether based in contract tort or any other legal theory during the course of the warranty or at any time thereafter. The installer and/or user agree to assume responsibility for all liability and use of this product releasing Nortek Security & Control, LLC, from any and all liability. If you are not in agreement with this disclaimer or do not feel capable of properly following all installation and safety instructions you may return this product for full replacement value.

READ ALL INSTRUCTIONS CAREFULLY AND COMPLETELY before attempting to install and use this automatic gate operator. This gate operator produces a high level of force. Stay clear of the unit while it is operating and exercise caution at all times.

ALL AUTOMATIC GATE OPERATORS ARE INTENDED FOR USE ON VEHICULAR GATES ONLY.

Product Usage

The Mighty Mule Gate Operator meets all of the safety requirements of a **Class I** Residential Vehicular Gate Operator and is intended for use solely with vehicular swing gates in single-family residential applications that meet the Class I category listed in the table below.

Vehicular Gate Operator Class Categories

Residential Vehicular Gate Operator-Class I:

A vehicular gate operator (or system) intended for use in garages or parking areas associated with a residence of one-to-four single families.

Commercial/General Access Vehicular Gate Operator-

Class II: A vehicular gate operator (or system) intended for use in a commercial location or building such as a multi-family housing unit (five or more single family units), hotel, garages, retail store, or other buildings accessible by or servicing the general public.

Industrial/Limited Access Vehicular Gate Operator-

Class III: A vehicular gate operator (or system) intended for use in an industrial location or building such as a factory or loading dock area or other locations not accessible by or intended to service the general public.

Restricted Access Vehicular Gate Operator-

Class IV: A vehicular gate operator (or system) intended for use in an industrial location or building such as a factory or loading dock area or other locations not accessible by or intended to service the general public.

Table of Contents

| | |
|--|------------|
| Please Read This First! | ii |
| Manually Opening and Closing Gate..... | iii |
| Important Safety Information | iii |
| For the Installer and End User | iv |
| Installing Warning Signs and Pedestrian Gates | viii |
| Required Safety Precautions for Gates | ix |
| Technical Specifications | 1 |
| Before You Begin | 2 |
| Solar Panel and Gate Activity Chart | 2 |
| Parts List – Opener and Mounting Hardware | 4 |
| Tools and Materials..... | 5 |
| Installation Overview for Pull-To-Open Gates..... | 6 |
| Installation of the FIRST Gate Opener | 7 |
| Install Post Bracket Assembly and Gate Bracket..... | 8 |
| Attach Opener Arm..... | 10 |
| Install the Closed Position Stop Plates | 11 |
| Mount the Control Box..... | 12 |
| Connect Opener Power Cables | 13 |
| Connect the Transformer | 13 |
| Connect Battery Harness to Control Board | 15 |
| Connect the Battery | 16 |
| Set the CLOSED Position Limit for PULL-TO-OPEN Installation..... | 16 |
| Setting Dual Sense Detection and Auto Close Timer | 17 |
| Personalize Your Transmitter Setting | 18 |
| Push-To-Open Installation Instructions | 19 |
| Solar Panel Instructions | 21 |
| Connecting Additional Devices | 22 |
| Troubleshooting Guide | 24 |
| Maintenance | 25 |
| Warranty Repair | 25 |
| Accessories | 26 |
| Gate Operator Installation Checklist..... | 28 |

Please Read This First!

Thank you for purchasing a Mighty Mule Gate Operator—the "do-it-yourself" automatic gate operator! When correctly installed and properly used, your Mighty Mule Gate Operator will give you many years of reliable service. Please read the following information and watch the enclosed video to ensure you have the correct system for your particular needs. Furthermore, this manual and the DVD will enable you to properly install your Mighty Mule Gate Operator.

The MM272 Operator is designed for installation on a pull-to-open dual leaf gates (gates that open into the property). By purchasing the accessory brackets, the Mighty Mule Gate Operator can accommodate a push-to-open dual leaf gates (gates that open out from the property). The gate must not exceed 12 feet in length and weigh more than 300 pounds (please see Technical Specifications on [page 1](#)). The Mighty Mule Gate Operator can be used on vinyl, aluminum, chain link, farm tube, and wrought iron gates. Use on solid surface gates is not recommended. Solid surface gates have a high resistance to the wind. If the wind is strong enough, the operator will obstruct and stop, and may damage the opener.

The Mighty Mule Gate Operator accommodates extra transmitters, digital keypads, solar panels, push buttons, automatic gate locks, and other access control products. These optional accessories (see the Mighty Mule Accessory Catalog) are available at most stores. Your store should be able to special order any accessory not in stock. If your store cannot special order accessories, please call the Mighty Mule Sales Department (800-543-GATE).

The Mighty Mule Gate Operator features Dual Sense Technology™. This feature makes the gate stop and reverse direction when it comes in contact with an obstruction. This is factory set to the most sensitive setting and must be adjusted during installation.

The Mighty Mule Gate Operator also has an adjustable auto-close feature. After the gate reaches the fully open position, it can be set to remain open up to 120 seconds before automatically closing. Pressing the transmitter button at any time after the gate opens fully will cause it to close immediately. OFF is the factory setting; meaning the gate will stay open until you press the transmitter (or keypad, etc.) again.

Go to www.mightymule.com or call (800) 543-4283 to find a retailer near you. For information about our professional line of gate operators and accessories, visit www.linearproaccess.com.

BEFORE YOU BEGIN TO INSTALL YOUR AUTOMATIC GATE OPERATOR:

Watch the enclosed video and read these instructions carefully and completely to become familiar with all parts and installation steps. The video is only designed as an overview of the installation procedure. You must read the installation manual for detailed instructions on gate operator safety and proper use of the gate operator.



Important Safety Information

Because automatic gate operators produce high levels of force, consumers need to know the potential hazards associated with improperly designed, installed, and maintained automated gate operator systems. **Keep in mind that the gate operator is just one component of the total gate operating system.** Each component must work in unison to provide the end user with convenience, security, and safety.

This manual contains various safety precautions and warnings for the installer and end user. Because there are many possible applications of the gate operator, the safety precautions and warnings contained in

this manual cannot be completely exhaustive in nature. They do, however, provide an overview of the safe design, installation, and use of this product. **CAREFULLY READ AND FOLLOW ALL SAFETY PRECAUTIONS, WARNINGS, AND INSTALLATION INSTRUCTIONS TO ENSURE THE SAFE SYSTEM DESIGN, INSTALLATION, AND USE OF THIS PRODUCT.**



Warnings in this manual are identified with this warning symbol. The symbol identifies conditions that can result in damage to the operator or its components, serious injury, or death.

Because Mighty Mule automatic gate operators are only part of the total gate operating system, it is the responsibility of the installer and end user to ensure that the total system is safe for its intended use.

Manually Opening and Closing Gate

CAUTION

The gate will move freely and uncontrolled when the gate operator is removed from the gate. **ONLY** disconnect the operator when the control box power switch is OFF and the gate is NOT moving.

Disconnecting the Operator

1. Turn control box power switch OFF.
2. Remove hairpin clip, clevis pin, and bushing from either the front or rear mounting point.
3. Remove the operator from the mount.

The gate can be opened and closed manually when the operator is disconnected.

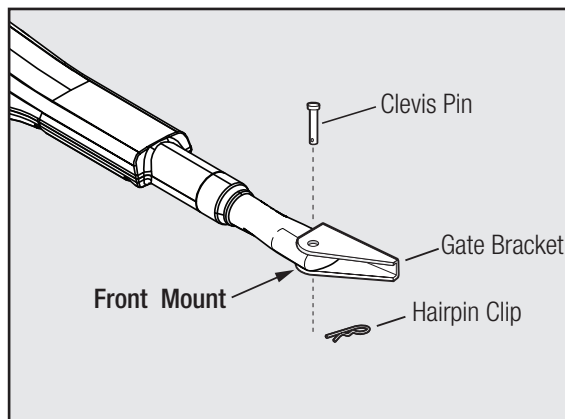

NOTE: Substitute a **Pin Lock** for the clevis pin on the front mount of the gate operator to prevent unauthorized removal of the operator from the gate (*see accessory pages in back of this book*).

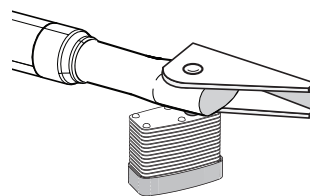

Important Safety Information

For the Installer and End User

! WARNING

To reduce the risk of injury or death:

1. **READ AND FOLLOW ALL INSTRUCTIONS.**
2. Never let children operate or play with gate controls. Keep the remote control away from children.
3. Always keep people and objects away from the gate. **NO ONE SHOULD CROSS THE PATH OF THE MOVING GATE.**
4. Test the gate operator monthly. The gate **MUST** reverse on contact with a rigid object or stop when an object activates the non-contact sensors. After adjusting the force or the limit of travel, retest the gate operator. Failure to adjust and retest the gate operator properly can increase the risk of injury or death.
5. Use the manual/emergency release only when the gate is not moving.
6. **KEEP GATES PROPERLY MAINTAINED.** Read the user's manual. Have a qualified service person make repairs to gate hardware.
7. The entrance is for vehicles only. Pedestrians must use separate entrance.
8. The gate must be installed in a location that provides adequate clearance between it and adjacent structures when opening and closing to reduce the risk of entrapment. Swinging gates must not open into public access areas.

I. Before Installation

1. Verify this operator is proper for the type and size of gate, frequency of use and class of the gate system.
2. Make sure the gate has been properly installed and swings freely in both directions. Repair or replace all worn or damaged gate hardware prior to installation. A freely moving gate will require less force to operate and will enhance the performance of the entrapment protection devices used with the system (see Prepare the Gates on [page 3](#)).
3. Review the operation of the system to become familiar with its safety features. Understand how to disconnect the operator for manual gate operation (see [page iii](#)).
4. The gate and operator installation must comply with any applicable local codes.
5. This gate operator is intended for vehicular gates only. A separate entrance or gate must be installed for pedestrian use (see [page viii](#)).
6. Always keep people and objects away from the gate and its area of travel. No one should cross the path of a moving gate.
7. Identify all of the entrapment zones for the type of installation. An entrapment zone is an area around the automatic gate system where a person or object could be caught that increase the risk of injury. Entrapment zones must be eliminated, guarded or protected.
8. When designing a system that will be entered from a highway or main thoroughfare, make sure the gate system is placed far enough from the road to prevent traffic congestion.

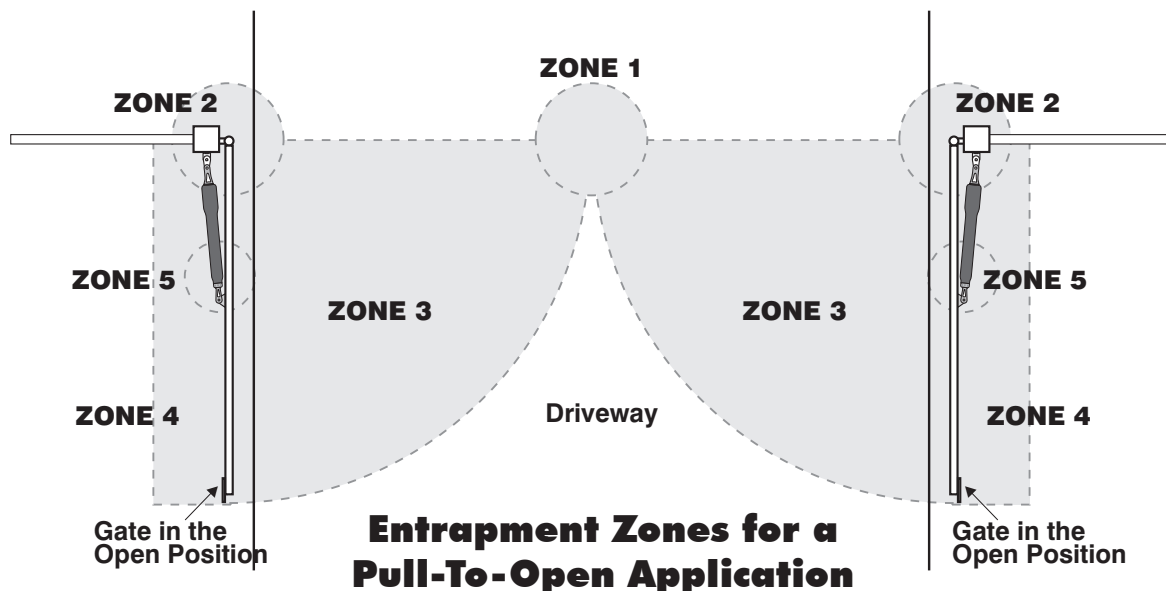

Important Safety Information

For the Installer and End User

Typical Entrapment Zones are shown in the diagrams on [page iv](#):

Zone 1 – leading edge of the gate and the fence post.

Zone 2 – between the gate and the gate post.

Zone 3 – the path of the gate.

Zone 4 – the space between the gate in the open position and any object such as a wall, fence, tree, etc.

Zone 5 – pinch points between the operator and gate.

II. During Installation

1. Install the gate operator on the inside of the property and fence line. **DO NOT** install an operator on the outside of the gate where the public has access to it.
2. Be careful with moving parts and avoid close proximity to areas where fingers or hands could be pinched.
3. Devices such as contact sensors (sensing edges) and non contact sensors (photo beams) provide additional protection against vehicular damage.
4. If push buttons or key switches are installed, they should be within sight of the gate, located at least 10 feet from any moving part of the gate (see diagram below). **Never install any control device where a user will be tempted to reach through the gate to activate the gate operator.**
5. Do not activate your gate operator unless you can see it and can determine that its area of travel is clear of people, pets, or other obstructions. Watch the gate through its entire movement.
6. Secure outdoor or easily accessed gate operator controls in order to prohibit unauthorized use of the gate.

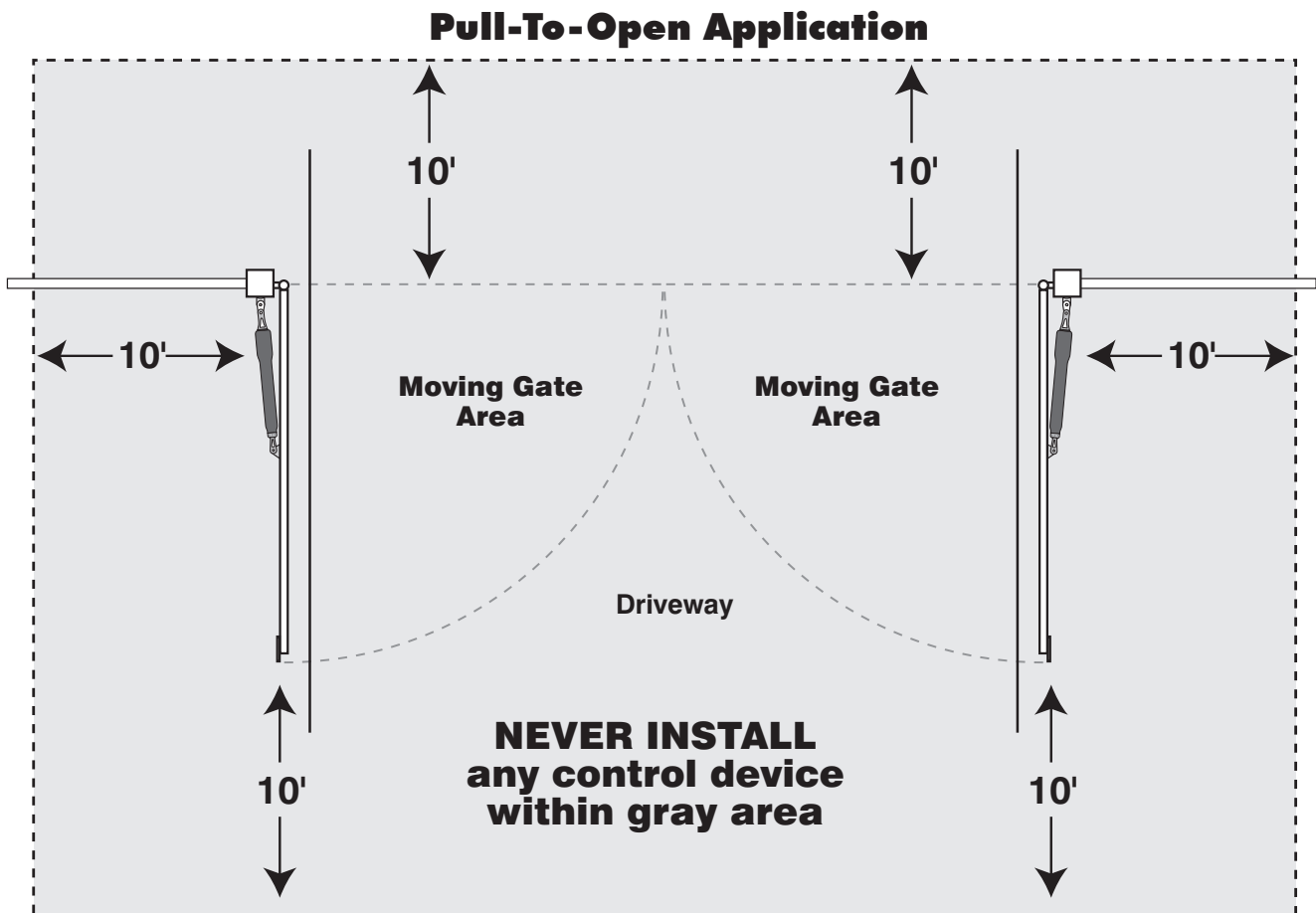

Important Safety Information

For the Installer and End User

III. After Installation

1. Attach the **warning signs** (included) to each side of the gate to alert the public of automatic gate operation. It is your responsibility to post warning signs on both sides of your gate. If any of these signs or warning decals becomes damaged, illegible, or missing, replace them immediately. Contact NSC for free replacements.
2. The gate is automatic and could move at any time, posing serious risk of entrapment. No one should be in contact with the gate when it is moving or stationary.
3. Do not attempt to drive into the gate area while the gate is moving; wait until the gate comes to a complete stop.
4. Do not attempt to “beat the gate” while the gate is closing. This is extremely dangerous.
5. Do not allow children or pets near your gate. **Never let children operate or play with gate controls.** Keep the remote control away from children and unauthorized users; store controls where children and unauthorized users do not have access to them.
6. **KEEP GATE SYSTEMS MAINTAINED.** Always turn power to operator OFF before performing any maintenance. See [page 26](#) for maintenance procedures.
7. To operate this equipment safely, YOU must know how to disconnect the operator for manual gate operation (see [page iii](#)). If you have read the instructions and still do not understand how to disconnect the operator, contact the Mighty Mule Service Department.
8. Disconnect the operator **ONLY** when the power is **TURNED OFF** and the gate is **NOT** moving.
9. Make arrangements with local fire and law enforcement for emergency access.
10. Distribute and discuss copies of the **IMPORTANT SAFETY INFORMATION** section of this manual with all persons authorized to use your gate.
11. **IMPORTANT: Save these safety instructions. Make sure everyone who is using or will be around the gate and gate operator are aware of the dangers associated with automated gate systems. In the event you sell the property with the gate operator or sell the gate operator, provide a copy of these safety instructions to the new owner.**

Should you need a replacement manual, a copy can be obtained by downloading one from the Mighty Mule web site (www.mightymule.com), by contacting NSC by calling 1-800-543-4283 and requesting a duplicate copy. One will be provided to you.

Important Safety Information

For the Installer and End User

Mighty Mule gate operators utilize Dual Sense Technology™ entrapment protection. Dual Sense Technology™ is built into every Mighty Mule and provides redundant methods of entrapment protection for open and close gate directions.

In addition to Dual Sense Technology, every Mighty Mule gate controller has provisions for the connection of additional obstruction detection devices such as sensing edges and photo beams.

These devices may be located where there is an increased risk of obstruction. Refer to the diagram below.

One or more edge sensors may be located at the leading edge, bottom edge, and post edge, both inside and outside of a vehicular swing gate system.

Wiring to sensors must be located and arranged so the wiring between the sensor and the gate operator is not subjected to mechanical damage.

A wireless sensor such as one that transmits radio frequency (RF) signals to the gate operator for obstruction protection functions shall be located where the transmission of the signals is not blocked or impeded by building structures, natural landscaping or similar objects.

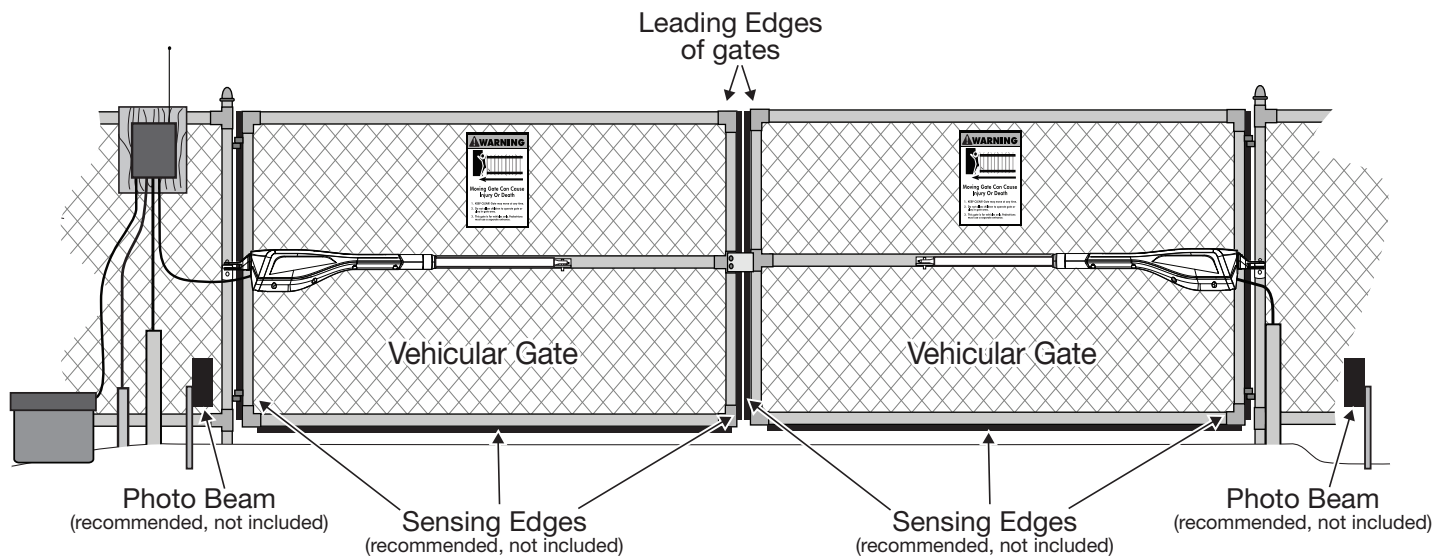

Entrapment and Obstruction Protection

Mighty Mules' Dual Sense Technology™ provides entrapment protection when properly adjusted. Since all installations are different, you may need to add photo beams or sensing edges to help prevent damage to vehicle or other items that could be hit by a moving gate.

Entrapment Alarm

The Mighty Mule Automatic Gate Operator is designed to stop and reverse the gate when the gate comes in contact with an obstruction. Additionally, these operators are equipped with an audio entrapment alarm which will activate if the unit obstructs twice while opening or closing. This alarm will sound for a period of 5 minutes, or until the operator receives an intended signal from a hard wired entry/exit source (e.g. push button control or keypad) and the gate returns to a fully open or fully closed position. Turning the power switch on the control box OFF and back ON will also deactivate the alarm. Wireless controls such as transmitters and wireless keypads will not deactivate the alarm.

Important Safety Information

Installing Warning Signs and Pedestrian Gates

Warning signs alert people of automatic gate operation and are required when installing Mighty Mule Automatic Gate Operators. A minimum of two WARNING SIGNS must be installed in the area of the gate. Each sign is to be visible by persons located on the side of the gate on which the placard is installed.

The operator is intended for installation only on gates used for vehicles. Pedestrians must be supplied with a separate access opening. The pedestrian access opening shall be designed to promote pedestrian usage. Locate the gate such that persons will not come in contact with the vehicular gate during the entire path of travel of the vehicular gate.

We recommend using the NSC Pedestrian Gate Lock (Call the NSC Sales Department at 800-543-4283) for controlled access.

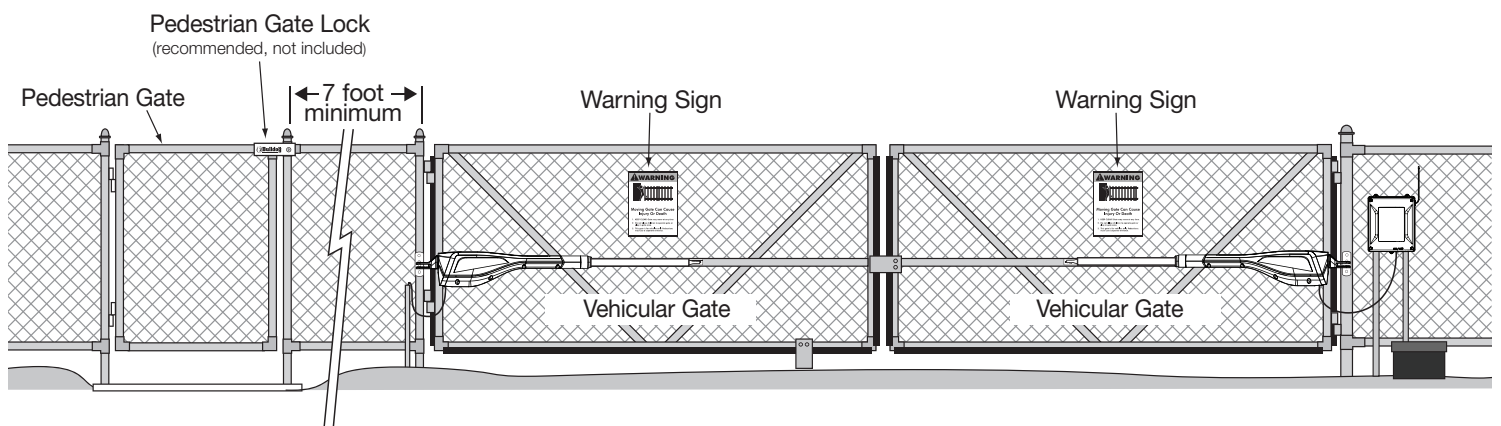

Warning Signs

The gate operator is provided with 2 safety warning signs. The signs **MUST** be installed on the front and back of the gate where they will be visible in the area of the gate.

Permanently secure each warning sign to the gate.

Immediately replace a damaged or missing warning sign.



Important Safety Information

Required Safety Precautions for Gates

These warning labels should be found at the locations specified below. If any of them are missing, immediately contact NSC for replacements.



Labels (1) installed on the front of control box

Technical Specifications

MIGHTY MULE MM272 DUAL GATE OPENER

DRIVE

- Low friction screw drive (linear actuator) rated for -5 °F to +160 °F (-20 °C to +71 °C).
- Powered by a 12 V motor with integral case hardened steel gear reducer. Motor speed reduced to 260 rpm. Generates 520 inch lb. of torque at 12 V.
- Maximum opening arc of 110°. Approximate opening time (90°): 18 seconds, depending on weight of gate.

POWER

- The system is powered by a 12 Vdc automotive, lawn tractor or marine battery (required but not included).
- Battery charge is 120Vac to 16Vac output through the control board] or by optional Solar Panels; the panel should generate minimum of 10 Watts (600 mA). A diode on the control board prevents battery discharge. **IMPORTANT:** Never use *both* transformer and solar panel— this will damage the battery and control board.
- One (1) blade-style fuse is rated for 15A.

NOTE: The transformer should not be directly connected to any battery. Do not replace fuses with higher ampere rated fuses; doing so will void your warranty and may damage your control board.

CONTROL

- Microprocessor-based control board is set for dual leaf, pull-to-open gate installations. Jumper can be removed to accommodate an optional kit for push-to-open gates.
- Control board has temperature compensated circuits.
- Auto-memorization of digital transmitter code.
- Opener length with push-pull tube fully retracted is 26 ³/₈" , mounting point to mounting point. Maximum stroke is 13".
- Adjustable auto-close timer (OFF to 3–120 seconds), and Dual Sense Technology™ stall force).
- Power terminal block accommodates a transformer or solar panels.
- Accessory terminal block fully compatible with all Mighty Mule access controls.
- Control board allows connection of edge sensors and photoelectric sensors.
- Audio entrapment alarm sounds if unit encounters an obstruction twice while opening or closing.

OPERATIONAL CAPACITY

- Maximum gate size: 300 lbs., 12' long.

NOTE: BALL BEARING HINGES SHOULD BE USED ON ALL GATES WEIGHING OVER 250 LB.

Before You Begin

1. Determine Charging Options for Battery: Transformer OR Solar

NEVER USE TRANSFORMER AND SOLAR PANEL(S) AT THE SAME TIME!
It will damage the control board!

IMPORTANT

- The Mighty Mule 272 is designed and intended for use with a 12 Volt automotive, marine or lawn tractor battery. The battery must be placed inside a weatherproof case and located within 6' of the control box. **The 8' battery harness connects the battery to the control board.**
- The battery charge is maintained by the 16 Volt transformer included **OR** optional solar panel(s). The transformer **OR** solar panel is connected to the control board using low voltage, 16 gauge, dual conductor, multi-stranded, direct burial wire [RB509] ([page 26](#)).
- All low voltage wire used with the Mighty Mule Gate Opener must be 16 gauge dual conductor, multi-stranded, direct burial wire.
- The transformer is intended for indoor use. If the transformer can only be plugged into an outside electrical outlet, a weatherproof cover or housing **must** be used.
- If your gate is more than 1000' from an AC power source, you will need to use a solar panel charging kit (**minimum 10 watts**) . Refer to the Solar Panels and Gate Activity Chart below.

Solar Panel and Gate Activity Chart

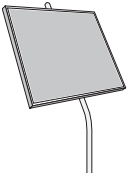

The table and map illustrate the maximum number of gate cycles to expect per day in a particular area when using from 10 to 20 watts of solar charging power prior to the battery depleting to a state where the unit will not function. The figures shown are for winter (minimum sunlight) and do not account for the use of any accessory items.

Accessories connected to your system will draw additional power from the battery and will require additional solar panels.

A deep cycle marine battery is recommended for solar and/or high traffic applications.

NOTE: UP to 250 ft. of dual conductor, 16 gauge, multi-stranded wire may be used to allow installation of solar panels in direct sunlight.

See [page 21](#):

10 Watt Solar Panel [FM123]

| Dual Gate Winter Ratings | Zone 1 | Zone 2 | Zone 3 |
|--------------------------|--------|--------|--------|
| 10 Watts | 8 | 16 | 26 |
| 20 Watts | 14 | 28 | 38 |

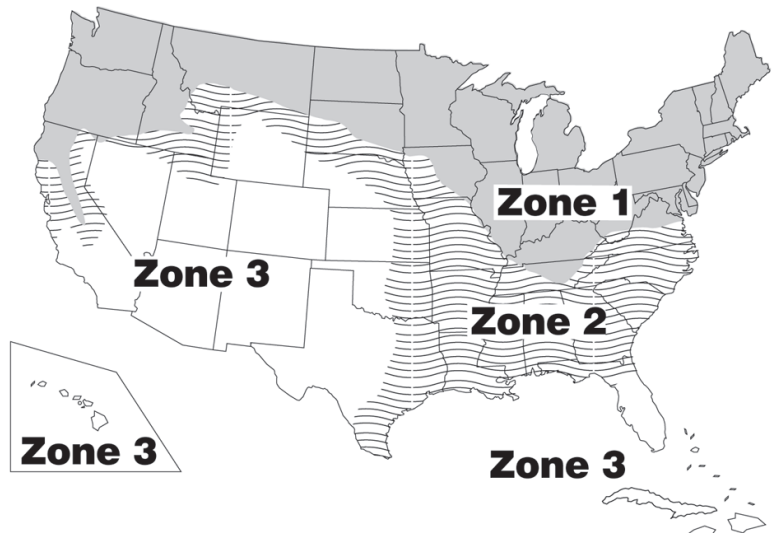

2. Check Direction of Gate Swing

The Mighty Mule 272 is designed for **PULL-TO-OPEN** installations. **PUSH-TO-OPEN** installations require two Push-To-Open brackets [FM148]. Push-to-Open Installation Instructions begin on [page 27](#).

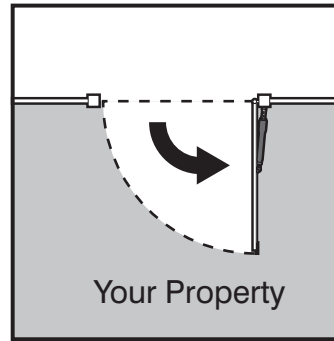

Pull-To-Open
(arm retracts to open)

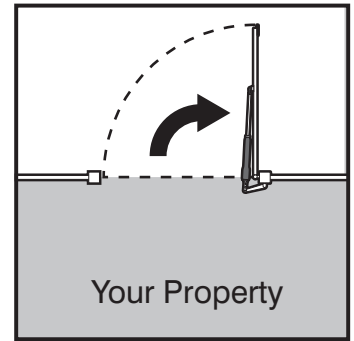

Push-To-Open
(arm extends to open)

3. Prepare the Gates

- Gates must be plumb, level, and swing freely on their hinges.
- Wheels must **NOT** be attached to the gates.
- The gates must move throughout their arcs **without binding or dragging on the ground**.
- Note that gates **over 250 lb. should have ball bearing hinges** with grease fittings.
- The gate post should be secured in the ground with concrete so it will minimize twist or flex when the opener is activated.
- The addition of a **horizontal or vertical cross member** (if one is not already in place) to provide a stable area for mounting the gate bracket is also important.
- Trench the driveway in order to lay PVC conduit for the second opener power cable (see illustration on [page 6](#)).

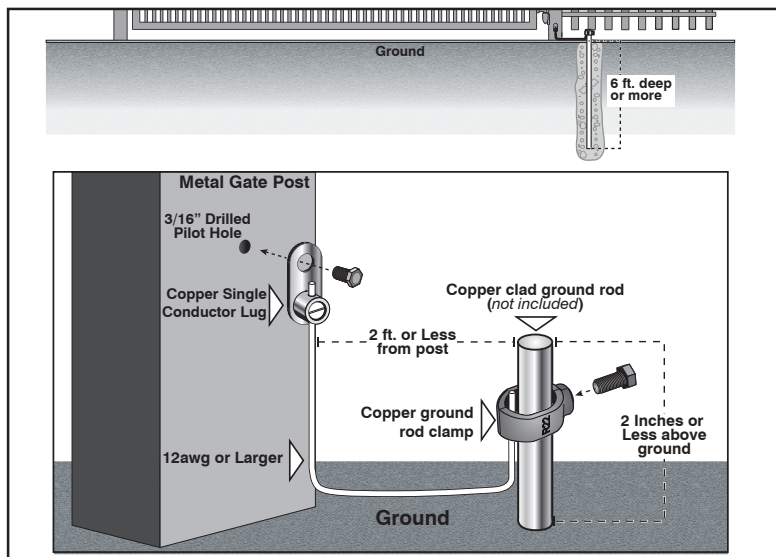
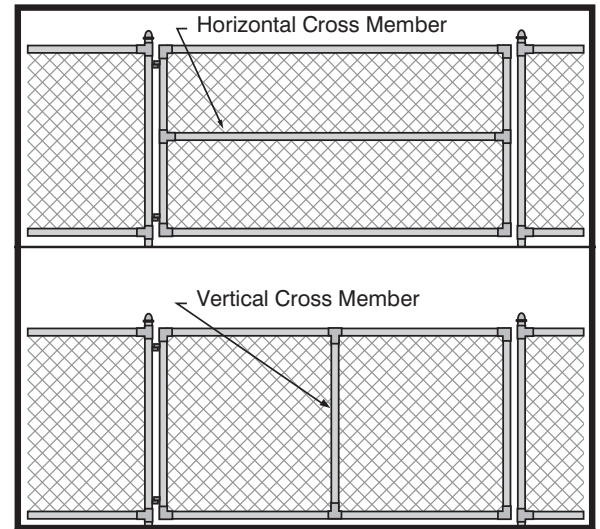
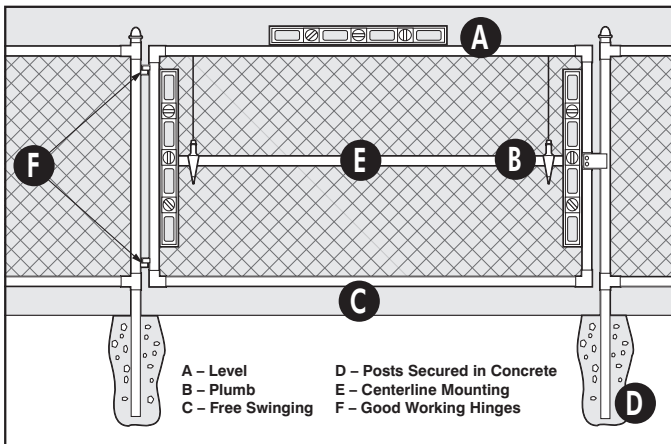

Gate Grounding (recommended)

- Shorter wire (6 AWG) is better, 1 to 2 feet recommended.
- Bolt ring terminal at end of cable 4 - 6 inches above ground level.

NOTE: No grounding system absolutely protects against lightning strikes. If installed correctly, a grounding system will help minimize damage to your gate opener.

Parts List – Opener and Mounting Hardware



Battery Wire Harness with 15A fuse (1)

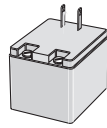

Transformer (1)
RB503



Warning Signs (2)

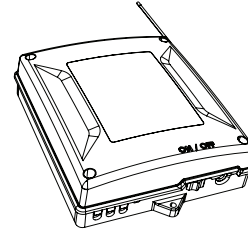

Control Box (1)

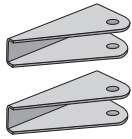

Gate Bracket (2)



Transmitter (1)
MMT103

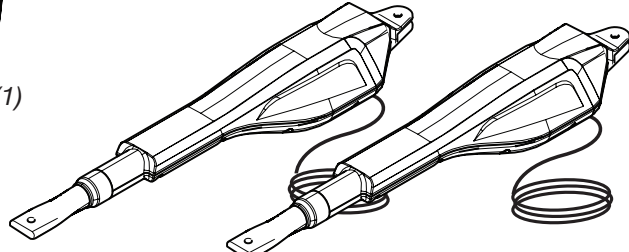

Gate Opener (2)

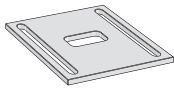

Closed Position Stop Plate (2)

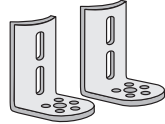

Post Bracket (2)

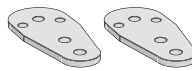

Post Pivot Bracket (2)



Literature Kit

Hardware Bag Contents

8" Nylon Cable Tie (20)

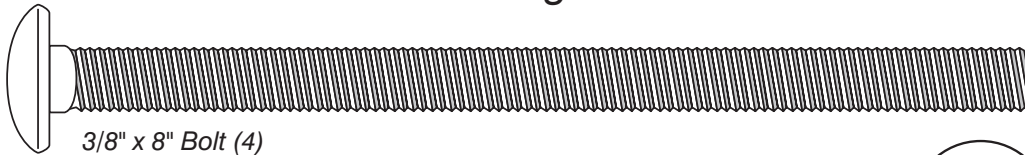

3/8" x 8" Bolt (4)

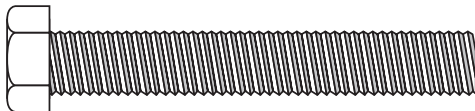

3/8" x 2-3/4" Bolt (4)

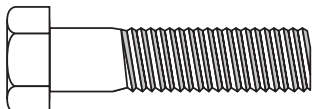

3/8" x 1-1/4" Bolt (2)

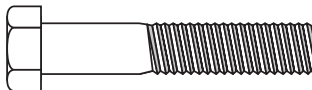

5/16" x 1-1/4" Bolt (2)

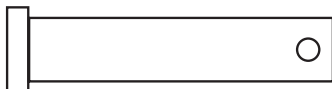

3/8" x 1-1/2" Clevis Pin (4)

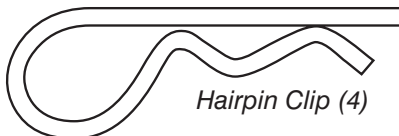

Hairpin Clip (4)



2" Mounting Screw (3)

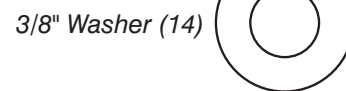

3/8" Washer (14)

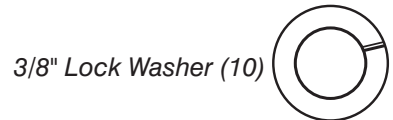

3/8" Lock Washer (10)

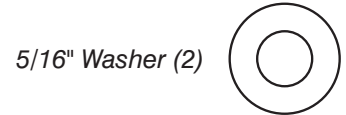

5/16" Washer (2)

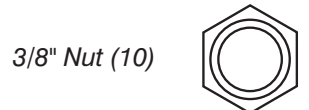

3/8" Nut (10)



5/16" Lock Nut (2)

Tools and Materials

Tools Needed:

- Power Drill
- Open End Wrenches — 1/2" and 9/16"
- Adjustable Wrench
- 3/8" Drill Bit
- Hacksaw or Heavy Duty Bolt Cutters
- Small Flat Bladed Screwdriver
- Large Phillips Screwdriver
- Tape Measure
- Level
- Wire Strippers
- C-Clamps — small, medium, and large
- Center Punch
- Hammer (for center punch)
- Extra person will be helpful

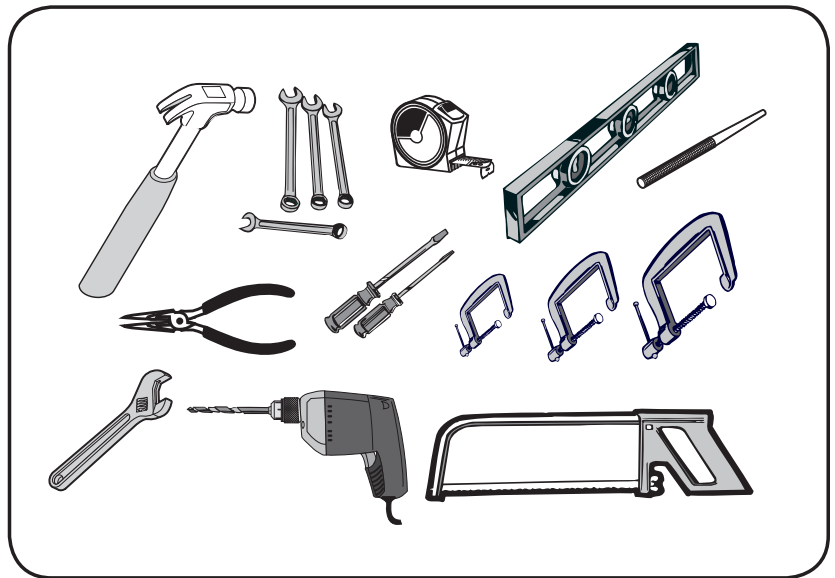

NOT ALL TOOLS ARE SHOWN

Materials You May Need for the Installation:

These items are **NOT included** with the gate opener kit. Some of these items can be purchased or special ordered through participating retailers. Please see [page 26](#) or www.mightymule.com

- 12 VDC automotive/lawn tractor or deep cycle marine battery **is required** to power the opener. ([page 2](#))
- Low voltage wire [RB509] will be needed to run from the transformer to the opener control board; length depends upon the distance between the transformer power supply and the control box. ([page 13](#) & [20](#))
- If your gate is more than 1000' away from an AC power source you will need to use at least one 10 watt Solar Panel [FM123] to charge the 12 Volt battery. ([page 2](#) & [26](#))
- PVC conduit for protecting in ground wiring. ([page 6](#))
- Push-To-Open Brackets [FM148] are required if gates open out from property. ([page 3](#) & [20](#))
- Materials to reinforce thin walled tube or panel gates. ([page 7](#))
- Depending on the type of gate, a horizontal cross member or mounting plate may be needed to mount the front of the opener and gate bracket to the gate. ([page 3](#) & [7](#))
- Some installations may require muffler clamps for the gate bracket, to prevent drilling into thin wall tube gates. ([page 7](#))
- (2)16 AWG crimp on fork lugs. ([page 15](#))
- Surge protection for transformer. ([page 16](#))
- Weather proof outlet and cover is required if transformer is plugged into outside outlet. ([page 16](#))
- Some types of installations require U-Bolts for closed position stop plate. ([page 11](#))
- A low profile ground stop is required for dual gates when using the Mighty Mule gate lock. ([page 11](#))

Installation Overview for Pull-To-Open Gates

PUSH-TO-OPEN installation instructions begin on [page 19](#).

Example of an installation on a chain link fence:

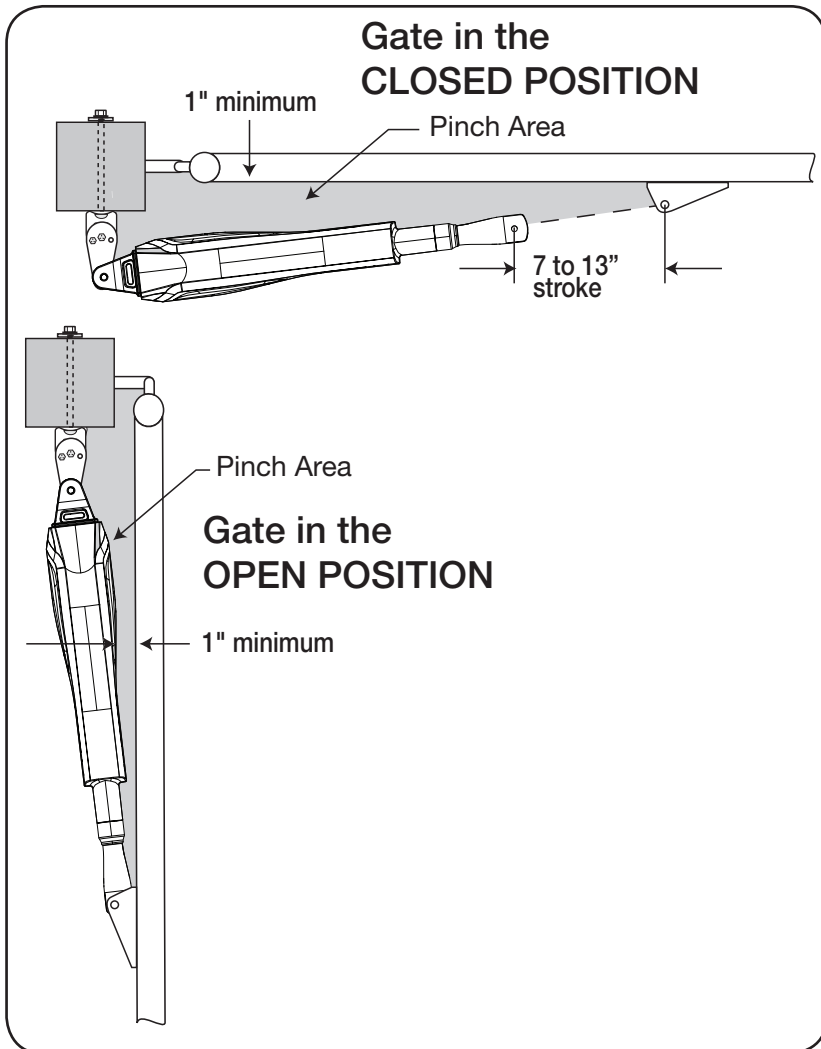
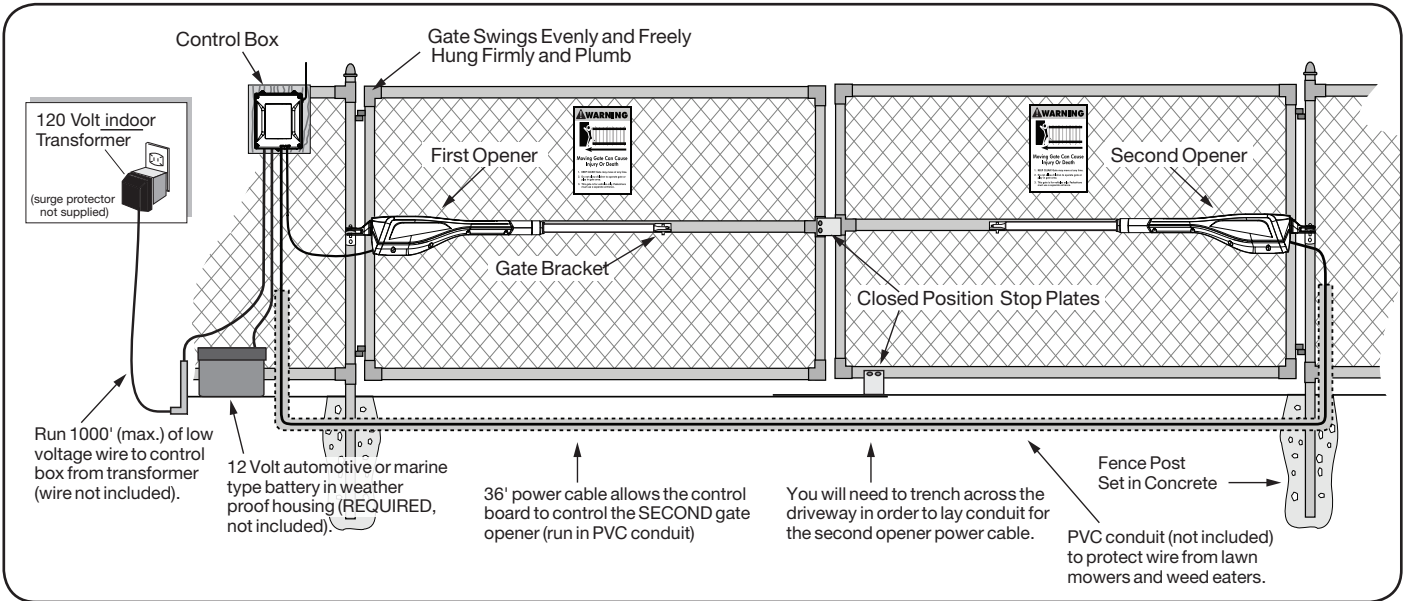

IMPORTANT: To achieve the most efficient leverage for the gate opener and ensure long trouble free service, the gate opener needs to be installed within the following parameters.

The diagram at left shows the optimum position for gate opener arm in relation to the gate in the open and closed positions. Be sure the position of the gate opener and brackets allows for 1" of clearance between the gate and the opener in both the open and closed position, at the same time maintaining a stroke distance of 7" to 13" from center of hole in the end of the retracted opener arm to the center of the hole in the gate bracket with the gate in the closed position.

If the gate post is larger than 6" the Post Pivot Bracket can be removed and the center hole of the Post Bracket can be the mounting point for the gate opener.

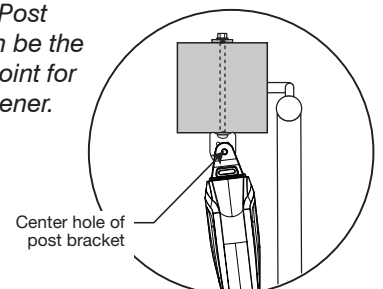

Installation of the FIRST Gate Opener

IMPORTANT: Determine which side of the driveway you will mount the control box. From this point on, the gate and gate opener on the same side as the control box will be referred to as the **FIRST** gate and gate opener. The gate and gate opener on the opposite side of the driveway from the control box will be referred to as the **SECOND** gate and gate opener.

We recommend you position the opener near the **centerline** of the gate to keep the gate from twisting and flexing and to avoid back splash from rain water.

The Post Bracket Assembly

The position of the post bracket assembly determines the leverage and efficiency of the opener. The post bracket assembly position also sets the clearance between the opener and the gate in the open and closed positions.

The post bracket works well for installations on round and square fence posts. Because the post bracket carries the entire thrust of the active opener, **bolts must completely penetrate the post.**

On wood posts, place a metal plate or washer (not supplied) between the nuts and the post to prevent the thrust of the opener from pulling the bolts and washers out of the wood.

The post pivot bracket may not be necessary on posts larger than 6" in diameter (see [page 6](#)). Fence posts smaller than 6" in diameter or 6" square should be made of metal instead of wood to remain stable while the opener is moving the gate.

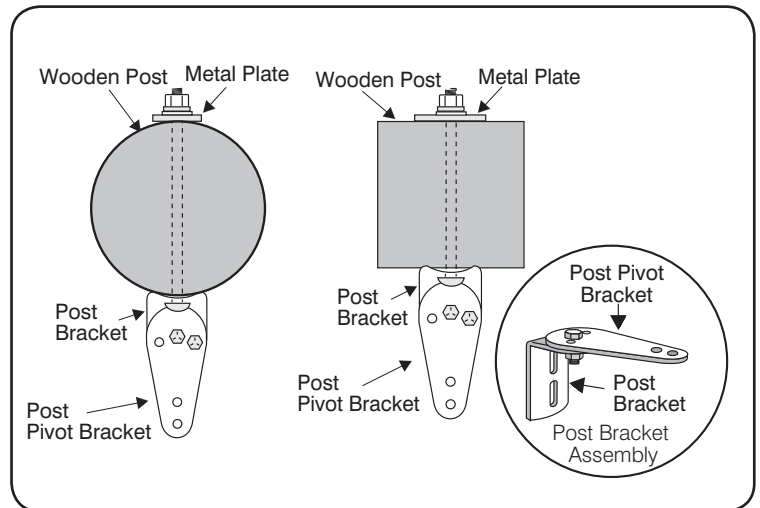

Reinforcing Gates for the Gate Brackets

We *recommend* using a muffler clamp, wood, or metal, to reinforce thin-walled tube gates, or wood to reinforce panel gates as shown. These reinforcement methods will prevent damage to the opener and gate. Additional hardware may be needed depending on the installation.

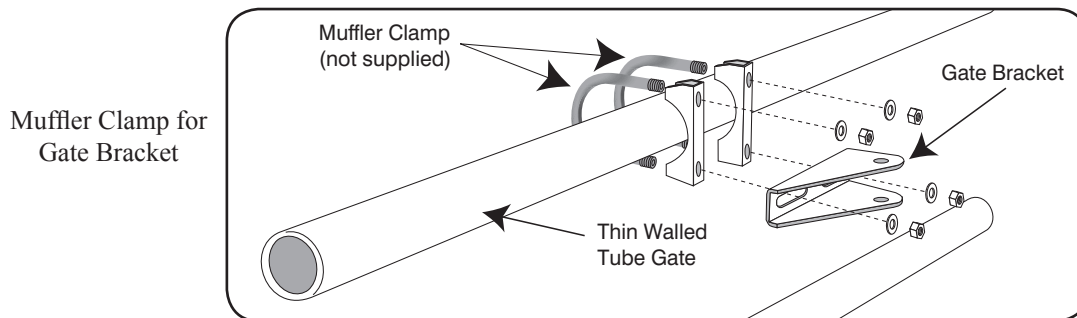

Muffler Clamp for Gate Bracket

Wood or Metal Reinforcement

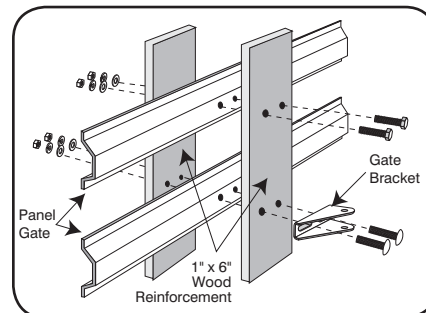
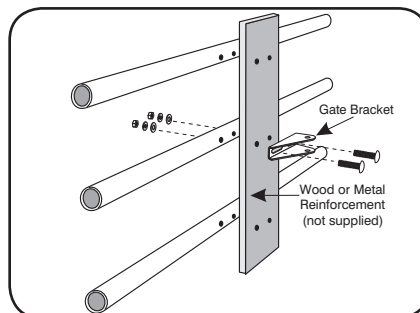

1" x 6" Wood Reinforcement

Install Post Bracket Assembly and Gate Bracket

Step 1

Insert the $\frac{3}{8}$ " x $1\frac{1}{4}$ " bolt through the center hole of the post brackets and post pivot bracket. Secure with a $\frac{3}{8}$ " washer, $\frac{3}{8}$ " lock washer and $\frac{3}{8}$ " nut. **DO NOT overtighten** the nut (the post pivot bracket will have to be adjusted later).

Step 2

Attach post bracket assembly to the rear mount of the opener with a clevis pin. Secure the clevis pin with a hairpin clip.

Step 3

Attach gate bracket to the front mount of the opener with a clevis pin. Secure the clevis pin with a hairpin clip.

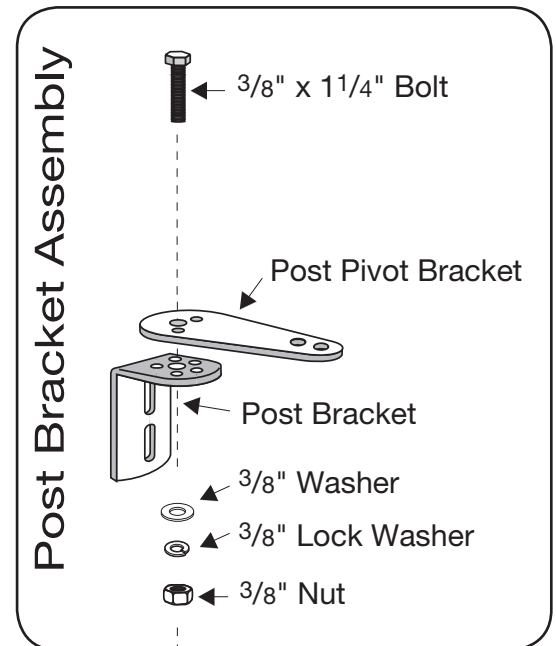
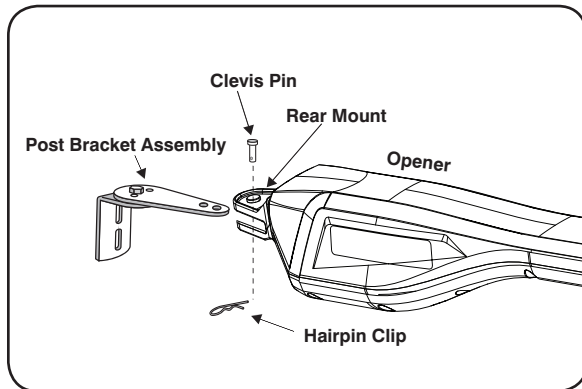

Step 4

With the gate in the **fully open position and the opener arm fully retracted**, adjust the post bracket assembly and gate bracket until the opener is level. While holding the opener level, use C-clamps to temporarily secure the post bracket assembly and gate bracket to the post and gate.

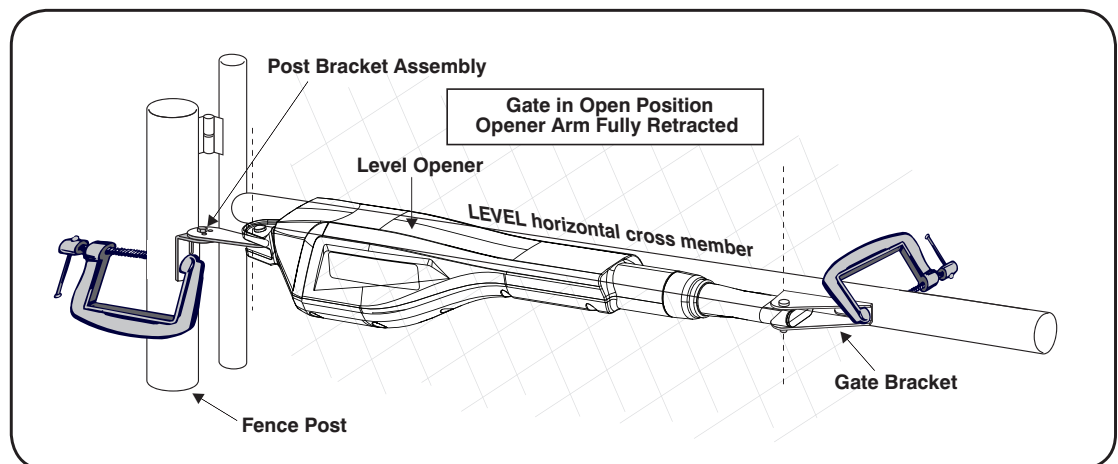
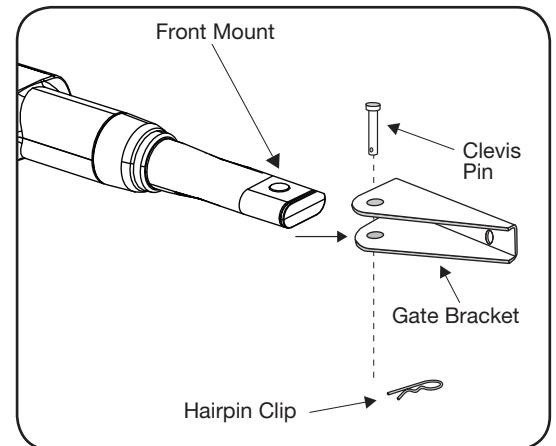

Step 5

Be sure the position of the gate opener and brackets allows for 1" of clearance between the gate and the opener in both the open and closed position, while at the same time maintaining a stroke distance of 7" to 13" from center of hole in the end of the retracted opener arm to the center of the hole in the gate bracket with the gate in the closed position. This mounting position will give the opener the most efficient leverage point for operation and provides the least possible pinch area.

Step 6

After verifying that you have the best position for the post pivot bracket in the open position, insert the 5/16" x 1 1/4" bolt through the aligned holes of the post bracket and post pivot bracket to hold it in place. Remove the clevis pin from the front mount and **while supporting the gate opener**, swing the gate and gate opener to the *closed* position. Again, check the clearance and be sure that the gate opener is not binding at the post pivot bracket.

If you don't have the required clearance, or if the gate opener is binding on the post pivot bracket, remove the 5/16" x 1 1/4" bolt and readjust the post pivot bracket. Reinstall the bolt and related hardware as shown in the diagram to the right.

TIP: Turn the post pivot bracket over for more hole alignment options. You can also move the entire post bracket assembly to different positions on the post. If you are mounting to a post or column larger than 8" or you can not achieve the mentioned clearances, you can:

- 1) eliminate the post pivot to try and achieve the proper clearances.
- 2) install the unit as a push to open (bracket not included).
- 3) re-hang the gate within 4" inches of the back corner of the column.

NOTE: Re-hanging the gate, depending on the construction of a column, may require additional expertise and tools/materials.

Step 7

When the post bracket assembly is in the optimum position, reattach the opener to the gate bracket (gate in the open position); recheck the gate opener level; make sure the brackets are clamped securely.

Step 8

Mark reference points for bolt holes on the post through middle of post bracket assembly slots. Mark reference points for bolt holes on the gate cross member through middle of gate bracket slots. After marking your reference points, remove the opener and brackets from the fence and gate.

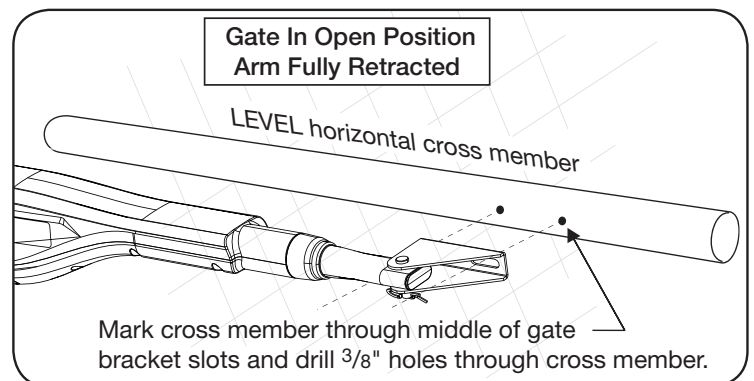
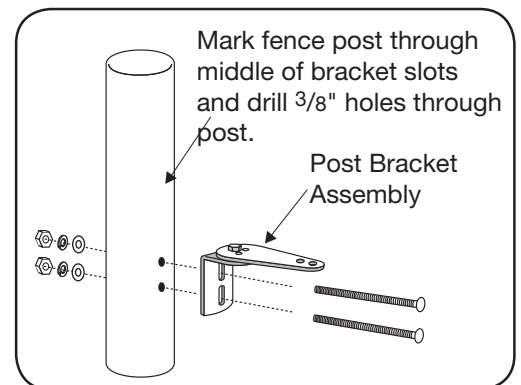
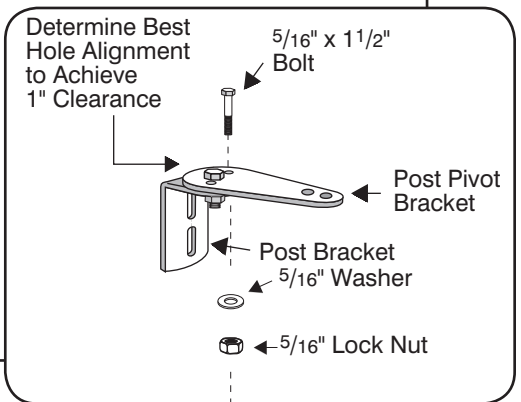
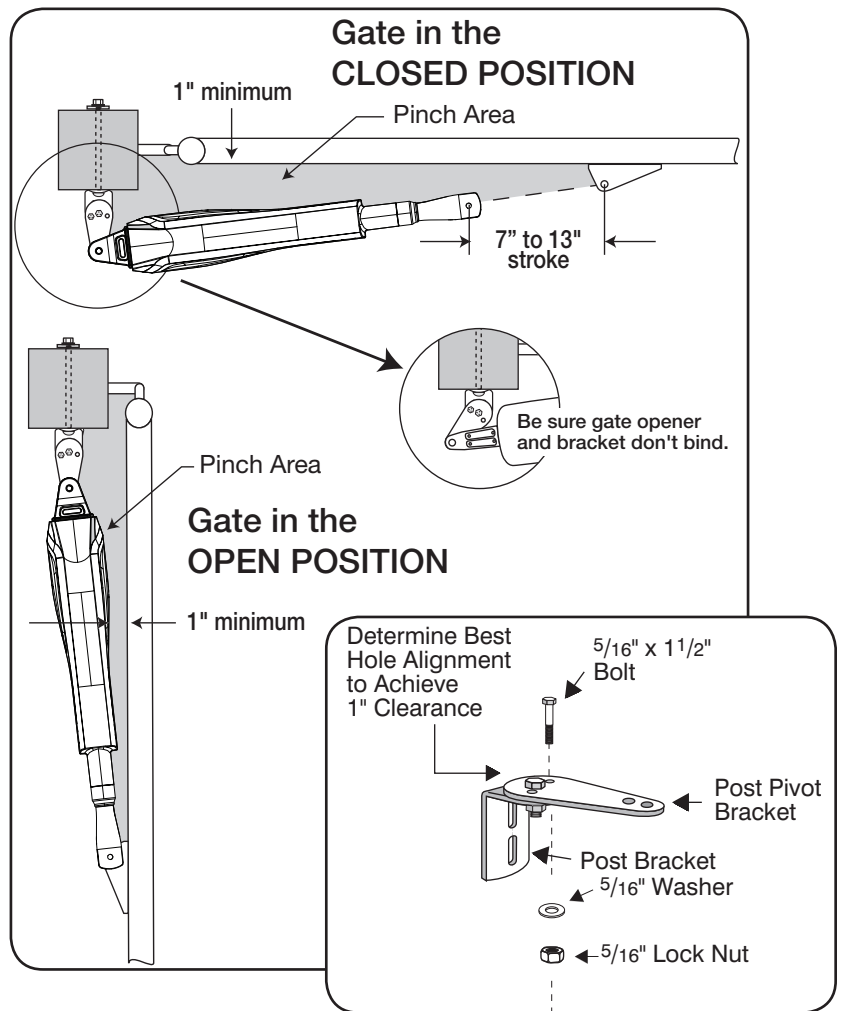

Step 9

Drill $\frac{3}{8}$ " holes through post as marked. Fasten post bracket assembly to the fence post using two $\frac{3}{8}$ " x 8" bolts, washers, lock washers and nuts. **You must use bolts that completely penetrate the post.**

Step 10

Drill $\frac{3}{8}$ " holes through the gate cross member as marked. Mount gate bracket using two $\frac{3}{8}$ " x 2 $\frac{3}{4}$ " bolts, washers, lock washers and nuts.

NOTE: **After** the gate opener installation is **complete** and operation of **the opener system has been tested**, you should remove excess bolt length extending beyond the tightened nuts with a hacksaw or bolt cutters.

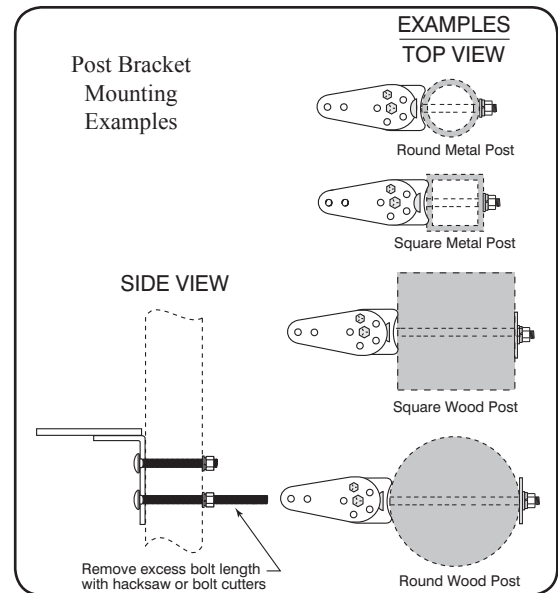

Gate Bracket Mounting Examples

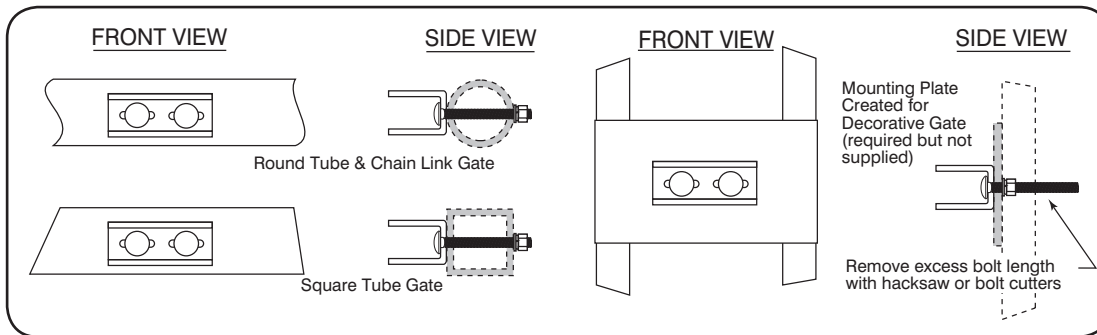

Attach Opener Arm

Step 1

Attach the opener to the securely bolted post bracket assembly and gate bracket using clevis pins, bushings, and hairpin clips, or optional Pin Lock [FM133] ([page 26](#)). Verify that the opener is level and adjust the post bracket assembly, if necessary.

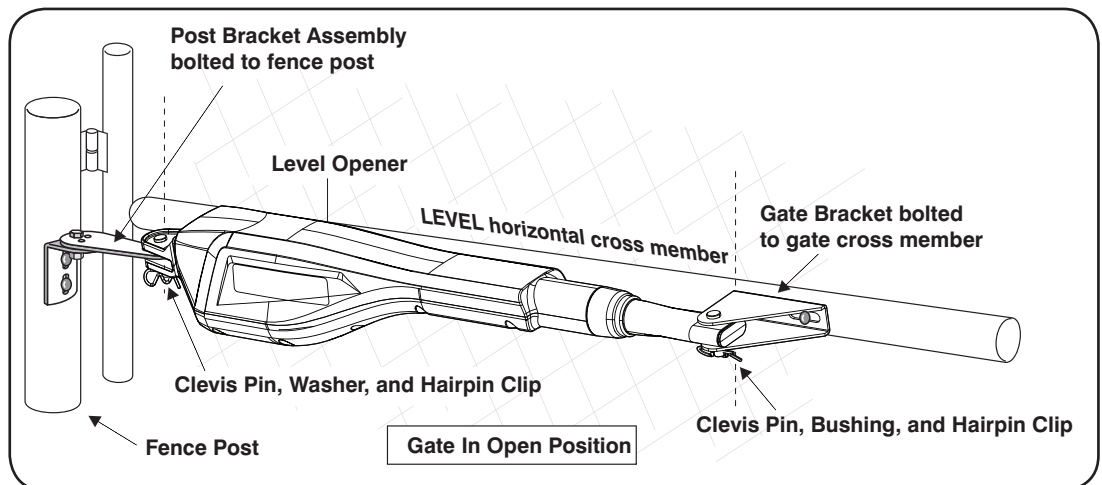

Step 2

Install the SECOND gate opener and hardware on the second gate following the same procedures as the FIRST gate opener and hardware ("Installing Post Bracket Assembly and Gate Bracket" Steps 1–10).

NOTE: The power cable for the Second Opener should be run in PVC conduit under the driveway to protect it from damage due to lawn mowers, heavy equipment, etc. (See illustration on [page 6](#).) NEVER SPLICE opener arm power cables. This will cause performance problems and may damage the opener.

Install the Closed Position Stop Plates

The closed position stop plate is attached to the FIRST gate to help stabilize the gate leaf in the closed position. An optional low profile ground stop, when used with the closed position stop plate, provides a secure point for the SECOND gate to close against. To further enhance the stability and security of your gate, install a Mighty Mule Automatic Gate Lock [FM143] [page 26](#)). If you will be using the Mighty Mule Gate Lock with your gate opener system, the closed position ground stop is *required*.

**For Pull-to-Open systems, install the closed position stop plates on the *inside* of the gates.
For Push-to-Open systems, install the closed position stop plates on the *outside* of the gates.**

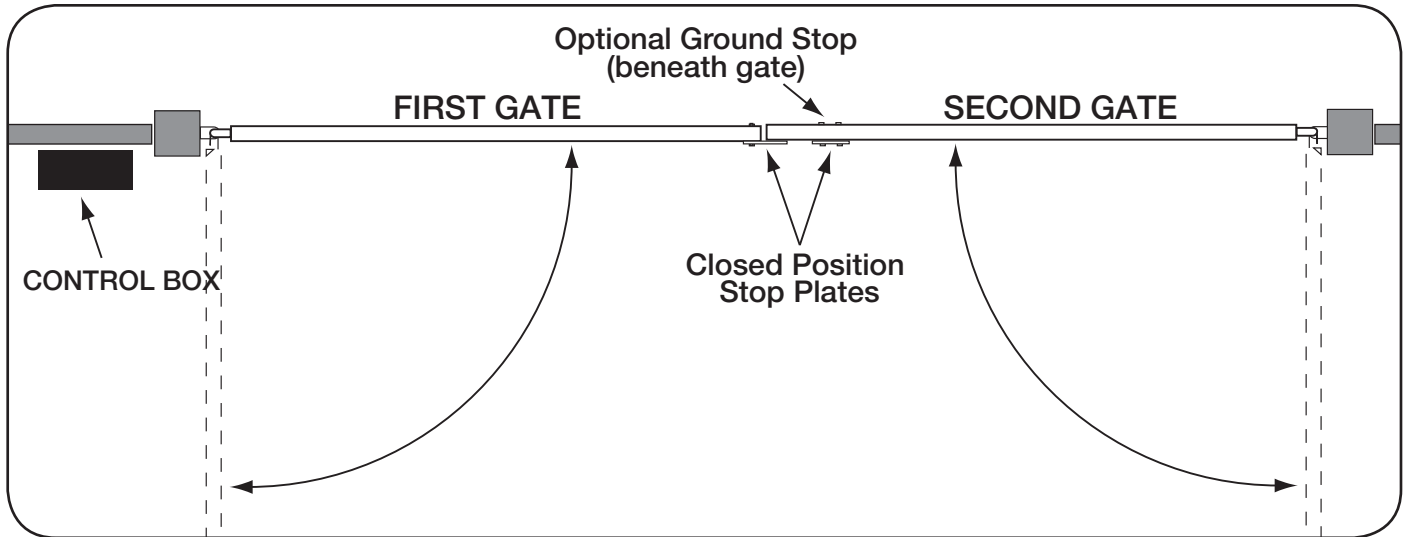

Step 1

Detach the gate opener arms from the gates and move the gates to the closed position.

Step 2

Using appropriate hardware for your type of gate (U-bolts for tube or chain link; screw or bolts for wood or metal) attach the closed position stop plate (horizontally) about mid-height on the FIRST gate frame. Do not tighten it completely at this time. Slide the stop plate toward the frame of the SECOND gate leaf until they touch. Once you have moved the stop plate to the correct position, tighten its hardware completely.

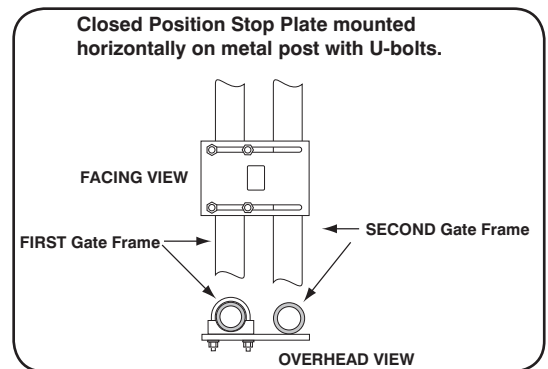

Step 3

The low profile ground stop may be made of metal or concrete and should be firmly secured in the ground. The low profile ground stop should be installed beneath the SECOND gate, positioned near the leading edge.

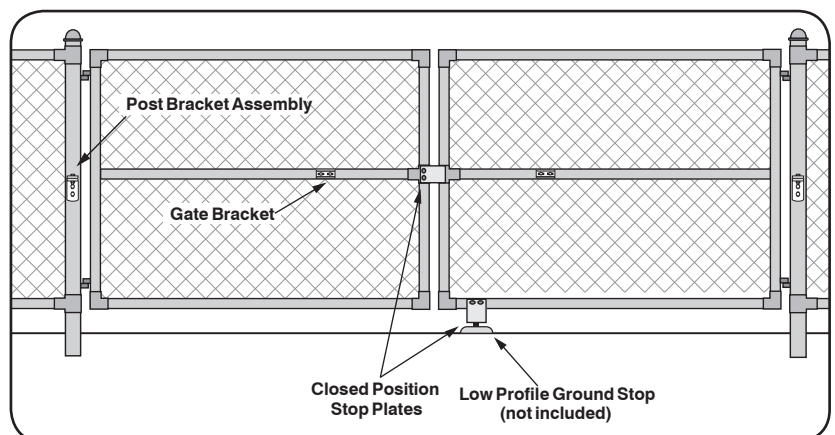

Step 4

Using appropriate hardware for your type of gate, attach the vertical closed position stop plate to the **SECOND** gate frame at the point where it will come in contact with the low profile ground stop. Do not tighten it completely at this time. You must slide the closed position stop plate toward the low profile ground stop until they touch. Once you have moved the stop plate to the correct position, tighten its hardware completely.

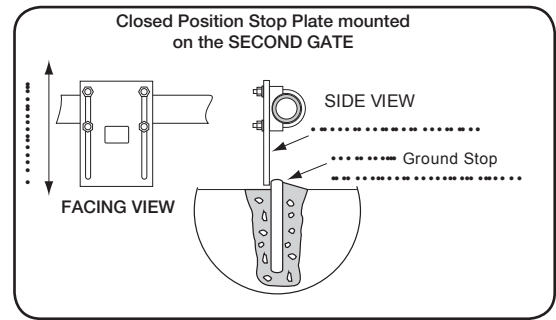

Step 5

Return the gates to their open positions and reattach the gate openers to the gates.

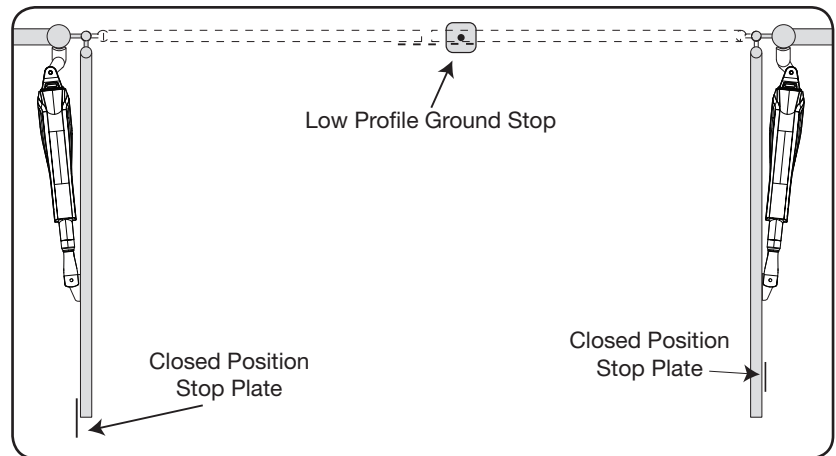

Mount the Control Box

Step 1

Mount the control box using the screws (provided) or another secure mounting method. The control box must be mounted at least 3 feet above the ground to protect it from rain splash, snow, etc., and at least 3 feet from an AC power source to prevent electrical interference.

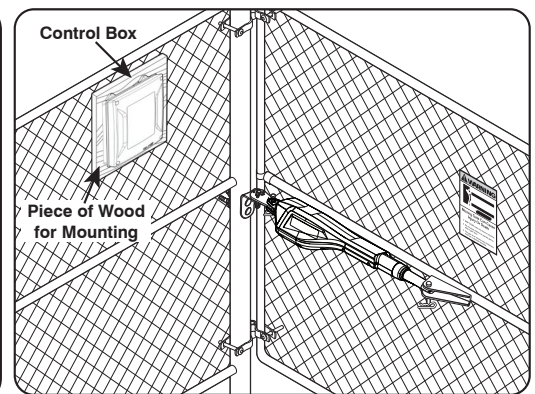
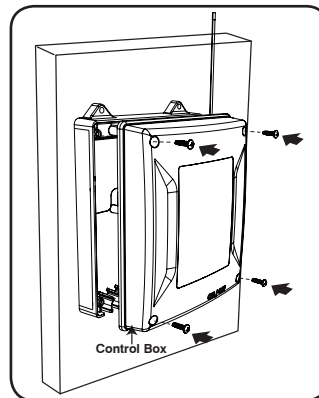

Step 2

Remove the control box cover by removing the four (4) screws.

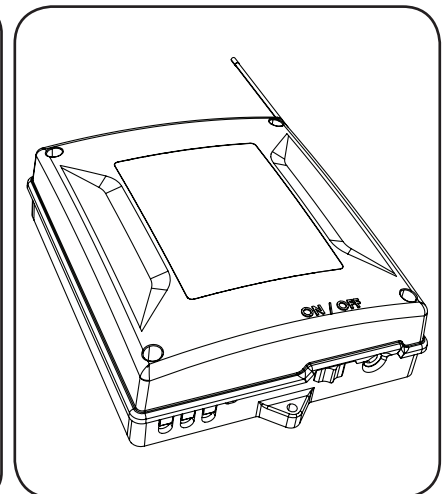
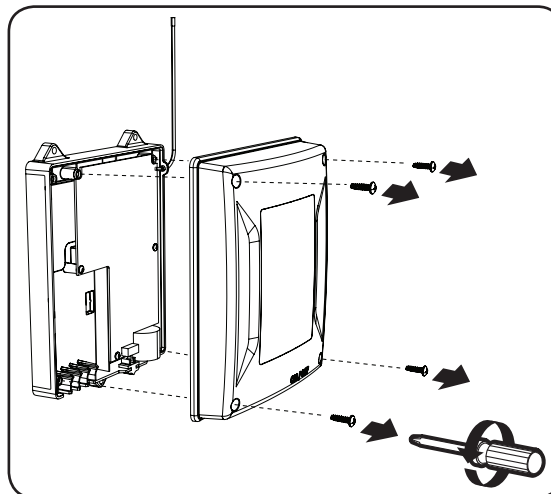

Connect Opener Power Cables

Step 1

Bring **FIRST** power cable into the control box through a strain relief slot, leaving enough wire to reach the **FIRST OPR.** terminal block (white to WHT; green to GRN; red to RED; black to BLK). Insert the individual power cable wires into appropriate terminals on the **FIRST OPR.** terminal block. Tighten the set screws. A dab of petroleum jelly on each terminal will help prevent corrosion.

Step 2

Pull the 36' second opener power cable through the PVC conduit and secure in the driveway slot/trench (see pages 6 and 14).

Step 3

Insert the **SECOND** power cable into a strain relief slot. Bring power cable into the control box through a strain relief slot, leaving enough wire to reach the **SECOND OPR.** terminal block.

Insert the individual power cable wires into appropriate terminals on the **SECOND OPR.** terminal block (white to WHT; green to GRN; red to RED; black to BLK). Tighten the set screws. A dab of petroleum jelly on each terminal will help prevent corrosion.

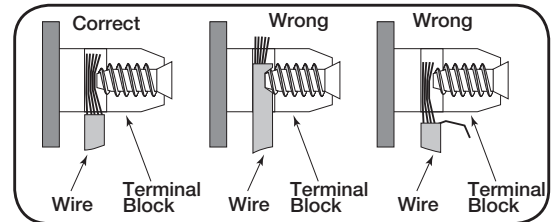
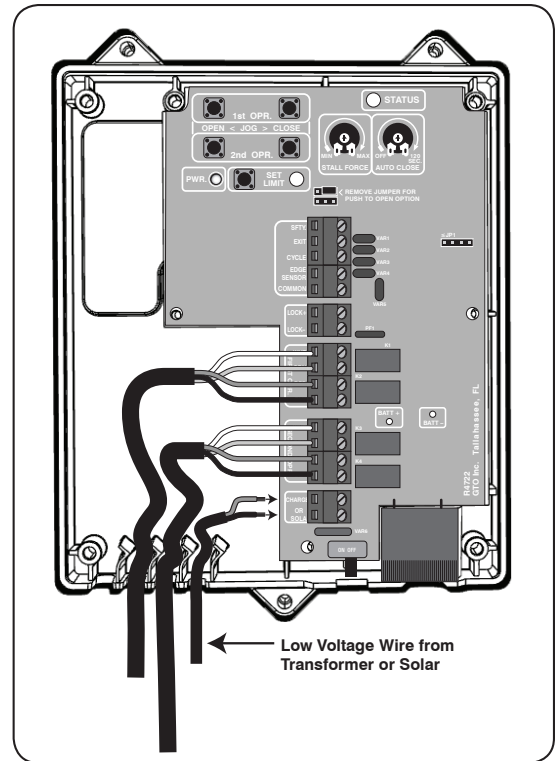

Connect the Transformer

(*Solar Instructions on [Page 21](#))

NEVER USE TRANSFORMER AND SOLAR PANEL(S) AT THE SAME TIME!

IMPORTANT INFORMATION ABOUT LOW VOLTAGE WIRE:

- The only wire acceptable for use with NSC products is 16 gauge multi-stranded, low voltage, direct burial wire. This particular gauge enables the transformer to provide an adequate charge through the control board to the battery at distances up to 1000'.
- **DO NOT** use telephone wire or solid core wire. Unlike multi-stranded wire, these types of wire are inadequate for use with your gate opener system.
- **NEVER** splice wires together. Splicing permits corrosion and seriously degrades the wire's ability to carry an adequate current.

Step 1

Make sure the power switch is OFF.

Step 2

Select the electrical outlet where you will plug the transformer. Measure the distance from this outlet to the control box following the path where the wire will be laid. After you have measured how much wire is needed, cut the wire to the appropriate length (up to 1000').

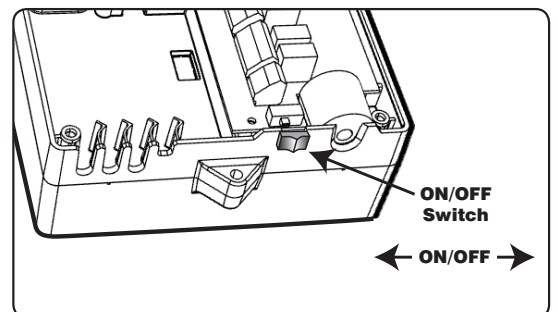

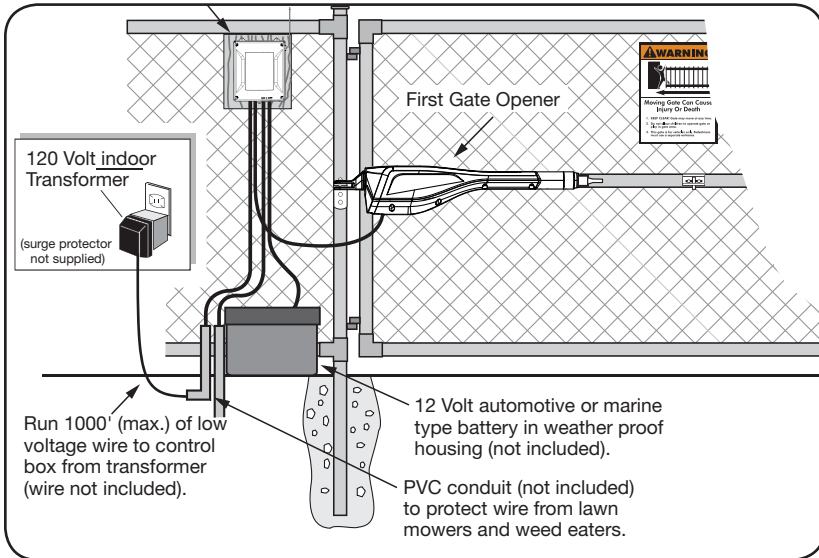

Step 3

Lay the measured length of low voltage wire in a trench following a path from the selected electrical outlet to the control box. Wires coming up from the ground should be run through PVC conduit to protect them from lawn mower blades, weed eaters, and grazing animals. Be sure to bury the wire laid in the trench.

Step 4

Bring enough wire up through the PVC conduit to reach the control board.

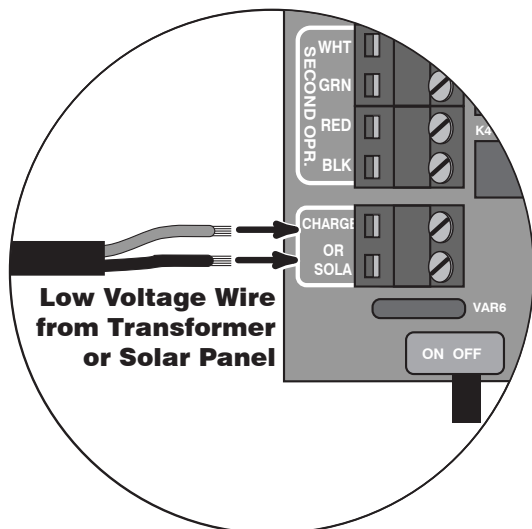
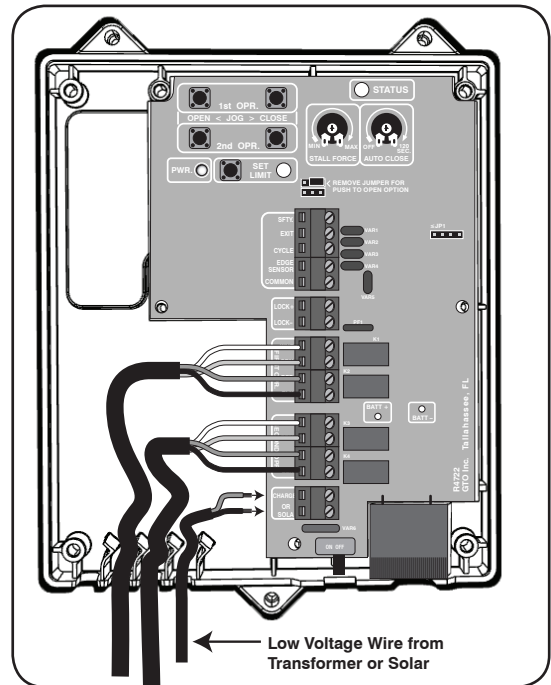

Step 5

Strip 3/16" off the ends of the low voltage wire and twist tightly. Attach these ends to the 16VDC OR SOLAR terminals located on the terminal block). Be certain not to let the exposed wires touch each other!

Insert one transformer wire into a 16VDC OR SOLAR terminal. Insert the other transformer wire into the remaining 16VDC OR SOLAR terminal. The transformer wires can be connected to the 16VDC OR SOLAR terminals regardless of color/polarity.

Tighten set screws against exposed end of wires. A dab of household petroleum jelly on each terminal will help prevent corrosion.

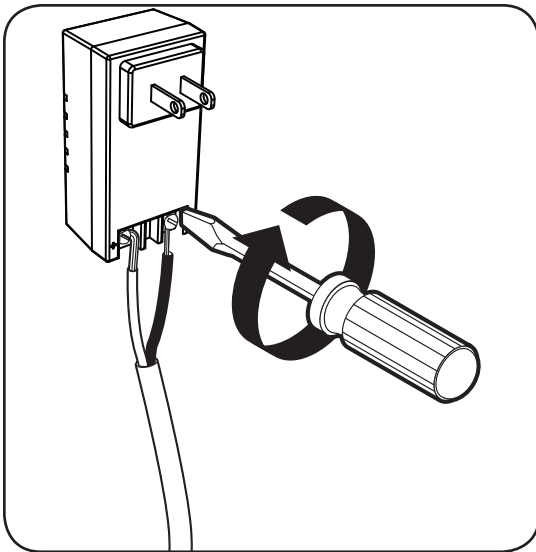

Step 6

At the AC outlet, strip 1/2" of insulation from the ends of the low voltage wire. Attach these stripped ends to the transformer terminals. A dab of household petroleum jelly on each terminal will help prevent corrosion. We suggest adding crimp on fork lugs to the end of each wire before attaching it to the transformer.

Make sure the exposed wires do not touch each other!

Connect Battery Harness to Control Board

Step 1

Make sure control box is OFF. Locate the BATTERY wires from the CONTROL BOARD marked BATT + and BATT -.

Step 2

Run the battery harness wires into the control box through a strain relief slot, leaving enough wire to reach the battery wire plugs.

Step 3

Plug the BLACK battery harness wire into the BLACK wire (BATT - terminal), and the RED battery harness wire to the RED wire (BATT + terminal). Wire correctly; **reverse connection will damage control board.**

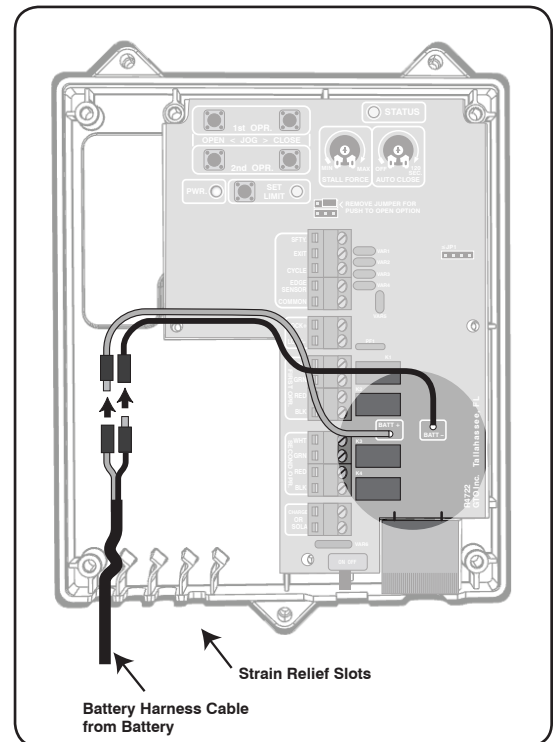

Connect the Battery

Step 1

Place the 12 Volt automotive/lawn tractor or marine battery and its weatherproof case within 6 feet of where the control box is mounted.

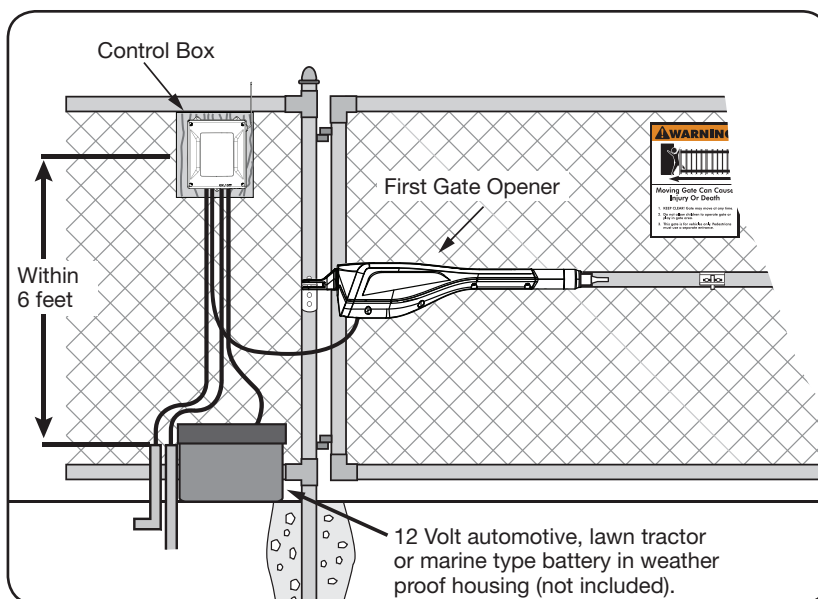
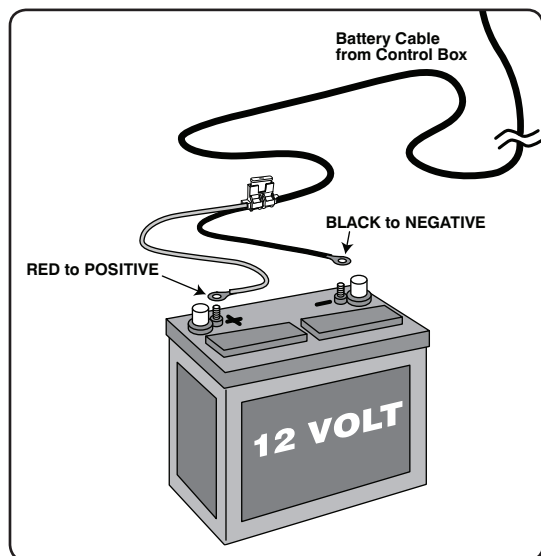

Step 2

Attach the battery wires provided to the terminals of the battery. Take care to attach the BLACK wire to the NEGATIVE terminal and the RED wire to the POSITIVE terminal. **Reverse connection will cause damage to the control board.**

NOTE: for solar installation go to [page 21](#) then return to next section on Setting the CLOSED Position Limit.

Step 3

Plug the transformer into the electrical outlet. Use of a surge protector with the transformer is **strongly** recommended. If electrical outlet is located outdoors, outlet and transformer should be protected by a weatherproof cover.

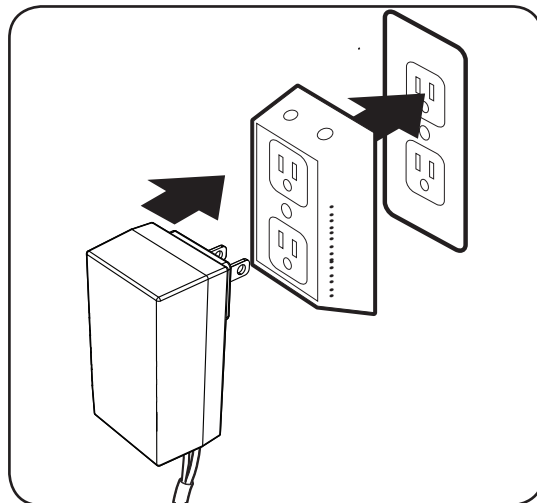

Set the CLOSED Position Limit for PULL-TO-OPEN Installation

Your transmitter must be able to operate the gate. If not see, "Personalize Your Transmitter Setting on [page 18](#).

Note: The OPEN limit is when the opener is fully retracted and the gate is in the full open position. The open limit setting can only be adjusted by moving the gate bracket. To achieve the optimum closed position, you must adjust the CLOSED limit setting:

Step 1

Make sure the Control Box switch is ON and that the gate is in the OPEN POSITION (arms fully retracted).

Step 2

Press and HOLD the 2nd opener JOG CLOSE button on the control board and be prepared to RELEASE the button when the gate reaches the desired closed position/limit. Use the JOG OPEN and CLOSE buttons to "fine tune" the gate position if necessary.

Step 3

Press and HOLD the 1st opener JOG CLOSE button on the control board and be prepared to RELEASE the button when the gate reaches the desired closed position/limit. Use the JOG OPEN and CLOSE buttons to "fine tune" the gate position if necessary.

Step 4

With the gates in the desired closed positions PRESS and HOLD the SET LIMIT button until the alarm and RED Light come on. Then release the button.

NOTE: The opener must be extended more than 7 inches to set limits.

Step 5

NOTE: When the control box cover is removed the receiver range is reduced to less than 5 feet.

Press the transmitter button once (within 5 feet of the control board) and allow the gates to fully open. The alarm will beep once when both gates reach the OPEN LIMIT. This indicates the limits for both arms are programmed in memory.

Step 6

Press the transmitter button and allow the gates to fully close to verify that they stop at the desired positions. Repeat Steps 2-5 if correction is needed.

NOTE: If the gate stops and reverses you may need to adjust the Stall Force (see below).

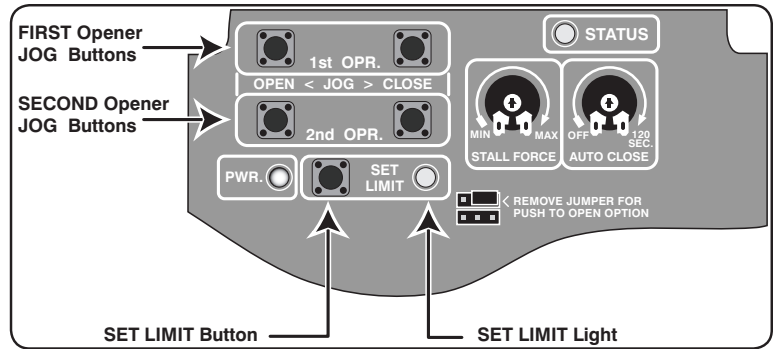

CAUTION

For safety reasons the Dual Sense Stall Force setting on the Mighty Mule control board comes from the factory set to the 10 o'clock position. This setting may need adjustment depending on the size and weight of the gate.

ALWAYS KEEP SAFETY AT THE TOP OF YOUR LIST WHEN ADJUSTING OR SERVICING YOUR GATE SYSTEM.

Setting Dual Sense Detection and Auto Close Timer

Do not use the Dual Sense Stall Force adjustment to compensate for a gate that is sticking or binding. Excessive Stall Force may cause damage to the gate operator or gate system or Injury or Death.

The Stall Force adjustment controls the amount of force the opener will apply against an obstruction before it stops and reverses direction. The adjustment on the control board operates like a volume control on a radio. It controls the amount of force the opener will apply to an obstruction before it automatically reverses direction.

The Stall Force adjustment is located on the control board. Turn the "STALL FORCE" arrow in the center of the potentiometer with small flat head screwdriver. Adjust the sensitivity to the point where the gate operates without obstructing from its own weight or the wind conditions in your area.

NOTE: You may need to increase the stall force in cold weather due to increased resistance from gate hinges. However, the adjustment must remain as near to minimum as possible and when the weather improves decrease the setting to the appropriate position.

Setting Auto-Close Time

The Auto-Close determines how long the gate will remain open before it automatically closes. The factory setting is OFF. Use a small flat blade screwdriver, you can adjust the settings to OFF, or from 3 to 120 seconds.

NOTE: Auto-Close timer is disabled (gate will not automatically close) if gate is not at the fully open position.

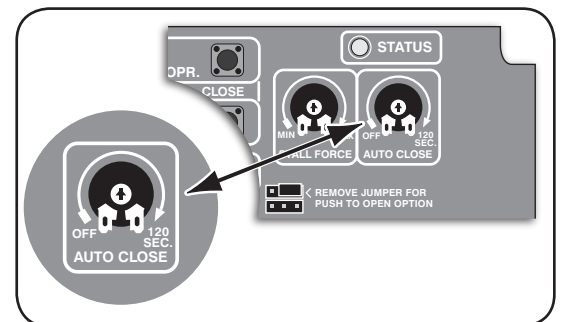
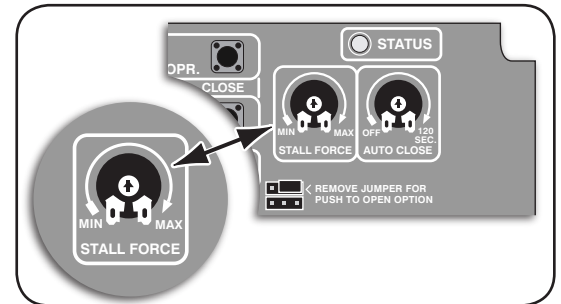

MMT103 Transmitter

Learning the MM103

With system off, press and hold the transmitter button you want to use, then turn on the system and keep holding the button until the system "beeps" once.

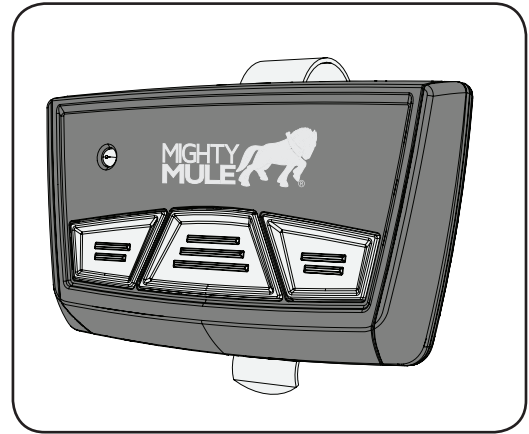

NOTE: For instructions on using the FM134/135 transmitter with this product, refer to www.mightymule.com.

WARNING: Changes, modifications or adjustments not expressly approved by Nortek Security & Control, LLC could void the user's authority to operate this equipment. There Are No User Serviceable Parts.

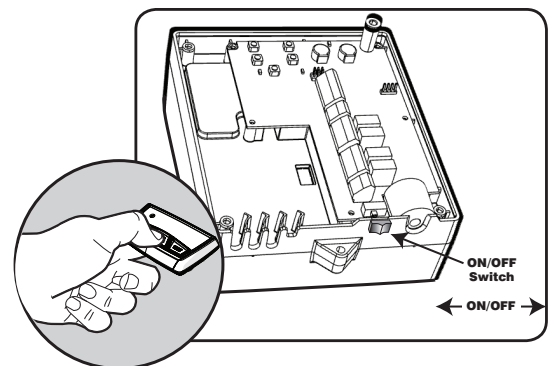

NOTICE: This equipment has been tested and found to comply with the limits for a Class B digital device, pursuant to part 15 the FCC. These limits are designed to provide reasonable protection against harmful interference in a residential installation. This equipment generates, uses and can radiate radio frequency energy and, if not installed and used in accordance with the instructions, may cause harmful interference to radio communications. However, there is no guarantee that interference will not occur in a particular installation. If this equipment does cause harmful interference to radio or television reception, which can be determined by turning the equipment off and on, the user is encouraged to try to correct the interference by one or more of the following measures:

- Reorient or relocate the receiving antenna.
- Increase the separation between the equipment and receiver.
- Connect the equipment into an outlet on a circuit different from that to which the receiver is connected.
- Consult the dealer or an experienced radio/TV technician for help.

This device complies with Part 15 of the FCC Rules. Operation is subject to the following two conditions: (1) This device may not cause harmful interference, and (2) this device must accept any interference received, including interference that may cause undesired operation.

Push-To-Open Installation Instructions

PUSH-TO-OPEN gates open out from the property (opener arms *extend* to open). Push-To-Open Brackets are required for this type of installation, one for each gate [FM148] [page 27](#)). In a Push-To-Open installation, the opener is installed while the gate is **in the closed position and the opener fully retracted**. **Swinging gates MUST NEVER open into public access areas!**

Step 1: Read "Installation of the First Opener" on [page 7](#).

Step 2: Determining The Mounting Position of The Post Bracket Assembly

- A. Insert the $\frac{3}{8}$ " x $1\frac{1}{4}$ " bolt through the center hole of the post brackets and post pivot bracket. Secure with a $\frac{3}{8}$ " washer, lock washer and $\frac{3}{8}$ " nut. **DO NOT overtighten** the nut (the post pivot bracket will have to be adjusted later). Attach post bracket assembly to the rear mount of the opener with a clevis pin. Secure the clevis pin with a hairpin clip. Attach gate bracket to the front mount of the opener with a clevis pin. Secure the clevis pin with a hairpin clip. For pictorial reference see Steps 1, 2 and 3 on [page 8](#).

- B. With the gate in the closed position (up to 110° from its open position), and the opener fully retracted, adjust the post bracket assembly and gate bracket until the opener is level. While holding the opener level, use C-clamps to temporarily keep the post bracket assembly and gate bracket in their respective positions on the fence post and gate. For pictorial reference see Steps 3 on [page 8](#).

IMPORTANT: Be sure the position of the gate opener and brackets allows for 1" of clearance between the gate and the opener in both the open and closed position, while at the same time maintaining a stroke distance of 7" to 13" from center of hole in the end of the retracted opener arm to the center of the hole in the gate bracket with the gate in the open position. This mounting position will give the opener the most efficient leverage point for operation and provides the least possible pinch area.

- C. After verifying that you have the best position for the post pivot bracket in the closed position, insert the $\frac{5}{16}$ " x $1\frac{1}{4}$ " bolt through the aligned holes of the post bracket and post pivot bracket to hold it in place. Remove the clevis pin from the front mount and **while supporting the gate opener**, swing the gate and gate opener to the *open* position. Again, check the clearance and be sure that the gate opener is not binding.

IMPORTANT: If you don't have the required clearance, or if the gate opener is binding, remove the $\frac{5}{16}$ " x $1\frac{1}{4}$ " bolt and readjust the post pivot bracket. **TIP:** Turn the post pivot bracket over for more hole alignment options.

- D. When the post pivot bracket assembly is in the optimum position, reattach the opener to the gate bracket (gate in the closed position); recheck the gate opener level; make sure the brackets are clamped securely. Mark reference points for bolt holes on the post through middle of post bracket slots. Mark reference points for bolt holes on the gate cross member through middle of gate bracket slots. After marking your reference points, remove the opener and brackets from the post and gate.

- E. Drill $\frac{3}{8}$ " holes through post as marked. Fasten post bracket assembly to the post using two $\frac{3}{8}$ " x 8" bolts, washers, lock washers and nuts. **You must use bolts that completely penetrate the post.** Drill $\frac{3}{8}$ " holes through the gate cross member as marked. Mount gate bracket using two $\frac{3}{8}$ " x $2\frac{3}{4}$ " bolts, washers, lock washers and nuts.

NOTE: For mounting examples, see [page 10](#).

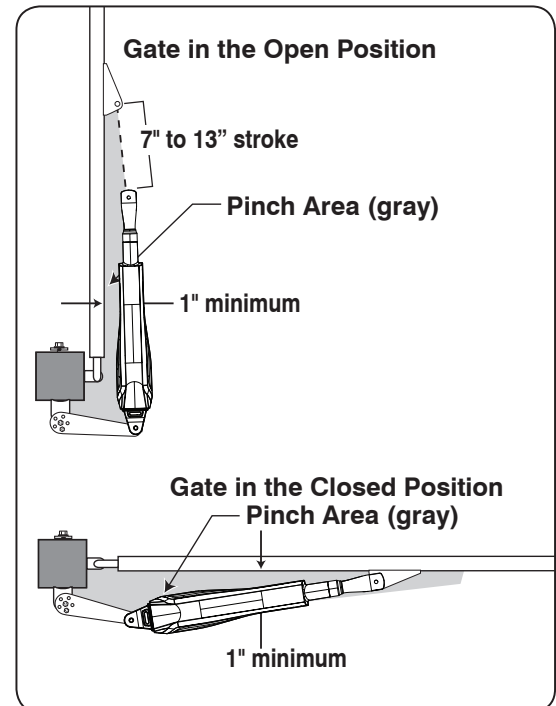
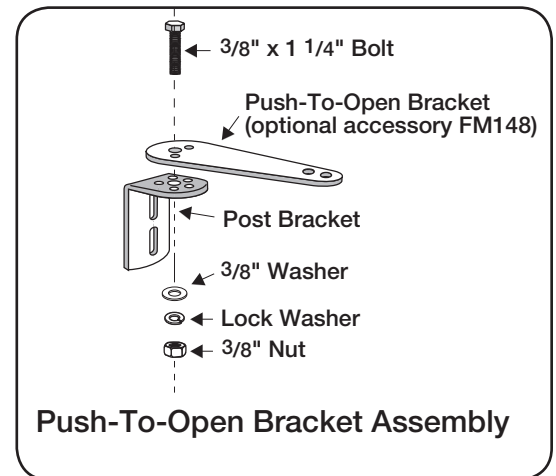

- Step 3: Attach Opener Arm ([page 10](#))
- Step 4: Install Closed Position Stop Plates ([page 11](#))
- Step 5: Mount the Control Box ([page 12](#))
- Step 6: Connect Opener Power Cables ([page 13](#))
- Step 7: Connect the Transformer ([page 13](#)) OR Solar Charger ([page 21](#))
- Step 8: Connect Battery Harness ([page 15](#))
- Step 9: Connect Battery ([page 16](#))
- Step 10: Remove Push-To-Open Jumper

- A. Make sure the control box power switch is OFF.
- B. Use small pliers to move the JUMPER for PUSH-TO-OPEN applications.
- C. Turn power switch ON. The control board is now configured to push the gate open. (Keep the jumper, as it is necessary if there is ever a need to convert the opener for Pull-To-Open).

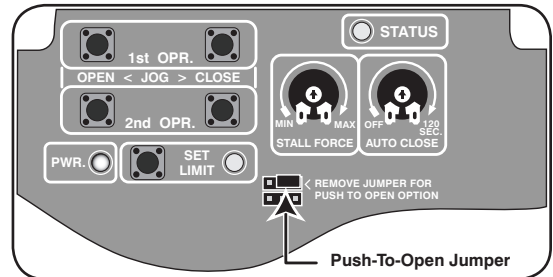

- Step 11: Set the Open Position Limit (Push-to-Open)

NOTE: Must have a transmitter that operates the gate. If not see Personalize Your Transmitter Setting on [page 18](#).

The CLOSED limit is when the opener is fully retracted and the gate is in the closed position. The closed limit setting can only be adjusted by moving the gate bracket. To achieve the optimum open position, you must adjust the OPEN Limit setting:

- A. If not already ON slide the ON/OFF switch on the Control Box to the ON position and make sure the arms are in the CLOSED POSITION (fully retracted).
- B. Press and HOLD the FIRST Opener OPEN button on the control board and be prepared to RELEASE the button when the gates reached the desired open position/limit. Use the JOG OPEN and CLOSE buttons to "fine tune" the gate position if necessary.
- C. Press and HOLD the SECOND Opener OPEN button on the control board and be prepared to RELEASE the button when the gates reached the desired open position/limit. Use the JOG OPEN and CLOSE buttons to "fine tune" the gate position if necessary.
- D. NOTE: The opener arms must be extended more than 7 inches to set limits. With the gates in the desired open positions PRESS and HOLD the SET LIMIT button until the alarm and RED Light come on. Then release the button.
- E. NOTE: When the control box cover is removed the receiver range is reduced to less than 5 feet. Press the transmitter button once and allow the gates to fully close. The alarm will beep once when both gates reach the CLOSED LIMIT. This indicates the LIMITS for both arms are learned and stored in memory.

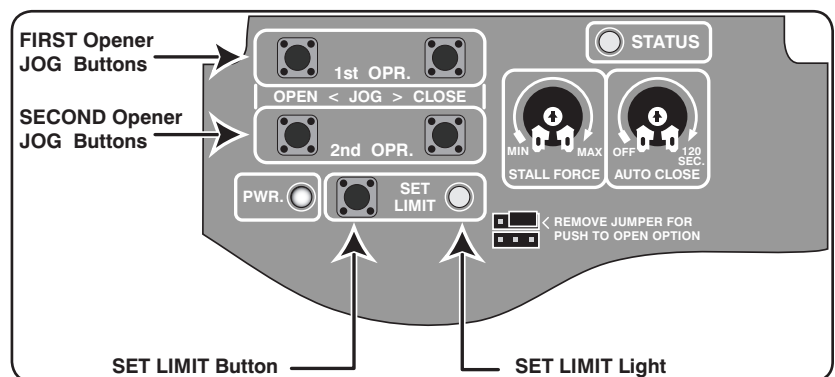

- NOTE: If the gate stops and reverses you may need to adjust the Stall Force (see [page 17](#)).
- F. Press the transmitter button and allow the gates to fully open to verify that they stop at the desired positions. Repeat Steps B – E if correction is needed.

- Step 12: Adjust Stall Force Setting ([page 17](#))
- Step 13: Set Auto Close Time ([page 17](#))
- Step 13: Personalize Transmitter Settings ([page 18](#))

Solar Panel Instructions

**NEVER USE TRANSFORMER AND SOLAR PANEL(S) AT THE SAME TIME!
It will damage the control board!**

IMPORTANT INFORMATION ABOUT LOW VOLTAGE WIRE:

- The only wire acceptable for use with NSC products is 16 gauge multi-stranded, low voltage, PVC sheathed wire. This particular gauge enables the solar panel to provide an adequate charge through the control board to the battery at distances up to 250'.
- DO NOT use telephone wire or solid core wire. Unlike multi-stranded wire, these types of wire are inadequate for use with your gate opener system.

Step 1

Make sure the power switch is OFF.

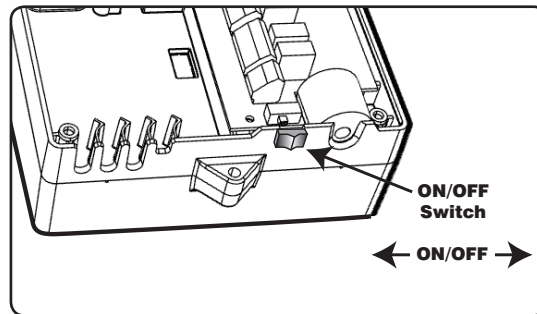

Step 2

Strip 3/16" off the ends of the low voltage wire and twist tightly. Attach these ends to the 16VDC OR SOLAR terminals located on the terminal block. Be certain not to let the exposed wires touch each other!

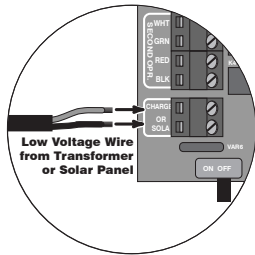

Step 2

Insert one solar panel wire into a 16VDC OR SOLAR terminal. Insert the other solar panel wire into the remaining 16VDC OR SOLAR terminal. The wires can be connected to the 16VDC OR SOLAR terminals regardless of color/polarity.

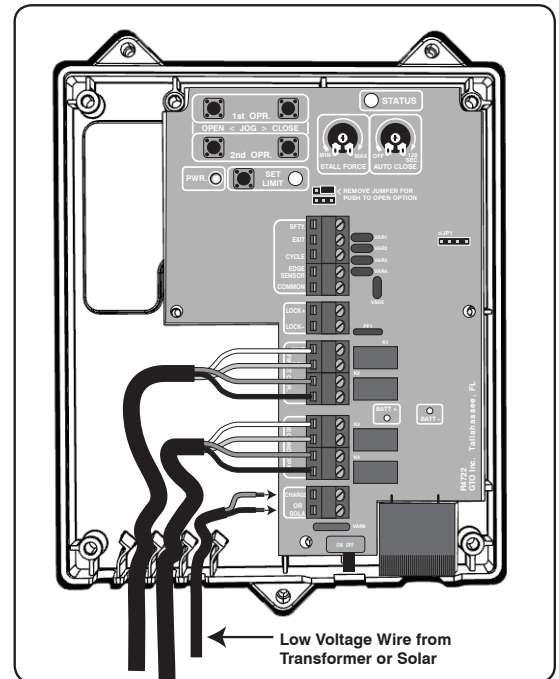

Step 3

Tighten set screws against exposed end of wires. A dab of household petroleum jelly on each terminal will help prevent corrosion.

NOTE: For multiple panels wire the panels in parallel as shown in this diagram.

After connecting the solar panel(s) connect the battery as shown on [page 15](#).

Solar Panels connect in PARALLEL

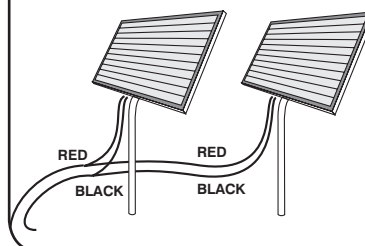

Connecting Additional Devices

Mighty Mule strongly recommends the use of additional obstruction detection devices however we do not endorse any specific brand names. Only use products that are listed to be in compliance with any applicable UL safety standards and national and regional codes.

PLEASE NOTE: Contact sensors, non-contact sensors, shadow loops, etc. are not included with the Mighty Mule. Refer to the sensor manufacturer's instructions for information about installing accessory devices.

The Mighty Mule ONLY accepts accessory devices with normally open dry contact outputs.

! WARNING

Make sure the operator power switch is turned OFF before connecting ANY device wiring to the terminals of the controller. Unplugging the transformer does not turn power to the operator off.

Step 1

Turn control box OFF before connecting safety device wires to the control board. (Unplugging the transformer does not turn power to the opener OFF.)

Step 2

Run wires from safety devices and other accessories through the strain relief openings in the bottom of the control box.

Step 3:

Follow directions in Accessory Installation Manuals.

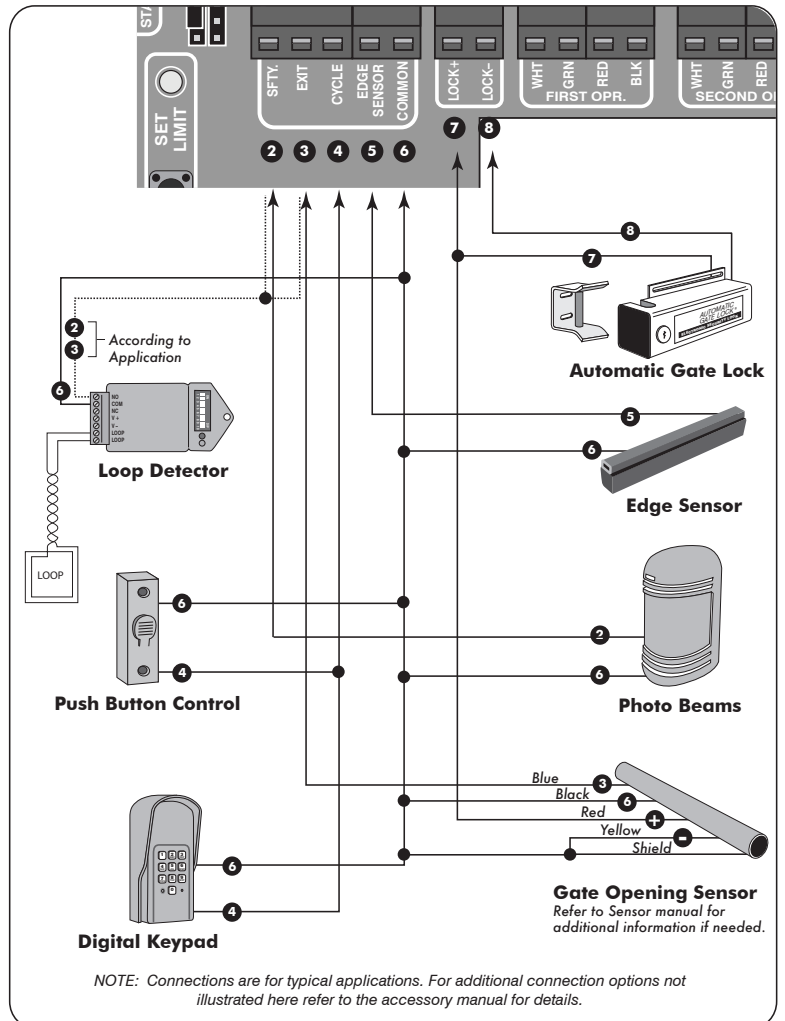
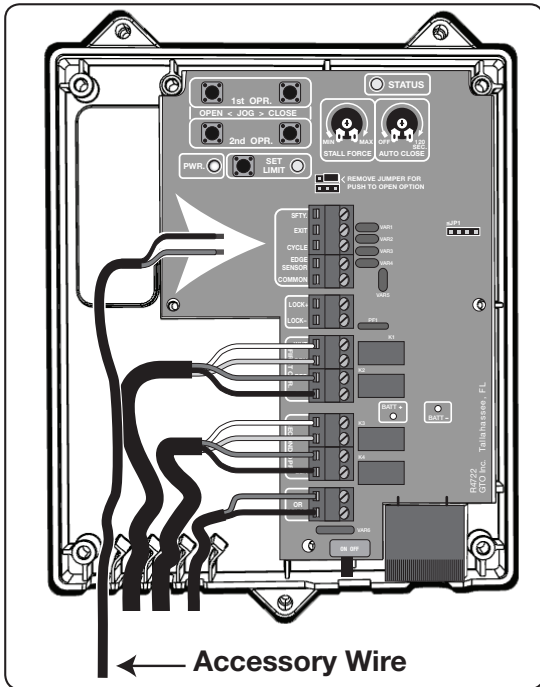

Accessory Inputs

- 1 **SAFETY:** Typically for use with photo beam device, loop detector or other non-contact sensors
 - Activation of this input while the gate is closing will cause the gate to stop and return to the opened position.
 - Activation of this input while the gate is opening has no effect. (gate will continue to open)
 - Activation of this input while gate is idle will prevent gate from closing.
 - Activation of this input while at open limit will restart the auto close time (if enabled).
- 2 **EXIT:** Typically for use with exit loop or wand
 - Activation of this input will open the gate if it's not already at the open position.
 - Activation of this input while at open limit will restart the auto close time (if enabled).
 - Activation of this input while gate is idle will prevent gate from closing.
- 3 **CYCLE:** Typically for use with doorbell button or hard wired keypad
 - Each activation at this input will cycle the operation as follows:
... OPEN STOP CLOSE STOP OPEN ...
- 4 **EDGE:** Typically for use with contact edge sensor
 - Activation of this input while gate is moving will cause it to reverse direction for 2 seconds.
 - Activation of this input while idle will prevent gate from running.
- 5 **COM:** Common/Negative terminal for accessory devices.

12 Volt Power (Maximum Current: 100 mA)

- 5 **COM:** Common/Negative terminal for accessory power source.
- 6 **LOCK +:** Power source for NSC/Mighty Mule accessories, i.e. Gate Opening Sensor [FM138].

Lock Outputs

- 6 **LOCK +:** Positive terminal to connect Automatic Gate Lock [FM143].
- 7 **LOCK -:** Negative terminal to connect Automatic Gate Lock.

Charge Power Inputs

- 8 **CHGR: Power Input Terminals:**
 - Input terminals for transformer or solar panel.
 - Non-polarity sensitive.

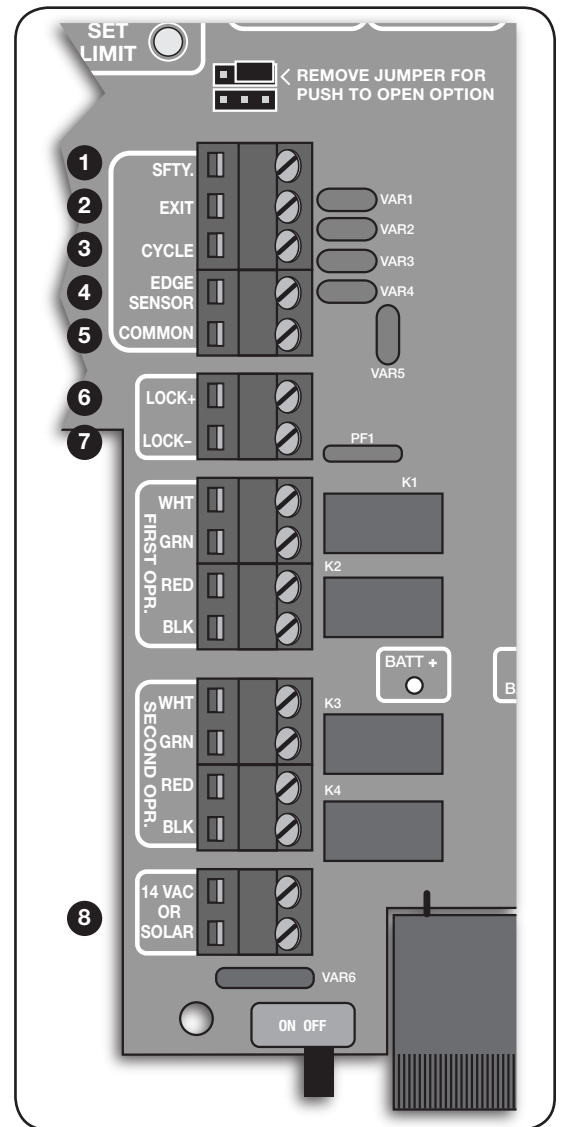

Troubleshooting Guide



If your gate opener does not function properly, use this guide or use the online troubleshooter located at www.mightymule.com before calling the NSC Service Department.

VISUAL AND AUDIBLE DIAGNOSTIC INDICATORS

1. Visual Indicators:

a. Power LED (Green):

- ON: AC power or Solar power is present.
- OFF: There is no input power.

2. AUDIBLE INDICATOR (ALARM/BUZZER):

a. Beeps upon power up:

- This is normal self test when the unit is turned on.

b. Continuous beep after power up:

- Check for a stuck button on a transmitter.

c. Continuous alarm after activation or activation attempt:

- Unit has encountered two (2) obstructions without reaching either limit. (Power cycle to reset the alarm)
- Alarm will automatically shut off after 5 minutes; gate will remain disabled until control box is restarted.

d. 1 beep every 20 seconds:

- Low battery is detected.

e. 1 beep every 2 seconds:

- Position sensor on first opener is open circuit. Call NSC Service department.

f. 2 beeps every 2 seconds:

- Position sensor on second opener is short circuit. Call NSC Service department.

g. 1 beep when attempting to activate the opener:

- Blown fuse.
- Battery is extremely low or damaged.
- Loose connection from battery to circuit board.

h. 3 beeps every 2 seconds (first opener):

- Position sensor is short circuit.
- Call Mighty Mule Service department.

i. 4 beeps every 2 seconds (second opener):

- Position sensor is short circuit.
- Call Mighty Mule Service department.

3. IF THE GATE STOPS AND REVERSES DIRECTION

1. Check the position of the mounting brackets and readjust if necessary.
2. Check the gate for binding or hinge damage.
3. Adjust stall force if necessary.
4. Reprogram closed position limits.

Maintenance

Monthly, test the obstruction and entrapment protection systems.

Monthly, service the gate operator (make sure the power switch is OFF). Clean extended operator arm with a soft, dry clean cloth. After cleaning, apply a high quality silicon spray to a soft dry cloth and wipe the push/pull tube. DO NOT directly spray the tube!

On all gates weighing 250 lb. or more, routinely grease the ball bearing hinges at least 4 times a year; more frequently if the gates are near a coastal area.

Monthly, turn off the power switch and disconnect the Mighty Mule and move the gate to make sure the gate is moving freely without sticking or binding. Lubricate the hinges or repair the gate as required before reattaching the Mighty Mule.

Monthly, check the gate system for potentially entrapments from new landscaping or construction. Eliminate or guard as required.

Monthly, check that the warning signs are mounted on each side of the gate and clearly visible. Replace the signs if they are missing or damaged.

Replace batteries every 2-3 years and properly recycle old batteries.

Warranty Repair

If your Mighty Mule Gate Opener is not operating properly, please follow the steps below:

1. First use the procedures found in the Visual and Audible Diagnostic Indicators section ([page 24](#)).
2. Use the 24/7 Troubleshooting "Wizard" located at www.mightymule.com.
3. If you are unable to solve the problem, call the NSC Service Department at (800) 543-1236, or (850) 575-4144. Refer to the serial number (located on the back of opener arm) and date of purchase when calling for assistance.
4. If replacement of your gate opener is necessary, the Service Department will assign a **Return Goods Authorization (RGA) number** to you for all warranty repairs.
5. Securely pack the component(s) authorized for return to the factory. Write the RGA number issued to you on the outside of the package in **LARGE BOLD PRINT** and include a copy of the proof of purchase. Ship the package(s) freight prepaid to the address supplied during the RGA process:

NOTE: Products returned to NSC without a Return Goods Authorization (RGA) number in LARGE BOLD PRINT on the outside of the package WILL NOT be accepted. Also, items returned to NSC freight collect WILL NOT be accepted.

After the 12 month warranty expires, NSC, or one of its authorized service centers will perform necessary repairs for a nominal fee. Call NSC's Technical Service Department.



Mighty Mule Technical Service and Installation Assistance

8:00am–7:00pm • Monday–Friday (EST)

Toll Free Support: 800-543-1236 • Fax: 850-575-8912

24/7 Troubleshooting Wizard link found at: www.mightymule.com

Accessories



Please visit www.mightymule.com for photos and detailed descriptions of Mighty Mule Accessories, or call Mighty Mule sales 1-800-543-4283.

Solar Panel (FM123)

If your gate is more than 1000' from an AC power source, you can choose to maintain the battery charge with the Solar Panel Charging Kit. Installation in some regions of the world will require multiple solar panels for adequate charging power.

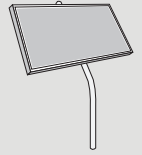

Pin Lock (FM133)

The Pin Lock substitutes for the clevis pin at the front end of the Mighty Mule gate openers. Helps prevent theft of the opener from the gate.

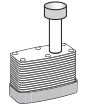

MMT103

The MMT103 Code Safe digital transmitter is a wireless radio control designed for use with Mighty Mule garage door openers and can also be programmed to your Mighty Mule gate openers. One remote for two or three devices.



MMK200 Keypad

The Mighty Mule Wireless Keypad is designed to control access to all Mighty Mule Garage Door Openers. This keypad features a LED back light that allows you to see numeric keys throughout dark or unfavorable weather conditions.



Mounting Post (FM100) - In Ground

This black powder coated pedestal is designed to provide convenient access to your keypad, wireless intercom, or other access control device from your vehicle. Surface Mount Flanges (F102) and Extensions (F103) for added height are available.



Mighty Mule Vehicle Sensor (FM138)

The Sensor is an electromagnetic sensor, which offers "hands free" operation of the Mighty Mule Gate Opener with a 12 ft. radius of detection of vehicles in motion. A wireless version of the Gate Opening Sensor is available. (FM130)

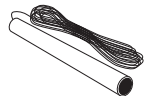

Automatic Gate Lock Pull-to-Open (FM143)

A MUST for added security. Solenoid driven, with a steel housing. Unlocks and locks automatically as gates open and close. Comes with a keyed manual release. Recommended for gates over 8 ft. long.



Accessories are Available From Your Retail Store (con't)

Low Voltage Wire (RB509)

The 16 gauge, multi-stranded, dual conductor Low Voltage Wire is for connecting the AC powered transformer, or the Solar Panel to the control board. Also used for the connection of accessories, such as locks, keypads, push buttons and other wired control devices. This specially designed wire is UV treated, PVC coated and ready for direct burial



Push to Open Bracket (FM148)

Required when Mighty Mule gate opener must push the gate open, such as on a sloping driveway or where space prevents gate(s) from opening inward (pulled open). Order two brackets for conversion of a dual swing gate installation.



Wireless Entry Intercom / Keypad (MM136)

Allows owner to screen guest at the gate before allowing access to the property. Keypad also allows owner to give up to 25 programmable entry codes to family, friends or approved delivery personnel. Codes can be permanent or temporary. Up to 500 feet reception. Additional base stations available (MM136B).



Replacement Transformer (RB503)

16VDC power supply for maintaining the battery with the Mighty Mule gate operator.

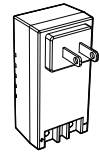

Garage Door Receiver (RB709U-NB)

The Garage Door Receiver allows you to use the same 2 button Mighty Mule entry transmitter to operate your gate operator and your garage door operator. Compatible with most garage door operators.

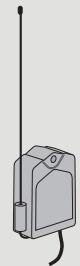

Wireless Driveway Alarm (FM231)

This device alerts you of vehicles entering and exiting your property. When a vehicle passes the sensor, the receiver emits an audible tone and lets you know someone's there. Functional range of up to 400 ft. Easy-to-install.



Wireless Driveway Vehicle Sensor (FM130)

Automatically activates gate operator "Hands-Free" when a vehicle exits the property. 100 ft. range between transmitter and receiver. Easy installation.



If you have a question about any special order item, call 1-800-543-4283

The contents of all material available on this installation manual are copyrighted by Nortek Security & Control, LLC ("NSC"), unless otherwise indicated. All rights are reserved by NSC, and content may not be reproduced, downloaded, disseminated, published, or transferred in any form or by any means, except with the prior, written permission of NSC. Any reprinting of NSC publications is by permission only. Copyright infringement is a violation of federal law.

Mighty Mule®, E-Z Gate®, NSC®, "Dual Sense Technology" are registered trademarks of Nortek Security & Control, LLC. America's DIY Automatic Gate Openers is a trademark of Nortek Security & Control, LLC and are the exclusive property of Nortek Security & Control, LLC ("NSC").

All rights are reserved by NSC, and these marks may not be used, in any for without the prior, written permission of NSC.

Gate Operator Installation Checklist

- 1. The gate has been checked to make sure it is level and moves freely in both directions.
- 2. Potential pinch areas have been guarded so as to be inaccessible OR have sensing edges and/or photo beam obstruction detection devices installed.
- 3. The installer has installed one or more contact or non-contact obstruction sensing devices, if required for this installation.
- 4. If pedestrian traffic is expected, a separate pedestrian gate has been installed, a minimum of seven feet from the gate system. All pedestrian traffic must use the pedestrian gate.
- 5. Warning signs have been installed on each side of the gate in highly visible locations. These signs must remain at all times.
- 6. There are no controls installed on the gate operator, or within 10 feet of the gate.
- 7. The Dual Sense Technology™ feature has been properly adjusted to the minimum operational setting for your application.
- 8. Reviewed and understand all of the operational functions, obstruction sensing devices, warning beeper and reset, etc.
- 9. Review and understand the proper use of the operator's manual disconnect feature. The manual disconnect must never be used while the gate is in motion. The power switch must be turned off before using the manual disconnect and disengaging the operator.
- 10. Reviewed all safety instructions, and keep the safety instructions and owner's information sheets for reference.
- 11. Review and understand the maintenance schedule for both the gate and the gate operator.

VOLTAGE RATINGS

14 Vac Transformer _____ 13.0 to 16.0 Vac

10 W Solar panel _____ 18.0 to 22.0 Vdc 600 mA

Measure voltage at panel and control box.

12 V Battery _____ 12.5 to 13.5 Vdc

Charging circuit _____ 13.8 to 14.8 Vdc

Measure voltage at battery terminals with battery connected



NORTEK™
SECURITY & CONTROL



800-543-4283 • Fax (850) 575-8912

Website www.mightymule.com

24/7 Troubleshooting Wizard:

Link can be found at: www.mightymule.com

The contents of all material available on this installation manual are copyrighted by Nortek Security & Control, LLC ("NSC"), unless otherwise indicated. All rights are reserved by NSC, and content may not be reproduced, downloaded, disseminated, published, or transferred in any form or by any means, except with the prior, written permission of NSC. Any reprinting of NSC publications is by permission only. Copyright infringement is a violation of federal law.

Mighty Mule®, E-Z Gate®, NSC®, "Dual Sense Technology" are registered trademarks of Nortek Security & Control, LLC. America's DIY Automatic Gate Openers is a trademark of Nortek Security & Control, LLC and are the exclusive property of Nortek Security & Control, LLC ("NSC").

All rights are reserved by NSC, and these marks may not be used, in any form without the prior, written permission of NSC.