

Sliding Gate Opener User Manual GTR061

Please Note: This motor runs on AC Power as standard but can also be operated by DC Battery Backup or Solar Power.

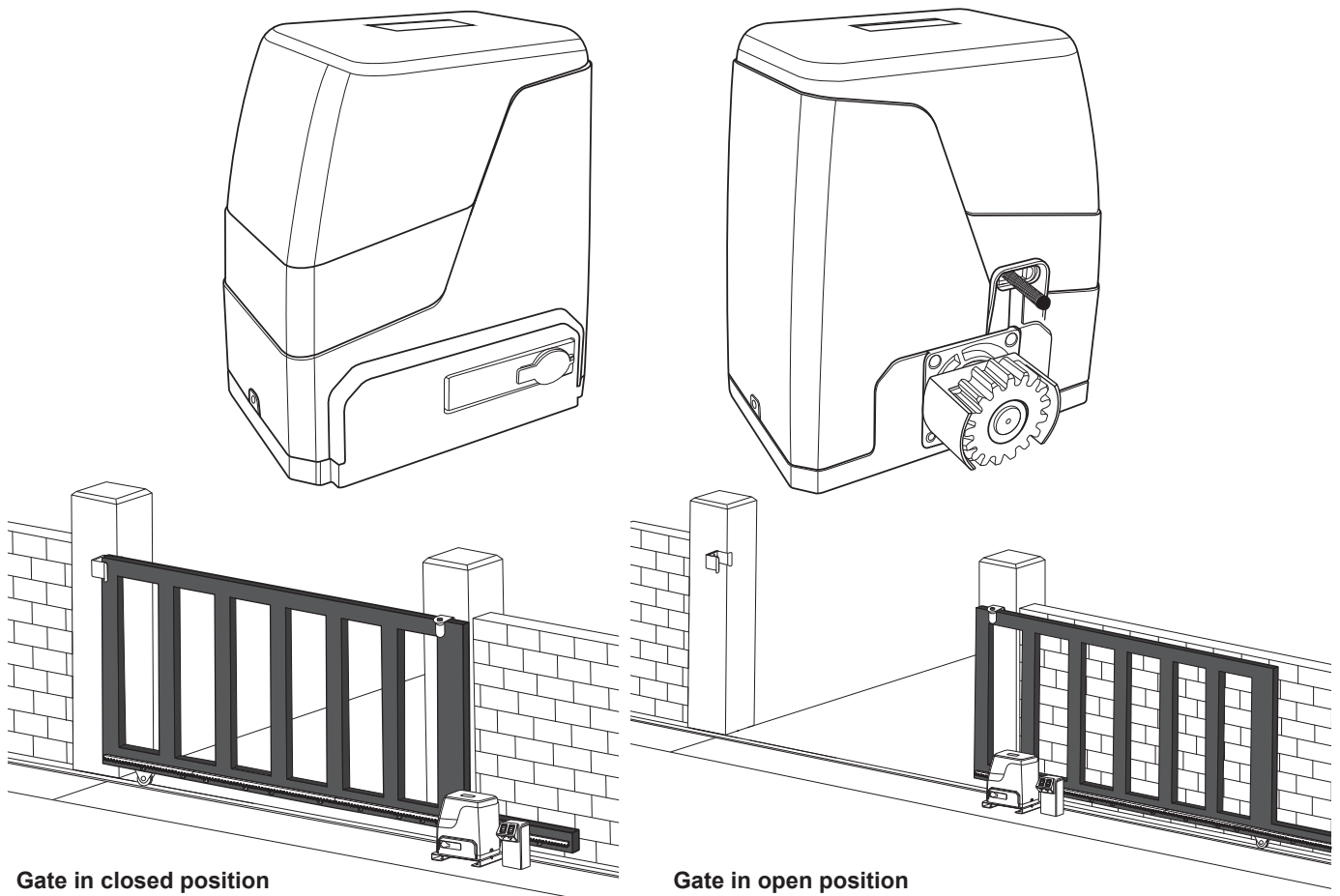

Gate in closed position

Gate in open position

Viewed from inside the property

TECHNICAL SUPPORT

Instructions must be read before beginning installation. Please follow these instructions carefully, incorrect installation could affect gate operation. If you require more information, please contact your local Richmond Wheel & Castor Co branch.

For installation or troubleshooting assistance visit richmondau.com/gate-motor-support/

AU: 03 9070 5713 NZ: 0800 61 71 81 International: +613 9551 2233

Optional Accessories Available:

Additional Remotes (GTR179): Spare/Additional remotes for the automatic gate kit, these will need to be paired to the motor.

Remote External Receiver (GTR197): Allows more remotes to be paired to the motor. Pair up to 250 remotes with this accessory.

Wireless Keypad (GTR180): Allows secure access through the gate used with a user set code.

Wireless Push Button (GTR201): Allows access through the gate at the push of a button.

Hard Wire Push Button (GTR202): Allows access through the gate at the push of a button.

Reflective Photocells (GTR208): Increase safety during opening/closing by preventing gates from closing on vehicles/pedestrians.

Warning Light (GTR198): Alerts people near the gate and users that the gate is in operation.

Solar and Battery Backup Packs Available: Solar panels and more available to get this gate kit running on solar power. Please contact your nearest authorised dealer for compatible solar panels in your state/region.

Please refer to the relevant manual for each accessory for instructions on wiring them to the GTR061 gate motor.

Contents:

Gate Opening Default Setting Information	4
General Safety	5
Parts List	6
Technical Specifications	7
Motor Installation	
Before you start	8
Tools Required / Example Sliding Gate Setup	9
Step 1 – Gate Preparation	10
Step 2 – Motor Pad Footing	11
Step 3 - Motor Position Installation	11
Step 4 – Drilling Holes for Anchor Bolts	12
Step 5 – Fitting the Mounting Plate & Motor	12
Step 6 – Gear Rack & Motor Alignment	13
Step 7 – Limit Travel Stops	15
Step 8 – Powering the Motor	17
Step 9 – Testing the Limit Travel Stops	18
Programming and Wiring	
Control Board Diagrams	19
Dip Switch Adjustment	22
Further Settings and Programming	23
Battery/Solar Connection	26
Connecting Battery Backup (sold separately)	26
Connecting Solar Power (sold separately)	27
Troubleshooting	28
Clearing and Pairing Remotes	29
Additional Drawings and Diagrams	30
Maintenance	30

For accessories: please refer to the relevant accessory manuals for instructions on wiring them to the GTR061 motor.

Gate Opening Default Setting Information:

The gate motor will open the gate to the right-hand side as its default setting (refer to fig 1).

It is recommended that you allow a minimum 500mm bottom rail extension from your inside gate post opening. This will enable you to have enough room to secure your gear rack and placement for the motor.

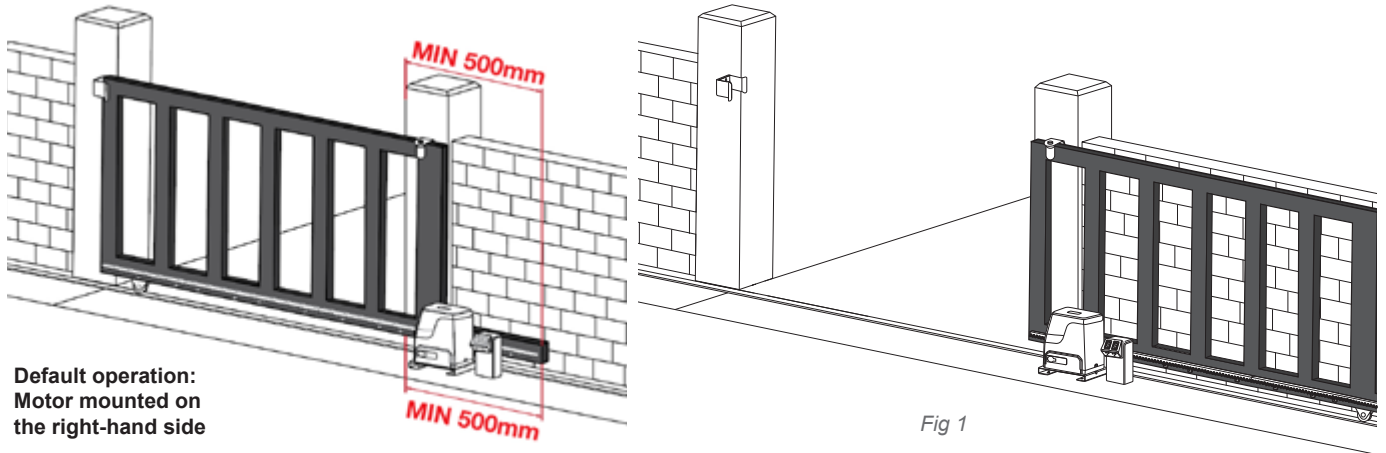

Default operation:
Motor mounted on the right-hand side

Fig 1

Before Installing: Test the motor by plugging it into a power source and pressing the remote. You will see the motor cog turn. When it stops (after approx 1 minute), press the remote again to see it turn in the opposite direction. This will give you an understanding of the way in which the motor will move the gate.



Press the first/top button on the remote.

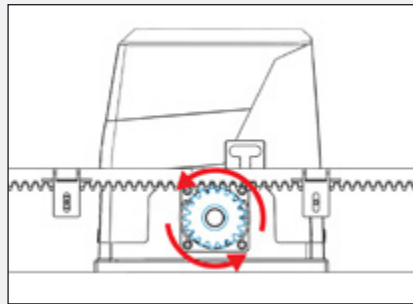

The motor cog will turn counter-clockwise, moving the gate frame.

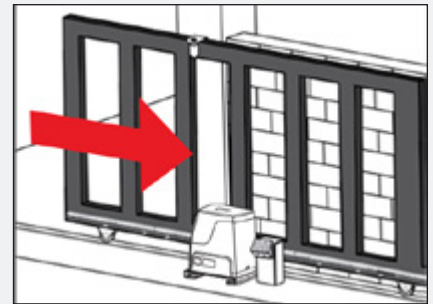

The gate will then move in the set direction. Default: right-hand open.

Note: Ensure that the motor is unplugged before proceeding with installation. Please keep fingers away from the motor cog whilst it is turning.

If your gate needs to open from the other direction (to the left, refer to fig 2) your motor needs to be mounted on the left-hand side as shown below, you will need to switch DIP SWITCH 5 from OFF to ON (refer to page 22).

It is recommended that you allow a minimum 500mm bottom rail extension from your inside gate post opening. This will enable you to have enough room to secure your gear rack and placement for the motor.

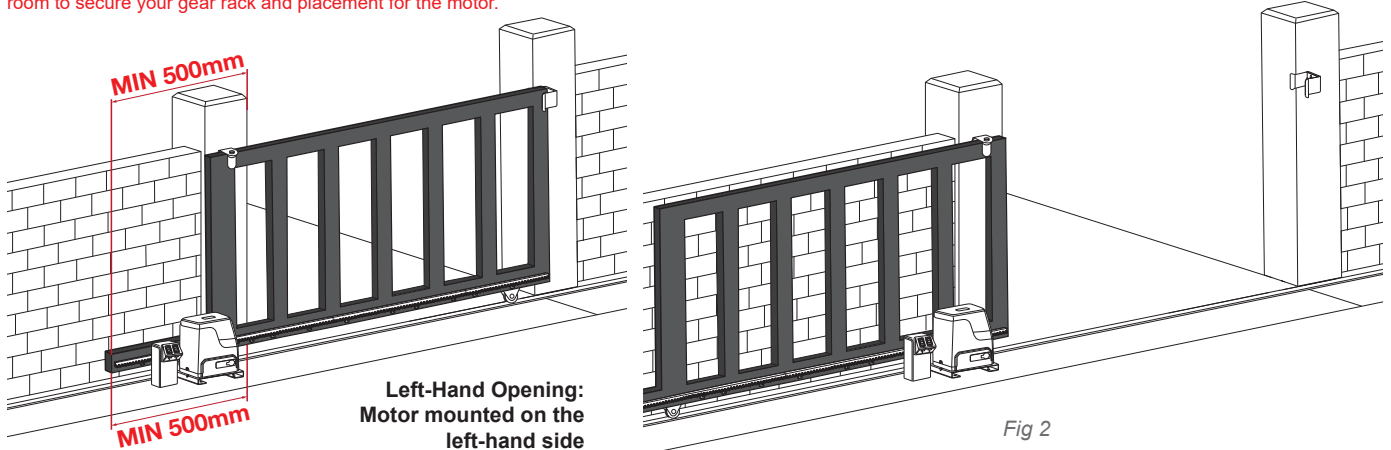

Left-Hand Opening:
Motor mounted on the left-hand side

Fig 2

Any works done to the motor must be completed whilst the power is off and the motor is unplugged

Thank you for choosing this sliding gate opener. Please read the manual carefully before assembling and using the opener. Do not leave out the manual if you send this product to a third party. This product complies with the recognised technical standards and safety regulations. Our company has the right to change this manual without prior notice.











General Safety:

Warning: Incorrect or improper use of this product can cause damage to persons, animals or properties.

- Warning: Incorrect or improper use of this product can cause damage to persons, animals or properties.
- Please ensure that the input voltage used matches with the supply voltage of gate opener (AC240V 50Hz).
- All modifications to wiring or electrics, and any adjustment or maintenance to 240VAC MUST be done by a qualified electrician.
- To avoid damaging gas, power or other underground utility lines, contact the relevant authority BEFORE digging.
- All potential hazards and exposed pinch points of the gate must be eliminated or guarded prior to installation of this gate motor.
- Never mount any device that operates the gate motor where the user can reach over, under, around or through the gate to operate the controls. These must be placed at least 1.8m from any moving part of the moving gate.
- Ensure power plug is disconnected from the power socket during installation or maintenance.
- Keep remote control and other control devices out of children's reach, in order to avoid unintentional activation.
- Never allow anyone to hang onto the gate while moving.
- Please ensure a warning sign provided is fitted to the structure.
- To ensure safety, before installing the main motor, mount a Gate End Stop (GTR017) and a Gate Stopper (GTR017 or GTR018) at each end of the rail to prevent the gate travelling off the track.
- If required, install infrared photocells (GTR096, sold separately) to detect obstructions and prevent injury or damage.
- • Instruct all users about the control systems provided and the manual opening operation in case of emergency.
- • Ensure that the power cable is connected to a RCD protected weatherproof power outlet installed by a qualified electrician.
- Do not install the product in an explosive atmosphere or where there is any danger of flooding.
- This product was exclusively designed and manufactured for the use specified in the present documentation. Any other use not specified in this documentation could damage the product and be dangerous.
- Only use original parts for any maintenance or repair operation. Richmond Wheel & Castor Co declines all responsibility with respect to the automation safety and correct operation when other supplier's components are used.
- Do not modify the automation components, unless explicitly authorised by Richmond Wheel & Castor Co.
- The user must avoid any attempt to carry out any works or repairs on the motor, and should always request the assistance of qualified personnel.
- This motor is suitable for use on one sliding gate only.
- Anything which is not expressly provided for in these instructions is not allowed and will void warranty.
- Dispose of all packing materials (plastic, cardboard, polystyrene etc.) according to current guidelines. Keep plastic bags and polystyrene out of children's reach.

Please save these instructions for future use.

Parts List:

No.	Picture	Name	Quantity
1		Main motor	1
2		Motor Mounting Plate	1
3		Manual release keys (These keys are needed during power outage, keep on hand)	2
4		Remote controls (factory paired to motor)	2
5		Gate Warning Signage (must be fitted to gate)	1
6		In the accessories box you will find the items below:	1
6a		Limit travel stops (left hand & right hand)	2
6b		Limit switch mounting plate screws M6X18	4
6c		M12 x 100mm masonry anchor bolts (Drill bit size: M12 masonry)	4
6d		Motor mounting set screws M10 x 50mm, spring & flat washers	4

Technical Specifications:

Model	GTR061
Power supply	240V/50Hz
Motor power	170W
Gate moving speed	16-18m/min
Maximum weight of gate	800 Kg
Remote control distance	Up to 30m
Remote control mode	Single button mode
Limit switch	Spring limit switch
Noise	Up to 58dB
Working duty	S2, 20min (20 minutes continuous operation)
IP Rating	IP54
Maximum Remote Controls to be paired	25
Frequency	433.92 MHz
Working temperature	-20°C ~ +70°C

1. Open/Close

Press the button for standard gate opening and closing operation.



4. Pedestrian Mode

Press the button while the gate is closed, the gate will open 1m wide to allow pedestrian access. Press the remote again to close.

Fig 03

Motor Installation:

Before you start

- The GTR061 Sliding Gate Motor is suitable for powering the opening and closing motion of gates up to 800kg in weight, and up to a length of 8m on level, flat ground.
- Gate motion is achieved by the rotating cog of the gate motor driving the gear rack fitted to the moving gate (sold separately).
- The gate motor requires you to press the remote control once to open, and once again to close. This is a safety feature to ensure safe operation.
- The gate motor itself must be fitted within private property, never externally to a property's boundary.
- This premium motor has a range of optional accessories which can be added, such as solar power, battery backup, infrared photocells, keypads, push buttons, and warning light.

Power Supply: The GTR061 requires 1 x 10Amp AC240V 50Hz power supply (RCD Protected Weatherproof PowerPoint). The GTR061 comes complete with a power lead and plug that is 1m long. If you do not have a suitable RCD protected weatherproof power point within 1m of the gate motor you will need to consult a licenced electrician.

Any works done to the motor must be completed whilst the power is off and the motor is unplugged. The gate motor will open the gate to the right-hand side as its default setting (refer to fig 1).

Any modifications/alterations/works to the 240V AC power components must only be completed by a licensed electrician for your state/country.

Please Note:

- Your weatherproof power outlet should be no more than 1m from the electric gate motor.
- If your weatherproof power outlet is more than 1m from the gate motor, you will require a licensed electrician to fit a new power cable.
- Any excess cable length should be cable tied and secured out of the way of moving objects.

For Installing Your Gate Motor, You Will Need:

- Power drill
- Tape measure
- Level
- 12mm Masonry Drill Bit (for the 4 motor masonry anchor bolts)
- Socket and Spanner Set
- Phillips Head Screwdriver

Example Sliding Gate Setup:

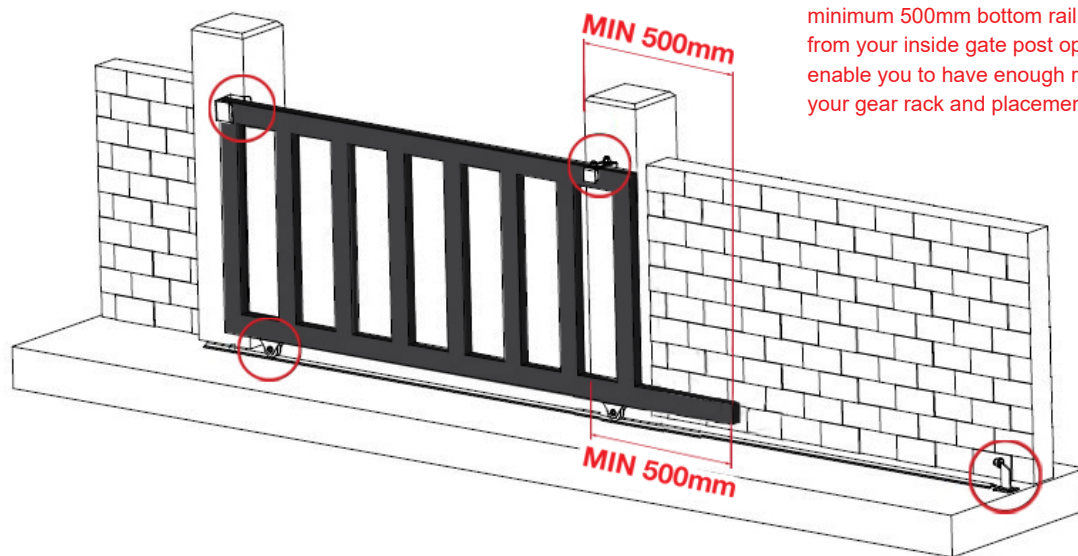

It is recommended that you allow a minimum 500mm bottom rail extension from your inside gate post opening. This will enable you to have enough room to secure your gear rack and placement for the motor.

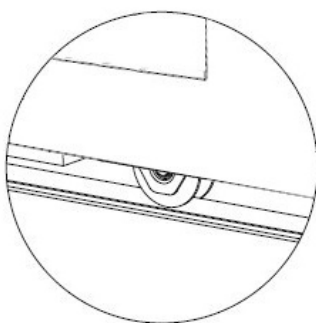

Gate Track and Track Wheels

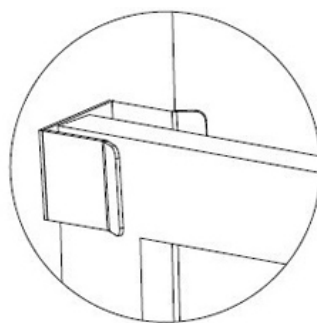

Gate End Catch

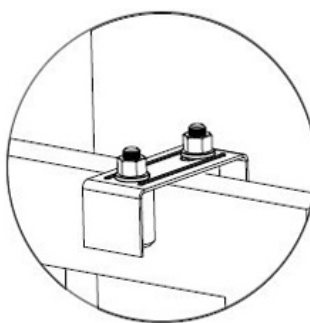

Gate Guide Rollers



Gate Stopper

If you require any gate hardware, contact Richmond Wheel & Castor Co or an authorised reseller.

Please ensure that the motor power cable is not plugged in at any stage before Step 8

Step 1 - Gate Preparation Before Adding Your Sliding Gate Motor:

- Ensure that the sliding gate is correctly installed.
- The gate is horizontal and level and the gate can glide back and forth smoothly when moved by hand before installing the Automatic Gate Opener.
- Wheels and guide rollers should rotate easily and be free from dirt/grime.
- Track should be flat, level and firmly affixed.
- Any misalignment in the gate will affect performance of the automatic gate opener.

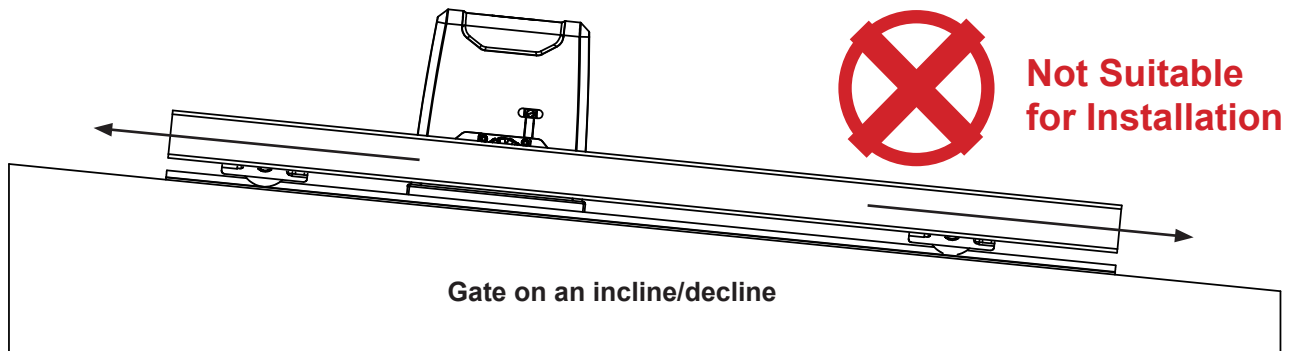
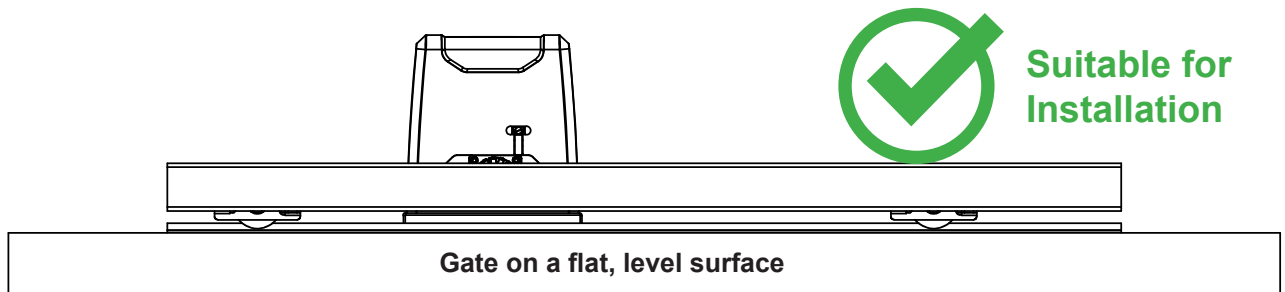

For installation on sloping surfaces contact Richmond to discuss a suitable motor option

Step 2 - Motor Pad Footing (Minimum Requirement):

- The motor pad concrete footing requires an area of no less than 450mm long x 300mm wide and a minimum depth of 200mm (Standard requirement).
- Ensure surface is level and parallel to the driveway
- **Concrete pad should be min 20-25MPA** (Rapid Set Concrete not recommended) allow to cure for 7-10 days before drilling and securing the mounting plate into position.

Mounting Plate Dimensions:

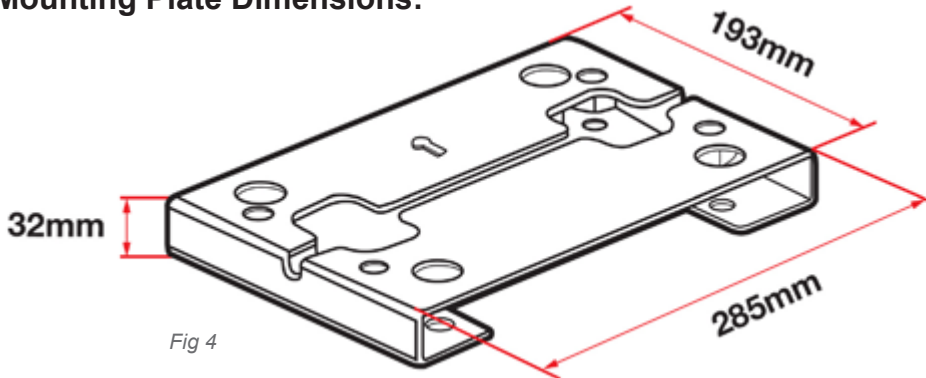

Step 3 - Motor Position Installation:

- Insert the key and open the manual release bar to put the motor into manual mode, and check that the motor cog rotates freely by hand (As per Fig 17).
- Place the motor and motor mounting plate on the concrete pad.
- Make sure the distance between the gate motor cog and gear rack position are aligned.
- Mark all four corners of the mounting plate on the concrete pad using a pencil, chalk or similar, to ensure the mounting plate is in the correct position before drilling.
- Remove motor from the mounting plate.

When mounting and positioning the motor ensure that the power cable is unplugged. The motor cover will need to be removed to mount the motor to the mounting plate.

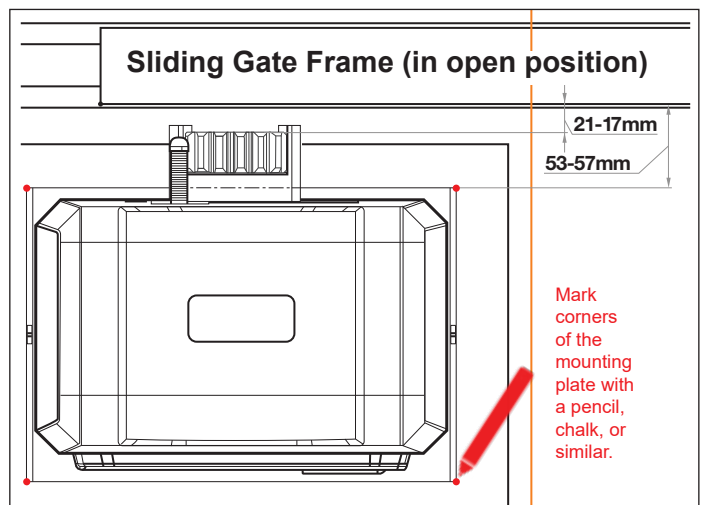
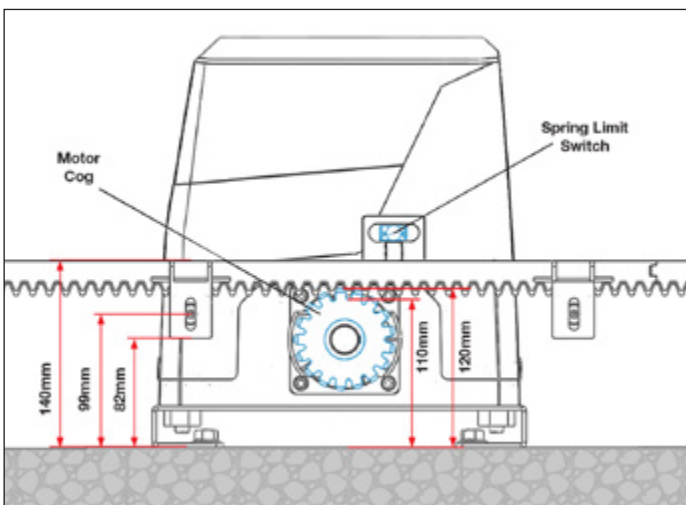

Once the gate has been placed onto the gate motor the gate must move back and forth freely at all times when in manual release mode

Step 4 - Drilling Holes for Anchor Bolts:

- Mark the (4) positions for your anchor bolts ready for drilling (refer to Fig 7).
- Remove Mounting plate.
- Using a M12 masonry drill bit, drill holes to a minimum depth of 120mm (Fig 8).

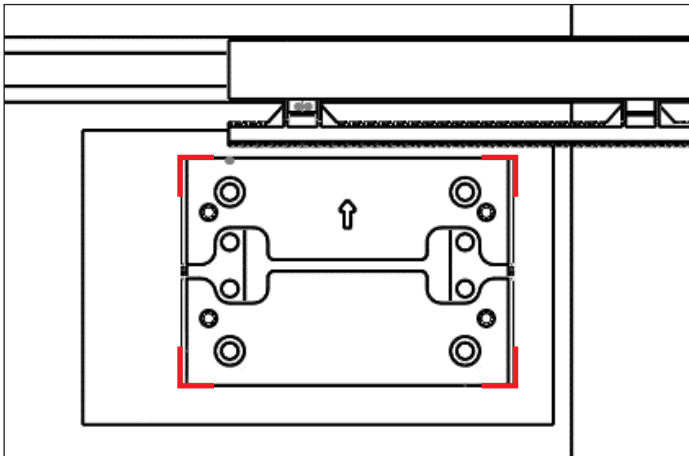

Fig 7

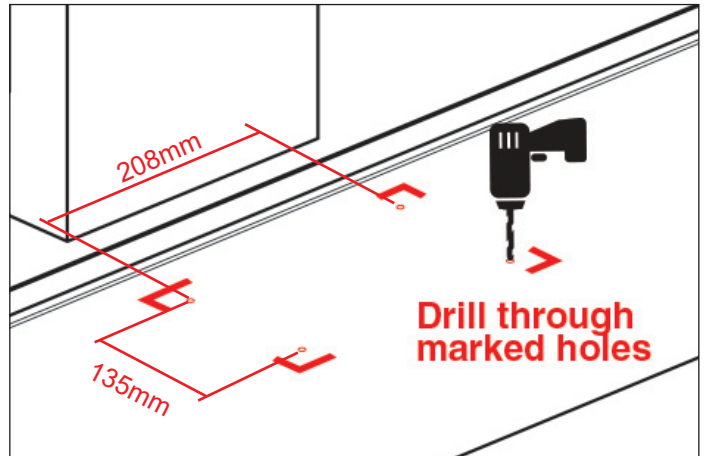

Fig 8

Step 5 - Fitting Mounting Plate & Motor:

- Fit motor mounting plate back into place and fit and tighten anchor bolts (as per figures 9 and 10).
- Fit motor back on mounting plate, ensuring the power cord is positioned into the end slot of the mounting plate in the direction of the power point, making sure there are no pinch points (as per fig 11).
- Slide rubber grommet along the power lead and into the end slot of the mounting plate (as per figures 12 & 13).
- Bolt motor to the mounting plate using the M10 x 50mm bolts with spring and flat washers provided and tighten as required (as per figure 14).

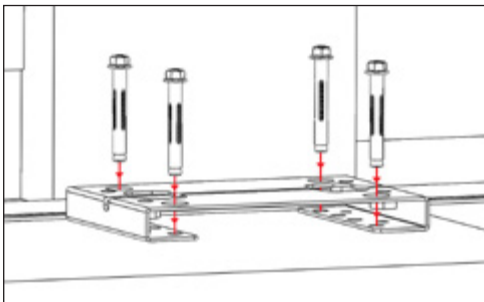

Fig 9

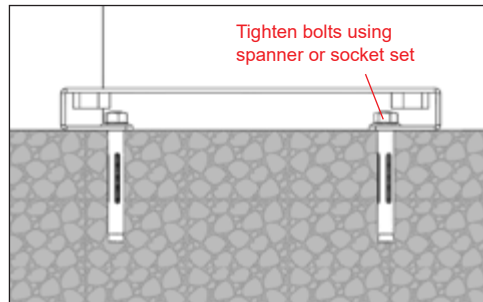

Fig 10

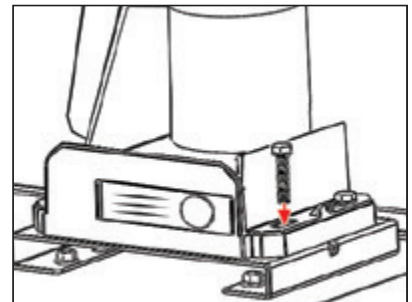

Fig 11



Fig 12



Fig 13

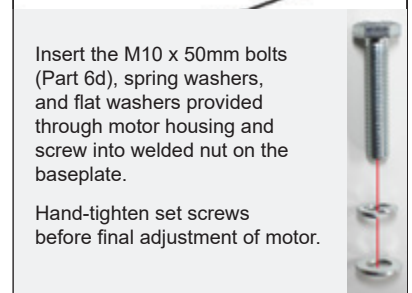

Fig 14

Insert the M10 x 50mm bolts (Part 6d), spring washers, and flat washers provided through motor housing and screw into welded nut on the baseplate.

Hand-tighten set screws before final adjustment of motor.

Once the gate has been placed onto the gate motor the gate must move back and forth freely at all times when in manual release mode

Step 6 - Gear Rack & Motor Alignment:

- Insert the key and open the manual release bar to put the motor into manual mode, and check that the motor cog rotates freely by hand (as per fig 17).
- Ensure that the gate drive cog has a minimum clearance of 1-2mm along the entire length of gear rack fitted to the gate (as per Fig 15)
- Ensure cog and rack are correctly aligned. Under no circumstances should the gate motor drive cog carry any weight of the gate. It is the task of the gate castors or wheels to carry the weight of the gate. (As per Fig 16)
- **If the gate doesn't slide freely by hand, adjust gear racks height accordingly until the full length of gate slides freely by hand**

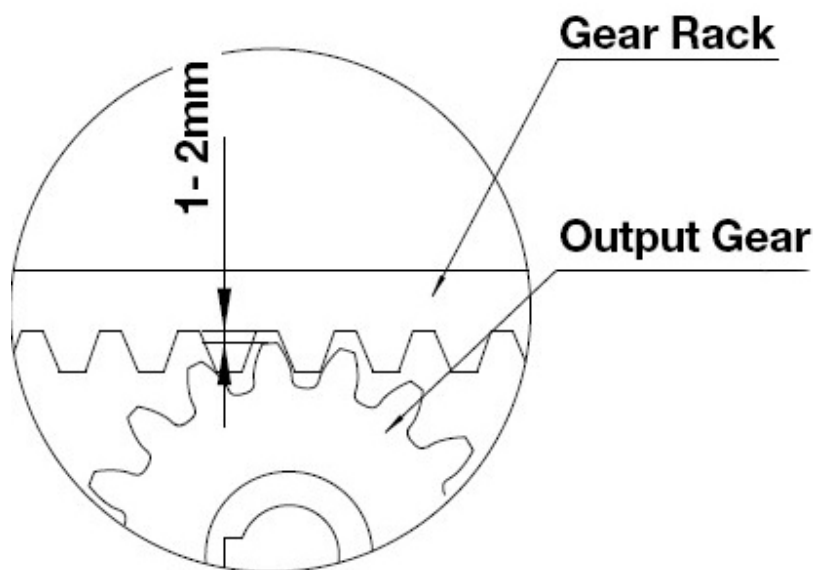
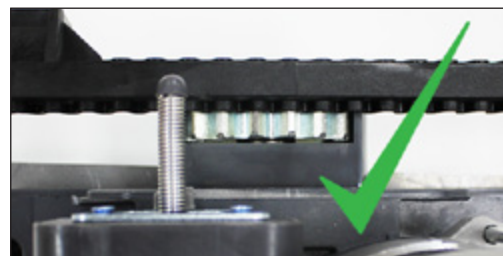
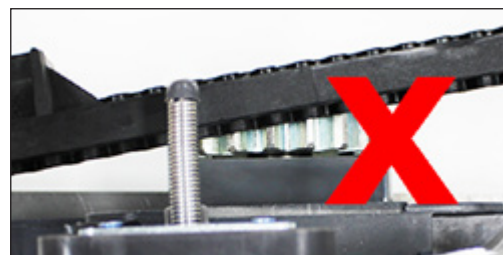

Fig 15



Gear rack correctly aligned at 90° to the motor cog



Gear rack misaligned. Do not attempt to use if misaligned.

Fig 16

At this stage of final assembly, the cover is removed (not shown) and the power cable is still unplugged.



To put the gate motor into manual mode, insert the key and open the manual release bar as shown

In manual mode, the gear can turn freely and the gate can be operated by hand

Fig 17

At this stage of final assembly, the cover is removed (not shown) and the power cable is still unplugged.

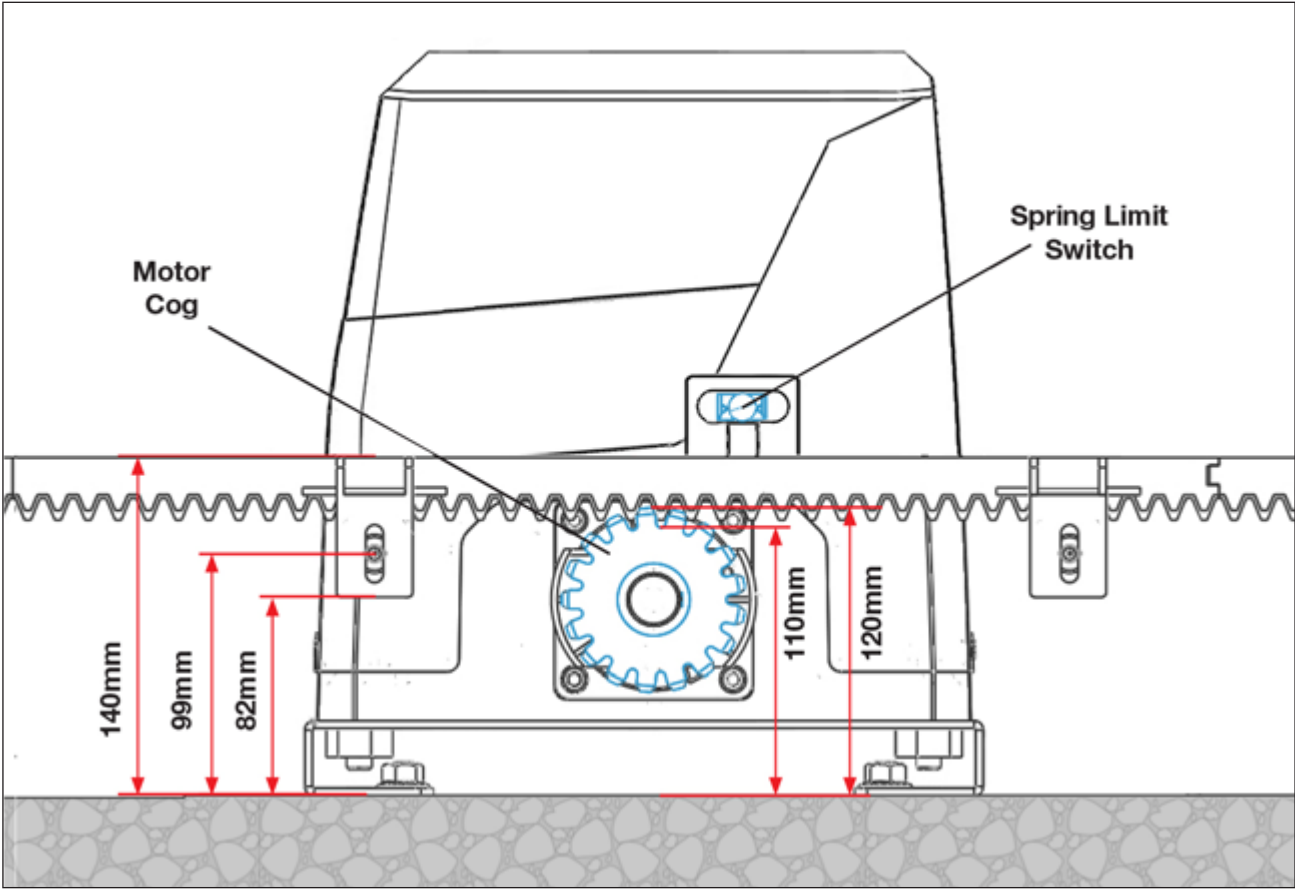

Fig 18

Step 7 - Limit Travel Stops:

Included in your gate motor kit are two limit travel stops (Part 7a) which must be fitted to the gear racks on your gate to ensure safe operation.

The limit travel stops are designed to set the desired opening and closing position of your gate. These limit travel stops are designed to come into contact with the spring limit switch.

Please note: gates can open and close in different positions due to different weights of gates, terrains, slopes (uphill or downhill). The distance the gate will travel after contacting the spring limit switch may vary.

Instructions on setting the limit travel stops can be found on the next page

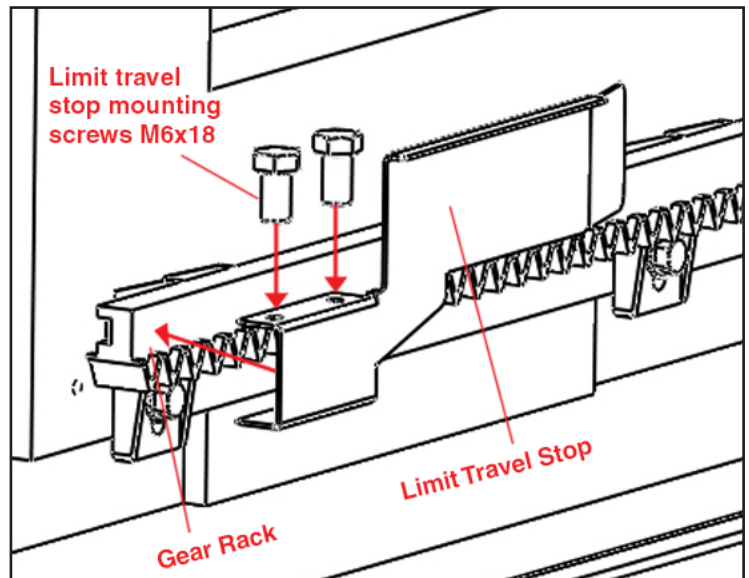

Fig 19



The installation of spring limit switch block is shown in Figure 20

Fig 20

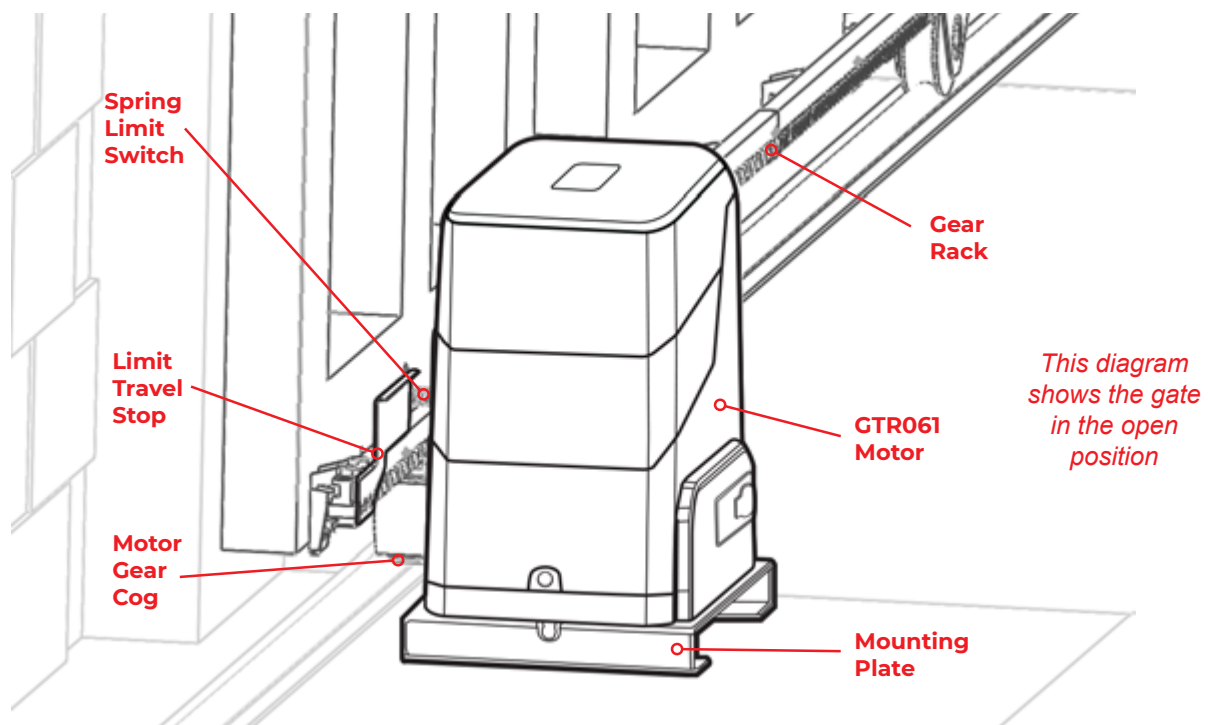

Fig 21

Setting the Limit Travel Stops:

Closed Position:

- Position gate 150-200mm back from the gate end catch closed position. This will help in making sure you do not slam the gate into the end stop/catch when setting the closed position under power.
- Fit limit travel stop onto the top of gear rack at the point where it meets the spring limit switch on the motor.
- Tighten locking screws.

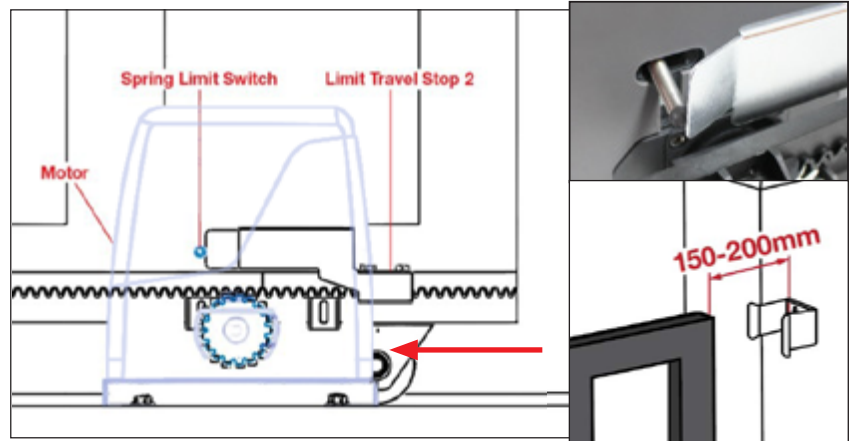

Fig 22

Open Position:

- Position gate 150-200mm back from the gate stopper open position. This will help in making sure you do not slam the gate into the end stop/catch when setting the open position under power.
- Fit limit travel stop onto the top of gear rack at the point where it meets the spring limit switch on the motor.
- Tighten locking screws.

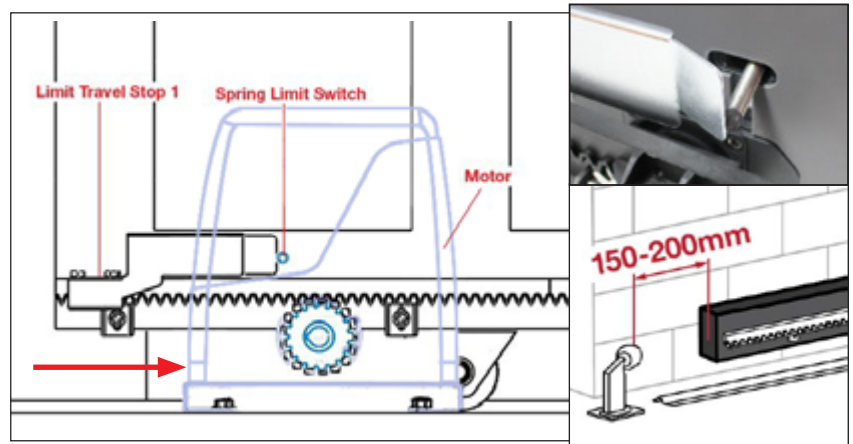

Fig 23

Test the spring limit travel stops by moving the gate manually until you hear a click, making sure contact is made with the spring limit switch on the motor.

To Reset: When setting new limit travel stop positions please ensure that you turn the power off and then on again. Turning the power off will reset the limit travel stop memory, allowing for new limit travel stop positions to be recognised by the motor.

Once satisfied the gate is opening and closing to the test limit switch position. Set the limit travel stop positions in place (see Step 8 and Step 9 for instructions on powering the motor and testing the limit switch positions).

Step 8 - Powering the Motor:

- Ensure that the outer cover has been fitted and fastened back onto the motor housing.
- Before powering up the motor make sure the gate can travel by hand in manual mode (key unlocked).
- Slide the gate to between the middle of the posts, approximately (see below diagrams).
- Lock the key (key locked) in readiness for automatic mode.
- Plug the power cord from the low voltage power supply into the power outlet.
- Remote controls (Part 4) included in this kit are factory paired ready for use.

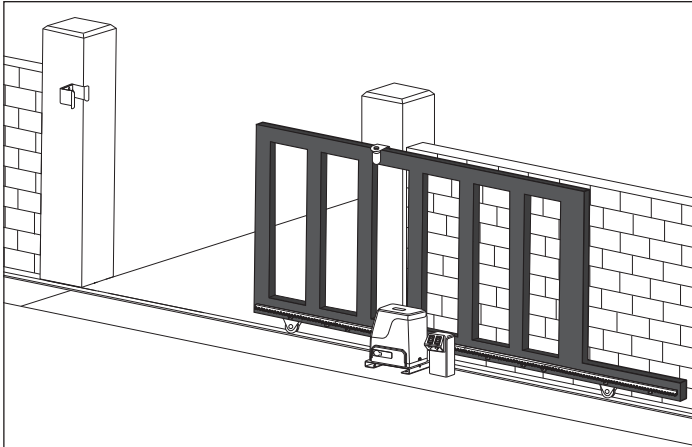

Please Note:

- The default setting is opening to the right. 
- Press the remote control and the gate will open until the spring limit travel stop hits the spring limit switch. Press the remote control again and the gate will close.
- Soft start/soft stop function - The GTR061 is set by default to provide the soft start/soft stop function. We recommend this default position is always maintained.

Your motor is now set up for basic remote control operation. To set further functions and settings, see pages 19-27

For accessories: please refer to the relevant accessory manuals for instructions on wiring them to the GTR061 motor.

Step 9 - Testing the Limit Travel Stops:

Testing the closed position

- Ensure motor is plugged in as per step 8 and the gate is in the open position.
- Press remote (remotes included in kit are factory paired to the motor). The gate will begin to close.
- The limit travel stop will hit the spring limit switch and the gate will stop.
- When the gate stops, measure the distance remaining between the gate and the desired closed position.
- You have now determined the closed position of the gate when the travel limit stop hits the spring limit switch.
- **Adjust the limit travel stop from the measurement you have taken to get your final gate closed position. The ideal closed final position for the gate frame is 10-15mm from closed gate end catch (GTR019).**

Testing the open position

- Press remote. The gate will begin to open.
- The limit travel stop will hit the spring limit switch and the gate will stop.
- When the gate stops, measure the distance remaining between the gate and the desired open position.
- You have now determined the open position of the gate when the travel limit stop hits the spring limit switch.
- **Adjust the limit travel stops from the measurement you have taken to get your final gate open position. The ideal open final position for the gate frame is 10-15mm from the gate stopper (GTR017).**

Warning:

Please allow space to ensure the gate does not impact against the gate catch or the end stop. See fig 24

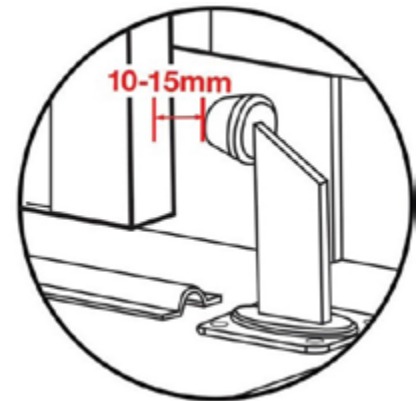
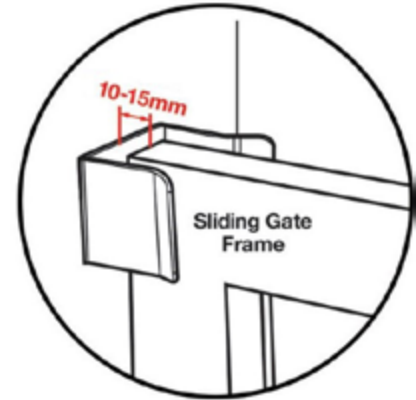

Fig 24

To Reset: When setting new limit travel stop positions please ensure that you turn the power off and then on again. Turning the power off will reset the limit travel stop memory, allowing for new limit travel stop positions to be recognised by the motor.

Programming and Wiring: Control Board Wiring Diagram 01

Ensure power is off before any modifications are made

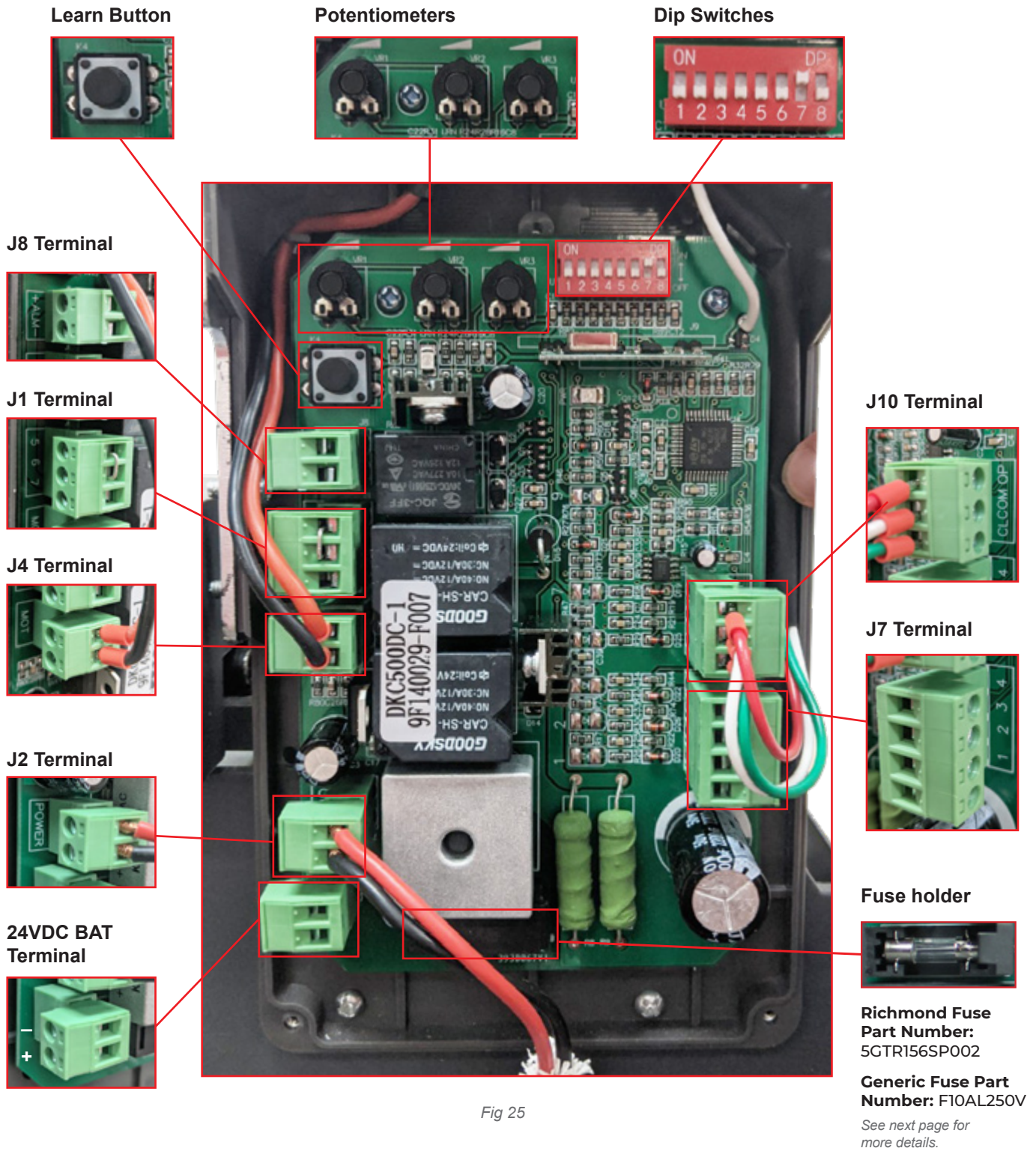

Fig 25

Richmond Fuse
Part Number: 5GTR156SP002
Generic Fuse Part Number: F10AL250V
 See next page for more details.

Please refer to page 24 and 25 for added description of the terminals

Programming and Wiring: Control Board Wiring Diagram 02

Ensure power is off before any modifications are made

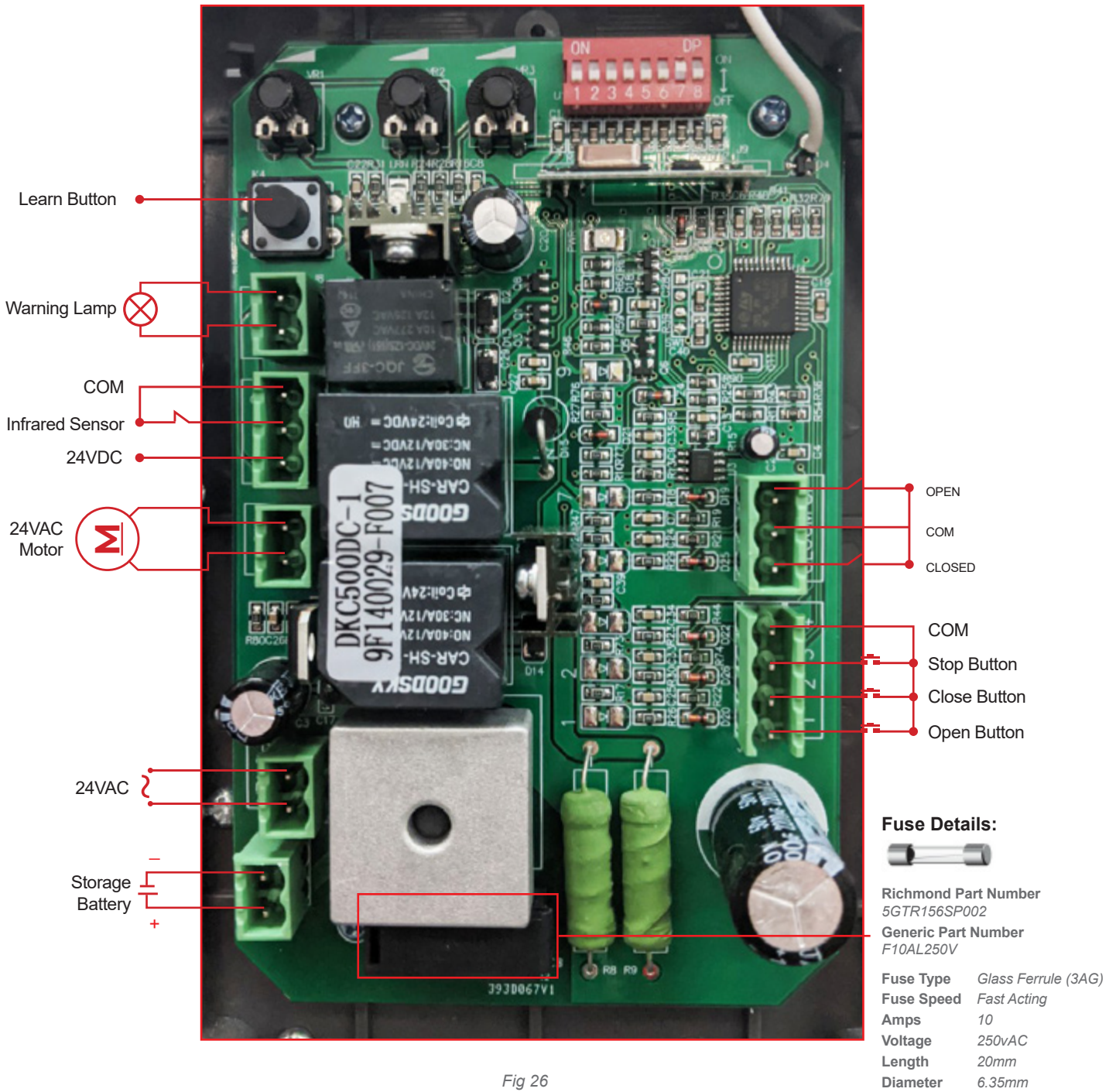

Fig 26

Please refer to page 24 and 25 for added description of the terminals

Transformer Power Input Connection:

WARNING: Do not touch 240V AC. All works to mains power must be conducted by a licensed electrician

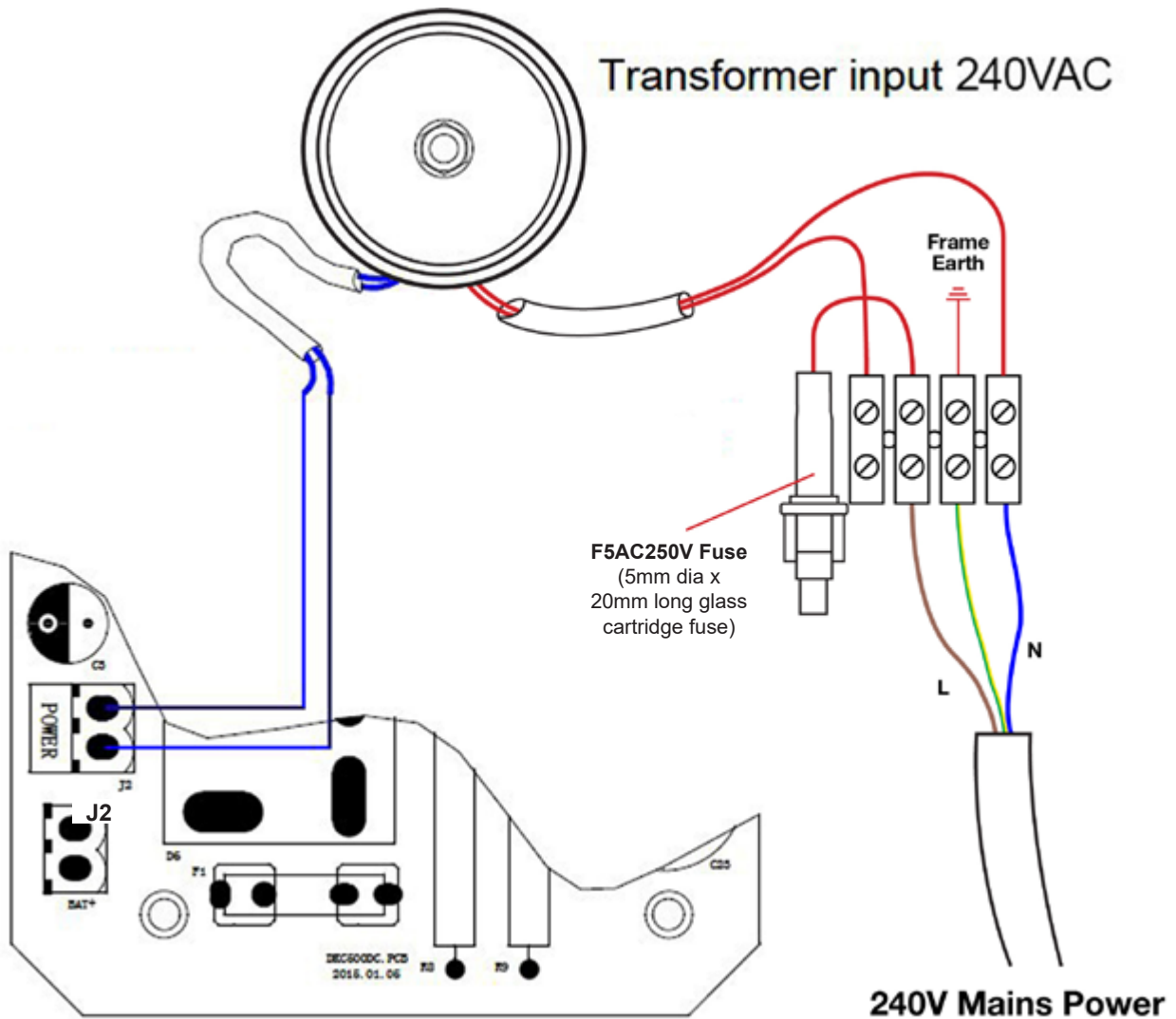
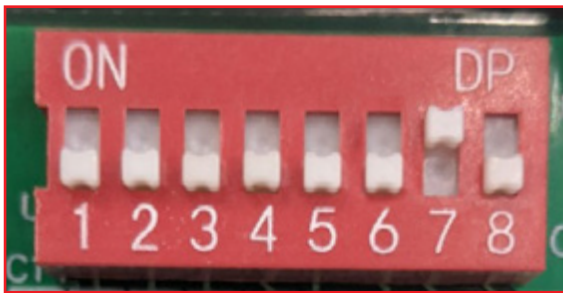









Fig 27

Dip Switch Adjustment:



Number	Description
	<p>Automatic Close Function 1 ON 2 OFF: automatic close delay time is 3s. 1 OFF 2 ON: automatic close delay time is 10s. 1 ON 2 ON: automatic close delay time is 30s. 1 OFF 2 OFF: no automatic close function.</p>
	<p>Default position is 1 OFF 2 OFF</p>
	<p>Remote Control Mode leave in OFF position unless an additional module is used. Default position is OFF</p>
	<p>External Button Mode Leave in OFF position unless an additional module is used. Default position is OFF 4 OFF: Hard wire keypad</p>
	<p>Left/Right Open Setting OFF – Right hand open ON – Left hand open Gate close direction will be changed after motor is restarted Default position is OFF (right hand)</p>
	<p>Spring Limit Switch Leave in the OFF position, OFF - Normal close ON - Normal open Default position is OFF (do not change)</p>
	<p>Stall Force ON - Enabled OFF - Disabled Default position is ON (do not change)</p>
	<p>Infrared Detection Delay When Closing ON – Infrared detection delay is set to 1 second OFF – Infrared detection delay is disabled Default position is OFF</p>

Further Settings and Programming:



VR1: Motor Running Time Adjustment

Rotate clockwise to increase, counter-clockwise to decrease. Motor running time can be set to 10 seconds minimum, and 90 seconds maximum.

The default setting is at maximum.

VR2: Unused

VR3: Stall Force Adjustment

Rotate clockwise to increase, counter-clockwise to decrease.

The default setting is at midway.

When stall force is enabled (DIP switch 7 is at the ON position), the motor will detect obstacles and impacts to the gate. If this is during opening, the gate will stop, if this is during closing the gate will stop, and then re-open.

When the motor detects any obstruction or impact during opening, the gate will stop and then return. During closing the gate will simply stop when detecting any obstacle or impact.

Rotate VR3 clockwise to increase the stall force, counter-clockwise to decrease. The factory default setting is midway, for any dial adjustment required above this check your gate is free rolling with no resistance (capable of being moved freely by 1 person).

For safety we strongly recommend that stall force mode is left Enabled (dip switch 7 is at the on position) do not switch dip switch 7 to the off position.

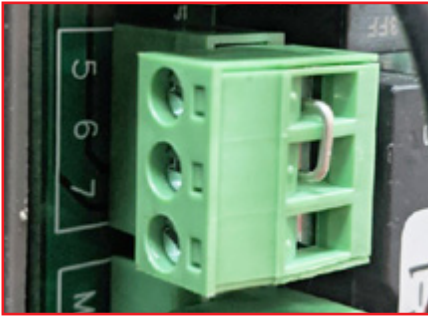

J1 Terminal:

Terminal 5: Common (Ground).

Terminal 6: Photocell input (Normally Closed). If no photocell is fitted use jumper between terminals 5 & 6.

Terminal 7: Extra power input +24VDC.



J7 Terminal:

Terminal 1: Optional External Open Push Button Switch. (Hard Wired keypad connection between terminals 1 & 4)

Terminal 2: Optional External Close Push Button Switch.

Terminal 3: Optional External Stop Push Button Switch.

Terminal 4: Common Terminal for All Optional Push Buttons.



J10 Terminal:

Limit Switch Wiring

OP: Open Circuit.

COM: Limit Switch Common Terminal.

CL: Closed Circuit.

How to secure a wire to the circuit board terminals

Ensure that power is off before completing any wiring



Using a screwdriver, loosen the screw on the side of the terminal.



insert the wire into the terminal



Tighten with a screwdriver to secure the wire in place.



J2 Terminal:

Factory Fitted (pre-wired)

Circuit board connection for low voltage power supply

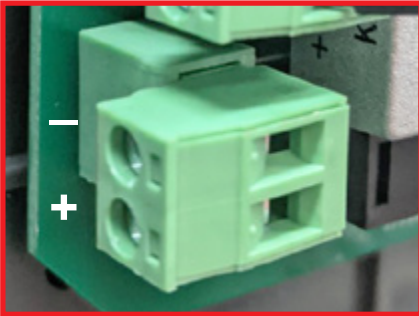

BAT Terminal:

Battery Backup Terminal

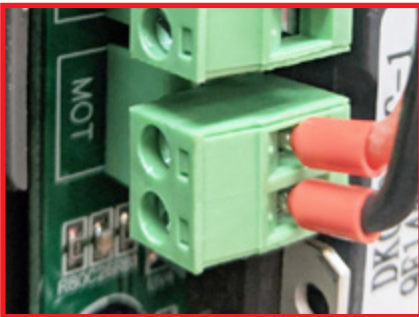

J4 (MOT) Terminal:

Factory Fitted (pre-wired)

DC motor wire connection (Red wire to top, black wire to bottom).



J8 Terminal:

24V DC warning light connection

Battery Backup Connection:

To operate this gate with battery backup you will need the **GTR206 Battery Backup Pack (sold separately)**

Battery backup can be useful in areas where mains power may be intermittent. Depending on the size and setup of your gate, batteries may be able to operate the gate up to ten times without being recharged.

To install battery backup, refer to the Fig 28 below.

Connect the pre-stripped black and red wires to the **BAT terminal** of the GTR061 circuit board and then connect to your GTR206 battery backup pack using the 2-pin plug supplied.

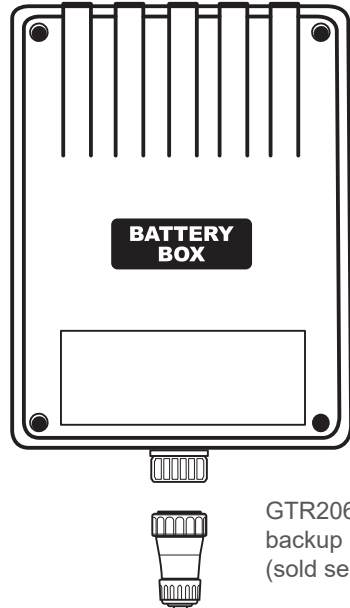

GTR206 battery backup pack (sold separately)

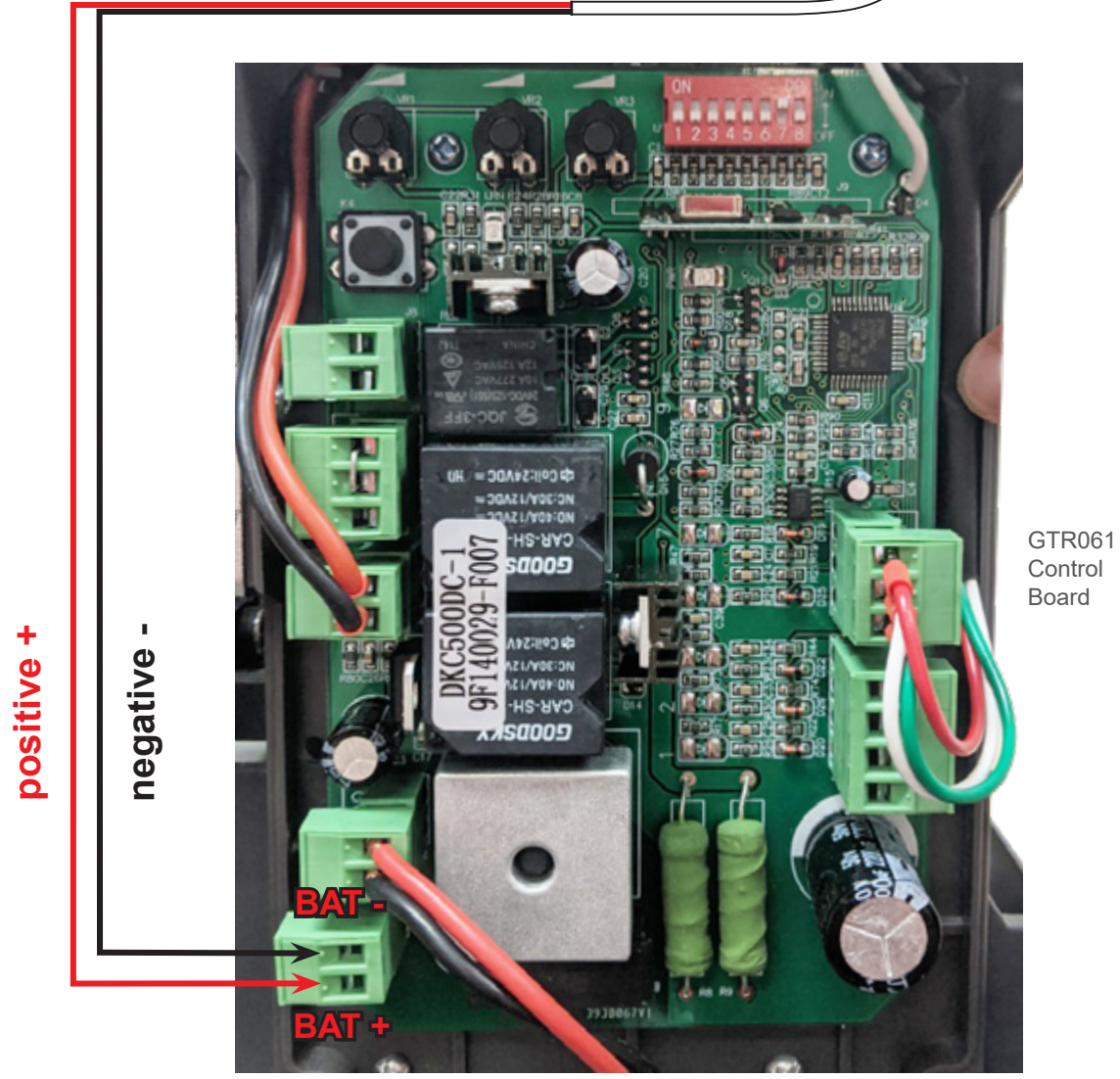

GTR061 Control Board

Fig 28

Solar Panel Connection:

To operate this gate with battery backup you will need the **GTR205 Solar Battery Pack** and **GTR049 Solar Panel** (sold separately)

Solar power is useful in areas where mains power is not readily available. The correct solar power and battery will depend on the size and setup of your gate, position of the panels and geographical area.

Note that performance may vary according the amount of sunlight per day, and condition of the batteries. To install solar power, refer to the Fig 29 below.

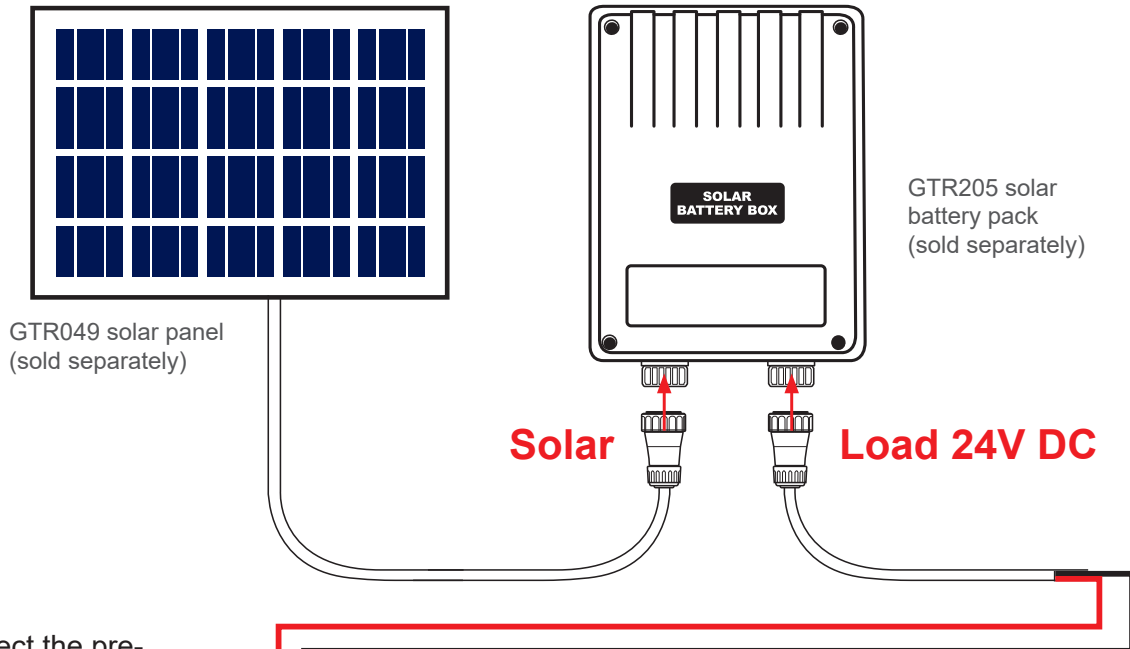

Connect the pre-stripped black and red wires to the BAT terminal of the GTR061 circuit board, and then connect to your GTR205 solar battery pack using the 2-pin plug supplied.

Lastly, connect the solar panel to the battery pack using the 2-pin plug supplied

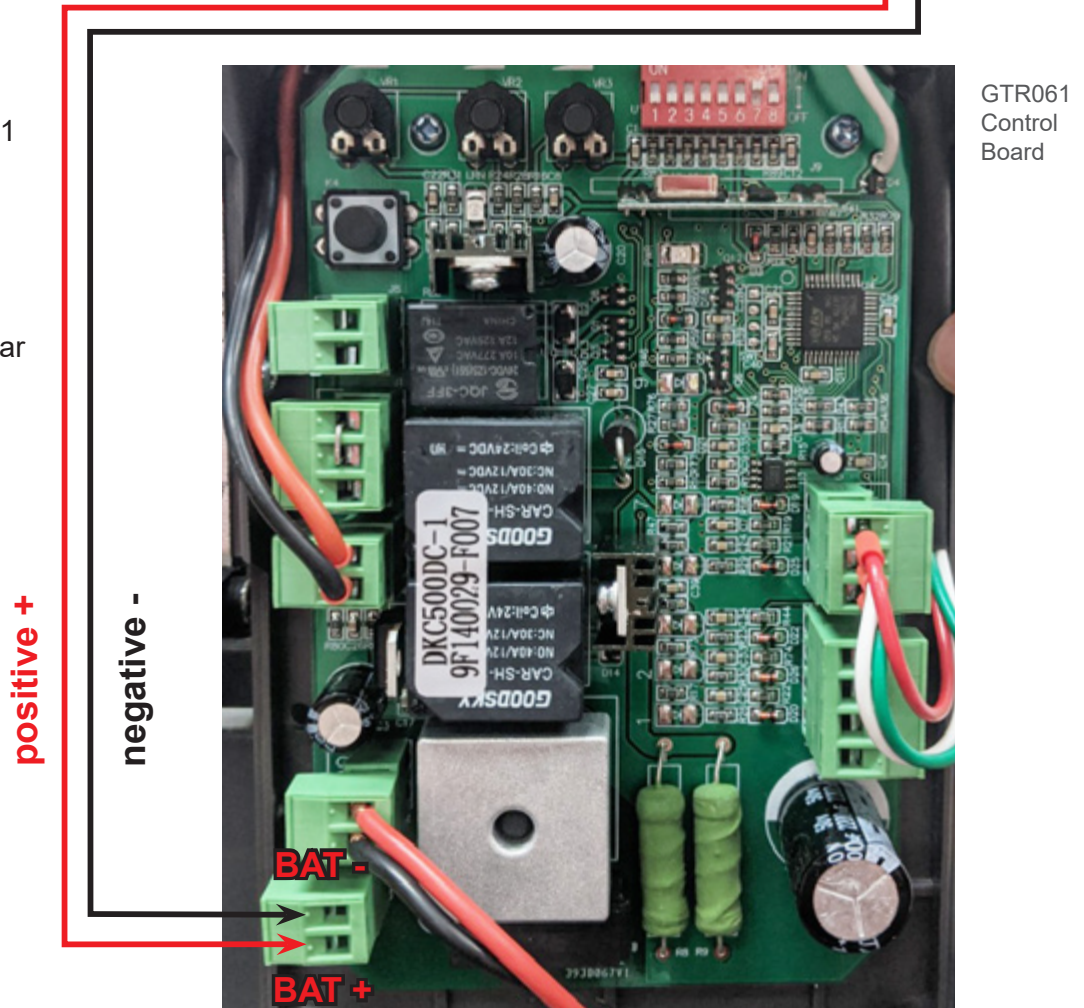

Fig 29

Troubleshooting: Ensure power is off before any modifications are made

Problems	Possible Reasons	Solutions
The gate cannot open or close normally, and LED does not light.	<ol style="list-style-type: none"> 1.The power is off. 2.Fuse is blown. 3.Control PCB is damaged 	<ol style="list-style-type: none"> 1.Switch on the power supply. 2. Licensed electrician Check the fuse (F1) (refer to page 20 fig 26) and replace if necessary. 3.Contact Richmond Wheel & Castor Co for replacement PCB
Remote control doesn't work.	<ol style="list-style-type: none"> 1. Remote control battery is flat. 2. Remote control is not paired correctly. 	<ol style="list-style-type: none"> 1.Check LED lights up when button is pressed. If not, change the remote-control battery (A27 battery required) 2. Repeat pairing procedure
The gate opens but cannot close.	<ol style="list-style-type: none"> 1. Photocell beam is interrupted. 2. Stall force is set too low 3. Photocell settings not correct. 4. Photocell not mounted correctly. 	<ol style="list-style-type: none"> 1. Check and remove any obstructions. 2. Increase stall force VR3 potentiometer. 3. If photocell is not connected, ensure the jumper wire is between 5 and 6 on the J1 terminal, and dip switch 6 is set to ON. If photocell is connected, remove jumper 5 and 6 and ensure the wiring is correct and dip switch 6 is set to OFF (N.C.). 4. Make sure photocell beams are correctly positioned.
Gate does not move when button is pressed, but motor makes a noise.	<ol style="list-style-type: none"> 1. Gate is out of alignment. 	<ol style="list-style-type: none"> 1. Connect in manual mode and check if it can be opened by hand. If cannot be easily opened, re-set up. 2. Contact Richmond Wheel & Castor Co for replacement PCB.
Gate does not stop at the limit switch when opening/closing.	<ol style="list-style-type: none"> 1.The gate direction is incorrect. 2. The limit switch is positioned incorrectly 3.The limit switch is damaged 	<ol style="list-style-type: none"> 1. Turn Dip switch 5 from ON or OFF (depending on its current setting) 2. refer to Pages 18 and 22. 3. Check wiring for any damage. Contact Richmond Wheel & Castor for a new limit switch if required.
Current leakage switch tripped.	<ol style="list-style-type: none"> 1. Short circuit in the power supply line. 	<ol style="list-style-type: none"> 1. Licensed electrician to check wiring.
Remote control working distance is too short.	<ol style="list-style-type: none"> 1.Signal is blocked or too much interference. 	<ol style="list-style-type: none"> 1. Connect external receiver antenna 1.5 meters above ground. 2. check remote control battery
Gate does not fully open or close	<ol style="list-style-type: none"> 1. Motor output force is too low. 2. Stall force is too low. 3. Gate meets obstacle. 	<ol style="list-style-type: none"> 1. Increase VR2 potentiometer. 2. Increase VR3 potentiometer. 3. Remove the obstacle.

For support or assistance with troubleshooting, visit richmondau.com/gate-motor-support/

Or ring your local Richmond Wheel & Castor Branch

AU: 03 9070 5713 **NZ:** 0800 61 71 81 **International:** +613 9551 2233

Clearing Remote Controls:

- To delete all paired remote controls, Press and hold the learning button K4 for approximately 8 seconds. Once the indicator light LRN turns off, all remote controls previously paired will be deleted.

Pairing Remote Controls:

- While the motor housing cover and clear plastic PCB cover are removed,
- Press the learning button K4 on the control board, until the indicator light LRN turns on, then release the button.
- While the light is on, press the first button on the remote control twice within 4 seconds, the LRN will flash repeatedly and then turn off when remote control is paired.

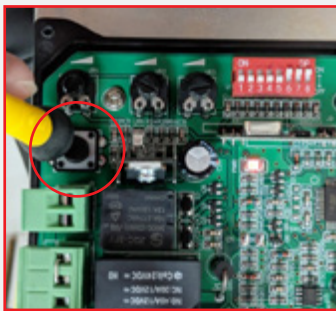

Press and hold the learn button (K4) until the Learn LED flashes ON.



While the light is on, press the first button on the remote control twice.



The Learn LED will flash repeatedly and then turn OFF. when the remote is paired.



Technical Support:

For support or assistance with installing your gate motor, visit richmondau.com/gate-motor-support/

Or ring your local Richmond Wheel & Castor Branch

AU: 03 9070 5713 **NZ:** 0800 61 71 81 **International:** +613 9551 2233

Richmond Wheel & Castor Co declines all responsibility for any consequences resulting from improper use of the product, or use which is different from that expected and specified in the present documentation.

Richmond Wheel & Castor Co declines all responsibility for any consequences resulting from failure to observe Good Technical Practice when constructing closing structures (door, gates etc.), as well as from any deformation which might occur during use.

Additional Drawings and Measurements:

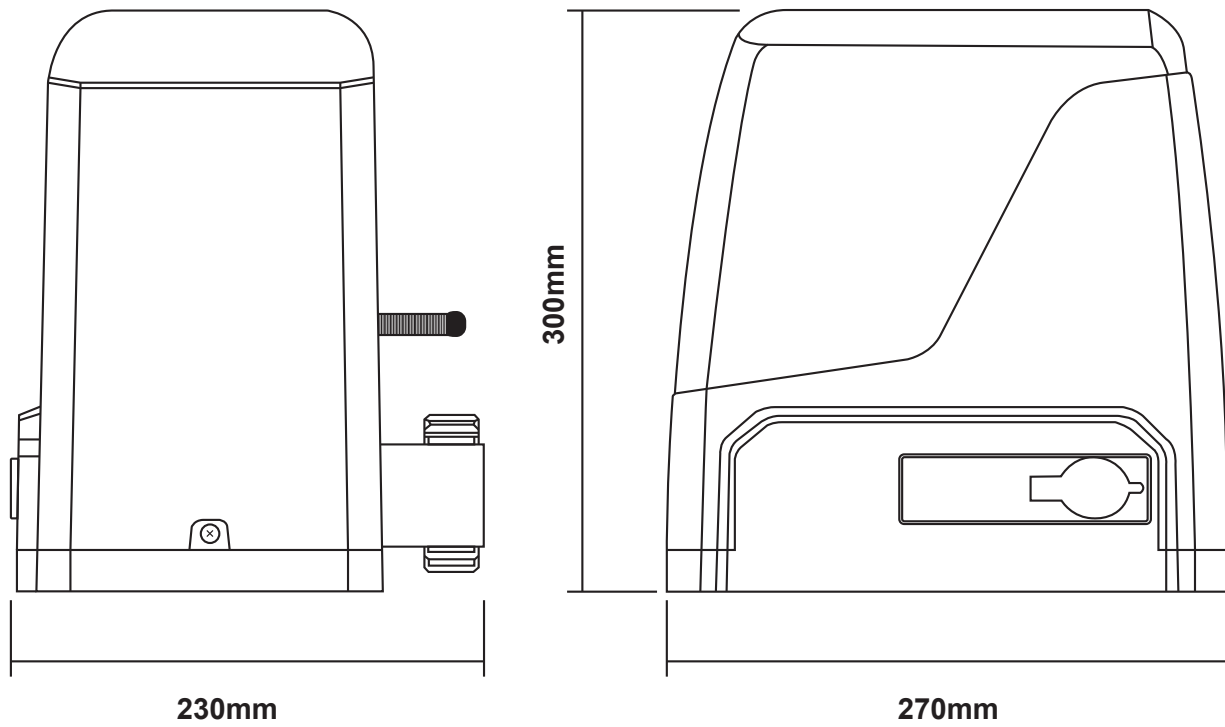

Fig 30

Maintenance:

Under normal operation, the gate should be checked every 6 months:

- Check and tighten anchor bolts
- Check for loose and corroded wires.
- Ensure your gate can still move smoothly by hand by placing the gate into manual mode using the manual release key.