

MARTIN DC2500e/DC3700e GARAGE DOOR OPENER SYSTEM

DC2500e Chain Drive: Doors up to 10'(3100) High. DC3700e Belt Drive: Doors up to 14' (4300) High.



INSTRUCTION MANUAL

For Installation on residential garage doors:

- All brands* - Center mount only
- Martin door models WL, RA, HT, FL SL, SP CM, RI, MO, CH - Center or side mount
- Martin Electric (combination) models WLE, HTE, CME, RAE, FLE, CHE - Center or side mount

- See page 5 for IMPORTANT INSTALLATION, MAINTENANCE & SAFETY INSTRUCTIONS
- This instruction manual features “Low Risk” Martin Finger Shield Garage Doors
- *WARNING! The back page helps you determine if your garage door is “HIGH RISK”.

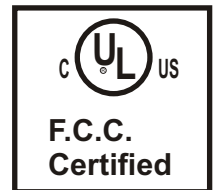



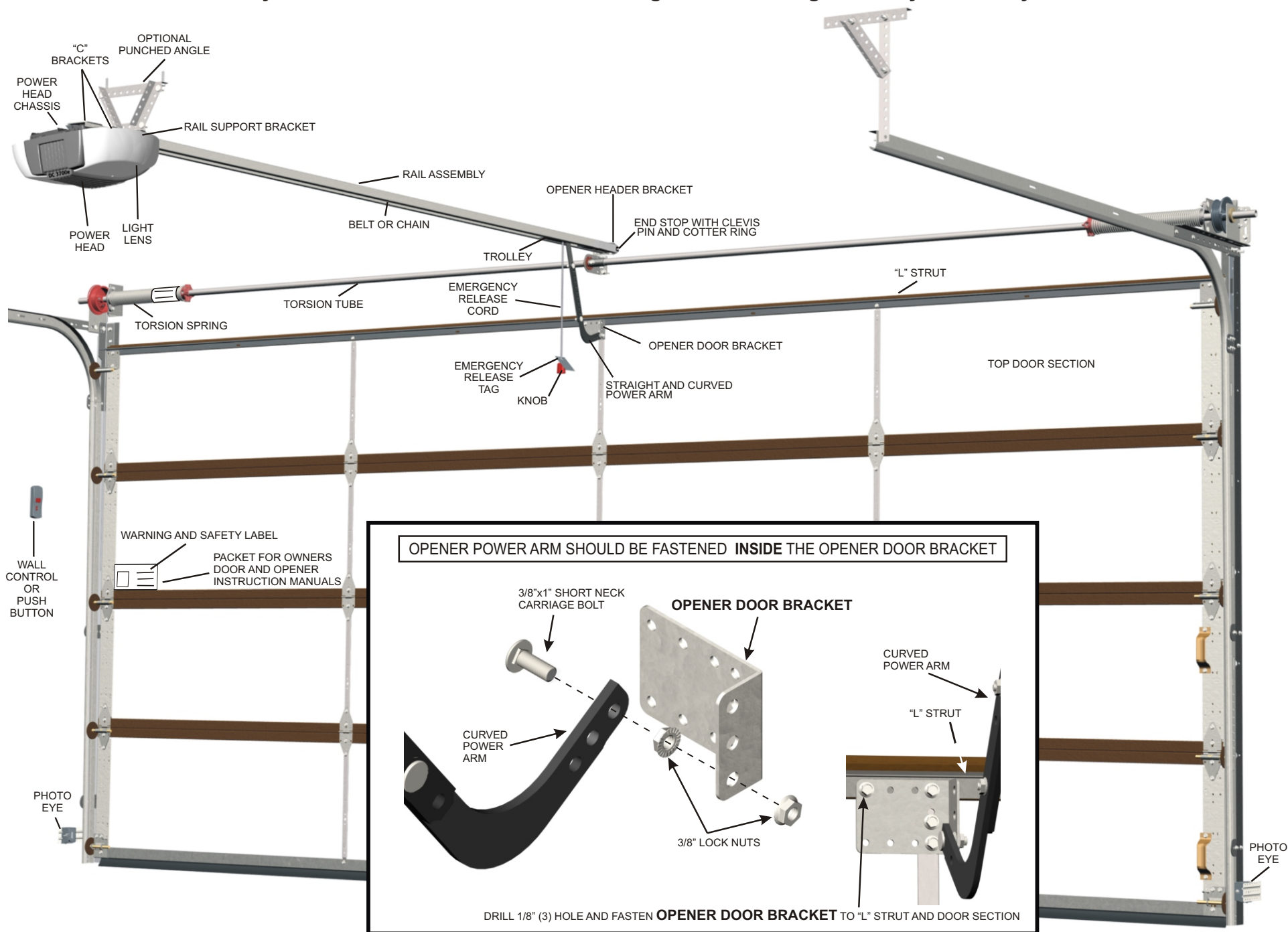

MARTIN CENTER-MOUNT OPENER INSTALLATION

- May be mounted off-center for Martin Finger Shield Garage Door Systems only -

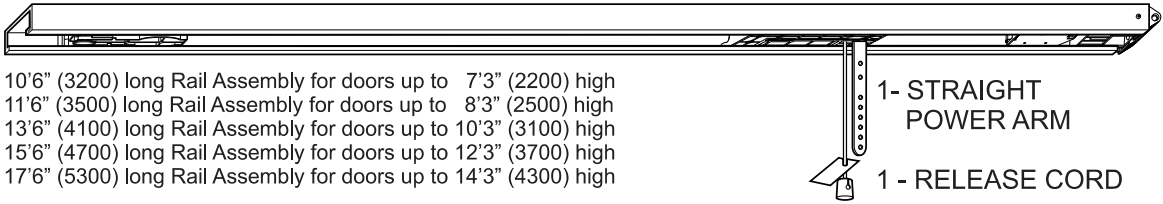

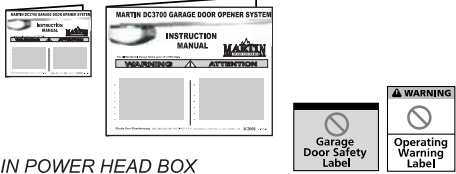
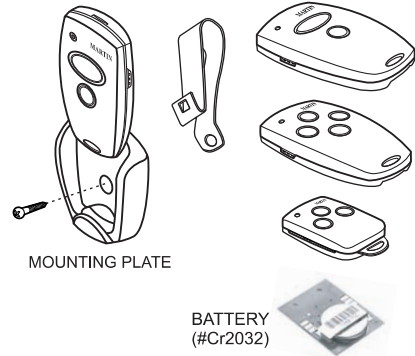
MARTIN DC3700e/DC2500e GARAGE DOOR OPENER PACKAGE CONTENTS: 1 - POWER HEAD BOX, 1 - RAIL ASSEMBLY BOX

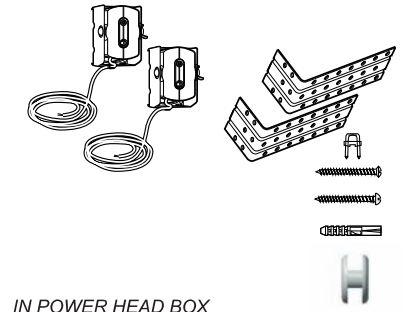
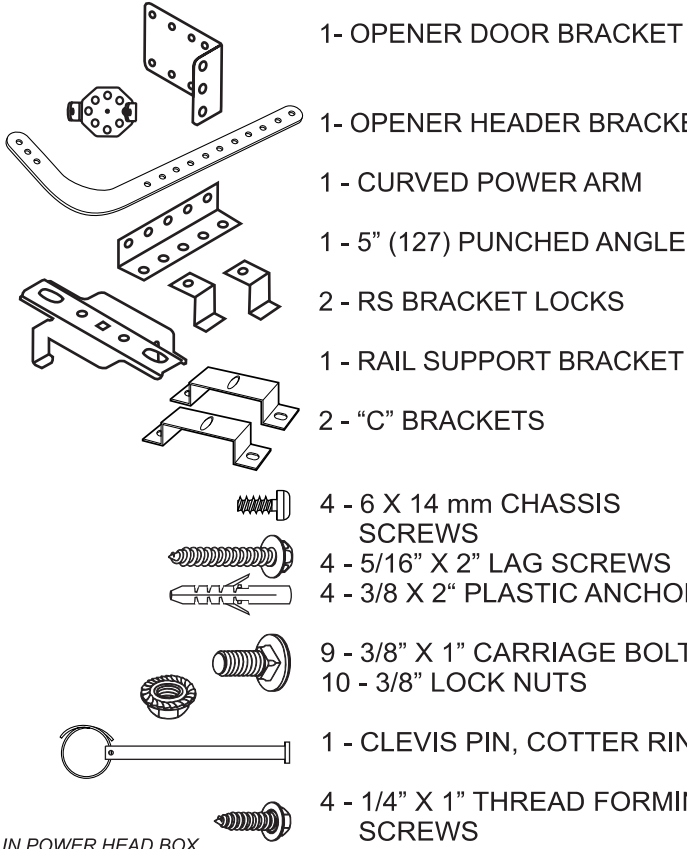
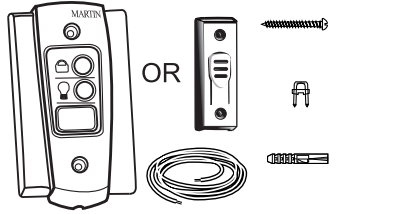
PICTORIAL		DESCRIPTION	PICTORIAL		DESCRIPTION
DC3700e	DC2500e		 <p>1- RAIL ASSEMBLY</p> <p>1- STRAIGHT POWER ARM</p> <p>1- RELEASE CORD</p> <p>10'6" (3200) long Rail Assembly for doors up to 7'3" (2200) high 11'6" (3500) long Rail Assembly for doors up to 8'3" (2500) high 13'6" (4100) long Rail Assembly for doors up to 10'3" (3100) high 15'6" (4700) long Rail Assembly for doors up to 12'3" (3700) high 17'6" (5300) long Rail Assembly for doors up to 14'3" (4300) high</p> <p>IN RAIL ASSEMBLY BOX</p>		
<p>IN POWER HEAD BOX</p>  <p>1- POWER HEAD</p>			 <p>1- FULL SIZE INSTRUCTION MANUAL 1- MINI SIZE INSTRUCTION MANUAL (PLACE IN PLASTIC PACKET ON BACK OF MARTIN GARAGE DOOR) 2- WARNING LABELS</p> <p>IN POWER HEAD BOX</p>		
 <p>1- 2 BUTTON MINI TRANSMITTER W/ VISOR CLIP</p> <p>4 BUTTON MINI TRANSMITTER WITH VISOR CLIP (OPTIONAL)</p> <p>3 BUTTON MICRO TRANSMITTER (OPTIONAL)</p> <p>MOUNTING PLATE (OPTIONAL)</p> <p>BATTERY (#Cr2032)</p> <p>1- PROGRAMMING TINE</p>			 <p>WIRELESS KEYLESS ENTRY (OPTIONAL)</p> <p>KEY SWITCH (OPTIONAL)</p> <p>VAULT KEY RELEASE (OPTIONAL)</p> <p>IN POWER HEAD BOX</p>		
<p>IN POWER HEAD BOX</p>  <p>2- PHOTO EYES W / WIRE</p> <p>2- MOUNTING BRACKETS</p> <p>20- STAPLES</p> <p>4- TAPERED HEAD SCREWS</p> <p>4- ROUND HEAD SCREWS</p> <p>4- PLASTIC ANCHORS</p> <p>6- CONCEALED PHOTO-EYE WIRE RIVETS (Dc3700e ONLY)</p>			 <p>1- OPENER DOOR BRACKET</p> <p>1- OPENER HEADER BRACKET</p> <p>1- CURVED POWER ARM</p> <p>1- 5" (127) PUNCHED ANGLE</p> <p>2- RS BRACKET LOCKS</p> <p>1- RAIL SUPPORT BRACKET</p> <p>2- "C" BRACKETS</p> <p>4- 6 X 14 mm CHASSIS SCREWS</p> <p>4- 5/16" X 2" LAG SCREWS</p> <p>4- 3/8 X 2" PLASTIC ANCHORS</p> <p>9- 3/8" X 1" CARRIAGE BOLT</p> <p>10- 3/8" LOCK NUTS</p> <p>1- CLEVIS PIN, COTTER RING</p> <p>4- 1/4" X 1" THREAD FORMING SCREWS</p> <p>IN POWER HEAD BOX</p>		
<p>IN POWER HEAD BOX</p>  <p>1- WALL CONTROL (DC3700e) OR PUSH BUTTON (DC2500e)</p> <p>2- TAPERED HEAD SCREWS</p> <p>10- STAPLES</p> <p>2- PLASTIC ANCHORS</p> <p>1- 30' (9144) ROLL OF WIRE</p>					

WARNING



TO REDUCE THE RISK OF SEVERE INJURY OR DEATH, READ AND FOLLOW ALL INSTRUCTIONS

Do not install this opener or any other opener on "HIGH RISK" garage doors that may cause severe injury, entrapment or death! See back page for serious injuries which may occur if "HIGH RISK" areas are left uncorrected.

Martin Finger Shield Garage Doors are "Low Risk".

IMPORTANT INSTALLATION INSTRUCTIONS

- **Untrained or Negligent** Installing, Adjusting and Servicing can be Dangerous! The garage door springs and related parts can cause serious injury or death! IF YOU ARE UNSURE, CALL A TRAINED MARTIN DOOR DEALER!
- **Garage door** should be balanced and easy to open and close by hand.
- **Locks** should be disabled and pull down ropes should be removed.
- **Locate** wall control/push button within sight of door, at min. height of 5' (1520) so small children cannot reach it, and away from all moving parts of door. See Step 8.
- **Emergency release tag** should be installed above knob and adjusted to about 6' (1830) above the floor.
- **Risk of electrical shock** is explained in Step 10. Do not connect opener to source of power until instructed to do so.
- **Entrapment and warning labels** should be installed next to the wall control/push button as explained in Step 14.

IMPORTANT MAINTENANCE & SAFETY INSTRUCTIONS

- **Monthly**, check the opener's down cycle safety reverse. The door must reverse when it contacts a 1 1/2" (38) high object (or a 2X4 board laid flat) on the floor, in line with the door opener. A closing door must also reverse if the photo eyes are interrupted. See Steps 12,13.
- **Always** keep the moving door in sight and away from people and objects until it is completely closed. NO ONE SHOULD CROSS THE PATH OF THE MOVING DOOR.
- **NEVER GO UNDER A STOPPED, PARTIALLY OPEN DOOR**
- **Do not allow children** to operate or play with the garage door opener controls. Keep all remote controls away from children.
- **The emergency release** should only be used when garage door is in the closed position. Weak or broken springs may cause door to fall if released in the open position, increasing the risk of severe injury or death. Use caution when using the release with door open.
- **Monthly** visually check the lift cables, spring assembly, hardware, etc. for wear and stability.
- **If the Safety Reverse** or any other part of the garage door and opener system do not work properly, or if you do not understand, call a trained Martin Door Dealer.

SAVE THESE IMPORTANT INSTRUCTIONS

THE FOLLOWING ITEMS ARE HELPFUL TO COMPLETE A SATISFACTORY MARTIN GARAGE DOOR AND OPENER INSTALLATION:

1. Hammer
2. Level (magnetic)
3. Hacksaw
4. Wire Cutters
5. 18' (5.5) measuring tape
6. Socket wrench set for 7/16" (11), and 9/16" (14) with 3" (76) extension
7. Regular and phillips screwdriver
8. End wrench set for 7/16" (11), and 9/16" (14)
9. 10/40 motor oil lubricant
10. Wax lubricant (paraffin, candle, etc.)
11. Cordless drill with 1/8" (3), 13/64" (5), 1/4" (6) bits plus 1/4" and 3/8" (6 and 10) masonry bits
12. Step ladder (not shown)
13. Pencil
14. Punched angle opener hanger: 8' X 1-1/4" X 1-1/4" (2440 X 32 X 32)
15. Needle nose plier and wire stripper.

ALL MEASUREMENTS IN PARENTHESIS () ARE MILLIMETERS IN THIS INSTRUCTION MANUAL.

NOTE: Bolts, lock nuts and lag screws for fastening the punched angle are furnished with the door opener hardware fasteners.

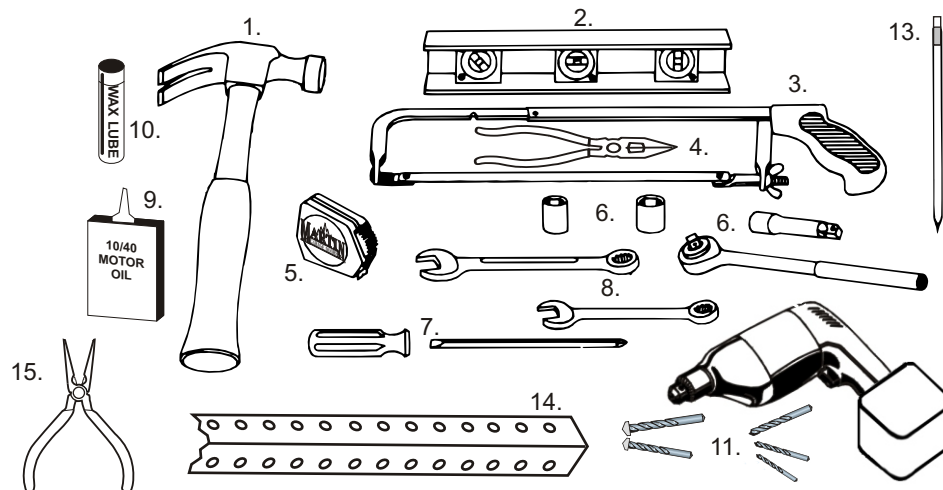

OPENER DOOR BRACKET GUIDELINES

ONLY Martin Finger Shield Garage Door Systems allow you to choose center, off center or side mounting for a safer, more attractive opener installation. See page 2 and 3

WARNING! Other brand doors are designed for center mounted openers only. Off center or side mounted installations may result in other brand doors binding, side shifting, twisting, and falling, as the lift cables may detach from the cable drums.

A Martin Opener requires 1 1/2" (38) more clearance than the required garage door clearance.

Opener Door Bracket Exception

Martin Doors over 18'2" (5540) wide, high wind Martin Doors and Martin wood doors over 10'2" (3100) wide use 3 1/4" (83) wide "U" struts that fasten over top roller brackets. The opener door bracket fastens on top of this "U" strut, at any location with four 1/4" (6) thread forming screws. With the door in the closed position, fasten straight power arm to reversed curved power arm (curve may be cut off). The reversed curved power arm is first fastened to opener door bracket. Fasten power arms together at about a 45° angle for smooth opening and closing of door. For low clearance installations, try using the straight power arm only for fastening to the opener door bracket.

See Figures A,B

OPTIONAL POWER ARM ANGLE

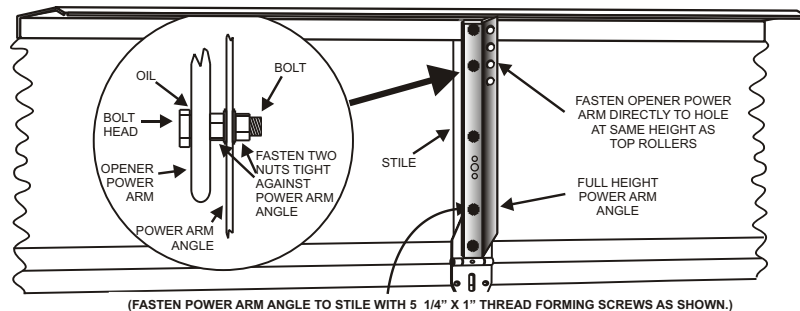
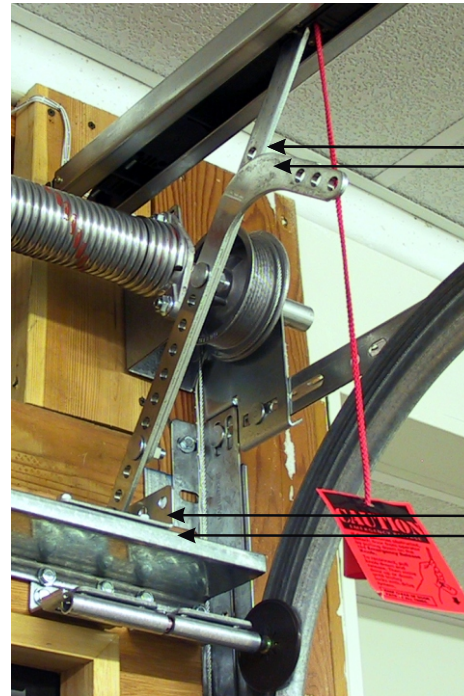

FIGURE A



SIDE MOUNT 12" (305) CLEARANCE

ONE STRAIGHT POWER ARM AND ONE REVERSED CURVED POWER ARM. BOTH FASTENED TOGETHER AT A 45° ANGLE.

MARTIN OPENER DOOR BRACKET FASTENED TO 3 1/4" (83) WIDE "U" STRUT

FIGURE B

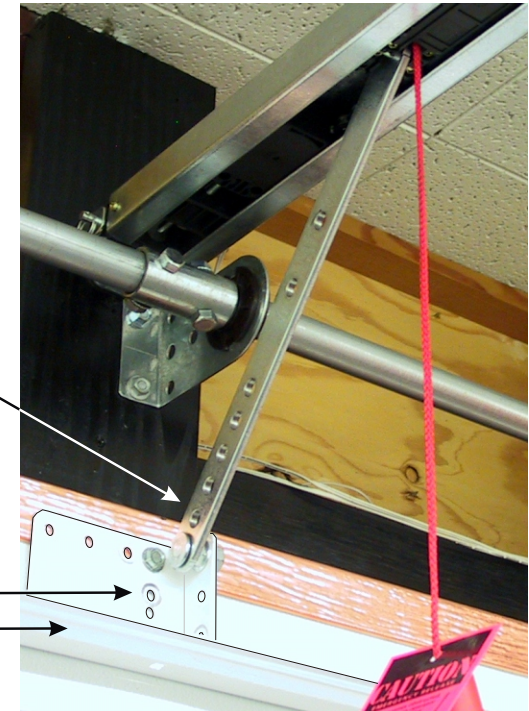

CENTER MOUNT 8" (204) LOW CLEARANCE

ONE STRAIGHT POWER ARM FASTENED AT A 45° OR MORE ANGLE

MARTIN OPENER DOOR BRACKET FASTENED TO CENTER STILE AND REVERSED "L" STRUT.

INSTALLATION INSTRUCTIONS FOR MARTIN GARAGE DOOR OPENER SYSTEMS

THESE INSTRUCTIONS ARE INTENDED FOR PROFESSIONAL GARAGE DOOR OPENER INSTALLERS. READ THROUGH THE COMPLETE INSTRUCTION MANUAL AND APPLICABLE SUPPLEMENTAL INSTRUCTIONS BEFORE BEGINNING.

STEP 1 FASTENING THE OPENER DOOR BRACKET

Study "Opener Door Bracket Guidelines" on page 2, 3, and 6.

Decide if the opener will be mounted to the center, off center or side of the garage door. Center and off center mounted openers always require a "full width" top strut on the door. If side mounted, Martin Doors up to 12'2" (3700) wide may or may not require a top strut.

Fasten the opener door bracket under the top roller bracket for side mounting or on the stile and strut for center/off center mounting. Fasten with 1/4" x 1" Thread Forming Screws. See "Exception" on page 6.

Fasten the curved power arm to the opener door bracket with 3/8" X 1" short neck carriage bolt and two 3/8" lock nuts as shown in the "Opener Door Bracket Guidelines" on page 2 and 3.

Raise the curved opener power arm straight up and touch the torsion tube or spring. Make a vertical mark on header, in line with the power arm. This mark will be the vertically centered location for the opener header bracket. See Figure 1

Note: To hold the top of the curved power arm from falling down, temporarily tie it to the top of the door bracket or strut. See Figure 1

STEP 2 FASTENING THE OPENER HEADER BRACKET

Make a horizontal mark on the header 2" (51) above the highest movement of the door as it opens. See figure 2.

The following are approximate measurements above the top of a closed door to the horizontal mark on the header:

- **11 1/2" (292)** for 12" (305) regular clearance track.
- **6 1/2" (165)** for 8" (203) low clearance track.
- **5" (127)** for 4 1/4" (108) low clearance track.
- **3 1/2" (89)** for 2 1/2" (64) low clearance track.

Fasten the opener header bracket to the header with two 5/16" X 2" lag screws. The vertical and horizontal marks are the "centered location" marks.

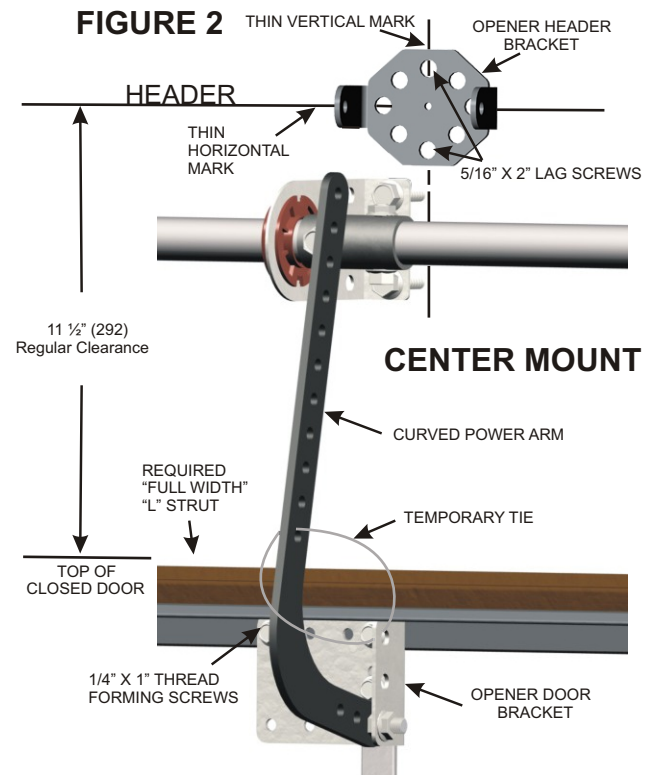
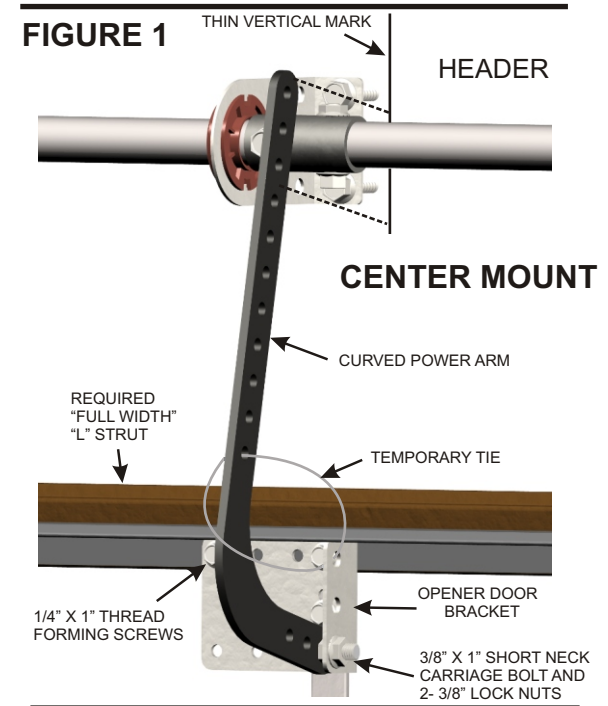

STEP 3

FASTENING THE RAIL ASSEMBLY TO THE POWER HEAD

Place the rail assembly onto the power head chassis by lining up the sprocket assembly opening with motor shaft. Make sure the shaft engages teeth inside sprocket assembly. Press rail assembly down firmly onto shaft and power head chassis. **DO NOT HAMMER!**

Fasten 2 "C" brackets over rail assembly and onto chassis. Flanges on "C" brackets must fit into the four recessed areas on chassis. The rail assembly must be at a right angle to the power head for the "C" brackets to fit properly. See Figure 3

Insert 6 X 14 mm chassis screws through "C" bracket holes and into chassis holes, and tighten screws by hand with a phillips screw driver. The "C" brackets must firmly hold rail assembly to chassis. See Figures 3, 4.

Do not remove tape around the trolley and straight power arm until Step 9. The trolley has been taped at the correct location so that the belt or chain position tab will activate the position switch, and opener computer correctly. The activation begins when the opener opens the door, from the closed position, for the first time. See Figure 5

STEP 4

FASTENING THE RAIL ASSEMBLY TO THE OPENER HEADER BRACKET

Place power head on stepladder, positioning front of rail assembly on torsion tube (or on torsion spring if side mounted) for stability. See Figure 5

Position rail assembly end-stop within the opener header bracket and insert clevis pin through the end-stop and opener header bracket. Attach the cotter ring to the end of the clevis pin. See Figure 6

FIGURE 3

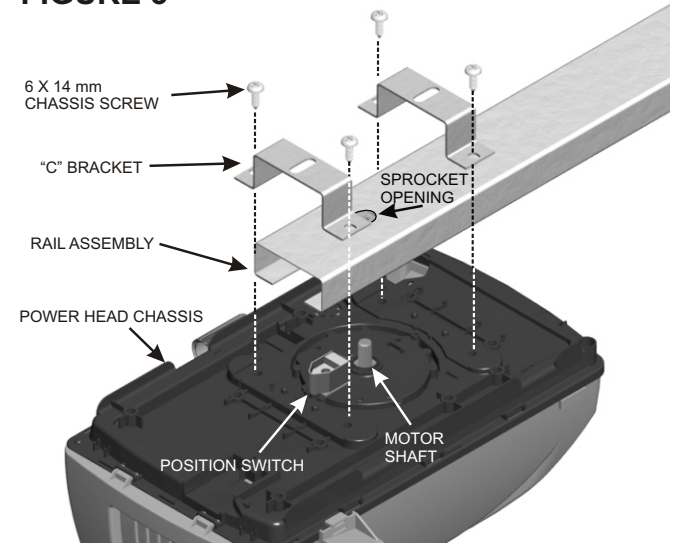

FIGURE 4

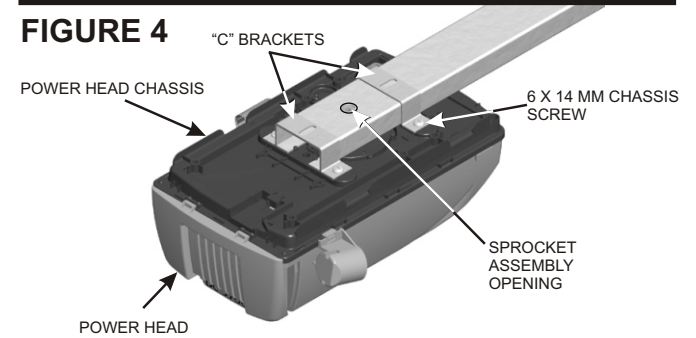

FIGURE 6 (Top View)

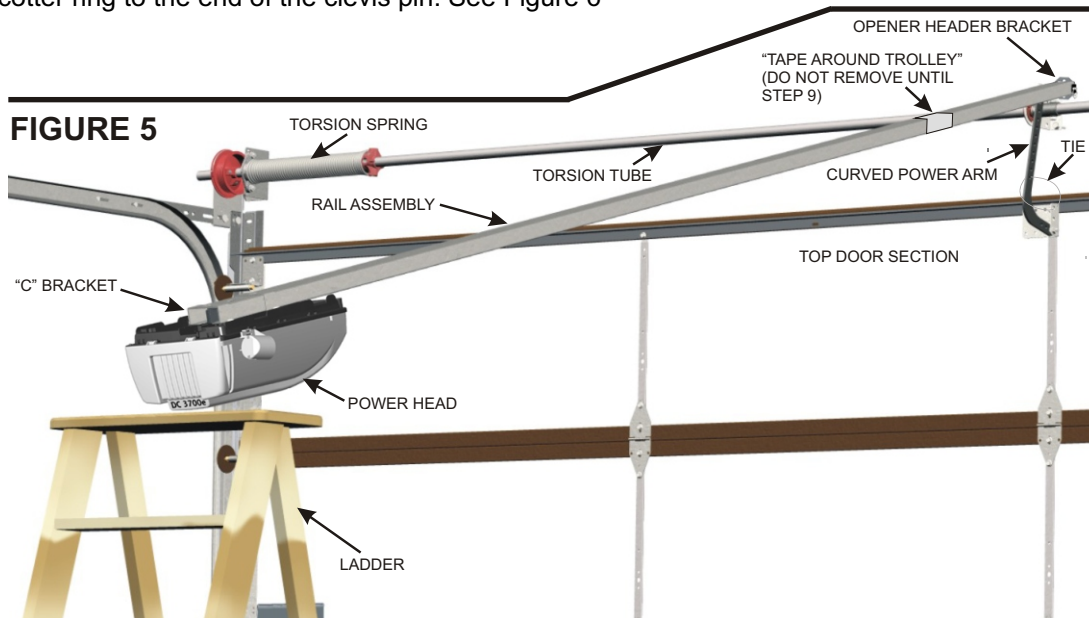
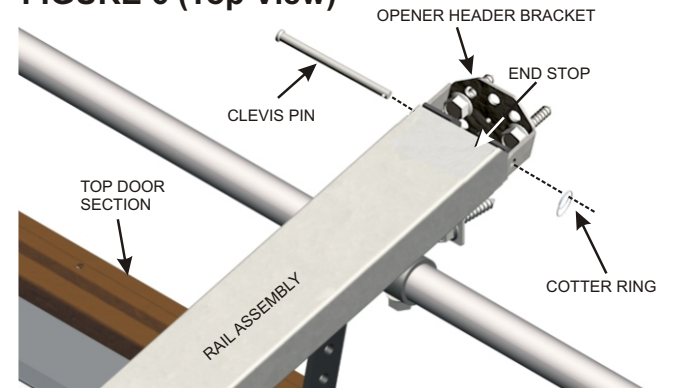

FIGURE 5

**STEP 5
MOUNT OPENER TO CEILING**

Raise the opener power head high enough to allow the door to be fully opened. **OPEN DOOR BY HAND.** Set a 1 1/2" (38) high object on the top part of the door, under the rail assembly. Center the rail assembly with the opener door bracket. See Figure 11

Twist rail support bracket onto rail assembly. See Figures 7 and 8

Slide the rail support bracket forward or backward on the rail assembly to the best location for fastening to the ceiling. See Figure 8

Fasten the 5" (127) punched angle and the rail support bracket locks to the rail support bracket. See Figure 9

Fasten optional punched angle diagonally from 5" (127) punched angle to ceiling for correct stability. See Figure 11

NOTE: If clearance is limited, the rail support bracket can be fastened directly to the ceiling with no 5" (127) punched angle or rail support bracket locks. See Figure 8

Fasten one extra rail support bracket to center part of rail furnished for doors 10'(3100) to 12'(3700) high. Fasten two extra rail support brackets spaced equally apart on rails furnished for doors 14'(4300) high. See Figure 11A

FIGURE 7

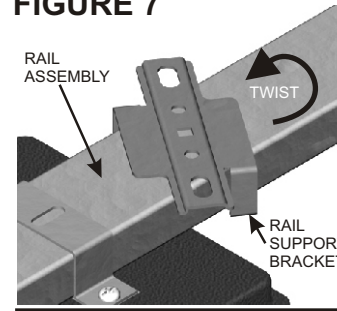

FIGURE 8

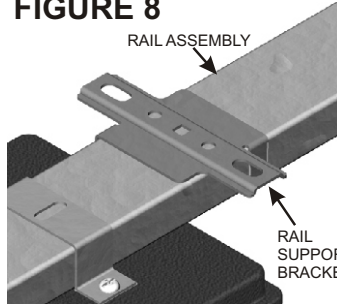

FIGURE 9

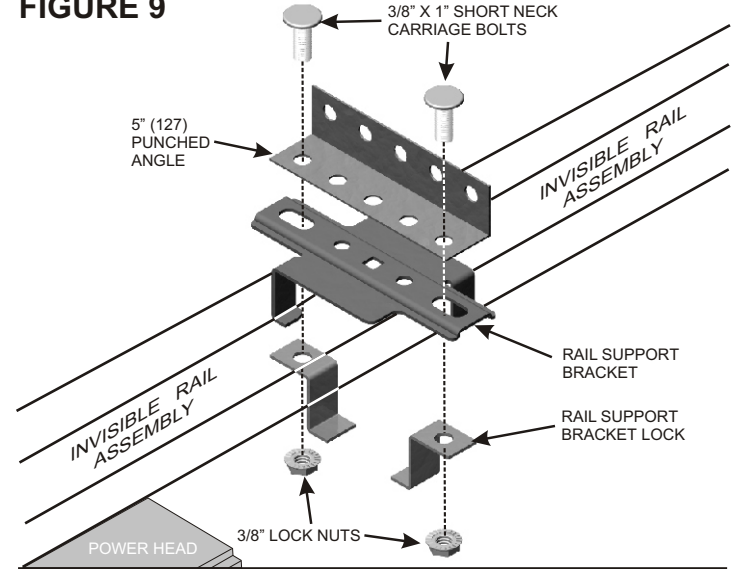

FIGURE 10

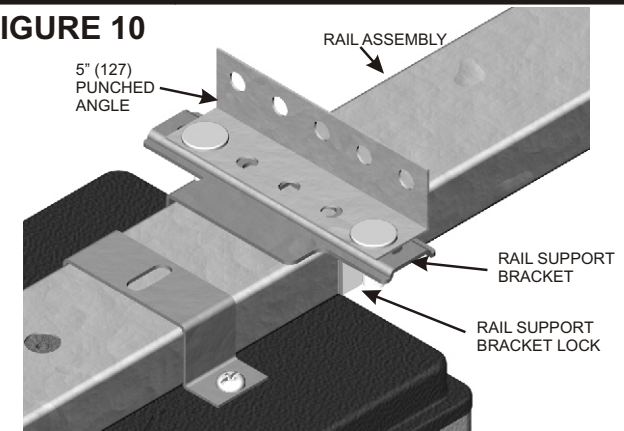

FIGURE 11A

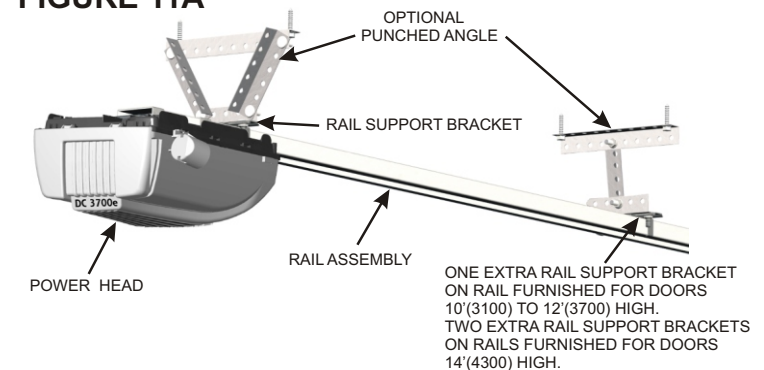
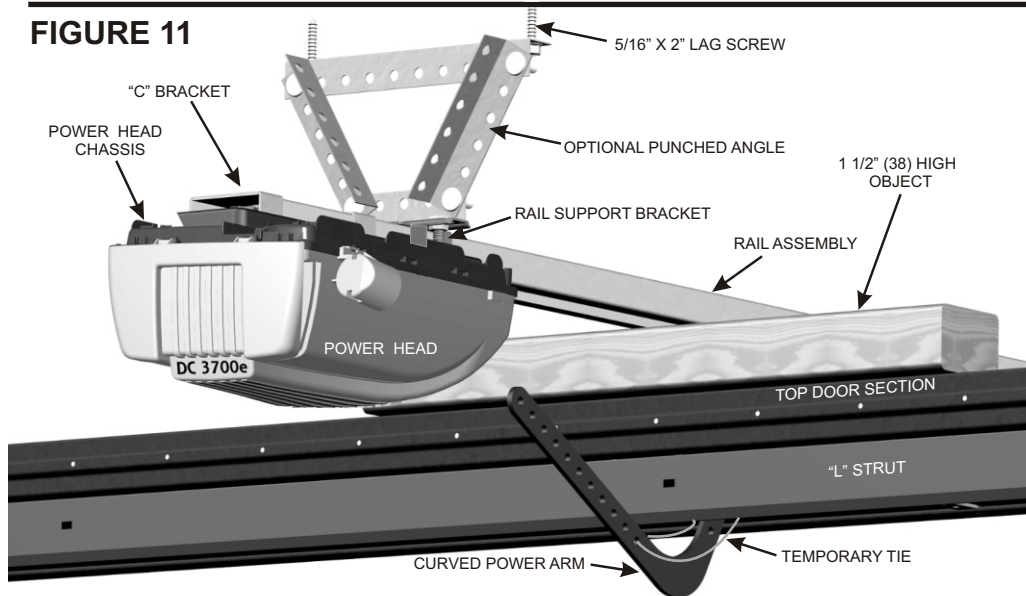

FIGURE 11



**STEP 6
LIGHT BULBS AND LIGHT LENSES**

Twist 2 light bulbs (1 for DC2500e), maximum 60W, into light bulb sockets.

Position light lens tabs with corresponding slots in power head and chassis and snap into place. Two screws are also furnished to fasten bottom part of DC3700e light lenses. See Figure 12A or 12B

**STEP 7
PHOTO EYES SAFETY SYSTEM**

IMPORTANT! CLOSE DOOR BY HAND TO FINISH INSTALLATION!

MOUNTING PHOTO EYES DIRECTLY TO SIDE WALL:

Locate mounting position 3" (76) to 5" (127) above the floor. Mark and drill 1/16" (1.5) pilot hole into wall. (If mounting to concrete or drywall instead of wood, use anchors provided and drill 3/16" (5) pilot hole).

Fasten tapered-head screw into wall. Do not tighten screw. Allow screw head to protrude (approximately 3/8" (9.5)) from wall.

Position the top slot hole on the back of the photo eye holder onto screw and push down to lock in place. See Figure 13

Fasten tapered head screw through the curved channel slot at the bottom of the photo eye holder after drilling correct pilot hole. Repeat process for other photo eye and photo eye holder. See Figure 13

Align photo eyes so they face each other. In Step 12 you will be instructed to check the alignment. Tighten wing nut on each photo eye by hand. See Figure 14

MOUNTING PHOTO EYES TO BRACKET:

Locate mounting position 3" (76) to 5" (127) above the floor for photo eye brackets. Brackets can be mounted in any position as long as photo eye beam has a clear path from one side of door to the other side after mounting. See page 3.

Mark and drill two 1/16" (1.5) pilot holes into wall. (If mounting to concrete or drywall instead of wood, use anchors provided and drill two 3/16" (5) pilot holes).

Using round-head screws provided, fasten bracket to wall. Attach photo eye to bracket by aligning tabs and center pin and snapping into place. Photo eye wiring should exit downward. Repeat process for other bracket. See Figures 15 and 16

Align photo eyes so they face each other. In Step 12 you will be instructed to check the alignment. Tighten wing nut on each photo eye by hand. See Figure 16

ATTENTION: In 2-door installations, the "Receiver" photo eyes (as marked on each of the photo eyes) should be mounted on the far outsides. The "Transmitter" photo eyes should be mounted on the insides, to avoid 2 beams shining into 1 receiver.

FIGURE 12A

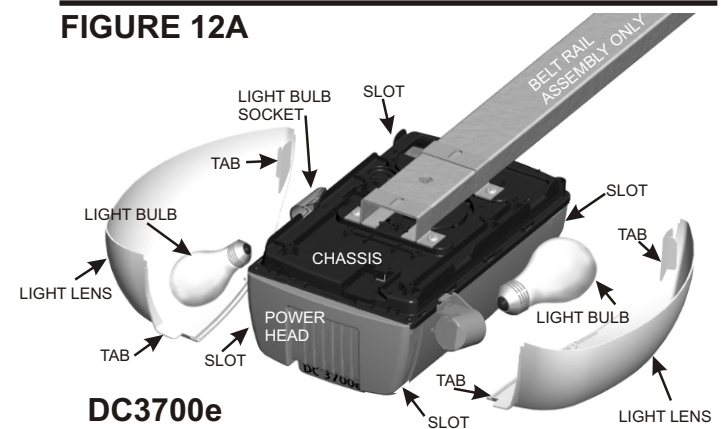

FIGURE 12B

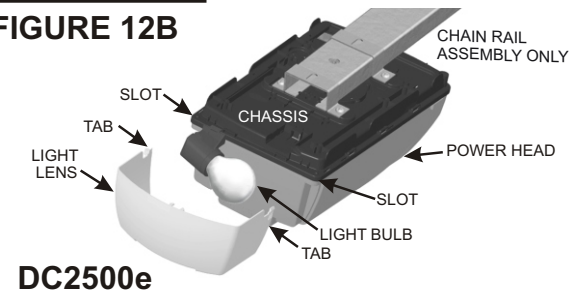

FIGURE 13

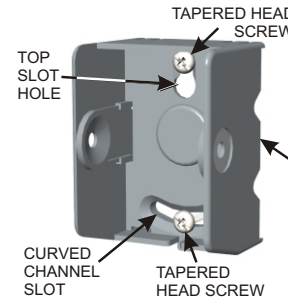

FIGURE 14

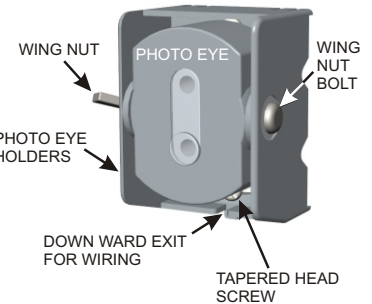

FIGURE 15

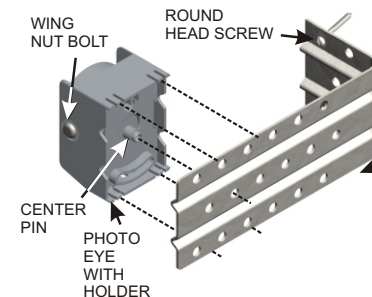
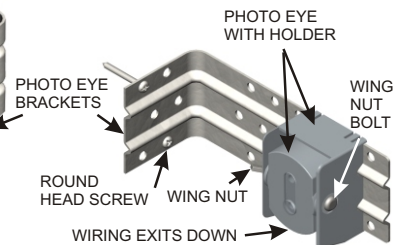

FIGURE 16



STEP 7 CONTINUED

CONNECTING WIRES TO POWER HEAD

Route wiring through clip on bottom of photo eye holder, then run wires along wall and ceiling to power head chassis. Use provided staples to fasten wiring to wall, joists and/or ceiling. Do not pinch wiring.

NOTE: As an alternative, the wiring can be routed along the top of the rail assembly, or along the outside of the garage door track. Be sure the wiring is routed away from all moving parts of door and rail assembly. (For Dc3700e with Martin Door applications, see concealed photo-eye wire attachment kit instructions).

Open the control panel cover by gently pulling on the 2 tabs, allowing the cover to hang open. To remove, pull carefully on the cover corner near one of the hinges. Do not twist cover or hinges may break. See Figure 23

Route wires through wire guide at top of power head chassis into terminal area of control panel. Separate the dbl. wire from each photo eye into two single wires: 1) the white wire and 2) the black striped wire. See Figure 17

Remove about 1/2" (13) of insulation from the end of each of the four single wires. Twist the white wire ends together and twist the black striped wire ends together. Insert twisted white wire ends firmly into terminal hole #1 by pushing directly into hole. If wires are difficult to insert, a screwdriver may be used to depress the terminal tab while inserting the wires. To remove wiring, depress terminal tab again and pull wiring out. Repeat procedure for the twisted black striped wire ends, except insert them into terminal hole #2. See Figure 17

**STEP 8
WALL CONTROL / PUSH BUTTON**

The wall control/push button will allow you to control your garage door from inside the garage. It must be mounted within sight of the garage door, clear of all moving garage door parts or any associated parts, at least 5' (1520) above the floor, out of children's reach. The wall control/push button should only be used when the door area is free of people or any obstructions.

FASTENING THE WALL CONTROL:

Attach wiring to back of wall control. White wire end attaches to terminal #3 screw; black striped wire end attaches to terminal #4 screw.

Locate where top mounting screw will go. Mark location on wall. Drill 1/16" (1.5) pilot hole into wall. Fasten top screw into wall with screw head out from wall about 1/8" (3). Fasten wall control into top slot hole by pushing down firmly onto screw head. For drywall, concrete, etc., drill 3/16" (5) pilot hole for anchors. See Figure 18

Mark and drill 1/16"(1.5) pilot hole through bottom screw hole. Insert screw through bottom hole from the front, and tighten screw. Route wiring from behind through one of the recessed cutouts. Avoid pinching the wires.

CONNECTING WIRES:

Route wiring through cutout, along wall and ceiling, to opener power head chassis. Use provided staples to secure wiring. Do not pinch wiring.

Route wiring through wire guide of chassis to terminal area of control panel. See Figure 17

Remove about 1/2" (13) of insulation from the end of each wire. Insert white wire end firmly into terminal hole #3. Insert black striped wire end into terminal #4. To remove wiring, depress tab and pull out wiring. Multiple wall controls may be installed, parallel or series, if wires are properly connected to terminals 3 and 4 as explained.

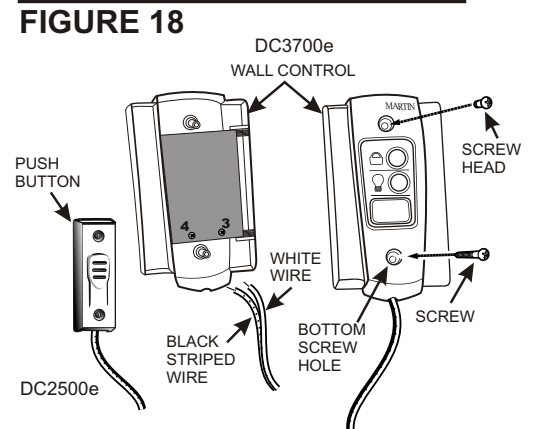
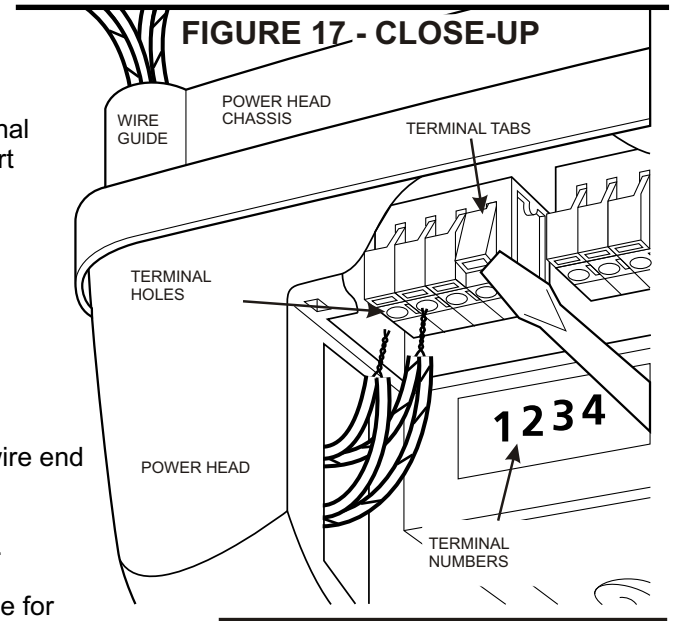
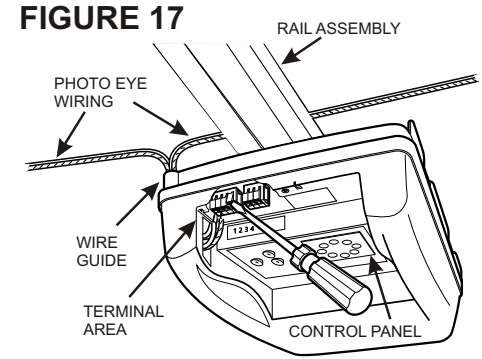

**STEP 9
FASTENING POWER ARMS**

Close the garage door by hand.

Remove tape from rail assembly holding straight power arm and allow it to hang freely. See Figure 19

Pull the emergency release cord to disconnect trolley (A red square dot will appear next to the underside red catch). Slide trolley to about 12" (305) from the opener header bracket. See Figure 20

Position straight power arm and curved power arm so at least two sets of holes line up.

Fasten arms together with 3/8" X 1" short neck carriage bolts and 3/8" lock nuts. Remove Temporary Tie. See Figures 19 and 20

Pull the emergency release cord to activate trolley (The red dot next to the underside red catch will disappear). Raise door by hand until trolley locks with belt or chain connector inside rail assembly. Pulling down on the emergency release cord with the attached knob connects or disconnects the trolley to the connector on the chain or belt. See Figure 21

Always close the door before releasing the trolley from the connector. The emergency release tag must be installed above the red knob and adjusted to about 6' (1830) above the floor. See Figure 20

Do Not Use the Emergency Release Cord And Knob To Pull Door Open Or Closed.

FIGURE 21

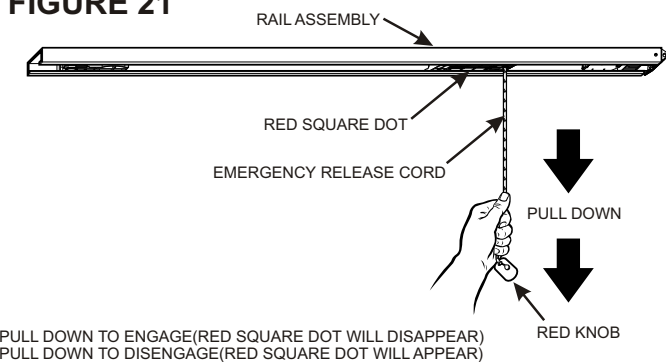

FIGURE 19

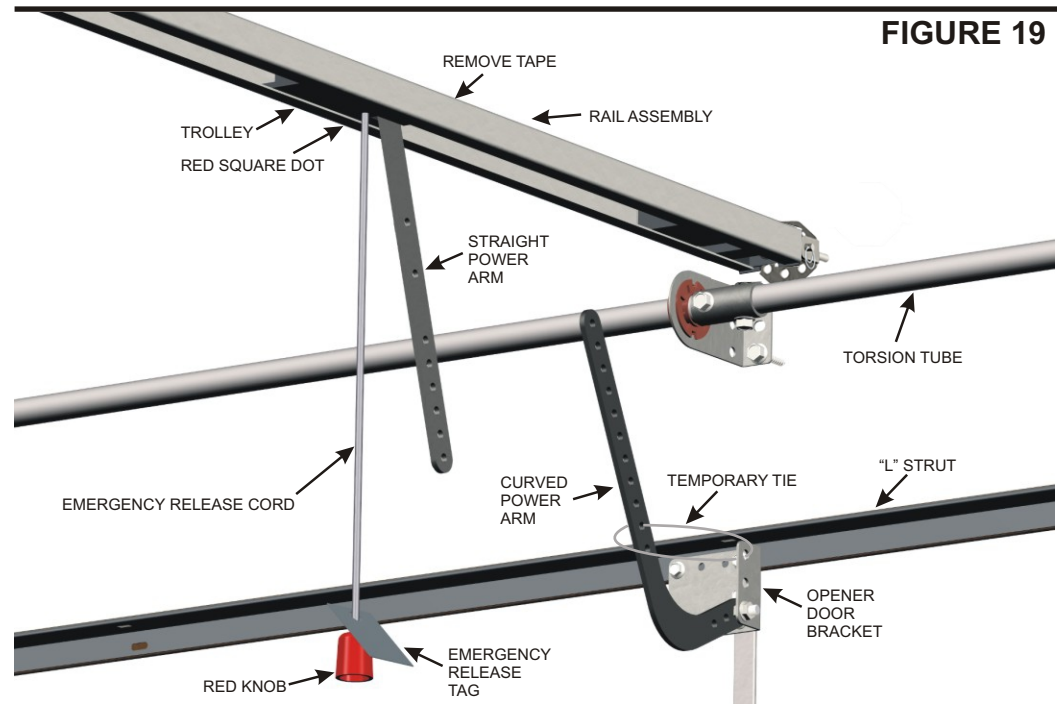
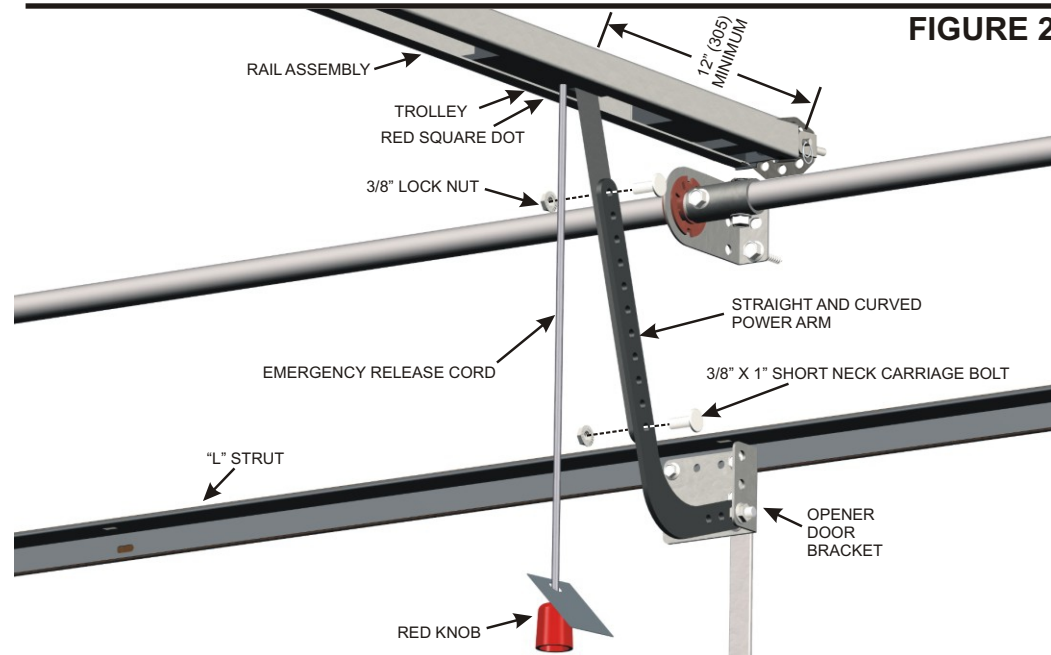

FIGURE 20



**STEP 10
CONNECT OPENER TO POWER**

CORD AND PLUG

To reduce the risk of electric shock, your opener is provided with an insulated power cord with a 3-prong grounding plug. The power cord permits easy connection to and disconnection from an electrical outlet. The power cord must be plugged-in to a standard grounded outlet. If there is no outlet available at the location, you must have a qualified electrician install an approved-grounded outlet at the proper location.

WARNING! To help prevent electrocution or fire, etc., the installation and wiring and outlet must be done in accordance with local electrical and building codes. DO NOT use an extension cord. DO NOT use a 3-prong to 2-prong plug adapter. DO NOT modify or cut off the grounding pin on the plug.

Plug the power cord into a properly grounded outlet. The #8 LED on the opener control panel will illuminate, showing that the power is on. See Figure 23

OPTIONAL PERMANENT WIRING: (If required by your local electrical code)

WARNING! Contact a qualified electrician to run the necessary wiring to your opener and to perform the electrical connections.

Disconnect the power at the circuit breaker.

Remove the Power Head Housing. Unsnap the power cord strain relief cover by disengaging the tabs. Cut the power cord within 6" (152) of the terminal block. Replace the strain relief cover by snapping tabs back into place. Knock out conduit hole, and bring in the permanent wiring and conduit. Secure conduit to chassis. Attach wiring using suitable wire nuts (not provided). Reinstall power head housing.

Connect power at the breaker. The #8 LED on the opener control panel will illuminate, showing that the power is on. See Figure 22

FIGURE 22 OPTIONAL PERMANENT WIRING

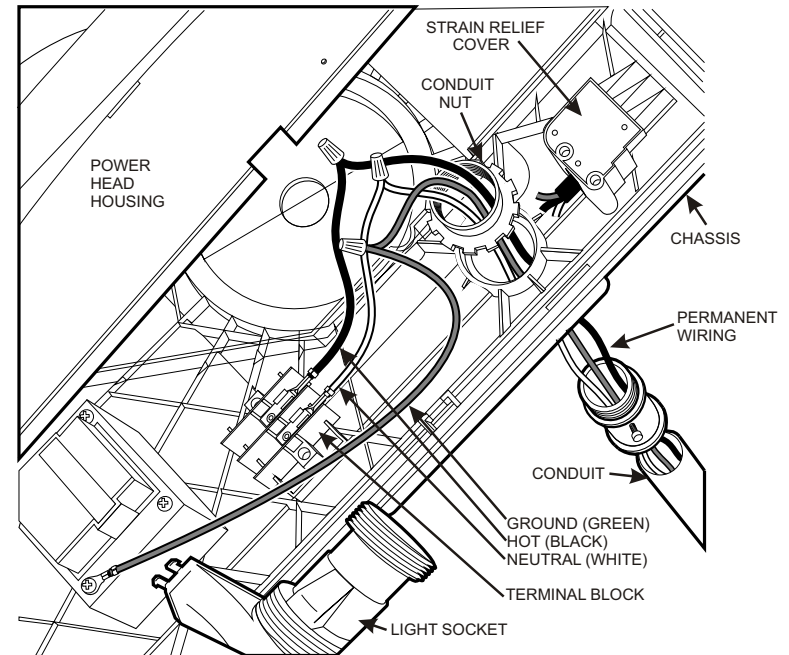
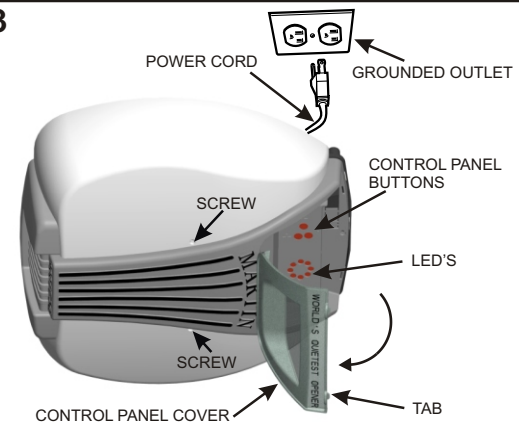

FIGURE 23



**STEP 11
MARTIN "SMART COMPUTER" CONTROL PANEL**

Open control panel cover by gently pulling on the 2 tabs. Do not twist cover or hinges may break. See Figure 23

The 3 Control Panel Buttons are labeled "P", "+", and "-". The circular display contains 4 numbered LED's. See Figure 24

NOTE: When setting the adjustments, face the garage door while looking up at the control panel.

The LED's show useful information regarding the opener's normal use as well as Troubleshooting. See Figure 24

FIGURE 24 MARTIN "SMART COMPUTER" CONTROL PANEL

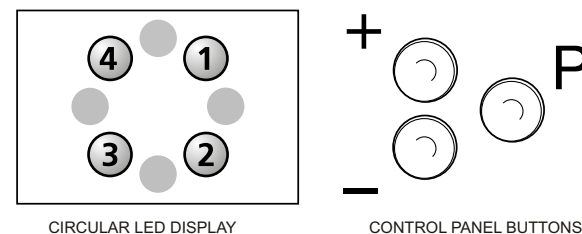

STEP 11 CONTINUED

SETTING THE ADJUSTMENTS

Before beginning, confirm that the garage door is the closed position, the trolley is connected to the chain or belt connector, and the #4 LED is illuminated showing that the power is on.

The adjustments made are Open Travel Limit, Close Travel Limit, the first Transmitter Programming, and if necessary the Opening Force and Closing Force.

REFER TO THE FOLLOWING TO PROGRAM OR CHANGE THE PROGRAM OF THE MARTIN "SMART COMPUTER":

TO PROGRAM

Press and hold the "P" button for about 5 seconds. When all LEDs illuminate release the button. See Figure 25

OPEN TRAVEL LIMIT

LED #1 should be blinking. Press and hold the "+" until the door is in the opened position. Release this button. If the door is not in the desired position, press the "+" button or the "-" button to move it slightly. Once the door is in the desired position, press and release the "P" button. See Figure 26

CLOSE TRAVEL LIMIT

LED #2 should be blinking. Press and hold the "-" button until the door is in the closed position. Release the button. If the door is not in desired position, press the "+" or the "-" button to move it slightly. Once the door is in the desired position, press and release the "P" button. See Figure 27

Attention! Do not close door tight on floor.

FIRST TRANSMITTER PROGRAMMING

LED #3 should be blinking. While LED #3 is blinking, press and hold the desired button on the transmitter. When the LED #3 blinks rapidly, release the transmitter button. The opener has now learned the particular code of this transmitter. Press and release the "P" button. This stores the code in memory. See Figure 28
For additional transmitter programming see Figures 39, 39A, 39B.

END PROGRAMMING After the LED fade out in a circular pattern the LED #4 should be illuminated. Press transmitter button to open and close the door two times. This allows the opener smart computer to set its complete memory and "learn" the proper operating levels. Each time the door is opened or closed the #3 LED illuminates about 1 second as the belt or chain tab activates the reference switch on the power head chassis. This is a visual check regarding computer memory retention. The "smart computer" retains memory even after a power outage. See Figure 29 next page.

NOTE: If one setting needs to be changed without adjusting any of the other settings, simply press and hold the "P" button for about 5 seconds, then press and release "P" repeatedly until the desired setting is reached. This bypasses the unneeded adjustments. When desired setting is complete, simply press "P" as many times as needed to return the opener to normal operating mode with LED #4 illuminated.

FIGURE 25

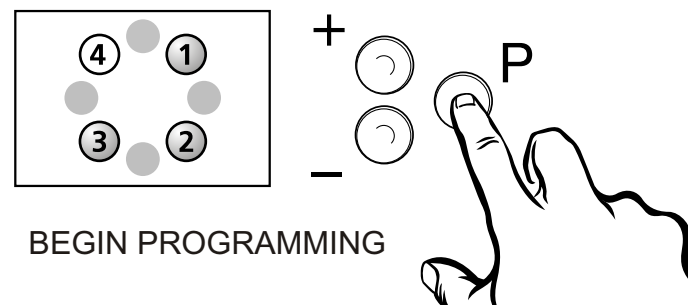

FIGURE 26

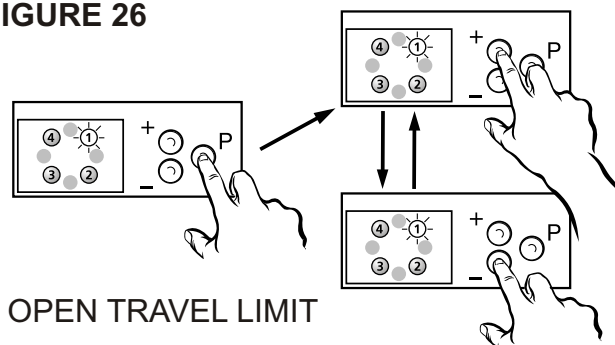

FIGURE 27

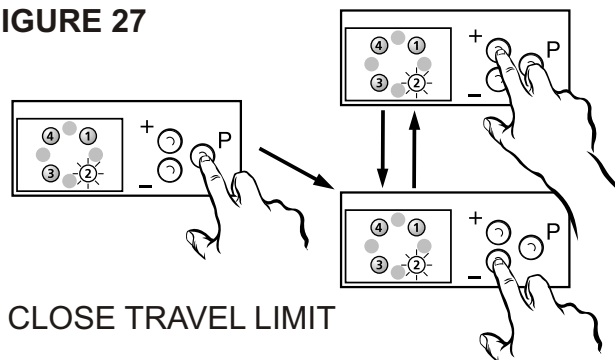
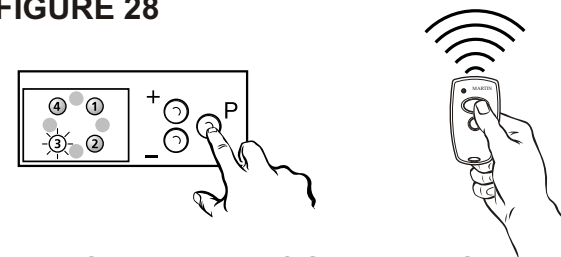

FIGURE 28



FORCE SETTING

Force settings are automatically set to the proper minimum level by the Martin "Smart computer", each time the door is opened and closed. If the force needs to be changed, press and hold the "P" button for about 20 seconds.

UP FORCE

LED #1 and #3 should be blinking. Press and release the "+" or "-" button once. The illuminated LEDs around the display will display the current force setting. By pressing the "+" or "-" key, the force can be increased (+) or decreased (-). The force should be set as low as possible. Once the desired force is selected, press and release the "P" button. See Figure 30

DOWN FORCE

LED #2 and #3 should be blinking. Press and release the "+" or "-" button once. The illuminated LEDs around the display will display the current force setting. By pressing the "+" or "-" key, the force can be increased (+) or decreased (-). The force should be set as low as possible. Once the desired force is selected, press and release the "P" button. See Figure 31

FIGURE 29

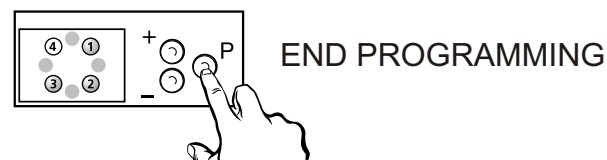
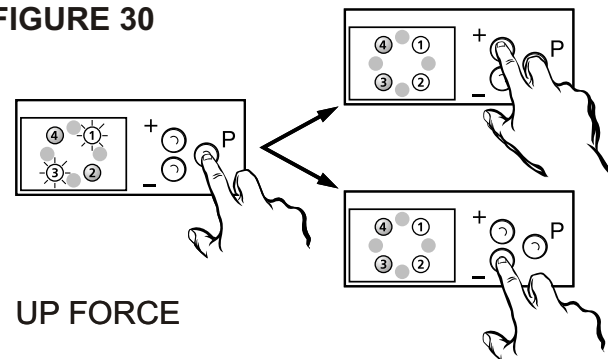
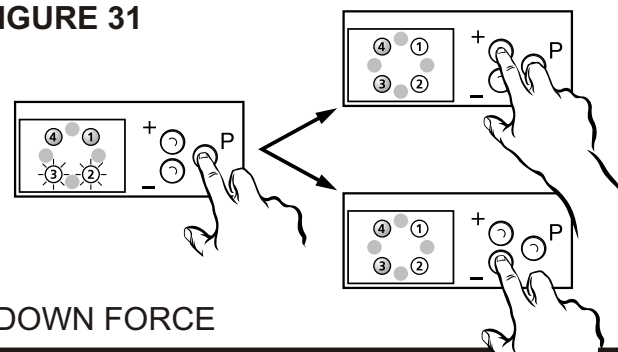

FIGURE 30



UP FORCE

FIGURE 31



DOWN FORCE

WARNING



TO REDUCE THE RISK OF SEVERE INJURY OR DEATH, READ AND FOLLOW ALL INSTRUCTIONS

IMPORTANT MAINTENANCE & SAFETY INSTRUCTIONS

- **Monthly**, check the opener's down cycle safety reverse. The door must reverse when it contacts a 1 1/2" (38) high object (or a 2X4 board laid flat) on the floor, in line with the door opener. A closing door must also reverse if the photo eyes are interrupted. See Steps 12,13.
- **Always** keep the moving door in sight and away from people and objects until it is completely closed. **NO ONE SHOULD CROSS THE PATH OF THE MOVING DOOR.**
- **NEVER** go under a stopped, partially open door.
- **Do not allow children** to operate or play with the garage door controls. Keep the remote control away from children.
- **If the Safety Reverse** or any other part of the garage door and opener system do not work properly, or if you do not understand, call a trained Martin Door Dealer.
- **The emergency release** should only be used when garage door is in the closed position. Weak or broken springs may cause door to fall, if released in the open position, increasing the risk of severe injury or death. Use caution when using the release with door open.
- **Monthly** visually check lift cables, spring assembly, hardware, etc. for wear and stability.
- **KEEP GARAGE DOOR PROPERLY BALANCED.** See garage door owner's manual. An improperly balanced door increases the risk of severe injury or death. Call a trained Martin Door Dealer to repair lift cables, spring assemblies and other hardware.

**STEP 12
TEST DOWN FORCE REVERSAL**

Place a 1 1/2"(38) high object (or a 2X4 laid flat) on the floor, in line with the door opener. When the closing door contacts the object, it should stop, reverse, and automatically return to the open position. If the door does not reverse, reset the down travel limit so that the door travels slightly further down in the closed direction. Then, retest the unit as described above. See Figure 32. Open and close door twice before beginning test.
NOTE: Rail assembly may require center support to ceiling.

WARNING! If the door does not reverse, disconnect your opener and call a trained Martin Door Dealer.

**STEP 13
TEST DOWN CYCLE PHOTO EYES REVERSAL**

Photo eyes must be clean and properly aligned. Loosen wing nuts to rotate photo eyes vertically or horizontally for correct alignment. See Figure 33.

The green light on the transmitter photo eye and the red light on the receiver photo eye must illuminate or the door will not close. See Figure 34

Start the door in the downward direction. Interrupt the invisible beam by waving a solid object between the photo eyes. The Door Must Reverse! See Figure 35

Faulty photo eyes can be bypassed with constant pressure on a wall control/push button or transmitter button.

NOTE: To test the Up Force, place an object to stop the door in its upward direction. The opener should stop when the door contacts the object. The Martin Opener also has a third reversal protection system, which automatically opens the door in 30 seconds if Opener Reversal System fails or if the door is unable to completely close in 30 seconds time.

**STEP 14
APPLY LABELS TO INSIDE OF GARAGE**

Martin Finger Shield™ Garage Door and Opener Systems include a maintenance and warning label on a packet fastened to the backside of the #3 door section. Inside the packet are the owner's garage door and opener instruction manuals. See Figure 32

Important safety and instruction labels are included with your opener package. These labels and the Instruction Manual must be fastened inside your garage where they can be easily seen by all. We recommend fastening them next to the wall control. To fasten labels, peel off the protective backing, and press onto smooth, clean surface. Tacks or additional adhesive may be necessary. DO NOT PAINT OVER ANY LABELS. See Figure 32

FIGURE 32

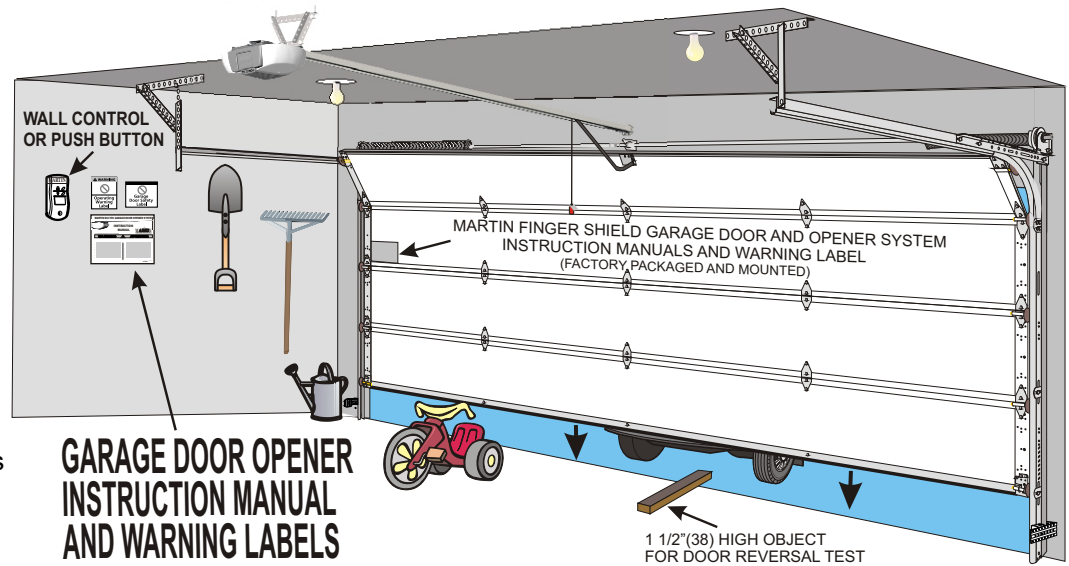

FIGURE 33

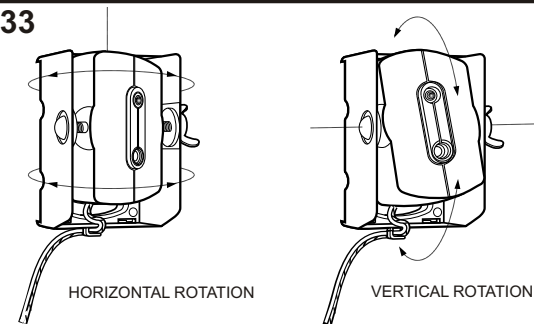

FIGURE 34

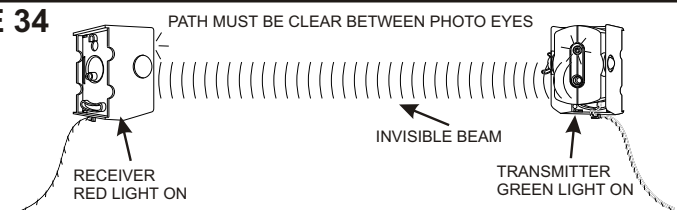
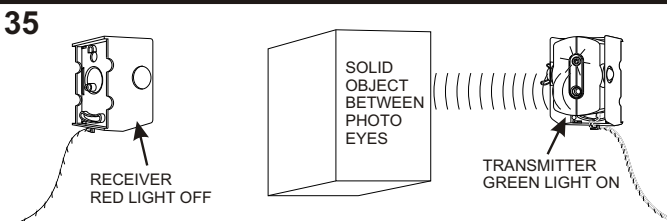

FIGURE 35



STEP 15 TRANSMITTERS

THE BATTERY:

Pry transmitter apart using a small coin to expose battery. The 3 Volt #CR2032 battery is shown. Battery life can last 4 to 5 years. See Figure 36.

TRANSMITTER MOUNTING CHOICES:

Transmitter can be carried alone, attached to a key chain, attached to the visor clip or attached using the optional mounting plate. See Figures 36, 37, 38.

MULTIPLE TRANSMITTERS:

Each transmitter has been factory programmed with different private security codes. For your information there are 284 trillion different codes. 2-channel transmitters have 2 different codes. 4-channel transmitters have 4 different codes. Additional transmitters that come with the opener or are purchased separately as accessories have their own different codes that must be changed to match your first transmitter.

Connect the programming tine to both transmitters. See Figures 38, 39, 39A and 39B.

Press and hold button on your present transmitter. Indicator light will blink. See Figure 39A. While still holding the 1st transmitter button, press and hold the button on the new or second transmitter. Code transfer will occur in approximately 2 seconds when the indicator light on the new transmitter illuminates continuously. See Figure 39B

The 315 mhz transmitters are "Home Link" compatible. Follow instructions furnished in the automobile owners manual for non-rolling code applications.

TRANSMITTER OPERATION:

Press button until garage door begins to move. The indicator light on the transmitter will be blinking. Press button at any time during travel to stop the garage door. See Figure 40

FIGURE 36



FIGURE 37

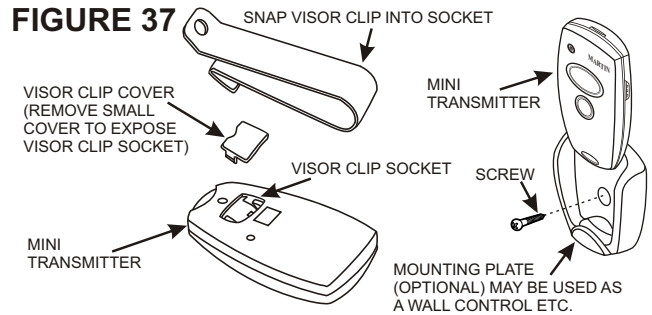

FIGURE 38

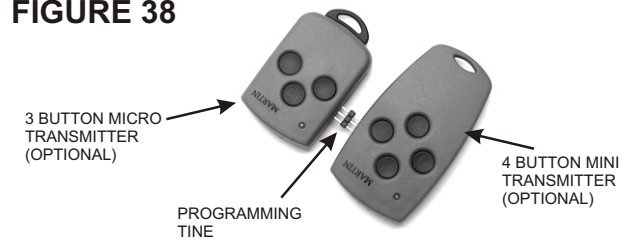

FIGURE 40

FIGURE 39

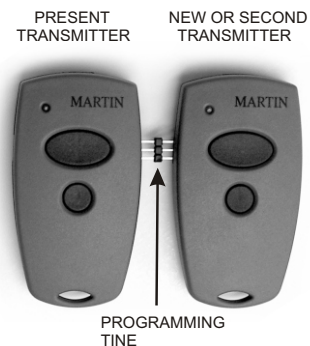

FIGURE 39A

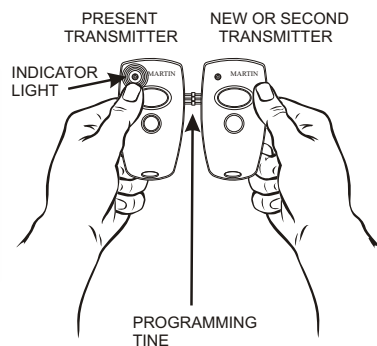
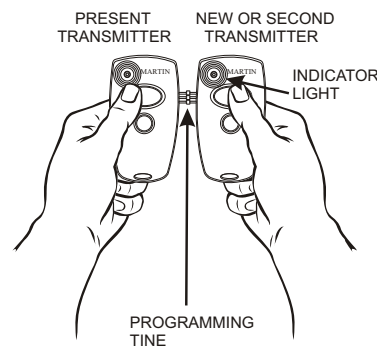

FIGURE 39B



FCC Certified: This device complies with Part 15 of the FCC rules. Operation is subject to the following two conditions: (1) this device may not cause harmful interference, and (2) this device must accept any interference received, including interference that may cause undesired operation. Changes or modifications not expressly approved by the party responsible for compliance could void the user's authority to operate the equipment.

STEP 15 CONTINUED

ANTENNA:

The optional 315 mhz receiver antenna wire on the back of the opener is about 13"(340) long and can have multiple arrangements for the best distance. In a "normal installation" the distance from the transmitter to the power head should be 50' (15000) to 150' (45000). **Do not lengthen or shorten the antenna.** See Figures 41, 42.

NOTE: The distance from the transmitter to the opener power head may be reduced by electrical interference in the area, spherical disturbances in the area, various lights or transformers in and out of the garage, automatic sprinkler system timers, various audible or inaudible sounds, noise, radio signals in the area, concrete, steel or lead in and around the garage, antenna wire touching any metal. If necessary, use plastic or string type ties to keep antenna wire away from punched angle, etc.

**STEP 16
WALL CONTROL/PUSH BUTTON OPERATION**

The wall control button will illuminate when the wires are properly connected as explained in Step 8.

Press wall control/push button until garage door begins to move. Press button at any time during travel to stop the garage door. See Figure 43.

The vacation lock-out feature on the wall control is used to lock out all remote control transmitters. The wall control button or keyless entry system can still activate the door. **Press** and hold vacation lock button for 2-3 seconds to activate lock-out. The wall control button will blink continuously while lock mode is active. To unlock, press and hold vacation lock button for 2-3 seconds. The wall control button will then return to normal illumination. See Figure 43

NOTE: The opener will accept multiple wall controls/push buttons if the wires are properly connected as explained in STEP 8.

OPENER LIGHTS OPERATION:

Lights will illuminate for about 4 minutes whenever opener is activated. Lights will blink if the opener senses an obstruction. To stop lights from blinking, remove obstruction and operate door normally.

Lights can be turned on and off by manually pushing light switch button on the wall control. Lights turned on manually can only be turned off by manually pushing light switch button or by opening and closing the door. See Figure 43.

FIGURE 41

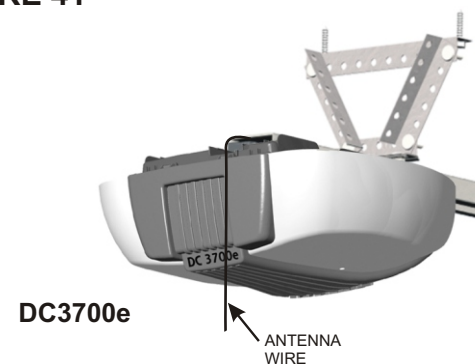

FIGURE 42

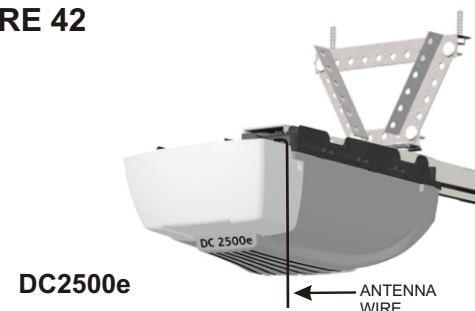
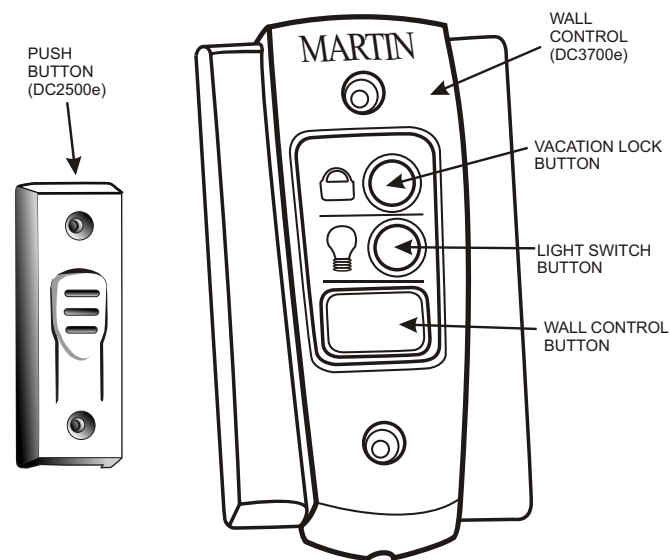

FIGURE 43



STEP 17

BELT OR CHAIN RAIL ASSEMBLY TENSION ADJUSTMENT

Your pre-assembled Belt or Chain Assembly comes from the factory with the tension adjusted to factory specifications. **There should be no need for adjustment.**

CHECKING TENSION:

Release trolley from belt or chain connector. The tension nut/washer should be spaced approximately 1/16" (1.5) from the stationary end-stop arch at the header end of the rail assembly. See Figure 45.

ADJUST THE TENSION:

Increase tension by tightening tension nut clockwise.

Decrease tension by loosening tension nut counterclockwise.

STEP 18

TO SHORTEN BELT OR CHAIN RAIL ASSEMBLY UP TO 24" (610): (See exploded view of rail assemblies on Page 21)

Note: For trained Martin Garage Door Dealers: Consult factory if cut-off is more than 24" (610) because the position tab must be kept in the proper location.

Loosen belt or chain tension as much as possible.

Remove screws from sprocket holder and rail end-stop.

Slide belt or chain and all rail assembly parts out of rail assembly from header end.

Measure and cut off excess rail assembly (1" (25) increments only) from header end.

Disassemble connector assembly to expose free ends of belt or chain.

Use the same measurement as the excess rail assembly length and cut the same amount off both free ends of the belt or chain.

Use rail assembly end-stop as a guide, mark and drill two 3/16" holes on rail assembly sides for rail assembly end-stop screws.

Fasten both ends of the belt ribs or the chain links to the connector assembly.

Slide all rail assembly parts into rail assembly from header end according to original assembly.

Tension the belt or chain following STEP 17.

FIGURE 44

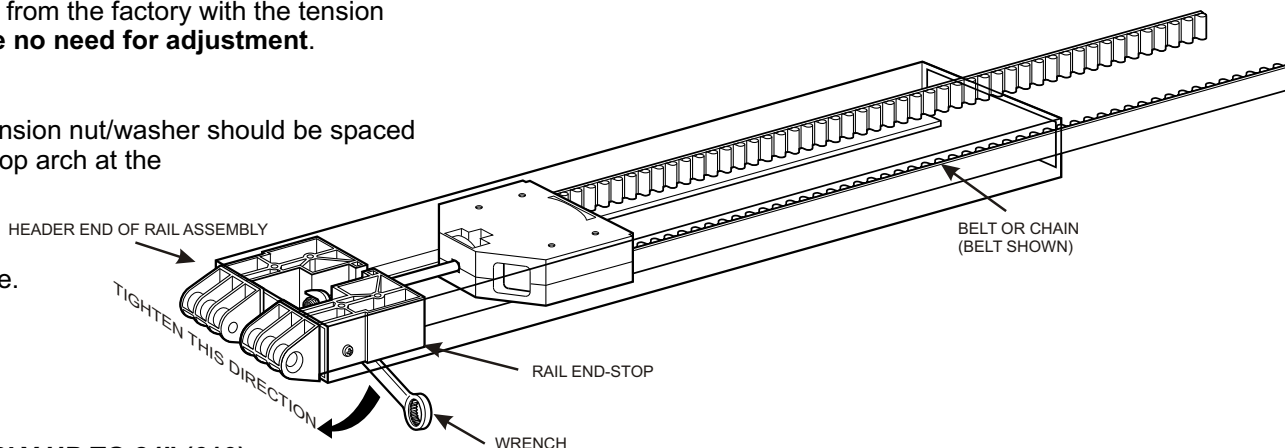
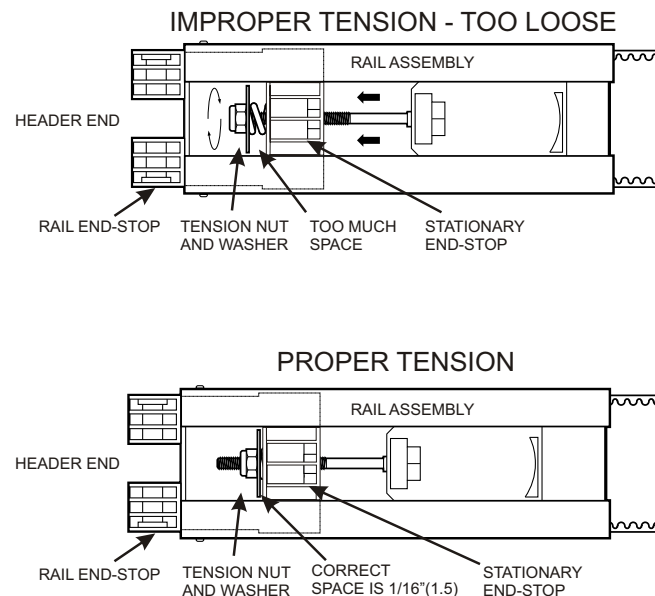
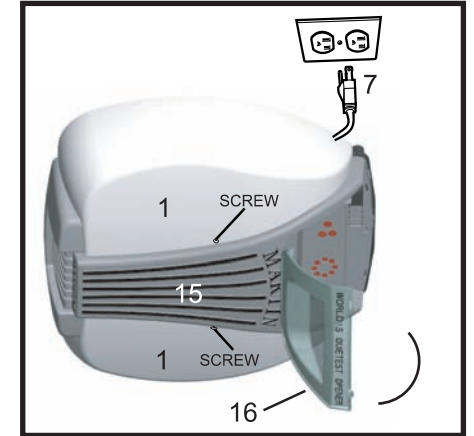
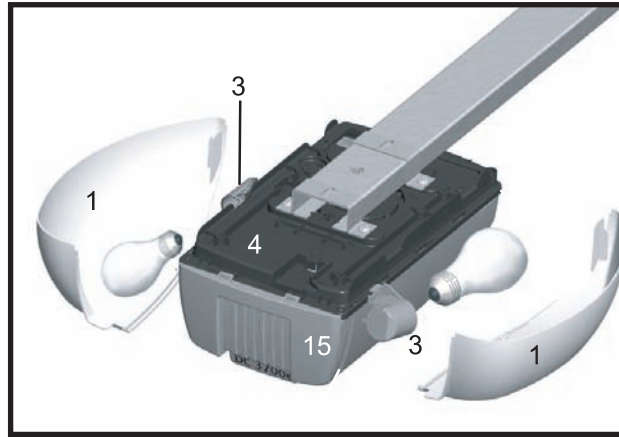
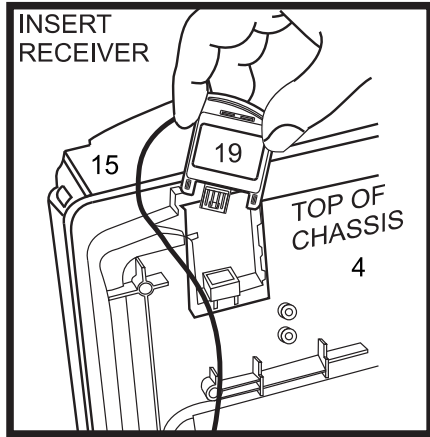

FIGURE 45 VIEW FROM BELOW



MARTIN DC 3700e POWER HEAD ASSEMBLY

- EXPLODED VIEW -



Item	Description
1.	Light Lens(2 lens for DC3700e, 1 lens at rear for DC2500e)
2.	Wire harness assembly
3.	Light socket w/ Wire Harness
4.	Chassis w/ Labels
5.	Connector
6.	Reference Switch
7.	Power Cord
8.	Strain Relief Cover
9.	Terminal Block
10.	Logic Board (LB)
11.	Wire Harness (TR to LB)
12.	Transformer w/ Screws (2)
13.	Motor Assembly complete with: Motor, Mounting Plate, RPM Sensor w/ Harness, RPM Wheel, Screws (4)
14.	RPM Sensor w/ Harness and Screw
15.	Housing w/ Screws & Labels
16.	Control Panel Cover w/ Label
17.	Varistor
18.	Motor Shaft Adapter (DC3700e only)
19.	Modular Receiver(315 mhz)

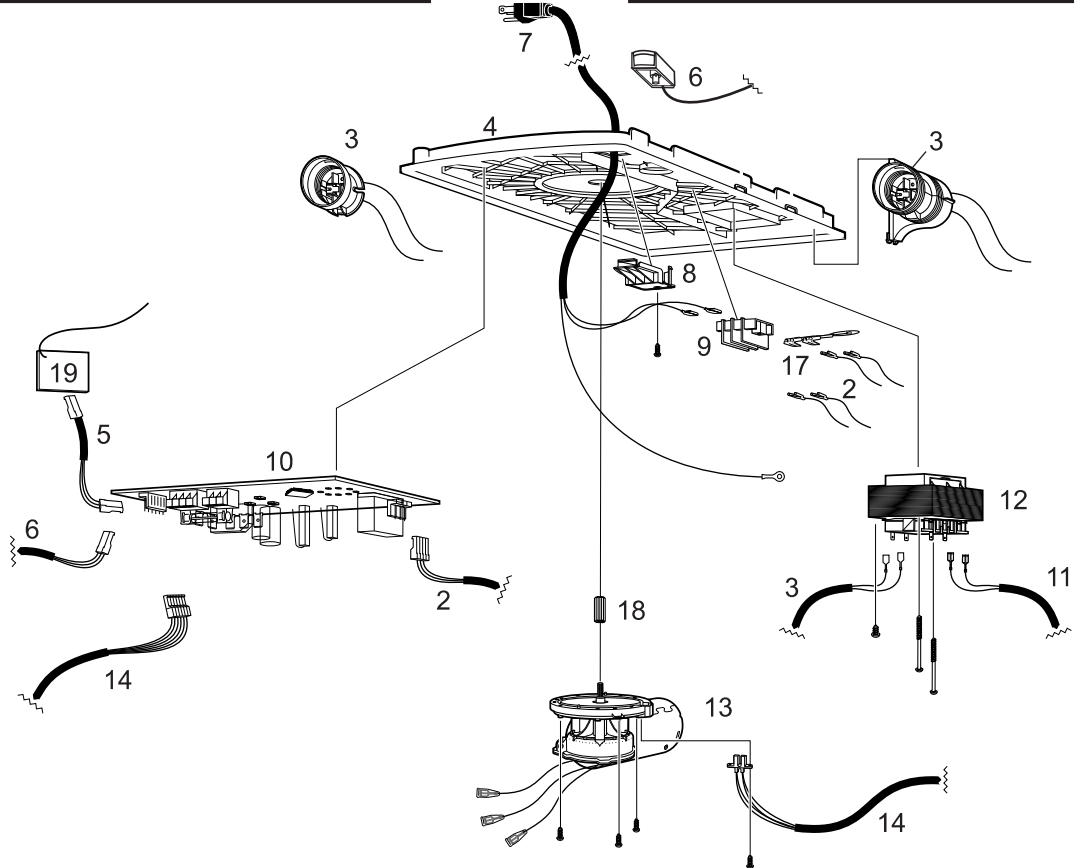

MARTIN DC 3700e BELT RAIL ASSEMBLY - EXPLODED VIEW -

Item	Description
1.	C-Rail
2.	Drive Sprocket
3.	Drive Sprocket Holder w/ Screws (2)
4.	Belt Guide
5.	Roller
6.	Roller Holder (2 piece)
7.	Rail End-Stop w/ Screws (2)
8.	Tension Bolt Assembly w/ Bolt, Spring, Washer, and Locknut
9.	Drive Belt w/ Position Tab
10.	Connector Assembly
11.	Trolley w/ Knob, Tag and Emergency Release Cord
12.	Straight Power Arm
13.	Emergency Release Tag and Knob
14.	Gray Motor Shaft Adaptor

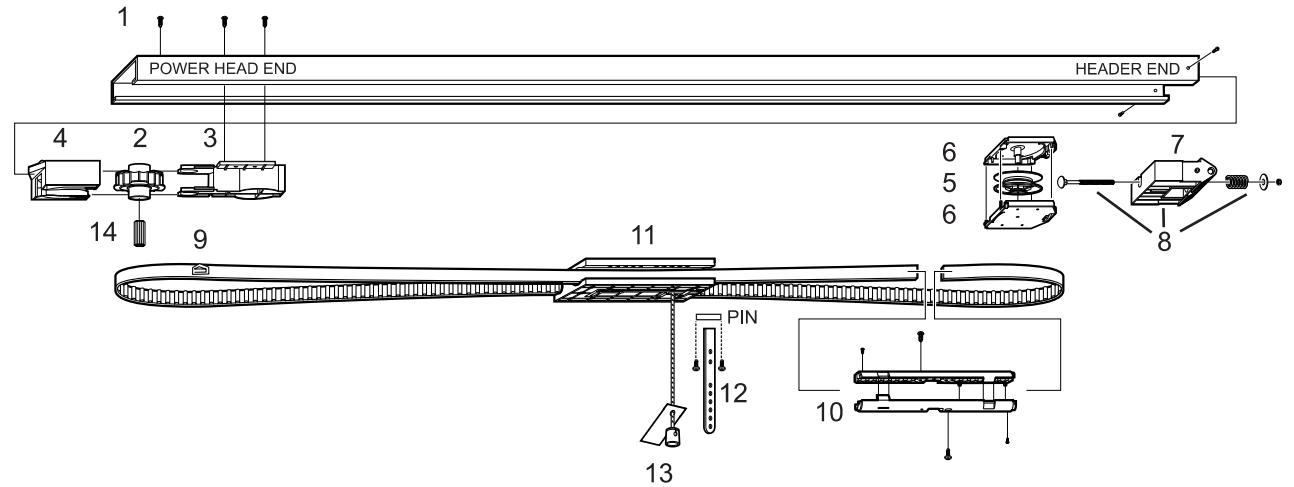

MARTIN DC 2500e CHAIN RAIL ASSEMBLY - EXPLODED VIEW -

Item	Description
1.	C-Rail
2.	Drive Sprocket
3.	Drive Sprocket Holder w/ Screws (2)
4.	N/A
5.	Roller
6.	Roller Holder (2 piece)
7.	Rail End-Stop w/ Screws (2)
8.	Tension Bolt Assembly w/ Bolt, Spring, Washer, and Locknut
9.	Drive Chain w/ Position Tab
10.	Connector Assembly
11.	Trolley w/ Knob, Tag and Emergency Release Cord
12.	Straight Power Arm
13.	Emergency Release Tag and Knob

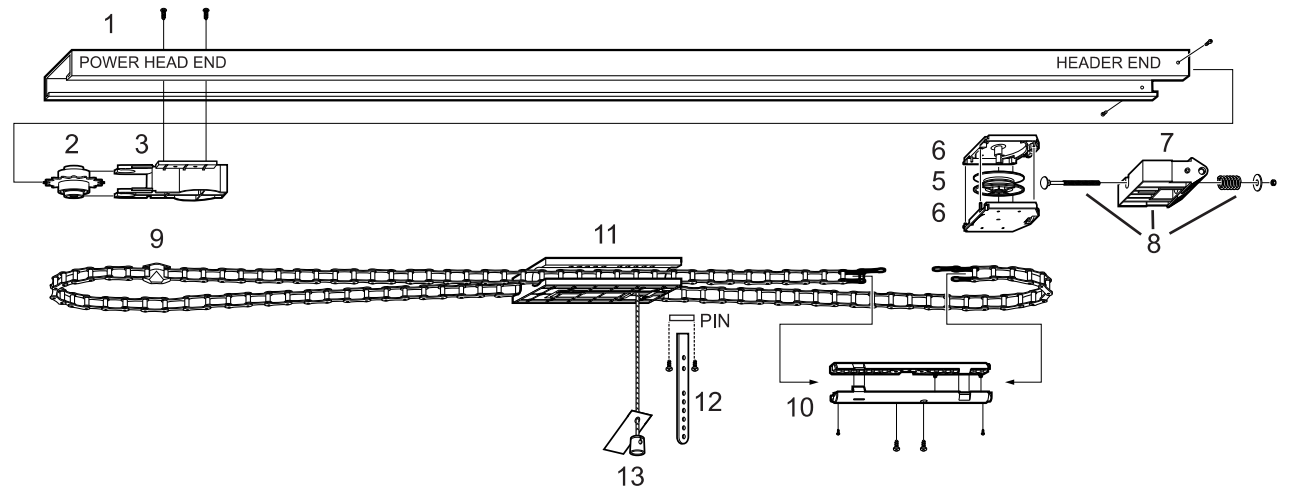

HAVING A PROBLEM?

Situation:	Likely Cause and Solution
Opener does not operate from either the wall control/push button or transmitter:	<p>Does opener have electricity? Plug a lamp into the electric outlet. If it does not turn on, have a profession service the electric outlet.</p> <p>Have you disengaged all locks on door? If not, do so.</p> <p>Has snow or ice built up under door? Door may be frozen to ground. Remove any restrictions.</p> <p>The garage door spring may be broken. Call a trained Martin Door Dealer.</p>
Opener operates from transmitter but not from wall control/push button:	<p>Are wiring connections correct? Check wall control wiring. See STEP 8.</p> <p>Is wall control button lighted? If not, disconnect wires to wall control and momentarily touch together. If opener runs, replace wall control. If opener does not run, check wiring connections at opener and check wires for shorts or breaks under staples.</p>
Opener operates from wall control/push button but not the transmitter:	<p>Is the wall control button light blinking? If so, your opener is in the vacation / lock mode. Push vacation lock button to turn off.</p> <p>Has the opener learned the code of the transmitter? Repeat transmitter programming steps. See STEP 15.</p> <p>Have all transmitters been set with the same code? Repeat code learning procedure. See STEP 15.</p> <p>Does the transmitter indicator light blink when the transmitter button is pressed? If not, replace battery.</p> <p>Are photo eyes obstructed? If so, door will only close while wall control/push button is pressed and held.</p>
Door does not open completely:	<p>Is something obstructing the door? Remove obstructions only after ensuring door area is free of persons, pets, and any other objects.</p> <p>If door has been working properly but now doesn't, increase the up force and/or reset the open travel limit. After adjustment Is completed, repeat the reversal tests. See STEP 12.</p>
Door does not close completely:	<p>Is something obstructing the door or in the path of the photo eyes? Remove obstructions only after ensuring door area is free of persons, pets, and any other objects. Rail assembly may require a center support to ceiling.</p> <p>If door has been working properly but now doesn't, increase the down force and/or reset the close travel limit. After adjustment Is completed, repeat the reversal tests. See STEP 13.</p>
Door opens but will not close at all:	<p>Check the photo eyes for proper connection and alignment. Clean the photo eyes.</p> <p>Increase force in down direction. After adjustment is completed, repeat The reversal tests. See STEP 12.</p>
Door reverses for no apparent reason:	<p>Is something obstructing the door? Clear ice, snow, sand or dirt from garage floor area where garage door closes. Also, pull emergency release knob with door in closed position. Open door manually. If it is unbalanced or a broken spring, call a trained Martin Door Dealer.</p> <p>Review and increase force adjustment setting for down travel. If door reverses from fully closed position, decrease travel limits.</p> <p>After adjustment Is completed, repeat the reversal tests. See STEP 12.</p>
Opener lights do not illuminate:	<p>Replace the light bulb(s)maximum 60 watts each. Use a standard size garage door opener bulb if regular type bulb burns out prematurely.</p>
Opener light does not turn off:	<p>Is the wall control light switch on? Press light switch button to turn off.</p>
Opener strains or maximum force is needed to operate door:	<p>Door may be out of balance or springs are broken. Close the door and use emergency release cord to disconnect trolley. Open and close door manually. A properly balanced door will hold itself halfway open while being supported entirely by its springs. If it does not, leave trolley disconnected and call a trained Martin Door Dealer. DO NOT increase the force to the opener to compensate for unbalanced or damaged door.</p>
Opener does not move door at all:	<p>Springs are broken or door is out of balance. Call a trained Martin Door Dealer.</p> <p>Door may be locked with a manual door lock. Disable or remove any manual door locks.</p>
Opener won't work due to power failure:	<p>Use the emergency release cord to disconnect trolley. Door can be opened and closed manually. When power is restored, reconnect trolley and resume automatic operation of door. See STEP 10</p>

USEFUL LED STATUS INFORMATION

1

Illuminates when door is in fully opened position.

2

Illuminates when door is in fully closed position.

3

Illuminates when opener is receiving signal from wall control button.
Blinks rapidly when opener is receiving a signal from transmitter or keyless entry.
Blinks slowly after activating vacation lock on wall control button
Illuminates for 2 seconds each time the position tab activates the reference switch as the door opens or closes.
Blinks when an obstruction is detected, door reverses, or other problem occurs.

4

Illuminates when power is on.

TROUBLESHOOTING - FOR TRAINED MARTIN GARAGE DOOR SERVICE TECHNICIANS

LED DISPLAY AFTER PRESSING "P"	CODE	PROBLEM	SOLUTION
# 1 Blinking	1	Adjustments setting interrupted before completion	Door can be operated normally. Recheck adjustments if adjustment settings were not completed. See STEP 11.
# 2 Blinking	2	Defective Reference Switch.	Have opener serviced. Replace reference Switch.
# 3 Blinking	3	Photo eyes became obstructed during downward door travel	Remove obstruction from path of door. Clean photo eyes or realign photo eyes. See STEP 13
# 4 Blinking	4	Defective RPM sensor.	Replace RPM sensor
# 1, # 4 Blinking	5	Force required to move door exceeded set force level	Check door for obstructions, proper manual operation, proper balance, or broken springs. Clear obstructions. If door is OK, increase force setting. After adjustment is made, repeat reversal test. See STEP 11.
# 3, # 4 Blinking	7	Opener exceeded maximum run time limit (45 seconds) for safety reverse Photo eyes not connected properly Photo eyes are dirty. Photo eyes not aligned. Other photo eyes fault.	Make sure rail assembly is connected to power head and belt or chain is moving. Check photo eyes wiring and connections. See STEP 7. Clean photo eyes. Realign photo eyes. Replace photo eyes.
# 1, # 3, # 4 Blinking	8	Force watchdog circuit found error Power limit (RTS) sensitivity exceeded. Self-Learned force limit exceeded	Check door for obstructions, proper manual operation, proper balance, or broken springs. Clear obstructions. Readjust force and run opener up and down twice. After adjustment is made, repeat reversal test. See STEP 12.
# 1,#2, # 3, # 4 Blinking	10	Internal control error	Replace defective parts.

WARNING



ATTENTION

If your door is "HIGH RISK", correct all areas listed below or replace it with a "Low Risk" Martin Finger Shield Garage Door.

IF UNSURE, CALL A TRAINED MARTIN DOOR DEALER

COMMON HIGH RISK GARAGE DOOR AREAS

COMMON REPORTED SERIOUS INJURIES

- Exposed wide-open section joints, inside and outside Hands & fingers entrapped, severed or crushed. 1/3 are Children.
- Exposed holes in tracks larger than 1/4" (7) Fingers entrapped or severed. Most are Children
- Exposed track brackets fastening vertical tracks to jambs Hands & arms entrapped, broken or severed. Most are Children.
- Exposed outside lift cables Entrapment or strangulation. Most are Children.
- Exposed rollers moving in vertical tracks with sharp leading edges. Fingers entrapped, cut or severed. Most are Children.
- Exposed center mount torsion springs bracket or side mount stretch springs .. Severing of body parts and death.
- Exposed one-piece door scissor arms with side mount stretch springs Body parts entrapped, broken or severed.

SECTIONAL DOORS

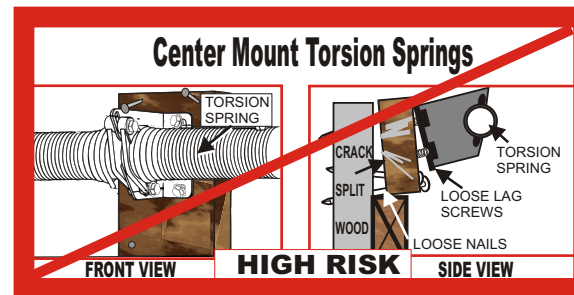
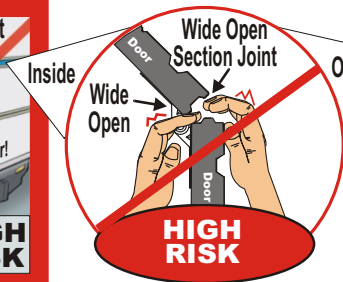

ONE PIECE DOORS

