



1. Contents

1.	Contents	2
2.	Information in this document	2
3.	General safety instructions	3
4.	Product overview	4
5.	Initial operation	6
6.	Initialisation	15
7.	Setting the end positions	16
8.	Programming	18
9.	Navigator (LCD monitor only)	20
10.	Overview of functions	22
11.	Error messages and rectification	37
12.	Technical data	40
13.	Maintenance	42
14.	EC Declaration of conformity	43
15.	Appendix	44

2. Information in this document

Original operating instructions

- Copyright.
- No part of these instructions may be reproduced without our prior approval.
- Subject to alterations in the interest of technical progress.
- All dimensions given in mm.
- The diagrams in this manual are not to scale.

Key to symbols

DANGER!

Indicates a hazard with a high level of risk which, if not avoided, will result in death or serious injury.

WARNING!

Indicates a hazard with a medium level of risk which, if not avoided, could result in death or serious injury.

CAUTION!

Indicates a hazard with a low level of risk which, if not avoided, could result in minor or moderate injury.

ATTENTION!

Indicates an imminent danger of damage or destruction.

CHECK

Indicates a check to be performed.

REFERENCE

Reference to separate documents which must be complied with.

 Action request

- List, itemisation

→ Reference to other sections of this document

DANGER!

Failure to comply with the documentation could result in life-threatening danger!

 Be sure to follow all the safety instructions in this document.

Warranty

The function and safety of the equipment is only guaranteed if the warning and safety instructions included in these operating instructions are adhered to.

Marantec GmbH + Co. KG is not liable for personal injury or damage to property if these occur as a result of the warnings and safety advice being disregarded.

Marantec does not accept any liability or warranty for damage due to the use of non-approved spare parts and accessories.

Use for the intended purpose

The CS 310 control is intended exclusively for the purpose of controlling door systems operated using mechanical limit switches or an electronic end position system (AWG absolute value encoder).

Target group

Only qualified and trained electricians may connect, programme and service the control.

Qualified and trained electricians must meet the following requirements:

- knowledge of the general and specific safety and accident prevention regulations.
- knowledge of the relevant electrical regulations,
- training in the use and care of appropriate safety equipment.
- capable of recognising the dangers associated with electricity.

Instructions regarding installation and connection

- The control is designed with X type terminals.
- The system must be disconnected from the electricity supply before carrying out any electrical work. It must be ensured that the electricity supply remains disconnected for the duration of the work.
- Local protective regulations must be complied with.
- Consult the manufacturer before carrying out modifications or replacing the mains connection cable.

Information concerning operation

- Unauthorised persons (particularly children) should not be allowed to play with permanently installed adjusting or control devices.
- Keep remote controls beyond the reach of children.

Regulations and bases for testing

For connecting, programming and servicing, the following regulations must be observed (the list is not exhaustive).

Construction product standards

- EN 13241-1 (Products without fire resistance or smoke control characteristics)
- EN 12445 (Safety in use of power operated doors - Test methods)
- EN 12453 (Safety in use of power operated doors - Requirements)
- EN 12978 (Safety devices for power operated doors and gates - Requirements and test methods)

EMC

- EN 55014-1 (Radio disturbance, household appliances)
- EN 61000-3-2 (Disturbances in supply systems - harmonic currents)
- EN 61000-3-3 (Disturbances in supply systems - voltage fluctuations)
- DIN EN 61000-6-2 (Electromagnetic compatibility (EMC) - Part 6-2: Generic standards – Immunity for industrial environments)
- DIN EN 61000-6-3 (Electromagnetic compatibility (EMC) - Part 6-3: Generic standards – Emission standard for residential, commercial and light-industrial environments)

Machinery Directive

- EN 60204-1 (Safety of machinery, electrical equipment of machines; Part 1: General requirements)
- EN ISO 12100 (Safety of machinery – general principles for design - risk assessment and risk reduction)
- EN 13849-1 (Safety of machinery – Safety-related parts of control systems – Part 1: General principles for design)

General safety instructions

Low voltage

- DIN EN 60335-1 (Household and similar electrical appliances - Safety - Part 1: General requirements)
- DIN EN 60335-2-103 (Household and similar electrical appliances - Safety - Part 2-103: Particular requirements for drives for gates, doors and windows)

Committee for Workplaces (Ausschuss für Arbeitsstätten - ASTA)

- ASR A1.7 (Technical Regulations for workplaces - Doors and gates)

4. Product overview

4.1 Versions

The following package options are available for the CS 310 control:

- CS 310 control with LCD monitor
- CS 310 control with LCD monitor in housing
- CS 310 control without LCD monitor (monitor is required for all settings except the end position setting)

All the above versions can be fitted with a plug-in weekly timer, a plug-in radio receiver and a plug-in transmission system (for a closing edge safety device and/or a safety element).

The following options are available for the housing:

- Housing unit with 3-button input unit CS
- Housing with ON/OFF key switch
- Housing with main switch
- Housing with Emergency Stop switch

The operating instructions describe the connection and programming options for the various versions:

- CS 310 control with LCD monitor connected and software version 1.54 or later

4.2 Motherboard CS 310 (with plugged-in LCD monitor)

Key:

- X1: Terminal block for mains connection
 X2: Terminal block for motor
 X3: Terminal block for command devices
 X4: Terminal block for safety elements
 X5: Terminal block for relay
 X6: Sockets for internal ON-OFF switch
 X7: Sockets for internal 3-button input unit
 X8: Sockets for LCD monitor
 X9: Sockets for radio receiver
 X10: Sockets for weekly timer
 X11: Sockets for digital end position system
 X12: Sockets for external radio receiver
 X13: Sockets for CS three-button input unit
 X14: Interface RS 485
 - Connection for CSI button input
 - Connection for RS 485 display
 X15: Terminal block for mechanical end position system
 X16: Sockets for BUS system (MS BUS)
 X17: Sockets for BUS system (MS BUS)
 X18: Frequency converter interface
 X19: Power supply for external devices
 230V / 50 Hz protected by F1 (1 A delay) fuse
 X20: Sockets for transmission system
 H4: operational readiness
 Lights up when power supply available.
 H6: Status message
 Lights up when the safety devices are actuated or if an error occurs
- S1: Programming button (+)
 (under the LCD monitor)
 S2: Programming button (-)
 (under the LCD monitor)
 S3: Programming button (P)
 (under the LCD monitor)

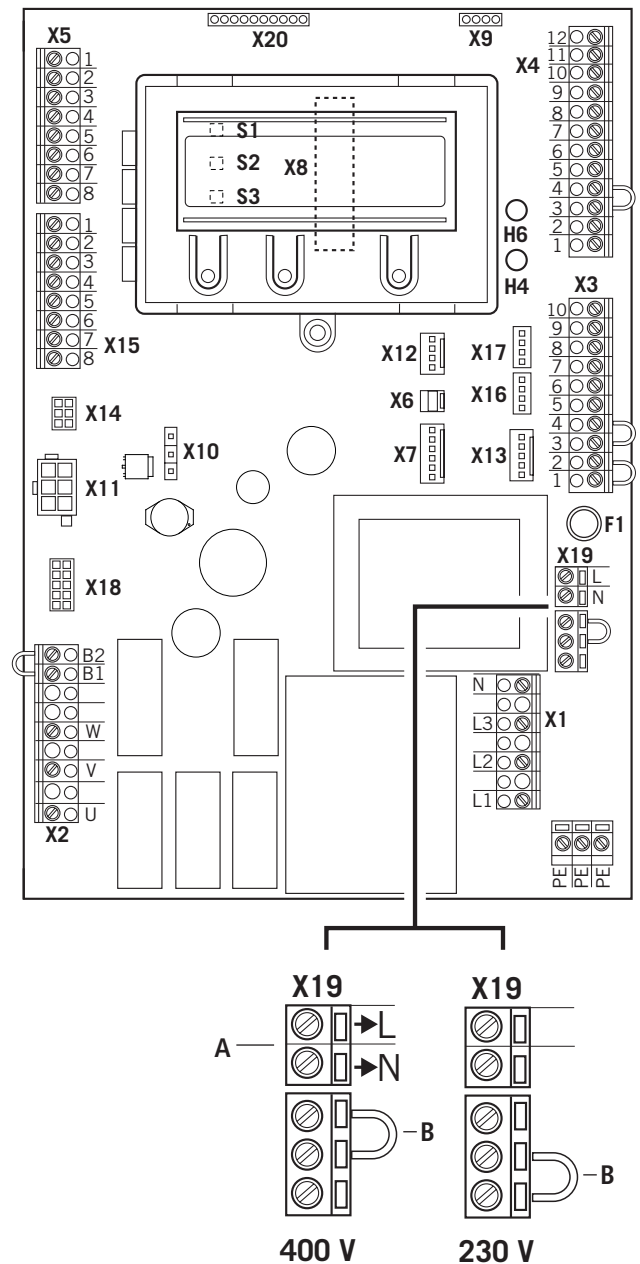

- A Output: 230 V.
 Power supply for external devices.
 No power line entry for the control unit itself.
- "5.3 Power supply for external devices
 (only for 400 V / 3-phase connection)"
- B The position of the jumper must take into account the power supply voltage and the motor voltage.

5. Initial operation

5.1 General

To guarantee that the equipment functions properly, it must be ensured that:

- The door is installed and operational.
- The Marantec operator motor is installed and ready for operation.
- The command and safety devices are installed and ready for operation.
- The control housing with the CS 310 control is installed.

i REFERENCE

The relevant manufacturers' instructions must be adhered to for the installation of the door, the Marantec motor, and the command and safety devices.

5.2 Mains connection

Preconditions

To guarantee that the controls function properly, the following points must be ensured:

- The mains voltage must correspond to the voltage stated on the type plate.
- The mains voltage must be the same as the voltage of the operator.
- For three-phase current, a clockwise rotating field is required.
- For a permanent connection, an all-pole main switch must be used.
- For a three-phase connection, only 3-way automatic circuit breakers (10 A) may be used.

! ATTENTION!

Malfunctions can occur as a result of incorrect installation of the control!

Before switching on the control for the first time, a check must be carried out after completing the wiring to ensure that all the motor connections at the motor and at the control is securely fixed. All control voltage inputs are galvanically isolated from the supply.

Detailed circuit diagram for mains connection and motor connection (400 V / three phase)

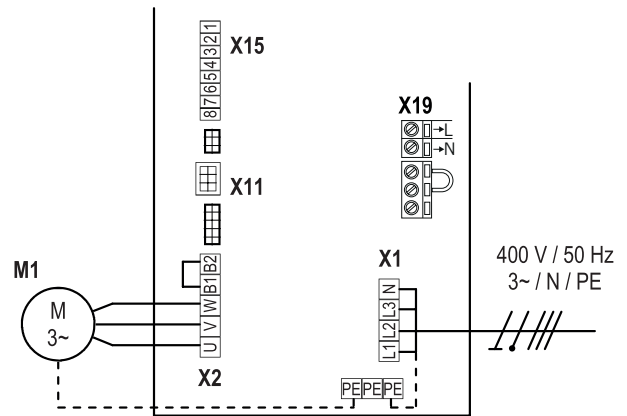

Detailed circuit diagram for mains connection and motor connection (230 V / three phase)

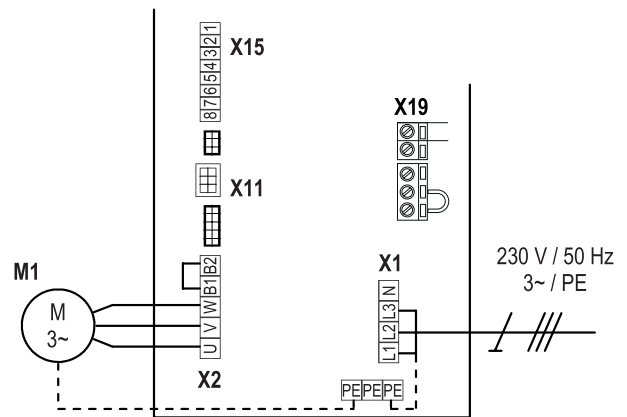

Detailed circuit diagram for mains connection and motor connection (230 V / single phase)

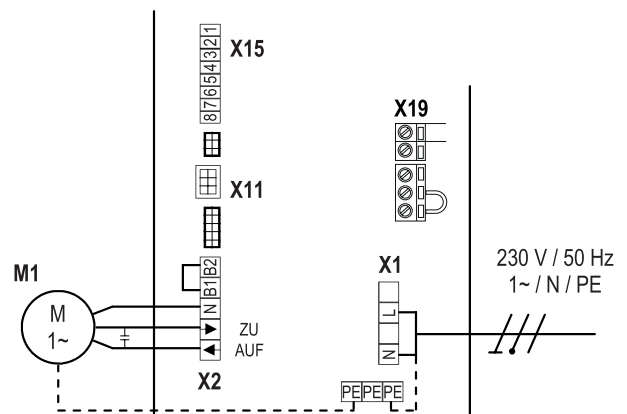

Key:

- M1: Motor
- X1: Terminal block for mains connection
- X2: Terminal block for motor
- X11: Sockets for digital end position system with safety circuit (SAFETY CIRC.)
- X15: Terminal block for mechanical limit switches (Safety circuit at X2 / B1-B2)
- X19: Power supply connection for external devices

Connection:

- ☞ Connect the digital end position system or mechanical limit switches to the control.
- ☞ Connect the control to the motor.
- ☞ Connect the control to the mains power supply.
- ☞ Cable groups must be secured close to their relevant terminals using a cable tie.

→ "12. Technical data" on page 44

5.3 Power supply for external devices (only for 400 V / 3-phase connection)

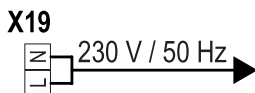

NOTICE:

The X19 connection can only be used with a 400 V / N / 3~ power supply.

Terminal X19 is protected with fuse block F1 (1 A-T).

5.4 Allocation of connections for absolute value encoder (sockets X11)

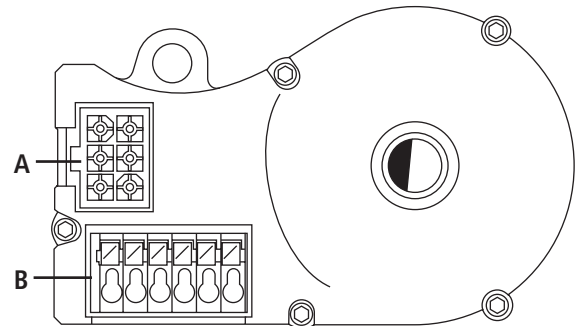

- A: AWG plugs
- B: AWG plug terminal

X11 sockets (at connection A)

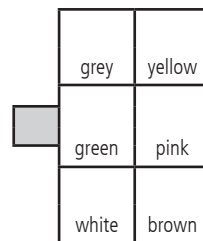

Depending on the operator, cables with either numbered or coloured wires are used for the AWG:

- 4 (grey): Safety circuit input
- 5 (green): RS 485 B
- 6 (white): GROUND
- 7 (yellow): RS485 A
- 8 (pink): Safety circuit output
- 9 (brown): 12V_{DC}

Sockets B (absolute value encoder only)

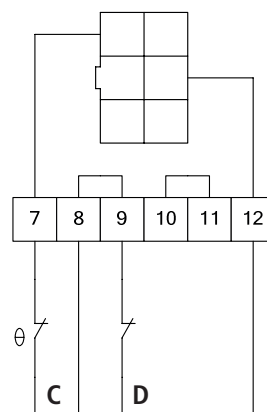

- C: Thermal element in door/ gate operator
- D: Emergency manual operation (emergency hand crank or emergency hand chain)

The end position system will be recognised automatically by the control during initial use. If a change is made at a later date, the relevant end position system must be selected via a parameter setting in INPUT mode.

Initial operation

5.5 Connection of mechanical limit switches (terminal blocks X15 and X2)

Terminal block X15

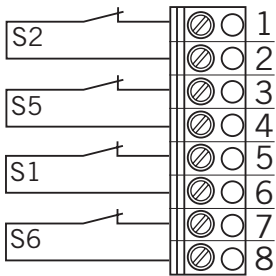

Terminal block X2

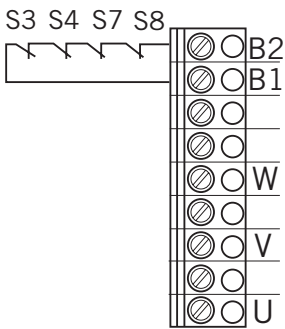

Connection example for solution with 6 leads

Terminal blocks X11 and X2

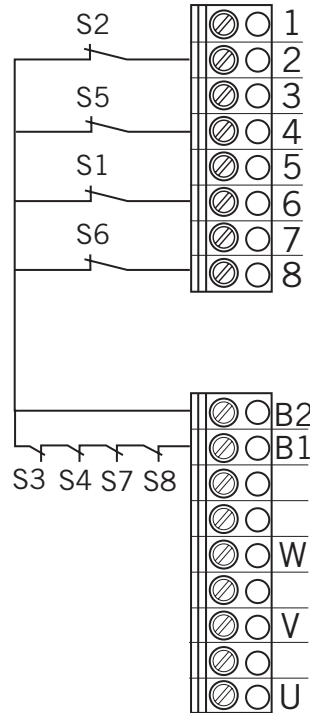

- S1 Additional limit switch, OPEN
- S2 Limit switch, OPEN
- S3 Safety limit switch, OPEN
- S4 Safety limit switch, CLOSED
- S5 Limit switch, CLOSED
- S6 Additional limit switch, CLOSED
- S7 Thermal overload protection for motor
- S8 Emergency operation (n.c. contact)

The end position system will be recognised automatically by the control during initial use and following a RESET. If a change is made at a later date, the relevant end position system must be selected via a parameter setting in INPUT mode.

→ "10.2 Input operating mode"

5.6 Connection of command devices

⚠ CAUTION!

Danger of injury due to uncontrolled movement of the door!

A CLOSE command for deadman mode without the door being in sight may be enabled only via Input 1 / MOD32 (X4 / 9–10).

☞ Install command devices for deadman operation in direct sight of the gate, but outside the danger area for the user.

If the command device is not a key switch:

- ☞ Install it at a height of at least 1.5 m off the ground.
- ☞ Install it so as to make it inaccessible to the general public.

Terminal block X3

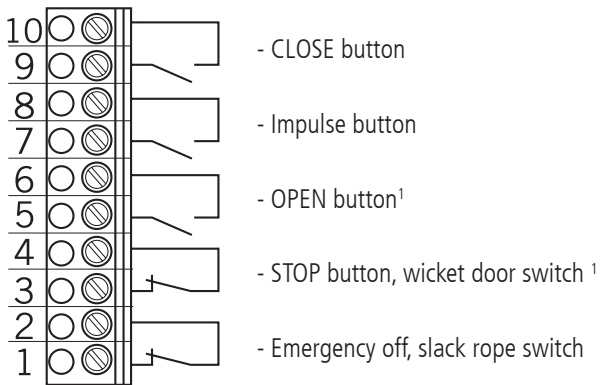

¹ Wicket door switch only possible as a contact with positive separation.

5.7 Connection examples for command devices (terminal block X3)

OPEN / STOP / CLOSE buttons

6-lead solution

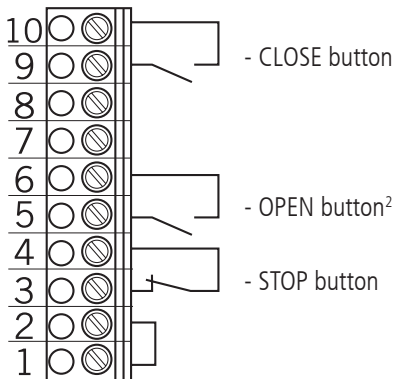

OPEN / STOP / CLOSE buttons

4-lead solution

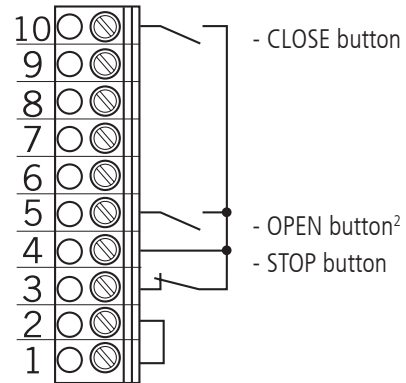

Key switch OPEN / CLOSE

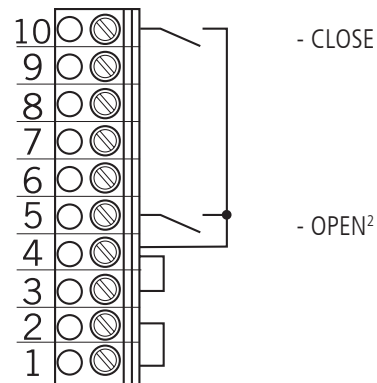

Impulse button

sequence control

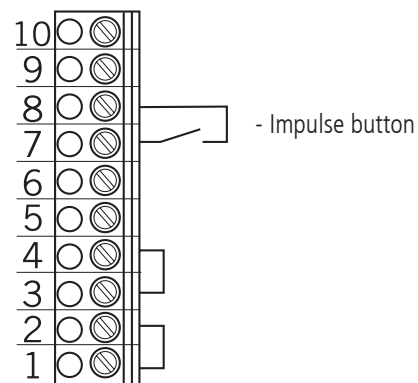

² If two-way traffic control is activated: OPEN button inside

Initial operation

5.8 Connection of closing edge safety device 1

The closing edge safety device will be recognised and programmed automatically during initial use and following a RESET. If a closing edge safety device is not connected, the input will be queried every time the power supply is switched on again, until a closing edge safety device is recognised. If a change is made at a later date, the relevant system must be selected via a parameter setting in INPUT mode.

→ "10.2 Input operating mode"

Terminal block X4

Opto-electronic closing edge safety device
 "SKS" parameter setting = MOD 1

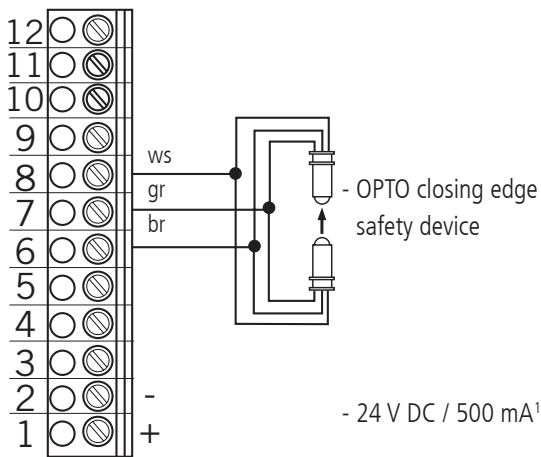

- ws: white
- gr: green
- br: brown

¹ for external switching devices
 (connection to terminals 1 and 2)

Terminal block X4

Electrical closing edge safety device (8.2 kΩ)
 "SKS" parameter setting = MOD 2

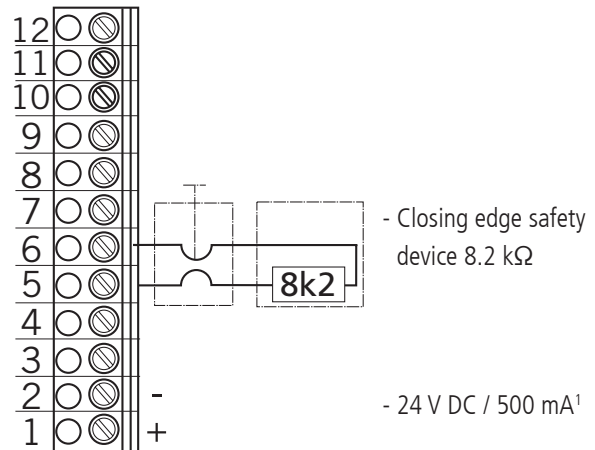

Terminal block X4

Pneumatic closing edge safety device (pressure sensor test)
 "SKS" parameter setting = MOD 3
 - Testing is activated automatically

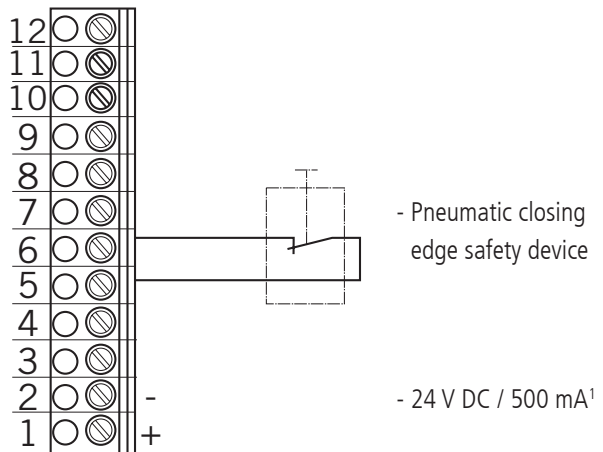

5.9 Photocell connection 1

The photocell system will be recognised and programmed automatically during initial operation and following a RESET. If a photocell system is not connected, the input will be queried every time the power supply is switched on again, until a closing edge safety device is recognised. If a change is made at a later date, the relevant system must be selected via a parameter setting in INPUT mode.

→ "10.2 Input operating mode"

Terminal block X4

Photocell NC

Parameter LIGHT BARR. 1 = MOD 2

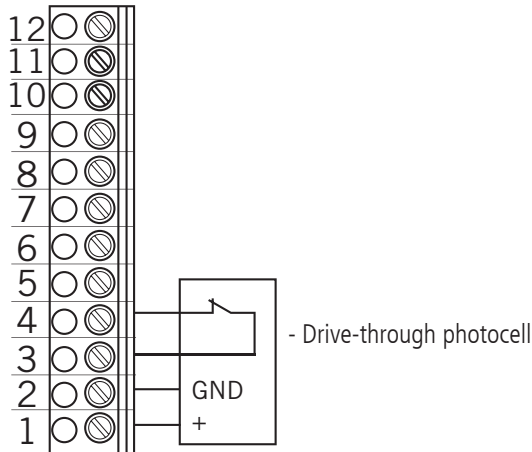

Terminal block X4

Marantec two-wire photocell

Parameter LIGHT BARR. 1 = MOD 1

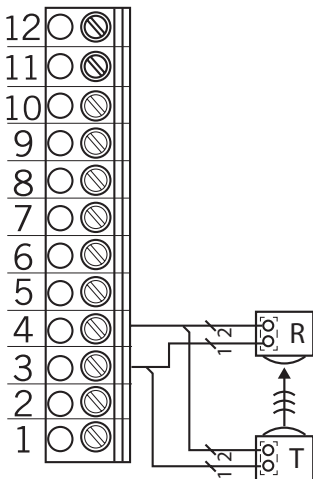

R: Receiver
T: Transmitter

Terminal block X4

Three-wire NPN photocell

Parameter LIGHT BARR. 1 = MOD 2

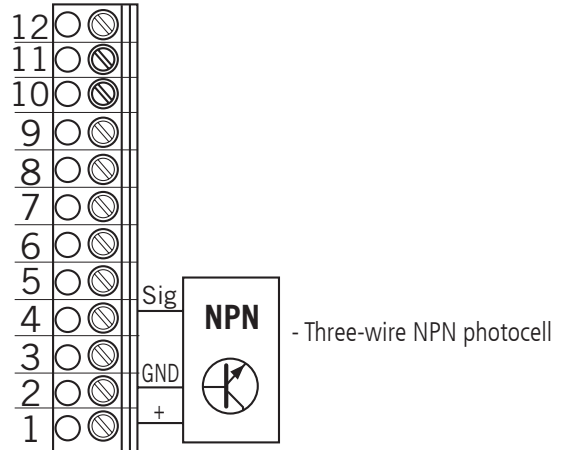

Terminal block X4

Three-wire PNP photocell

Parameter LIGHT BARR. 1 = MOD 3

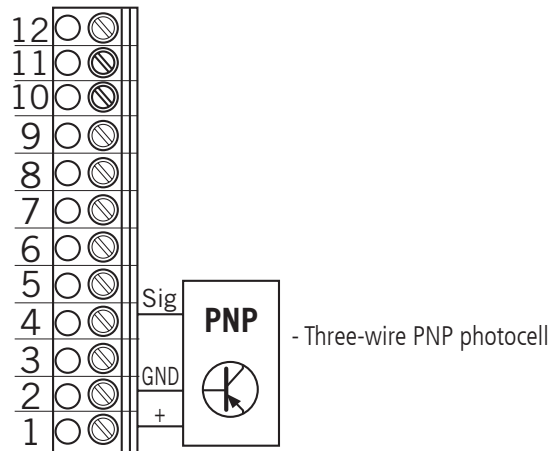

NOTICE:

All photocells are active for the OPENING or CLOSING direction, depending on the setting.

→ "10.2 Input operating mode"

Initial operation

5.10 Light curtain connection

Up to two light curtains can be connected to the CS 310. Light curtain 1 is connected to the input of the closing edge safety device and can be either an OSE or PNP system.

Terminal block X4

Light curtain 1

Version A: OSE (parameter SKS = MOD4)

The connecting cable (A) can be plugged in.

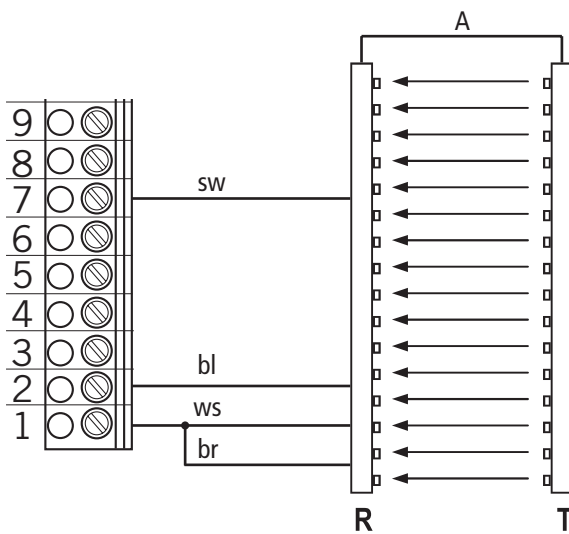

Version B: PNP (parameter SKS = MOD5)

The connecting cable (A) can be plugged in.

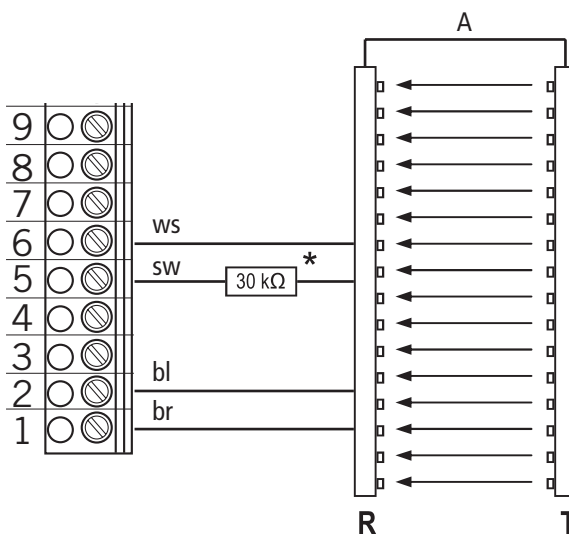

* The resistor (30kΩ) is included in the supply package.

Light curtain 2 (parameter INPUT2 = MOD7)

Light curtain 2 is connected to the programmable INPUT 2 and must be a PNP system.

The connecting cable (A) can be plugged in.

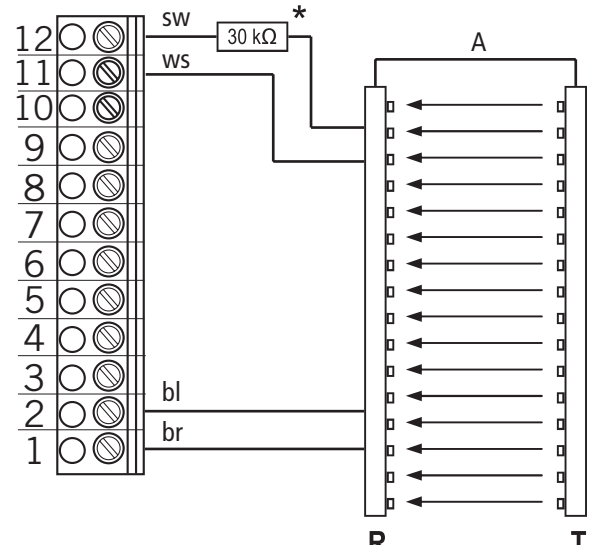

* The resistor (30kΩ) is included in the supply package.

br: brown
bl: blue
sw: black
ws: white

NOTICE:

The light curtain shown as an example in these instructions is the RAY-LG, manufactured by FRABA/CEDES.

RAY-LG 25xx OSE
RAY-LG 15xx PNP

In the case of the PNP system, the resistor (30kΩ) is included in the supply package and must be wired into the system without fail.

Testing of the FRABA/CEDES RAY-LG 15xx PNP light curtain takes place cyclically at the upper end position and before every hazardous movement. No relay output is necessary in this case.

No testing is required for the RAY-LG 25xx OSE light curtain.

Drawings from other manufacturers are available on enquiry.

5.11 Connection of programmable inputs

The CS 310 control has two programmable inputs, for which various functions can be selected.

→ "10.2 Input operating mode"

⚠ ATTENTION!

Danger of damage to the circuit board due to incorrect connection!

Inputs 1 and 2 have a different reference potential and they must NOT be operated from the same potential!

Terminal block X4

Programmable inputs
 Input 1: Terminal 9 + 10
 Input 2: Terminal 11 + 12

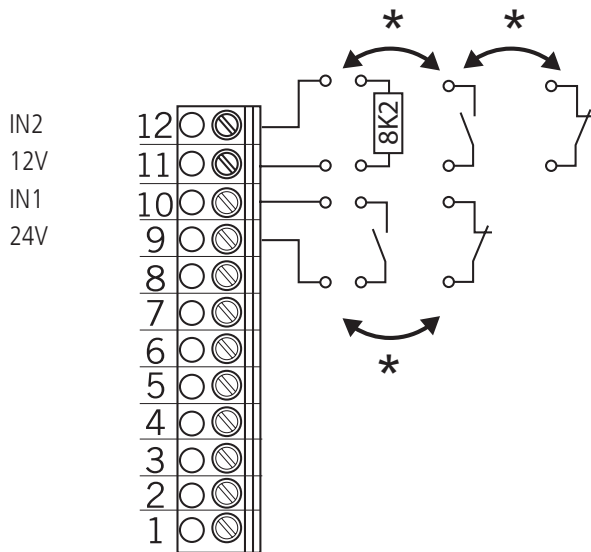

IN1 Input 1
 IN2 Input 2
 either/or

The type of wiring depends on the parameter settings for both inputs in INPUT mode.

5.12 Connection arrangement for relay outputs

Four potential-free relay outputs are available which can be programmed for various types of function.

→ "10.2 Input operating mode"

Terminal block X5

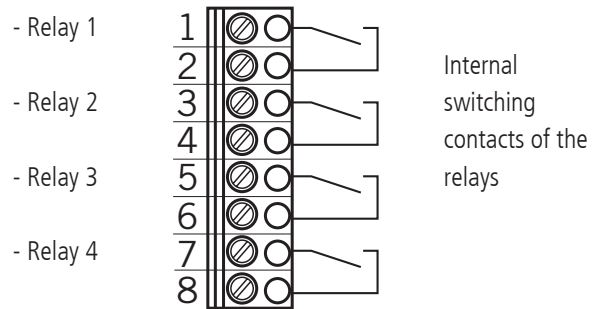

These four relay outputs are potential-free and have a maximum capacity of 4A at 230V/1~.

The type of function depends on the parameter setting for the corresponding relay output in INPUT mode.

Initial operation

5.13 CS radio

Terminal block X9

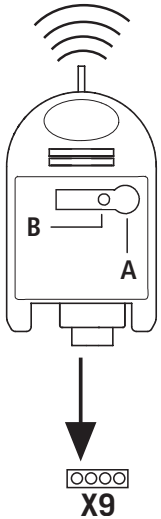

Connection

Insert the plug-in receiver into plug-in socket X9.

Teaching-in the transmitter codes

Press the programming button (A) and hold for more than 1.6 seconds. The programming mode is activated. The LED (B) flashes.

Press the channel button on your transmitter.

Once the remote control has saved the transmitter code, the LED lights up for approximately 4 seconds.

It is possible to teach-in up to 15 transmitter codes. If all memory spaces are full, the LED flashes rapidly.

Selectively deleting a transmitter code

Press the programming button (A) and hold for more than 1.6 seconds. The programming mode is activated.

The LED (B) flashes.

Keep pressing the programming button. The delete mode is activated. The LED flashes very fast.

Press the required channel button on your transmitter. When the LED lights up for approximately 4 seconds, the transmitter code in question has been deleted.

The deletion procedure can be cancelled by briefly pressing the programming button.

RESET (delete entire memory)

Press the programming button (A) and hold for more than 1.6 seconds. The programming mode is activated.

The LED (B) flashes.

Keep pressing the programming button. The delete mode is activated. The LED flashes very fast.

Press the programming button again for more than 1.6 seconds. When the LED lights up for approximately 4 seconds, all of the memory spaces have been deleted.

The deletion procedure can be cancelled by briefly pressing the programming button.

5.14 Connection of LCD monitor

With the LCD monitor, you have complete access to all of the menu settings and parameters of the control unit.

→ "8. Programming"

Plug-in socket X8

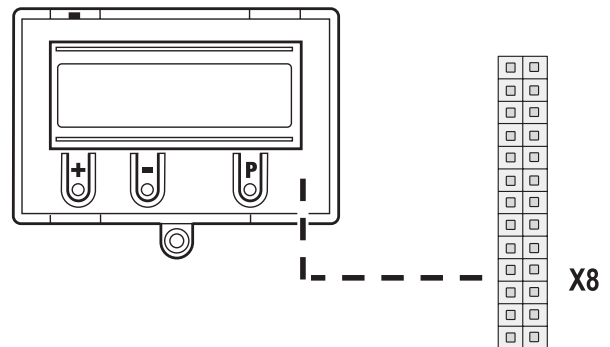

⚠ ATTENTION!

Damage can occur through improper installation!

The mains power supply must be switched off before connecting the LCD monitor. Only an Marantec LCD monitor (article number 91447) may be used.

⚠ ATTENTION!

Damage can occur through improper installation!

The Marantec LED module (article number 103239) cannot be combined with the CS 310. Inserting this module and putting it into service can damage the CS 310 circuit board beyond repair.

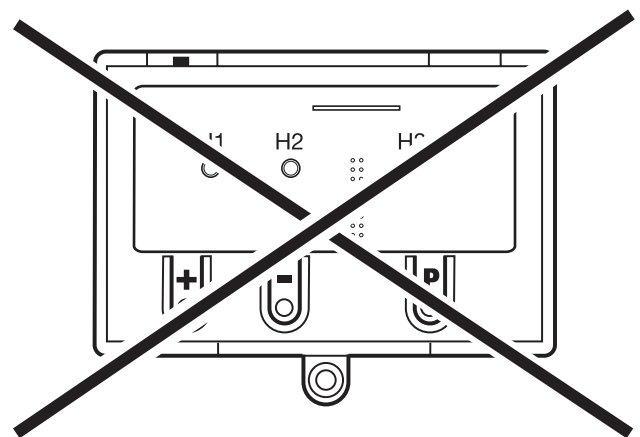

5.15 Connection of MS BUS modules

The MS BUS function modules allow you to expand the existing functions or add further functions.

- ES Module: Evaluation of draw in protection systems
- I/O Module: Input/Output expansion
- GV Module: Two-way traffic control

X16 / X17 sockets

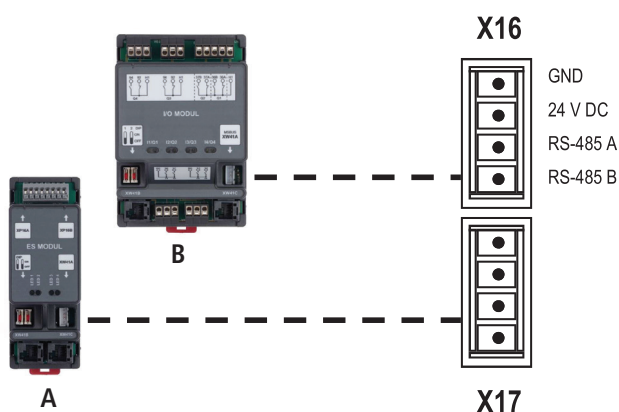

- A ES Module
- B I/O Module / GV Module

REFERENCE

For a detailed description of the function and connection of the modules, see the separate documentation for the BUS modules.

NOTICE:

Sockets X16 and X17 can be used only once. Taking the power consumption into account, however, it is possible to connect several BUS modules by using special jumper cables.

6. Initialisation

The following components will be recognised and taught-in automatically during initial operation and following a RESET.

- End position system
- Closing edge safety device
- Photocell system
- Input 2 (wicket door sensor)

During this process (approximately 60 seconds) the green LED flashes and the top line of the display shows the message "PLEASE WAIT ...".

It is not possible to operate the system during this process. The end position system must be installed before initial operation.

Components can be changed or added at a later date using the LCD display or by reinitialising the system.

If one of the components has not yet been connected, this will be indicated by "A" in the display.

This component will be searched for if any further initialisation procedure is carried out. If this component is recognised, the system automatically switches to the appropriate adjustment mode.

Exception:

Input 2 remains inactive (MOD1) if no 8.2 k Ω resistance was recognised the first time that initialisation was carried out. If an 8.2 k Ω resistance is detected at Input 2 during initial operation, it will be evaluated as a wicket door sensor and set in operation accordingly.

NOTICE:

In addition to "teaching in" the various system components, the initialisation process allows you to change the menu language directly.

The menu language pre-set in the factory (GERMAN) is displayed as a flashing text for approximately 60 seconds. The desired language can be selected using the [+] and [-] buttons and saved by pressing the [P] button. After this, all texts or messages displayed are shown in the language that you have selected.

7. Setting the end positions

7.1 Checking the direction of rotation/ direction of travel

Changing to adjustment mode

☞ Press button (P) until ADJUSTMENT appears.

Checking the direction of travel

☞ Press the (+) button. The door should open.

☞ Press the (–) button. The door should close.

If correct, continue with setting the end positions. If not, change the direction of travel.

Changing the direction of travel

☞ Press buttons (+) and (–) at the same time and hold for longer than 5 seconds. The display shows "ROT FIELD LEFT".

Any end positions that have been saved will be deleted.

Continue with setting the end positions.

7.2 Setting the mechanical limit switches

Changing to adjustment mode

☞ Press button (P) until ADJUSTMENT appears.

Setting the OPEN and CLOSED end positions

REFERENCE

The procedure for setting the end positions is described in separate documentation for mechanical limit switches.

☞ Exit the ADJUSTMENT mode by pressing button (P).

Please note

ADJUSTMENT mode is not exited automatically. To return to normal operating mode, ADJUSTMENT mode must be exited by pressing button (P).

7.3 Setting the electronic end position system using the setting buttons on the circuit board

Changing to adjustment mode

☞ Press button (P) for approx. 5 seconds.

The red LED flashes slowly.

Set the OPEN end position

☞ Press the (+/–) buttons to move the door/gate to the desired OPEN end position.

☞ Save the end position setting by pressing button (P) and by additionally pressing the (+) button.

The red LED flashes rapidly for approx. 1 second.

Set the CLOSED end position

☞ Press the (+/–) buttons to move the door/gate to the desired CLOSED end position.

☞ Save the end position setting by pressing button (P) and by additionally pressing the (–) button.

The red LED flashes rapidly for approx. 1 second.

Adjustment mode is exited automatically.

The red LED goes out.

Please note

- The adjustment mode will end automatically after approximately 7 seconds if no key is pressed.
- When carrying out adjustments for the first time, it is necessary to teach-in both end positions. Otherwise, normal operation will not be possible.
- If an end position is corrected, the ADJUSTMENT menu can be exited by pressing button (P) once the teaching-in of the special end position has been completed.
- After programming the limit switches, the teach-in of the system running time is carried out automatically. The functions of the control are the same as in automatic mode.

7.4 Setting the electronic end position system using the LCD monitor

ATTENTION!

Damage to property or irreparable damage due to incorrect installation!

The power supply must be switched off before connecting the monitor. Only an Marantec monitor may be used.



At plug-in socket X8: LCD Monitor Standard (#91447)

At plug-in socket X14: LCD Monitor RS 485 (#121246)



Changing to adjustment mode

 Press button (P) until ADJUSTMENT appears.

Set the OPEN end position

-  Press the (+/-) buttons to move the door/gate to the desired OPEN end position.
-  Save the end position setting by pressing button (P) and by additionally pressing the (+) button.
"STORAGE UP" appears in the display.

Set the CLOSED end position

-  Press the (+/-) buttons to move the door/gate to the desired CLOSED end position.
-  Save the end position setting by pressing button (P) and by additionally pressing the (-) button.
"STORAGE DOWN" appears in the display.

Adjustment mode is exited automatically.

Please note



- The adjustment mode will end automatically after approximately 7 seconds if no key is pressed.
- When carrying out adjustments for the first time, it is necessary to teach-in both end positions. Otherwise, normal operation not be possible.
- If an end position is corrected, the ADJUSTMENT menu can be exited by pressing button (P) once the teaching-in of the special end position has been completed.
- After programming the limit switches, the teach-in of the system running time is carried out automatically. The display shows TEACH IN RUN. The functions of the control are the same as in automatic mode.

7.5 Setting the intermediate positions of the electronic end position system using the LCD monitor



In AUTOMATIC mode, move the door/gate to the desired position

 Press the (+/-) button to drive the door to the desired intermediate position (INC.P.OP or INC.P.CL).

Changing to Input mode

-  Press button (P) until INPUT appears.
-  Press buttons (+) and (-) at the same time for longer than 2 seconds. The first parameter appears in the second line of the display.

Saving the intermediate OPEN (INC.P.OP) or CLOSE (INC.P.CL) position

-  Press the (+/-) buttons until the parameter INC.P.OP or INC.P.CL appears.
The current value is A.
-  Press button (P) to adopt the current door/gate position as an intermediate position.
-  Save the intermediate position by pressing button (P) again.

Exiting Input mode

-  Press buttons (+) and (-) at the same time for approx. 1 seconds.
Input mode is exited.

Changing to automatic mode

 Press button (P) until AUTOMATIC appears.

Please note

- If an intermediate position requires to be corrected, the teach-in value can be altered in the INPUT menu or set to A again to allow a new teach-in procedure to be carried out.

8. Programming

8.1 Overview of the LCD monitor

ATTENTION!

Damage to property or irreparable damage due to incorrect installation!

The power supply must be switched off before connecting the monitor. Only an Marantec monitor may be used.

At plug-in socket X8: LCD Monitor Standard (#91447)

At plug-in socket X14: LCD Monitor RS 485 (#121246)

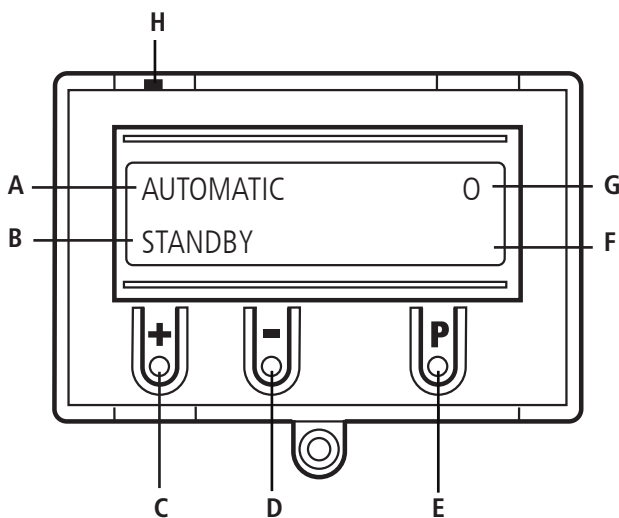

Key:

- A: Mode of operation / Diagnostics info
- B: Parameters / Diagnostics info
- C: Button (+)
- D: Button (-)
- E: Button (P)
- F: Value / Status
- G: Value / Status
- H: Jumper

If jumper H is removed, the (+) button, the (-) button and the (P) button have no function.

The display still functions.

After the control has been switched on, it will be in the initialisation phase and "PLEASE WAIT ..." will appear in the display. The control system is not ready for use. After switching on for the first time, the initialisation phase takes approximately 60 seconds.

8.2 LCD monitor, modes of operation

The control has four modes of operation with the LCD monitor:

1. AUTOMATIC
2. ADJUSTMENT
3. INPUT
4. DIAGNOSIS

ADJUSTMENT, INPUT and DIAGNOSIS modes are exited automatically 7 minutes after the last button was pressed. The control then goes into AUTOMATIC mode.

Operating mode 1: AUTOMATIC

The door/gate system is operated in the AUTOMATIC operating mode.

Display:

- Displays the action being carried out
- Displays any error messages

If the "PRESS/REL" parameter is set to MOD2-6 in the input menu, the display changes from AUTOMATIC to MANUAL.

Operating mode 2: ADJUSTMENT

ADJUSTMENT mode is used for setting the OPEN/CLOSED end positions.

ATTENTION!

Malfunctions can occur as a result of incorrect operation of the control!

In ADJUSTMENT mode, the door will not stop automatically when it reaches the end position if an electronic end position system (AWG) is used. The door can be damaged if driven beyond the end position.

Fine adjustments can be made in the INPUT operating mode.

Display:

- The current end position value is shown

Operating mode 3: INPUT

In the INPUT operating mode, the values of various parameters can be altered.

Display:

- Displays the selected parameter
- Displays the programmed value / current status

Operating mode 4: DIAGNOSIS

In the DIAGNOSIS operating mode, door-specific checks can be queried.

Display:

- Displays the checks
- Displays the status of the checks

8.3 Expert menu

In the factory setting (standard), INPUT mode shows only a few parameters that can be set by the user. These settings parameters reflect the most commonly used requirements for a commercial door/gate system and are adequate for commissioning purposes in a standard situation.

The last item in this list is the parameter "EXPERT MENU".

The default setting for this is OFF

OFF: Limited number of parameter settings:

- Menu language
- INC.P.OP
- OPEN TIME
- FOREWARNING
- FAST CL.
- REVERSPPOINT.
- INPUT 1
- SELF LOCK
- EXPERT MENU

Setting the parameter EXPERT MENU to ON activates expert mode. In this mode, all parameters in the input menu can be called up and set.

→ "10.2 Input operating mode"

Please note

- Expert mode is automatically closed after approx. 7 minutes if no buttons are pressed. In this case, only the limited choice of parameters is available unless the parameter EXPERT MENU is set to ON again.
- The same applies for switching the power off. In this case, too, the parameter EXPERT MODE is set to OFF again.

Programming

8.4 RESET

The RESET function allows you to return the control parameters to the original factory settings.

→ "10.2 Input operating mode"

FACTORY SET. parameter

Selecting the set of parameters that you want to RESET to.

Different types of reset can be carried out, allowing you to reset more or fewer of the settings.

→ "10.2 Input operating mode"

RESET parameter

Partial reset 1:

All of the parameter settings are reset except the settings for the frequency converter (applies only to CS310 FU).

Partial reset 2:

All of the parameter settings are reset except the settings for the end positions and the recognised end position system.

Complete reset:

Everything is returned to the factory default settings.

→ "8.5 RESETTING the control using the LCD monitor"

→ "8.6 RESETTING the control without an LCD monitor"

8.5 RESETTING the control using the LCD monitor

Switch to INPUT mode.

- Press the (P) button until "INPUT" appears in the display.
- Press buttons (+) and (-) for longer than 2 seconds to activate the Input.

Reset the control

- Press the (+/-) buttons until the "RESET" parameter appears in the display.
The value is set to "OFF".
- Press the (+) button until MOD4 appears in the display.
- Press button (P) to begin the RESET.

The initialisation phase takes place, and the end position system and all of the safety components that are connected are automatically taught in.

Changing to adjustment mode

→ "7.4 Setting the electronic end position system using the LCD monitor"

Changing to automatic mode

- Press the (P) button until "AUTOMATIC" appears in the display.

8.6 RESETTING the control without an LCD monitor

- Disconnect the system from the power supply.
- Press the circuit board buttons (P) and (-) at the same time and keep them pressed.
- Switch the power supply back on again.
- Press the circuit board buttons (P) and (-) at the same time and keep them pressed until the red LED (H6) flashes quickly.
- Release the circuit board buttons (P) and (-).

The initialisation phase will then take place (approximately 60 seconds).

While initialisation is being carried out, it is not possible to programme or operate the system.

Once initialisation has been successfully completed, the end positions have then been deleted and all parameters have been reset to their factory default settings.

9. Navigator (LCD monitor only)

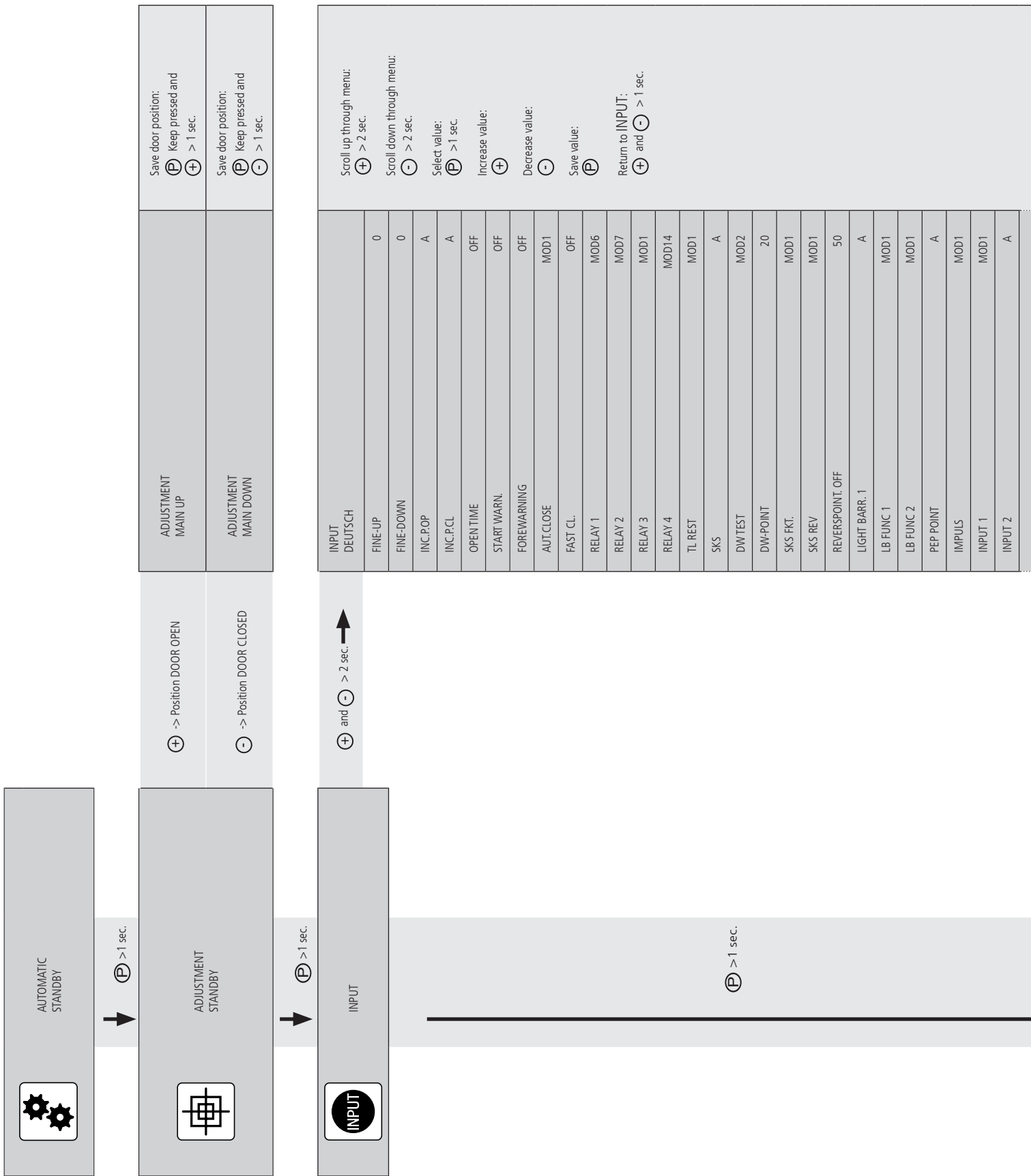

SKS3	MOD1
SKS4	MOD1
RUNNINGTIME	A
AROUNDTIME	300
LIMIT SW.	A
SELF LOCK	MOD1
POWER	10
RESET MSBUS	OFF
RESTART	OFF
FACTORY SET.	99
RESET	OFF
PIN NO.2	1111
SERVICE	OFF
INVERTER	MOD1
EXPERT MENU	OFF



DIAGNOSIS

ES UP	ON
ES DOWN	ON
OPEN BUTTON	OFF
CLOSE BUTTON	OFF
INPUT 1	OFF
INPUT 2	- / OFF
SKS	ON
SKS 3	- / ON
SKS 4	- / ON
IMPULS	OFF
SWITCH CLOCK	OFF
LIGHT BARR.	ON
LIGHT BARR2	ON
SAFETY CIRC.	ON
STOP	ON
ROT FIELD	Right
CYCLE	000000
SERVICE	OFF
AWG	0000
Error Memory	Error ...

Scroll up through menu:
 > 2 sec.

Scroll down through menu:
 > 2 sec.

Return to AUTOMATIC:

Only queries are possible.

10. Overview of functions

10.1 Automatic operating mode

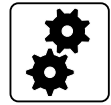

Display		Description
AUTOMATIC TEACH IN RUN		Automatic teach-in of the running time
AUTOMATIC OPEN		The door is in the opening phase.
AUTOMATIC CLOSE		The door is in the closing phase.
AUTOMATIC STANDBY		The door is at an intermediate position.
AUTOMATIC STANDBY	O	The door is at the OPEN end position.
AUTOMATIC STANDBY	o	The door is at the part OPEN position ("INC.P.OP" or "Intermediate OPEN position" parameter).
AUTOMATIC STANDBY	U	The door is at the CLOSED end position.
AUTOMATIC STANDBY	u	The door is at the part CLOSED position ("INC.P.CL." or "Intermediate CLOSED position" parameter).
AUTOMATIC STANDBY	r	The door is in the reversing switch-off position.
AUTOMATIC PERMANENT INPUT		A signal is permanently displayed. This can be a command device or a programmable input. This constitutes an invalid state under any circumstances. This state is probably caused by a faulty component which needs to be replaced. Exception: An exception to this is if the signal comes from the pluggable timer or the programmed input 1 when this is set to a timer function (MOD4) or fire alarm function (MOD5-9, 13).
AUTOMATIC CRASH-SENSOR		The crash sensor for the door/gate system has been activated (connection to X4/9-10, programmable input 1 MOD 18). Possibly a vehicle (such as a forklift truck) has driven into the closed door.

If the "PRESS/REL" parameter is set to MOD2, 3, 4, 5 or MOD6 in the input menu, the display changes from AUTOMATIC to MANUAL.

Display		Description
MANUAL MAIN UP		The door is in the opening phase.
MANUAL MAIN DOWN		The door is in the closing phase.
MANUAL STANDBY		The door is at an intermediate position.

10.2 Input operating mode



Function	Description	Setting options	Factory settings
DEUTSCH	Select the menu language. Only possible using the LCD monitor: Alternatively, the menu language can also be selected during the initialisation phase (during initial operation or after a reset). The menu language pre-set in the factory (DEUTSCH) appears here for approximately 60 seconds as flashing text in the display. At this point, the menu language can still be changed during the initialisation procedure. Pressing buttons [+] or [-] will allow you to scroll through and select a language. Save the language you have selected by pressing button [P]. After this, all texts or messages displayed are shown in the language that you have selected.	DEUTSCH ENGLISH FRANCAIS NEDERLANDS DANSK ESPANOL POLSKI CESKY ITALIANO SUOMI SVENSKA TÜRKÇE NORSK MAGYARUL	DEUTSCH
FINE-UP	Fine adjustment of the OPEN end position in relation to the saved OPEN end position (UPPER SWITCH). Only visible if an electronic end position system is used.	-250 – 250	0
FINE-DOWN	Fine adjustment of the CLOSED end position in relation to the saved CLOSED end position (LOWER SWITCH). Only visible if an electronic end position system is used.	-250 – 250	0
INC.P.OP	Setting the switching point for the intermediate OPEN position (Part OPEN) in relation to the saved OPEN end position. Displayed as a negative value. Only visible if an electronic end position system is used. Automatic teach-in of position: → "7.5 Setting the intermediate positions of the electronic end position system using the LCD monitor"	A (teach-in) -1 – LOWER SWITCH	A
INC.P.CL	Setting the switching point for the intermediate CLOSE position (Part CLOSED) in relation to the saved CLOSED end position. Displayed as a positive value. Only visible if an electronic end position system is used. Automatic teach-in of position: → "7.5 Setting the intermediate positions of the electronic end position system using the LCD monitor"	A (teach-in) 1 – UPPER SWITCH	A
OPEN TIME	After the door/gate has opened, it runs back automatically in the CLOSE direction after the set time has elapsed. Please note: If you press the CLOSE BUTTON during the open time, the closing run starts immediately. If you press the OPEN or STOP button during the open time, the time starts counting from the beginning again. If an automatic closing movement is interrupted by the SKS, the open time is added on with each new attempt. After 3 attempts, the automatic closing process will be aborted automatically.	OFF, 1 – 3600 seconds	OFF
START WARN.	The start warning is carried out before each run.	OFF, 1 – 10 seconds	OFF

Overview of functions

Function	Description	Setting options	Factory settings
FORE-WARNING	The forewarning is activated before an automatic closing run starts and before closing in impulse mode. Please note: This time is added to the start warning.	OFF, 1 – 300 seconds	OFF
AUT.CLOSE	Automatic closing after the open time has elapsed. MOD1: AUT.CLOSE from OPEN end position MOD2: AUT.CLOSE from end position Part OPEN MOD3: AUT.CLOSE from OPEN end position and Part OPEN end position MOD4: AUT.CLOSE from all door/gate positions	MOD1 – MOD4	MOD1
FAST CL.	Earlier closing after the photocell has been driven past. Requirements: A photocell must be installed at passage height and an open time greater than 0 must have been programmed. MOD2: The open time is cut short after the photocell (door closes immediately). If the photocell is driven through during an opening run, the programmed open time is ignored and the door closes immediately. MOD3: The open time is cut short after the photocell beam has been interrupted for a minimum of 2 seconds (in order to discount pedestrian traffic). If the photocell is driven through during an opening run, the programmed open time is ignored and the door closes immediately. MOD4: As for MOD2, except that the photocell has no function during the opening run.	OFF, MOD2 – MOD4	OFF
RELAY 1	A relay mode from 1 – 13, 17 – 19, 21 – 43 and 60 – 62 can be assigned to all four relays. Relay 4 can also be programmed with MOD14 – 16. Further explanations: → "Explanation of the relay modes:" on page 32	MOD1 – MOD13 MOD17 – MOD19 MOD21 – MOD43 MOD60 – MOD62	MOD6
RELAY 2	MOD1: (Red traffic light 1) flashes during forewarning and is ON during door run* MOD2: (Red traffic light 2) flashes during forewarning and during door run* MOD3: (Red traffic light 3) is ON during forewarning and during door run* MOD4: Impulse signal when OPEN command is given from inside MOD5: Error message MOD6: OPEN end position MOD7: CLOSED end position MOD8: OPEN end position negated MOD9: CLOSED end position negated MOD10: Intermediate OPEN position	MOD1 – MOD13 MOD17 – MOD19 MOD21 – MOD43 MOD60 – MOD62	MOD7
RELAY 3	MOD11: Intermediate CLOSE position MOD12: Intermediate CLOSE position to CLOSED end position MOD13: Magnetic lock function MOD14: Brake (normally energised mode) MOD15: Brake (normally de-energised mode) MOD16: Brake (normally energised mode) switched on in OPEN end position MOD17: SKS activated or test error	MOD1 – MOD13 MOD17 – MOD19 MOD21 – MOD43 MOD60 – MOD62	MOD1
RELAY 4	MOD18: (Red traffic light 4) flashes during forewarning and is OFF during door run MOD19: Intermediate OPEN position to OPEN end position MOD21: Test of draw-in protection before opening run (additional module required) MOD22: Activation of radio transmission systems 1 and 3 and/or light curtain testing MOD23: (Green traffic light) is ON at OPEN end position, OFF during forewarning and OFF during door run* MOD24: Capacitor switching for 230 V/1~ sectional-door operators MOD25: Yard light function, light stays on for 2 minutes after OPEN impulse/ command MOD26: Activation of radio 2 transmission system MOD27: Impulse signal when OPEN end position is reached MOD28: Relay generally OFF MOD29: Door opens MOD30: Door closes	MOD1 – MOD19 MOD21 – MOD43 MOD60 – MOD62	MOD14

Function	Description	Setting options	Factory settings
	<p>MOD31: Service, continuous signal once the pre-set maintenance interval is reached</p> <p>MOD32: Battery mode</p> <p>MOD33: Battery operation not possible</p> <p>MOD34: Fire alarm signal (fire detection and alarm system (BMA) active)</p> <p>MOD35: Photocell operative</p> <p>MOD36: Wicket door locking cylinder</p> <p>MOD37: Testing of stop signal through radio transmission systems 1 and 3</p> <p>MOD38: Testing of light curtain 2 (input 2)</p> <p>MOD39: LED error</p> <p>MOD40: Impulse signal when OPEN command is given from outside</p> <p>MOD41: Test of radio transmission system 4 in OPEN direction</p> <p>MOD43: Operator in motion</p> <p>MOD60: (Red traffic light, outside) flashes during forewarning and is ON during door run</p> <p>MOD61: (Red traffic light outside) flashes during forewarning and during door run</p> <p>MOD62: (Green traffic light outside) ON at OPEN end position, OFF during forewarning, and OFF during door run</p> <p>* If two-way traffic control is activated: Traffic light INSIDE</p>		
T-LI. REST	<p>Switches traffic lights</p> <p>MOD1: OFF in standby mode</p> <p>MOD2: ON in standby mode</p> <p>MOD3: In standby OFF after 5 minutes</p>	MOD1 – MOD3	MOD1
SKS	<p>MOD1: OSE (optosensor)</p> <p>MOD2: 8.2 kΩ (electrical contact strip)</p> <p>MOD3: DW Pressure sensor (airwave bar) as NC with testing</p> <p>MOD4: Optosensor (OSE) light curtain without testing</p> <p>MOD5: PNP light curtain with testing</p> <p>MOD6: PNP light curtain without testing</p> <p>NOTICE: MOD4, MOD5 and MOD6 must be set manually if a light curtain is used. – Without any addition to the open time (if programmed) after the light curtain has been interrupted during automatic closing. – Without switching off "Automatic closing" after 3 interruptions in a row.</p>	A – self teach-in MOD1 – MOD6	A
DW TEST	<p>Activation and deactivation of testing function for the attached DW airwave bar. Only appears if parameter setting SKS = MOD3.</p> <p>MOD1: Test OFF</p> <p>MOD2: Test ON</p>	MOD1 – MOD2	MOD2
DW-POINT	<p>Point at which the DW airwave bar attached is tested (X4 / 5+6). Only appears if parameter setting SKS = MOD3.</p> <p>Setting is done in increments (only AWG), starting from the lower travel cut-out point. In systems with mechanical limit switches, the additional CLOSE limit switch serves as the PS-POINT.</p>	0 – 1000	20
SKS FUNC	<p>MOD1: Stop + reverse</p> <p>MOD2: Stop + 2-second reversing movement</p>	MOD1 – MOD2	MOD1

Overview of functions

Function	Description	Setting options	Factory settings																														
SKS REV	<p>MOD1: Stop + reverse between OPEN end position and reversing point Stop between reversing point and CLOSED end position → for vertically closing doors</p> <p>MOD2: Stop + reverse between OPEN end position and reversing point No action between reversing point and CLOSED end position → for vertically closing doors with leading photocell</p> <p>MOD3: Stop + reverse between OPEN end position and CLOSED end position → for horizontally closing doors and systems with mechanical limit switches without pre-limit switch</p> <p>NOTICE: In systems with mechanical limit switches, the additional CLOSE limit switch serves as the reversing point.</p>	MOD1 – MOD3	MOD1																														
REVERS-POINT. OFF	Reversing point. Point at which the reversing movement of the door is switched off. Appears only for systems with an electronic end position system (AWG). Setting is done in increments, starting from the lower travel cut-out point. In systems with mechanical limit switches, the additional CLOSE limit switch serves as the reversing point.	A – self teach-in 1 – 1000	50																														
LIGHT BARR. 1	<p>Photocell 1, installed in the drive-through area of the door. Connection to X4 / 1-4</p> <p>MOD1: Marantec 2-wire system MOD2: NC contact / NPN MOD3: PNP</p>	A – self teach-in MOD1 – MOD3	A																														
LB FUNC 1	<p>Function of photocell 1 in the drive-through area of the door.</p> <table border="0"> <thead> <tr> <th></th> <th>CLOSING door movement</th> <th>OPENING door movement</th> </tr> </thead> <tbody> <tr> <td>MOD1:</td> <td>Stop + reverse</td> <td>No action</td> </tr> <tr> <td>MOD2:</td> <td>Stop + short reversal</td> <td>No action</td> </tr> <tr> <td>MOD3:</td> <td>STOP</td> <td>No action</td> </tr> <tr> <td>MOD4:</td> <td>STOP</td> <td>STOP</td> </tr> <tr> <td>MOD5:</td> <td>Stop + reverse</td> <td>Dragging up suppression (Door OPENING movement not possible until the photocell is no longer interrupted).</td> </tr> <tr> <td>MOD6:</td> <td>No action</td> <td>Stop + reverse</td> </tr> <tr> <td>MOD7:</td> <td>No action</td> <td>Stop + short reversal</td> </tr> <tr> <td>MOD8:</td> <td>No action</td> <td>Stop</td> </tr> <tr> <td>MOD9:</td> <td>Dragging up suppression (Door CLOSING movement not possible until the photocell is no longer interrupted).</td> <td>Stop + reverse</td> </tr> </tbody> </table>		CLOSING door movement	OPENING door movement	MOD1:	Stop + reverse	No action	MOD2:	Stop + short reversal	No action	MOD3:	STOP	No action	MOD4:	STOP	STOP	MOD5:	Stop + reverse	Dragging up suppression (Door OPENING movement not possible until the photocell is no longer interrupted).	MOD6:	No action	Stop + reverse	MOD7:	No action	Stop + short reversal	MOD8:	No action	Stop	MOD9:	Dragging up suppression (Door CLOSING movement not possible until the photocell is no longer interrupted).	Stop + reverse	MOD1 – MOD9	MOD1
	CLOSING door movement	OPENING door movement																															
MOD1:	Stop + reverse	No action																															
MOD2:	Stop + short reversal	No action																															
MOD3:	STOP	No action																															
MOD4:	STOP	STOP																															
MOD5:	Stop + reverse	Dragging up suppression (Door OPENING movement not possible until the photocell is no longer interrupted).																															
MOD6:	No action	Stop + reverse																															
MOD7:	No action	Stop + short reversal																															
MOD8:	No action	Stop																															
MOD9:	Dragging up suppression (Door CLOSING movement not possible until the photocell is no longer interrupted).	Stop + reverse																															
LB FUNC 2	<p>Function of photocell 2 in the drive-through area of the door. Only appears if parameter setting INPUT 1 = MOD15. Connection only possible as an NC contact at programmable Input 1 (X4 / 9+10). Selection mode similar to the settings under LB FUNC. 1</p>	MOD1 – MOD9	MOD1																														
PEP POINT	<p>Photocell 1 (X4 / 1-4) is not evaluated between the CLOSED end position and the PEB POINT. Setting is done in increments, starting from the lower travel cut-out point. Only visible in systems with electronic limit switch.</p> <p>Please note: When adjusting, this point will be automatically recognised during the first closing run, provided that Photocell 1 is installed in the door frame and the photocell remains interrupted during the closing operation from this point through to the CLOSED end position.</p>	A – teach-in 1 – UPPER SWITCH	A																														

Function	Description	Setting options	Factory settings
IMPULSE	<p>Select a function to be assigned to the impulse button (X3 / 7+8).</p> <p>MOD1: OPEN - STOP - CLOSE - STOP - OPEN - ... (sequence control) MOD2: OPEN if door is stationary / No action if door is opening Stop and OPEN if door is closing MOD3: OPEN if door is stationary / STOP if door is moving MOD4: OPEN if door is stationary / No action if door is moving MOD5: OPEN if door is stationary / CLOSE if door is at the OPEN end position</p>	MOD1 – MOD5	MOD1
INPUT 1	<p>Select a function to be assigned to Input 1 (X4 / 9+10).</p> <p>MOD1: Part OPEN button MOD2: Part OPEN switch MOD3: AUTO CLOSE switch MOD4: External CLOCK (Continuous OPEN) MOD5: Fire alarm (BMA) switch 3 (partial opening) NO MOD6: Fire alarm (BMA) switch 1 (emergency closing) NO MOD7: Fire alarm (BMA) switch 1 (emergency closing) NC MOD8: Fire alarm (BMA) switch 2 (emergency opening) NO MOD9: Fire alarm (BMA) switch 2 (emergency opening) NC MOD10: Ventilation button (partial opening) NO MOD11: Automatic closing button MOD12: Laser scanner (special solution) MOD13: Fire alarm (BMA) switch 3 (partial opening) NC MOD14: Wicket door lock MOD15: Photocell 2 NC MOD16: Forewarning switch MOD17: Impulse button MOD18: Crash sensor NC MOD30: OPEN button inside MOD31: OPEN button outside MOD32: CLOSE button (Only active with operational closing edge safety device and operational Photocell 1. No function in deadman mode.)</p>	MOD1 – MOD18 MOD30 – MOD32	MOD1
INPUT 2	<p>Select a function to be assigned to Input 2 (X4 / 11+12).</p> <p>OFF: NOT active MOD2: Wicket door switch 8.2 kΩ Stop if there is deviation MOD3: Closing edge safety device OPEN 8.2 kΩ, active in the OPEN direction Stop and reverse when triggered MOD4: Closing edge safety device 8.2 kΩ, active in the OPEN direction Stop and short reversal when triggered MOD5: Battery mode MOD6: Radar motion detectors (special solution) MOD7: Light curtain 2 (PNP)</p> <p>During initial operation and after a reset, Input 2 will be set once to A – self teach-in. If no connected components are recognised, the input will be automatically deactivated. OFF appears in the display and the input must be manually activated.</p>	A – self teach-in OFF MOD2 – MOD7	A
SKS3	<p>Setting for Channel 1 of the plug-in signal transmission system (X20).</p> <p>OFF: not active MOD2: Activated as closing edge safety device in the CLOSE direction. MOD3: Activated as closing edge safety device in the OPEN direction. MOD4: Activated as safety device (internal safety circuit)</p>	OFF MOD2 – MOD4	OFF
SKS4	<p>Setting for Channel 2 of the plug-in signal transmission system (X20). Selection mode similar to the settings under SKS 3.</p>	OFF MOD2 – MOD4	OFF

Overview of functions

Function	Description	Setting options	Factory settings
RUNNING-TIME	Monitoring the maximum running time for an OPEN or CLOSE movement. The running time is determined automatically during the teach-in run. In the event of a 20% deviation (in both directions) an ERROR RUNTIME appears. After the automatic teach-in, the running time can be manually changed.	A – self teach-in OFF 1 – 300 seconds	A
AROUNDTIME	Motor stoppage time each time the door changes direction. When the closing edge safety device is triggered during the closing movement, the turnaround time amounts to a quarter of the programmed time.	100 – 5000 milliseconds	300
LIMIT SW.	Select the end position system to be evaluated. MOD1: Absolute value encoder (AWG) MOD2: Mechanical limit switch (MEC) MOD3: Without function MOD4: Only for operation with frequency converter (FU) MOD5: Absolute value encoder (AWG) + CLOSED mechanical limit switch (NC) in standard installation MOD6: Absolute value encoder (AWG) + CLOSED mechanical limit switch (NC) in special installation with an anti-clockwise rotating field MOD 5+6 (optional): In this case, an additional external mechanical limit switch is set for querying the lower end point in order to balance out any tolerances caused by the door mechanics and/or the door curtain. Once the mechanical limit switch has been activated, the lower end position is deemed to have been reached, no matter what information is received from the absolute value encoder.	A – self teach-in MOD1 – MOD6	A
SELF LOCK	Choose between impulse and manual operation, with or without evaluation of closing edge safety device (CESD) and photocell system (LB). MOD1: Impulse operation for OPEN + CLOSE with SKS and LB MOD2: Manual operation for OPEN + CLOSE with SKS and LB MOD3: Manual operation for CLOSE with SKS and LB MOD4: Manual operation for OPEN with SKS and LB MOD5: Manual operation for OPEN + CLOSE without SKS and LB MOD6: Manual operation for CLOSE without SKS and LB	MOD1 – MOD6	MOD1
POWER CHECK	Automatic power monitoring (monitoring the rotational speed) Error message if the door/gate is unable to move freely or is obstructed. Setting the sensitivity for both directions of travel. A reading giving the power value (rotational speed) is shown during opening and closing runs. If the power monitoring facility is activated, a value must be set that is lower than the lowest value displayed during door/gate travel. The larger the difference compared to the lowest value displayed, the less sensitively the power monitoring reacts. The power monitoring facility is only activated if a value has been set.	OFF 1 – 999	10
RESET MSBUS	All MSBUS addresses assigned will be reset. After restarting the control, all MSBUS devices connected will be re-addressed. → Refer to the instruction manual for the MSBUS device for detailed information.	ON OFF	OFF
RESTART	Control is restarted if function is activated.	ON OFF	OFF

Function	Description	Setting options	Factory settings
FACTORY SET.	<p>Selecting the set of parameters that you want to reset to.</p> <p>MOD5: Marantec S → Operators in deadman operation MOD6: Marantec FU → Operators of the MDF-U range (integrated UPS) MOD7: Marantec S → Operators of the STAW range with increased duty cycle MOD8: Marantec FU → Operators of the Marantec 05 range (230V) MOD9: Marantec FU → Operators of the STA range MOD14: Marantec FU → Operators of the Marantec 05 range (400V) MOD99: Marantec S → Standard MOD10 – MOD 98: Customer-specific parameter sets</p>	<p>MOD5 – MOD14 MOD10 – MOD98 MOD99</p>	MOD99
RESET	<p>Reset the control parameters to the pre-set factory settings</p> <p>MOD2: Partial reset 1 (everything except the frequency converter settings) MOD3: Partial reset 2 (everything except the end positions / end position system) MOD4: Total reset (everything is returned to factory default setting)</p>	<p>OFF, MOD2 – MOD4</p>	OFF
PIN NO. 2	<p>Input and selection of a PIN code for programming a maintenance interval. After entering the PIN code, the second programming level is opened. A maintenance interval can now be input at the parameter SERVICE. Input level 2 goes off again after the power has been switched off, or goes off automatically after 10 minutes. The PIN code can only be changed at the second programming level.</p>	0 – 9999	1111
SERVICE	<p>OFF: Maintenance indicator not activated</p> <p>Setting a maintenance interval. After the pre-set number of door cycles has been carried out, a maintenance message (LED / LCD) is given. If a relay output is programmed to MOD31, the relay concerned is triggered (continuous signal). Only appears after input level 2 has been activated via parameter PIN NO. 2.</p>	<p>OFF 0 – 99999</p>	OFF
INVERTER	<p>Activates or deactivates a connected frequency converter. If a frequency converter is connected at the X18 interface, the control becomes a CS 310 FU control. → Refer to the CS310 FU instruction manual for detailed information.</p> <p>MOD1: Operation without frequency converter MOD2: Operation with frequency converter MOD3: Operation with frequency converter (effective ramp times)</p>	MOD1 – MOD3	MOD1
EXPERT MENU	<p>Activation and deactivation of expert setting.</p> <p>In the factory setting OFF, only a limited choice of parameters appears in INPUT mode. If this parameter is set to ON, all parameters in the input menu can be called up and set.</p> <p>OFF: Limited number of parameter settings:</p> <ul style="list-style-type: none"> – Menu language – INC.P.OP – OPEN TIME – FOREWARNING – FAST CL. – REVERS- POINT. – INPUT 1 – SELF LOCK – EXPERT MENU <p>ON: Access to all parameters as listed in Chapter 10.2.</p>	ON – OFF	OFF

Overview of functions

Explanation of the relay modes:

A. Traffic light functions

MOD	Description	CLOSED end position	OPEN end position	Forewarning	Door run
MOD1	Red traffic light 1 ³	ON / OFF ¹	OFF ²	Flashing	Lit up
MOD2	Red traffic light 2 ³	ON / OFF ¹	OFF ²	Flashing	Flashing
MOD3	Red traffic light 3 ³	ON / OFF ¹	OFF ²	Lit up	Lit up
MOD18	Red traffic light 4 ³	OFF	OFF	Flashing	OFF
MOD23	Green traffic light ³	OFF	ON ²	OFF	OFF
MOD60	Red traffic light 1 ⁴	ON / OFF ¹	OFF ²	Flashing	Lit up
MOD61	Red traffic light 2 ⁴	ON / OFF ¹	OFF ²	Flashing	Flashing
MOD62	Green traffic light ⁴	OFF	ON ²	OFF	OFF

¹ Dependent on parameter T-LI. REST

² If two-way traffic control is activated: dependent on inside or outside OPEN command

³ If two-way traffic control is activated: traffic light inside

⁴ If two-way traffic control is activated: traffic light outside

B. Position messages

MOD	Description	Remarks
MOD6	OPEN end position	The relay closes the contact when the door is at the OPEN end position.
MOD7	CLOSED end position	The relay closes the contact when the door is at the CLOSED end position.
MOD8	Not OPEN end position	The relay closes the contact when the door is not at the OPEN end position.
MOD9	Not CLOSED end position	The relay closes the contact when the door is not at the CLOSED end position.
MOD10	Intermediate OPEN position (Part OPEN)	The relay closes the contact when the door is at the intermediate OPEN position (part OPEN).
MOD11	Intermediate CLOSE position (Part CLOSED)	The relay closes the contact when the door is at the intermediate CLOSE position (Part CLOSED).
MOD12	Intermediate CLOSE position to CLOSED end position	The relay closes the contact when the door is in the area between the CLOSED end position and the intermediate CLOSE position (Part CLOSED).
MOD19	Intermediate OPEN position to OPEN end position	The relay closes the contact when the door is in the area between the OPEN end position and the intermediate OPEN position (Part OPEN).

C. Impulse signals

MOD	Description	Remarks
MOD4	Impulse when OPEN command is given from inside	The relay closes the contact for 1 second when the door receives an OPEN command from inside. This impulse can be used to control lights, for instance.
MOD27	Impulse when OPEN end position is reached	The relay closes the contact for 2 seconds when the door reaches the OPEN end position. This impulse can be used, for instance, to open a following photocell.
MOD 40	Impulse when OPEN command is given from outside	The relay closes the contact for 1 second when the door receives an OPEN command from outside. This impulse can be used to control lights, for instance.

D. Brake functions (only adjustable on relay 4)

MOD	Description	Remarks
MOD14	Brake (normally energised mode)	The switching contact of the brake rectifier is activated via the relay to achieve a faster brake function. As soon as the door starts to move, the contact closes and the brake is released (normally energised mode).
MOD15	Brake (normally de-energised mode)	The switching contact of the brake rectifier is activated via the relay to achieve a faster brake function. As soon as the door starts to move, the contact opens and the brake is released (normally de-energised mode).
MOD16	Brake (normally energised mode) switched on in OPEN end position	The switching contact of the brake rectifier is activated via the relay to achieve a faster brake function. As soon as the door starts to move, the contact closes and the brake is released (normally energised mode). In order to stop the door/gate more smoothly at the OPEN END POSITION, the switching contact is not switched at the OPEN end position (OPEN TIME).

E. Error messages

MOD	Description	Remarks
MOD5	Error message	The relay opens the contact when a STOP command is given or an error occurs. All errors described in Section 10 result in actuation of the relay.
MOD17	Closing edge safety device actuated	The relay opens the contact when the closing edge safety device is actuated. An error in the closing edge safety device or an unsuccessful test is shown via MOD5.
MOD35	Photocell	As with photocell input X4 (3/4), the signal received is passed on in the form of a message. Relay ON: Photocell signal is OK Relay OFF: Light beam interrupted or fault in photocell
MOD39	LED error	The relay always closes the contact when the internal error LED 2 (red) lights up.

Overview of functions

F. Movement signal

MOD	Description	Remarks
MOD29	Door OPENS.	Active during OPENING movements.
MOD30	Door CLOSES.	Active during CLOSING movements.
MOD43	Door opens or closes.	Active during every movement.

G. Functions for external accessories

MOD	Description	Remarks
MOD13	Magnetic lock function	The relay closes before each door movement. The relay is normally open. A delay of 0.5 seconds is programmed to elapse before each door movement takes place.
MOD21	Test of draw-in protection	The relay generates a test signal when the CLOSED end position is reached and expects, as a reaction to the test signal, that the stop circuit is actuated.
MOD22	Activation of radio transmission systems 1 and 4, testing of light curtain 1	The relay generates a test signal when the OPEN end position is reached and expects, as a reaction to the test signal, that the closing edge safety device input is actuated.
MOD24	Capacitor	Whenever a door movement command is given, the relay closes for approximately 1 second. With the aid of this relay, an additional starting capacitor that is required for AC applications is switched on, to ensure safe starting of the motor. For operators of the STAW range with increased duty cycle.
MOD25	Yard light function	At every OPEN command, the relay is closed for 2 minutes and can therefore be used to control a light.
MOD26	Activation of radio transmission systems 2 and 4	Before every CLOSE command, the radio transmission system is activated by an impulse. The duration of the activation must be set on the transmission system. This activation results in a 0.5 second delay in starting.
MOD28	Relay OFF	The relay is generally switched off; the contact is always open.
MOD36	Pneumatic cylinder for locking the wicket door (threshold-less door system).	Every time an OPEN command is given, the relay is activated and controls a pneumatic cylinder which mechanically locks the wicket door that is incorporated in the door. The locking position of the cylinder is queried through a limit switch. The door starts moving only after this limit switch has been released. The relay remains activated until the lower end position has been reached again.
MOD37	Testing of the stop signal via radio transmission systems 1 and 3	The relay generates a test signal when the OPEN end position is reached and expects, as a reaction to the test signal, that the stop circuit is interrupted.
MOD38	Testing light curtain 2 (8.2 kΩ) Connection to input 2 (X4 / 11+12)	The relay generates a test signal when the OPEN end position is reached and expects, as a reaction to the test signal, that there is an interruption to Input 2.
MOD 41	Activation of radio transmission system 4 in the OPEN direction	The relay generates a test signal when the CLOSED end position is reached and expects, as a reaction to the test signal, that there is an interruption to Input 2.

H. Input-dependent messages

MOD	Description	Remarks
MOD32	Battery mode	Active during battery operation. Input 2 bridged (setting MOD5)
MOD33	Not in battery mode	Active during mains operation. Input 2 open (setting MOD5) When programmed with MOD32/33, the relays work as delayed change-over contacts and follow the signal at Input 2 if set to MOD5. In this case, input 2 is supplied with a control signal from the uninterruptible power supply (UPS) system which is responsible for switching between mains power and the UPS power supply.
MOD34	BMA signal	Triggered if fire alarm system (BMA) active. Follows the signal at Input 1 if set to MOD5-9 / 13. In this case, Input 1 is supplied with a control signal from the fire alarm system, and depending on the setting, opens or closes the door to an end position or an intermediate position.

Key to inputs:

A. Input 1 functions

MOD	Description	Remarks
MOD1	PART OPEN button	When the button is pressed (Input 1), the door opens as far as the intermediate OPEN position (PART OPEN).
MOD2	PART OPEN switch	Closed: All OPEN commands lead to the intermediate OPEN position (PART OPEN). Open: All OPEN commands lead to the OPEN end position.
MOD3	AUTO CLOSE switch	Closed: No automatic closing (open time continues, if open time > 0) Open: Automatic closing run is activated (if open time > 0)
MOD4	External CLOCK (Continuous OPEN)	The door opens once the contact closes and remains in the OPEN position (open time continues) until the contact opens. The door then closes automatically (only if open time > 0) This function can be aborted by pressing the CLOSE button. The gate CLOSES.
MOD5	Fire alarm (BMA) switch 3 (partial opening) NO	Control function if fire alarm system is active. Open: Normal operation Closed: Partial opening of the door. The intermediate OPEN position (Part OPEN) is approached from either direction, irrespective of the current door position. BUTTON: No function LIGHT BARR / SKS: Door stops and briefly reverses (only in CLOSING direction), and closes again after 5 seconds STOP: Emergency closing interrupted as long as this is activated
MOD6	Fire alarm (BMA) switch 1 (emergency closing) NO	Control function if fire alarm system is active. Open: Normal operation Closed: Emergency closing of door BUTTON: No function LIGHT BARR / SKS: Door stops and briefly reverses; emergency closing again after 5 seconds STOP: Emergency closing interrupted as long as this is activated

Overview of functions

MOD	Description	Remarks
MOD7	Fire alarm (BMA) switch 1 (emergency closing) NC	Control function if fire alarm system is active. Closed: Normal operation Open: Emergency closing of door BUTTON: No function LIGHT BARR / SKS: Door stops and briefly reverses; emergency closing again after 5 seconds STOP: Emergency closing interrupted as long as this is activated
MOD8	Fire alarm (BMA) switch 2 (emergency opening) NO	Control function if fire alarm system is active. Open: Normal operation Closed: Emergency opening of door BUTTON: No function LIGHT BARR / SKS: No function STOP: Emergency closing interrupted as long as this is activated. No automatic closing after deactivation of fire alarm signal.
MOD9	Fire alarm (BMA) switch 2 (emergency opening) NC	Control function if fire alarm system is active. Closed: Normal operation Open: Emergency opening of door BUTTON: No function LIGHT BARR / SKS: No function STOP: Emergency closing interrupted as long as this is activated. No automatic closing after deactivation of fire alarm signal.
MOD10	Ventilation button NO	Partial opening of the door. When an additional button at Input 1 is pressed, the intermediate CLOSE position (Part CLOSED) is approached from either direction, irrespective of the current door position.
MOD11	"Automatic closing" button	1. Operation: No automatic closing; the open time continues. 2. Operation: Automatic closing of the door is active again, if the open time is > 0. 3. Operation: No automatic closing; the open time continues. ...
MOD12	Laser scanner (height detection)	Only in conjunction with Input 2 (MOD 6). → See explanation regarding Input 2.
MOD13	Fire alarm (BMA) switch 3 (partial opening) NC	Control function if fire alarm system is active. Closed: Normal operation Open: Partial opening of the door. The intermediate OPEN position (PART OPEN) is approached from either direction, irrespective of the current door position. BUTTON: No function LIGHT BARR / SKS: Door stops and briefly reverses (only in CLOSING direction), and closes again after 5 seconds STOP: Emergency closing interrupted as long as this is activated.
MOD14	Wicket door lock	Monitoring limit switch for the pneumatic lock system for wicket doors. The limit switch must confirm correct locking within 10 seconds of an OPEN command being given, otherwise the door remains stationary and an error message is given. This function affects relay mode 36.
MOD15	Photocell 2 NC	If a second photocell is installed in the drive-through area of the door, this system can be programmed via the LB FUNC 2 parameter in INPUT mode. Only photocells with a potential-free NC contact may be connected.
MOD16	Forewarning switch	Closed: Start-up warning and forewarning are inactive (even if both times are > 0). Open: Start-up warning and forewarning are active (only when both times are > 0). → "10.2 Input operating mode" on page 25

MOD	Description	Remarks
MOD17	Impulse button outside	Pressing the button moves or stops the door. – The function and direction of the movement depend on the IMPULS parameter setting in the Input menu. → "10.2 Input operating mode" on page 25 – If two-way traffic control is activated, this impulse command is treated as a signal from outside.
MOD18	Crash sensor (NC)	Querying a crash sensor as a NC contact. If the crash sensor has been activated before, door operation is only possible again – if the STOP button has been pressed for longer than 5 seconds or – the supply voltage has been turned off and then on again.
MOD30	OPEN button inside	When the button is pressed, the door opens as far as the OPEN end position. The traffic light inside changes to green.
MOD31	OPEN button outside	When the button is pressed, the door opens as far as the OPEN end position. The traffic light outside changes to green.
MOD32	CLOSE button	When the button is pressed, the door closes as far as the CLOSED end position. Only active with operational closing edge safety device and operational photocell 1. No function in deadman mode.

B. Input 2 functions

MOD	Description	Remarks
OFF		not active
MOD2	Wicket door switch (8.2 k Ω)	Generally active Stops the system when actuated.
MOD3	Closing edge safety device OPEN (8.2 k Ω)	Closing edge safety device active in the OPEN direction Door stops and reverses to the CLOSED end position when the closing edge safety device is triggered.
MOD4	Closing edge safety device OPEN (8.2 k Ω)	Closing edge safety device active in the OPEN direction Door stops and moves in the CLOSE direction for 2 seconds (short reverse) when the closing edge safety device is triggered.
MOD5	Battery operation (MDFU special solution) n.o.	Active if power supplied by battery. Relay switching MOD32 / MOD33.
MOD6	Radar motion detector (height detection) NO	The function is coupled to Input 1 (MOD12 – laser scanner). The preceding laser scanner detects the height of the vehicle. The installed radar motion detector generates an OPEN command when actuated. – A tall vehicle (lorry) will be detected by the laser scanner. The laser scanner switches Input 1 (MOD12) to ON. The radar motion detector evaluates the vehicle and triggers the door movement. The door is moved to the OPEN end position. – A lower vehicle (car) is recognised by the laser scanner. The laser scanner switches Input 1 (MOD12) to OFF. The radar motion detector evaluates the vehicle and triggers the door movement. The door is moved to the intermediate OPEN position (Part OPEN). All other OPEN commands (via X3, X7, X9, X13) always move the door to the OPEN end position. The Input 1 function (MOD12) then has no effect.

Overview of functions

MOD	Description	Remarks
MOD7	Light curtain 2 (PNP)	Acts in same way as light curtain 1 (SKS MOD 4 – 6) <ul style="list-style-type: none">– Light curtain active in the CLOSE direction.– Stop and reverse when the light curtain is triggered. The type of reversing (reverse / short reversal) is also adopted.

10.3 Diagnosis / error memory operating mode



Display	Meaning	Status
UPPER SWITCH	OPEN end position	OFF: End position reached ON: End position not reached
LOWER SWITCH	CLOSED end position	OFF: End position reached ON: End position not reached
OPEN BUTTON	Command button / OPEN input	ON: Button activated / input is active OFF: Button not activated / input not active
CLOSE BUTTON	Command button / CLOSE input	ON: Button activated / input is active OFF: Button not activated / input not active
INPUT 1	INPUT 1 (X4 / 9 + 10)	ON: Input 1 active OFF: Input 1 not active
INPUT 2	INPUT 2 (X4 / 11 + 12)	ON: Input 2 active OFF: Input 2 not active —: Not activated
SKS	Closing edge safety device 1 (PS switch, 8.2k Ω or optosensor) or light curtain 1 (PNP or optosensor) (X4 / 5-8) CLOSING direction	ON: System closed OFF: System interrupted (fault)
SKS 3	Closing edge safety device 3 (8.2k Ω or optosensor) Radio transmission system channel 1 OPEN or CLOSE direction	ON: System closed OFF: System interrupted (fault) —: Not activated
SKS 4	Closing edge safety device 4 (8.2k Ω or optosensor) Radio transmission system channel 2 OPEN or CLOSE direction	ON: System closed OFF: System interrupted (fault) —: Not activated
IMPULS	Command button / IMPULSE input (X3 / 7+8)	ON: Button activated / input is active OFF: Button not activated / input not active
SWITCH CLOCK	Weekly timer (pluggable)	ON: Timer activated OFF: Timer not activated
LIGHT BARR.	Drive-through photocell 1 (X4 / 1-4)	ON: Photocell signal is OK OFF: Light beam interrupted or fault in photocell
LIGHT BARR. 2	Drive-through photocell 2 Connection to Input 1 (X4 / 9+10)	ON: Photocell signal is OK OFF: Light beam interrupted or fault in photocell
SAFETY CIRC.	Safety circuit 1 Emergency stop systems of door system	ON: Safety circuit closed OFF: Safety circuit interrupted
STOP	STOP command button (keypad on cover)	ON: Button not activated OFF: Button activated

Overview of functions

Display	Meaning	Status
ROT FIELD	Shows currently set rotational direction of door operator	RIGHT: Setting for clockwise rotating field LEFT: Setting for anticlockwise rotating field
CYCLE	Door cycle counter	Displays number of door cycles counted so far 1 x OPEN + 1 x CLOSE = 1 cycle Counts only if the travel cut-out points are reached.
SERVICE	Service alarm function Service alarm function parameters SERVICE and PIN NO. 2	OFF: Maintenance indicator not activated 0 – 99999: Maintenance indicator activated Displays the number of door cycles left until a maintenance message is sent
AWG	Shows position information of absolute value encoder	Displays the current transmitted value
ERROR ... COUNT CYCLE	Control unit error memory Error messages from the control unit can be read out here with information on the frequency and cycle. The list of error messages can be scrolled through using buttons [+] and [-] on the LCD monitor. → "11.1 Error messages shown on LCD display" Deleting the error log: Press buttons [+] and [-] at the same time for approximately 2 seconds. Every error message must be individually deleted.	The display changes every 2 seconds to show the following in turn: – the error description, – the frequency of occurrence and – the cycle in which the error last occurred. The list contains only errors which have already occurred before.

11.1 Error messages shown on LCD display

Fault / error message	Cause	Rectification
System does not respond	<ul style="list-style-type: none"> No voltage supply. 	<ul style="list-style-type: none"> Check the voltage supply to the door operator and the control.
<p>Door travels to the CLOSED end position when the OPEN button is pressed</p> <p>Door travels to the OPEN end position when the CLOSE button is pressed</p>	<ul style="list-style-type: none"> Rotating field is connected wrongly. 	<ul style="list-style-type: none"> Check the rotating field and set direction to clockwise, if necessary.
FAULT – X	<ul style="list-style-type: none"> internal software or hardware fault. 	<ul style="list-style-type: none"> RESET using the circuit board buttons: → "8.6 RESETTING the control without an LCD monitor"
SAFETY CIRC.	<ul style="list-style-type: none"> The safety circuit is interrupted. <ul style="list-style-type: none"> X3 / 1+2 Control safety circuit EMERGENCY STOP, slack rope switch X6 / 1+2 ON / OFF internal X11 / 4+8 Safety circuit of door operator AWG X14 / 8+4 Interface RS485 X2 / B1+B2 Safety circuit of door operator MEC X3 / 3+4 External stop button X7 / 1+2 Internal stop button 	<ul style="list-style-type: none"> Check safety circuit, localise interruption and rectify problem.
ERROR RUNTIME	<ul style="list-style-type: none"> The programmed running time has been exceeded. 	<ul style="list-style-type: none"> Check the path of the door and the running time. Re-programme the running time, if necessary.
ERROR AWG	<ul style="list-style-type: none"> Signal transmission between absolute value encoder and control interrupted and/or broken down. 	<ul style="list-style-type: none"> Check the cable and socket connections and replace, if necessary.
TERM SWITCH FAIL	<ul style="list-style-type: none"> The door has travelled beyond the programmed end position area. The end positions have not yet been programmed. 	<ul style="list-style-type: none"> Move the door/gate back into the programmed area using the emergency operation facility. First, programme the end positions.
ERROR REVOLUTION	<ul style="list-style-type: none"> The power monitoring has been triggered. 	<ul style="list-style-type: none"> Check the door for any mechanical impairment or damage.
ERROR DIRECTION	<ul style="list-style-type: none"> The rotating field present is not a clockwise rotating field. 	<ul style="list-style-type: none"> Check the rotating field And change the direction, if necessary. → "7.1 Checking the direction of rotation/direction of travel"
ERROR SKS CLS.	<ul style="list-style-type: none"> Closing edge safety device 1 is faulty in the CLOSING direction → (X4 / 5-8). 	<ul style="list-style-type: none"> Check the closing edge safety device and the spiral cable.
ERROR SKS OPEN 2	<ul style="list-style-type: none"> Closing edge safety device 2 is faulty in the OPEN direction → (X4 / 11+12) input 2 	<ul style="list-style-type: none"> Check the closing edge safety device and the spiral cable.
ERROR STOP 2	<ul style="list-style-type: none"> Safety circuit 2 is interrupted. Wicket door switch 8.2 kΩ → (X4 / 11+12) input 2 	<ul style="list-style-type: none"> Check wicket door switch.
ERROR SKS CLS. 3	<ul style="list-style-type: none"> Closing edge safety device 3 is faulty in the CLOSING direction → (X20) Plug-in RADIO transmission system channel 1 	<ul style="list-style-type: none"> Check closing edge safety device. Test the RADIO transmission system.

Error messages and rectification

Fault / error message	Cause	Rectification
ERROR SKS OPEN 3	<ul style="list-style-type: none"> – Closing edge safety device 3 is faulty in the Open direction → (X20) Plug-in RADIO transmission system channel 1 	<ul style="list-style-type: none"> – Check closing edge safety device. – Test the RADIO transmission system.
ERROR STOP 3	<ul style="list-style-type: none"> – Safety circuit 3 is interrupted. → (X20) Plug-in RADIO transmission system channel 1 	<ul style="list-style-type: none"> – Check the safety circuit. – Check the RADIO transmission system.
ERROR SKS CLS. 4	<ul style="list-style-type: none"> – Closing edge safety device 4 is faulty in the CLOSING direction → (X20) Plug-in RADIO transmission system channel 2 	<ul style="list-style-type: none"> – Check closing edge safety device. – Check the RADIO transmission system.
ERROR SKS OPEN 4	<ul style="list-style-type: none"> – Closing edge safety device 4 is faulty in the OPEN direction → (X20) Plug-in RADIO transmission system channel 2 	<ul style="list-style-type: none"> – Check closing edge safety device. – Check the RADIO transmission system.
ERROR STOP 4	<ul style="list-style-type: none"> – Safety circuit 4 is interrupted. → (X20) Plug-in RADIO transmission system channel 2 	<ul style="list-style-type: none"> – Check the safety circuit. – Check the RADIO transmission system.
ERROR SKS-TEST	<ul style="list-style-type: none"> – Testing of attached airwave bar was unsuccessful. – Test of RADIO transmission systems 1 – 4 failed. 	<ul style="list-style-type: none"> – Check the PS pressure switch, spiral cable and rubber profile. – Check the PS POINT setting. – Check the RADIO transmission system. – Check whether the right relay MOD was selected for the transmission system. → "G. Functions for external accessories" on page 34
ERROR LIGHT BAR	<ul style="list-style-type: none"> – The installed photocell indicates a permanent fault. → (X4 / 1-4) 	<ul style="list-style-type: none"> – Check photocell (function and alignment). – Check cabling.
ERROR LIGHT BAR 2	<ul style="list-style-type: none"> – The installed photocell indicates a permanent fault. → (X4 / 9+10) input 1 	<ul style="list-style-type: none"> – Check photocell (function and alignment). – Check cabling.
ERROR LB TEST	<ul style="list-style-type: none"> – Test of two-wire photocell failed. 	<ul style="list-style-type: none"> – Check photocell (function and alignment). – Check cabling.
ERROR STOP-TEST	<ul style="list-style-type: none"> – Test of wicket door switch (8.2 kΩ) failed. → Input 2 	<ul style="list-style-type: none"> – Check wicket door switch.
ERROR TRAPIN	<ul style="list-style-type: none"> – Draw-in protection test (additional module) failed. → Relay MOD21 	<ul style="list-style-type: none"> – Check photocell (function and alignment). – Check cabling.
ERROR CYLINDER	<ul style="list-style-type: none"> – The monitoring limit switch for the lock system for threshold-less wicket doors has failed to trigger within 10 seconds of an OPEN command being given. 	<ul style="list-style-type: none"> – Check limit switch of cylinder.
ERROR MSBUS	<ul style="list-style-type: none"> – Communication between the control and the MS BUS module attached is interrupted. 	<ul style="list-style-type: none"> – Check the cable and socket connections and replace, if necessary.

After rectifying the cause of the error, the power supply to the control must be turned off once and/or the control must be restarted (> INPUT menu > parameter RESTART > ON) in the event of the following errors:

- ERROR DIRECTION
- ERROR RUNTIME
- TERM SWITCH FAIL

11.2 Error message via LED indicator

LED H4 (green, main circuit board)

Fault / error message	LED indicator	Remarks
No operating voltage	Off	No power supply present.

LED H6 (red, main circuit board)

Fault / error message	LED indicator	Remarks
SAFETY CIRC.	Flashes 1 x	Safety circuit is interrupted. – Check safety circuit, localise interruption and rectify problem.
ERROR AWG	Flashes 2x	Signal transmission between absolute value encoder and control interrupted and/or broken down. – Check the cable and socket connections and replace, if necessary.
TERM SWITCH FAIL	Flashes 3 x	The door has travelled beyond the programmed end position area or the end positions have not yet been programmed. – First, programme the end positions. – Move the door/gate back into the programmed area using the emergency operation facility.
ERROR DIRECTION	Flashes 4x	The rotating field present is not a clockwise rotating field. – Check the rotating field and change the direction, if necessary. → "7.1 Checking the direction of rotation/direction of travel"
ERROR REVOLUTION	Flashes 5x	The power monitoring has been triggered. – Check the door for any mechanical impairment or damage.
ERROR RUNTIME	Flashes 6x	The programmed running time has been exceeded. – Check the path of the door and the running time. – Re-programme the running time, if necessary.
ERROR MSBUS	Flashes 9x	Communication error between the control and the installed MS BUS end device. – Check the cable and socket connections and replace, if necessary.
ERROR SKS	Continuous light Travel only possible in deadman mode	Closing edge safety device faulty in OPENING or CLOSING direction. – Check the closing edge safety device and the spiral cable and, if necessary, Check the RADIO transmission system.
ERROR LIGHT BAR	Continuous light Travel in CLOSING direction only possible in deadman mode	The installed photocell indicates a permanent fault. – Check photocell (function and alignment). – Check cabling.

12. Technical data

12.1 Mechanical and electrical data

Housing dimensions:	215 x 275 x 190 mm
Installation:	Fix vertically to the wall at a minimum height of 1,100 mm
Power supply via	
L1, L2, L3, N, PE:	400V/3~ , 50/60Hz 230V/3~ , 50/60Hz
L1, N, PE:	230V/1~ , 50/60Hz
	Power input max. 2,200W for power supply 400V/3~
Fuse protection:	10 A K type
Internal consumption of the control:	max. 750 mA
Control voltage:	24 V DC, max. 500 mA; protected by self-resetting fuse for external sensor systems.
Control inputs:	24 V DC all inputs must be connected so that they are potential-free. Minimum signal duration for input control command > 100 ms
Control outputs:	24 V DC, max. 500 mA
RS485 A and B	Only for electronic limit switches RS485 level, terminated with 120 Ω
Safety circuit / Emergency stop:	All input connections MUST be potential-free; if the safety circuit is interrupted, no further electrically powered movement of the operator is possible, not even in deadman mode
Closing edge safety device input (performance level C):	Performance level C for electrical closing edge safety devices with 8.2 kΩ terminating resistor and for dynamic optical systems
Photocell (performance level D):	If the photocell is used as a D performance level protection system, it must be checked at regular intervals – at least every 6 months – to ensure that the system is working properly. Marantec two-wire photocells have a self-test facility, so this requirement does not apply in this case.
Display (LCD):	Only an original Marantec LCD monitor may be used.

Relay outputs:	If inductive loads are connected (e.g. further relays or brakes), these must be equipped with suitable interference suppression (such as recovery diode, varistors or RC circuits). Potential-free normally open contact; min. 10 mA; max. 230 V AC / 4A. <i>Once contacts have been used for power circuits, they can no longer be used for extra-low current circuits.</i>
Temperature range:	Operation: -10°C ... +45°C Storage: -25°C ... +70°C
Air humidity:	Up to 80% with no condensation
Vibrations:	Low-vibration mounting, e.g. on a masonry wall
Protection grade	IP 65
Weight	approx. 1.8 kg

12.2 Functional safety category and performance level according to EN ISO 13849-1

Function	Implementation	MTTF _D Electronics	MTTF _D Complete, with output contactor (1)	DC _{avg}	Category	Performance level
Emergency Stop	Input terminal X3, X6, X7, X11 Interrupts voltage supply to the output relays and main contactor, independently of the CPU. Signal received by CPU.	1175 years	191 years	85.3%	3	GB
Stop circuit	Input terminal X3, X7 Interrupts the power supply to the main contactor. Signal to CPU.	1175 years	191 years	-	B	B
End position recognised by absolute value encoder (2)	Input terminal X11 For determining the position, and for end position detection. Safety through checking plausibility of drive commands with signals received.	1062 years	188 years	85.6%	2	GB
End position recognised by end position switch (2)	Input terminal X15 Safeguarded through excess travel stop. Inputs are evaluated by the CPU.	1248 years	193 years	85.5%	2	GB
Photocell evaluation	Input terminal X4 Impulse evaluation through CPU. Faults are detected through plausibility check in the CPU. The frequency must lie between 130 and 190 Hz. The function is tested by switching on the supply voltage (T117, IC111) of the photocell before every run and every two minutes in standby. If activated in the CLOSING direction, the door stops or reverses.	1000 years	186 years	85.7%	2	GB

DC_{AVG}
MTTF_D

Average diagnostic coverage
Mean time to dangerous failure

13. Maintenance

The CS 310 control is maintenance-free.



DANGER!

Life-threatening danger due to electric shock!

⚠ The control unit or door system **MUST** be disconnected from the electricity supply before carrying out any electrical work! Take measures to ensure that the power supply remains disconnected for the duration of the work.

The following points must be taken into account when carrying out maintenance on the door system:

- Maintenance must only be carried out by authorised persons.
- Directive ASR A1.7 must be complied with.
- Worn or faulty parts must be replaced.
- Only approved parts may be installed.
- All maintenance work must be documented.
- Replaced faulty parts must be disposed of properly in accordance with the materials they contain and local regulations.

14. EC Declaration of conformity

EN

We hereby declare that the product described below:

CS 310 Door Control

is in conformity with all essential requirements of the Machinery Directive 2006/42/EC.

In addition, the logic unit is in conformity with all the provisions of the

- Electromagnetic Compatibility Directive (2014/30/EC)
- Low Voltage Directive (2014/35/EC).

The following standards were applied:

EN 60204-1

Safety of machinery, electrical equipment of machines; Part 1: General requirements

EN ISO 12100

Safety of machinery – general principles for design - risk assessment and risk reduction

DIN EN 12453

Safety in use of power operated doors - Requirements

prEN 12453: 2014

Safety in use of power operated doors
(exclusively for items 1.3.7 and 1.4.3 of Annex I of the Machinery Directive)

DIN EN 61000-6-2

Electromagnetic compatibility (EMC) - Part 6-2: Generic standards - Immunity for industrial environments

DIN EN 61000-6-3

Electromagnetic compatibility (EMC) - Part 6-3: Generic standards - Emission - standard for residential, commercial and light-industrial environments

DIN EN 60335-1

Household and similar electrical appliances - Safety – Part 1: General requirements

DIN EN 60335-2-103

Household and similar electrical appliances – Safety – Part 2-103: Particular requirements for drives for gates, doors and windows

EN ISO 13849-1

Safety of machinery – Safety-related parts of control systems – Part 1: General principles for design

The relevant technical documentation is compiled in accordance with Annex VII (B) of the EC Machinery Directive 2006/42/EC. We undertake to transmit, in response to a reasoned request by the market surveillance authorities, this information in electronic form within a reasonable term.

EC type examination certificate No. 4420513133301

TÜV NORD CERT GmbH (NB 0044)

Langemarckstrasse 20

D - 45141 Essen, Germany

Person authorised to compile the relevant technical documentation:

Marantec GmbH & Co. KG, Remser Brook 11,
D-33428 Marienfeld

The logic unit must not be put into service until the machinery into which the logic unit is to be incorporated has been declared in conformity with the provisions of the Machinery Directive 2006/42/EC.

Place / Date:

Marienfeld, 02.01.2017

Manufacturer's signature



Michael Hörmann

Position of signatory

Management

15. Appendix

15.1 Overview of connections

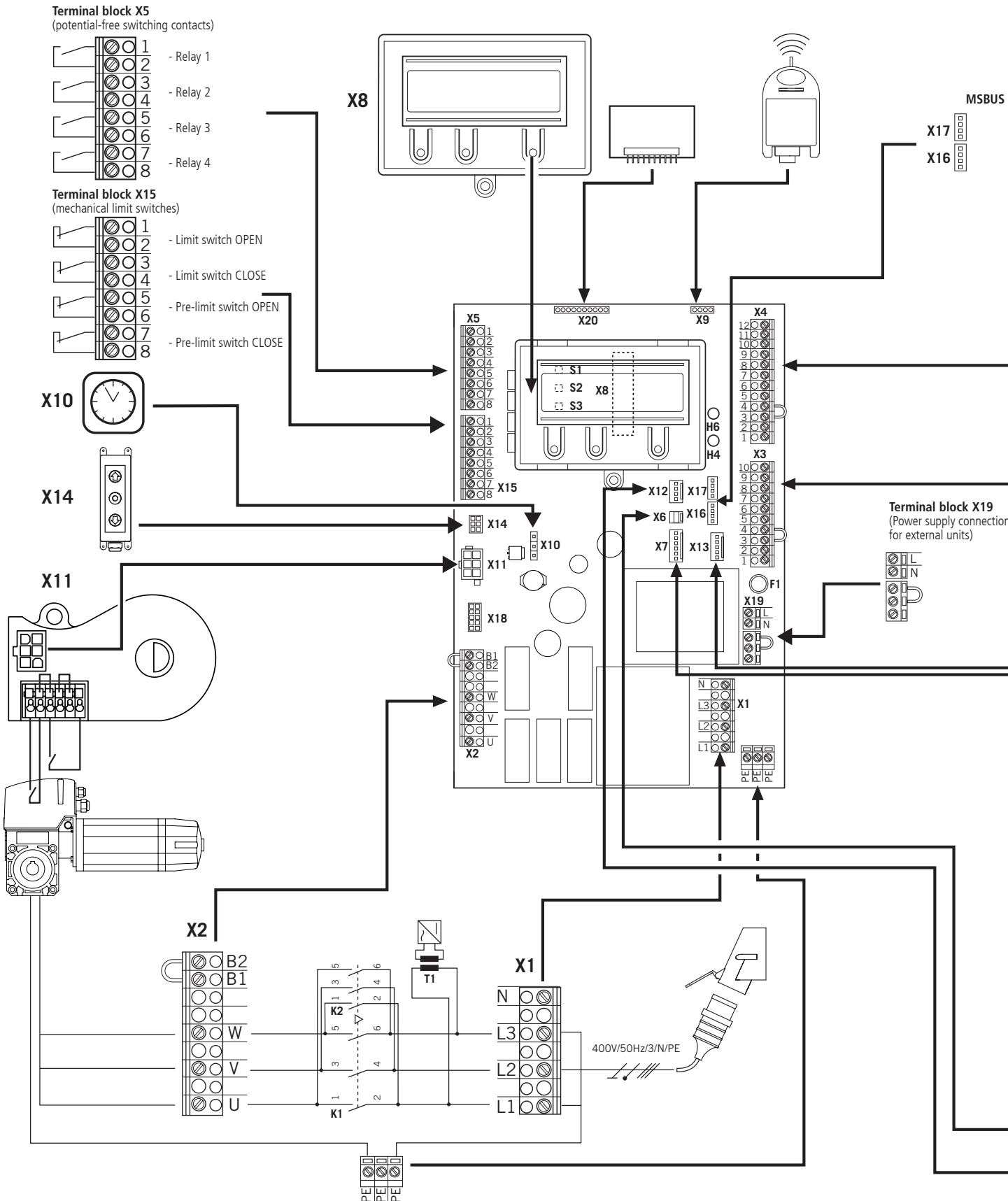

Terminal block X4
(for opto-electronic closing edge safety device)

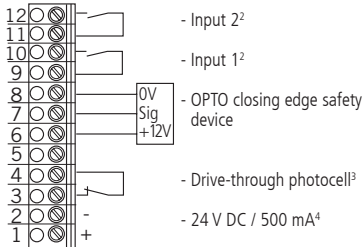

Terminal block X4
(for 8.2 kΩ closing edge safety device)

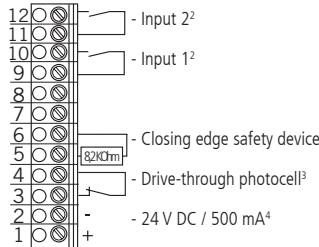

Terminal block X4
(for pneumatic closing edge safety device – pressure sensor test)

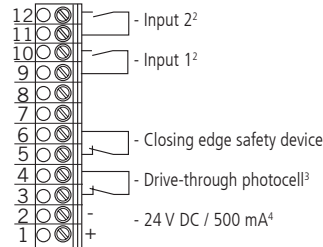

Terminal block X4
for three-wire photocell PNP or NPN

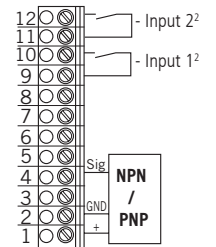

X4

X3

Terminal block X3
(assignment)

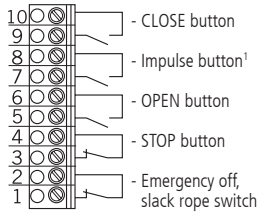

OPEN / STOP / CLOSE buttons
(6-lead solution)

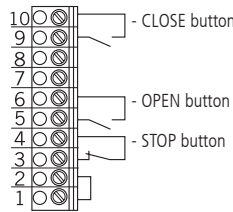

OPEN / STOP / CLOSE buttons
(4-lead solution)

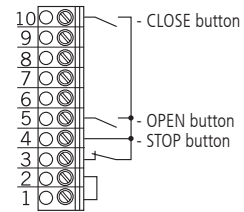

Impulse button
(sequence control)

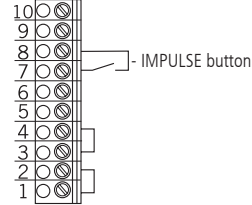

Key switch OPEN / CLOSE

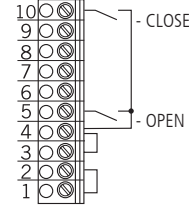

X13

Buttons on CS housing

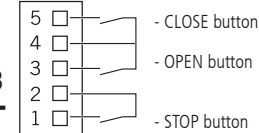

X7

KDT switch

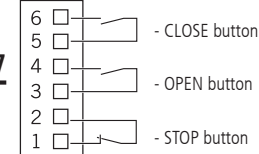

X6

Internal ON/OFF switch

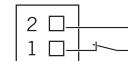

X12

External radio

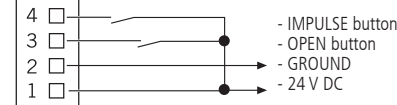

- 1 sequence control
- 2 button or 2-way switch
- 3 effective in down direction
- 4 for external switching devices (connection to terminals 1 and 2)

ws: white
gr: green
br: brown

Appendix

15.2 Measuring points, safety circuit

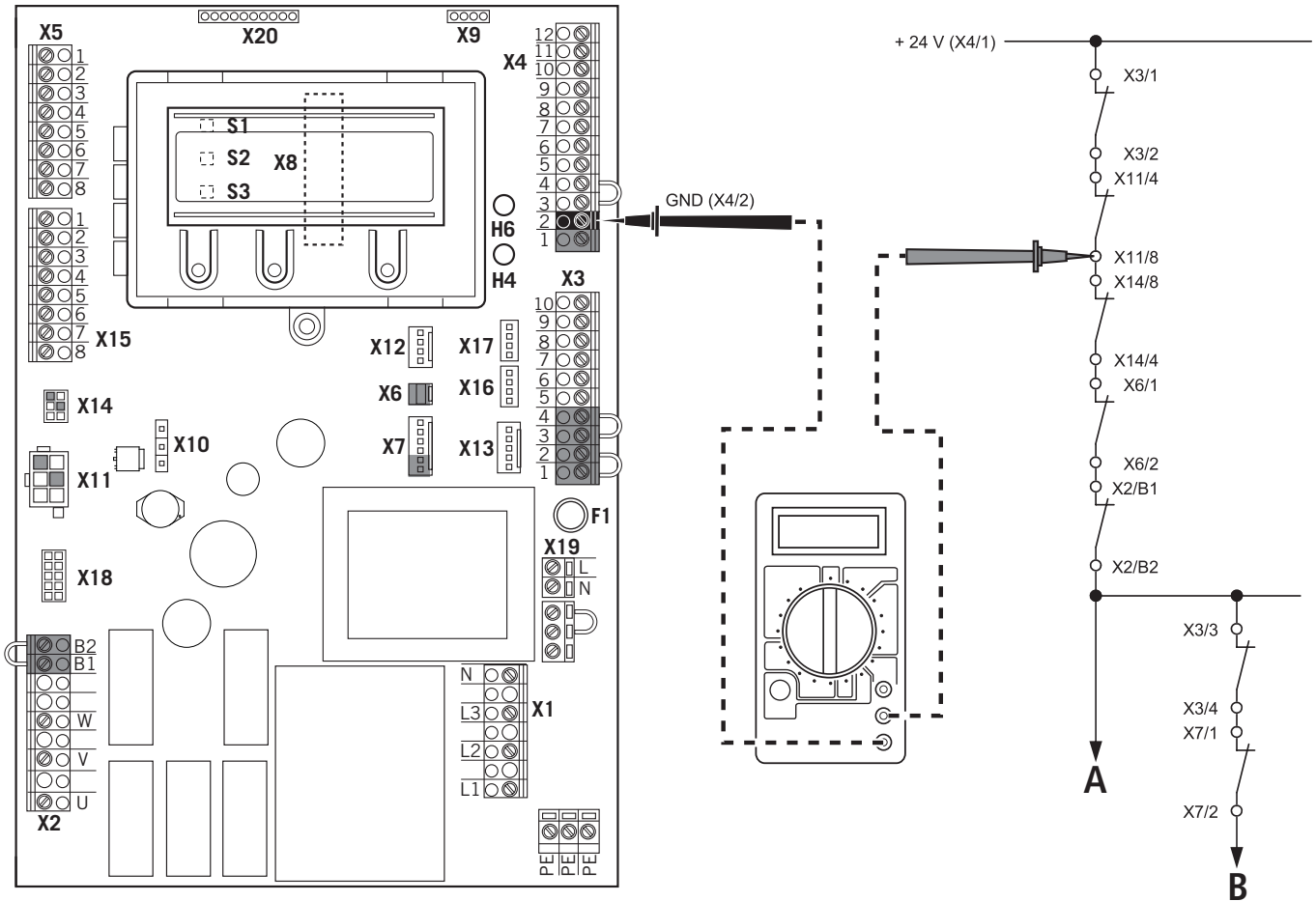

NOTICE:

The measurement range must be set for 24 V-DC.

- A Emergency Stop
- B Stop

🔍 Measure at all measuring points on the diagram in order to locate the interruption.

#1700026614
#159497