



[www.max.us.com](http://www.max.us.com)

CONFORMS TO UL STD 325  
UL CLASS - III, IV

CERTIFIED TO CAN/CSA STD  
C22.2 NO. 247



**Commercial/Industrial  
UL 325 Class III & IV ONLY  
FAST SLIDE - Up to 18 in/sec  
Brushless DC Slide Gate Operator**

NOT intended for residential use

Made in USA



Intertek  
4009963

**MAX F18**

Installation and Owners Manual



# TABLE OF CONTENTS

MAX F18 Specifications	2
Important Safety Information	2
UL 325 Model Classifications	3
UL 325 Required Entrapment Protection	3
UL 325 Compliant Installation Requirements	4
Intended Use of Slide Gate Operator	5

## INSTALLATION

Operator in Front Mounting Position (Standard)	6
Connect Chain to Gate - Front Mounting Position	7
Operator in Rear Mounting Position (Alternate)	8
Connect Chain to Gate - Rear Mounting Position	9
Dual Gate Operators - Front Mounting Position	10
Optional Remote Power Supply Kit - MAX Magic Box	11
Solar - Optional	12
Install Warning Signs	13
Photocell Safety and Entrapment Protection	14
Sensing Edge Safety and Entrapment Protection	15
In-Ground Loops	16

## WIRING OPERATOR

Gate Operator System Overview	17-18
High Voltage Input AC Power	19
Low Voltage Remote Power Supply Kit - Optional	20
Solar Power Connection - Optional	21
Secondary Operator to Matrix 1	22
Turn ON / OFF Operator Power	23

## MATRIX 1

Matrix 1 Overview	24
Wiring Overview	25
Primary Gate - Open Left / Open Right	26
Close Timer	26
Selectable Gate Speed Control	26
Battery Back-Up Mode	26
Anti-Tailgate	27
Single Pass Anti-Tailgate	27
Radio Receiver	28
Radio Safety Pause	28
Gate in Motion Alarms	28
OBD Port Black Box	28
Maglock	29
Loop Detectors	29
In-Ground Loop Connection	29
ID Plug	30
Gate Tamper	30
UL Entrapment LEDs	30
Emergency Vehicle / Max Open Inputs	30
Gate Disable	31
Partial Open	31
UL Alarm Warning Light Input	31
Gate Status Monitoring	32
OPEN / STOP / CLOSE Connection	32
CLOSING Photocell Connection	32
Motor Motion LEDs	32
Gate Operators Communication LEDs	33
24V Power for Matrix 1	33
Battery in Use LED	33
Gate Shut-Off Switch	34
External Open/Close Key Switch - Optional	35

## ADJUSTMENTS

Open and Close Limits	36
Reverse Sensor (ERD)	37

## MAINTENANCE

Primary/Single and Secondary Operator Wiring Schematics	38-39
Qualified gate operator technician	40
End user/Home owner	40
Electronic Gate OPEN / CLOSE	41
Mechanical Gate Release (Manual Release)	41
Audible Alarm	42
Replacement Parts List	43
Warranty	44

## OPTIONS/UNIQUE FEATURES

Gate Tamper Feature	45
Magnetic Dynamic Brake System	46
Gear Reducer	46
Partial Open Feature	47
Gate Disable Feature	48
Event History Download	48
MAX Chain Release Mechanism - Optional	49

© 2015 Maximum Controls LLC.

All rights reserved. No part of this manual may be reproduced in any means: graphics, electronics or mechanical, including photocopying without the expressed written permission of the publisher. Materials components and specifications are subject to change without notice.

# MAX F18 SPECIFICATIONS

**UL 325 Class of Operation** - Class III, IV ONLY

**Gate Type** - Vehicular Slide Gate

**Max Gate Length** - 50 ft

**Max Gate Weight** - 1600 lbs Level Gate; 1000 lbs Uphill Gate - 5° Max

**Opening Time** - Selectable speed control (MAX - 18 inch per second)

**Cycles per Hour AC Power** - Continuous

**Battery Back-Up Cycles** (Batteries fully charged) - approximately 100 cycles

**NOTE:** The number of gate cycles using **ONLY** battery back-up power will vary depending on the weight of the gate, the gate length, the operating condition of the gate, temperature and the amount of charge the batteries have at the beginning of the battery power only operation.

**Input AC Power** - Switchable: 115VAC or 230VAC single phase

**Motor** - 1 HP 24VDC Brushless (6 million cycles)

**Chain Size** - #40

**Operating Temperature:** -4°F to 158°F (-20°C to 70°C)

**Entrapment Protection:**

- UL 325 Type A Inherent (ERD sensor)
- Input for UL 325 Type B1 (photocell) and B2 (sensing edge)

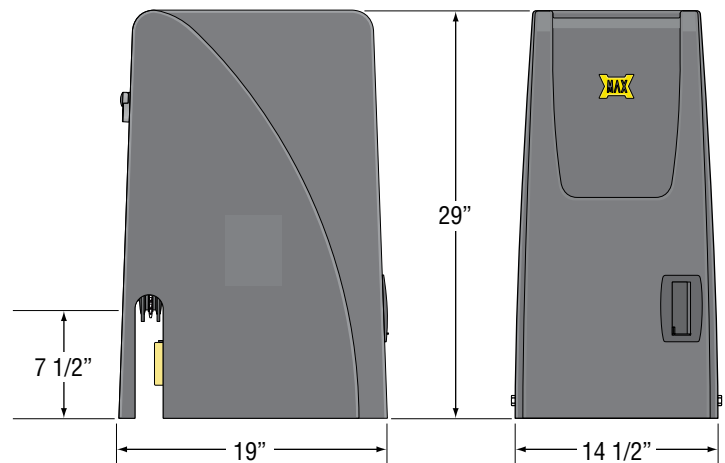

## IMPORTANT SAFETY INFORMATION

**WARNING – To reduce the risk of injury or death:**

1. READ AND FOLLOW ALL INSTRUCTIONS.
2. Never let children operate or play with gate controls. Keep the remote control away from children.
3. Always keep people and objects away from the gate. NO ONE SHOULD CROSS THE PATH OF THE MOVING GATE.
4. Test the gate operator monthly. The gate **MUST** reverse on contact with a rigid object or stop when an object activates the non-contact sensors. After adjusting the force or the limit of travel, retest the gate operator. Failure to adjust and retest the gate operator properly can increase the risk of injury or death.
5. Use the emergency release only when the gate is not moving.
6. KEEP GATES PROPERLY MAINTAINED. Read the owner's manual. Have a qualified service person make repairs to gate hardware.
7. The entrance is for vehicles only. Pedestrians must use separate entrance.
8. SAVE THESE INSTRUCTIONS

# UL 325 MODEL CLASSIFICATIONS



**CLASS I**

**Residential Vehicular Gate Operator** - A vehicular gate operator (opener or system) intended for use in a home of one to four single family dwellings, or a garage or parking area associated therewith.

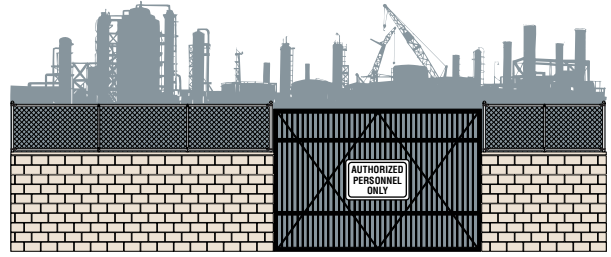

**CLASS III**

**Industrial/Limited Access Vehicular Gate Operator** - A vehicular gate operator (opener or system) intended for uses in an industrial location, loading dock area or other location not intended to service the general public.

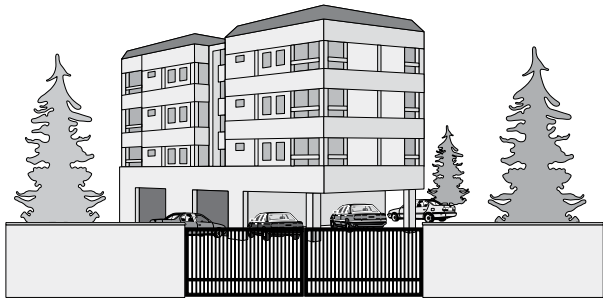

**CLASS II**

**Commercial/General Access Vehicular Gate Operator** - A vehicular gate operator (opener or system) intended for use in a commercial location or building such as a multi-family housing unit (five or more single family units) hotel, garages, retail store or other building servicing the general public.

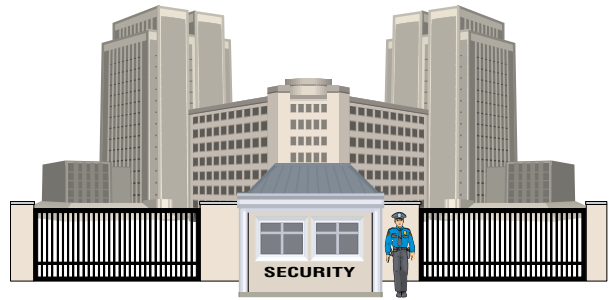

**CLASS IV**

**Restricted Access Vehicular Gate Operator** - A vehicular gate operator (opener or system) intended for use in a guarded industrial location or buildings such as airport security area or other restricted access locations not servicing the general public, in which unauthorized access is prevented via supervision by security personnel.

## UL 325 REQUIRED ENTRAPMENT PROTECTION

Gate Type	Protection Type	Class I & II	Class III	Class IV
Slide Gate	Primary	A	A, B1, B2	A, B1, B2, D
	Secondary	B1, B2, D	A, B1, B2, D, E	A, B1, B2, D, E

The same type of device shall not be utilized for both the primary and the secondary entrapment protection means. Use of a single device to cover both the opening and closing directions is in accordance with the requirement; however, a single device is not required to cover both directions. A combination of one Type B1 for one direction and one Type B2 for the other direction is the equivalent of one device for the purpose of complying with the requirements of either the primary or secondary entrapment protection areas.

**A** - Inherent entrapment protection system.

**B1** - Provision for connection of a non-contact sensor (photoelectric sensor or the equivalent).

**B2** - Provision for connection of a contact sensor (edge device or the equivalent).

**C** - Inherent adjustable clutch or pressure relief device.

**D** - Provision for connection of an actuating device requiring continuous pressure to maintain opening or closing motion of the gate.

**E** - An audio alarm.

# UL 325 COMPLIANT INSTALLATION REQUIREMENTS

- A** Install the gate operator only when:
- 1 The operator is appropriate for the construction of the gate and the usage Class of the gate,
  - 2 All openings of a horizontal slide gate are guarded or screened from the bottom of the gate to a minimum of 6 feet (1.83 m) above the ground to prevent a 2-1/4 inch (57.2 mm) diameter sphere from passing through the openings anywhere in the gate, and in that portion of the adjacent fence that the gate covers in the open position,
  - 3 All exposed pinch points are eliminated or guarded, and
  - 4 Guarding is supplied for exposed rollers.
- B** The operator is intended for installation only on gates used for vehicles. Pedestrians must be supplied with a separate access opening. The pedestrian access opening shall be designed to promote pedestrian usage. Locate the gate such that persons will not come in contact with the vehicular gate during the entire path of travel of the vehicular gate.
- C** The gate must be installed in a location so that enough clearance is supplied between the gate and adjacent structures when opening and closing to reduce the risk of entrapment. Swinging gates shall not open into public access areas.
- D** The gate must be properly installed and work freely in both directions prior to the installation of the gate operator. Do not over-tighten the operator clutch or pressure relief valve to compensate for a damaged gate.
- E** For gate operators utilizing Type D protection:
- 1 The gate operator controls must be placed so that the user has full view of the gate area when the gate is moving,
  - 2 A gate operator shall additionally be provided with a placard that is marked in letters at least 1/4-in (6.4-mm) high with the word **“WARNING”** and the following statement or the equivalent: **“Moving Gate Has Potential of Inflicting Injury or Death - Do Not Start Gate Unless Path is Clear”**.
  - 3 An automatic closing device (such as a timer, loop sensor, or similar device) shall not be employed, and
  - 4 No other activation device shall be connected.
- F** Controls intended for user activation must be located at least ten feet (10') away from any moving part of the gate and where the user is prevented from reaching over, under, around or through the gate to operate the controls. Outdoor or easily accessible controls shall have a security feature to prevent unauthorized use.
- G** The Stop and/or Reset button must be located in the line-of-sight of the gate. Activation of the reset control shall not cause the operator to start.
- H** A minimum of two (2) WARNING SIGNS shall be installed, one on each side of the gate where easily visible.
- I** For gate operators utilizing a non-contact sensor:
- 1 See instructions on the placement of non-contact sensors for each Type of application,
  - 2 Care shall be exercised to reduce the risk of nuisance tripping, such as when a vehicle, trips the sensor while the gate is still moving, and
  - 3 One or more non-contact sensors shall be located where the risk of entrapment or obstruction exists, such as the perimeter reachable by a moving gate or barrier.
- J** For a gate operator utilizing a contact sensor:
- 1 One or more contact sensors shall be located where the risk of entrapment or obstruction exists, such as at the leading edge, trailing edge, and post mounted both inside and outside of a vehicular horizontal slide gate.
  - 2 One or more contact sensors shall be located at the bottom edge of a vehicular vertical lift gate.
  - 3 One or more contact sensors shall be located at the pinch point of a vehicular vertical pivot gate.
  - 4 A hardwired contact sensor shall be located and its wiring arranged so that the communication between the sensor and the gate operator is not subjected to mechanical damage.
  - 5 A wireless device such as one that transmits radio frequency (RF) signals to the gate operator for entrapment protection functions shall be located where the transmission of the signals are not obstructed or impeded by building structures natural landscaping or similar obstruction. A wireless device shall function under the intended end-use conditions.
  - 6 One or more contact sensors shall be located on the inside and outside leading edge of a swing gate. Additionally, if the bottom edge of a swing gate is greater than 6 inches (152 mm) above the ground at any point in its arc of travel, one or more contact sensors shall be located on the bottom edge.
  - 7 One or more contact sensors shall be located at the bottom edge of a vertical barrier (arm).

# INTENDED USE OF SLIDE GATE OPERATOR

The operator is intended for use on a **VEHICULAR** slide gate **ONLY**. It is intended to be used **WITH** appropriate entrapment protection safety devices and in-ground vehicle loop detection system.

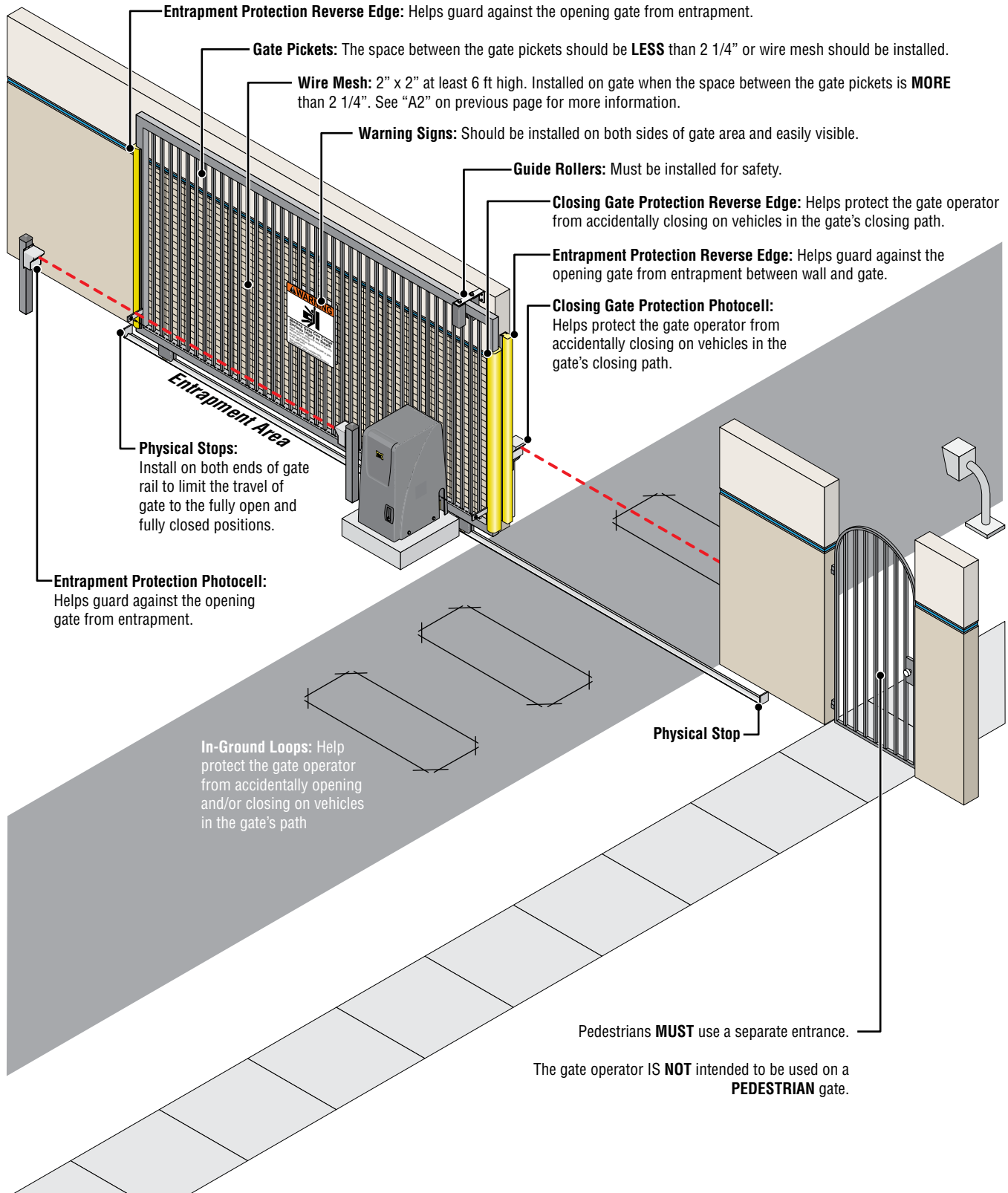

# INSTALLATION

Read and understand this entire manual before installation. Check with the local building department prior to installing this gate operator to comply with local building code requirements. The gate must be installed in a location so that enough clearance is supplied between the gate and adjacent structures when opening and closing to reduce the risk of entrapment.

## OPERATOR IN FRONT MOUNTING POSITION (STANDARD)

The gate must be properly installed and work freely in both directions prior to installation of the gate operator.

### Operator Position on Concrete Pad

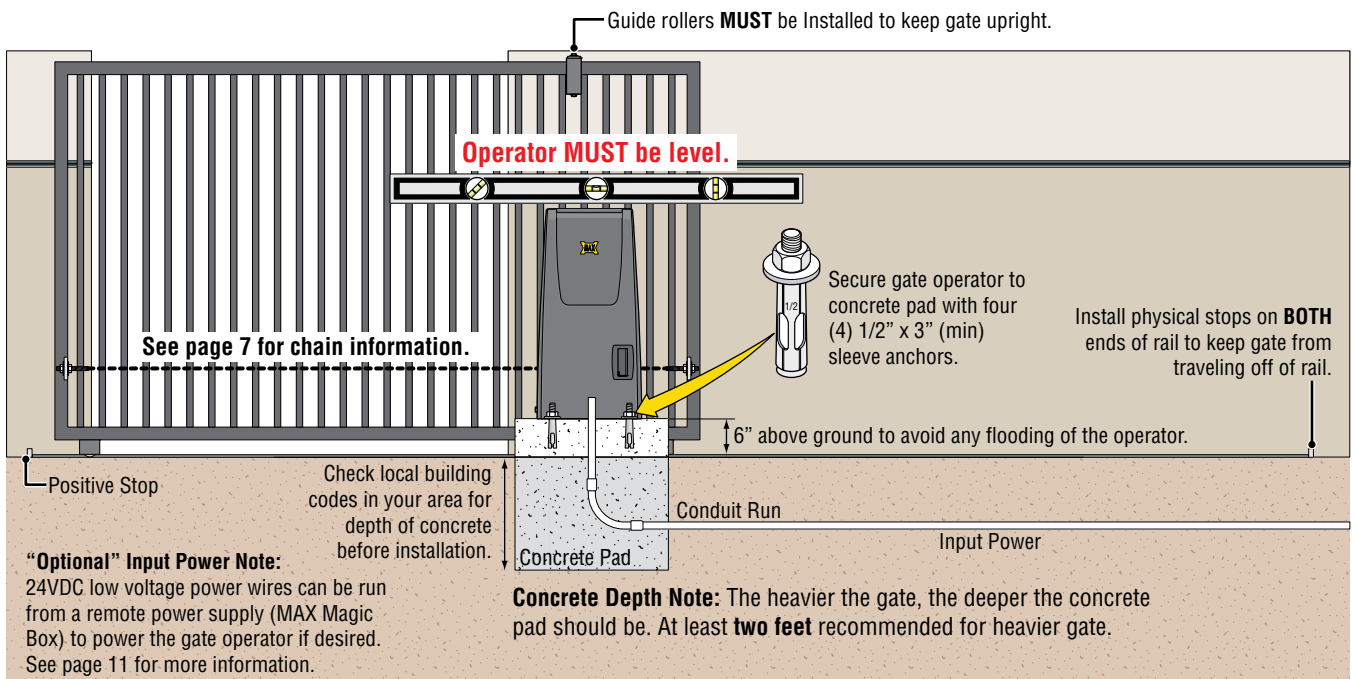
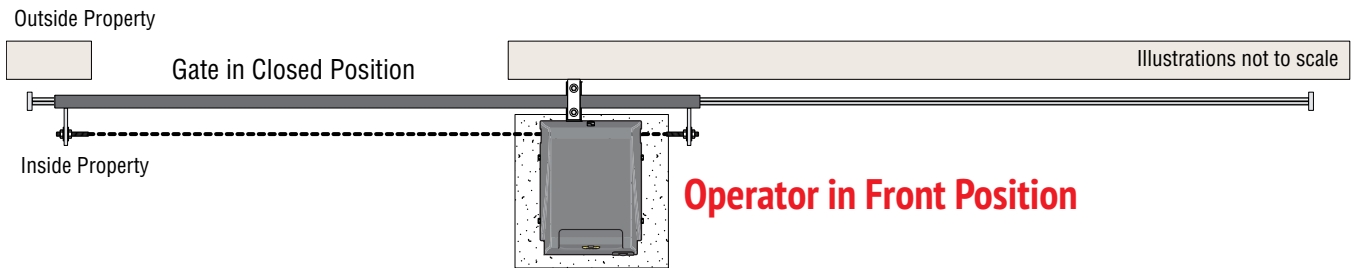
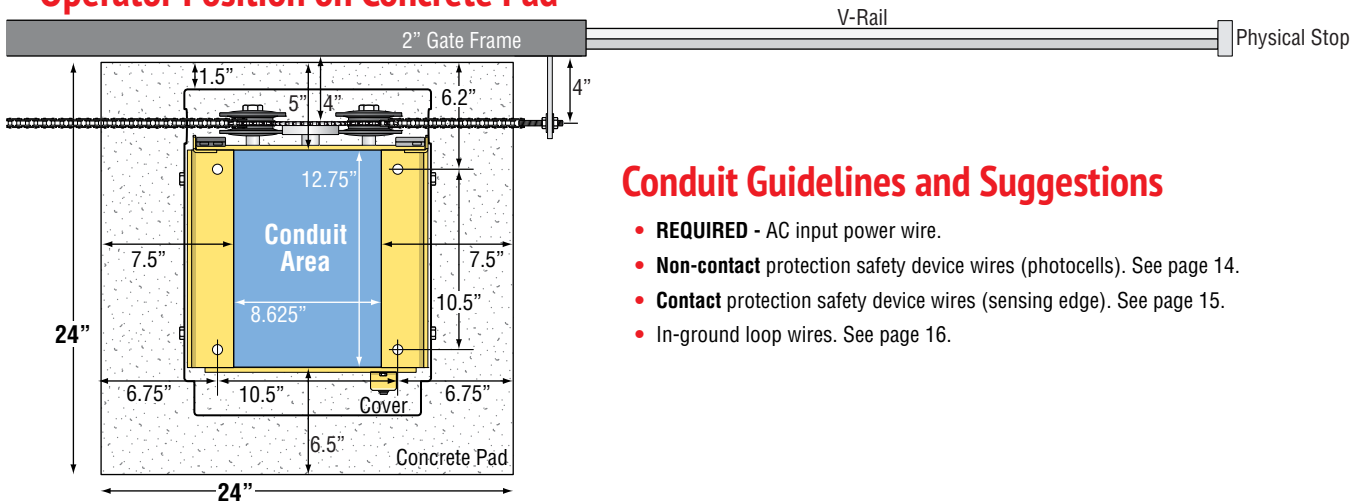

#### "Optional" Input Power Note:

24VDC low voltage power wires can be run from a remote power supply (MAX Magic Box) to power the gate operator if desired. See page 11 for more information.



# INSTALLATION

## CONNECT CHAIN TO GATE - FRONT MOUNTING POSITION

### Top View of Operator

**NOTE:** 25 ft of #40 nickel plated chain included.

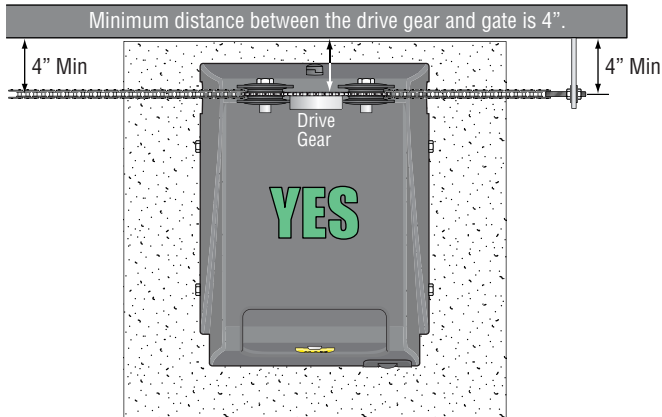

**IMPORTANT:** Operator and chain **MUST** be parallel to gate or the idler wheels could fail. Use the "Fine Tune" adjustment on the gate bracket connection bolt and make sure the chain runs through the idler wheels **without binding** on the side chain guides.

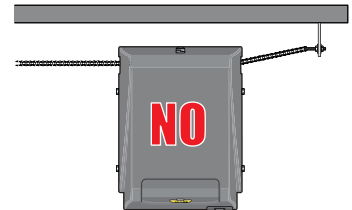
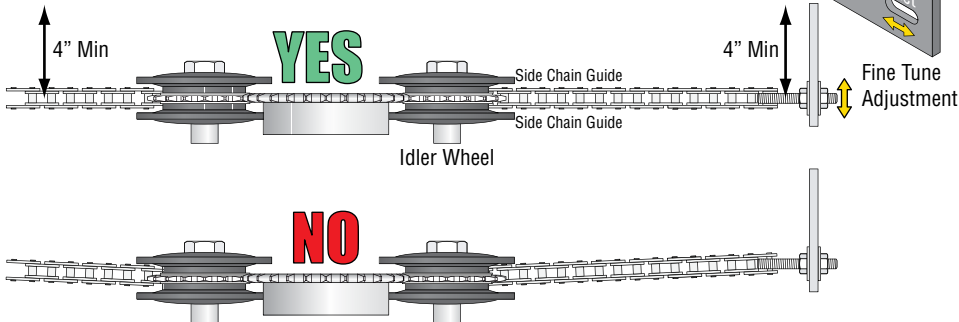

Operator is too far from gate.  
Chain is NOT parallel to gate.

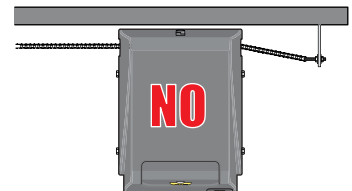

Operator is too close to gate.  
Chain is NOT parallel to gate.

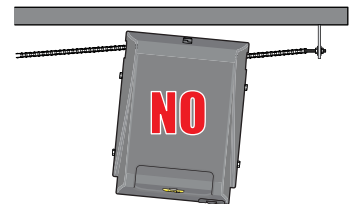

Operator is NOT parallel to gate.  
Chain is NOT parallel to gate.

### Back View of Operator

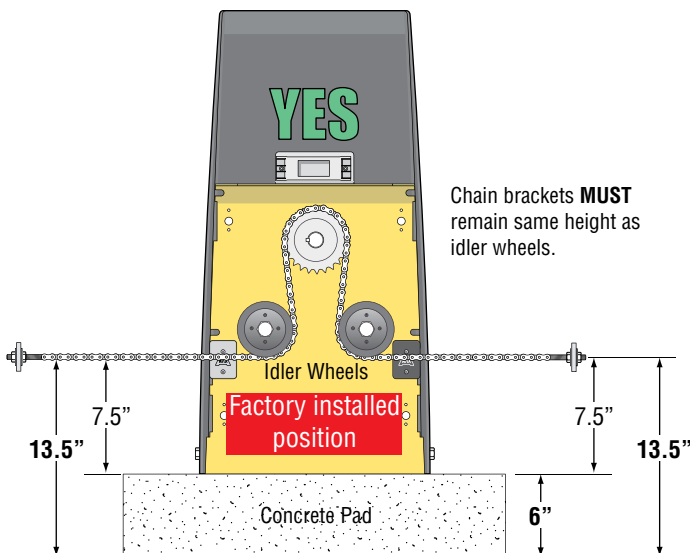

**NOTE:** The chain should sag no more than one (1) inch per 10 feet of travel. Do not over tighten the chain.

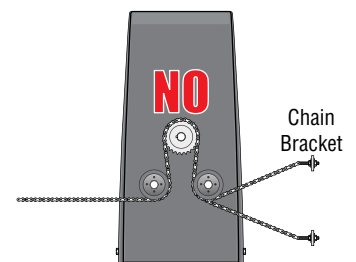

DO NOT mount chain bracket too high or too low on gate.

# INSTALLATION

## OPERATOR IN REAR MOUNTING POSITION (ALTERNATE)

The gate must be properly installed and work freely in both directions prior to the installation of the gate operator. The chain is not visible when looking from outside of the property.

### Operator Position on Concrete Pad

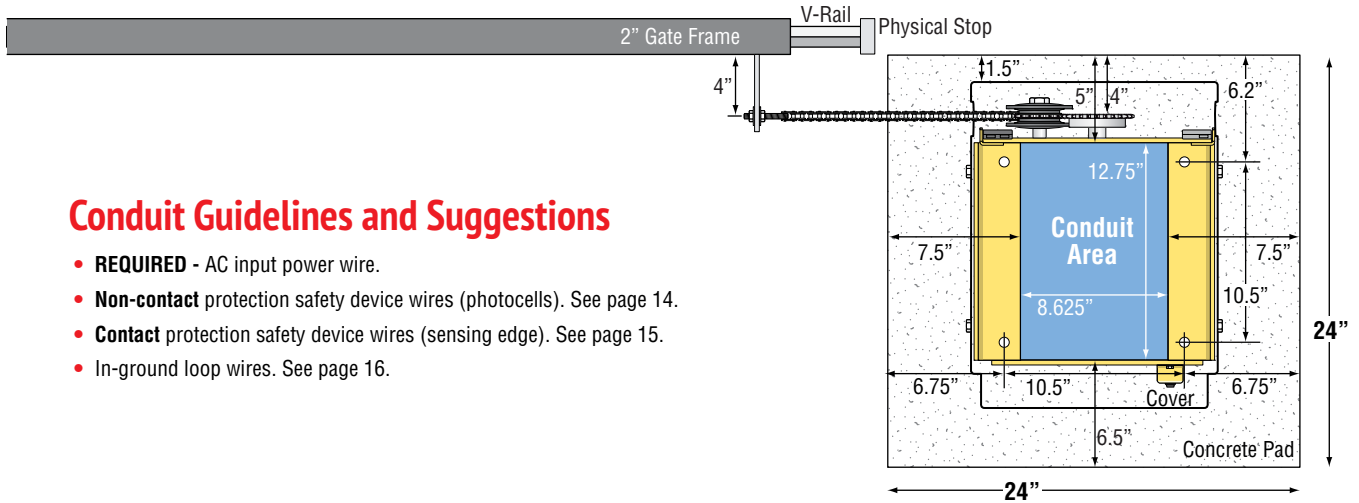

### Conduit Guidelines and Suggestions

- **REQUIRED** - AC input power wire.
- **Non-contact** protection safety device wires (photocells). See page 14.
- **Contact** protection safety device wires (sensing edge). See page 15.
- In-ground loop wires. See page 16.

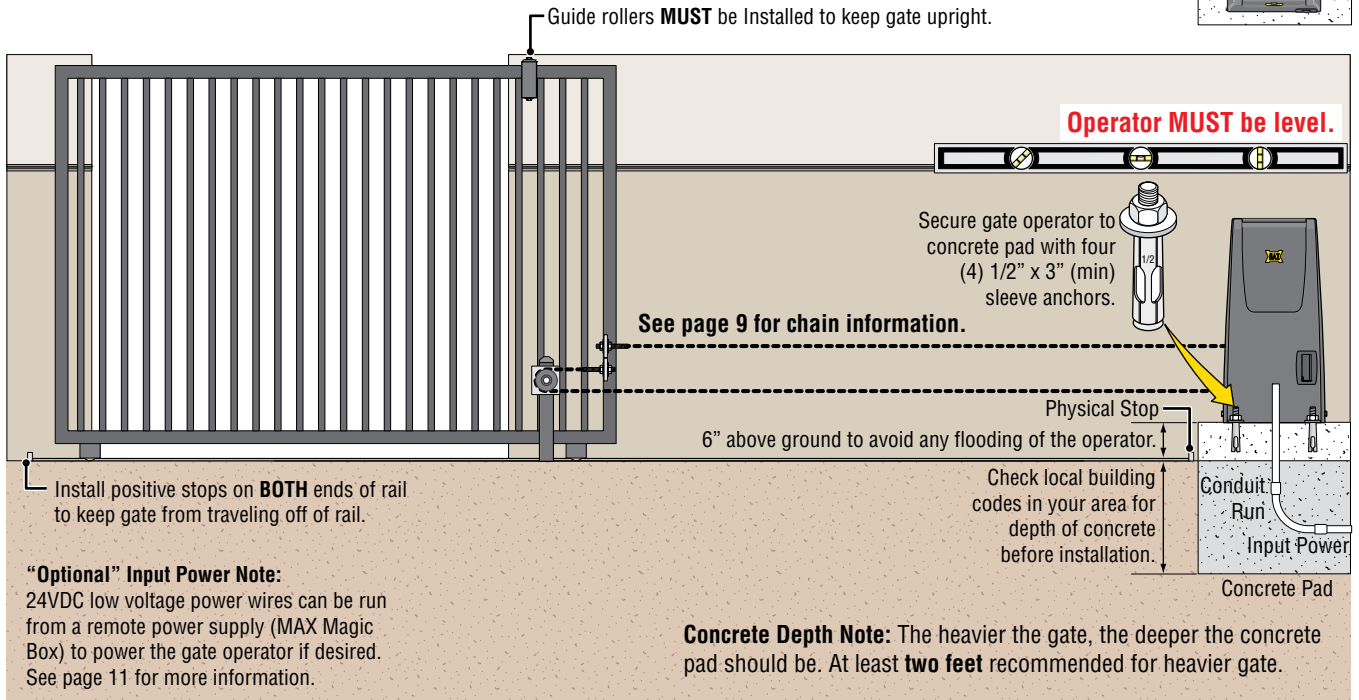
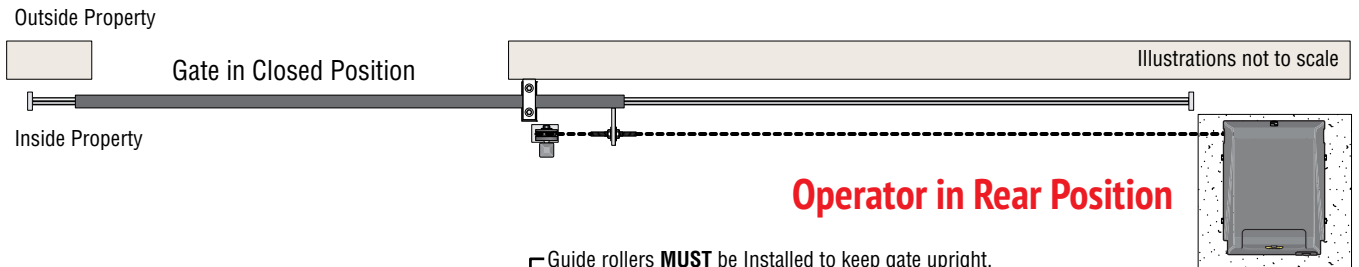

# INSTALLATION

## CONNECT CHAIN TO GATE - REAR MOUNTING POSITION

**NOTE:** 25 ft of #40 nickel plated chain included.

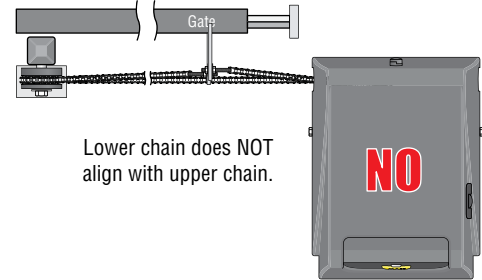
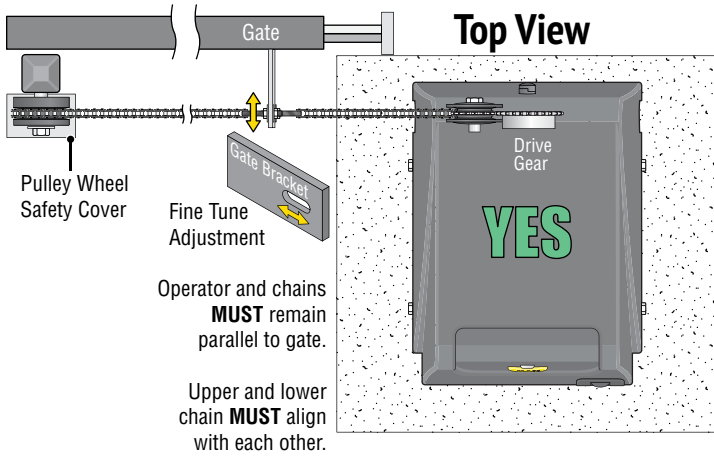

**IMPORTANT:** Make sure that chain is **parallel** to gate. Incorrect installation will cause excessive noise, idler and pulley wheel wear and chain stretching.

Limit sensors will need to be relocated to align with rear chain configuration. See page 36 for more information.

**NOTE:** The chain should sag no more than one (1) inch per 10 feet of travel. **Do not over tighten the chain.**

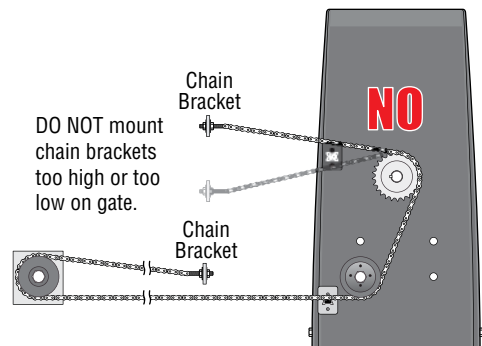
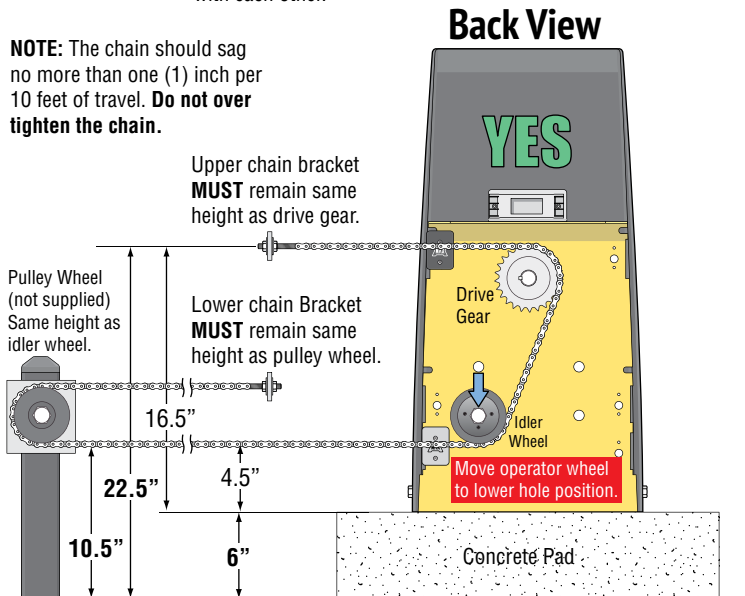

## Modify Cover for Rear Mounting Position

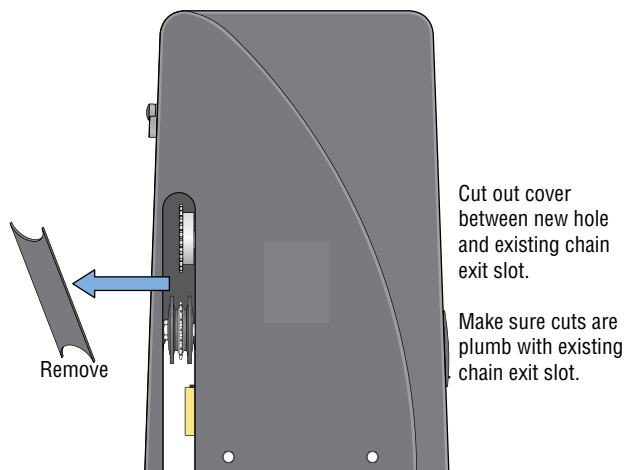
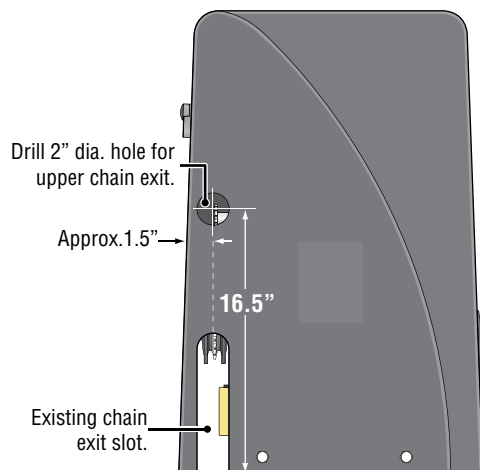

# INSTALLATION

## DUAL GATE OPERATORS - FRONT MOUNTING POSITION

The gates must be properly installed and work freely in both directions prior to the installation of the dual gate operators. See "Operator in Front Mounting Position" on page 6 for operator positions.

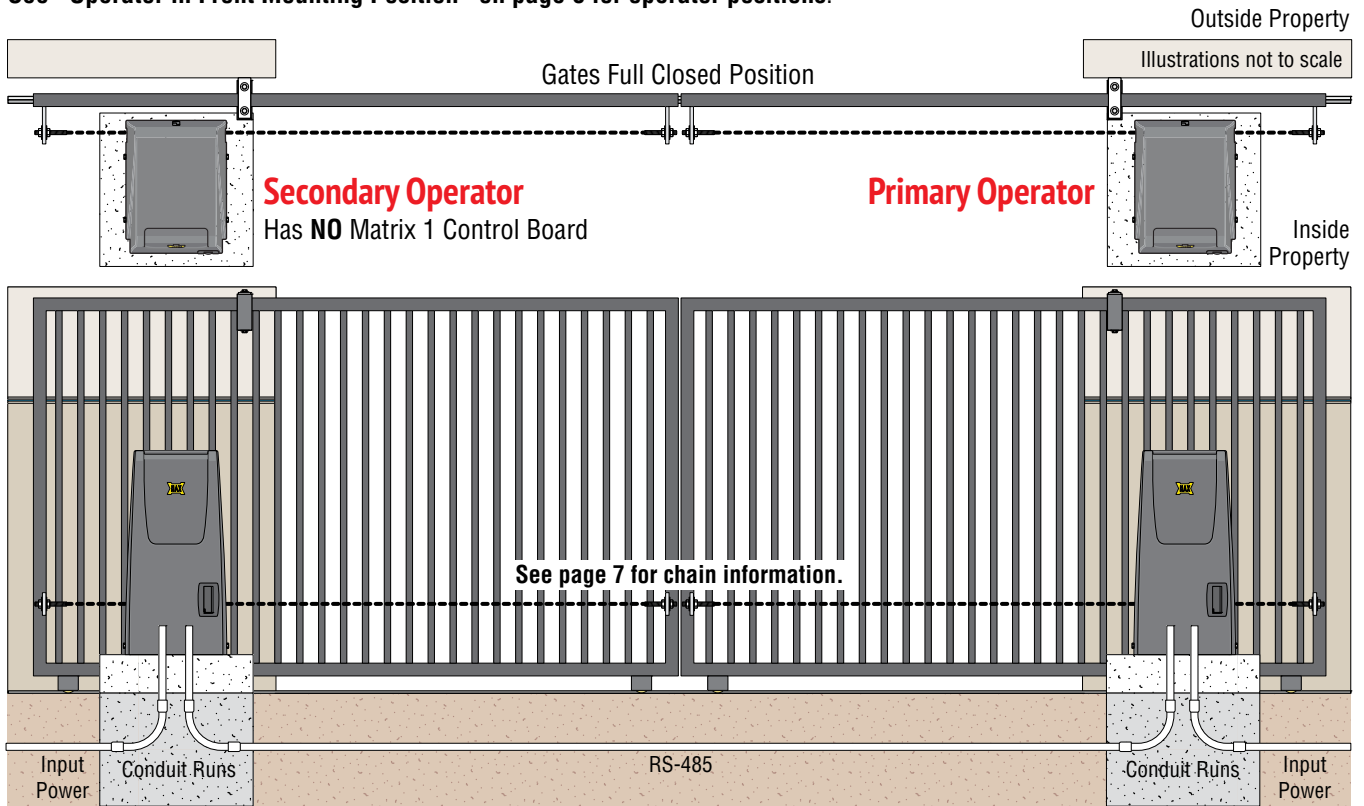

### Conduit Guidelines and Suggestions

- **REQUIRED** - AC input power wire to **EACH** gate operator.
- **REQUIRED** - RS-485 wires **CONNECT** operators together.
- **Non-contact** (photocells) secondary entrapment protection safety device wires to **EACH** Corresponding **OPERATOR**. See below & page 14.
- **Contact** (sensing edge) entrapment protection safety device wires to **EACH** Corresponding **OPERATOR**. See below & page 15.
- **CLOSING** cycle non-contact (photocells) safety protection device wires to **MATRIX 1** See below & page 14.
- In-ground loop wires to **MATRIX 1**. See page 16.
- Optional external OPEN/CLOSE key switch wires from **EACH OPERATOR** to key switch. See page 35.

## Dual Gate Operators CONTACT and NON-CONTACT protection safety device Positions and Connections

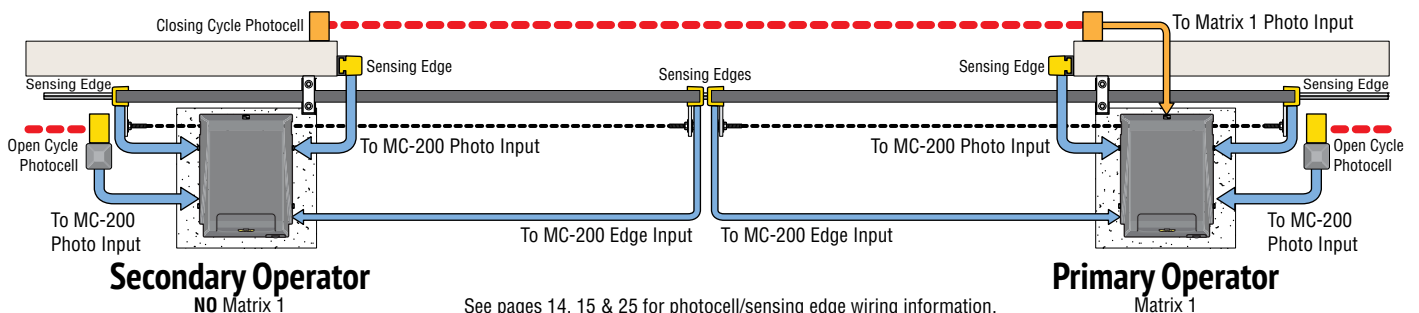

See pages 14, 15 & 25 for photocell/sensing edge wiring information.

# INSTALLATION

## OPTIONAL REMOTE POWER SUPPLY KIT - MAX MAGIC BOX

A remote power supply is for installations where it is too costly or difficult to trench a 115/230 VAC power line to the operator but instead run a low voltage power line to the operator. A **MAX Magic Box Kit** (sold separately) is required to remotely install a **MAX Toroid 15 Amp Box**.

Install **MAX Magic Box** near the 115 VAC or 230 VAC input AC power source. See tables for MAX distance away from operator. See page 20 for **MAX Magic Box** wiring instructions.

**NOTE:** A **MAX Magic Box** kit is required for **EACH** gate operator when using dual gate operators.

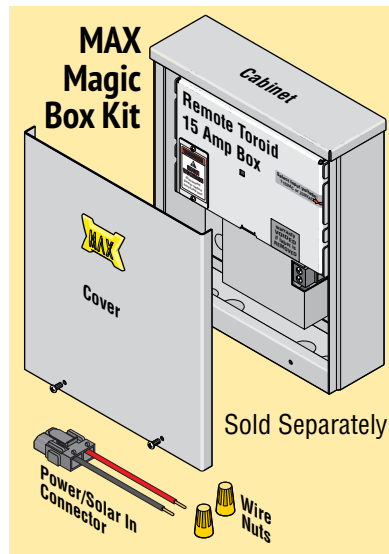
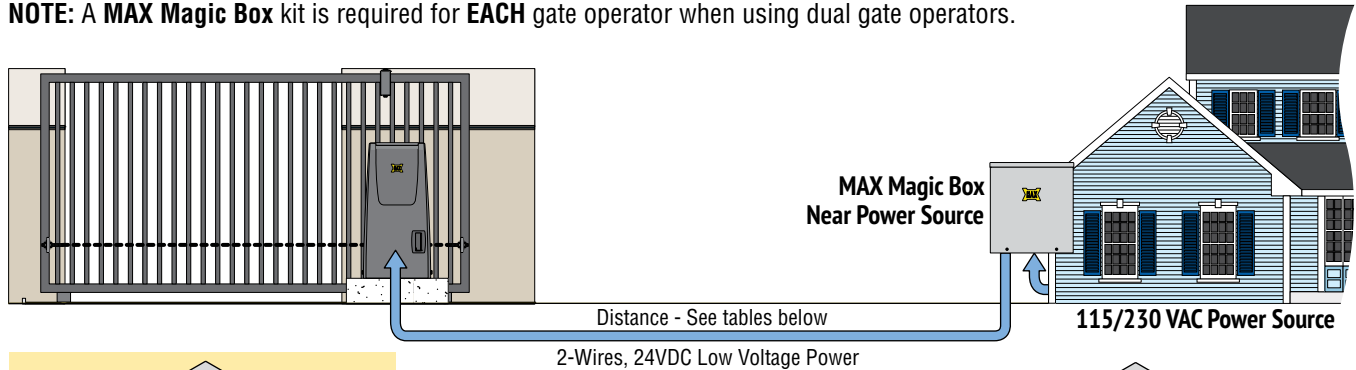

Level Gate		
Gate Weight	Max Wire Distance - Wire Gauge	
1600 lbs	300 ft - 10AWG	500 ft - 8AWG
Uphill Gate - 5° Max		
Gate Weight	Max Wire Distance - Wire Gauge	
1000 lbs MAX	300 ft - 8AWG	

### At MAX Magic Box

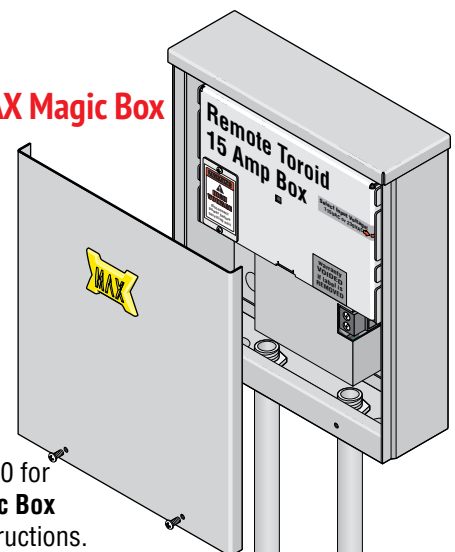

See page 20 for **MAX Magic Box** wiring instructions.

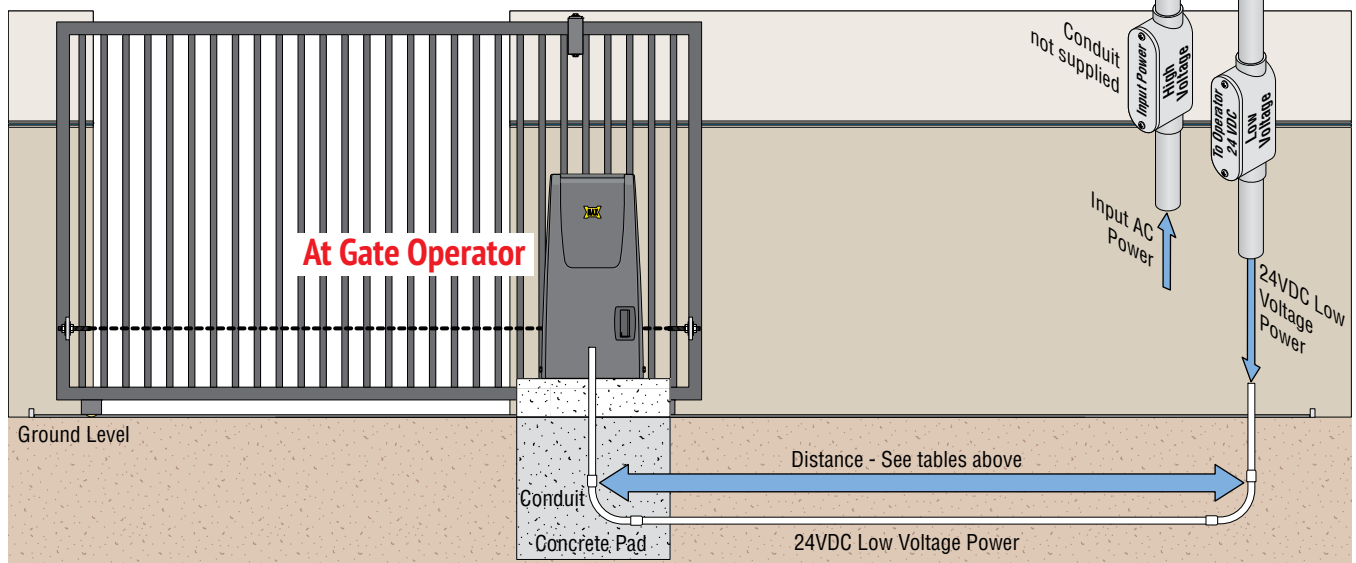

# INSTALLATION

## SOLAR - OPTIONAL

Refer to Solar application guide.

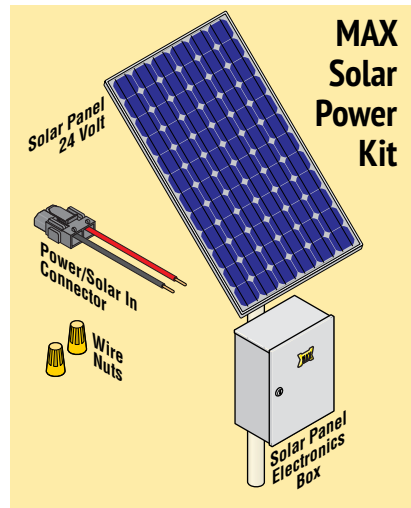

**MAX Solar Power Kit:** MUST be used when using solar power, sold separately.

**Solar Panel:** must be mounted facing south. It must get full sunlight throughout the day, **NO** shadow obstructions.

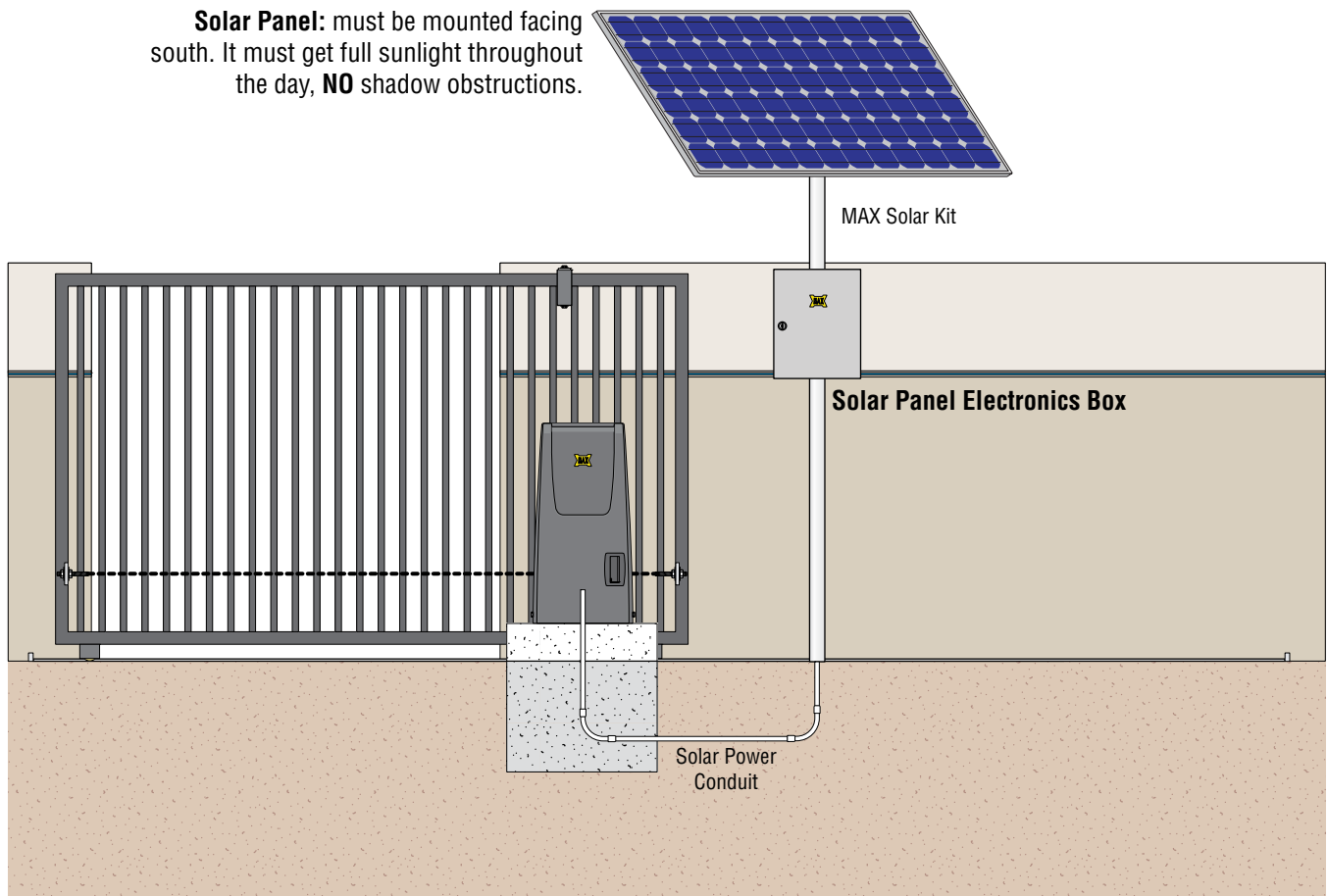

# INSTALLATION

## INSTALL WARNING SIGNS

A minimum of two (2) WARNING SIGNS shall be installed, one on each side of the gate where easily visible.

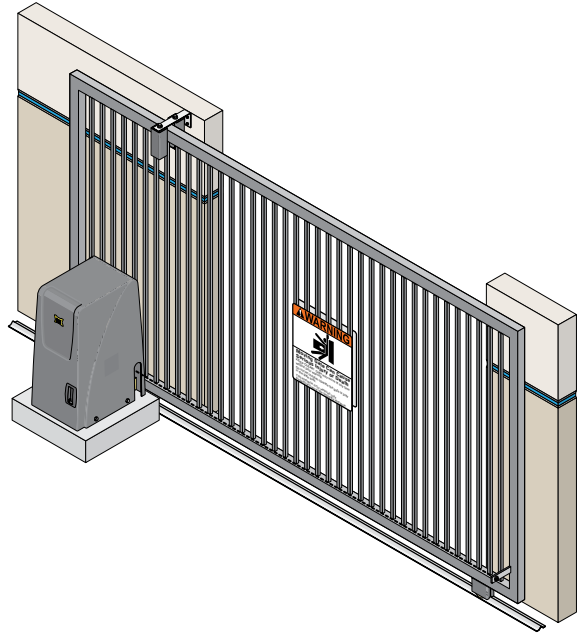

# INSTALLATION

## PHOTOCELL SAFETY AND ENTRAPMENT PROTECTION

Install photocells to help protect against secondary entrapment and safety protection during the cycling of the gate.  
See pages 18 and 25 for wiring instructions.

### UL 325 B1 (Secondary Entrapment Protection)

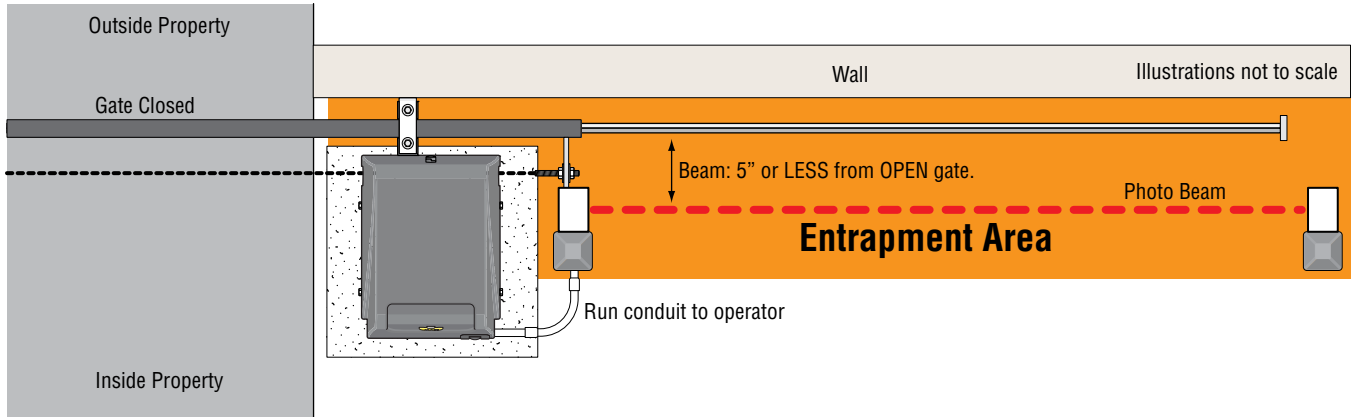

### Photocell Beam Height

Install photocells on either side of gate, as close as practical to the gate but no further away than 5".

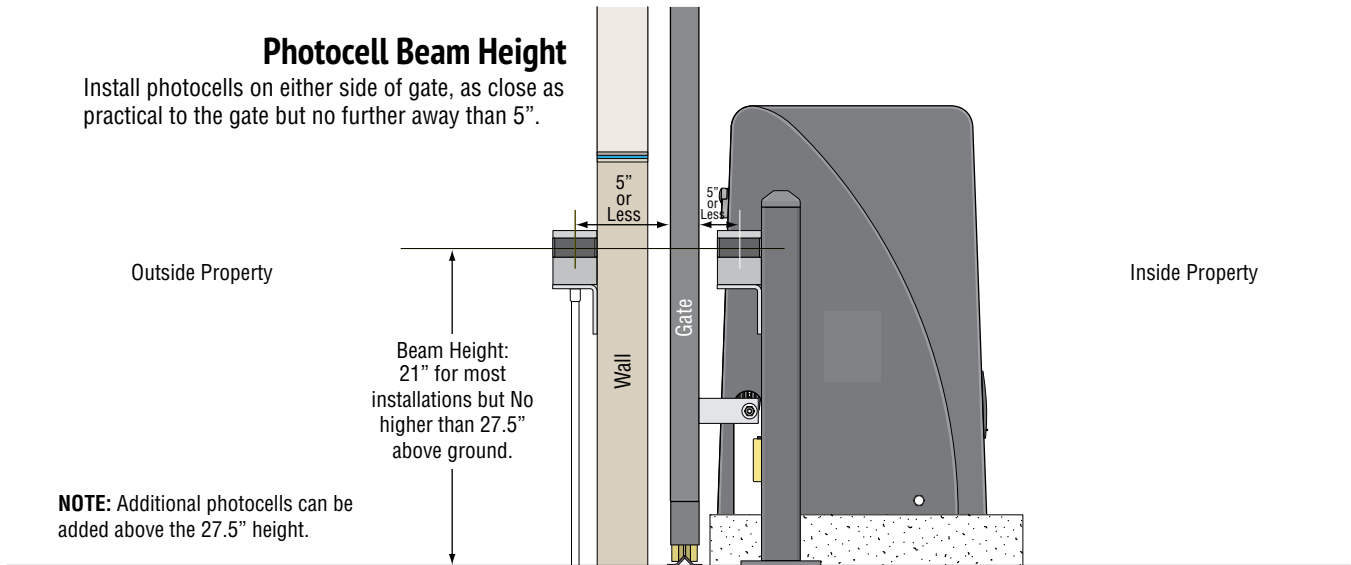

### CLOSING Cycle Safety Protection

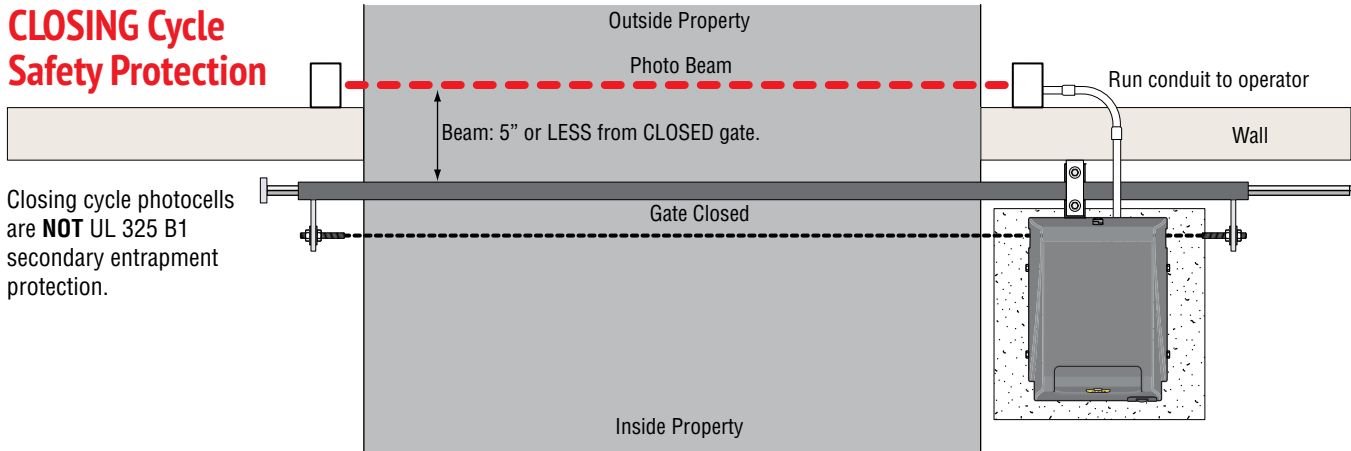

Closing cycle photocells are **NOT** UL 325 B1 secondary entrapment protection.



# INSTALLATION

## **SENSING EDGE SAFETY AND ENTRAPMENT PROTECTION**

Install sensing edges to help protect against certain UL gate classifications secondary entrapment protection (see table on page 3) and safety protection during the cycling of the gate.

Run sensing edge wires to operator. See pages 18 and 25 for wiring information.

### **UL 325 B2 (Certain UL Gate Classifications Secondary Entrapment Protection)**

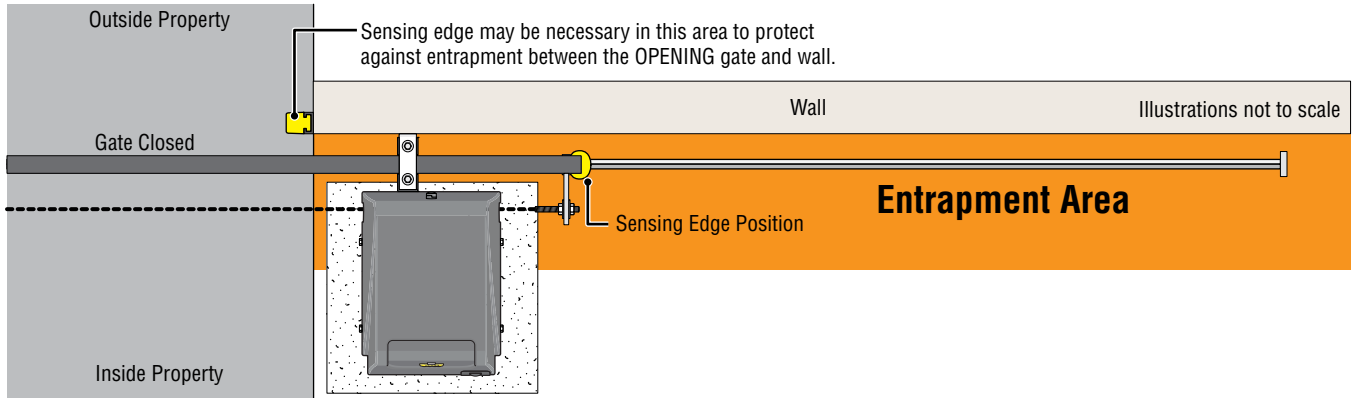

### **Sensing Edges**

Install on both ends of the gate and the opening next to gate for added safety protection against entrapment or gate hitting a vehicle.

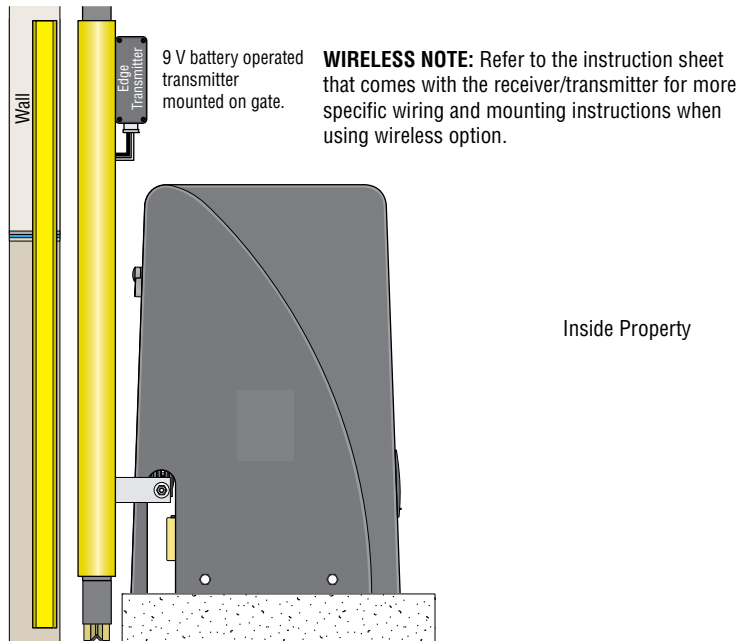

**NOTE:** Additional sensing edges can be added where needed.

### **CLOSING Cycle Safety Protection**

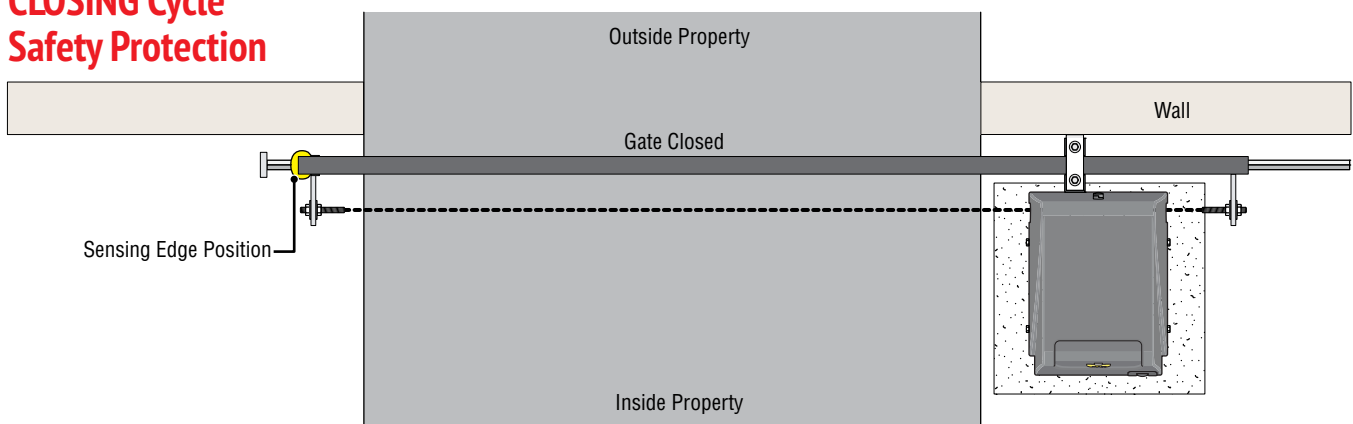

# INSTALLATION

## IN-GROUND LOOPS

Install in-ground loops to help protect vehicles from a moving gate. See pages 25 & 29 for wiring instructions.

Refer to loop manufacturer's instructions to determine specific loop dimensions.

**It is recommended that a licenced installer perform this work.**

Illustration not to scale

### Side View of Saw Cut

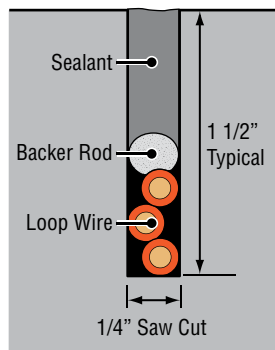

Pavement

### Safety Loops

Are placed on each side of the gate to prevent the gate from closing on a vehicle in its path. They will stop or reverse the cycling of the gate while a vehicle is in or near the gate's pathway.

### Exit Loop

Automatically opens the gate for exiting vehicles without having to use a radio transmitter (remote control). The exit loop can be placed a minimum of 4 feet away from the safety loop or far enough away from the gate so it has opened by the time the vehicle approaches it.

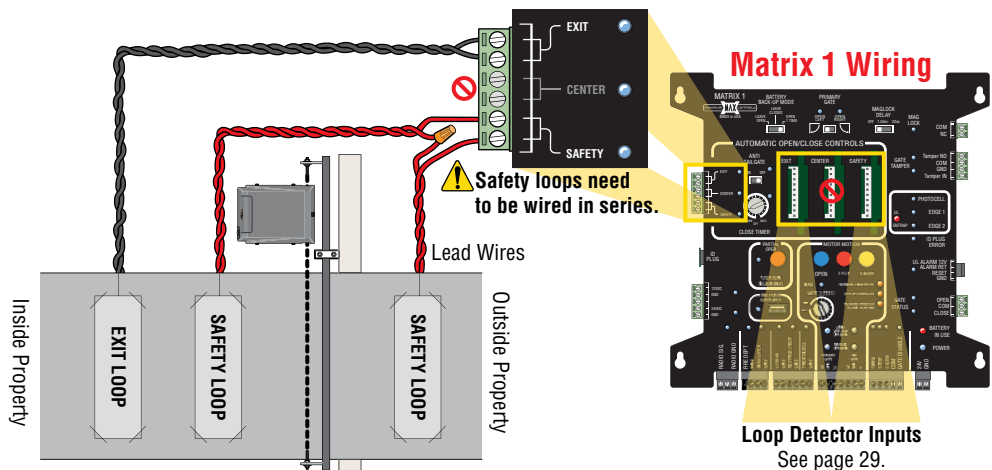
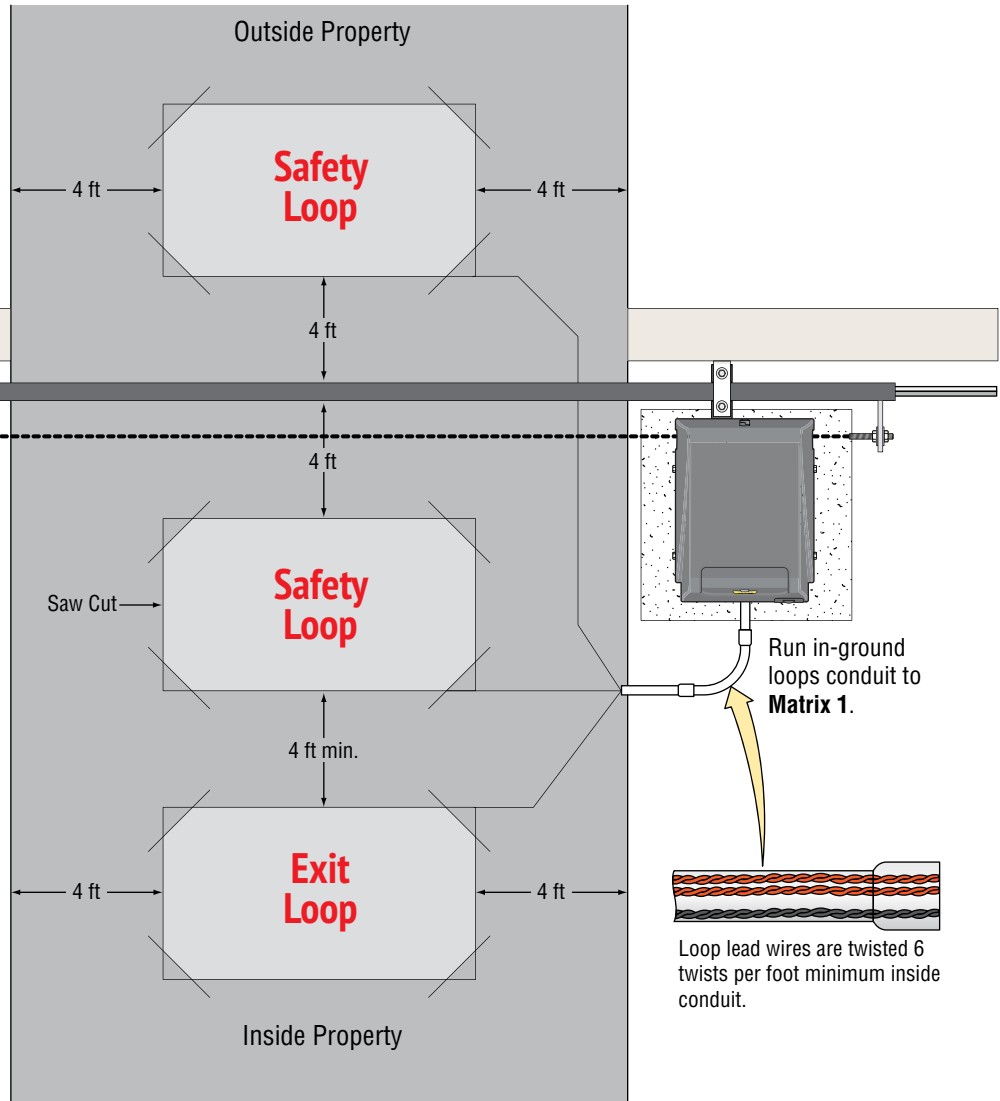

# WIRING OPERATOR

Check with local building department prior to installing any permanent wiring on this gate operator. Make sure all wiring complies with local code requirements.

## GATE OPERATOR SYSTEM OVERVIEW

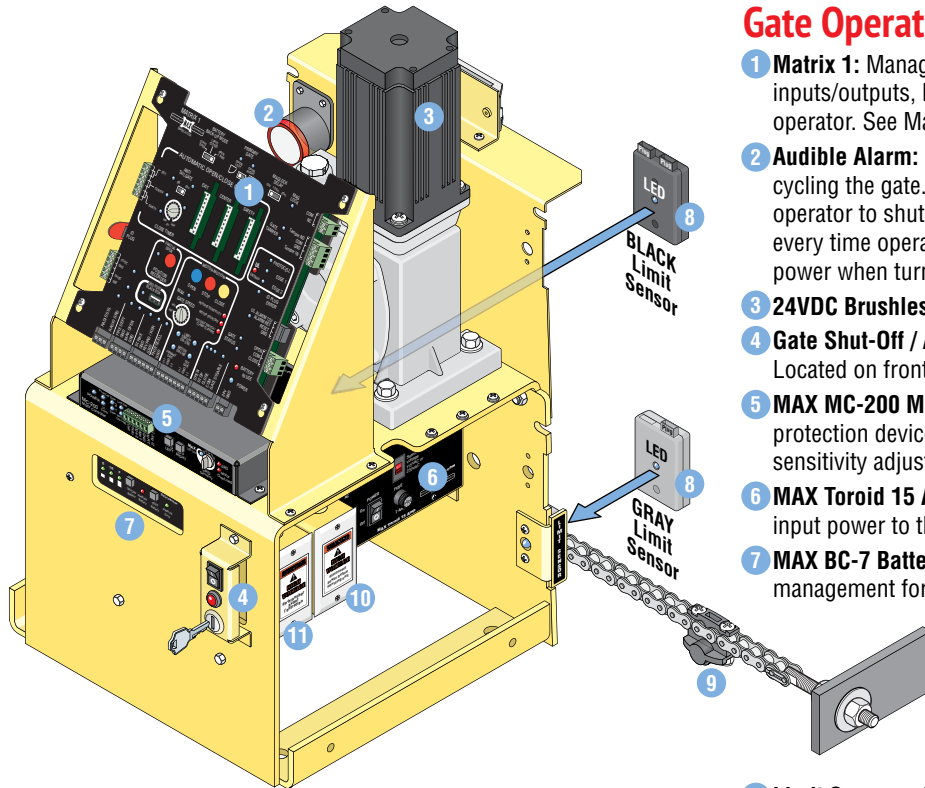

### Gate Operator

- 1 Matrix 1:** Manages control panel operations. Manages inputs/outputs, loops and reports problems with gate operator. See Matrix 1 Section starting on page 24.
- 2 Audible Alarm:** Sounds when there is a problem with cycling the gate. Push the alarm reset button on the operator to shut off alarm (see below). Alarm can sound every time operator is cycled using ONLY battery back-up power when turned ON, See page 42.
- 3 24VDC Brushless Motor (6 million cycles)**
- 4 Gate Shut-Off / Alarm Reset / Electronic Gate Open/Close:** Located on front of operator cover. See A, B, C below.
- 5 MAX MC-200 Motor Controller:** Manages UL entrapment protection devices and operator motor reversing ERD sensitivity adjustment. See pages 18, 23, 25 & 35.
- 6 MAX Toroid 15 Amp Box:** AC power management for the AC input power to the gate operator. See pages 19, 20 & 23.
- 7 MAX BC-7 Battery Module:** Battery Back-Up and DC power management for the gate operator. See page 26.

- 8 Limit Sensors:** Communicates gate cycling positions with Matrix 1. See pages 30, 36 & 41.
- 9 Limit Sensor Activators (Magnets):** **MUST be** mounted on chain in the desired OPEN and CLOSE gate positions to activate the limit sensors. LED will light when activated. See page 36.
- 10 AC Power Gang Box:** Input AC power wire connection. See page 19.
- 11 Additional Gang Box:** Single gang box to wire a GFCI outlet for additional power outlets if desired. See page 19.

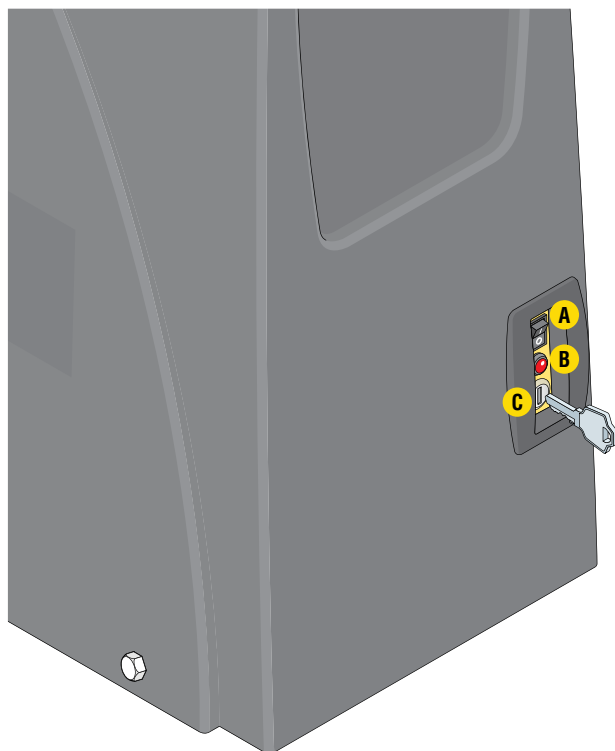

### Gate Shut-Off / Alarm Reset / Electronic Gate Open/Close

- A Gate Shut-Off Switch:** If turned **ON**, prevents any control devices from operating gate when servicing operator. Only the Jog left, right buttons on MC-200 motor controller will operate gate. See pages 34 and 41 for complete information about Gate Shut-Off Switch functions.
- B Alarm Reset Button:** Push to shut off alarm and/or reset Matrix 1. See pages 31, 37 & 42.
- C Electronic Gate Open/Close:** Electronically move the gate open or closed by turning removable key. See page 41.

# WIRING OPERATOR

## GATE OPERATOR SYSTEM OVERVIEW CONTINUED

### MAX BC-7 Battery Module

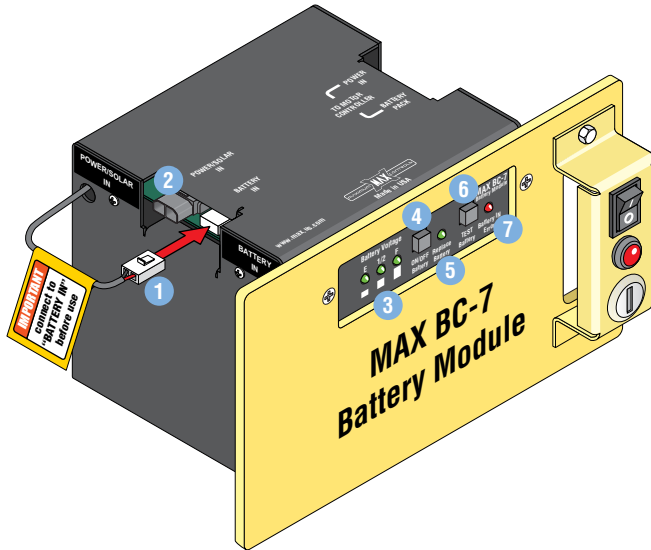

- 1 **BATTERY Plug:** MUST be plugged into **BATTERY IN** port **Before** use.
- 2 **POWER/SOLAR IN Port:** MAX Toroid 15 Amp Box connection.
- 3 **Battery Voltage LEDs:** Show amount of battery power available. LEDs are always ON when using AC power. Test battery button must be pressed to show battery power when using battery power ONLY.
- 4 **ON/OFF Battery Button:**  
**IMPORTANT:** Battery power **automatically** turns **ON** when MAX Toroid 15 Amp Box **AC POWER Switch** is turned **ON**.  
**To turn OFF ALL POWER to operator:**
  1. Turn OFF **AC POWER Switch** on MAX Toroid 15 Amp Box. Battery power **remains ON**.
  2. **WAIT** for 15 seconds.
  3. **Press and HOLD** (approx. 5 seconds) the **YELLOW ON/OFF BATTERY** button until MAX BC-7 LEDs turn **ON**, then release button. LEDs will turn **OFF**.
- 5 **Replace Battery LED:** Replace battery when lit.
- 6 **TEST Battery Button:** Press to show amount of battery power available when using battery power ONLY (Battery voltage LEDs will light respectively).
- 7 **Battery IN Error LED:** Lights when there is a battery connection problem. Make sure battery plug #1 is plugged into BATTERY IN port or there are no damaged or loose wires.

### MAX MC-200 Motor Controller

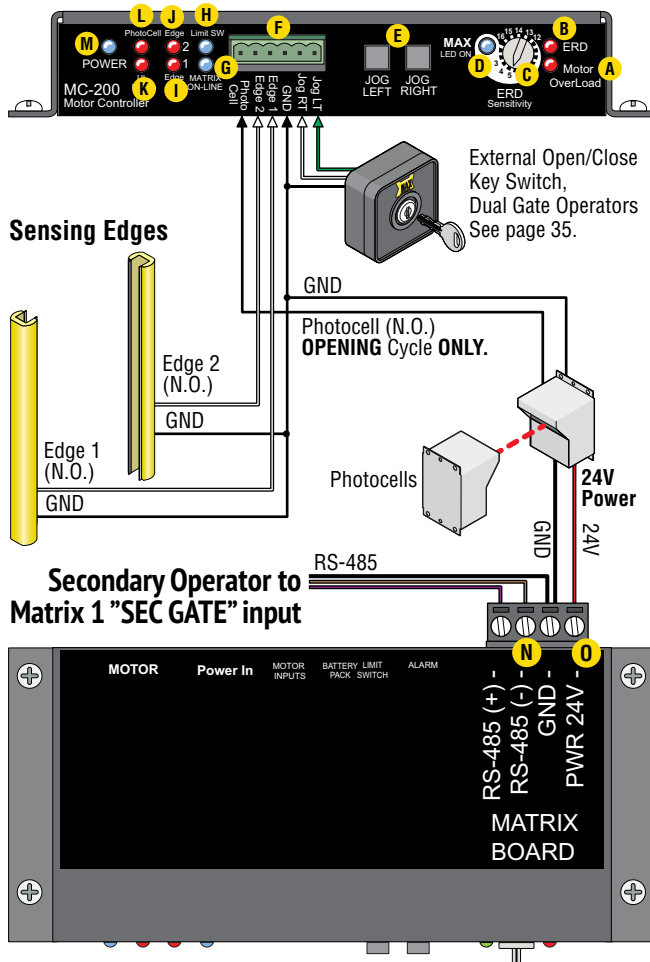

- A MOTOR OVERLOAD LED:** Excessive current being drawn by motor when lit.
  - B ERD LED:** ERD sensor has been activated when lit.
  - C ERD Sensitivity Knob:** 16 selectable sensitivity settings of ERD sensor.
  - D ERD Sensitivity LED:** MAX sensitivity reached when lit.
  - E Jog LEFT/RIGHT Buttons:**  
Push and **HOLD** buttons accordingly to move the gate (release the button to stop gate). **WARNING:** Avoid moving gate while using Jog buttons.
  - F INPUTS:**
    - Jog LT/RT:** Can connect to an External Open/Close Key switch. Connect a single key switch to control dual gate operators, See page 35.
    - GND:** Low Voltage Common connection.
    - Edge 1:** Connects to a Sensing Edge. Multiple sensing edges can be connected.
    - Edge 2:** Connects to a second Sensing Edge. Multiple sensing edges can be connected.
    - PHOTOCELL:** Connects to a UL 325 Standard **Entrapment** photocell **ONLY**. Multiple **Entrapment** photocells can be connected.
  - G Matrix On Line LED:** Gate operator is successfully communicating with Matrix 1 when lit.
  - H Limit SW On Line LED:** Limit Switch Sensors are successfully communicating with MC-200 Motor Controller when lit.
  - I Edge 1 LED:** Reversing Edge 1 input has been activated when lit.
  - J Edge 2 LED:** Reversing Edge 2 input has been activated when lit.
  - K UL Entrap LED:** Edge1/Edge2/Photocell input has been activated when lit.
  - L Photocell LED:** Photocell input has been activated when lit.
  - M Power LED:** Low voltage power is connected when lit.
  - N RS-485 Input:** Factory wired for **Primary** operator.  
Wire to Matrix 1 "SEC GATE" for **Secondary** operator **ONLY**.
  - O 24V Power Input:** Power 24V photocells if desired.
- DUAL GATE OPERATORS NOTE:** Connect **EACH** photocell/sensing edge to the **corresponding** gate operator. See page 10.

# WIRING OPERATOR

## HIGH VOLTAGE INPUT AC POWER

**DO NOT TURN OPERATOR POWER ON AT THIS TIME.**

Choose either **115V** or **230V** setting on input **AC power selector switch**.

Wire desired input AC power wire to power terminal. A additional single gang box is provided to install power outlets if desired. GFCI outlet type is recommended.

**NOTE:** AC power wire is required for **EACH** gate operator when using dual gate operators.

**CAUTION:** MAKE SURE CIRCUIT BREAKER IS OFF AT AC POWER SOURCE BEFORE WIRING

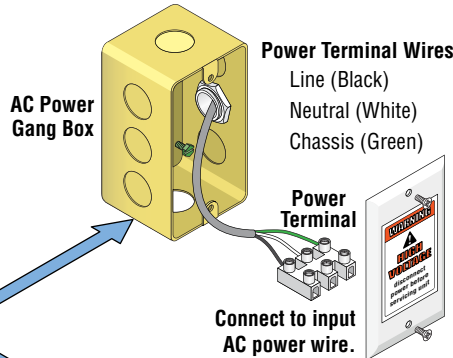
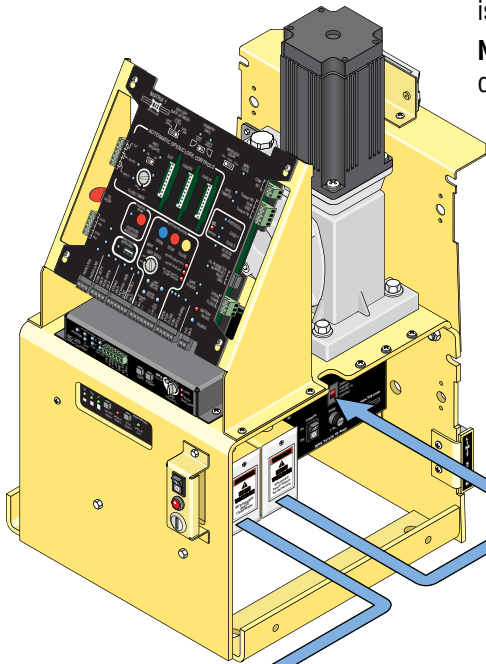

**IMPORTANT NOTE:** Make sure there are **NO** exposed bare wires at the power terminal connection.

## Input AC Power Options

Single Phase 115VAC Only

**115VAC**



Single Phase 230VAC Only

**230VAC**



**CAUTION:** If power selector switch is set for **115V** but input power is actually **230V**, 7 Amp Fuse will blow.

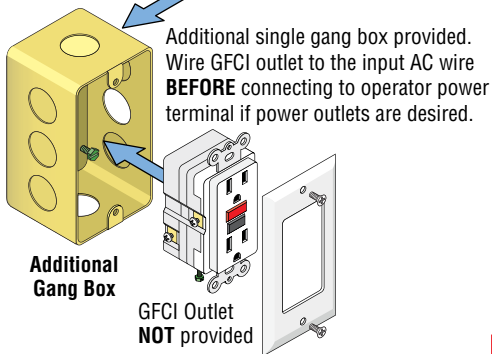

## Operator MUST be Properly GROUND

Any of the **THREE** Chassis Grounds can be used. They are located next to the gear reducer. **DO NOT** remove any existing green ground wires.

**WARNING**  
connect chassis to ground rod for lightning protection

Proper grounding of this gate operator is a requirement for **LIGHTNING PROTECTION** in lightning prone areas. To be effective, ground connections should be made with a **minimum 12 AWG, 600 volt insulated wire**

to a ground point within **10 feet** of the gate operator. The ground point must be at an **electrical panel**, a **metallic cold water pipe** that runs in the earth, or a **grounding rod**.

**NOTE:** Consult city codes for AC line wiring. Beware of existing underground services.

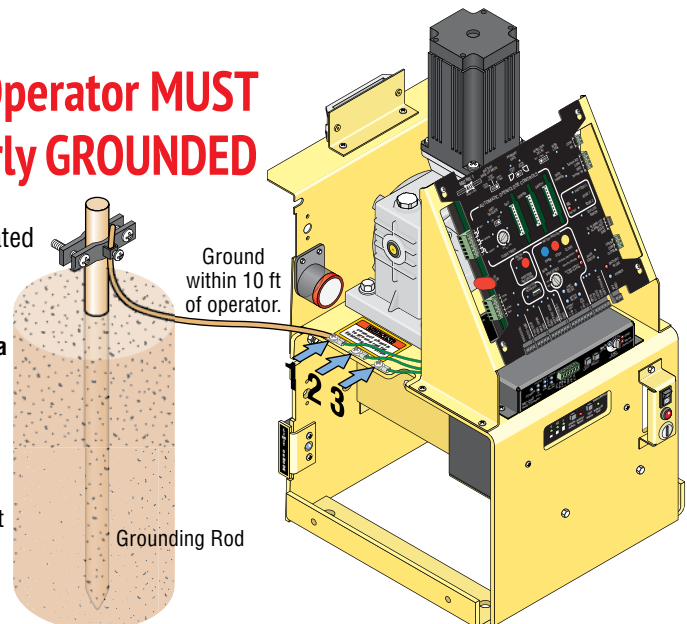



# WIRING OPERATOR

## LOW VOLTAGE REMOTE POWER SUPPLY KIT - OPTIONAL

A **MAX Magic Box Kit** (sold separately) is required to remotely install a **MAX Toroid 15 Amp box** at the AC power source. Plug in Remote Toroid 15 Amp connector to **Power In** at MAX Magic Box. Wire input AC power to the Toroid 15 Amp box. Choose either **115V** or **230V** setting on input AC power selector switch. Run 24V low voltage wires (not included) from the **MAX Magic Box** connection to the gate operator and wire to **POWER/SOLAR IN** connector (Polarity Matters!). Remove the MAX Toroid 15 Amp connector from the BC-7 battery module **POWER/SOLAR IN** port. Plug the Magic Box **POWER/SOLAR IN** connector into the **POWER/SOLAR IN** port.

### At MAX Magic Box

**NOTE:** A **MAX Magic Box kit** is required for **EACH** gate operator when using dual gate operators.

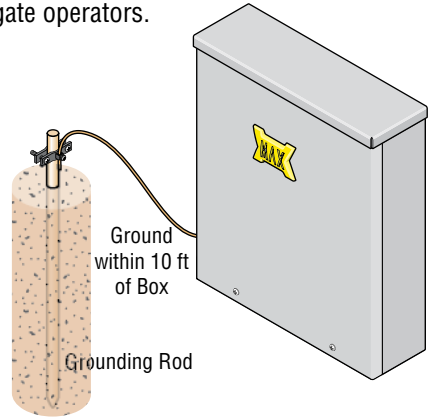
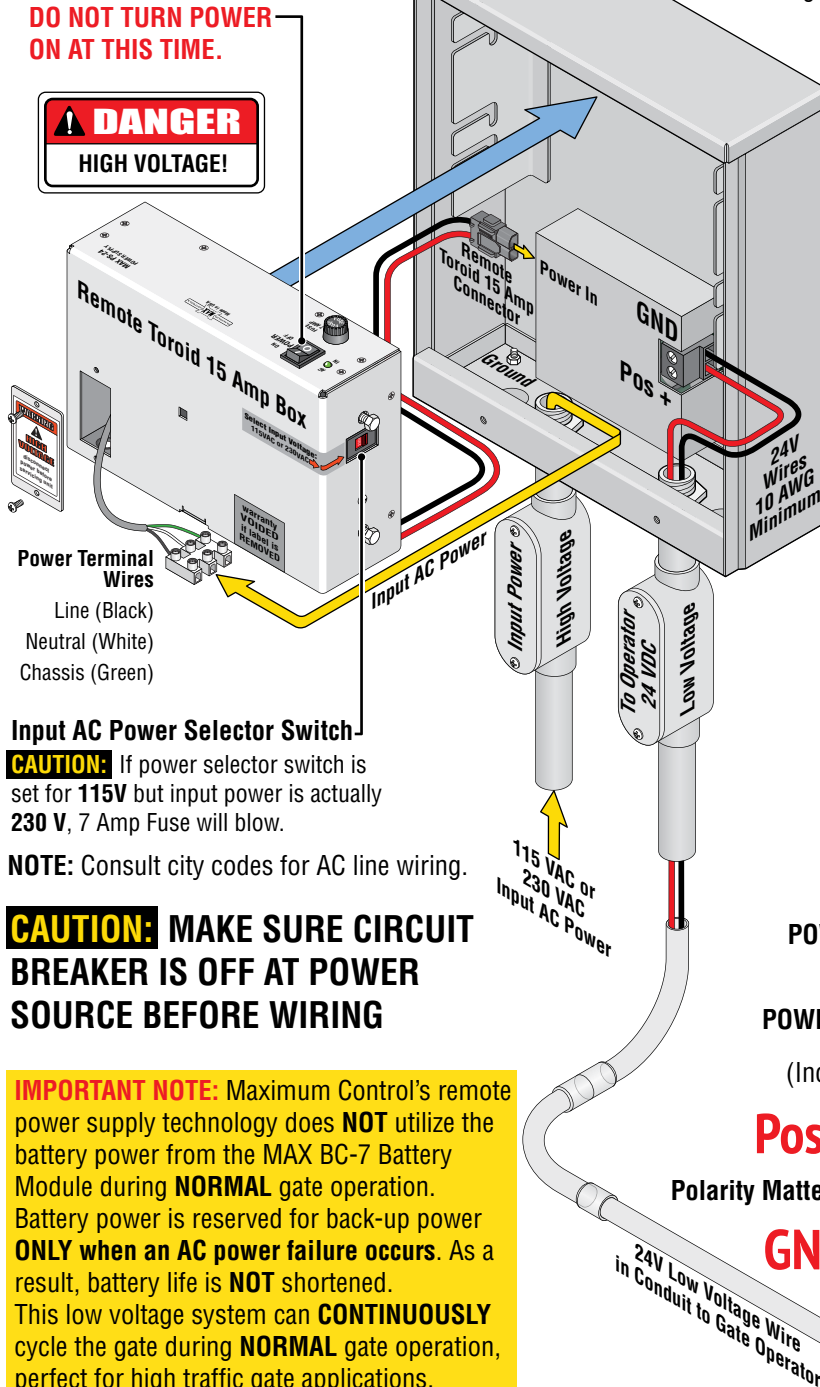

### MAX Magic Box MUST be Properly GROUND

**IMPORTANT:** MAX Magic Box and Gate Operator **MUST EACH** be Properly **GROUND**. Proper grounding is a requirement for **LIGHTNING PROTECTION** in lightning prone areas. To be effective, ground connections should be made with a **minimum 12 AWG, 600 volt insulated wire** to a ground point within **10 feet of the MAX Magic Box and gate operator**. The ground point must be at an **electrical panel, a metallic cold water pipe** that runs in the earth, or a **grounding rod**.

**NOTE:** Beware of existing underground services.

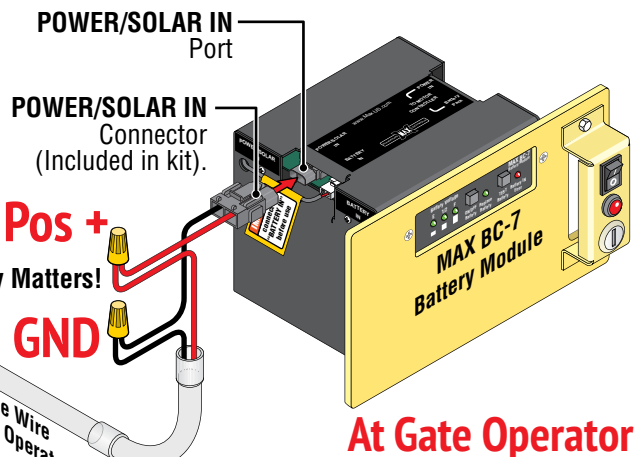

### At Gate Operator

# WIRING OPERATOR

## SOLAR POWER CONNECTION - OPTIONAL

Refer to Solar application guide.

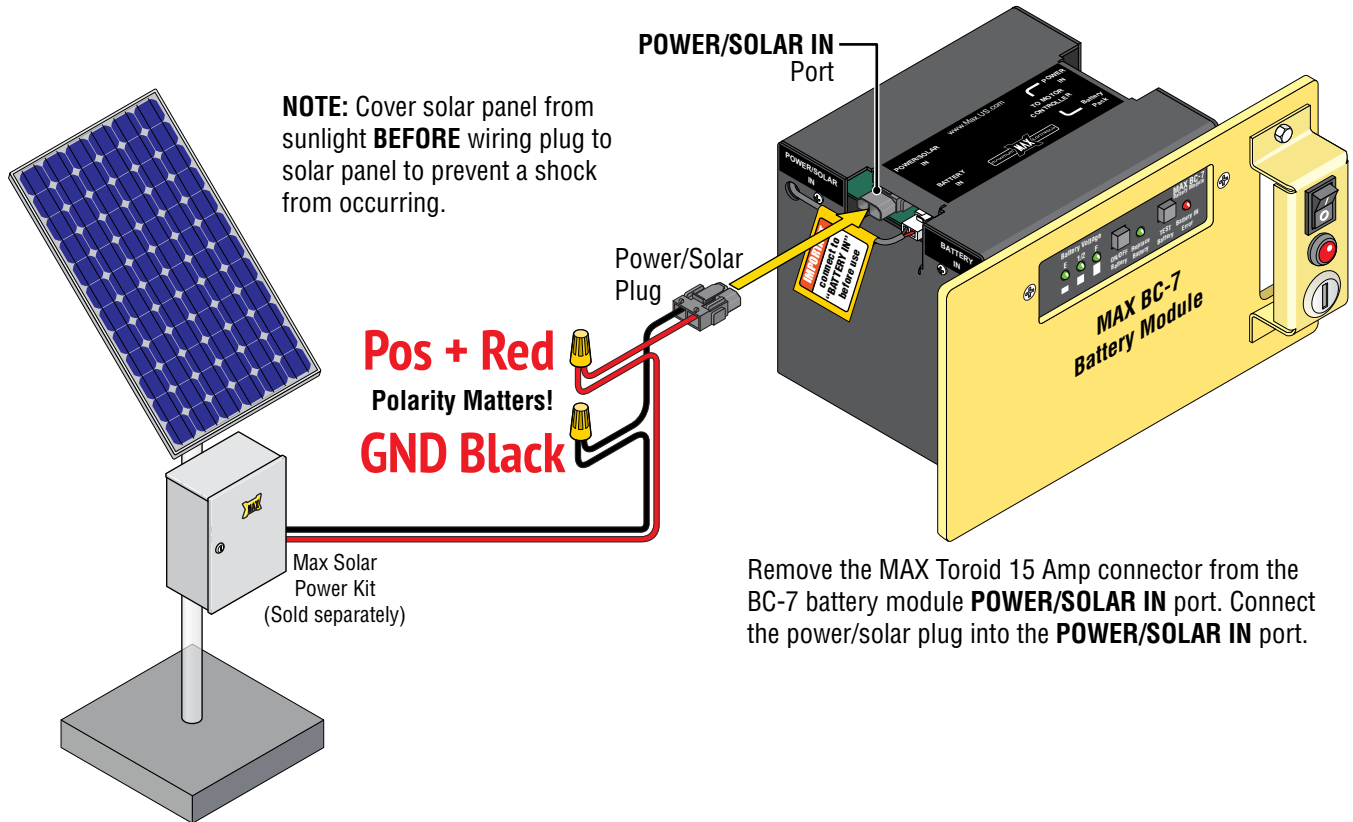

# WIRING OPERATOR

## SECONDARY OPERATOR TO MATRIX 1

Unplug 4-Pin plug from the back of the **MAX MC-200 motor controller** and connect RS-485 wires as shown below.

**Secondary Gate Operator**

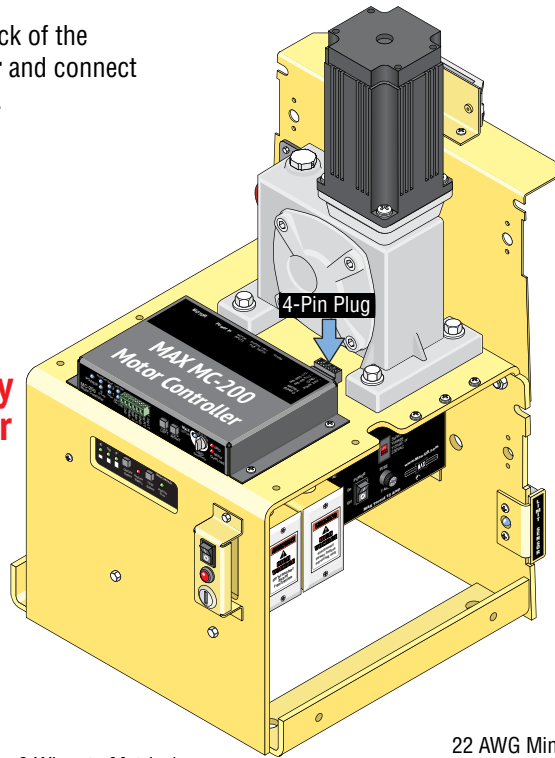

**Primary/Single Gate Operator Matrix 1**

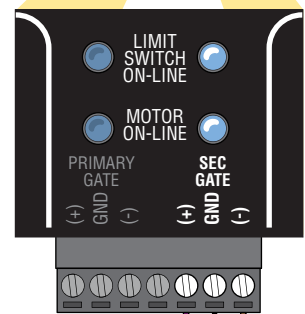
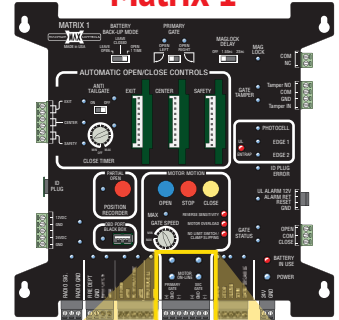

3 Wires to Matrix 1

22 AWG Min. 3-conductor twisted pair, shielded cable

**NO 24V to Matrix 1**

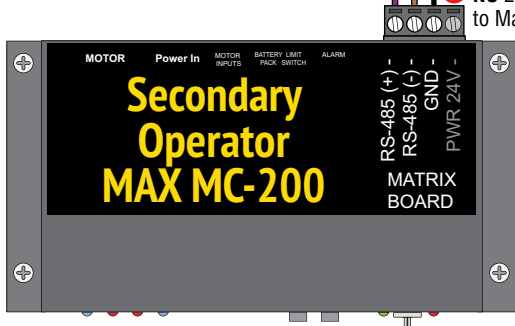

Connect (3) three RS-485 wires from the **SECONDARY** operator's **MAX MC-200** motor controller to the **Matrix 1 - SEC GATE**. **DO NOT** connect **PWR 24V**.





# WIRING OPERATOR

## TURN ON/OFF OPERATOR POWER

Operator should have **Input AC power wired** to MAX Toroid box, **24V & RS-485** wired between Matrix 1 and MC-200 and “Optional” **External Jog switch** wired to MC-200. **TURN POWER ON**. Certain LEDs should normally turn ON accordingly:

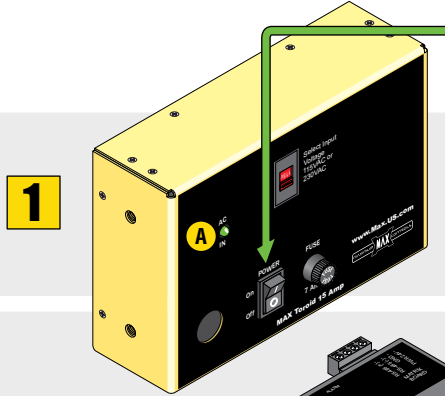

### Turn AC Power Switch ON

Battery power automatically turns ON.

### DO NOT CYCLE GATE OPERATOR AT THIS TIME

Open and Close Limit Sensor Activators **MUST** be installed on chain **BEFORE** cycling gate or **DAMAGE CAN OCCUR!**

1

#### MAX Toroid 15 Amp Box

##### A AC IN LED:

**Normal** - Turns ON.

**Error** - Not ON. Check AC power.

7 Amp Fuse blown. Replace fuse.

Input AC selector switch **MUST** be set to **CORRECT** input AC power.

2

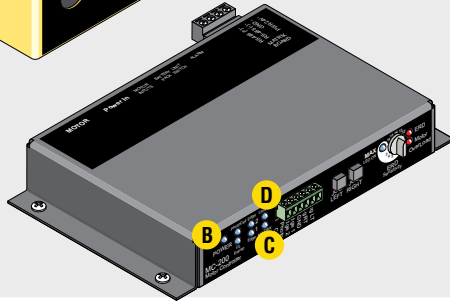

#### MAX MC-200 Motor Controller

##### B POWER LED:

**Normal** - Turns ON.

**Error** - Not ON. Check **POWER IN** plug on back of MC-200.

##### C Matrix On-Line LED:

**Normal** - Turns ON.

**Error** - Not ON. Check **RS-485** wiring to Matrix 1.

##### D Limit SW On-Line LED:

**Normal** - Turns ON.

**Error** - Not ON. Check **LIMIT SWITCH** plug.

3

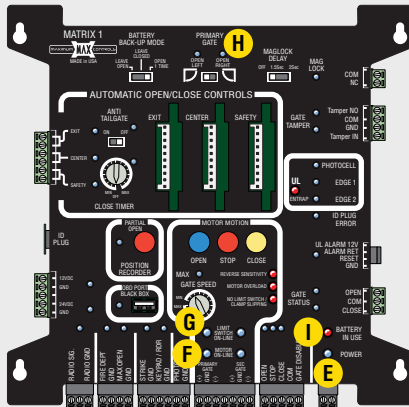

#### Matrix 1

##### E POWER LED:

**Normal** - Turns ON.

**Error** - Not ON. Check **24V** wiring from MC-200 **Primary/Single**.

##### F Motor On-Line PRIMARY LED (Secondary LED if installed):

**Normal** - Turns ON.

**Error** - Not ON. Check **RS-485** wiring to **Primary/Single** MC-200.

##### G Limit SW On-Line PRIMARY LED (Secondary LED if installed):

**Normal** - Turns ON.

##### H PRIMARY GATE OPEN RIGHT OPEN LEFT LED:

**Normal** - Turns ON either LED according to switch setting.

**Error** - Not ON. Check **LIMIT SWITCH** plug on back of MC-200.

##### I BATTERY IN USE LED:

**Normal** - Not ON.

**Error** - Flashes on and off. Battery not plugged in to **BATTERY IN** port on BC-7 Battery Module.

4

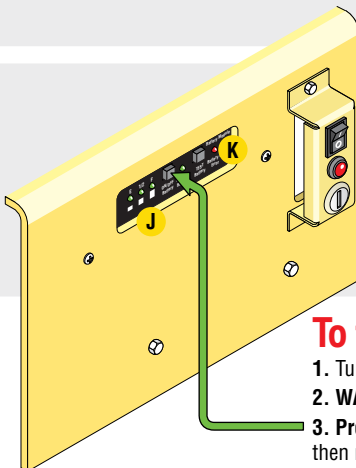

#### MAX BC-7 Battery Module

##### J BATTERY VOLTAGE LEDs:

**Normal** - 3 LEDs turn ON - Fully charged batteries.

**Batteries need charging** - LEDs will turn on in sequence until batteries are fully charged. Batteries are **NOT** necessary when AC power is available.

##### K BATTERY IN ERROR LED:

**Normal** - Not ON.

**Error** - Turns ON. Battery not plugged in to **BATTERY IN** port.

### To turn OFF ALL POWER:

1. Turn OFF **AC POWER** Switch on MAX Toroid 15 Amp. Battery power **remains ON**.

2. **WAIT** for 15 seconds.

3. **Press and HOLD** (approx. 5 seconds) the **ON/OFF BATTERY** button until MAX BC-7 LEDs turn **ON**, then release button. LEDs will turn **OFF**.

# MATRIX 1

## MATRIX 1 OVERVIEW

- 1 Battery Back-Up Mode - Page 26
- 2 Primary Gate - Page 26
- 3 Maglock - Page 29
- 4 Gate Tamper - Page 30
- 5 In-Ground Loop Connection - Page 29
- 6 Anti Tailgate - Page 27
- 7 Loop Detectors - Page 29
- 8 UL Entrapment LEDs - Page 30
- 9 Close Timer - Page 26
- 10 ID Plug & ID Plug Error LED - Page 30
- 11 UL Alarm Strobe Light Input - Page 31
- 12 Gate Shut-Off Switch (Factory Installed) - Page 34
- 13 Radio Power - Page 28
- 14 Partial Open - Page 31
- 15 OBD Port Black Box - Page 28
- 16 Selectable Gate Speed Control - Page 26
- 17 Motor Motion LEDs - Page 32
- 18 Gate Status - Page 32
- 19 Radio Relay - Page 28
- 20 Emergency Vehicle/Max Open Inputs - Page 30
- 21 Normal Opening Devices - Page 25
- 22 Close Photocell - Page 32
- 23 Operators Communication LEDs - Page 22 & 33
- 24 OPEN/STOP/CLOSE Connection - Page 32
- 25 Gate Disable - Page 31
- 26 Matrix 1 Power - Page 33

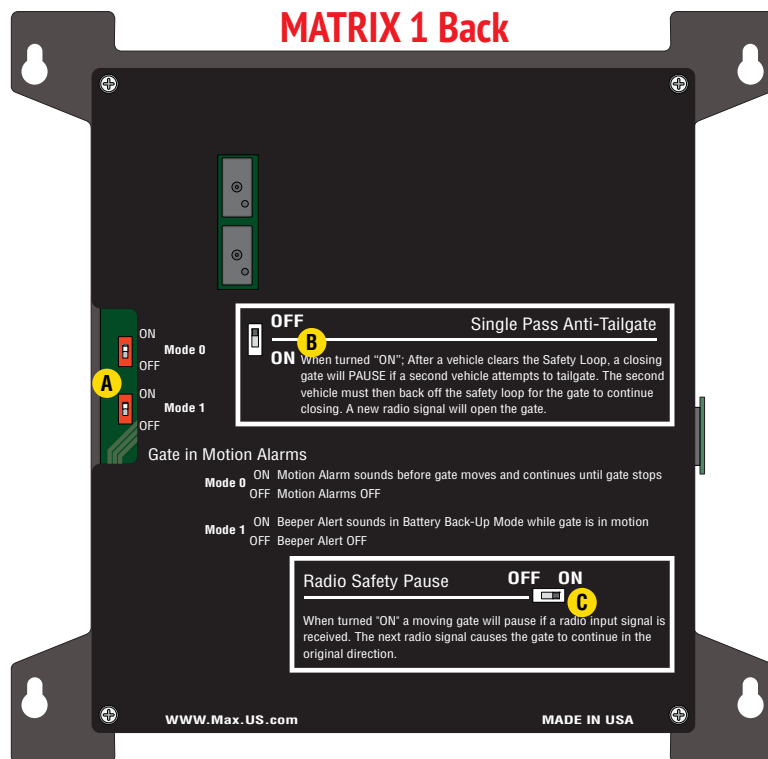
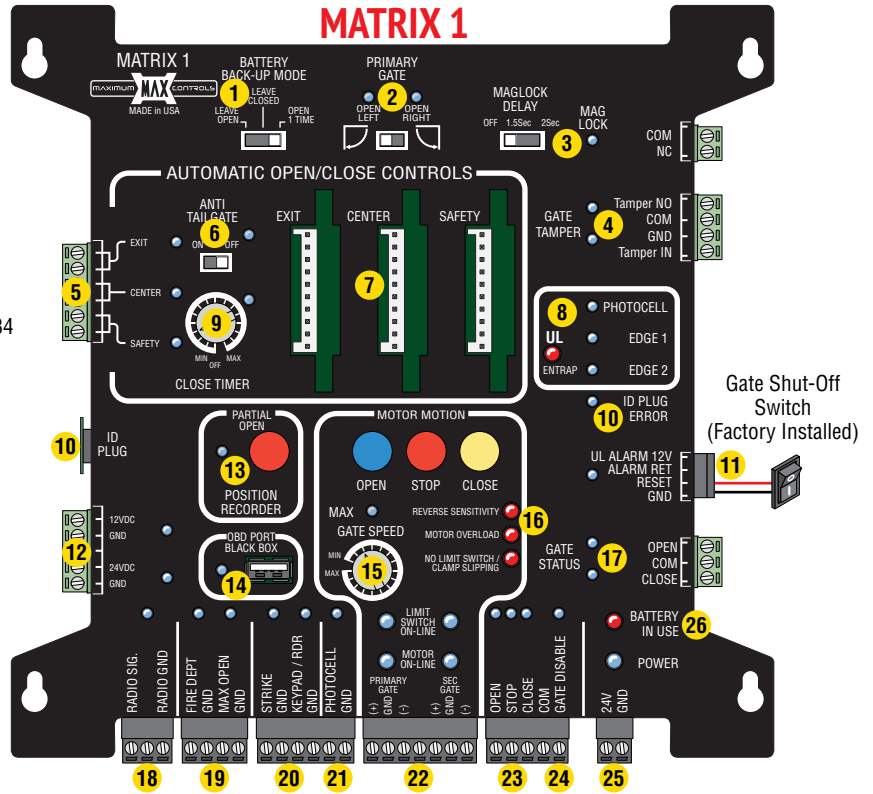

- A** Gate in Motion Alarms - Page 28
- B** Single Pass Anti-Tailgate - Page 27
- C** Radio Safety Pause - Page 28

# MATRIX 1

## WIRING OVERVIEW

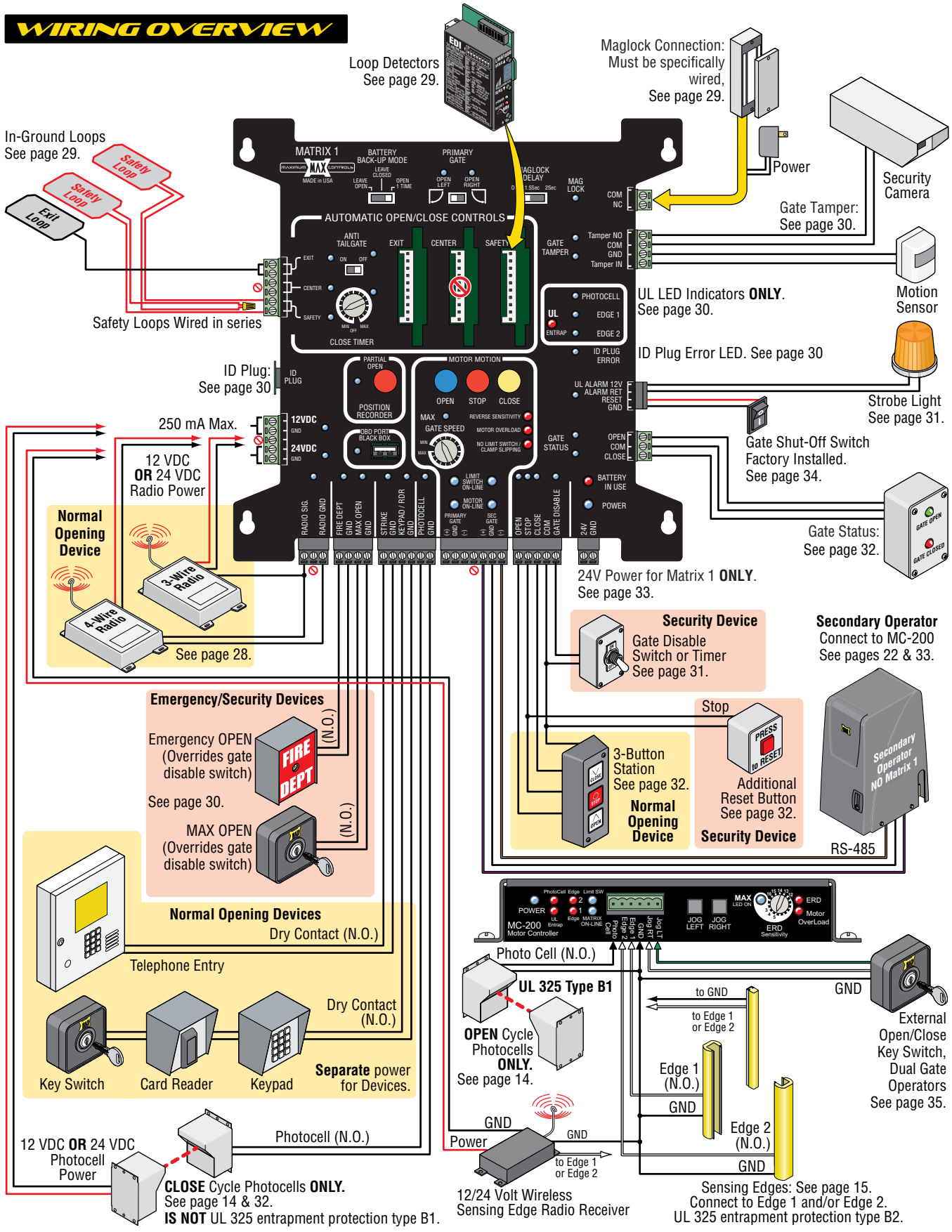

In-Ground Loops  
See page 29.

Loop Detectors  
See page 29.

Maglock Connection:  
Must be specifically  
wired,  
See page 29.

Safety Loops Wired in series

ID Plug:  
See page 30

250 mA Max.

12 VDC  
OR 24 VDC  
Radio Power

Normal  
Opening  
Device

### Emergency/Security Devices

Emergency OPEN  
(Overrides gate  
disable switch)  
See page 30.

MAX OPEN  
(Overrides gate  
disable switch)

### Normal Opening Devices

Telephone Entry

12 VDC OR 24 VDC  
Photocell  
Power

**CLOSE** Cycle Photocells **ONLY**.  
See page 14 & 32.  
**IS NOT** UL 325 entrapment protection type B1.

UL LED Indicators **ONLY**.  
See page 30.

ID Plug Error LED. See page 30

24V Power for Matrix 1 **ONLY**.  
See page 33.

### Security Device

Gate Disable  
Switch or Timer  
See page 31.

Secondary Operator  
Connect to MC-200  
See pages 22 & 33.

Stop

3-Button  
Station  
See page 32.

Normal  
Opening  
Device

Additional  
Reset Button  
See page 32.

Security Device

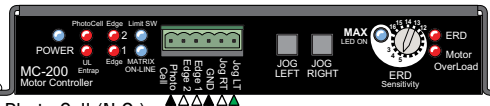
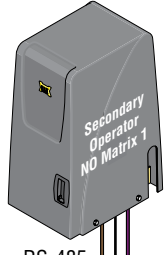

Photo Cell (N.O.)  
UL 325 Type B1  
OPEN Cycle  
Photocells  
**ONLY**.  
See page 14.

12/24 Volt Wireless  
Sensing Edge Radio Receiver

External  
Open/Close  
Key Switch,  
Dual Gate  
Operators  
See page 35.

Sensing Edges: See page 15.  
Connect to Edge 1 and/or Edge 2.  
UL 325 entrapment protection type B2.

MATRIX 1

# MATRIX 1

## PRIMARY GATE - OPEN LEFT / OPEN RIGHT

Set the **Primary**/single gate operator with **Primary Gate** setting. Secondary operator will automatically be set to the opposite opening direction as the primary gate operator when using dual gates.

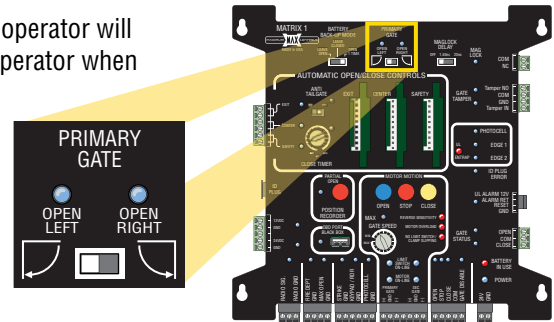
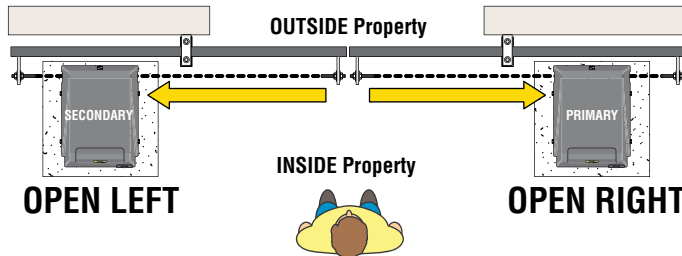

## GATE CLOSE TIMER

The **Close Timer** has 16 selectable settings for **automatic gate close time**.

**Knob at OFF position:** close timer OFF.

**1st click clockwise - Knob at MIN position:** 1/2 sec...

2nd click clockwise: 1 sec...

3rd click: 4 sec...

4th click: 8 sec...

5th click: 12 sec (4 sec increments for each successive click up to 60 sec **MAX**)

**NOTE:** 1/2 sec **MIN** position is recommended for **High Traffic areas**.

LED turns ON for  
**MAX** setting ONLY

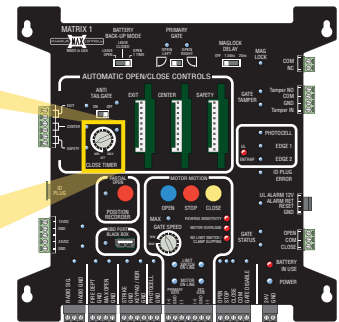
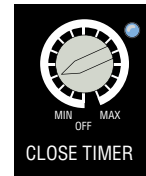

## SELECTABLE GATE SPEED CONTROL

The **Gate Speed** knob has 16 selectable settings to choose from, with maximum speed of 18 in/sec and minimum speed of 8 in/sec. Make sure gate speed is appropriate for the weight and length of the gate.

Limit sensor activators **MUST** be installed and gate positions learned **BEFORE** gate speed can be selected, see page 36.

**NOTE:** The **Auto Gate Sync** feature provides synchronous opening and closing between bi-parting gates (dual gate operators).

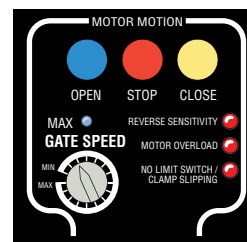

LED turns ON for  
**MAX** setting ONLY

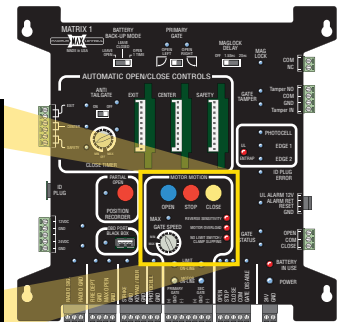

## BATTERY BACK-UP MODE

The **Battery Back-Up Mode** setting will determine how the gate operator will function during an AC power failure. The number of gate cycles on a fully charged battery, using only battery power depends on the weight and length of the gate.

**LEAVE OPEN** - The gate operator will continue to cycle the gate normally until the battery power can no longer cycle the gate. When this happens, the gate operator will open the gate and leave it in the **FULL OPEN position** until power is restored.

**LEAVE CLOSED** - The gate operator will continue to cycle the gate normally until the battery power can no longer cycle the gate. When this happens, the gate will close if not already in the **CLOSE position**, where it will remain until power is restored. Enough battery power is retained for a **LIMITED time** to operate emergency vehicle entry (Using opening devices connected to **FIRE DEPT** and/or **MAX OPEN** inputs to **FULLY** open gate).

**OPEN 1 TIME** - The gate operator will **automatically FULLY OPEN** gate once and leave it in the **OPEN position** until power is restored.

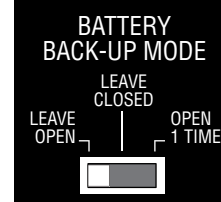

**FIRE DEPT/MAX OPEN Inputs**

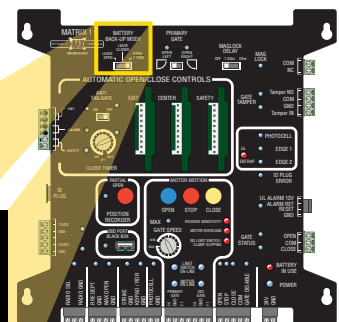

# MATRIX 1

## ANTI TAILGATE

**Turned OFF** - Close timer will close the gate. If an in-ground **safety** or **exit** loop gets activated during the close cycle, gate will **REVERSE** to the open position.

**Turned ON** - (In-ground loops required) Gate will close after **all the in-ground loops have been cleared** no matter how long the close timer is set for. If an in-ground safety loop gets activated during the close cycle, gate will **REVERSE** to the open position.

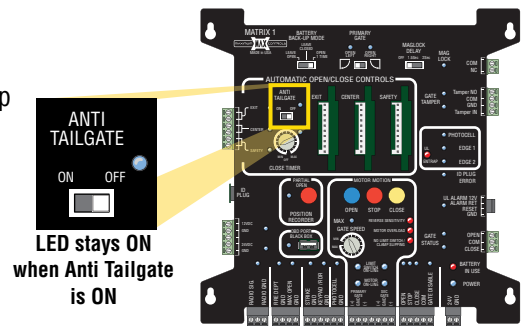

## SINGLE PASS ANTI-TAILGATE

**Turned ON** - (In-ground loops required) Gate will close after all the in-ground loops have been cleared no matter how long the close timer is set for. When an in-ground safety loop gets activated during the close cycle, gate will **PAUSE** and **NOT** reopen. When loop is cleared, gate will continue to close **preventing UNAUTHORIZED** entry.

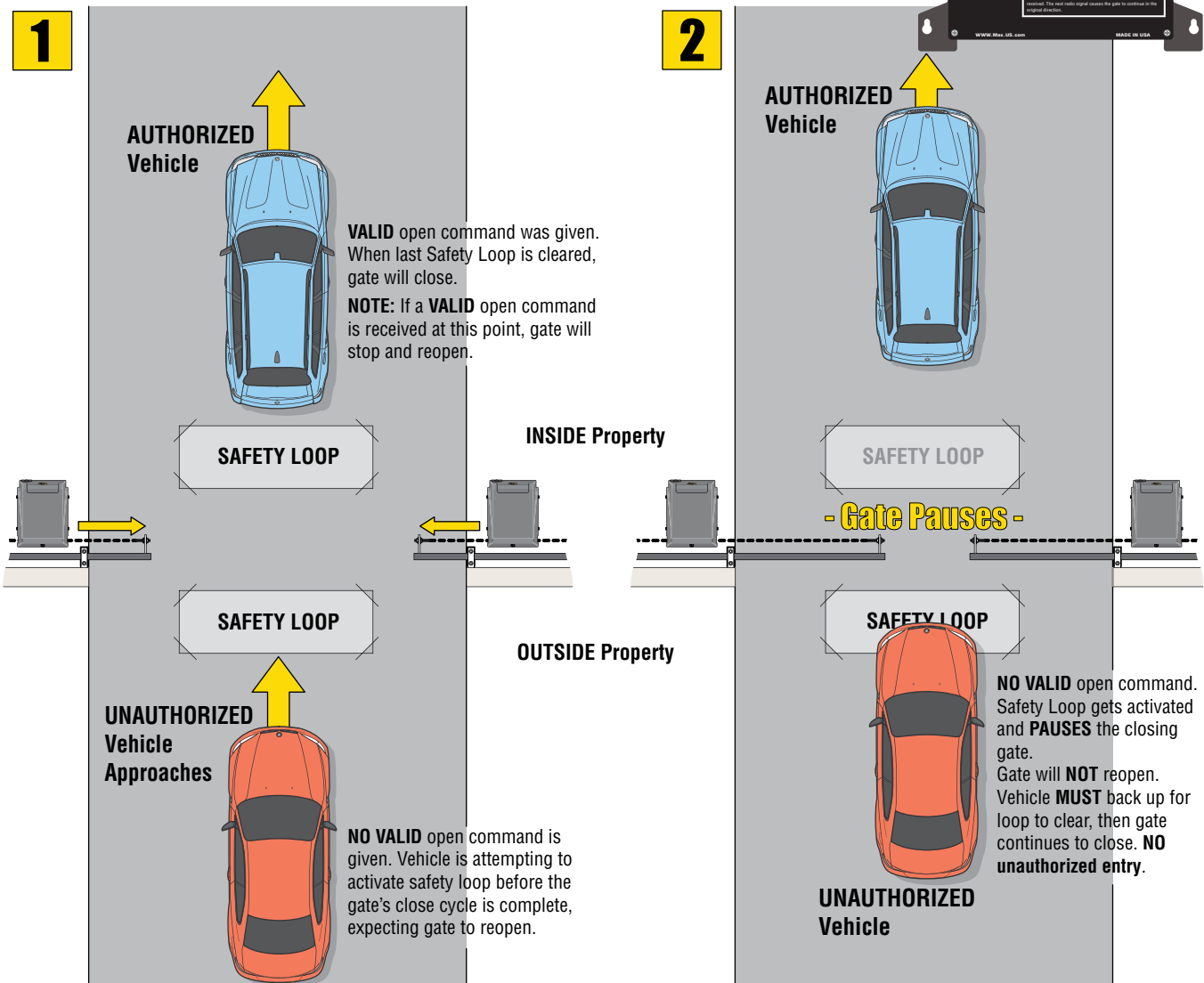
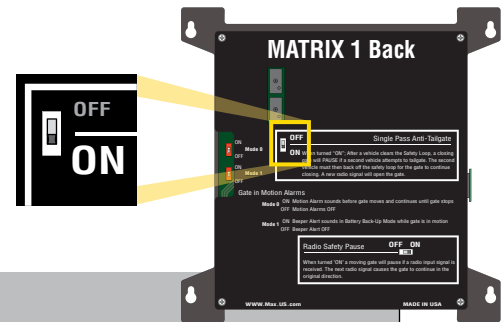



# MATRIX 1

## RADIO RECEIVER

Connect a 3-wire or 4-wire radio receiver to Matrix 1. Choose 12V or 24V, 250 ma max. power.

**CLOSE TIMER ON** - Each time the remote button is pressed **during the Close Timer countdown** (gate is open) causes the timer to reset and begin again. When close timer countdown is complete, gate will close.

**CLOSE TIMER OFF** - Sequence when pressing remote button:

- Press **One Time** - gate **OPENS** . . .
- Press **Again** - gate **STOPS** . . .
- Press **Again** - gate **CLOSES** . . .
- Press **Again** - gate **STOPS** . . .
- Sequence repeats when button is pressed again.

**NOTE:** Signal range is significantly decreased when receiver antenna remains inside operator cover.

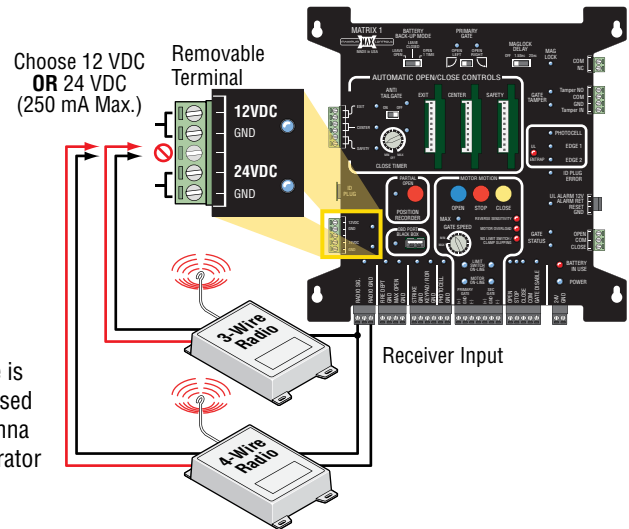

## RADIO SAFETY PAUSE

**Turned ON** - The radio transmitter (remote control) can **PAUSE** a **MOVING** gate by pressing the remote button. Pressing the remote button again will cause the gate to **CONTINUE** in the **SAME** direction. This process can be repeated as many times as desired.

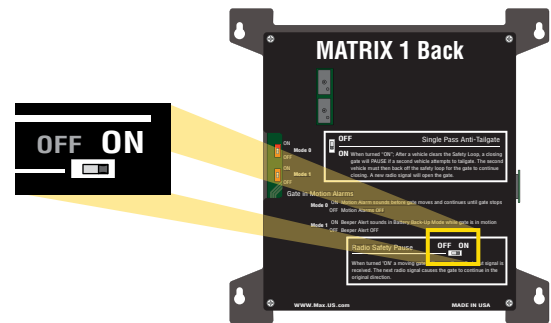

## GATE IN MOTION ALARMS

**MODE 0 - Turned ON** - Alarm will sound **BEFORE** and **DURING** gate cycle to alert surrounding area.

**NOTE:** A strobe light can be connected to **UL ALARM** connection that will flash **ON** and **OFF** when the alarm is sounding. See page 31.

**MODE 1 - Turned ON** - Alarm will beep when using **ONLY** battery power **DURING** gate cycling. This brings to attention that only battery power is being used and **NOT** normal AC power.

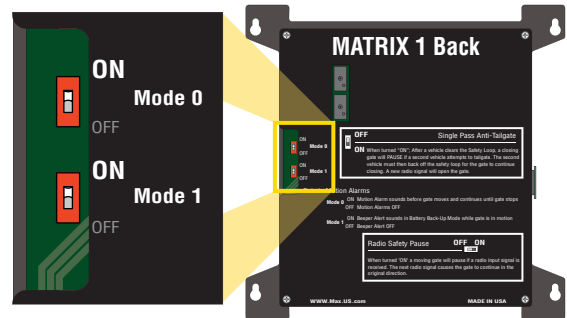

## OBD PORT BLACK BOX

On Board Diagnostics (OBD) port will download a simple .txt file to troubleshoot gate operator errors and to view normal transaction logs. Plug a USB flash drive into port. LED will flash while file is downloading. When LED stops flashing, remove flash drive and plug it into any computer with an available USB port and simple text reader software (ie: notepad, word for PC or textedit for Mac).

The operator's event history is stored as a simple .txt file. Contained in the file is a log of the most recent **1000 events**. Quickly identify and diagnose a complex or intermittent problem. The file can even be e-mailed to the factory for on site diagnosis if necessary. The files will be stored as an ongoing **event history** of the transactions that occur at the gate operator.

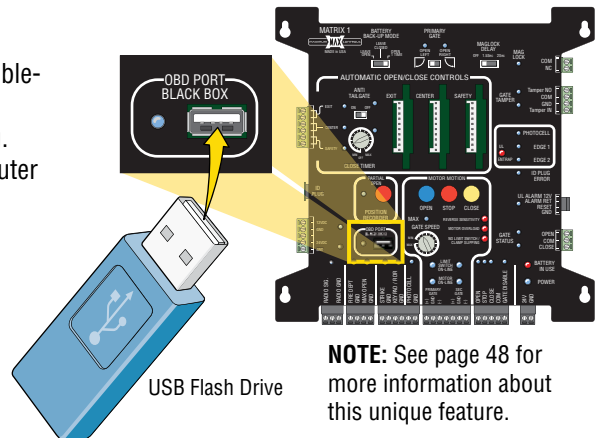

**NOTE:** See page 48 for more information about this unique feature.

# MATRIX 1

## MAGLOCK

Maglock **MUST** be connected as shown.

**MAGLOCK DELAY:** You **MUST** select a time delay when using a maglock.

Maglock power disengages 1.5 sec or 2 sec **before** gate starts opening.

**MAGLOCK LED (Monitors Maglock):**  
**ON** - Locked    **OFF** - Unlocked  
**Flashing** - Problem with Maglock

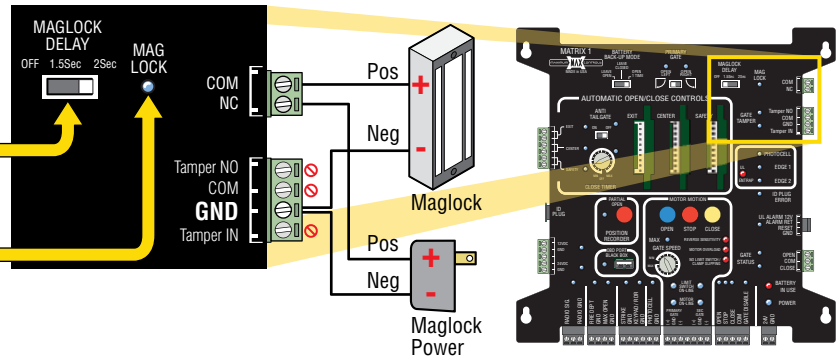

## LOOP DETECTORS

Matrix 1 will accept third party loop detectors in the 2 ports (center loop is **NOT** used). Each loop detector has a corresponding in-ground loop that must be connected for the loop system to operate (see below). Power down Matrix 1 **BEFORE** plugging in loop detectors. Refer to the chosen loop detector instruction manual for more information.

### Plug-In Loop Detectors

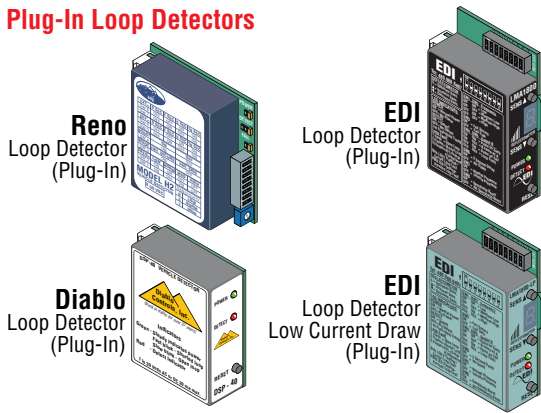

Plug in desired loop detector to appropriate loop port

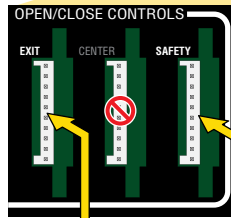

Plug-In Loop Detector

### External Loop Detectors

Third party external loop detectors can be used if desired with the **MAX External Loop Detector Cable Adapter**. (1) One is included with the operator but more can be purchased if needed.

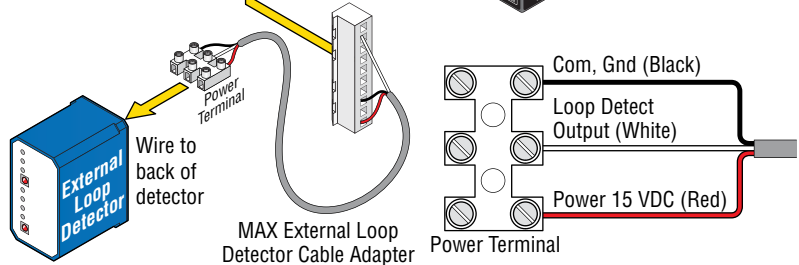

## IN-GROUND LOOP CONNECTION

Connect each in-ground loop wires to the appropriate input. Lead wires should be twisted together 6 twists per foot minimum.

See page 16 for in-ground loop installation.

Safety loop wires must be wired in series.

Each LED will light when the corresponding loop detector get activated by a vehicle passing over its in-ground loop.

LEDs will flash when there is an error with the corresponding loop detector.

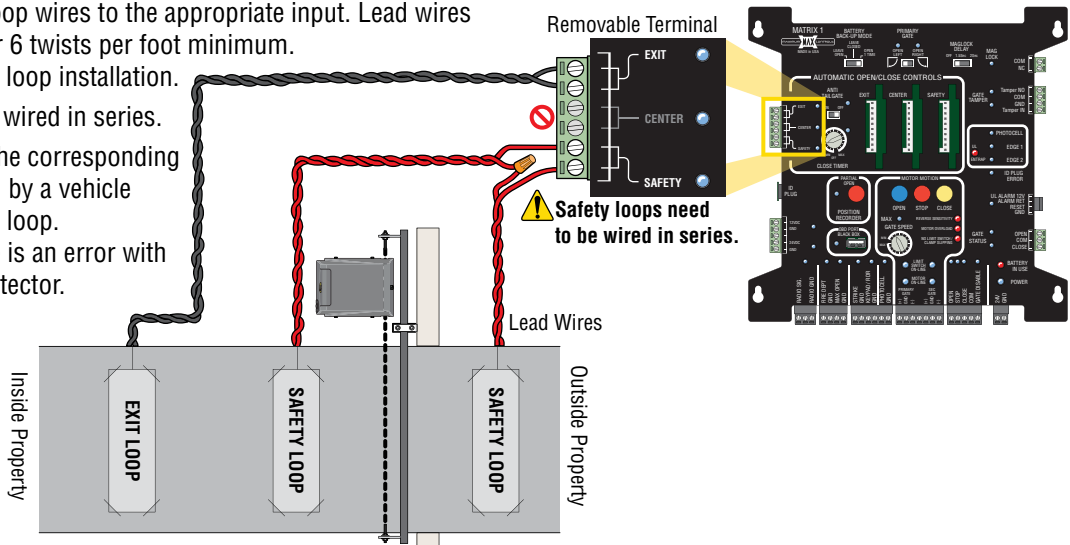

# MATRIX 1

## ID PLUG

AN **ID Plug** comes standard on Matrix 1. It identifies the type of gate operator and **MUST** be plugged in or the Matrix 1 **WILL NOT** function.

**ID PLUG ERROR LED:** Will light when ID PLUG is missing.

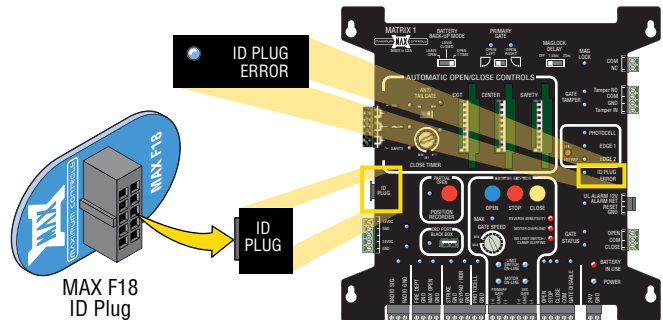

## GATE TAMPER

The **GATE TAMPER** can be used for various functions such as turning a warning light, siren or camera on when the gate is tampered with (Vandalized Gate). The gate operator defines a "Vandalized Gate" as **UNAUTHORIZED** movement of the gate. This can occur if the chain is dropped and gate is manually moved from the **closed position** or the gate is forced open from the **closed position without authorization**.

**TAMPER NO/Com Relay:** Connect a warning light, siren, camera or an existing alarm system to relay.

**TAMPER IN/GND Input:** Connect a sensor device to input. When Tamper In/GND gets triggered, device that is wired to Tamper relay (NO/Com) will activate.

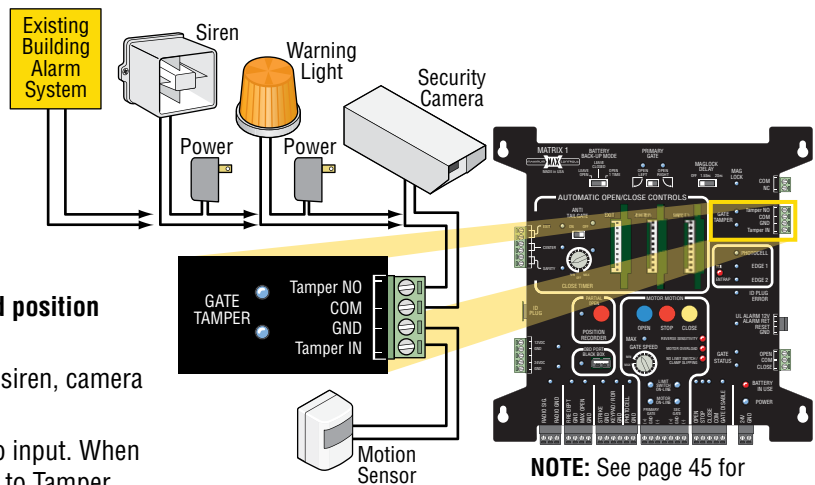

**NOTE:** See page 45 for more information about this unique feature.

## UL ENTRAPMENT LEDS

**UL ENTRAPMENT LEDS** will indicate when a **OPENING DIRECTION** Photocell and/or Sensing Edge(s) have been activated. If alarm gets triggered, press reset button on side of operator to turn alarm off.

**NOTE:** **UL safety approved devices** are wired to the MC-200 motor controllers **ONLY**. DO NOT wire them to the Matrix 1.

**REVERSE SENSITIVITY LED:** Will light when the gate encounters an obstruction triggering the ERD sensor.

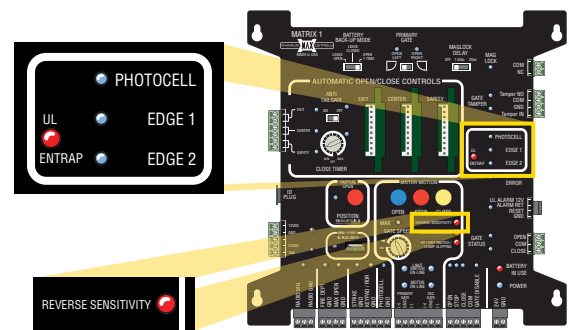

## EMERGENCY VEHICLE/MAX OPEN INPUTS

**FIRE DEPT Input:** Should be connected to a knox box device to allow the proper authorities to gain emergency access when necessary. The input will override the **GATE DISABLE** input and allow **EMERGENCY** personnel **FULL 24/7** access. Gate **FULLY** opens.

**MAX OPEN Input:** Can be connected to a key switch and used as an **ADDITIONAL** input from the FIRE DEPT input. The input will override the **GATE DISABLE** input and allow **SECURITY** personnel **FULL 24/7** access. Gate **FULLY** opens.

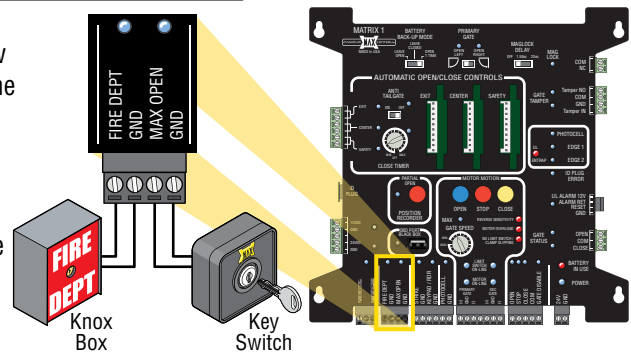



# MATRIX 1

## GATE DISABLE

An ON/OFF switch or 7-Day timer devices can be connected to the **GATE DISABLE** input. When these devices are turned ON, they will **DISABLE** normal opening devices such as keypad, exit loop etc. The **FIRE DEPT/ MAX OPEN** and **RADIO** inputs will remain enabled when **GATE DISABLE** has been turned ON. This is useful when the gated area needs to be secured from ALL but emergency or authorized vehicle entry. Some examples are: Residential home vacation period or during closed hours of a business when no one can monitor the property.

**When GATE DISABLE is turned ON:** The operator will beep for **3 minutes BEFORE arming itself**. This allows time to turn ON **GATE DISABLE** and leave the property before it is armed.

**When FIRE DEPT/MAX OPEN gets activated:** Gate opens and **GATE TAMPER** relay will activate immediately.

**When RADIO Input gets activated:** Gate opens and **GATE TAMPER** relay will activate **after 3 min**. This allows time to turn OFF **GATE DISABLE** or disarm an existing building alarm system if connected.

**IMPORTANT:** It is **NOT** recommended activating the **GATE DISABLE** device while persons are present inside the property.

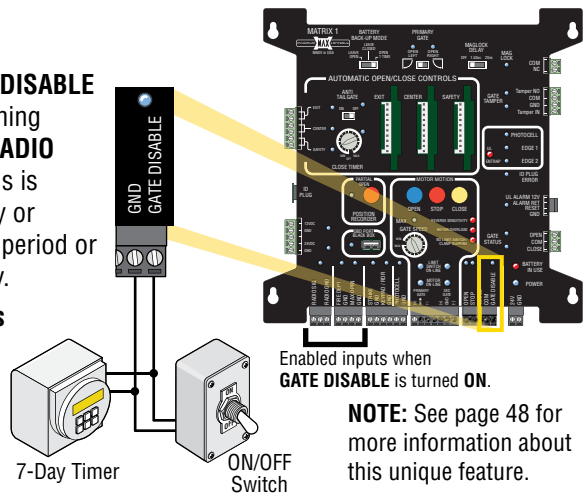

## PARTIAL OPEN

A gate can set to partially open by recording the **PARTIAL OPEN** gate cycle. LED will stay lit when **PARTIAL OPEN** is ON. The gate **MUST** open a minimum of **6 ft for a single vehicular gate** and **10 ft for dual vehicular gates**. If the opening distance you record is less than the minimum allowed, the operator will beep, NO recording will register and the LED will turn **OFF**. Retry recording with a greater opening distance. LED remains **ON** when recording is successful.

**IMPORTANT:** Limit sensor activators **MUST** be **learned BEFORE** Partial Open can be recorded.

### To RECORD PARTIAL OPEN:

1. With gate in **CLOSED** position, press and release **PARTIAL OPEN** button to START recording. Blue LED **starts** flashing.
2. Press Motor Motion **OPEN** button to start gate's open cycle.
3. Press Motor Motion **STOP** button when gate gets to desired partial open position.
4. Press **PARTIAL OPEN** button **AGAIN** to STOP recording. LED **stops** flashing, open position has been successfully recorded. LED remains **ON**.

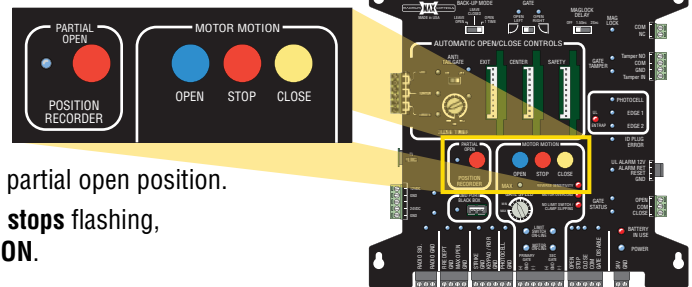

### To ERASE PARTIAL OPEN recording:

Press and **HOLD PARTIAL OPEN** button for 5 sec. Blue LED turns **OFF**.

**NOTE:** The **FIRE DEPT** and/or **MAX OPEN** connected devices will always **FULLY** open gates even when the partial open is being used.

## UL ALARM WARNING LIGHT INPUT

A **UL ALARM** (strobe light) can be connected. It will turn **ON** when the **GATE IN MOTION - Mode 0 and/or Mode 1** are turned **ON** (see page 28).

Press **ALARM RESET BUTTON** to turn **OFF** activated strobe light.

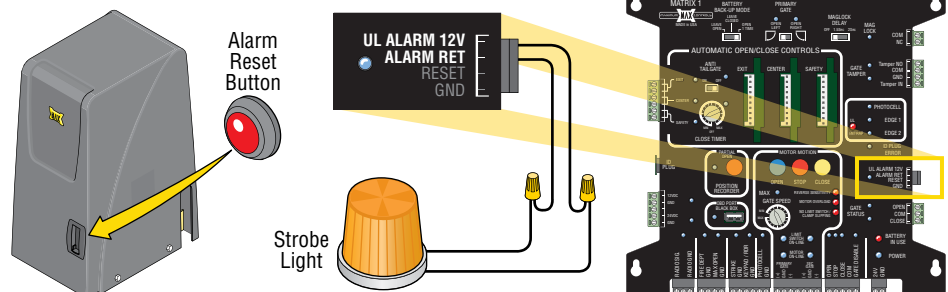

# MATRIX 1

## GATE STATUS MONITORING

**GATE STATUS** LEDs will turn **ON** when gate is in the **OPEN** or **CLOSED** position.

Connect a gate monitoring device to **GATE STATUS** relays to show if gate is in the OPEN or CLOSED position.

**OPEN/COM Relay:** Activates momentarily (1 sec) when gate gets to the OPEN position.

**CLOSE/COM Relay:** Activates when gate gets to the CLOSED position.

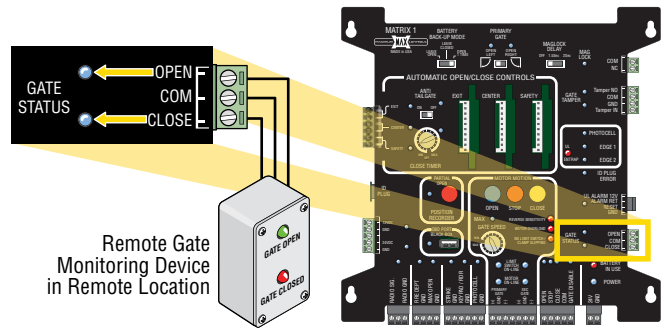

## OPEN / STOP / CLOSE CONNECTION

The **OPEN/STOP/CLOSE** inputs will allow a standard 4-wire **3-Button Station** or an additional **External RESET Button** to be connected. Corresponding LEDs will light when each button is activated.

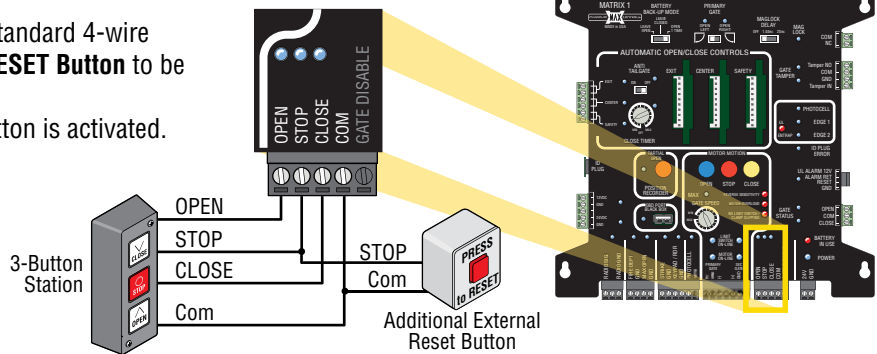

## CLOSING PHOTOCELL CONNECTION

The **PHOTOCELL** input will allow a **CLOSING DIRECTION PHOTOCELL** to be connected. 12V or 24V power can be supplied for the photocells.

**NOTE:** This input is **NOT UL SAFETY PHOTOCELL**. **ALL UL inputs MUST be made at the MAX MC-200 motor controller on the gate operator.**

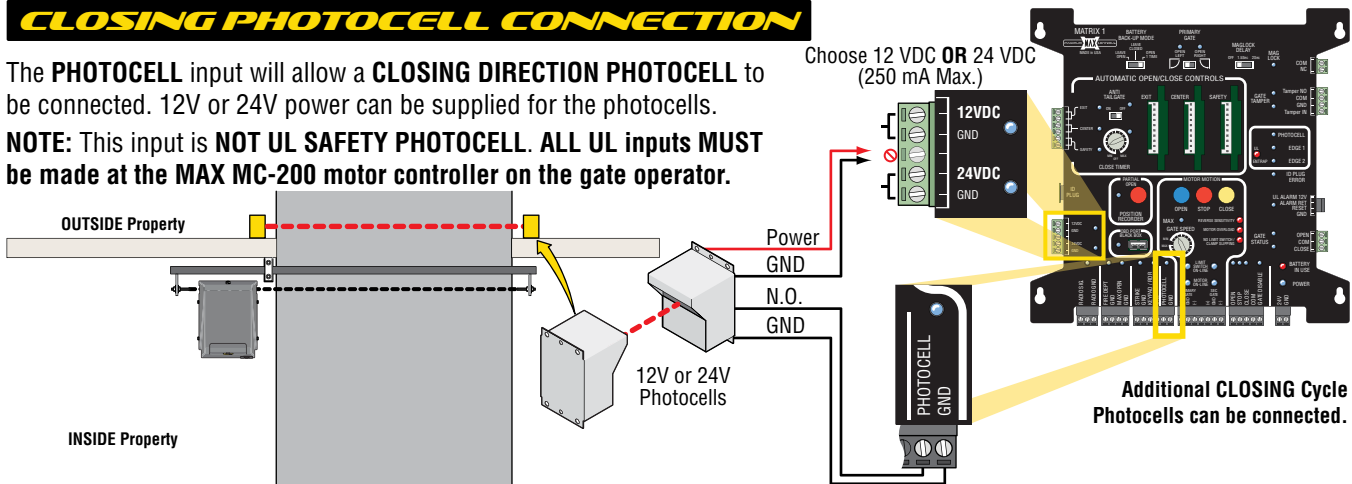

## MOTOR MOTION LEDs

**REVERSE SENSITIVITY LED:** Will light when the gate encounters an obstruction triggering the ERD sensor.

**MOTOR OVERLOAD LED:** Will light when excessive current is being drawn by motor caused by damaged gate hardware or gate is too heavy.

**NO LIMIT SWITCH/CLAMP SLIPPING LED:** Will light when either limit sensor does NOT activate from it's learned positions.

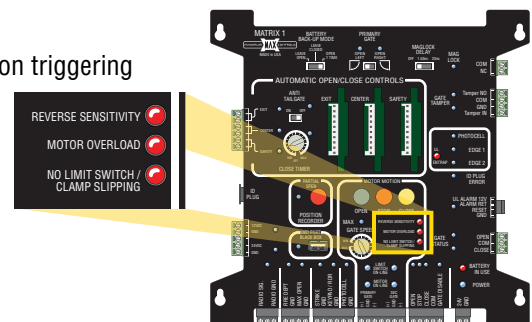

# MATRIX 1

## GATE OPERATORS COMMUNICATION LEDS

**PRIMARY/SINGLE** operator's MC-200 has been wired to the **PRIMARY GATE (Factory Wired)**.

**SECONDARY** operator's MC-200 gets connected to the **SEC GATE (+, GND, -)**. See page 22.

**LIMIT SWITCH ON-LINE LEDS:** will light for each gate operator's **limit switch** that the **Matrix 1** is successfully communicating with.

**MOTOR ON-LINE LEDS:** will light for each gate operator's **MC-200 Motor Controller** that the **Matrix 1** is successfully communicating with.

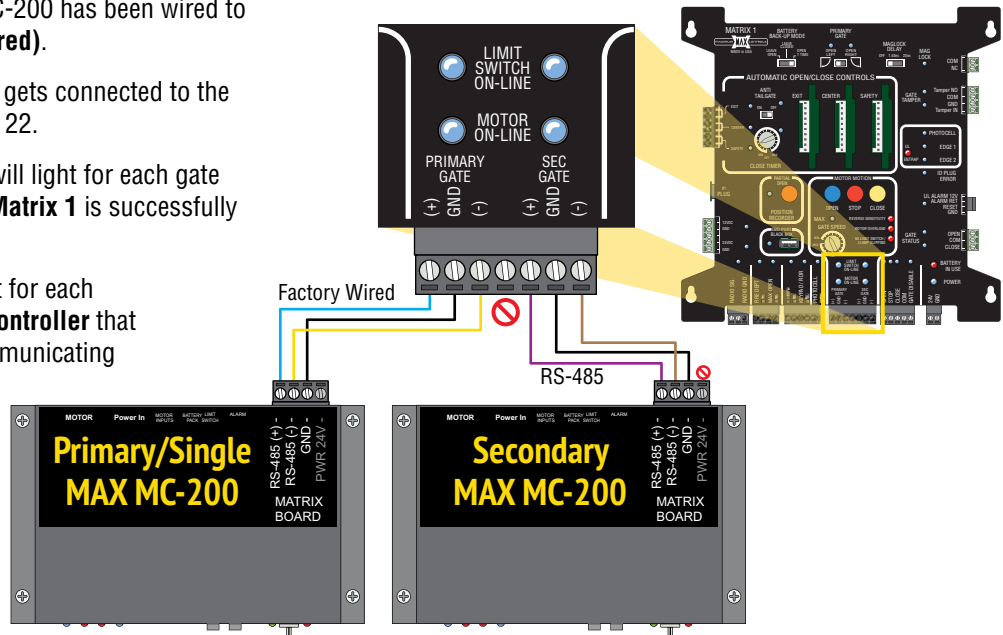

## 24V POWER FOR MATRIX 1

**24VDC POWER** from **PRIMARY/SINGLE** operator **ONLY**.

**POWER LED:** Will light when 24V low voltage power is connected.

**NOTE: DO NOT** power external devices using this connection. This power is reserved for Matrix 1 and UL opening cycle entrapment photocells **ONLY**.

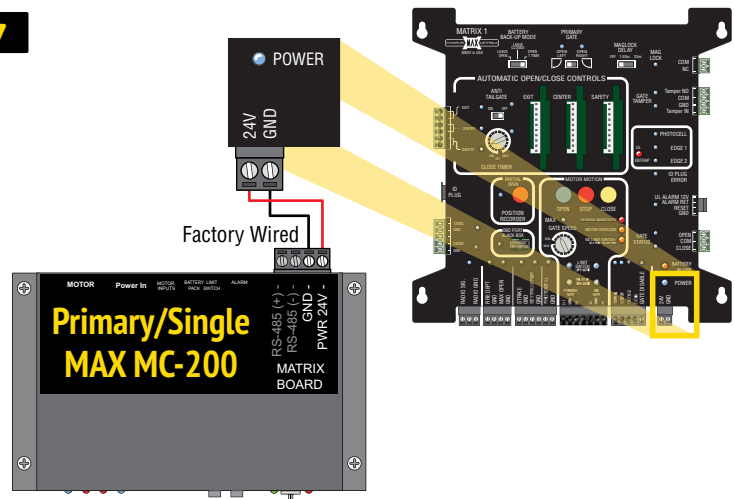

## BATTERY IN USE LED

**BATTERY IN USE LED** will light when operator is using **ONLY** battery back-up power. The **GATE IN MOTION Alarm** can be set up to sound alarm when operator is using **ONLY** battery power **DURING** gate cycling. This brings to attention that only battery power is being used and **NOT** normal AC power. See page 28.

**LED Flashing NOTE: BATTERY IN USE** and **POWER** LEDs flash together when the battery is not plugged into the BATTERY IN port of the MAX BC-7 Battery Module. Make sure battery plug is correctly installed and there is no damaged or loose wires.

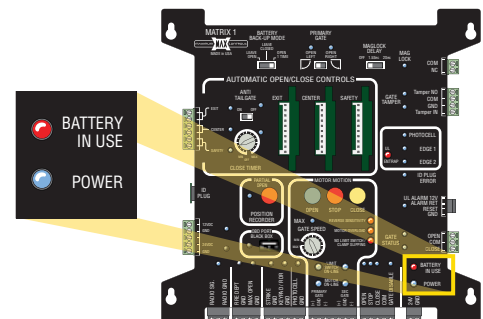

# MATRIX 1

## GATE SHUT-OFF SWITCH

This factory installed switch will disable the normal opening devices when turned **ON**, such as keypad, exit loop etc. Only the **Jog Left** or **Jog Right** buttons on the MAX MC-200 motor controller will operate gate when Gate Shut-Off switch is **ON**.

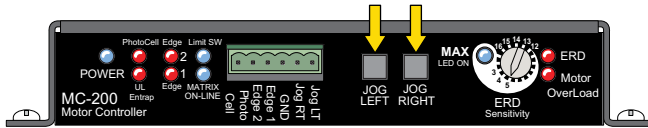

MAX MC-200 motor controller

This feature is useful when the gate operator is being serviced. The gate operator can not accidentally get activated while this switch is ON.

**IMPORTANT:** When the Gate Shut-Off switch is turned **ON**, operator will be disabled and it will “**BEEP**” for a few seconds to indicate that Gate Shut-Off switch is ON.

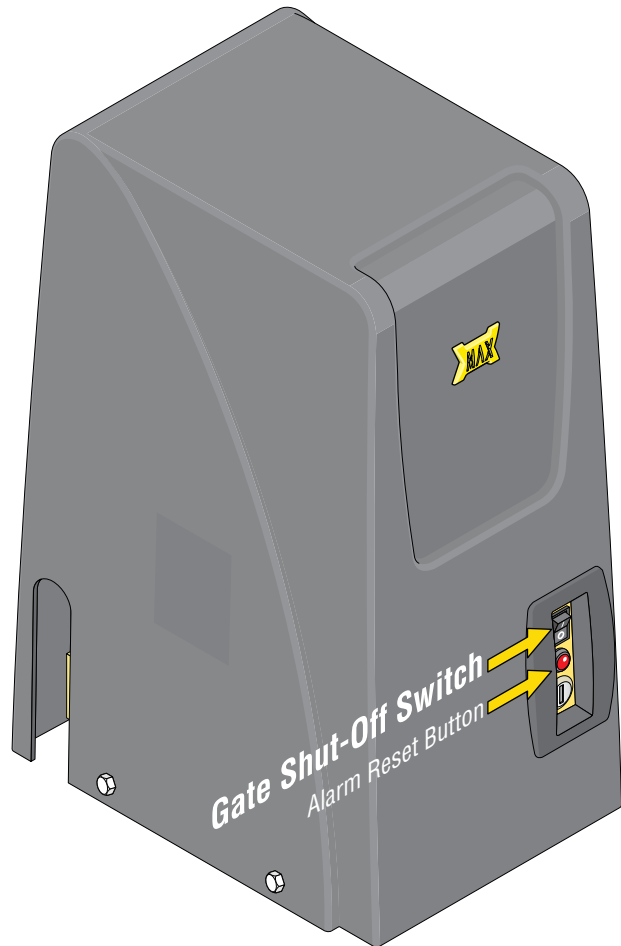

## Dropping the Chain

If an existing alarm system (Building alarm system) is connected to the **GATE TAMPER** relay, notify proper authorities **BEFORE** dropping the chain.

### PROPER Dropping of Chain (Normal Operator Servicing):

1. Turn Gate Shut-Off switch **ON** to disable operator alarm.
2. Drop the Chain.
3. **GATE TAMPER** relay **WILL** be activated.
4. Service operator.
5. Reconnect the chain to gate.
5. Turn Gate Shut-Off switch **OFF**.
6. Rearm an alarm system that may be connected to the **GATE TAMPER** relay.

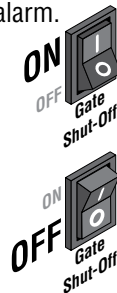

### IMPROPER Dropping of Chain (Vandalize):

Gate Shut-Off switch is **NOT** turned **ON**.  
When the chain is improperly dropped (Vandalized), the **OPERATOR ALARM** and **GATE TAMPER** relay will activate. The operator will shut down all operating functions. The alarm reset button **MUST** be pressed to turn **OFF** the alarm and reset the operator. If **GATE TAMPER** relay is connected to an existing building alarm system, then they will get a triggering of their alarm system and should be notified of the situation.

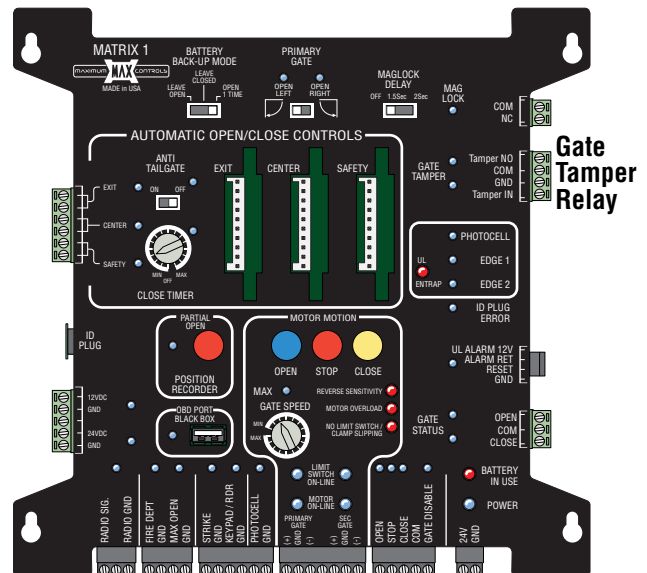

# MATRIX 1

## EXTERNAL OPEN/CLOSE KEY SWITCH - OPTIONAL

An Optional **External Open/Close Key Switch** can be connected that allows **dual gate operators** to be **electronically moved** open or closed at the same time by wiring both operators to the external key switch.

Connect (3) three wires from each **MAX MC-200 Motor Controllers** to an **External Open/Close Key Switch** depending on your specific installation, see below.

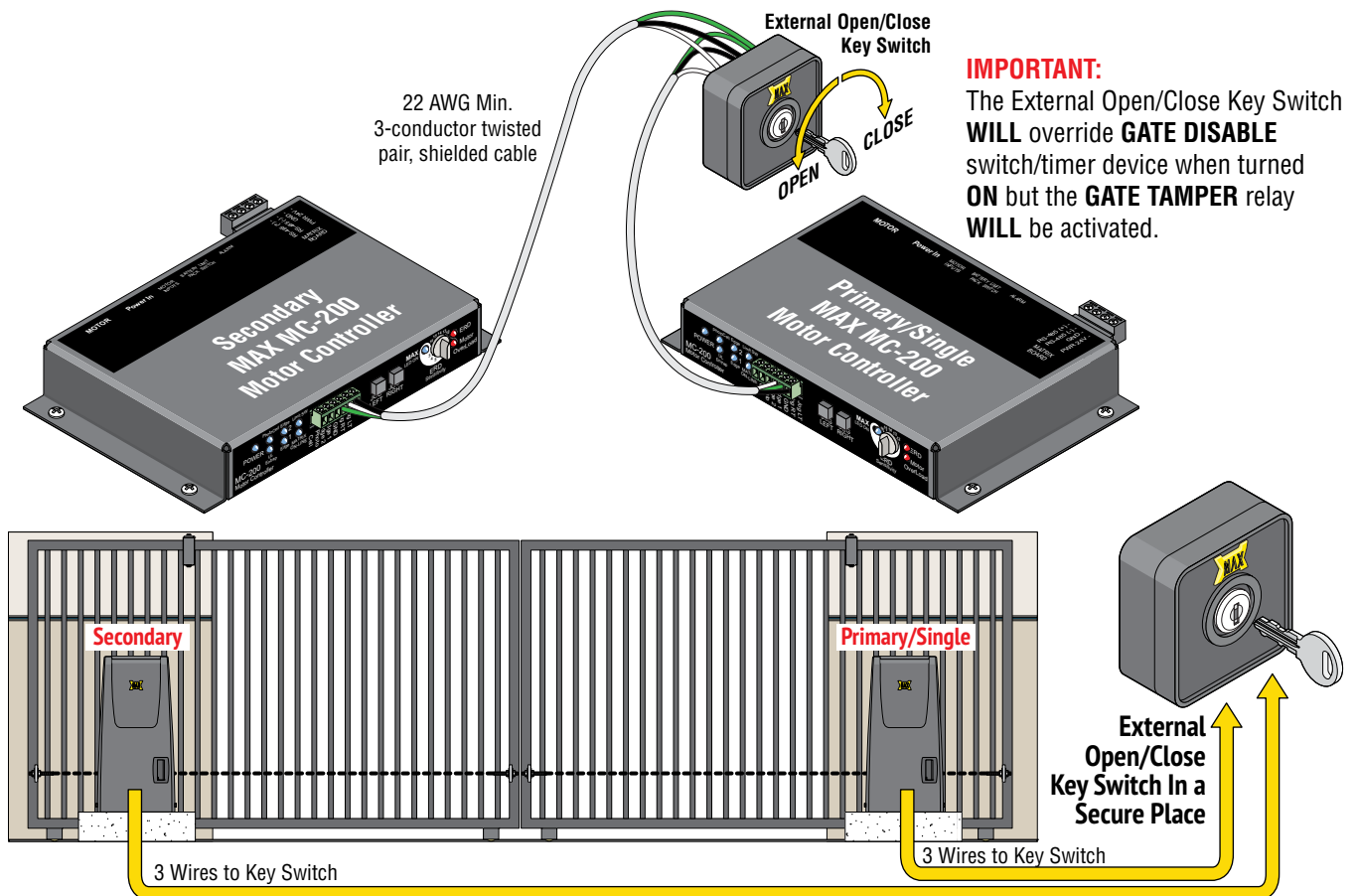
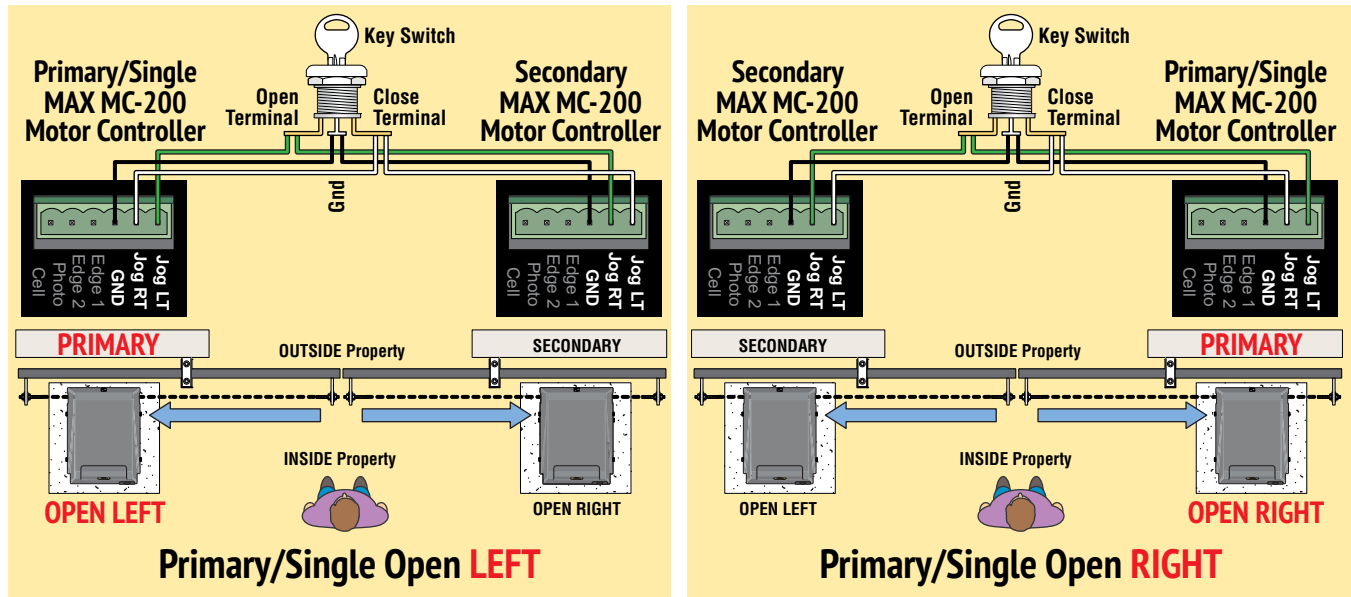



# ADJUSTMENTS

## OPEN AND CLOSE LIMITS

The limit sensor activators **MUST** be installed on **BOTH** ends of chain to indicate the **OPEN** and **CLOSE** positions of the gate or **DAMAGE** will occur. They will activate the corresponding **LIMIT SENSOR** (Gray or Black) when they move within range, stopping the gate at the desired positions.

The limit sensors have been **FACTORY INSTALLED** for front mounting position. If rear mounting position is being installed, make sure the limit sensors have been moved to the correct positions (see below).

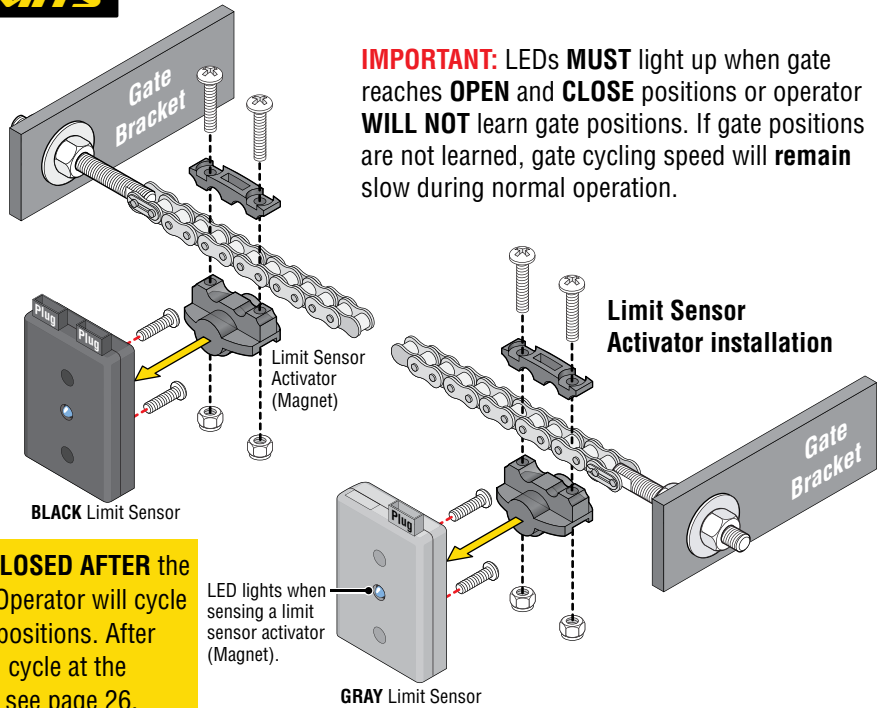

**IMPORTANT:** LEDs **MUST** light up when gate reaches **OPEN** and **CLOSE** positions or operator **WILL NOT** learn gate positions. If gate positions are not learned, gate cycling speed will **remain** slow during normal operation.

**IMPORTANT:** Cycle the gate **OPEN** and **CLOSED** AFTER the limit sensor activators have been installed. Operator will cycle slowly to **LEARN** the **open** and **closed** gate positions. After the operator learns the gate positions, it will cycle at the **GATE SPEED** selected for normal operation, see page 26.

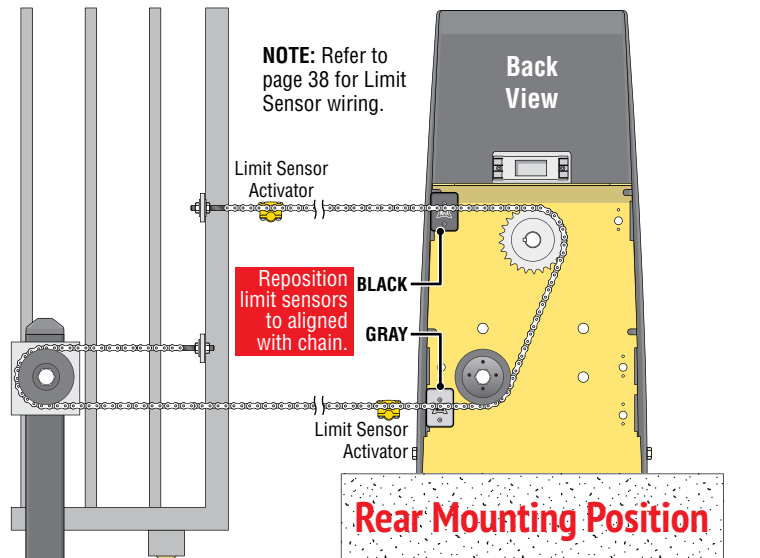
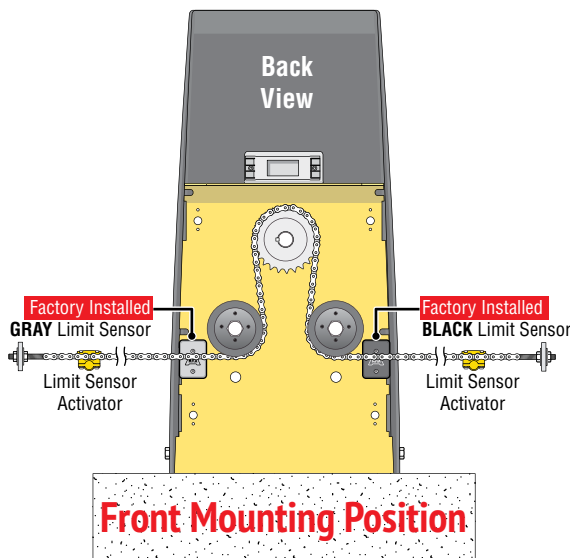

### “Fine Tune” Limits Adjustment

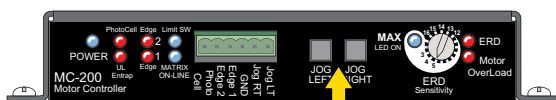

Push and **HOLD** the **JOG LEFT** or **JOG RIGHT** buttons accordingly on the **MAX MC-200** motor controller to move the gate (release the button to stop gate). This allows gate to be moved back and fourth without leaving the operator to “fine tune” the open and close gate positions if desired.

**WARNING:** Avoid moving gate while “Fine Tune” adjusting.

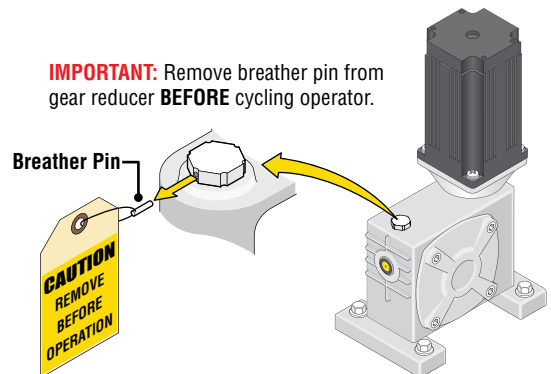

**IMPORTANT:** Remove breather pin from gear reducer **BEFORE** cycling operator.

# ADJUSTMENTS

## REVERSE SENSOR (ERD)

The MAX F18 is equipped with an **ERD Sensor - Electronic Reversing Device** (Type A) that functions as the primary entrapment protection according to UL 325 standards. **The gate will reverse direction after encountering an obstruction in either the OPEN or CLOSE gate cycle.**

When the gate encounters an obstruction during the **CLOSE** cycle, it will reverse to the open position and **PAUSE** the gate. An input command (press remote button or exit loop activation) is needed **BEFORE** the gate will reset and close again.

When the gate encounters an obstruction during the **OPEN** cycle, it will reverse approximately 6 inches and **PAUSE** the gate. An input command (press remote button or exit loop activation) is needed **BEFORE** the gate will reset and open again.

For the **ERD Sensitivity** to function correctly:

- Limit sensors **MUST** be learned **BEFORE** adjusting the ERD Sensitivity. See previous page if you have questions about how limit sensors are learned.

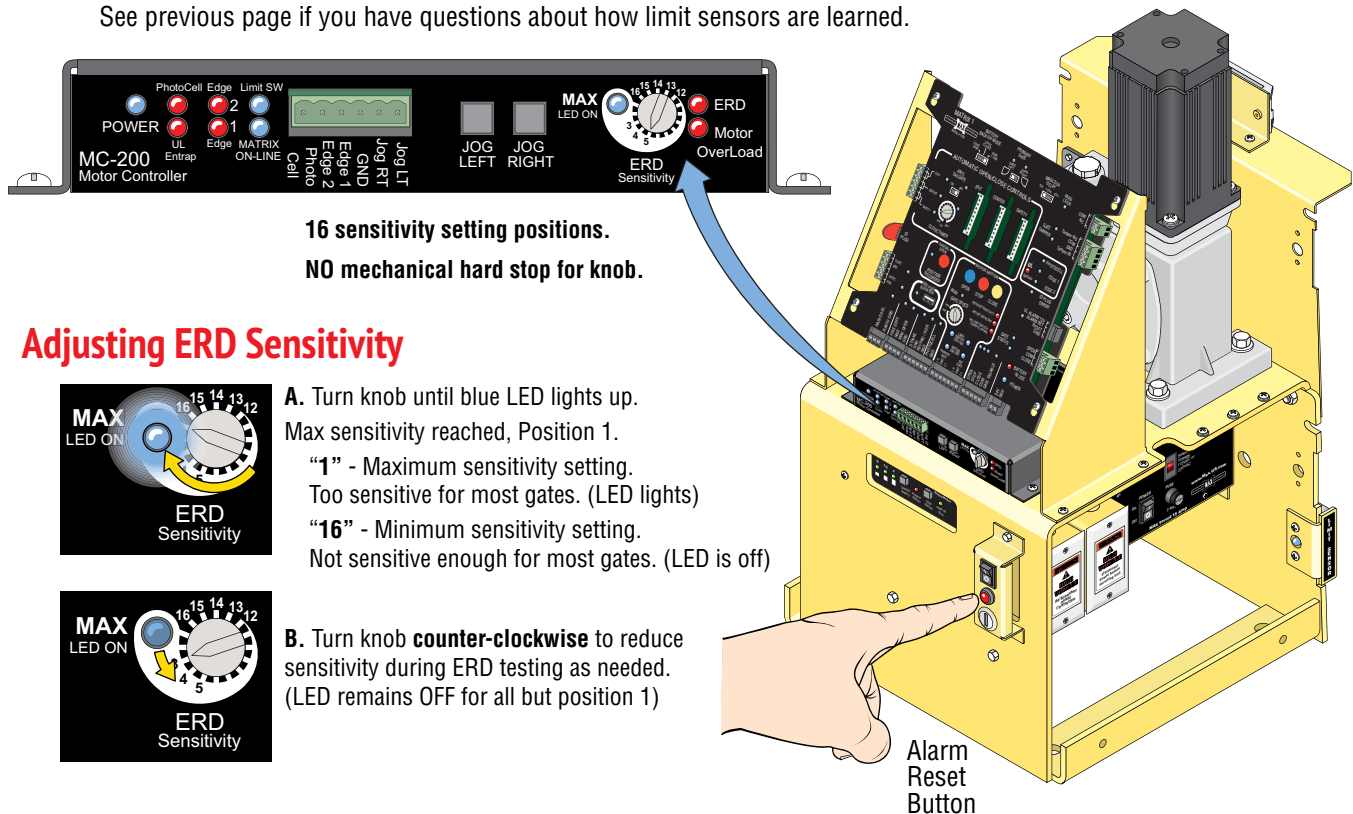

## Testing ERD Sensitivity

Allow the gate to strike an immobile object while **OPENING** and **CLOSING**. The gate **MUST** reverse direction after striking the object. Increase or decrease the **ERD Sensitivity** as needed. Repeat this process until the correct sensitivity is achieved. If alarm sounds while performing this procedure, press alarm reset button on operator to shut off alarm.

**IMPORTANT:** When satisfied with ERD adjustment, cycle the gate 3 or 4 times to make sure that the ERD sensor does not **falsely trigger** during normal gate operation. Readjust if this happens.

**NOTE:** When solid gates are installed in **unusually high wind areas**, ERD sensor can be set to **Min** (position 16) to keep the gate cycling normally in such extreme conditions.

**CAUTION:** Minimum sensitivity setting (position 16) results in gate exerting **MAXIMUM force** before reversing direction.

# MAINTENANCE

## MAX F18 PRIMARY/SINGLE WIRING SCHEMATIC

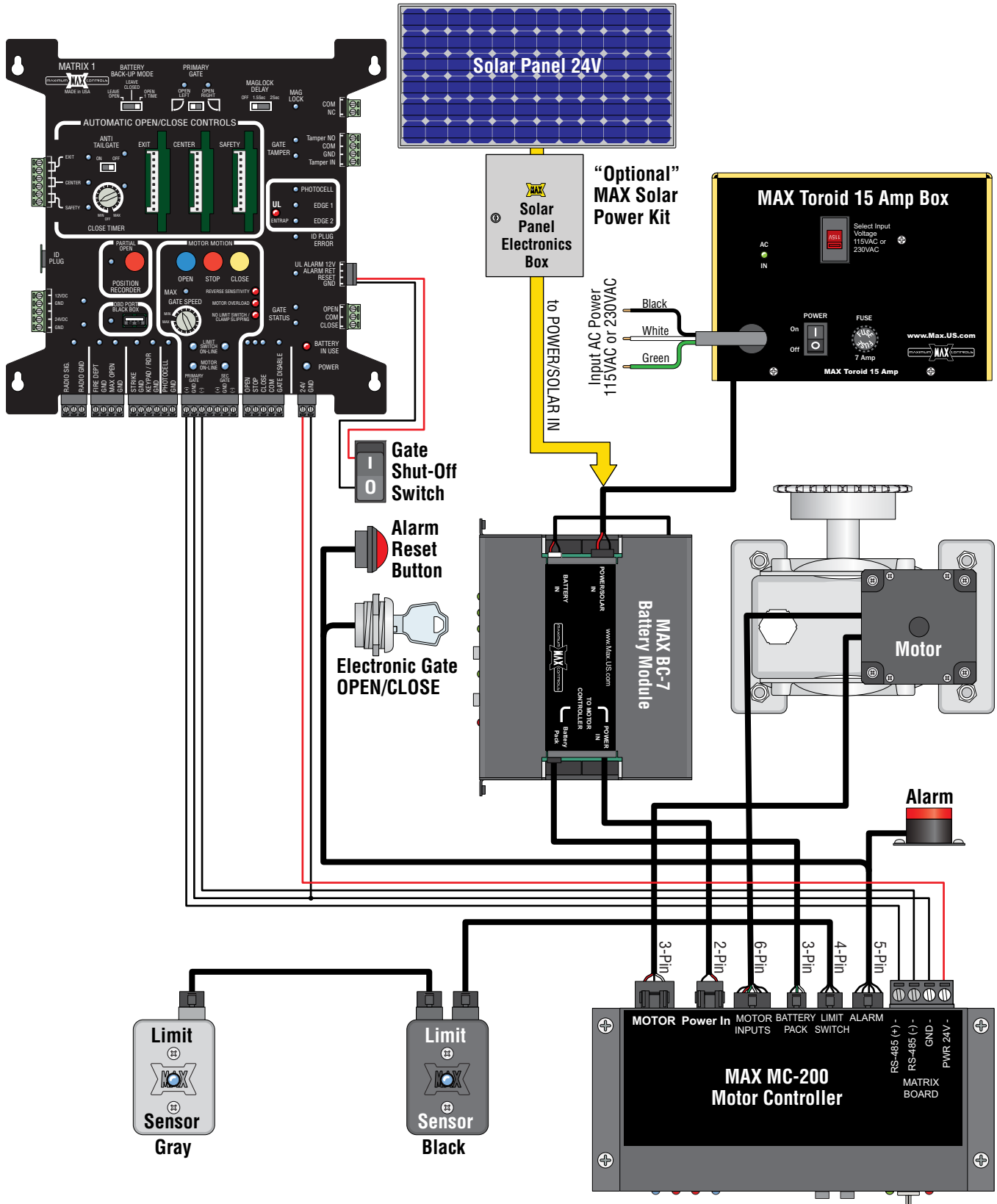



# MAINTENANCE

## MAX F18 SECONDARY WIRING SCHEMATIC

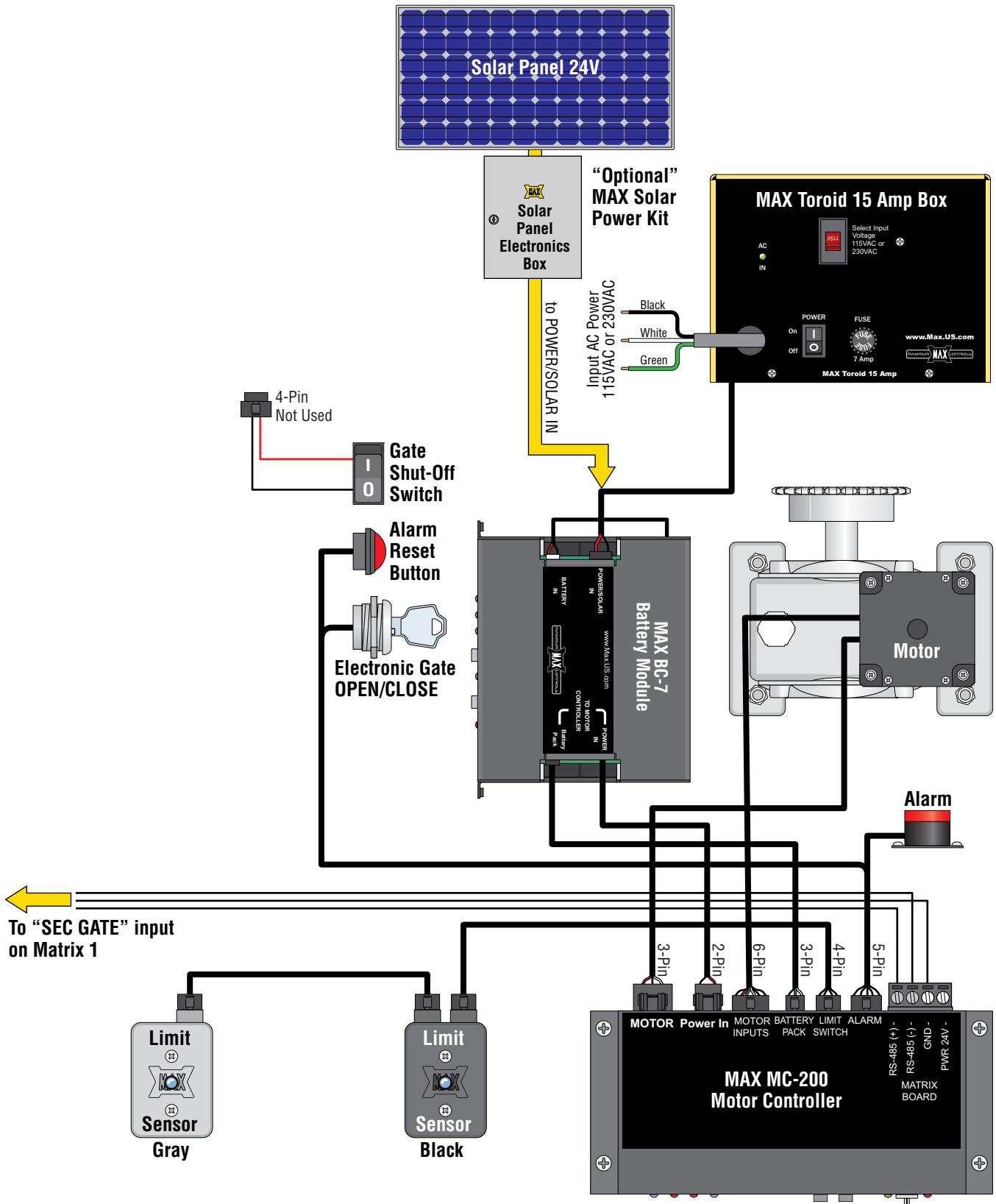

# MAINTENANCE

## **QUALIFIED GATE OPERATOR TECHNICIAN**

Maintenance and repair of the gate operator must be performed by a qualified professional gate operator technician.

The following services need to be periodically performed:

- Turn **ON** the **Gate Shut-Off Switch BEFORE** performing any maintenance.
- Check and adjust the gate operator's force, speed, and sensitivity.
- Make sure all power (AC/DC) connections are corrosion free.
- Check all batteries for proper voltage.
- Check the incoming line voltage and confirm it is within 10% of its rating (115 or 230 volts).
- Verify battery backup functionality by turning off the power source (115 VAC and 230 VAC). Restore power after testing.
- Check that chain is not too loose and remove chain links if necessary. DO NOT make chain too tight.
- Check wheels, guide rollers and chain and lubricate with heavy-duty, high-performance lubricant where needed.
- Check V rail for signs of cracking or separation from ground.
- Test all contact and non-contact sensors, in-ground vehicle loop detectors, keypad, telephone entry system or any other access control devices that are used to control the gate operator.
- Test the manual release feature.

**MAKE SURE END USER/HOME OWNER KNOWS HOW TO PROPERLY REMOVE GATE OPERATOR FROM SERVICE AND WHO TO CONTACT FOR PROFESSIONAL ASSISTANCE.**

Date Installed: \_\_\_\_\_

Installer/Company Name: \_\_\_\_\_

\_\_\_\_\_

Phone Number: \_\_\_\_\_

Operator

Serial Number: \_\_\_\_\_

## **END USER / HOMEOWNER**

Any repairs and modifications must be performed by a qualified professional gate operator technician. If the gate or gate operator ever malfunctions, end user/home owner needs to immediately remove the gate operator from service (manually position gate (see manual release) in a desired prolonged position and turn ALL power OFF to the gate operator). End user/home owner must call a qualified professional gate operator technician for any repairs and modifications.

The gate operator is virtually maintenance free to an end user/home owner, minimal maintenance is recommended to ensure reliable operation.

End user/home owner:

- Scheduled maintenance should be performed approximately every six months by a qualified professional gate operator technician, or when unusual noises are heard from the wheels, chain, guide rollers and/or gate operator.
- DO NOT remove the operator cover to perform any normal maintenance.
- Lubricate wheels, chain, guide rollers periodically with heavy-duty, high-performance lubricant and clean up all excess lubricant.
- Make sure there are no vehicles or pedestrians in the path of the gate while performing maintenance.
- Make sure the person performing maintenance is the only person in control of all control devices in order to avoid possible involuntary activation of the gate operator. Gate operator MUST be removed from service while maintenance is performed.
- Keep any water from landscape watering hoses or sprinkler systems away from the gate and gate operator area.
- Keep the area around the gate and gate operator as clean as possible.
- Keep any debris away from the gate's moving path.
- Test periodically (use caution) all safety sensors, in-ground vehicle loop detectors, keypad, telephone entry system or any other access control devices that are used to control the gate operator. Make sure everything is working properly.
- Solar panel must be cleaned periodically if solar power is being used.

# MAINTENANCE

## ELECTRONIC GATE OPEN / CLOSE

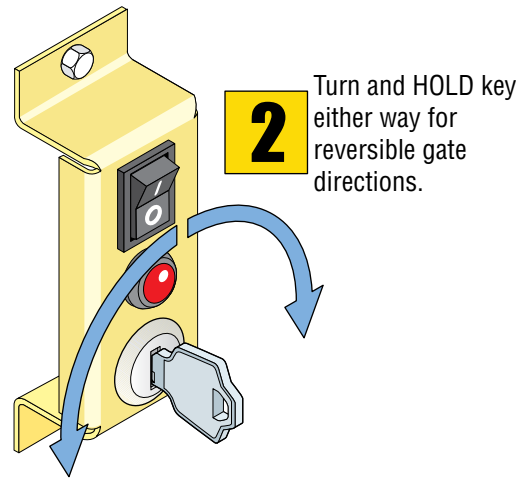
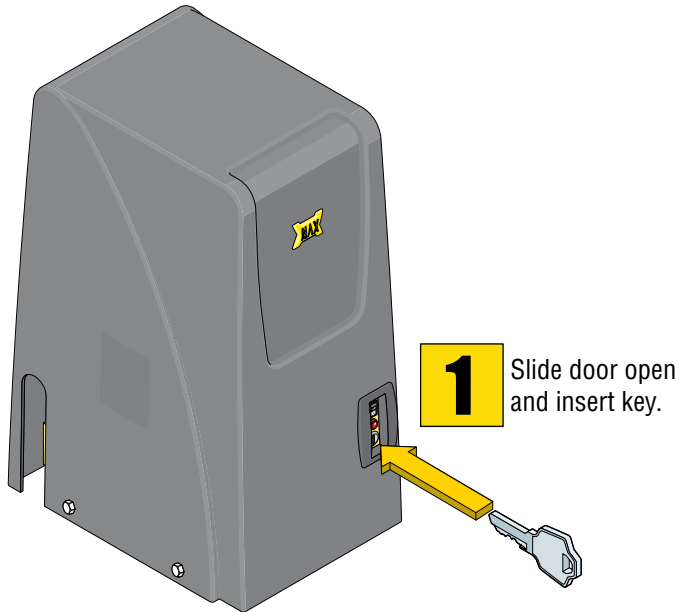

**CAUTION:** Keep pedestrians and vehicles clear of the gate while it is moving.

**NOTE:** The gate cannot be manually pushed open.

## MECHANICAL GATE RELEASE (MANUAL RELEASE)

The chain is mechanically dropped to manually release the gate. The **GATE SHUT-OFF SWITCH MUST** be turned **ON** before dropping the chain (See **1** below). **Dropping the chain without turning the Gate Shut-Off switch ON will activate the ALARM and GATE TAMPER feature**, See page 34 for complete information about Gate Shut-Off switch operation.



### Optional MAX Chain Release

Perform **1**.

Insert key and turn to unlock chain.

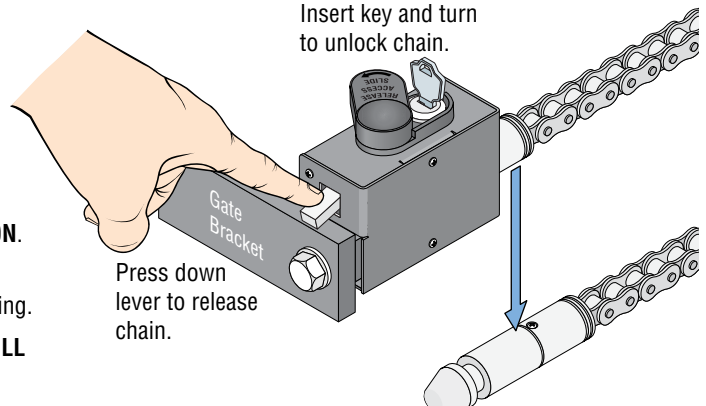

See page 49 for more information about MAX chain drop mechanism.

# MAINTENANCE

## AUDIBLE ALARM

**If the Alarm Sounds During Normal Gate Operation:** When the gate encounters **TWO** consecutive obstructions before completing a gate cycle, the alarm will sound and the gate will **PAUSE** in the position where the second obstruction occurred. **CHECK THE GATE AREA FOR ANY PROBLEMS BEFORE** pressing the alarm reset button on the operator to shut off the alarm and reset the gate. **NOTE:** Alarm will automatically shut-off after five minutes but **will not allow** gate to operate until the **alarm reset button** is pressed.

### Some reasons why the alarm sounds:

- A **FOREIGN OBJECT** is on the gate frame while the gate is moving.

- The gate is **TOO HEAVY**.

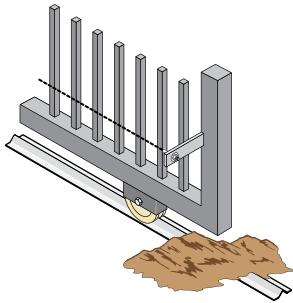

- **Debris** is on the gate rail such as mud, rocks dirt etc. and gate **CANNOT** move freely.

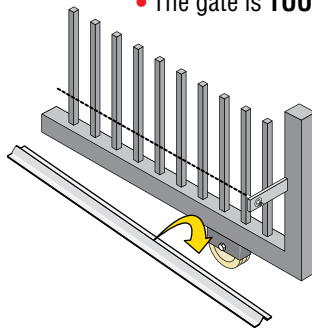

- **WHEELS** are **NOT ON GATE RAIL** and gate **CANNOT** move freely.

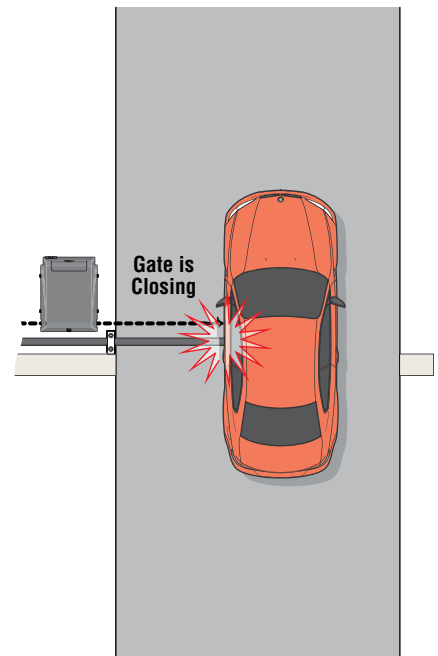

- The gate is **HITTING** a **VEHICLE**.

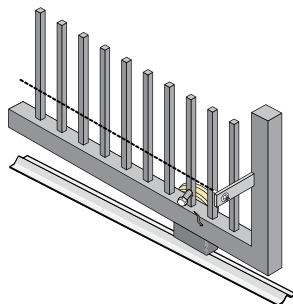

- **WHEELS** are **BROKEN** and gate **CANNOT** move freely.

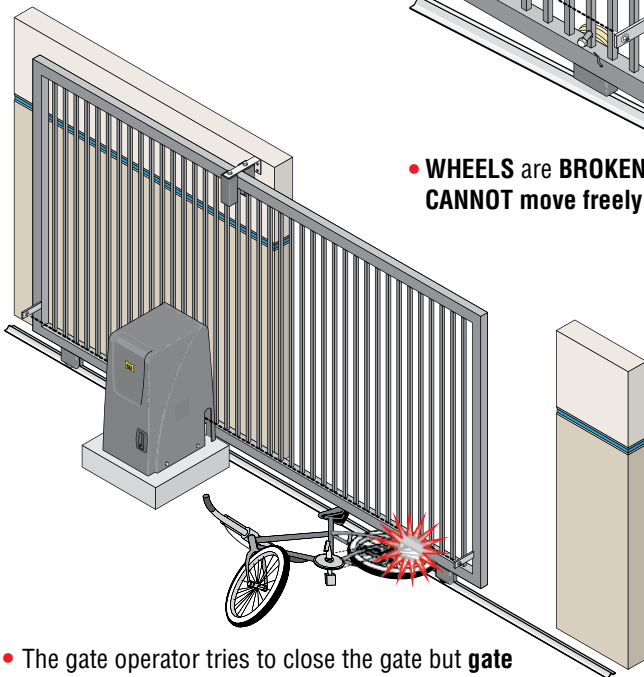

- The gate operator tries to close the gate but **gate gets CAUGHT** on an object and cannot complete a gate cycle.

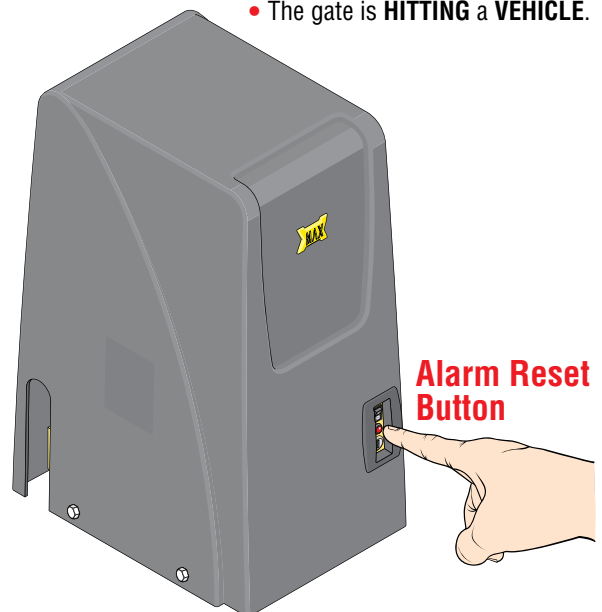

**Alarm Reset Button**

# MAINTENANCE

## REPLACEMENT PARTS LIST

Item	Description
1	Cover with Lock and access door
2	1 HP Brushless DC Motor
3	Gear Reducer for 1 HP Motor
4	Cover Locking Bracket
5	Output Sprocket
6	Roller Sprocket/ Idler Wheels
7	BLACK Limit Switch Sensor
8	GRAY Limit Switch Sensor
9	Matrix 1 Control Bd Assembly
10	MAX MC-200 Motor Controller Assembly
11	MAX Toroid 15 Amp Box
12	Main Chassis
13	MAX BC-7 Battery Module (7 AHr)
14	Single Gang Electrical Boxes

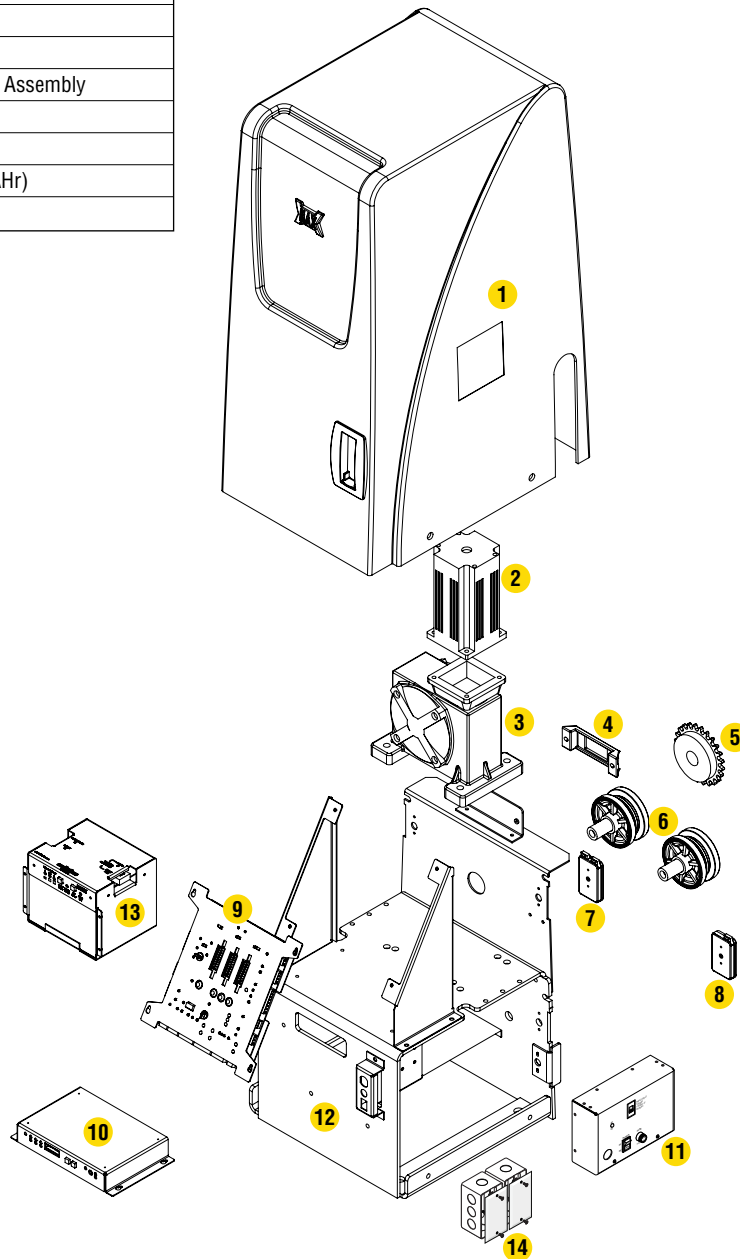

# MAX F18 WARRANTY

Maximum Controls LLC (“Manufacture”) warrants the original purchaser of this product, for the purpose to which this product is originally installed, that the product is free from defect in materials and/or workmanship for a period of 8 years for the Brushless DC Motor and cover, 5 years for everything else with the exception of the batteries which are limited to a 1 year warranty. The performance of this product is dependent on compliance to the instructions, maintenance, operation, and testing clearly outlined in the user manual. Failure to comply completely with those instructions will void this warranty in its entirety. This warranty does not cover damage to the product caused by vandalism, water damage, direct hit lightning strike, or installation errors. This warranty does not include any labor charges that might be needed to troubleshoot, replace, or repair a problem.

If, during the limited warranty period, one of the components exhibits a defect in material and/or workmanship, please call 949-699-0220 before dismantling the product. Shipping instructions and an RMA (Return Material Authorization) Number will be issued by the factory service center when contacted. Do not send any product in for service without an RMA number. Shipping charges to and from the factory service center for warranty repairs are the responsibility of the customer. Repair or replacement of any warranty items is made at the sole discretion of the Manufacturer.

ALL IMPLIED WARRANTIES FOR THE PRODUCT, INCLUDING BUT NOT LIMITED TO ANY WARRANTIES OF MERCHANTABILITY AND SUITABILITY FOR A PARTICULAR PURPOSE, ARE LIMITED TO 8 YEARS FOR THE BRUSHLESS MOTOR DC AND COVER, 5 YEARS FOR EVERYTHING ELSE WITH THE EXCEPTION OF THE BATTERIES WHICH ARE 1 YEAR. NO IMPLIED WARRANTIES WILL EXTEND BEYOND THE WARRANTIES LISTED ABOVE. Some states do not allow limitations on how long an implied warranty last so this limitation might not apply to you.

This Limited warranty does not cover any problems with or relating to, the gate, the gate hardware, including but not limited to hinges, rollers, brackets, entry devices etc. Any service call that determines the cause of a problem to be external to the product could result in a fee. Under no circumstances shall the manufacture be liable for consequential, incidental or special damages arising in connection with the use, or inability to use, this product. Under no circumstances will the Manufacture’s liability for breach of warranty, breach of contract, negligence or strict liability exceed the cost of the product covered other liability in connection with the sale of this product.

## OPTIONS / UNIQUE FEATURES

“Like NO other Gate Operator in the World”

### **GATE TAMPER FEATURE**

The **GATE TAMPER** feature will activate the relay when a number of security circumstances occur, making illegal entry almost impossible when the gate operator is connected to an existing building/home alarm system. The **GATE TAMPER** relay will activate when:

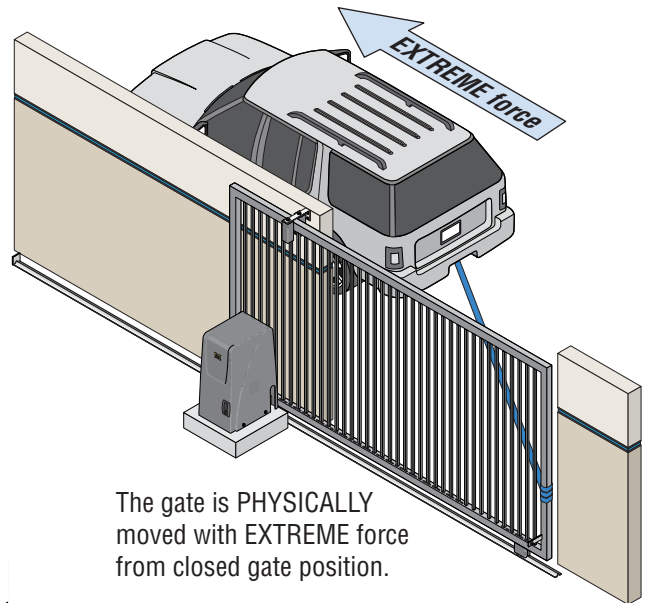
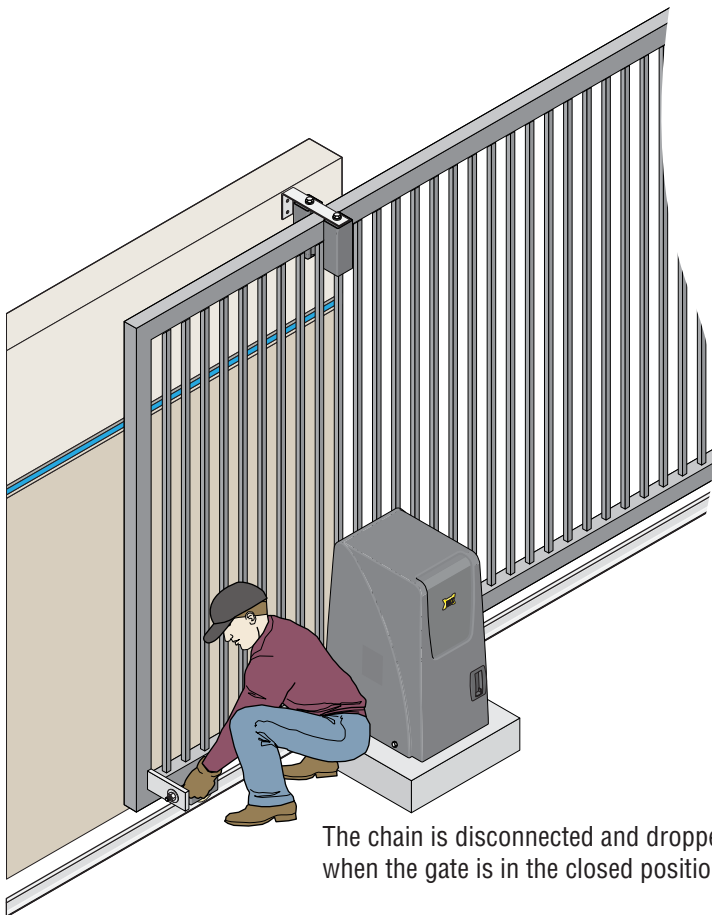



## OPTIONS / UNIQUE FEATURES

“Like **NO** other Gate Operator in the World”

### MAGNETIC DYNAMIC BRAKE SYSTEM

This unique built-in feature controls the gate's open and close stopping positions. When a gate is installed on a slight incline or decline, gate coasting can be a concern. When the motor stops, the momentum of a heavy gate can continue coasting beyond the gate's stopping position. This can be a problem, especially when closing bi-parting gates meet. The MAX F18 **WILL NOT ALLOW** gate coasting beyond its learned stopping position, even when the gate is installed on a slight incline or decline.

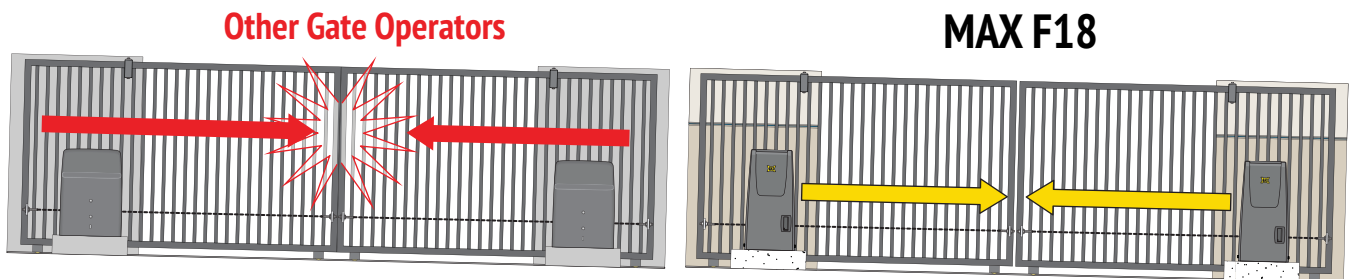

Other gate operators can coast when motor stops, causing gates to hit each other.

MAX F18 **WILL NOT ALLOW** gate coasting. Gates stop at the same position every time.

### GEAR REDUCER

This feature does **NOT** allow the gate to be manually pushed open by multiple people. It takes several thousand pounds of force to physically move the gears on the gear reducer. Even if several people try and push the gate open, the gear reducer ratio will prevent gate movement. If the gate does move, the **GATE TAMPER** feature will activate and the proper authorities can be automatically notified if desired.



The gate **WILL NOT** move using human force.

## OPTIONS / UNIQUE FEATURES

**“Like NO other Gate Operator in the World”**

### **PARTIAL OPEN FEATURE**

This feature controls a long gate's normal open and close stopping positions compared to **emergency situations** that require the gate to **ALWAYS FULLY OPEN**. It is important to have FULL ACCESS in time of emergency but this occurs much less than the normal daily operations. MAX operators will EASILY operate in either circumstance. **A long gate** may not need to fully open to allow normal access, especially in high traffic areas where gate cycling time can be reduced between vehicles and still allow normal daily operations to occur. Time between vehicles can be greatly reduced, not to mention all of the benefits that occur when using **PARTIAL OPEN**.

- Less wear and tear on the gate operator.
- Less maintenance and repairs.
- Less power consumption.
- Less time between gate cycles.
- Better access control of the area.
- Better security of the area.

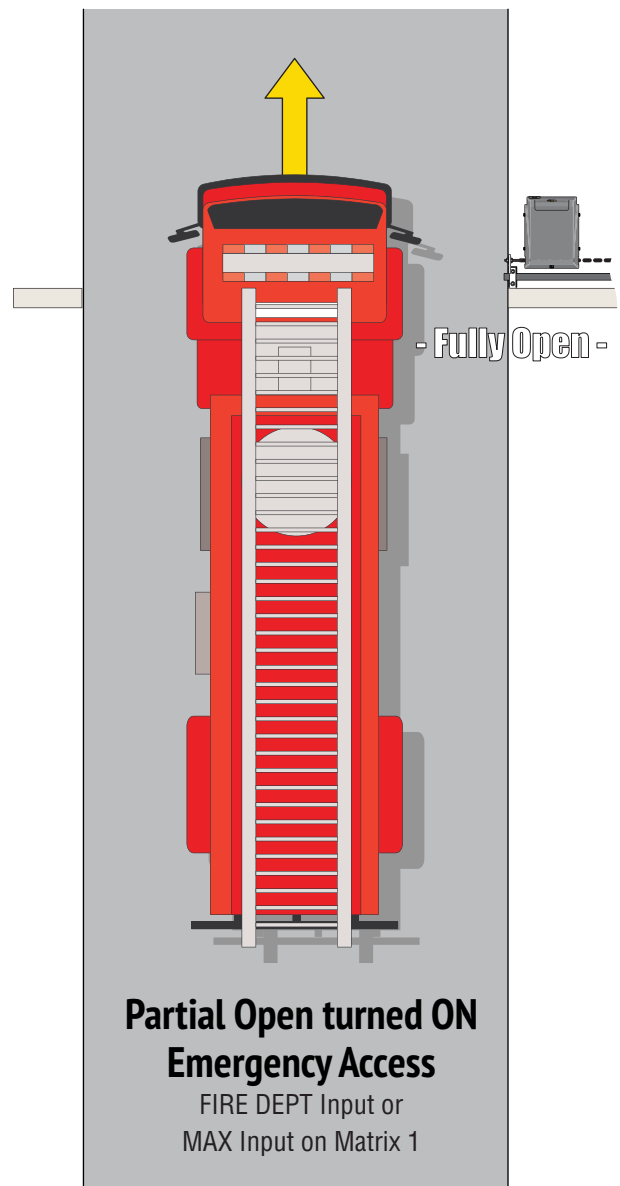
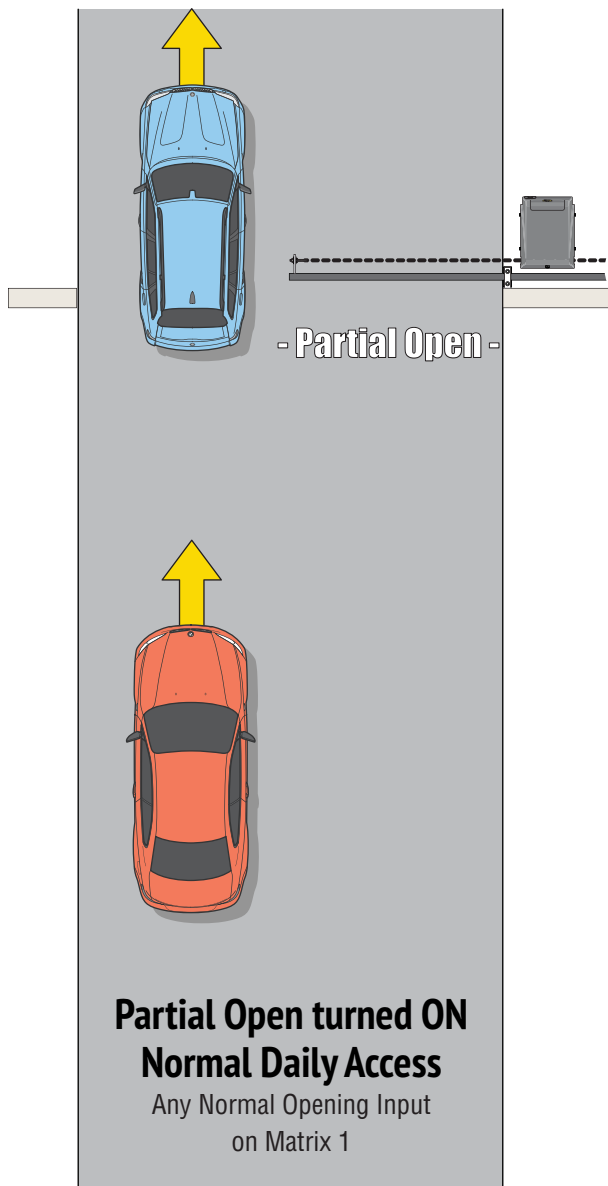

# OPTIONS / UNIQUE FEATURES

“Like NO other Gate Operator in the World”

## GATE DISABLE FEATURE

This unique **GATE DISABLE** feature is useful when the gated area needs to be secured from **ALL** but emergency and/or authorized vehicle entry. Some examples are:

- Residential home vacation period.
- During closed hours of a business.

The **GATE DISABLE** feature will allow the FIRE DEPT/MAX and RADIO inputs to operate but nothing else. It helps with some major security problems that can occur when no one is available to monitor the property.

**GATE DISABLE** prevents breaking into a keypad box and trying to trigger the wires to get the gate to open.

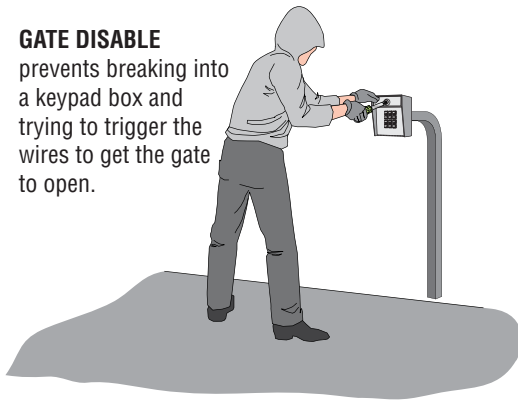

**GATE DISABLE** prevents trying to trigger the exit loop to get the gate to open.

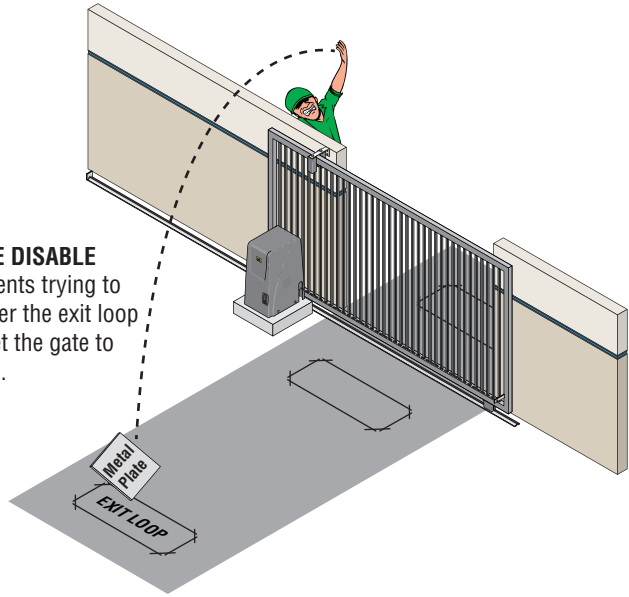

**IMPORTANT:** It is **NOT** recommended activating **GATE DISABLE** while persons are present inside the property.

## EVENT HISTORY DOWNLOAD

This unique **EVENT HISTORY** feature has an On Board Diagnostics (OBD) port to download a simple .txt file to troubleshoot gate operator errors and to view normal transaction logs. This file will log intermittent problems with the gate operator that can be difficult to solve. This file can even be e-mailed to the factory from out in the field at the job site for additional technical support if necessary.

The event history can store up to 1000 transactions.

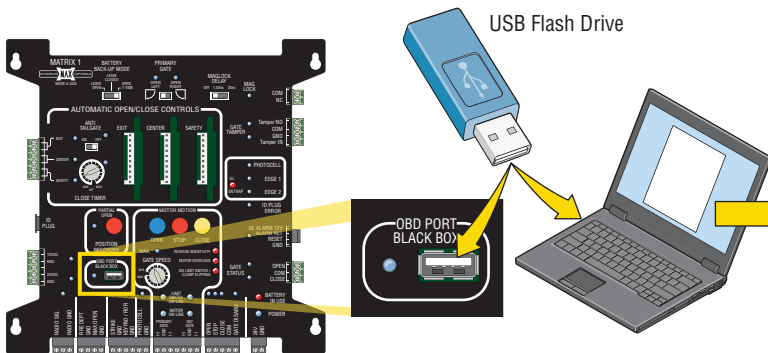

## Event History Text Document Sample

Event type clarification:

**INFO:** informational message only

**WARNING:** unusual event but doesn't cause system malfunction

**ERROR:** abnormal event, could cause system malfunction

**ENTRAP:** entrapment detection event

Event Report:

Fri 07/11/2014 10:59:41	INFO : Cycle Counter
Fri 07/11/2014 10:59:41	<b>ENTRAP : SEC_MC: First ERD Detected</b>
Fri 07/11/2014 10:59:37	INFO : Radio Input Deactivated
Fri 07/11/2014 10:59:36	INFO : Radio Input Activated
Fri 07/11/2014 10:58:54	INFO : PRI_MC: Fully Open Position Learned
Fri 07/11/2014 10:58:53	INFO : SEC_MC: Fully Open Position Learned
Fri 07/11/2014 10:57:40	INFO : PRI_CIO: Communication Established
Fri 07/11/2014 10:57:38	<b>ENTRAP : PRI_MC: Photo Cell Deactivated</b>
Fri 07/11/2014 10:57:34	<b>ENTRAP : PRI_MC: Photo Cell Activated</b>
Fri 07/11/2014 10:57:21	INFO : Radio Input Deactivated
Fri 07/11/2014 10:57:21	INFO : Radio Input Activated
Fri 07/11/2014 10:56:46	<b>WARNING: PRI_MC: Tamper Reported</b>
Fri 07/11/2014 10:56:36	INFO : SEC_MC: Fully Open Position Unknown
Fri 07/11/2014 10:56:36	INFO : PRI_MC: Fully Open Position Unknown
Fri 07/11/2014 10:56:36	<b>WARNING: PRI_MC: Tamper Reported</b>
Fri 07/11/2014 10:56:33	ENTRAP : PRI_MC: Photo Cell Deactivated
Fri 07/11/2014 10:56:33	ENTRAP : PRI_MC: Photo Cell Activated
Fri 07/11/2014 10:56:33	ENTRAP : PRI_MC: Photo Cell Deactivated
Fri 07/11/2014 10:56:33	ENTRAP : PRI_MC: Photo Cell Activated

## OPTIONS / UNIQUE FEATURES

**“Like NO other Gate Operator in the World”**

### **MAX CHAIN RELEASE MECHANISM - OPTIONAL**

Maximum Controls offers a **MAX chain release** mechanism that can provide an easy **MANUAL** gate release for slide gate operators. It can be installed on any sliding gate that uses a chain drive. This allows a user to quickly drop the chain without any tools to **MANUALLY** move the sliding gate to an open position.

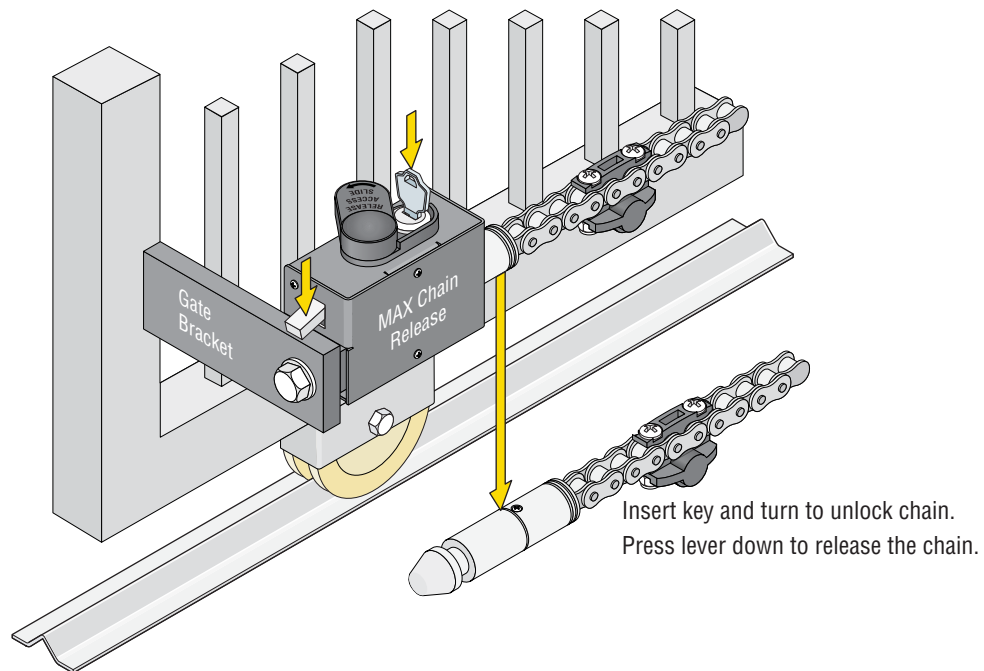
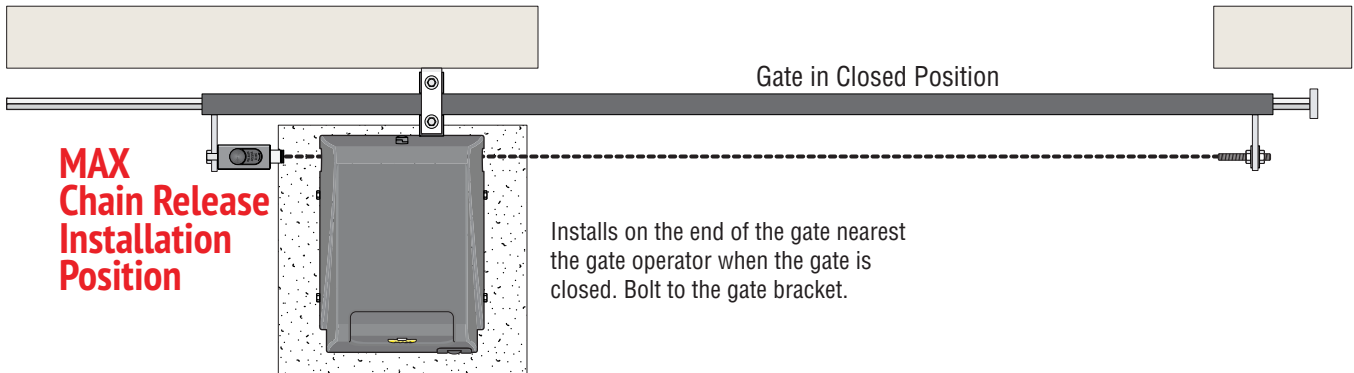



[www.max.us.com](http://www.max.us.com)

CONFORMS TO UL STD 325  
UL CLASS - III, IV

CERTIFIED TO CAN/GSA STD  
C22.2 NO. 247



**Commercial/Industrial  
UL 325 Class III & IV ONLY  
FAST SLIDE - Up to 18 in/sec  
Brushless DC Slide Gate Operator**

NOT intended for residential use

Made in USA



Intertek  
4009963

Maximum Controls LLC.  
27211 Burbank  
Foothill Ranch, Ca 92610  
Tel: (949) 699-0220