

LockMaster™

Swing Gate Operator User's Manual

Model:

LM 901/902

CE EMC FC

Table of Contents

Safety Installation Information	2-3
Dual Gate Opener Parts List (902)	4
Single Gate Opener Parts List (901)	5
Optional Accessories Parts List.....	6
Technical Specifications & Features	7
Installation Overview	8-9
Preparation for Installation.....	9-10
Determining the Position of Mounting Hardware.....	10-12
Installing the Mounting Hardware.....	12-13
Installation of the Opener.....	13
Mounting the Control Box	14-15
Connecting Opener Power Cables	16-17
Wiring Diagram.....	17
Control Board Settings	17-20
Indicate Illustration on Digital Display When Gate Opener Is Running	21
Adjust the Limit Switch	21-22
How to Operate	22
Emergency Release	22
Accessories Connection	23-24
Installation for Push-to-Open Gates.....	24-25
Maintenance.....	26
Trouble Shooting.....	26-27
Quick-Setting Guide.....	27-30

Safety Installation Information

1. READ and FOLLOW all instruction.

2. The gate opener is intended for use with Class I vehicular swing gates.

Class I denotes a vehicular gate opener (or system) dwellings, or a garage or parking area associated therewith.

Install the gate opener only when the opener is appropriate for the construction and the usage class of the gate.

3. Gate opening system designers, installers and users must take into account the possible hazards associated with each individual application. Improperly designed, installed or maintained systems can create risks for the user as well as the bystander. Gate system design and installation must reduce public exposure to potential hazards. All exposed pinch points must be eliminated or guarded.

4. A gate opener can create high levels of force during normal operation. Therefore, safety features must be incorporated into every installation. Specific safety features include safety sensors.

5. The gate must be properly installed and work freely in both directions prior to the installation of the gate opener.

6. The gate must be installed in a location so that enough clearance is provided between the gate and adjacent structure when opening and closing to reduce the risk of entrapment. Swinging gates shall not open into public access areas.

7. The opener is intended for use only on gates used for vehicles. Pedestrians must be supplied with a separate access opening. The pedestrian access opening shall be designed to promote pedestrian usage. The pedestrian access shall be located such that persons will not come in contact with the moving vehicular gate.

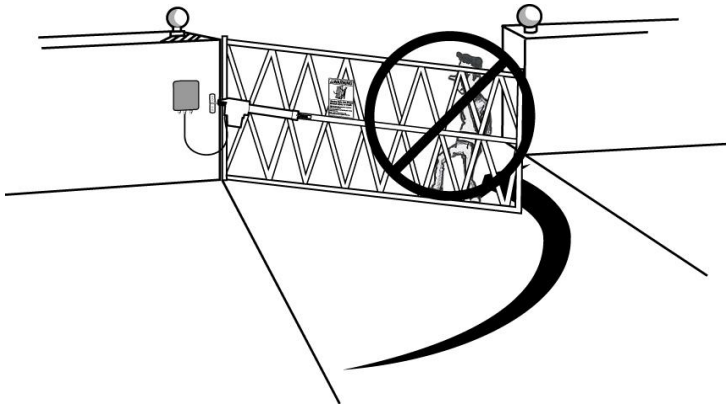

8. Pedestrians should never cross the pathway of a moving gate. The gate opener is not acceptable for use on any pedestrian gate. Pedestrians must be supplied with a separate pedestrian access.

9. For an installation utilizing non-contact sensors (safety sensors), see product manual on the placement of non-contact sensors (safety sensors) for each type of application.

a. Care shall be exercised to reduce the risk of nuisance tripping, such as when a vehicle trips the safety sensor while the gate is still moving.

b. One or more non-contact sensors (safety sensors) shall be located where the risk of entrapment of obstruction exists, such as the perimeter reachable by a moving gate or barrier.

10. Never mount any device that operates the gate opener where the user can reach over, under, around or through the gate to operate the controls. Controls are to be placed at least 6' (1.8m) from any part of the moving gate.

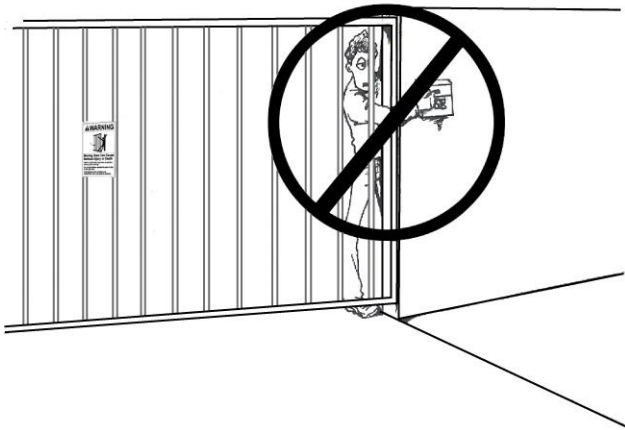

11. Controls intended to be used to reset an operator after 2 sequential activations of the entrapment protection device or devices must be located in the line of sight of the gate, or easily accessible controls shall have a security feature to prevent unauthorized use. Never allow anyone to hang on or ride the gate during the entire travel of the gate.
12. Each gate opener is provided with two safety warning placards. The placards are to be installed on the front and back of the gate where they are plainly visible. The placards may be mounted using cable ties through the four holes provided on each placard.

All warning signs and placards must be installed where visible in the area of the gate.

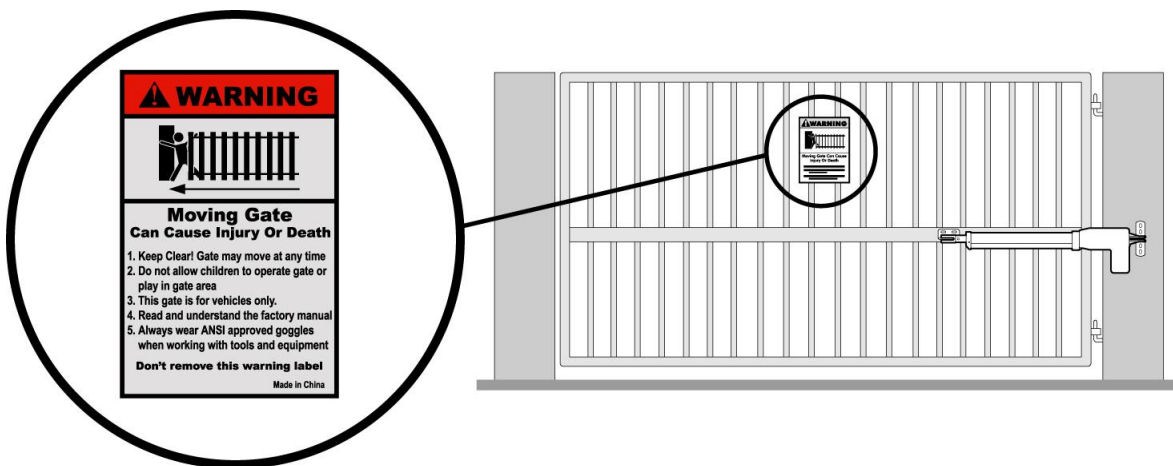









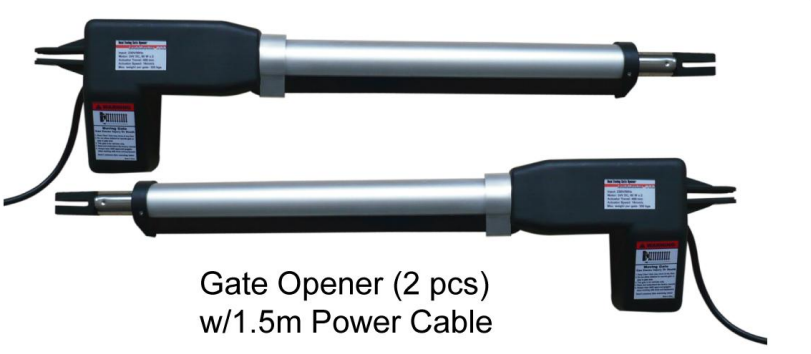
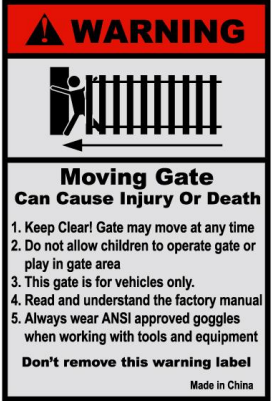











13. To AVOID damaging gas, power, or other underground utility lines, contact underground utility locating companies BEFORE digging.
SAVE INSTRUCTION.

 WARNING
<p>To prevent SERIOUS INJURY or DEATH from a moving gate:</p> <ul style="list-style-type: none"> • Install warning signs on the front and back of the gate in PLAIN VIEW. • Permanently secure each warning sign in a suitable manner using fastening holes.





















Dual Gate Opener Parts List (902)

Opener and Mounting Hardware

 <p>Gate Opener (2 pcs) w/1.5m Power Cable</p>		 <p>Warning Signs (4 pcs)</p>
 <p>Control Box (1 pc)</p>	 <p>Triangular Key (2 pcs)</p>	
	 <p>FCC Remote Control (2 pcs)</p>	 <p>CE Remote Control (2 pcs)</p>
<p>Either CE or FCC Remotes are provided depending on consumer area.</p>		
 <p>Post Pivot Bracket (2 pcs)</p>	 <p>Gate Bracket (2 pcs)</p>	 <p>Post Bracket (4 pcs)</p>
<h3>Hardware</h3>		
 <p>Φ10 Washer (14 pcs)</p>	 <p>M10×200 Bolt (8 pcs)</p>	
 <p>Φ10 Lock Washer (14 pcs)</p>	 <p>M10×75 Bolt (4 pcs)</p>	
 <p>Φ8 Washer (2 pcs)</p>	 <p>M10×30 Bolt (2 pcs)</p>	
 <p>M10 Nut (14 pcs)</p>	 <p>M8×30 Bolt (2 pcs)</p>	
 <p>M8 Nut (2 pcs)</p>	 <p>12×40 Clevis Pin (2 pcs)</p>	
 <p>Hairpin Clip (4 pcs)</p>	 <p>12×30 Clevis Pin (2 pcs)</p>	

Single Gate Opener Parts List (901)

Opener and Mounting Hardware

 <p>Gate Opener (1 pc) w/1.5m Power Cable</p>		 <p>WARNING</p> <p>Moving Gate Can Cause Injury Or Death</p> <ol style="list-style-type: none"> 1. Keep Clear! Gate may move at any time 2. Do not allow children to operate gate or play in gate area 3. This gate is for vehicles only. 4. Read and understand the factory manual 5. Always wear ANSI approved goggles when working with tools and equipment <p>Don't remove this warning label</p> <p>Made in China</p>
 <p>Control Box (1 pc)</p>	 <p>Triangular Key (1 pcs)</p>	
	 <p>FCC Remote Control (2 pcs)</p>	 <p>CE Remote Control (2 pcs)</p>
<p>Either CE or FCC Remotes are provided depending on consumer area.</p>		
 <p>Post Pivot Bracket (1 pc)</p>	 <p>Gate Bracket (1 pc)</p>	 <p>Post Bracket (2 pcs)</p>
<h3>Hardware</h3>		
 <p>Φ10 Washer (7 pcs)</p>	 <p>M10×200 Bolt (4 pcs)</p>	
 <p>Φ10 Lock Washer (7 pcs)</p>	 <p>M10×75 Bolt (2 pcs)</p>	
 <p>Φ8 Washer (1 pc)</p>	 <p>M10×30 Bolt (1 pc)</p>	
 <p>M10 Nut (7 pcs)</p>	 <p>M8×30 Bolt (1 pc)</p>	
 <p>M8 Nut (1 pc)</p>	 <p>12×40 Clevis Pin (1 pc)</p>	
 <p>Hairpin Clip (2 pcs)</p>	 <p>12×30 Clevis Pin (1 pc)</p>	

Optional Accessories Parts List

Optional			
 Back up battery (1 set) (LM125)	 Wall push button (1 pc) (LM145)	 Keypad (wireless) (1 pc) (LM105)	 Mounting post for keypad (1 pc) (LM107)
 Back up battery box (1 pc) (LM130)	 Alarm Lamp (1 pc) (LM140)	 Photocell Beam System (1 set) (LM102)	
 Battery emergency charger (1 pc) (LM135)	 Solar panel (1 pc) (LM109)	 Supporting frame for solar panel (1 pc) (LM115)	 Bracket for solar panel (1 pc) (LM116)
 5-core wire (LM150 Wire A)	 2 x 0.3 sq.mm (LM151 Wire B)	 2 x 0.75 sq.mm (LM152 Wire C)	

Tools Needed:

- Power Drill
- Tape Measure
- Open End Wrenches — 14# & 17# or Adjustable Wrenches
- Wire Strippers
- C-Clamps — small, medium, and large
- Level
- Hacksaw or Heavy Duty Bolt Cutters
- Phillips Screwdriver
- An extra person will be helpful

Technical Specifications & Features

Specifications:

- Input: 230V/50Hz or 120V/60Hz
- Motor voltage: 24VDC
- Power: 80W each actuator
- Current: 3A
- Actuator arm speed: 16mm/s
- Max. Actuator arm travel: 385mm
- Max. Weight of the gate: 300kg
- Max. Width of the gate: 3m
- Ambient Temperature: -20°C ~ +50°C (-4°F to 122°F)
- Protection class: IP44

Features:

- Soft start
- Emergency release key in case of power failure
- Dual/Single gate running mode
- Adjustable opening/closing interval between master and slave gate
- Stop/Reverse in case of obstruction during gate opening/closing.
- Built in adjustable auto-close (0-9 minutes)
- Built in TIMER-TO-CLOSE adjustable for multiple safety protection (0-60 seconds)
- Digital display indicates the running situation and setting menu
- Reliable electromagnetism limit for easy adjustment
- Optional alarm lamp and photocell protection
- Optional push button
- Optional back up battery & solar panel charging kit
- Optional keypad

Installation Overview

Single Gate Overview Pull-to-Open Gate

⚠ WARNING To prevent SERIOUS INJURY or DEATH, at least one non-contact sensor should be located where the risk of entrapment or obstruction exists.

Left-Hand Gate

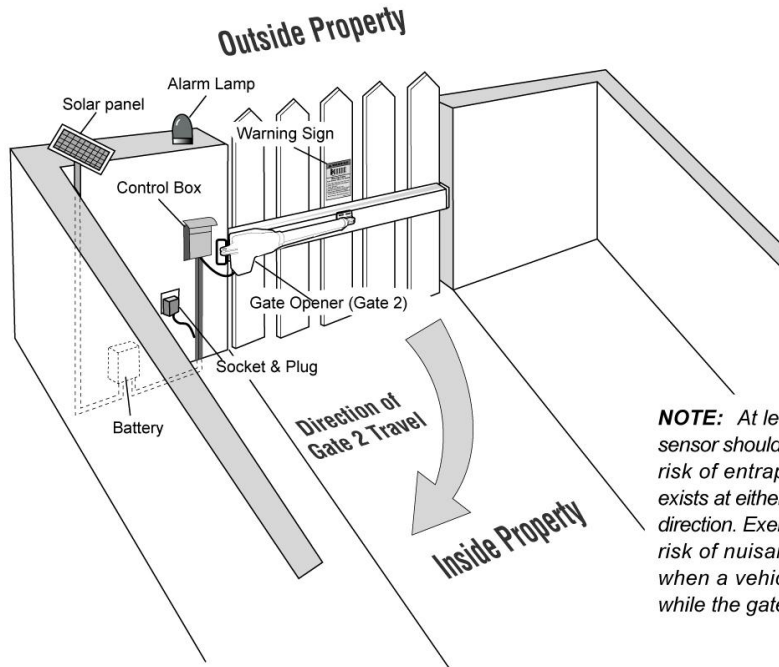

NOTE: At least one non-contact sensor should be located where the risk of entrapment or obstruction exists at either the opening or closing direction. Exercise care to reduce the risk of nuisance tripping, such as, when a vehicle trips the sensor while the gate is still moving.

Right-Hand Gate

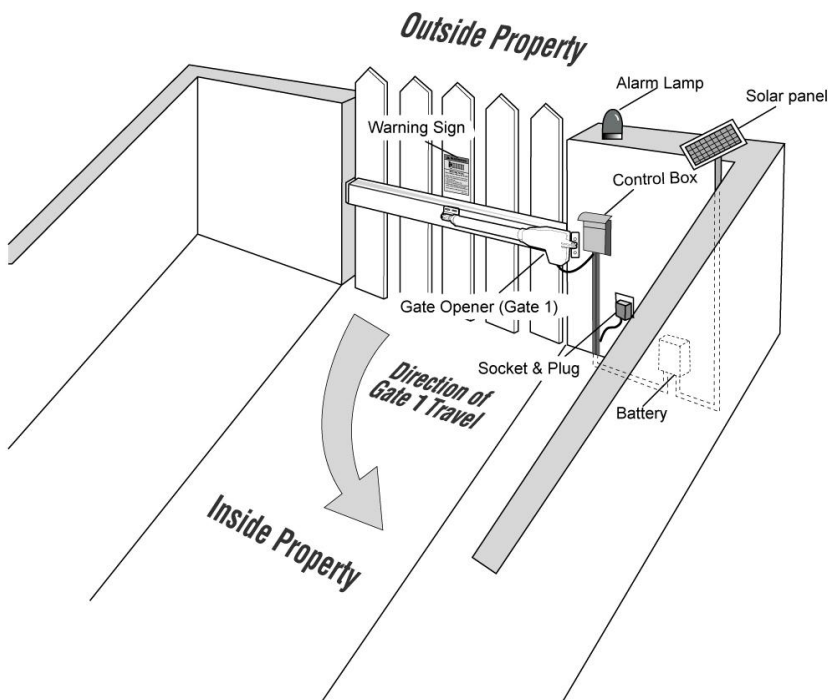

Dual Gate Overview Pull-to-Open Gates

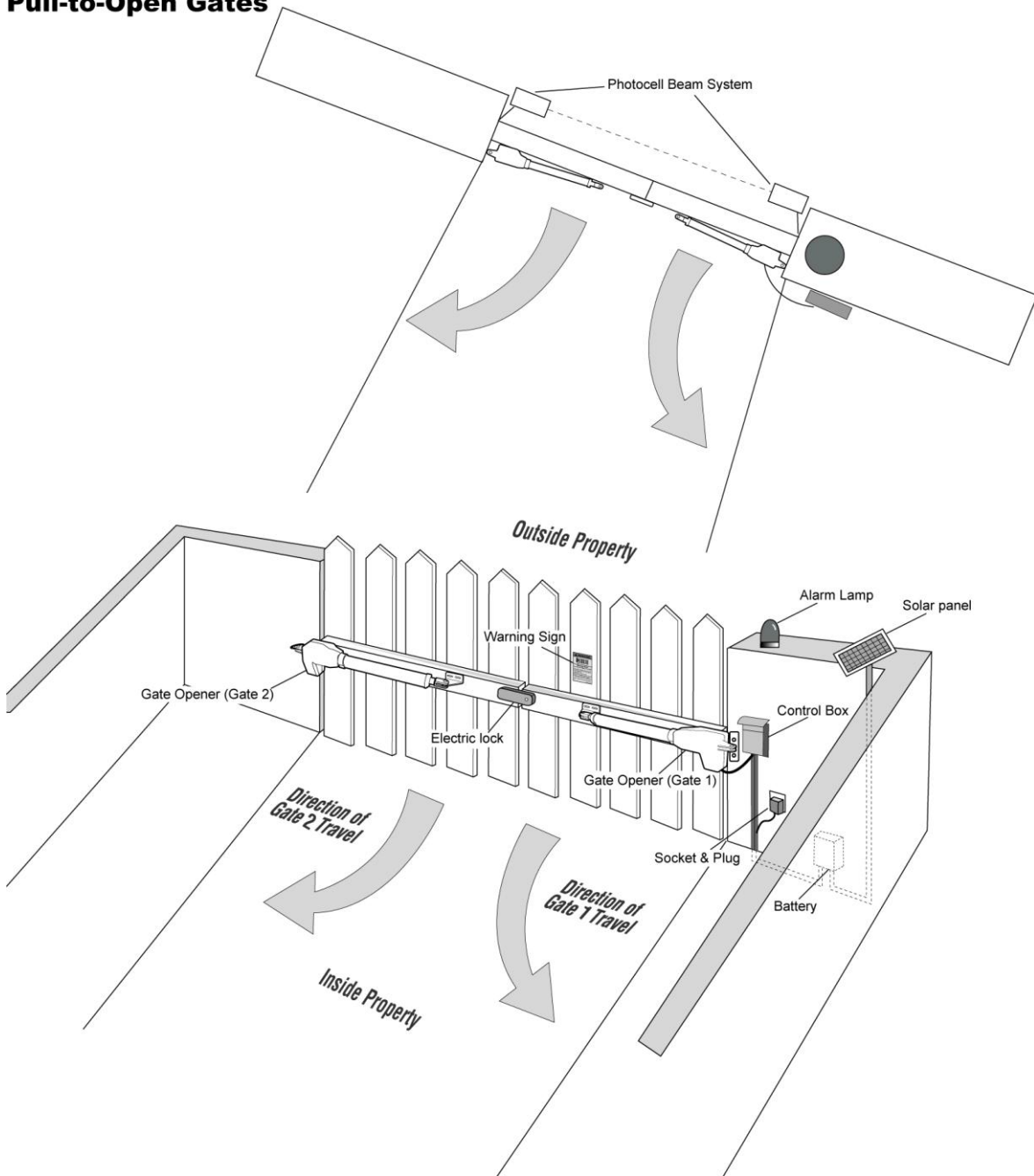

Important:

The second gate opener cable should be put into the PVC conduit (not provided) what is buried underground. This protects the cable from lawn mowers and string trimmers.

Preparation for Installation

The proper position of the post brackets is a decisive factor to the efficiency and leverage of the gate opener. The distance (usually it is 2.5cm / 1 inch or more) between the gate opener and the gate is also determined by the proper position of the post brackets.

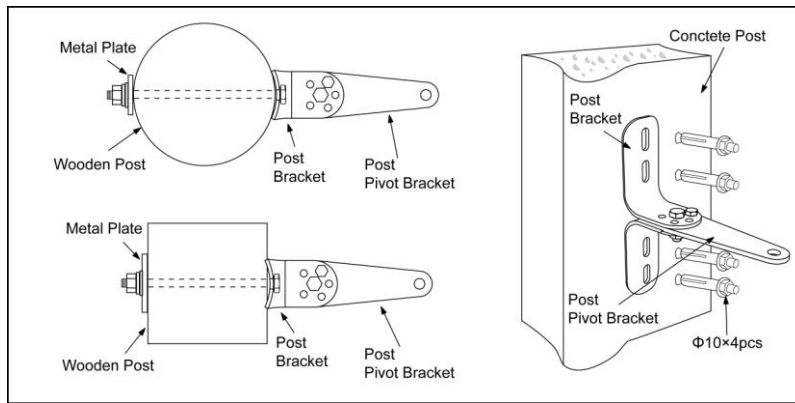

Both round and square post can be used because of the curved design of the post brackets. When mounting the post brackets, use bolts long enough to pass through the entire post. When mounting the post brackets to wooden posts, a larger-size washer or metal plate should be used between the bolts and the wood post to ensure the stability of the fastening hardware when thrust is used.

If the gate post is smaller than 15 cm (6") diameter or square, they should be made of metal and set in cement to ensure the stability of the post.

Determining the Position of Mounting Hardware

NOTE: The following steps are intended for **Pull-to-Open** gate installation only. You will find a series of sizes from following chart to determine the proper mounting position

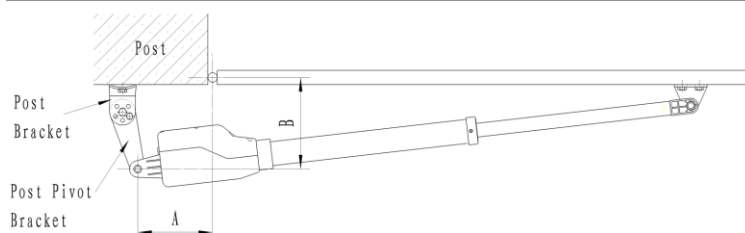

Note: A+B can not exceed 38cm
For Example: If A is 20cm then B can not exceed 18cm

	A=12cm	A=13cm	A=14cm	A=15cm	A=16cm	A=17cm	A=18cm	A=19cm
B=19cm	93°	96°	98°	100°	103°	98°	95°	92°
B=20cm	92°	95°	98°	100°	98°	95°	92°	89°
B=21cm	93°	95°	97°	98°	94°	91°	89°	87°
B=22cm	93°	95°	98°	93°	90°	88°	86°	84°
B=23cm	93°	96°	93°	90°	87°	85°	83°	82°
B=24cm	94°	92°	90°	86°	84°	82°	81°	80°

Step 1

Place the post pivot bracket between the two post brackets. Insert the M10x30 bolt through the center hole of the post bracket and post pivot bracket as shown. Place a $\Phi 10$ washer, $\Phi 10$ lock washer and M10 nut on the bottom of the bolt and hand tighten.

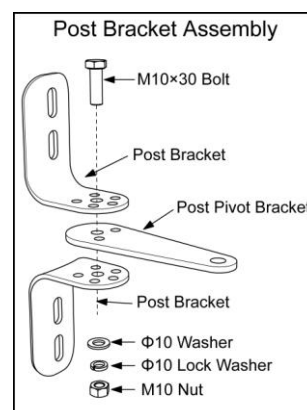

Step 2

Attach the gate bracket and post bracket assembly to the opener by inserting a clevis pin. Secure the clevis pins using the hairpin clips.

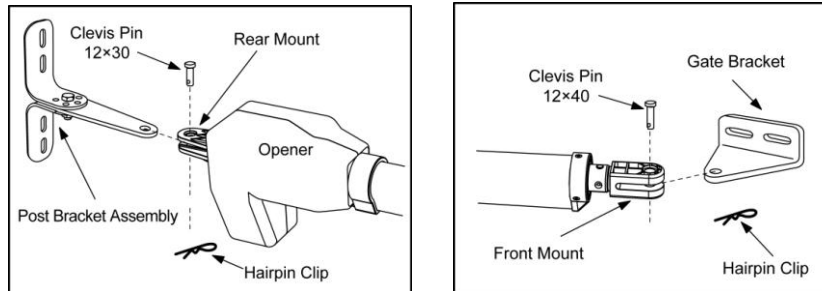

Step 3

With the gate in their desired open positions (from 0° to 100° from the gate's closed position) and with the opener in their retracted positions, place the opener with the gate bracket and post bracket assembly on the gate post and the gate. Position the gate bracket and the post bracket assembly so that the gate opener is level with the horizontal cross member of the gate. While holding the opener in the desired level position, temporarily secure it with two C-clamps.

NOTE: There is an emergency release design. Use the triangular key to unlock the opener, you can stretch the moving rod or retract it by using hand to pull or push the front mount assembly. **Be sure that the openers are both locked before you prepare to activate your openers.** Other information please refer to content in page 22.

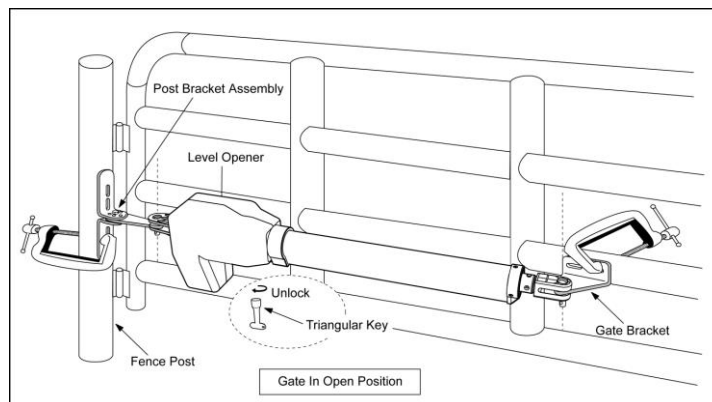

Step 4

Determine the optimum position of the pivot bracket on the post bracket assembly by ensuring a minimum 2.5cm (1 inch) distance exists between the gate and the gate opener in both the gate-open and gate-closed positions. To ensure the minimum 2.5cm (1 inch) distance maintained in the gate-closed position, remove the clevis pin from the gate bracket while holding the gate opener, then close the gate. Move the gate opener so as the gate bracket and the opener are aligned.

NOTE: Ensure the gate opener and the pivot brackets do not bind in the gate –open and gate –closed positions.

If you don't have enough distance, or the gate opener is binding on the post pivot bracket, you may move the post pivot bracket assembly slightly to the right or left to obtain the proper distance.

After you've identified the desired position of the pivot bracket, place the M8 x 30 bolt into the desired pivot on the post bracket.

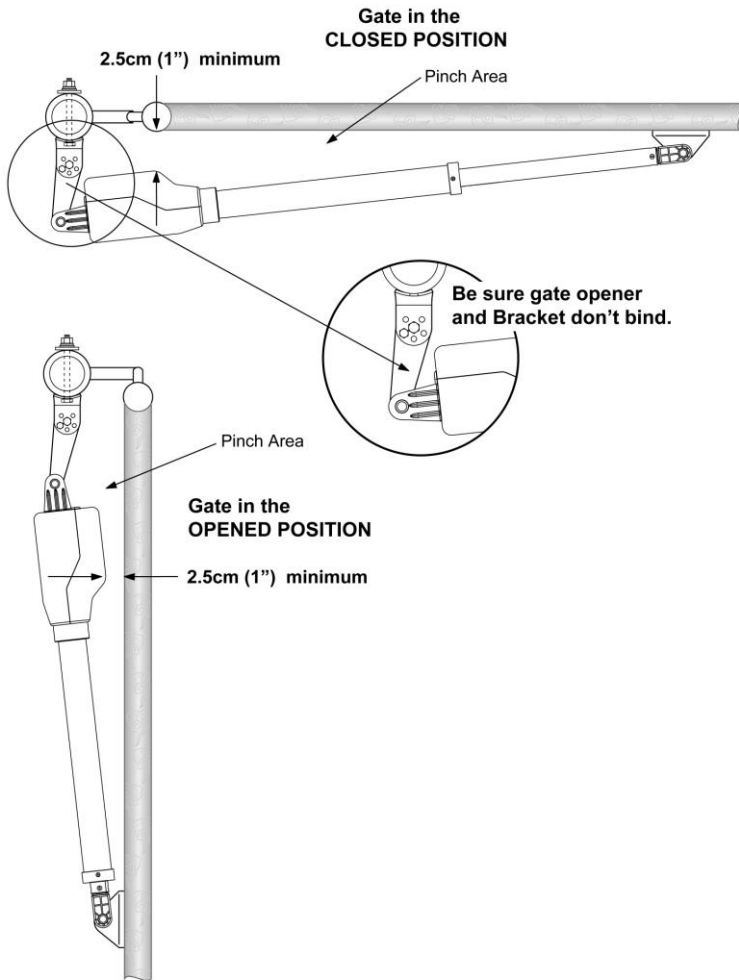

Installing the Mounting Hardware

Step 5

Sign the bolt-hole point on the gate bracket and gate. Do this by placing a punch or a sign in the middle of each bolt slot on the post bracket assemblies and the gate bracket. It allows slight adjustments to the post bracket. Then remove the post bracket and gate bracket by taking off the C-clamps.

Step 6

Using a drill and a bit of $\varnothing 10.5$, drill holes through the post and the gate at the sign bolt hole point.

Step 7

Attach the post bracket assemblies to the gate posts by inserting four M10 x 200 bolts through each post bracket assembly and the drilled holes in the gate post. Fasten each bolt with one $\varnothing 10$ washer, one $\varnothing 10$ lock washer, and one $\varnothing 10$ nut.

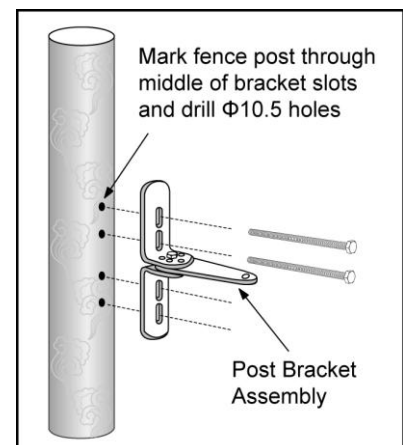

Step 8

Attach the gate brackets to each gate by inserting two M10 x 75 bolts through the gate brackets and the drilled holes in the gates. Fasten each bolt with one \varnothing 10 lock washer, and one \varnothing 10 nut.

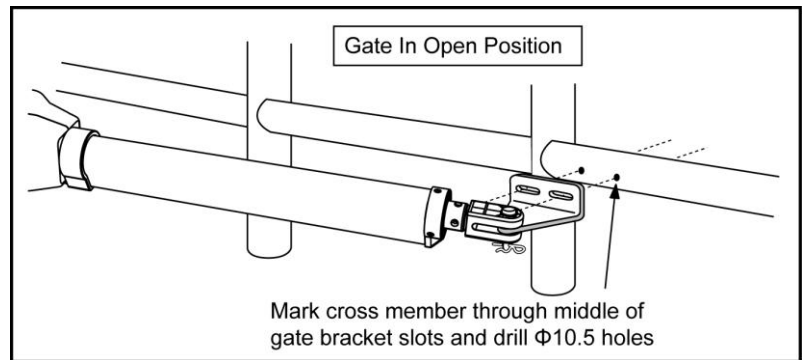

Step 9

Cut all parts of bolt which is extending beyond the tightened nuts by saw.

Installation of the Opener

Step 10

Attach the gate opener to the securely fastened post bracket assemblies and gate brackets by using the four clevis pins. Insert one clevis pin through the gate opener and the gate bracket. Insert the other clevis pin through the gate opener and the post bracket assembly. Secure the clevis pins with the two hairpin clips.

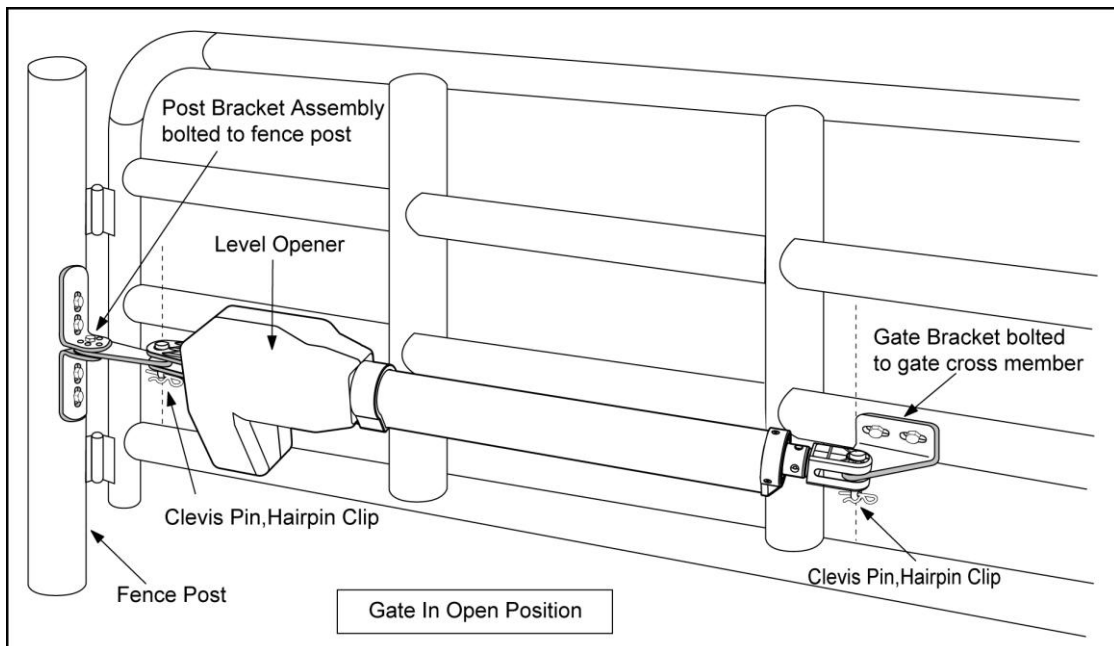

Mounting the Control Box

Step 1

To install the control box use the deck screws (not provided). Ensure the control box is installed in a secure surface and at least 100 cm (40 inches) above the ground to protect it from rain, snow, etc. which probably cause damage to the control box.

Warning: Before connecting the AC power cable to the control box, check the plug of power cable is disconnected from AC power socket.

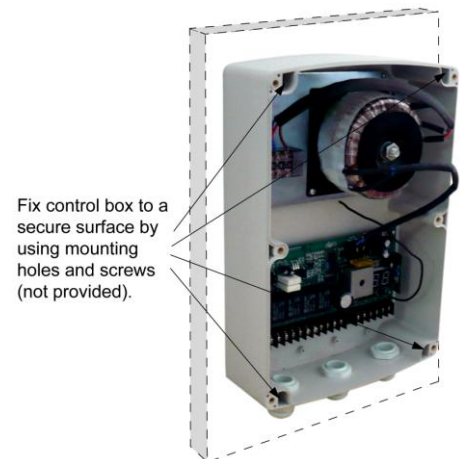

Step 2

Insert the power cable and cable of the first gate opener through the front strain relief and into the control box by loosening the strain relief screw located the leftmost of outside bottom of the control box and feeding the cables into the control box. Check the length of cable is longer enough to their respective terminal block in control box. Retighten the sealing nut so that cables are well locked.

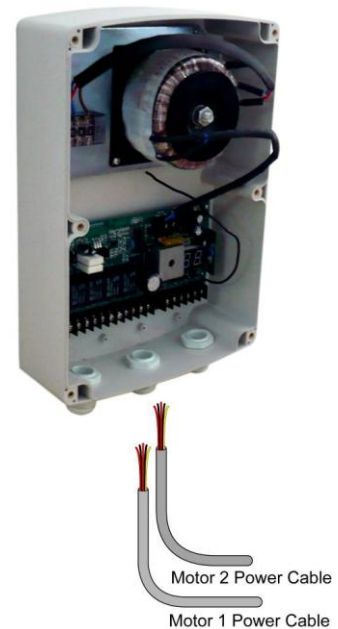

Strain Relief	
	Lock Nut
	Hub
	Sealing Nut

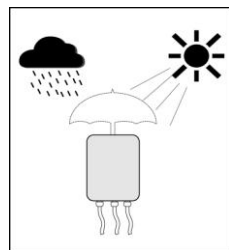

CAUTION: Install the Control Box in a well ventilated place protected against rain and sunlight.

NOTE: It is strongly suggested that the control box should be mounted in the side of opener 1 (in the right-hand side from a view inside the gate) so that the electric lock (optional accessory) can be properly installed (See P9).

Step 3

Insert second gate opener cable and alarm lamp cables into the control box through middle strain relief house. Then repeat step 2.

Step 4

Insert other cables into the control box through rightmost strain relief housing. Then repeat step 2.

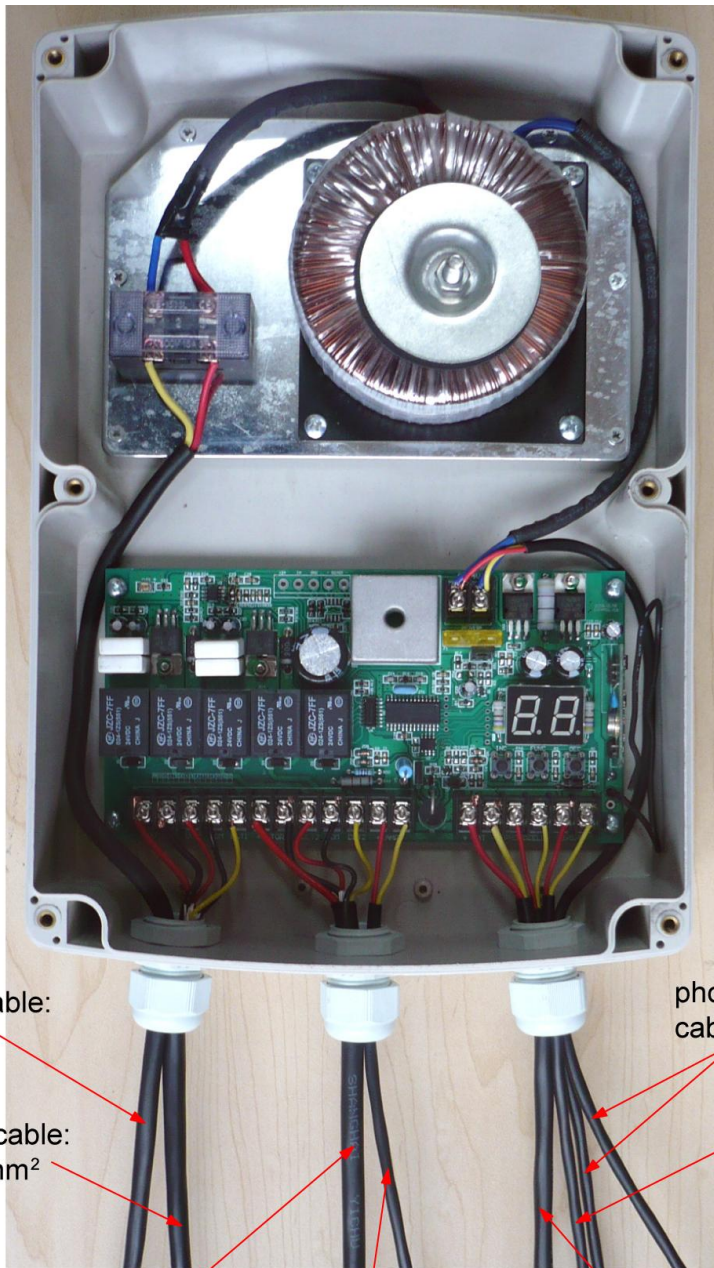

2-core power cable:
2*0.75mm²

motor 1, 5-core cable:
2*1mm² + 3*0.3mm²

motor 2, 5-core cable:
2*1mm² + 3*0.3mm²

alarm lamp 2-core
cable: 2*0.3mm²

photocell two 2-core
cables: 2*0.3mm² × 2

push button 2-core
cable: 2*0.3mm²

battery 2-core
cable: 2*0.75mm²

The cables listed from left to right are as follows:

2-core power cable; motor 1, 5-core cable; motor 2, 5-core cable; alarm lamp 2-core cable; battery 2-core cable; push button 2-core cable; photocell two 2-core cables

NOTE: Only motor cables are provided. Other cables are subject to site installation requirement.

CAUTION: Make sure the cable outlet hole in the Control Box is always down during so as to drain off the water.

Connecting Opener Power Cables

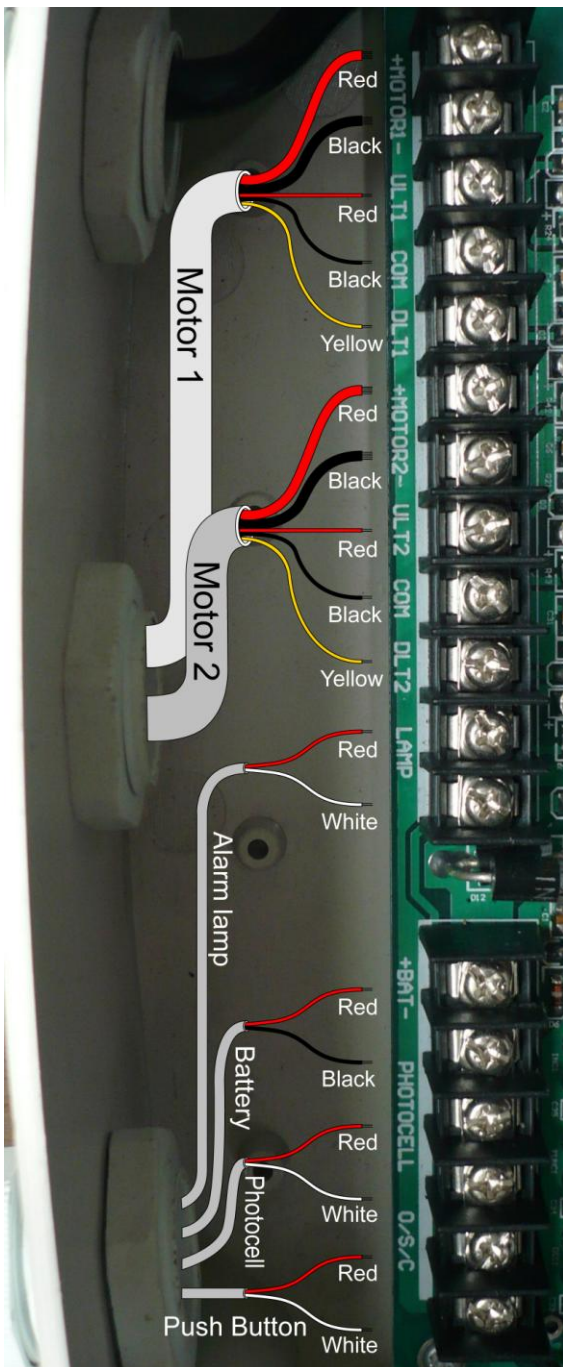

Gate Opener 1

Step 1

Insert the stripped cable wires into the appropriate terminals on the opener terminals block. The red thick wire should be inserted into the **MOTOR1+** terminal, the black thick wire into **MOTOR1-**, the red wire into **ULT1**, the black wire into **COM**, and the yellow wire into **DLT1** terminal.

Gate Opener 2

Step 2

Similar as the step 1, insert the stripped cable wires into the appropriate terminals on the opener terminals block. The red thick wire should be inserted into the **MOTOR2+** terminal, the black thick wire into **MOTOR2-**, the red wire into **ULT2**, the black wire into **COM**, and the yellow wire into **DLT2** terminal.

NOTE: It is recommended that Gate Opener 1 is installed in the Master Gate, and Gate Opener 2 is installed in the Slave Gate.

Alarm Lamp (optional)

Step 3

The red wire should be inserted into either **LAMP** terminal, the white wire into the other one.

Back-up Battery (optional)

Step 4

The red wire should be inserted into the **BAT+** terminal, the black wire into **BAT-**.

Photocell Beam System (PBS) (optional)

Step 5

Please refer to the separate Manual Instruction of PBS Switch

Push Button (optional)

Step 6

The red wire should be inserted into either **O/S/C** terminal, the white wire into the other one.

Wiring Diagram

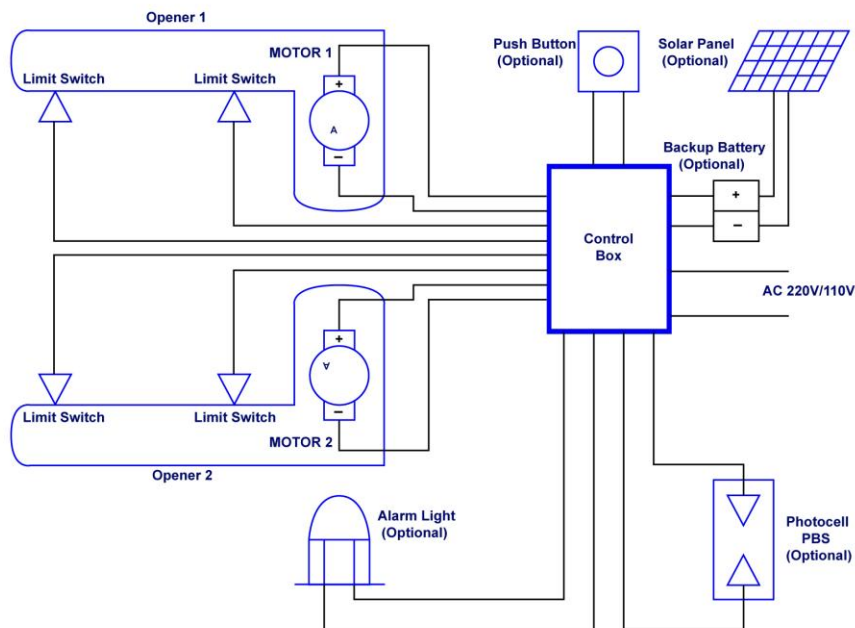

Control Board Settings

1. Check again for completed and correct assembly of your swing gate opener and gate. Plug the Power Grounded Cord into the nearest AC outlet. The Digital Display on the Control Board will flash with “- -”. The unit is in standby.

2. Single/Dual Gate Set

Press and hold the “FUNC” Button for more than 4 seconds. The Digital Display will indicate “P1”. Gate opener is on the SINGLE/DUAL Gate setting. Press the “INC” and “DEC” Buttons respectively to following modes:

“01” shown in Digital Display, it is Single Arm 1 (right-hand side) mode. “10” shown in Digital Display, it is Single Arm 2 (left-hand side) mode. “11” shown in Digital Display, it is Dual arm mode.

Press the “FUNC” button to store the data when the single or dual gate is chosen. The Digital Display will indicate “P2”. Now single/dual gate set is finished.

(Factory set is “11”)

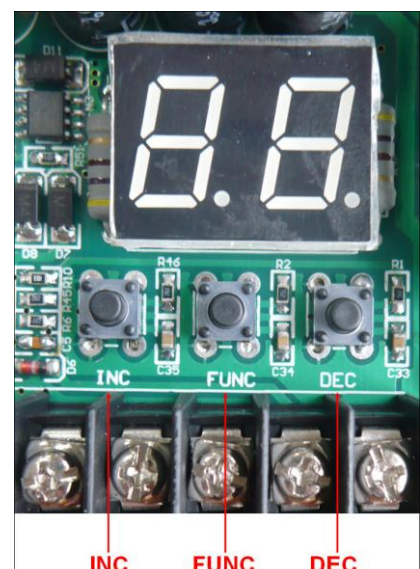

3. Master/Slave Gate Set

When Digital Display indicates "P2", the gate opener is on the Master/Slave Gate Setting. Press the "INC" and "DEC" Buttons respectively to follow modes:

"01" shown in Digital Display, which means Gate Opener 1 (right-hand side) as Master one

"10" shown in Digital Display, which means Gate Opener 2 (left-hand side) as Master one

Press the "FUNC" button to store the data when the master/slave gate is chosen. The Digital Display will indicate "P3". Now Master/Slave Gate Set is finished. (factory set is "01")

4. Set the Open Interval Set between Master and Slave Gate

When the Digital Display indicates "P3", the gate opener is on the Open Interval between Master/Slave Gate Setting.

The open interval can be adjusted by pressing the "INC" and "DEC" Buttons respectively. The Digital Display will show "0-9", which indicates the interval time "0" is the Master and Slave gates open simultaneously. "1" means the Master Gate starts to open 1 second before Slave gate. Maximum start time is 9 second. Each time you press and release the "INC" button, the figure increases by 1, and the Master gate starts to open 1 more second earlier. Each time you press and release the "DEC" Button, the figure decreases by 1, and the start time decreases 1 second.

(Factory set is 3 seconds)

Press the "FUNC" button to store the data when the open interval is set. The Digital Display will indicate "P4". Now Open Interval Set is finished.

5. Set the Close Interval between Master and Slave Gate

When the Digital Display indicates "P4", the gate opener is on the Close Interval between Master/Slave Gate Setting.

The Close Interval can be adjusted by pressing the "INC" and "DEC" Buttons respectively. The Digital Display will show "0-9", which indicates the interval time "0" is the Master and Slave gates open simultaneously. "1" means the Slave Gate starts to close 1 second before Master gate. Maximum start time is 9 second. Each time you press and release the "INC" button, the figure increases by 1, and the Slave gate starts to close 1 more second earlier. Each time you press and release the "DEC" Button, the figure decreases by 1, and the start time decreases 1 second.

(Factory set is 3 seconds)

Press the "FUNC" button to store the data when the Close Interval is set. The Digital Display will indicate "P5". Now Close Interval Set is finished.

6. Adjust the Obstruction Sensitivity/Stall Force

When the Digital Display indicates "P5", the gate opener is on the Stall Force Adjustment.

Without a properly installed safety reversal system, person (particularly small children) could be SERIOUSLY INJURED or KILLED by a closing gate.

*Too much force on gate will interfere with proper operation of safety reversal system.

*NEVER increase force beyond minimum amount required to close gate.

*NEVER use force adjustments to compensate for a binding or sticking gate.

* If one control (force or travel limits) is adjusted, the other control may also need adjustment.

* After ANY adjustments are made, the safety reversal system MUST be tested. Gate MUST BE TESTED. Gate MUST reverse on contact with a rigid object.

The opener is equipped with an obstruction sensing feature. If the gate encounters an obstruction the opener will automatically reverse direction and stop. Based on the length and weight of the gate it may be necessary to make force adjustments. The force adjustment should be high enough that small objects such as branches or wind will not cause nuisance interruptions but low enough to prevent serious injury to a person or a vehicle.

6-a Adjust Stall Force of Gate Opener 1

Now we adjust the stall force of gate 1

The stall force of gate opener1 is adjusted by pressing “INC” and “DEC” Buttons respectively. The Digital Display will show “1” –“9” which indicates the stall force level.”1” is the minimum force, and “9” is the maximum force. Each time you press and release the “INC” button, the figure increase by 1, and the force increases to a higher level. Each time you press and release the “DEC” button, the figure decreases by 1, and the force decreases to a lower level. Press “FUNC” to store the data. The Digital Display will indicate “P6”. Now stall force of gate opener 1 is finished.

(Factory set is Level 3)

6-b Adjust Stall Force of Gate Opener 2

When the Digital Display indicates “P6”.you can adjust force of gate opener 2.

Please perform the same procedure same as gate opener 1. (5-b)

Press the “FUNC” button to store the data when stall force of gate opener2 is set. Then “P7” will be shown on the Digital Display.

NOTE: You may need to increase the stall force in cold weather due to increased resistance from gate hinges. The gate opener’s open/close force is adjusted automatically according to stall force adjustment.

7. Adjust the TIMER-TO-CLOSE (TTC) for gate opener

The TIMER TO CLOSE feature can be set to automatically close the gate after a specified time period. The gate opener will be stop to move during open if the running time exceeds the specified time.

7-a Adjust the TTC of gate opener 1

When the Digital Display indicates “P7”, the gate opener enter Timer –to –Close adjusting mode

The TTC of gate opener 1 is adjusted by pressing “INC” and “DEC” Buttons respectively. The Digital Display will show “1” –“60” which indicates the TTC time from 1 to 60 seconds.

You can press hold the INC or DEC button exceeds 1 second to speed up your set until the design time is set .Press the “FUNC” button to store the data when the TTC of gate opener 1 is adjusted. The Digital Display will indicate “P8”.

(Factory set is 30 seconds)

7-b Adjust the TTC of gate opener 2

When the Digital Display indicates “P8”, you can adjust TTC of gate opener 2.

Please perform the same procedure same as gate opener 1 (7-a)

Press the “FUNC” Button to store the data when TTC of gate opener2 is adjusted. The Digital Display will indicate “P9”. Now Gate Opener 2 adjustment is finished.

8. Set the safety Photocell Beam System (PBS) (Optional)

When the Digital Display indicates “P9”, the gate opener enters PBS set mode.

You can press and release the “INC” or “DEC” Buttons to set or close the PBS function. The Digital Display indicates “11”, the PBS is available. The Digital Display indicates “00”, the PBS is null.

Note: If the “11” is be set, the gate opener won’t work until the PBS system is equipped. The PBS system works only when gate opener is closing. The gate opener will return to its open position when the obstruction blocks the beam from photo eye.

Press the “FUNC” button to store the data when the SPB is set. The Digital Display will indicate “PA”.

(Factory set is “00”)

9. Set the automatic closing time:

When the Digital Display indicates "PA", the gate opener enters into the setting the automatic closing time mode. Press and release the "INC" or "DEC" Buttons, the Digital Display will show a "1"- "9" which indicates the current automatic closing time. The minimum time is 1 minute, 9 minutes maximum. Each time you press and release the "INC" Button, the figure increases by 1, and the timing increases by 1, and the time increases by one minute. Each time you press and release the "DEC" Buttons, the figure decreases by 1, and the timing decreases by 1 minute. When the timing is 0, it means the automatic closing function is closed.

(Factory set is 6 minutes)

Press the "FUNC" button to store the data when the desired automatic closing time is set. The Digital Display will indicate "Pb"

10. To set the Period of Soft Start

When the Digital Display indicates "Pb", the unit is ready for setting Period of soft start.

You can press the "INC" or "DEC" Buttons to set the period of soft start. There is 1-9 second available for setting. Press the "FUNC" button to store the data when the Period is set. The Digital Display will indicate "PC".

(Factory set is 3 seconds)

11. Program your Opener & Remote



WARNING: Activate the opener only when door is in full view, free of obstruction and properly adjusted. No one should enter or leave gate area while door is in motion. Do not allow children to operated push button or remote. Do not allow children to play near the door.

Your swing gate opener receiver and remote control transmitter are set to a matching code. If you purchase additional remote controls, the gate opener must be programmed to accept the new remote code.

When the Digital Display indicates "PC", you can program your Opener & Remote.

Press and release "INC" button, the Digital Display will indicate "Ln". Press the key twice on the Remote Control, the "PC" will be show on the Digital Display after "Ln" flashing 4 seconds, now the opener has learned the code.

Repeat the above steps. The Opener can learn up to six remote codes.

If no other setting is to be programmed right now, press and release "FUNC" BUTTON to store the data. The Digital Display will indicate "Pd".

Caution: If you lose one of any remote control, please learn all other remote controls to have a new code for safety.

12. Erase All Remote Control Codes

When the Digital Display indicates "PC", press and hold the "DEC" Buttons more than 4 seconds, the all codes in remote will be erased, Digital Display indicates "dL". Then press and release "FUNC" button to let the Digital Display indicating "PC", now you can learn new code again.

13. Return to Factory set

When the Digital Display indicate "Pd", Press and hold the "INC" Button more than 4 seconds, the all data will return to factory set, the Digital Display indicates "dF".

14. If all of data is set and no any change needed, press "FUN" Button, "- -" be shown on the Digital Display, the unit enters standby.

Indicate Illustration on the Digital Display When Gate Opener is Running

The left mark on Digital Display symbolizes motor of gate opener 1 when the gate opener is running. The right mark on Digital Display symbolizes motor of gate opener 2.

When the motor is run to gate -open direction or gate -close direction, the mark on Digital Display indicates “n” or “u” respectively.

When the motor is running, the Digital Display indicates “-”.

When Gate Opener 2 is set as Master gate (i.e. when “10” indicated at P2 set mode in the Control Board), the Digital Display flashes “-n” before TTC time is up.

Adjust the Limit Switch

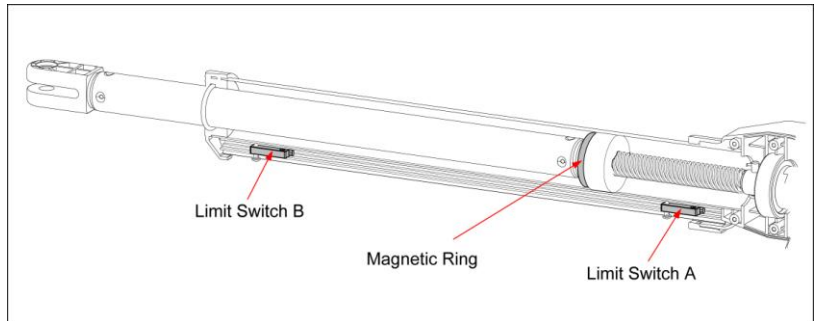

Step 13

Adjust the Limit Switch of Arm 1

Pull Gate 1 to its fully open position. Use a cross point screwdriver to unscrew Limit Switch A and slide it to the desired position. Then fix the Limit Switch A.

Pull Gate 1 to its fully closed position. Use a cross point screwdriver to unscrew Limit Switch B and slide it to the desired position. Then fix the Limit Switch B.

Limit setting for Gate 1 is finished.

NOTE: Always place the magnetic ring between the Limit Switch A and B.

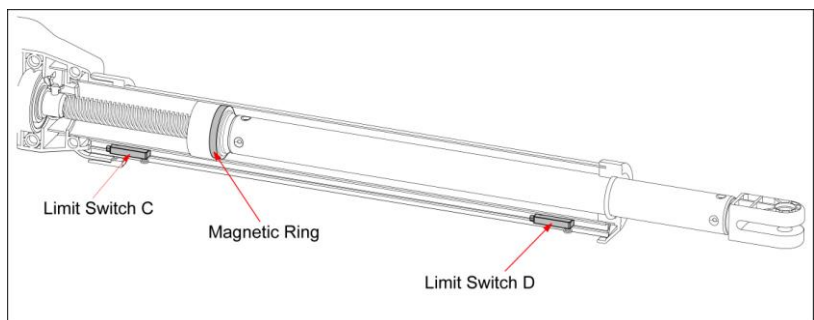

Step 14

Adjust the Limit Switch of Arm 2

The adjusting procedures are similar as in Step 13.

Pull Gate 2 to its fully open position. Use a cross point screwdriver to unscrew Limit Switch C and slide it to the desired position. Then fix the Limit Switch C.

Pull Gate 2 to its fully closed position. Use a cross point screwdriver to unscrew Limit Switch D and slide it to the desired position. Then fix the Limit Switch D.

Limit setting for Gate 2 is finished.

NOTE: Always place the magnetic ring between the Limit Switch C and D.

Usually the Limit Switch A and C near the motor are well adjusted. The user adjusts Limit Switch B and D as necessarily. The adjustment meets most users' requirement on the stroke during gate opening/closing. Shut OFF the power source first if the user needs to adjust the Limit Switch A and C. Turn ON the power after the adjustment. Allow the moving rod to automatically extend out, making sure the magnetic ring in the moving rod is always between both Limit Switches.

NOTE: The magnetic ring in the moving rod can be manually placed between both Limit Switches in each actuator. See Page 22 Emergency Release.

How to Operate

The user may operate the opener once all adjustment setting is finished.

With the gate at its closed position, press and release the remote control, the gate will move to the programmed opening position and stop.

With the gate at its opened position, press and release the remote control, the gate will move to the programmed closing position and stop.

While the gate is moving, press and release the remote control, the gate will stop moving immediately.

The next command from the remote will reverse the gate direction and the gate will stop at its programmed opening/closing position.

The gate will stop in case of obstruction during opening. The command from the remote control will reverse the gate direction and the gate will stop at its programmed closing position.

The gate will reverse in case of obstruction or stall force during closing, and it will move to the programmed opening position.

NOTE: The Obstruction Sensitivity /Stall Force is adjustable in 9 levels.

Emergency Release

In case of the system failure or power cut-off, the gate can be manually opened.

Insert the triangular key inside the triangular plug located on the bottom of actuator body, and then turn counter-clockwise till the stop. Motors shall be unlocked. The inverse operation restores the gate automation.



Accessories Connection (Optional)

There is connection wire Terminal on the PCB board in the control box.

The function is as follows:

(1) BAT(+) BAT(-) for back up battery

The user can connect backup battery (optional) by both BAT (+) and BAT (-) terminals.

By installing a 24V/5AH battery (optional), the SWING GATE OPENER will be possible to carry out approx. 50 emergency operations without power supply. The battery should be always connected to the terminal to keep it charged. Before using the system with only the battery it shall be first charged for at least 24 hours.

* If more operation cycles are required during power failure, the user may choose battery of bigger capacity.

* The user may use a solar panel (optional) to maintain charging the battery power even there is no power supply.

(2) O/S/C for Push Button

The user can connect push button (optional) by both terminals. The push button can be installed at any safety place you prefer, so that the user may open/close the gate conveniently.

(3) Alarm Lamp

This device is foreseen by all safety EEC norms, and it has to be installed in a visible position.

The device operates at LOW VOLTAGE and a 24V 10W Bulb.

Caution: Never exceed this power as there might be the risk of damaging circuits.

Operation: The intermittent signal comes from the control unit. The activation starts 2 seconds before each operation.

The blinking is slow when the gate opens or closes and faster when gate stop/reverse in case of obstruction.

(4) Solar Panel

The solar panel should be connected with the back up battery directly and it should not be installed before the back up battery is installed. With the solar panel, the back up battery can be charged both by the control box from AC power and directly by solar panel.

The 30W solar panel consists of three 10W panels by parallel connection.

The 5AH battery (LM125/5) is standby power source, which is recommended for use where power failure is rare. When equipped, please use the 5AH battery adaptor (LM135).

The 5AH battery with 10W solar panel (LM109) is also standby power source, which is recommended for use where power failure is frequent. When equipped, please do use the 5AH battery adaptor (LM135/5).

The 12AH battery (LM125/12) with 30W solar panel (LM109) can be used as main power source, which is recommended for use where AC power is unavailable. When equipped, please do use the 12AH battery adaptor (LM135/12).

The provided battery is 12 volt each cell. The user is required to connect two 12V battery cells in series to function as a 24V standby power source.

Directly connecting the wires from the actuator (motor) to other power source is forbidden.

Connect the 24V battery directly with the PCB. Refer to Page 17 Connecting Opener Power Cables.



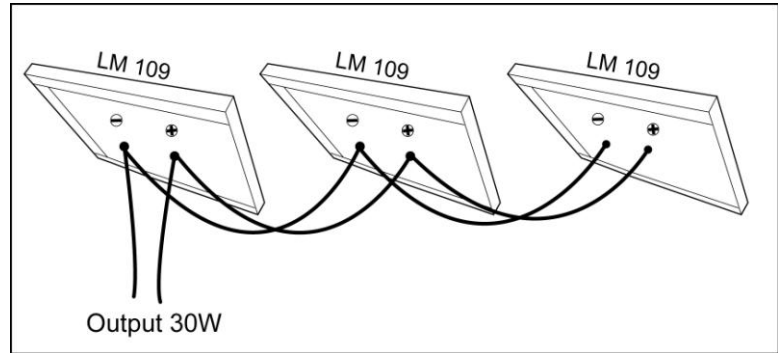
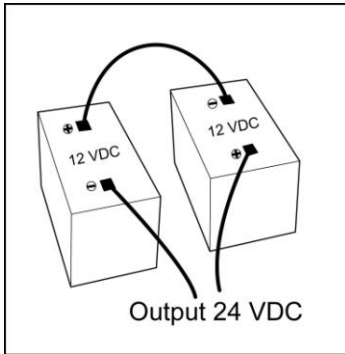

NOTE:

The positive terminal of the solar panel should be connected to the positive terminal of the battery and vice versa.

The bigger capacity of the batteries is, the longer the system will operate in cloudy days.

The solar energy conversion efficiency may vary with installation places and weather conditions.

Install the solar panel in open area clear of obstructions such as tall trees and buildings which probably block the sunlight.

The solar panel should be installed with its surface facing with the most sunshine, south-facing in northern hemisphere and north-facing in southern hemisphere.

Installation for Push-to-Open Gates

 Ensure the gate does not open into public areas.

In a Push-to-Open installation, gate opens out from the property. A Push-To-Open Bracket (PSO part) is required to be used for each gate. The gate is in the closed position during the opener is installed.

Step 1

Place the PSO bracket between the two post brackets. Insert the M10x30 bolt through the center hole of the post bracket and PSO bracket as shown. Place a ϕ 10 washer, ϕ 10 lock washer and M10 nut on the bottom of the bolt and hand tighten.

Step 2

Attach the gate bracket and post bracket assembly to the opener by inserting a clevis pin. Secure the clevis pins using the hairpin clips.

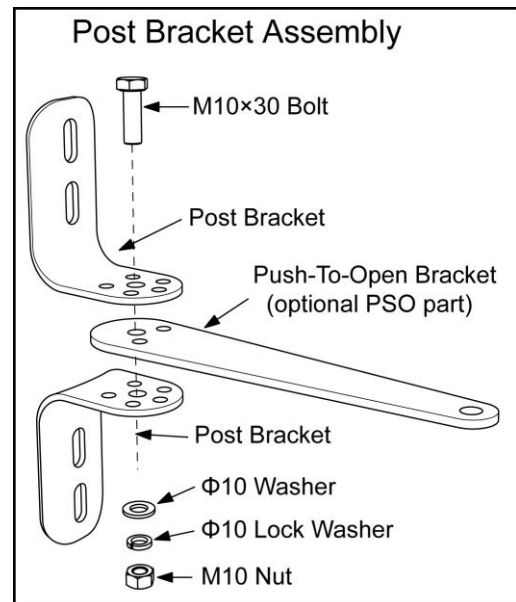

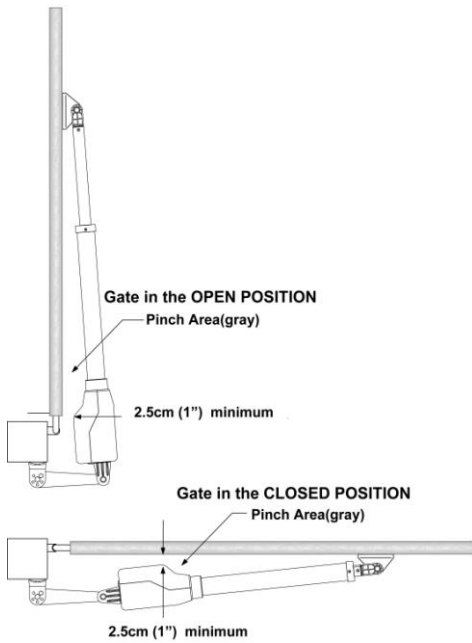

Step 3

With the gate in closed positions and with the opener in their retracted positions, place the opener with the gate bracket and post bracket assembly on to the gate post and the gate. Position the gate bracket and the post bracket assembly so that the gate opener is level with the horizontal cross member of the gate. While holding the opener in the desired level position, temporarily secure with two C-clamps.

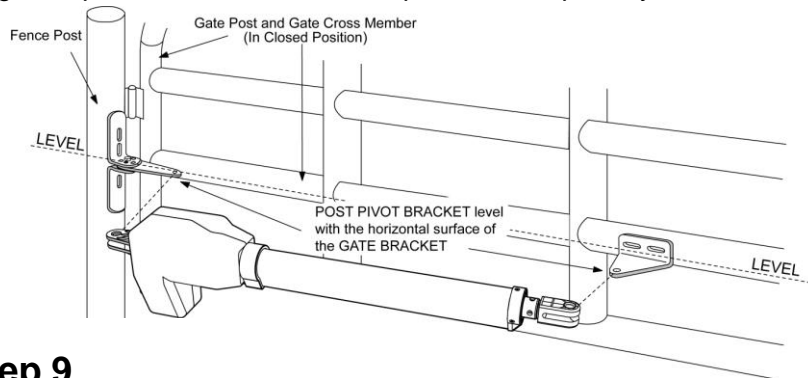

Step 4 to Step 9

Repeat the Step 4-9 in P 11-13.

Step 10

The motors' power wires and limit wires connection by "Push to Open" is different from the connection by "Pull to Open". So motor 1 and motor 2 wires should be connected to the control box as the instruction in the right, not according to the instructions in page 16.

Black thick wire should be inserted into the Motor+ terminal. Red thick wire should be inserted into the Motor- terminal, the Yellow wire into ULT1 terminal and the Red wire into DLT1 terminal. Black wire is still into COM terminal.

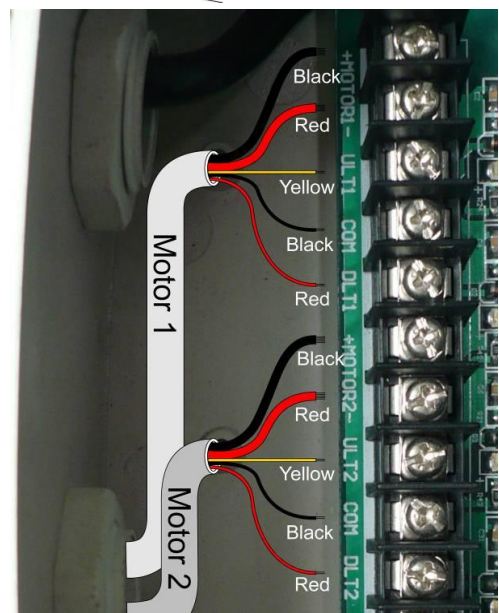

Maintenance

 **Warning:** *Disconnect power before servicing.*

1. Using a clean, dry cloth, wipe the gate opener shaft, and then apply a silicone spray to reduce its friction. In cold climates where temperatures reach 1°C (30°F) or less, spray silicone on the actuator arm every 4-6 weeks to prevent freeze up.
2. Regularly check gate hinges to make sure gate is swinging smoothly and freely. Grease hinges if needed.
3. Check your installation periodically, as hardware and posts will shift. Brackets may need to be adjusted or hardware may need to be tightened.
4. Maintain the area around your gate. Keep the areas free of objects that can prevent the gate swinging freely.

NOTES:

1. *Inspection and service should always be performed anytime a malfunction is observed or suspected.*
2. *It is suggested that while at the site voltage readings be taken at the operator. Using a Digital Voltmeter, verify that the incoming voltage to the opener is within ten percent of the opener's rating.*
3. *Refer to page 18 for instructions on how to check gate force and sensitivity adjustments.*

Trouble Shooting

1. Opener does not run. Digital Display indicator is not on.
 - Check if all motor are properly connected and color coded. Make sure the AC input is connected.
 - Check if the fuse in control board is bad.
2. Opener powers up but does not run.
 - Arm cable loose or disconnected. Verify that all of the wires going to the arm are secure and that the connector is properly mated to the header.
 - Arm is incorrectly installed. Disconnect the motor housing from the arm and verify that the arm moves freely.
 - Gate is excessively heavy or hinges are bad. Verify that the gate is within the ratings for this product. Disconnect the arms and verify that both gates swing easily. Lubricate or replace hinges as necessary.
 - Bad control board. Call technical support for help with replacement parts.
3. Gate stops immediately after it starts moving.
 - Obstruction sensed. Check safety devices and gate for obstructions.
 - Force set too low. Adjust FORCE setting until gate completes a full open/close cycle without stop. The force setting may need to be adjusted in cold weather, as the gate will not move freely.
 - Check if the TTC period is too short. Refer to page 19.
 - Incorrect power.
4. Gate opens but does not close.
 - Photocell (PBS) is set in Control Board but is not equipped (optional). Please cancel the PBS set. Refer to page 19.
 - Obstruction blocking close photo eyes, Check eyes for alignment and verify all connections and operation for safety devices.
5. Gate ignores the limit switches
 - Check that the limit switch is not faulty

- Check that wires to the limit switch are not shorted.
 - Ensure that the motor cable is away from sources of electrical interference, such as electric fences, power lines etc.
6. Gate opens, closes or stops on its own
- Ensure that the key for manual release is in the lock position. Refer to page 22.

Quick-Setting Guide



SWING GATE OPENER

Quick-Setting Guide

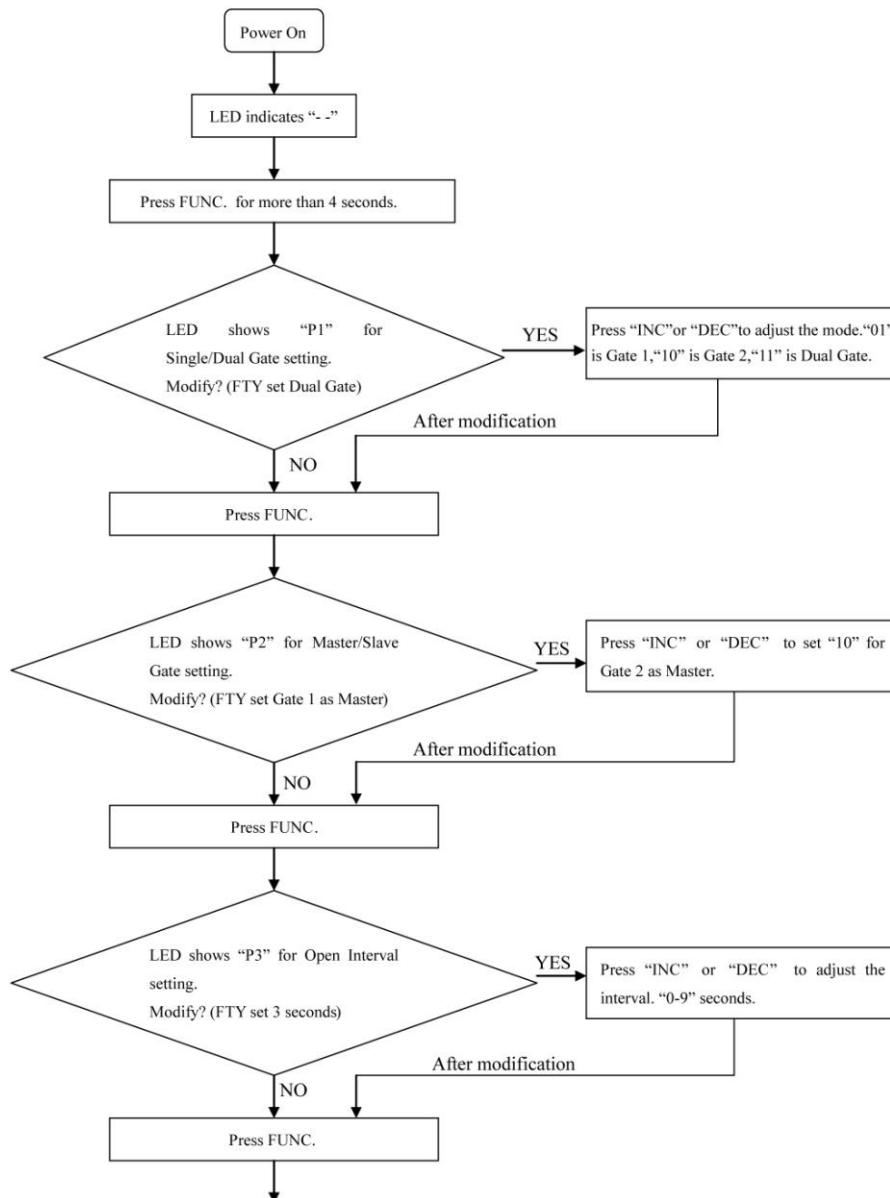

To be continued...

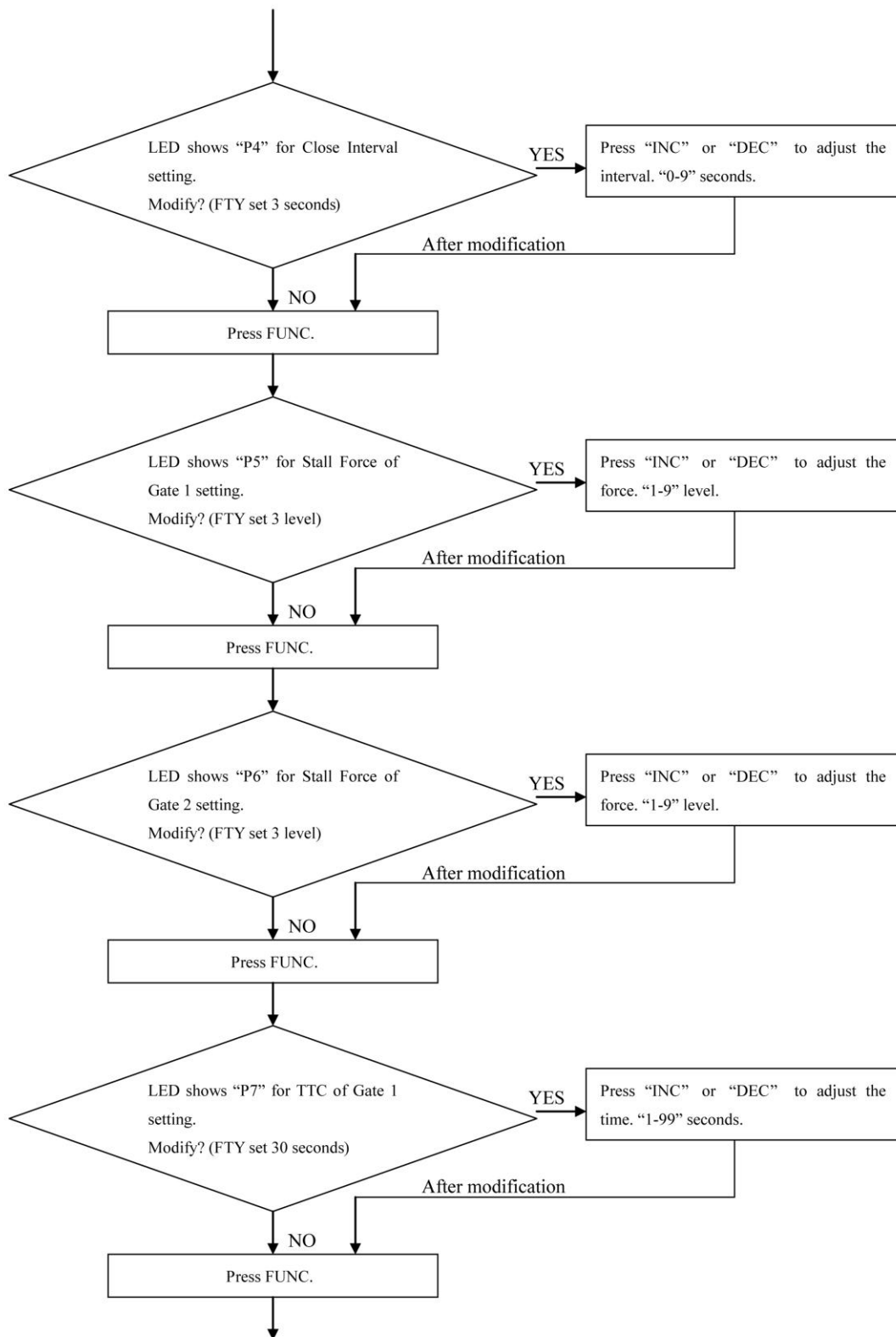

To be continued...

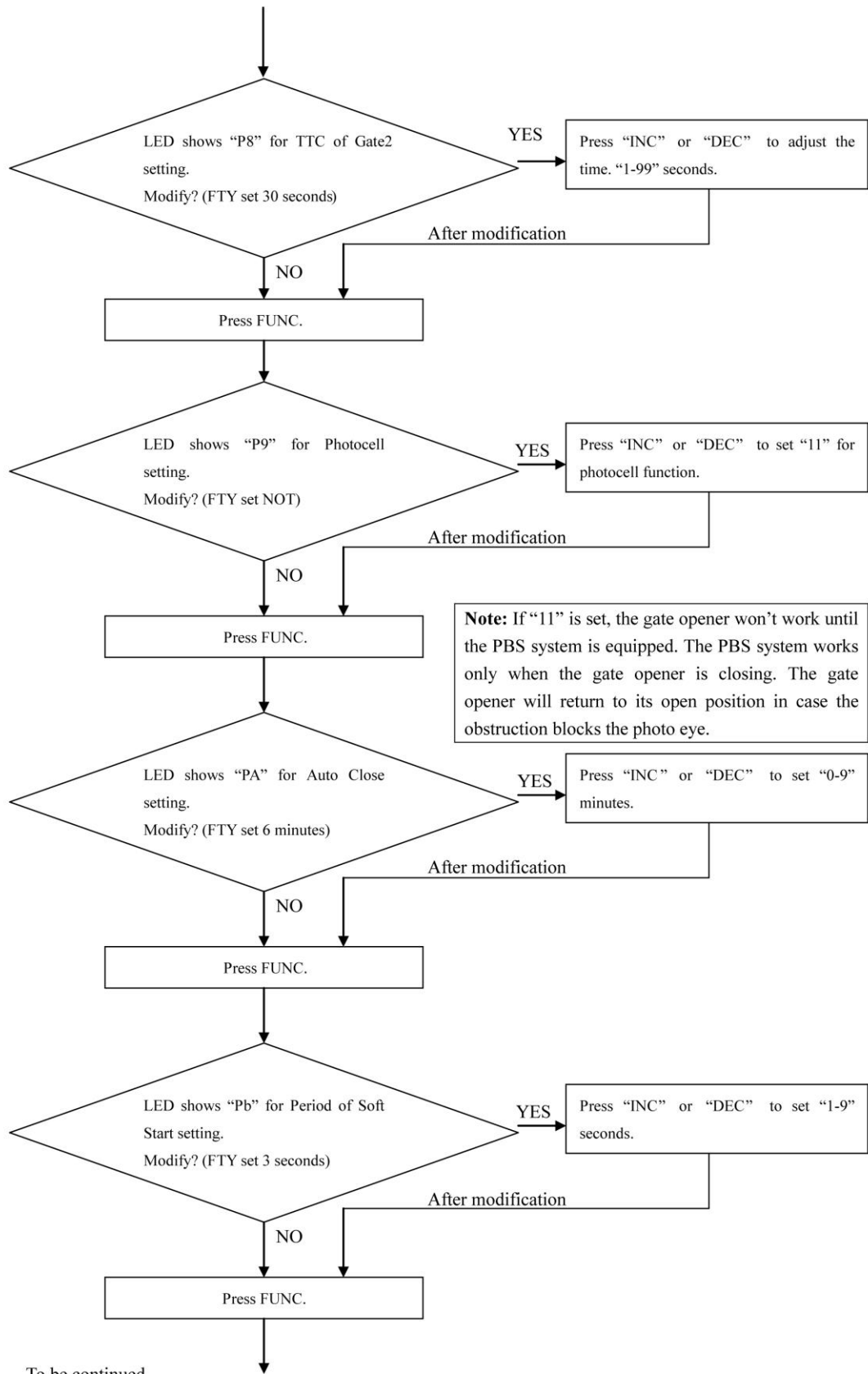

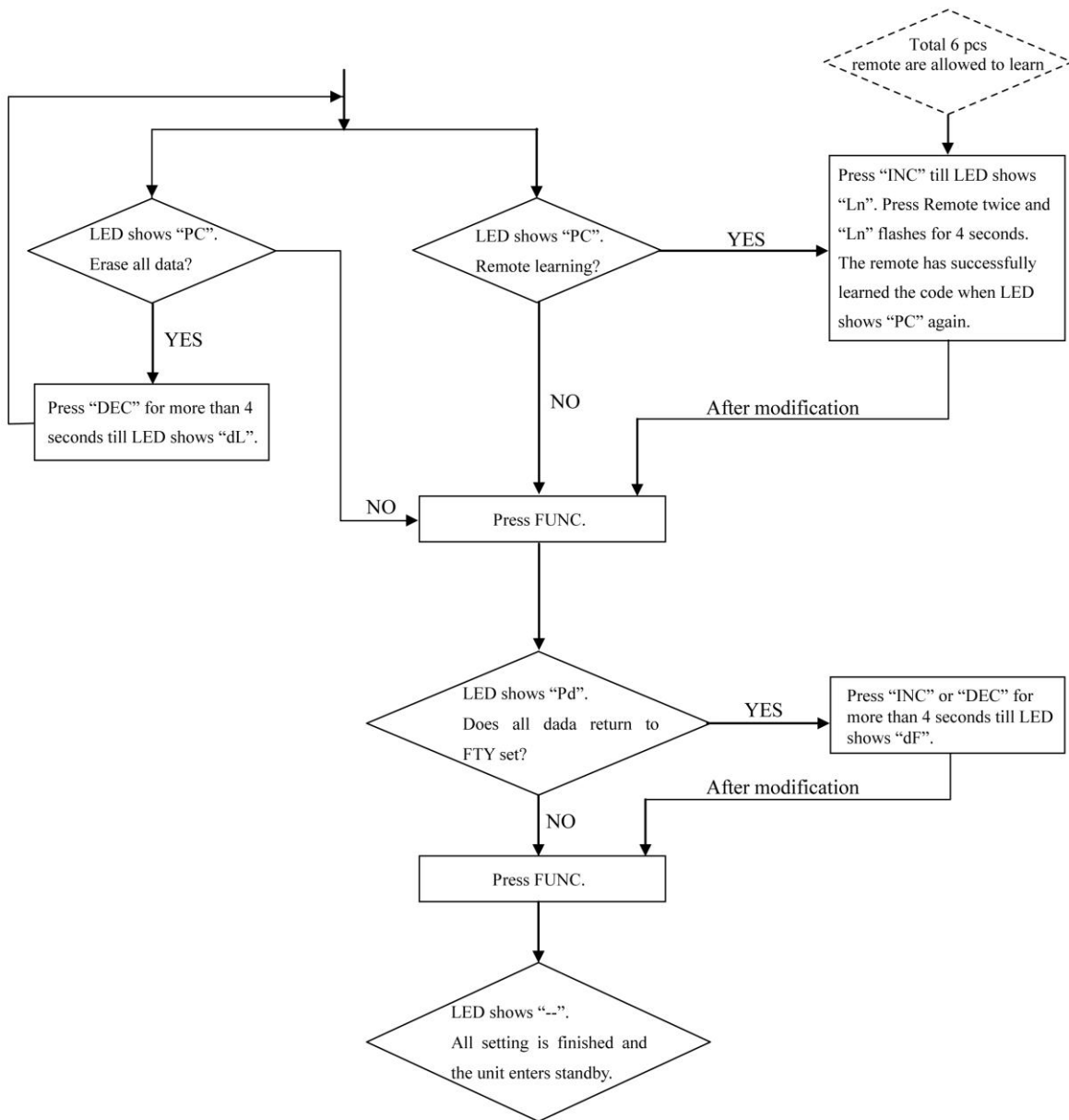

IMPORTANT NOTICE TO USERS:

To maintain the proper working condition of your new automatic gate opener, we recommend that you spray the actuator shaft every two weeks with silicone. This will keep the actuator working freely and prevent problems.

FCC Note:

The manufacturer is not responsible for any radio or TV interference caused by unauthorized modifications to this equipment. Such modifications could void the user's authority to operate the equipment.

This device complies with Part 15 of the FCC Rules.

Operation is subject to the following two conditions:

1. This device may not cause harmful interference, and;
2. This device must accept any interference received, including interference that may cause undesired operation.

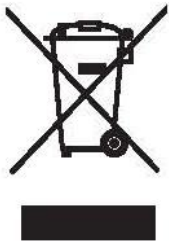

According to Waste of Electrical and Electronic Equipment (WEEE) directive, WEEE should be separately collected and treated. If at any time in future you need to dispose of this product please do NOT dispose of this product with household waste. Please send this product to WEEE collecting points where available.

