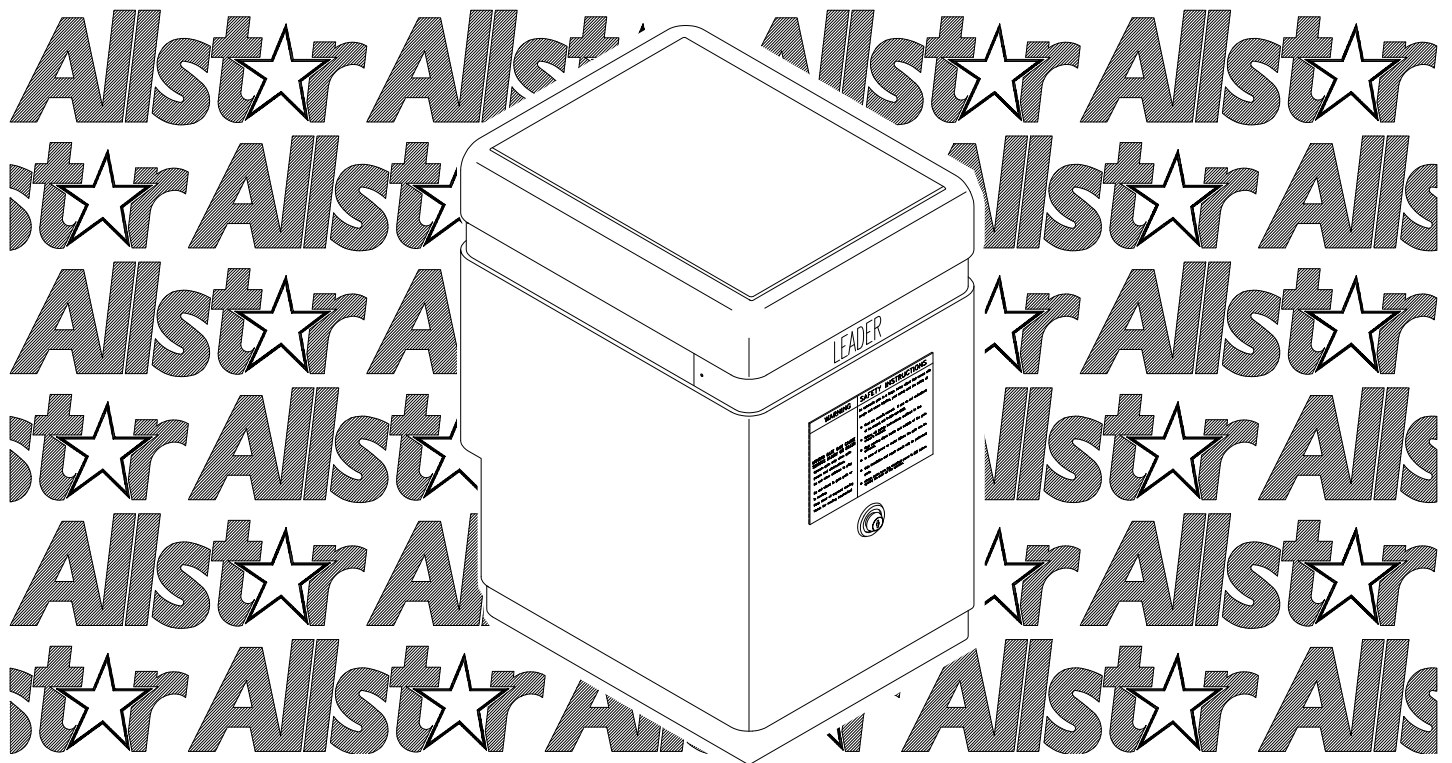


INSTALLATION AND OWNER'S MANUAL

LEADER PLUS

*Model LPX1000 Series - Heavy Duty
Vehicular Slide Gate Operator*



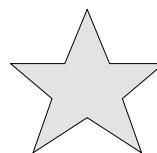
107063



**PROVEN
CGA2K™
TECHNOLOGY!**

Serial #:
Date Installed:
Your Dealer:

As of date of manufacture meets
all ANSI/UL 325 Safety
Requirements for Vehicular gate
operators.



**READ THIS MANUAL
CAREFULLY BEFORE
INSTALLATION OR USE**

SAVE THESE INSTRUCTIONS

2 | TABLE OF CONTENTS



Pre-Installation Notes.....	3	Setting the Obstruction Detection.....	16
Operator Class Designation	3	Setting the Switch Selectable Options	17
Section A: Gate System Design/Installation.....	4	No Load Test Mode	17
Section B: Preparing the Site.....	6	Timer To Close Setting	17
The Concrete Operator Pad	6	Section D: Starting the Operator.....	18
Electrical Power Requirements	6	Indicator Lamps.....	18
Placing the Vehicle Detector Loops	8	Final Setting of Limit Switches	19
Section C: Installing the Operator	9	Final Setting the Close Timer.....	19
Attaching the Chain Bracket.....	9	Final Setting - Obstruction Detection.....	19
Placing the Leader.....	9	Testing the Operator Lock	19
Electrical Hookup.....	9	Maximum Run Timer (SMART).....	19
Additional Lightning Protection Information.....	9	Final Setting - Bi-Parting Installation	20
Control and Accessory Equipment Wiring	10	Terminal Strip Reference Chart	20 & 21
Bi-Parting Application	10, 17, 20, & 21	Wiring Diagram.....	22
Optional Photoelectric Thru Beam Sensor	11	Testing the Vehicle Loop Detectors.....	23
Optional Photoelectric Retro-Reflective Sensor ...	12	Section E: End User Instructions	23
Optional Electric Edge Sensor	13	Operational Guide for the End User.....	24
Wiring the Vehicle Detectors	14	Manual Operation of Gate	24
Wiring a 3 Button Station / Access System	14	Safety Guide for the End User	25 & 26
Left or Right Hand Installations	15	Replacement Parts View & Listing	27
Setting the Limit Switches	16	Technical Specifications	28

WARNING HIGH VOLTAGE				<i>Figure 1</i>
ONLY A QUALIFIED TECHNICIAN SHOULD SERVICE THIS GATE OPERATOR				
PERIODICALLY TEST SENSITIVITY OF OVERLOAD *** READ MANUAL ***				
LOG DATE OVERLOAD TEST				DATES OPERATOR SERVICED
DATE TESTED	DATE TESTED	DATE TESTED	DATE TESTED	



READ THESE STATEMENTS CAREFULLY AND FOLLOW THE INSTRUCTIONS CLOSELY.

The Warning and Caution boxes throughout this manual are there to protect you and your equipment. Pay close attention to these boxes as you follow the manual.

WARNING

Indicates a MECHANICAL hazard of INJURY OR DEATH. Gives instructions to avoid the hazard.

CAUTION

Indicates a MECHANICAL hazard of DAMAGE to your gate, gate operator, or equipment. Gives instructions to avoid the hazard.

WARNING

Indicates an ELECTRICAL hazard of INJURY OR DEATH. Gives instructions to avoid the hazard.

CAUTION

Indicates an ELECTRICAL hazard of DAMAGE to your gate, gate operator, or equipment. Gives instructions to avoid the hazard.



The LPX1000 Vehicular Gate Operator will provide convenience and assurance to the ultimate users for many years. It is ruggedly built of the finest materials and has been thoroughly inspected and tested at the factory. It has many features that will aid in the installation and testing of the complete gate system. The LPX1000 is certified to comply with the ANSI / UL Standard for Safety 325.



NOTICE

Before attempting installation, read this manual carefully so you will be thoroughly familiar with the features of the LPX1000 and its proper installation procedures.

The LPX1000 slide gate operator (models without suffix or with suffix "S" only) is designated a Class I Residential Vehicular Slide Gate Operator and is intended to operate a vehicular slide gate installed on a residential home, maximum of four single families in the dwelling, or a garage or parking area associated with such a home. The LPX1000 vehicular gate operator (again models without suffix or with suffix "S" only) is also designated as a Class II Vehicular Slide Gate Operator for use in a commercial location or multi-family home. The LPX1000 vehicular gate operator (all models) is also designated as a Class III (industrial location not intended to service the general public); and IV (secure or restricted access locations, i.e. airports and prisons). **THE LPX1000 (with appropriate suffix) MAY BE USED IN ANY CLASS LOCATION.**

Because the LPX1000 (as well as gate operators sold by other manufacturers) is designed to start and move gates weighing as much as 1300 pounds, or more, the LPX1000 is capable of producing high levels of force. It is important in the design of the total gate system that designers, installers and users be aware of the hazards that may be associated with the **IMPROPER** design, installation and use of vehicular gate systems and gate operators.

The gate operator is only one part of a complete automatic gate operating system. As each location and usage is different, a properly designed system will include all applicable safety devices.

As the designer and installer of the GATE SYSTEM, you must advise the purchaser on the proper use of the gate system.

The LPX1000 has exclusive CGA2K™ Technology that provides several features to help reduce the hazards of your gate system.

Built-In Overload Detector Sensing System

The LPX1000 has a built-in "overload detector" that can help reduce the hazards of your gate system. This device, however, must not be considered as the primary defense system. Consider all available options (electric leading edges, photoelectric sensors, protective screen mesh, etc) to eliminate hazards in your gate system design.

The LPX1000's built-in overload detector will activate if there is an abrupt increase in motor current above that normally required to move the gate. The overload detection point is an adjustable setting that must be determined at the time of installation. This setting must be tested periodically to ensure proper operation. Diligent maintenance of the gate hinges and hardware will assure the most responsive operation of the overload detector. See pages 16 and 19.

ADVISE THE PURCHASER TO CHECK THE SENSITIVITY OF THE OVERLOAD PERIODICALLY AND, AFTER REMOVING THE CONTROL BOX COVER, LOG THE DATE TESTED ON THE LOG LOCATED ON PAGE 2 OF THIS MANUAL (See Figure 1, pg. 2.)

Connections for External Entrapment Prevention Sensors

Because all gate system installations are different, the LPX1000 control panel provides independent connections for Open and Close non-contact (photoelectric) and contact (edge) sensors. In this way a photoelectric sensor could be utilized to guard the gate area when closing and an edge sensor would provide the protection when opening. Depending on the particular application a combination contact and non-contact sensor protection system for the open and close directions may provide more effective entrapment protection than a single device for both directions. See pages 4, 5, 11, 12, 13, 21, 25, and 26..



NOTICE

The important safeguards and instructions in this manual cannot cover all possible conditions and situations which may occur during its use, It must be understood that common sense and caution must be exercised by the person(s) installing, maintaining, and operating the equipment described herein. Do not use this equipment for other than its intended purpose - operating a vehicular slide gate.

Audio Alarm and Safe Secure™ Open/Close Push Button Enable-on-Alarm Only (Patent No. 6,611,205)

The LPX1000 has an audio alarm that sounds when a second occurrence of the built-in overload activation is registered before an end limit (open or close) is reached. The alarm continues to sound warning until a fixed wire input is activated or five (5) minutes pass. As with the built-in overload detector, diligent maintenance of the gate rollers and track will avoid nuisance operation of the overload detector and thereby avoid nuisance operation of the audio alarm. The Safe Secure™ Open/Close Push Button Enable-on-Alarm Only feature can be set to provide a secure control station that will be functional in an emergency situation. See pages 17 and 21.

SMART™ Self adjusting MAXimum Run Timer

The LPX1000 has a Self adjusting MAXimum Run Timer, SMART™. The amount of time for the first few cycles of operation are registered and averaged within the motor controller circuitry. After the first few initial cycles, if the gate is activated and no other command is given or an end limit (open or close) is not reached in the previously counted cycle time plus approximately 2 seconds, the operator will be turned off. See page 19.

OTHER FEATURES

Optional Fail Secure Lock Mechanism: Models with -S suffix are equipped with a Fail Secure operator locking mechanism. The lock is active whenever the gate is not moving and must be released via the integral Solenoid Lock Lever to manually move the gate. See Page 24,

Auto Close Timer: Adjustable from 2 to 60 seconds, provides an automatic closure of the gate from the full open position. See page 17.

Timer Re-close On/Off Switch: Enables an automatic closure of the gate from a partially closed position if the close movement was initiated by the Auto Close Timer and the close cycle was interrupted by a non-contact (photoelectric) sensor input. See page 17.

Diagnostic LEDs on the Motor Controller Board: Provides a visual indication of the status of the gate system operation. See page 18.

Built-In Free Exit and Reversing Loop Detector Sockets: Two loop detector sockets are built-in and pre-wired to the operator's control system. Easily accessible terminals allow connection of the actual loop wires to the operator. See pages 7, 14, and 20.





WARNING!

TO REDUCE THE RISK OF SEVERE INJURY OR DEATH: READ AND FOLLOW ALL INSTALLATION INSTRUCTIONS AND GATE SYSTEM DESIGN PARAMETERS!

GATE SYSTEM DESIGN AND INSTALLATION SAFETY CHECK LIST:

- The LPX1000 operator may be installed on a Class I, II, III, or IV Vehicular Slide Gate. See page 3 for an explanation of the different Class locations. See the last page of this manual for the operator specifications (voltage, maximum gate weight & length etc.).
- Make sure that the gate moves freely, all rollers are in good working order, the gate does not bind in any manner and the gate area is clean and free of irregularities. **DO NOT INSTALL THE OPERATOR UNTIL ALL GATE PROBLEMS HAVE BEEN CORRECTED.**
- Do not increase the built-in overload detector adjustment to compensate for a poorly working gate. A well maintained gate will ensure easy manual operation (if needed) and maximum operator obstruction sensitivity.
- Install the operator on the inside of the property/fence line. **DO NOT** install an operator on the public side of the fence line or gate.
- Make sure the gate operating system is placed far enough back from the road to eliminate traffic backup. The distance from the road, size of the gate, usage level and gate cycle/speed must be taken into consideration to eliminate potential hazards.
- The gate must be installed in a location so that enough clearance is supplied between the gate and any adjacent structures when opening and closing to reduce the risk of entrapment.

104949



Figure 2

- For ORNAMENTAL “GRILL TYPE” GATES (or any other type of open gate where a handhold or toehold may be achieved), injuries may occur when people put arms through the openings or children “ride” the gate by standing on the bars and holding on to the gate. **THIS POTENTIAL HAZARD CAN BE MINIMIZED BY INSTALLING A MESH SCREEN ON THE GATE.** It is strongly recommended that the entire gate and adjacent fence area the gate covers when open be meshed or guarded such that a handhold or toehold cannot be achieved. At a minimum all openings on a horizontal slide gate must be guarded or screened from the bottom of the gate to a minimum of 4 feet above the ground to prevent a 2-1/4 inch (57.15 mm) sphere from passing through the openings anywhere in the gate, and in that portion of the fence the gate covers when in the open position. See Figure 2.
- All LPX1000 gate operators are **VEHICULAR GATE OPERATORS** and as such are **NOT INTENDED FOR PEDESTRIAN** traffic. In installations where pedestrian passage through the fence is necessary, install a pedestrian access opening. The pedestrian access opening shall be designed to promote pedestrian usage. Locate the vehicular gate and the pedestrian access opening such that persons will not come into contact with the vehicular gate during the entire path of travel of the vehicular gate. See page 15 for additional information.
- Install leading edge detectors and/or photocells in your design to protect system entrapment zones. These devices can be provided for incorporation in your gate system design.
- Use the illustration at left (Figure 3) and the information and diagrams on pages 11, 12, and 13 to minimize the risk of injury in your design of the swing gate operator system. **IDENTIFY THE ENTRAPMENT ZONES AND PINCH POINT AREAS IN YOUR GATE.** Design the gate installation to minimize the risk of entrapment in these areas. Install additional safety equipment such as four wire edges and photocells to further minimize risk. All entrapment zones are required to be protected.

106709

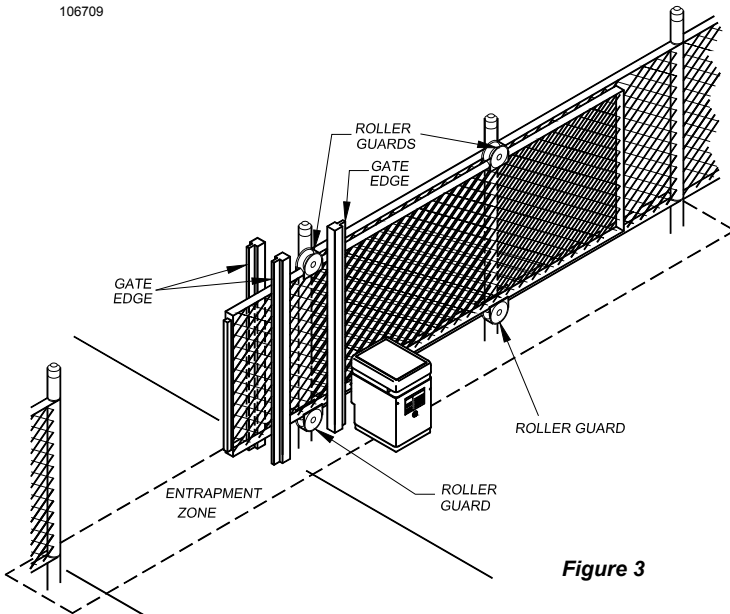


Figure 3



- **Entrapment Zones:** Design in personal entrapment protection devices to protect people from entrapment in the zones shown in Figure 3 and the information and diagrams on pages 11, 12, and 13. Install vertical posts with gate edges attached on both sides of the gate to prevent body entrapment.
- **Pinch Points:** Use protective measures (guards, padded edges, etc.) to protect people from the pinch points shown in Figure 3 and the information and diagrams on pages 11, 12, and 13. Attach roller guards in cantilevered gate systems to minimize the risk of hands being caught between the top of the gate and the roller.



ALL APPROPRIATE SAFETY FEATURES MUST BE INCORPORATED INTO YOUR GATE SYSTEM.

- DO NOT consider the built-in overload detector as the primary defense system. Consider all options in the gate system design.
- DO NOT connect any auxiliary equipment to the LPX1000 operator (detectors, card readers, etc.) until the gate operator and all its functions are fully tested. Only connect one device at a time and ensure its proper function(s) before moving on to the next device.
- DO NOT locate any control device (key switch, switch, key pad, card reader, etc.) in a position where it may be activated by a person reaching through the gate or while touching the gate in any manner. Locate all control devices a minimum of 10 feet from the gate when opened or closed.
- Outdoor or easily accessible controls must be of the security type to prevent unauthorized use of the system.
- Install all devices that will Open, Close or Stop the gate in such a manner that THE GATE WILL BE IN FULL VIEW WHEN THE DEVICE IS OPERATED.
- Before activating the "timer to close" option of the LPX1000, ENSURE THE PERSONAL ENTRAPMENT PROTECTION DEVICES (operator reversing feature, edges, photocells) ARE OPERATING and install VEHICLE DETECTOR LOOPS AND VEHICLE DETECTORS for protection of user vehicles. Read the manual for information on the installation of these devices. IF VEHICLE DETECTOR LOOPS HAVE BEEN INSTALLED TO PREVENT THE GATE FROM CLOSING ON A VEHICLE, INSTRUCT THE USER TO PERIODICALLY CHECK THE OPERATION OF THE DETECTORS.
- USE EXTREME CAUTION WHEN WORKING NEAR THE BELTS AND PULLEYS when the operator cover is removed. Apply power to the operator only when instructed to do so.
- When the outer cover of the LPX1000 and the handy box covers are removed, high voltage will be exposed. EVEN IF THE RED POWER LIGHT IS NOT LIGHTED, HIGH VOLTAGE AC IS STILL PRESENT. NEVER LEAVE THE INSTALLATION WITH THE HANDY BOX OR OUTER COVERS REMOVED.
- ALWAYS TURN OFF THE POWER BEFORE ATTEMPTING SERVICE OF EITHER THE ELECTRICAL OR MECHANICAL SYSTEMS.
- SECURELY ATTACH THE WARNING SIGNS provided with the LPX1000 on the gate (one on the outside and one on the inside) where they can be seen by persons in the area of the gate to alert them of automatic gate operation. (If the user refuses to have the warning signs installed, it is recommended that you note this on your records and have the user sign a disclaimer.) See Figure 4.



104880

Figure 4

AS THE INSTALLER YOU ARE RESPONSIBLE FOR:

- 1 ASSURING THAT THE GATE AND OPERATOR SYSTEM, WHEN FULLY INSTALLED AND OPERABLE, COMPLIES WITH ALL APPLICABLE REQUIREMENTS OF UL325: STANDARD FOR SAFETY FOR DOOR, DRAPERY, GATE, LOUVER AND WINDOW OPERATORS AND SYSTEMS.
- 2 ASSURING THAT THE OWNER/END USER OF THE SYSTEM UNDERSTANDS ITS BASIC OPERATION AND SAFETY FEATURES. IN PARTICULAR, BE SURE THE OWNER/END USER UNDERSTANDS THE LOCATION AND OPERATION OF A MANUAL DISCONNECT (WHERE PROVIDED) OR HOW TO OPERATE THE GATE .
- 3 YOU ALSO HAVE THE PRIMARY RESPONSIBILITY OF INSURING THAT ALL POSSIBLE OPERATIONAL HAZARDS HAVE BEEN CONSIDERED AND ELIMINATED. YOU MUST ADVISE AND WARN THE PURCHASER AND THE ULTIMATE USER OF ANY HAZARDS THAT YOU HAVE NOT BEEN ABLE TO ELIMINATE.
- 4 POINTING OUT TO THE OWNER/END USER OF THE GATE SYSTEM THAT CHILDREN OR PETS ARE NOT ALLOWED TO PLAY ON OR NEAR THE GATE, FENCE OR ANY PART OF THE SYSTEM, AND THAT THE SAFETY INSTRUCTIONS SUPPLIED WITH THIS OPERATOR AND THEIR IMPLEMENTATION ARE THE RESPONSIBILITY OF THE OWNER/END USER.
- 5 LEAVING THE INSTALLATION AND MAINTENANCE MANUAL FOR THIS OPERATOR AS WELL AS ANY ADDITIONAL SAFETY INFORMATION SUPPLIED WITH THIS OPERATOR OR OTHER COMPONENTS OF THE GATE SYSTEM WITH THE OWNER/END USER.
- 6 NOT PLACING IN SERVICE THIS OPERATOR IF YOU HAVE ANY QUESTIONS ABOUT THE SAFETY OF THE GATE OPERATING SYSTEM. CONSULT THE OPERATOR MANUFACTURER.

6 | B: PREPARING THE SITE



THE CONCRETE OPERATOR PAD

Installation requires the presence of a suitable concrete pad as a base for the operator. The dimensions of this pad should be at least 12" greater than the dimensional pattern of the operator mounting holes. The top of the pad should be 7" above grade to raise the operator above any standing water, while the depth of the pad below grade is dependent on the soil conditions at the installation site and the size of the gate. The LPX1000 cover is 24" high and is removed by lifting it vertically off the operator. THE SITE FOR THE OPERATOR SHOULD BE CHOSEN WITH AT LEAST 24" OF CLEARANCE ABOVE THE TOP OF THE UNIT.

If no suitable concrete base exists, a pad must be poured. After completing the gate installation, place the operator pad at the appropriate location as described in Figures 5 and 6. Consult local building codes for depth of base. Typical depths range from 24" to 36". In either case, if vehicles are going to be operated in the vicinity of the operator, consider installation of protective bollards in front of the operator.

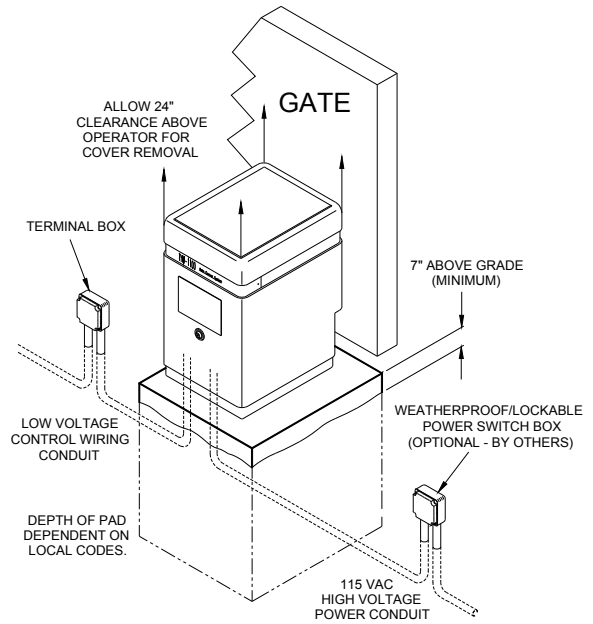


Figure 5: Pad Configuration

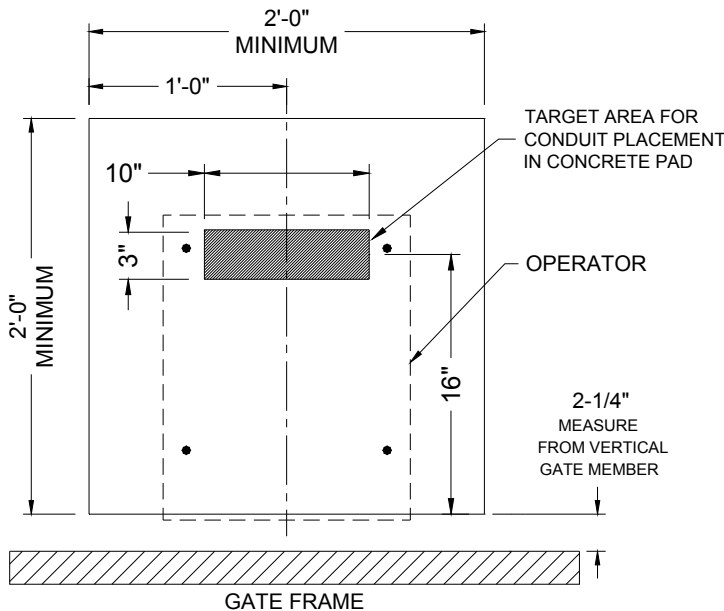


Figure 6: Operator Footprint

ELECTRICAL POWER REQUIREMENTS

NOTE: Before connecting the operator, use a voltmeter to insure that the electrical service is 115 VAC. Connection to 220 VAC service is the most common cause of board failure in new installations and is NOT covered by the warranty.

The LPX1000 requires a 3-wire (Hot, Common, Ground), 115 VAC, electrical circuit with a 15 Amp breaker for proper operation. In installations with more than one operator, each operator must have a separate service from the breaker panel. Powering multiple operators from the same service can result in having to "de-sensitize" the obstruction sensing adjustment to prevent one operator from overloading the other. The electrical hookup is made in the junction box located in the left front corner of the frame, see Figure 7, Page 7. For conduit placement see Figures 5, 6, & 7. The AWG wire size for the electrical service depends on the distance of the operator from the breaker panel. Refer to the table below to determine the correct wire size. The NOMINAL column is the ideal distance from the breaker panel to the operator for a given wire size. The distances shown in the NOMINAL column should never be exceeded. For distances greater than 1600', it is recommended that your local utility be contacted to install a service feeder for the installation.

Wiring from external controls such as guard shack, telephone entry, keypad or card reader systems should be brought to the operator by a conduit separate from the 115 VAC electrical hookup. Low voltage control wires MUST NEVER be routed in the same conduit as A.C. power wires. For conduit placement see Figures 5, 6, & 7. Always consult and follow all local electrical codes.

MAKE SURE POWER IS OFF BEFORE WIRING OR SERVICING THE OPERATOR.

WARNING!

AVOID ELECTROCUTION:
Do not route low voltage wires in the same conduit as high voltage wires. Follow all local electrical codes or the National Electric Code.

WIRE SIZE	NOMINAL DISTANCE
#14	100'
#12	150'
#10	250'
#8	400'
#6	600'
#4	1000'
#2	1600'



WARNING!

RISK OF ENTRAPMENT

Vehicle detector loops will not detect smaller vehicles such as motorcycles, golf carts, bicycles, or pedestrians. Photoelectric detectors, edge detectors and separate pedestrian access must be installed.

Figure 7: Service Conduits

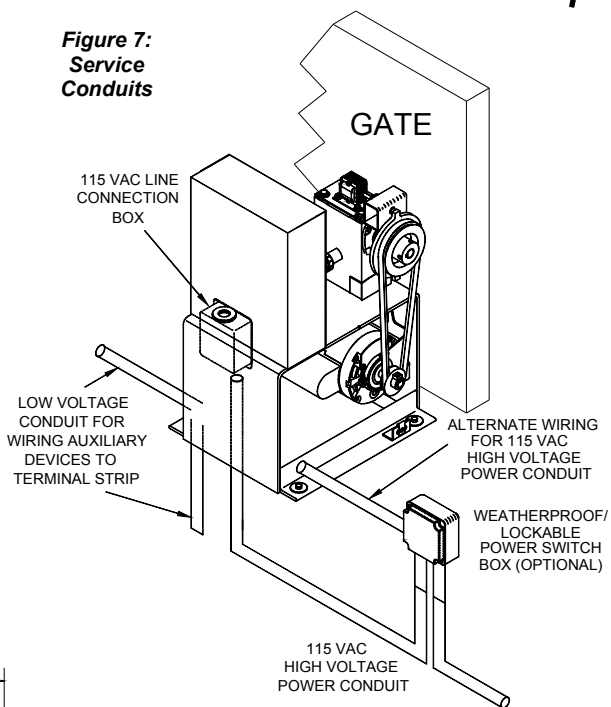
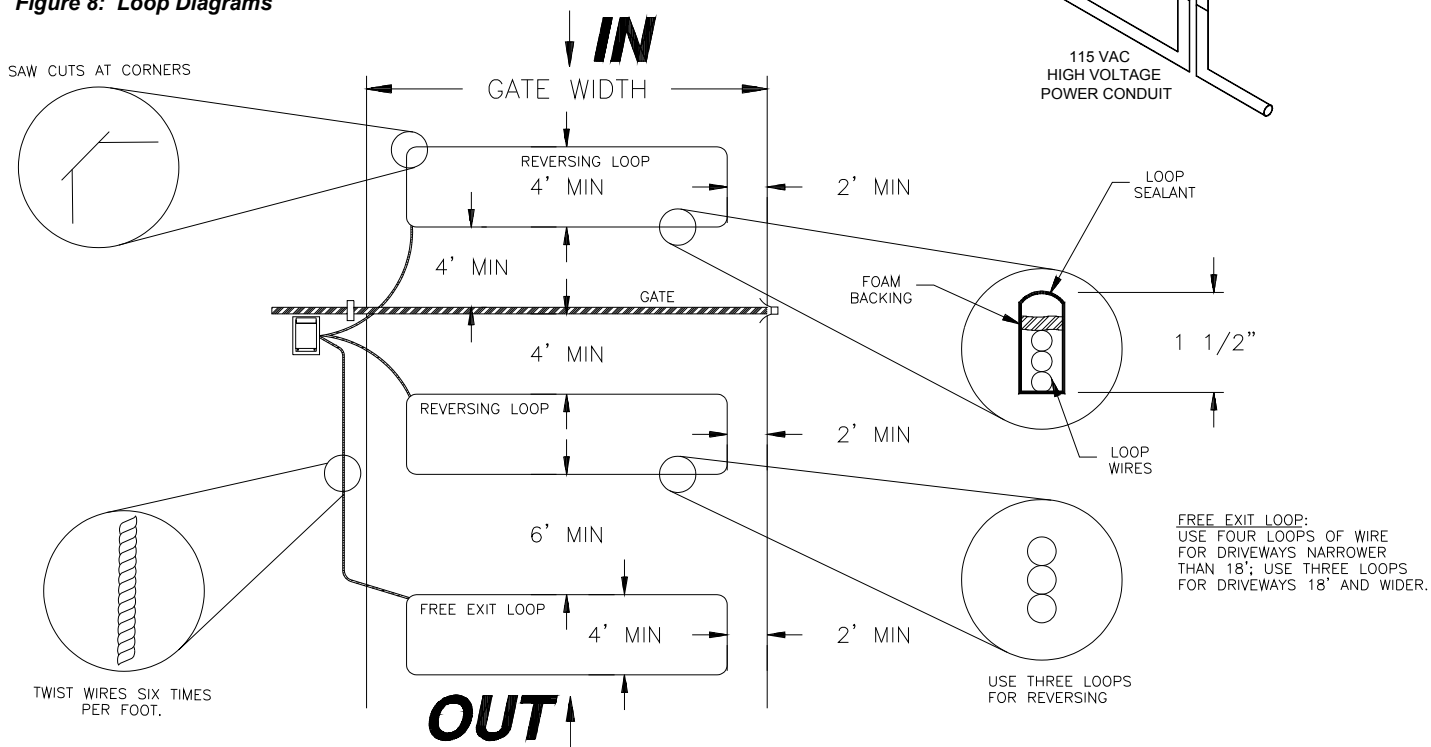


Figure 8: Loop Diagrams



PLACING THE VEHICLE DETECTOR LOOPS

Proper placement of vehicle detector wire loops is critical if the loops are to provide satisfactory, extended service. The most important considerations are: 1) Proper wire type and, 2) Good, tight connections from the loop to the loop terminating connector. When a "Stand Alone" vehicle detector is used, the detection loop is connected to the wire harness on the detector itself. (See WIRING VEHICLE DETECTORS, Page 14.)

The LPX1000 provides for the use of two loop systems: 1) A "reversing" loop that will prevent the gate from closing on a vehicle that has stopped in the path of the gate and, 2) A "free exit" loop that will open the gate by detecting a vehicle which is inside the gated area

and wishes to leave. If "free exit" detection is not desired, this loop will not be needed. Note the "reversing" loop is normally made up of two loops connected to one detector. See Figure 8 above.

Two different types of installations will usually be encountered: 1) If the driveway material is already in place, saw cuts will be needed to accommodate the loop wires.

2) For loops where the paving material will be installed after the loop is positioned, it is necessary that the loop wires be placed in Schedule 40 PVC pipe to maintain uniform loop spacing with respect to the surface of the pavement. The loop should be placed 1.5 inches below the surface of the pavement and at least 2" above any reinforcing steel. The lead-in wires need not be in PVC, but must have at least six (6) twists per running foot.

8 | B: PREPARING THE SITE



For a saw-cut installation, observe the method recommended in Figure 8 for the corners. When installing a two-loop reversing system it is best to bring the twisted lead wires from each loop to the operator so that the loops may be properly phased. The saw cut must be to a depth of 1.5 inches, clean and with no sharp corners. After placing the wires, it is essential that the wires be held tightly in place by the foam backing and that no voids exist that can collect water which might freeze and push the loop wires out of the slot. The sealant used should match the paving material and should not be hard setting. The lead-in wires must have at least six (6) twists per foot.

NO SPLICES ARE ALLOWED IN THE LOOP OR THE LEAD-IN WIRE TO THE FIRST JUNCTION BOX. Above ground splices may be used providing the wire is twisted, soldered and moisture sealed. For best long term results, do not use wire nuts anywhere in the loop system. For connections to the loop detector, gas tight crimp type terminals should be used, and soldered if possible.

THE WIRE USED FOR THE LOOPS MUST BE HEAT AND WATER RESISTANT. CROSS-LINK POLYETHYLENE INSULATED, TYPE XLPE OR RHW IS BEST. U.S.E. IS ALSO SATISFACTORY. DO NOT USE PVC INSULATED WIRE. WIRE SIZE SHOULD BE #16 GA STRANDED OR LARGER.

C: INSTALLING THE OPERATOR



TOOLS REQUIRED

The following tools and materials are required for proper installation of the operator:

1. Two 3/4" wrenches. (For tightening hex nuts on the chain take-up bolts.)
2. Chain cutting tool. (For adjusting chain length.)
3. Wire cutter, stripper and crimping tools. (For attaching accessory equipment to the control box barrier strip.)
4. Standard screwdriver. (For junction box face plate.)
5. Very small standard screw driver. (For adjusting controller board trimmer potentiometers.)
6. Phillips head screwdriver. (For control box face plate.)
7. Electric arc welder or an electric drill with a 3/8" bit. (For attaching chain brackets to gate.)
8. Several feet of 18 AWG or 22 AWG insulated multi-strand electrical wire. (For attaching accessory equipment to the control box barrier strip.)
9. Four 1/2" anchor bolts with hex nuts, flat washers and lock washers. (For attaching the operator to the concrete pad.) Additional flat washers may be required as leveling shims (see Page 9).
10. 1/2", 9/16" & 5/8" wrenches for various fasteners.

UNPACKING CHECKLIST

The following is a check list of the various parts included with the LPX1000 operator:

1. (1) LPX1000 Slide Gate Operator w/Cover
2. (2) Gate Warning Signs
3. (1) Installation Manual
4. (2) End Chain Brackets
5. (1) Chain Take-up Bolt Kit
6. (25 ft) #41 Chain
7. (2) Master Links



ATTACHING THE CHAIN BRACKETS and PLACING THE LPX1000 OPERATOR

The chain brackets provided with the LPX1000 operator are mounted on each end of the gate with the centerline of the slot 8" above the top of the operator pad. You will normally require a welder, or an electric drill with a 3/8" bit, for attaching the chain brackets to the gate. See Figures 9 and 10.

From the center of the slot in the bracket, run a string line taugth from one chain mounting bracket to the other. Place the operator on the new pad or existing concrete base and position the unit so that the string is centered on the primary drive sprocket, centered on the pad from left to right, and parallel with the gate frame as shown in Figure 10a. Using the operator as a template, mark and drill the appropriate holes for the required anchor bolts (four [4] 1/2" anchor bolts are required). Install the anchor bolts per the bolt manufacturers instructions.

Re-sit the operator over the anchor bolts, making sure the operator is sitting level. If any corners of the operator are resting

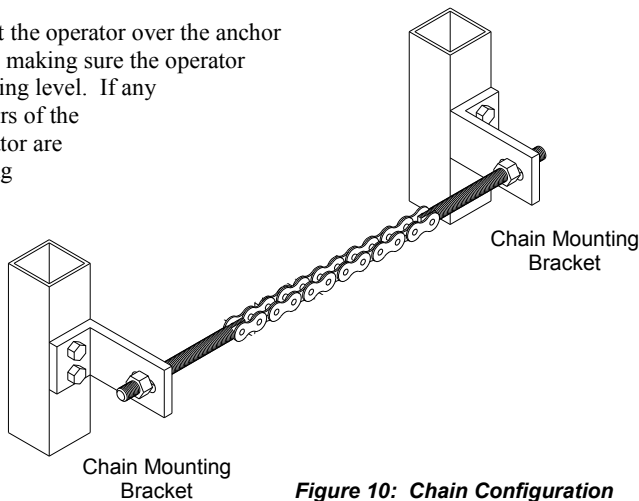


Figure 10: Chain Configuration

above the pad, place flat washers as shims between the operator and concrete pad (around the anchor bolts). Place the flat washers, lock washers and nuts on the anchor bolts and tighten down the operator securely.

Attach one end of the chain to the gate and thread the other end through the idler pulleys and drive sprocket. Attach the free end to the bracket on the opposite end of the gate and tension the chain. See Figures 9 and 10.

Do not over-tension the chain.

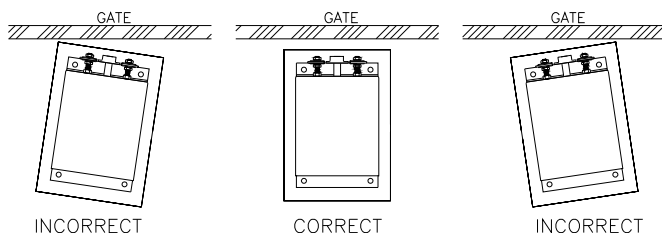


Figure 10a: Parallel Placement

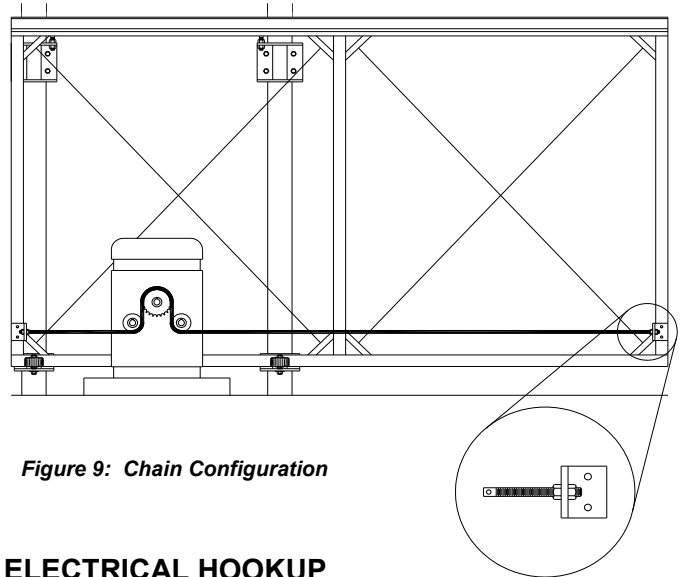


Figure 9: Chain Configuration

ELECTRICAL HOOKUP

The operator requires a 3-wire, 115 VAC electrical hook-up for proper operation. Ideally, the conduit containing the hook-up wires should exit the concrete pad under the operator. There is a 3" gap in the front of the bottom plate of the operator provided for this purpose. Run flexible conduit from the point where the conduit exits the pad and attach it to the bottom of the right junction box at the front of the frame. Review Figure 5, Page 6. If the hook-up exits the pad external to the operator, there's a 7/8" diameter hole in each side of the frame near the front of the operator. Connect the conduit to either hole and cut a small slot in the 1-1/2" high skirt around the base of the cover. This will allow the cover to fit down flush with the conduit in place. Review Figure 7, Page 7. Remove the right junction box face plate. Using the wire nuts, attach the three lead wires to the electrical hook-up wires in the following manner:

1. The BLACK wire attaches to the 115 VAC HOT wire.
2. The WHITE wire to the 115 VAC NEUTRAL wire.
3. The GREEN wire to the GROUND wire.

NOTE: The LPX1000 control board comes equipped with a built-in surge protection which MAY prevent damage to the controller board in the event of a nearby lightning strike or a surge in the power lines. For the surge protector to function, and as a general precaution, the operator must be properly grounded. The third wire for the ground must be installed.

ADDITIONAL LIGHTNING PROTECTION

For those areas where a high probability of ground lightning strikes exists (Florida, Georgia, etc.), additional lightning protection should be installed in the LPX1000. Although it may not be possible to protect against all strikes, additional protection will substantially reduce the occurrence of lightning damage. Industry lightning data indicates that the most strikes enter an appliance through the power lines. Effective protection requires that the surge current from the lightning strike be



WARNING!

RISK OF ELECTROCUTION

Do not begin the electrical connection procedures until the power is turned off at the circuit breaker.

10 | C: INSTALLING THE OPERATOR



shunted to ground. This must be done without raising the potential of the circuitry in the LPX1000, with respect to ground, to the levels that will damage the solid state circuitry. Lightning strikes generate enormous currents for very short periods of time. Unfortunately, the period of time is long enough to damage solid state components and many times, other components. The key to success is a very low resistance path from the surge protector to ground for these currents in addition to a surge protector that will act fast enough to protect the solid state circuitry. Several manufacturers offer suitable surge protectors.

⚡ WARNING!

TO REDUCE THE RISK OF DAMAGE DUE TO LIGHTNING, ENSURE A SOLID GROUND FROM THE LPX1000 GROUND WIRE IN THE SERVICE ENTRANCE 4 x 4 HANDY BOX TO THE ELECTRICAL SERVICE GROUND OR TO A EARTH GROUND STAKE NEAR THE LPX1000.

CONTROL AND ACCESSORY EQUIPMENT WIRING

IMPORTANT - remove power from the operator before attempting to connect an accessory device or control station.

All accessory equipment is hooked-up to the 22 terminal barrier strip located on the back of the control box. See Figure 11. There are no installer connections inside the control box. **NO ACCESSORY EQUIPMENT SHOULD BE INSTALLED IN THE CONTROL BOX!**

If local electrical codes permit, use the operator's bottom plate for mounting accessory components. Otherwise, install the accessory equipment in an appropriate electrical box.

The thirteen (13) command inputs for the LPX1000 require a switch closure to COMMON of less than 100 OHMS resistance and for more than 100 milliseconds duration. Two of the inputs - ALTERNATE and RADIO OPEN - are momentary inputs where the signal must be released and re-entered to be recognized. The remaining inputs can be continuous signals. A label on the left side of the control box lists the function of each of the terminals on the barrier strip, see Figure 11. Also see the Reference Chart on Page 20 and 21.

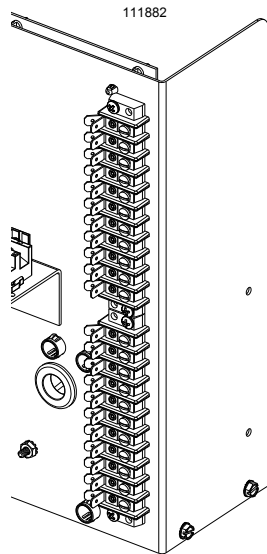


Figure 11: 22 Position Terminal Strip

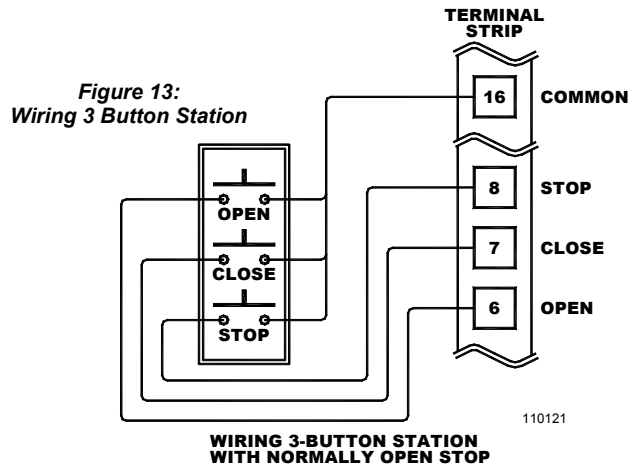
WIRING A 3-BUTTON STATION

See Figure 13 for instructions on wiring a 3-button station.

NOTE: The STOP button is normally OPEN

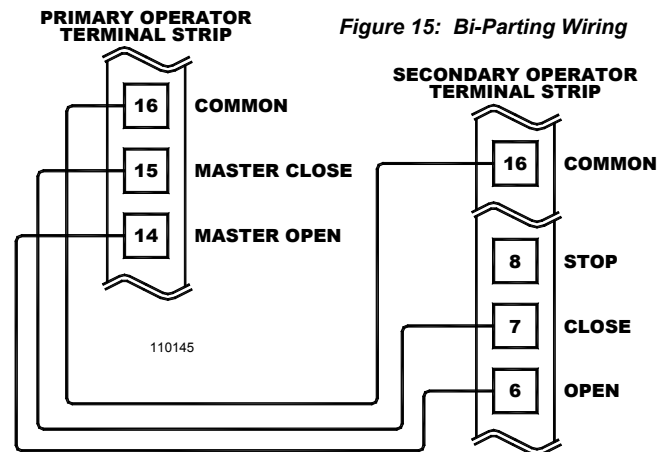
BI-PARTING APPLICATION

In a bi-parting application, two operators are required, one operating in a left-hand mode, the other in a right-hand mode (see page 15) to control two gate sections that make up a single gate. Both must be wired individually for AC power (as previously described) but share a common set of input controls. In general, all of the instructions concerning installation of individual operators can be followed in a bi-



parting application except the following:

Choose one of the operators to be the PRIMARY and the other to be the SECONDARY. Route all of the control wiring to the PRIMARY operator first. This will prevent grounding loop problems which can occur when more than one COMMON or ground wire is attached between separate operators. All accessory equipment should also be wired to the PRIMARY.



Connect terminal #14 (MASTER OPEN) on the PRIMARY operator to terminal #6 (OPEN) on the SECONDARY operator. Connect terminal #15 (MASTER CLOSE) on the PRIMARY operator to terminal #7 (CLOSE) on the SECONDARY operator. Connect terminal #16 (COMMON) on the PRIMARY operator to terminal #16 (COMMON) on the SECONDARY operator. Dual 1/4" disconnect terminals for each input are provided for this purpose. Use conduit SEPARATE from AC power service. See Figure 15 for the correct wiring.

Switch #3 of the Switch Selectable Options must be set to the proper position, see page 17.

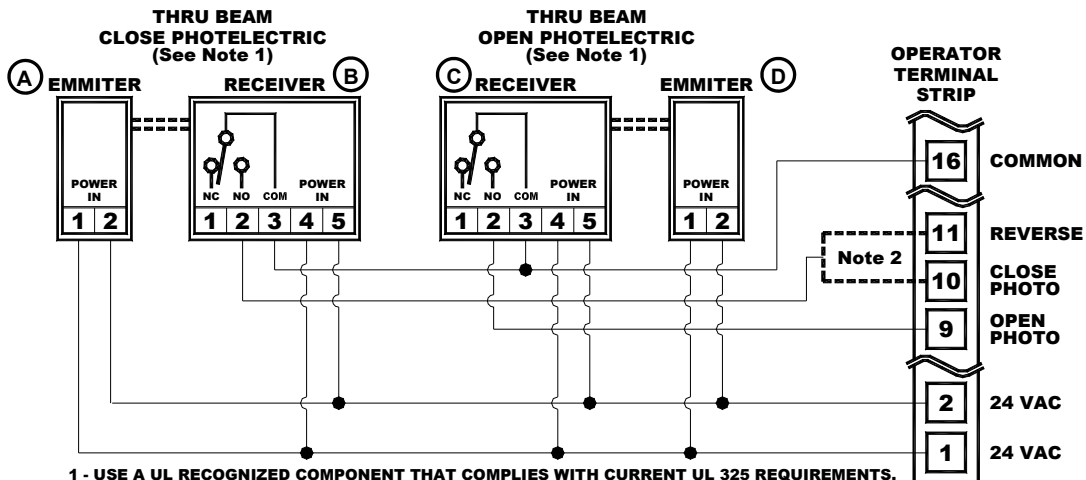
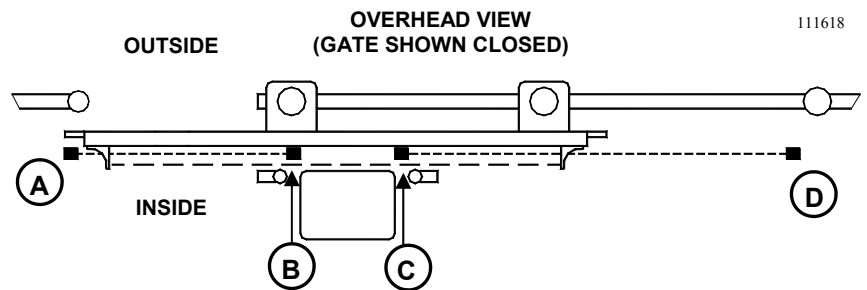
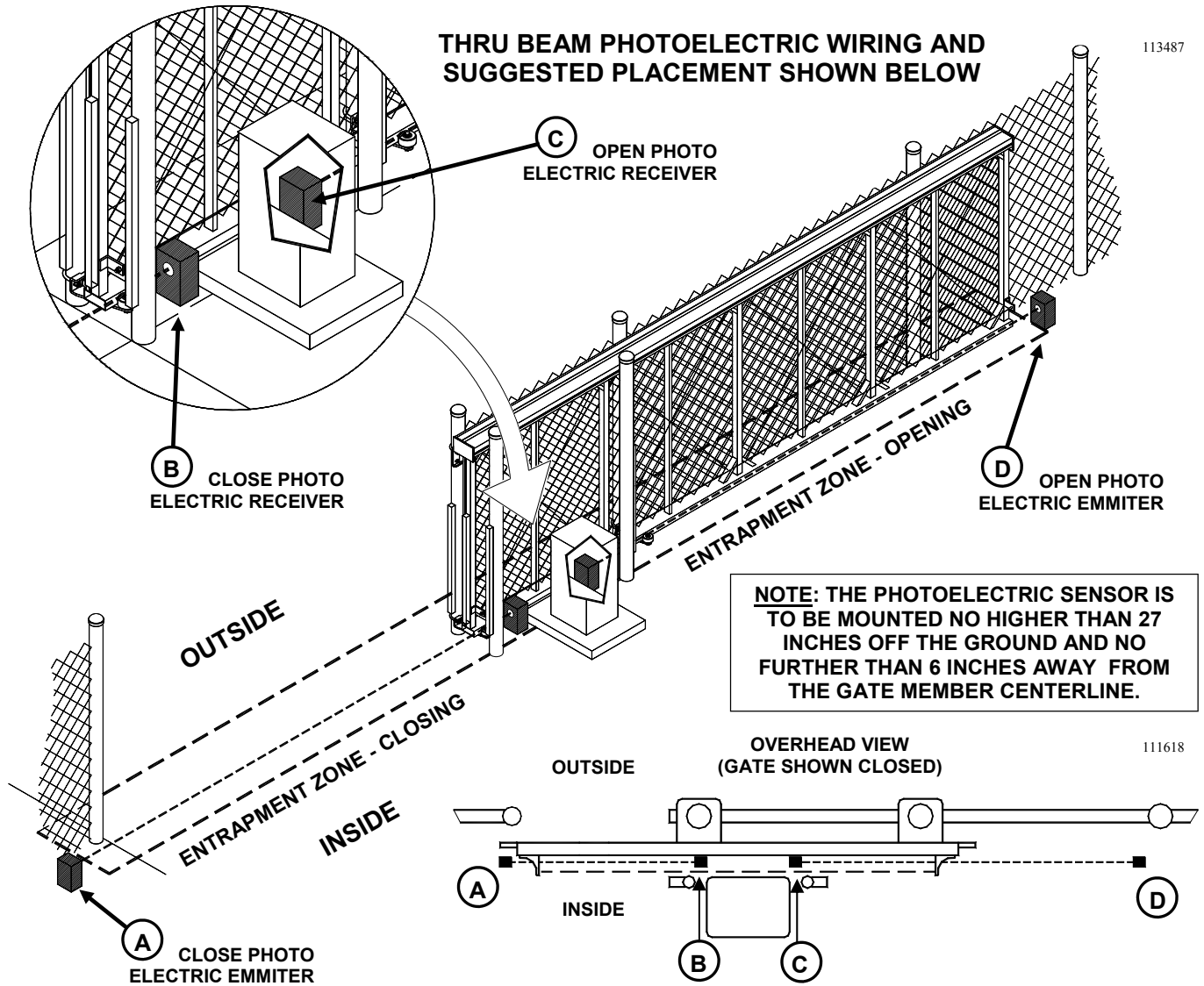
NOTICE: A separate 3-wire (HOT, NEUTRAL and GROUND), 115 VAC electrical connection is required for each operator in a bi-parting installation

⚡ WARNING!

IMPROPER WIRING COULD CAUSE ELECTROCUTION OR DAMAGE TO CIRCUITRY. FOLLOW LOCAL BUILDING AND ELECTRICAL CODES.



WIRING AND SUGGESTED PLACEMENT OF OPTIONAL NON-CONTACT SENSOR (PHOTOELECTRIC) SECONDARY ENTRAPMENT PROTECTION DEVICES

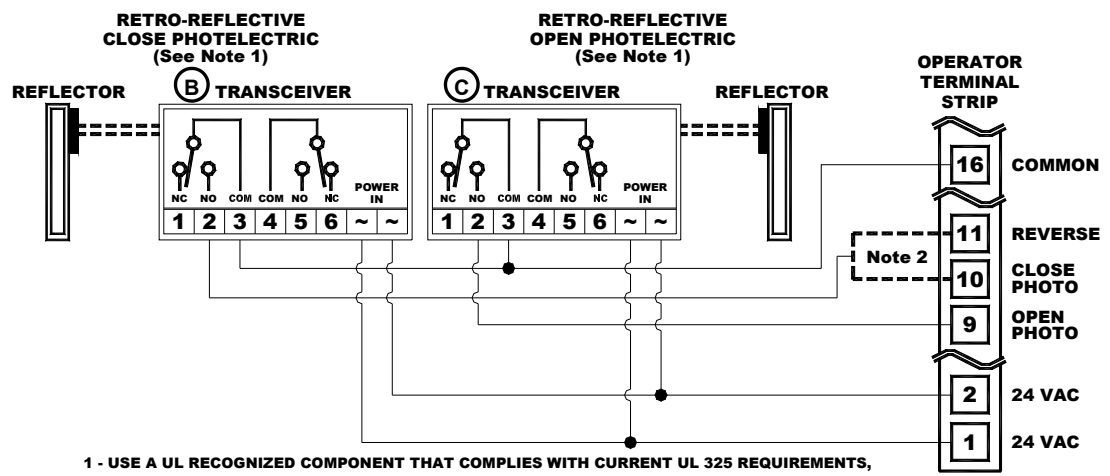
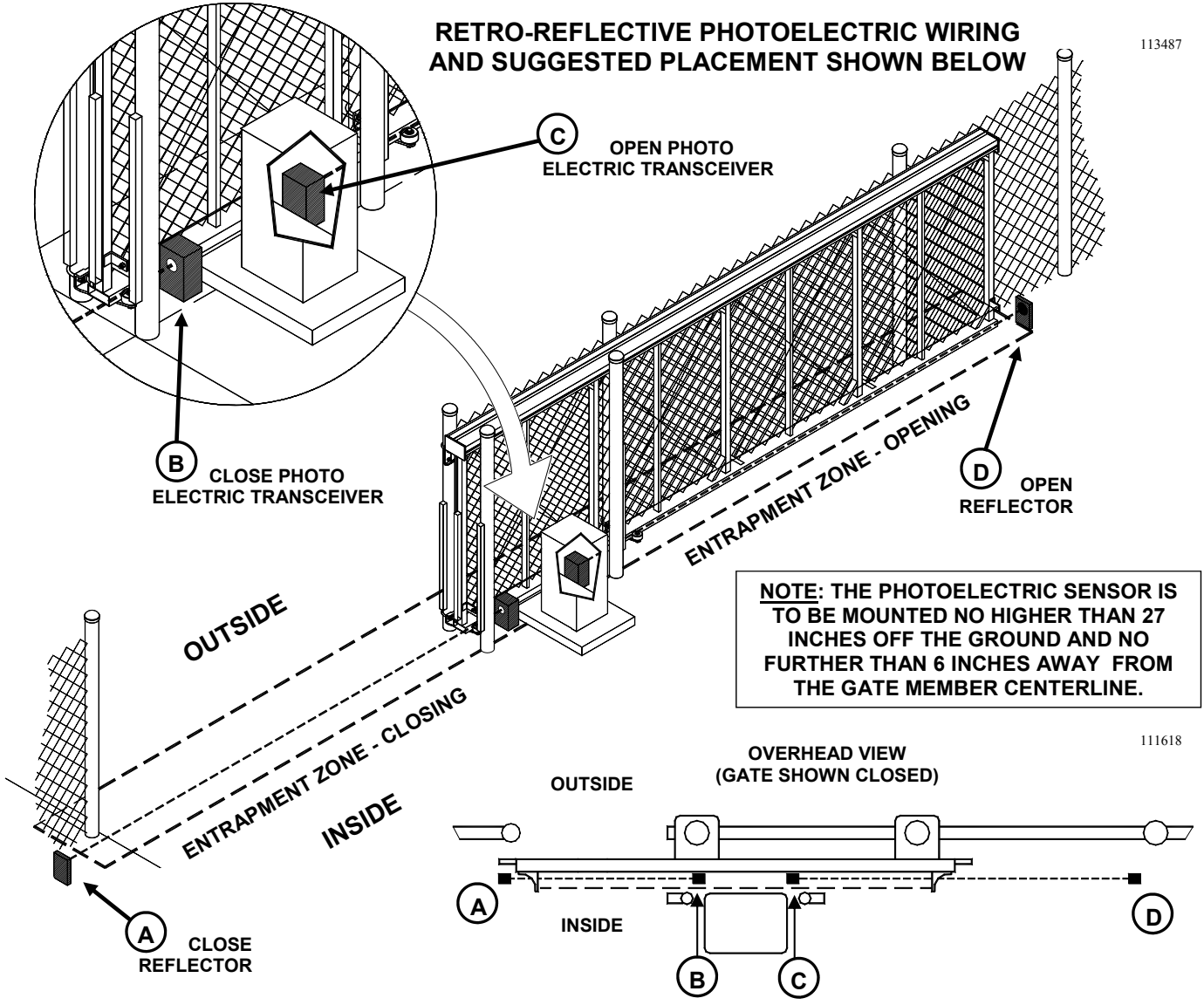


- 1 - USE A UL RECOGNIZED COMPONENT THAT COMPLIES WITH CURRENT UL 325 REQUIREMENTS, TERMINAL NUMBERS ABOVE REPRESENT MODEL IR55, WIRING FOR OTHERS SIMILAR
- 2 - SELECT TERMINAL BASED ON FUNCTION DESIRED, SEE TERMINAL STRIP REFERENCE CHART

12 | C: INSTALLING THE OPERATOR



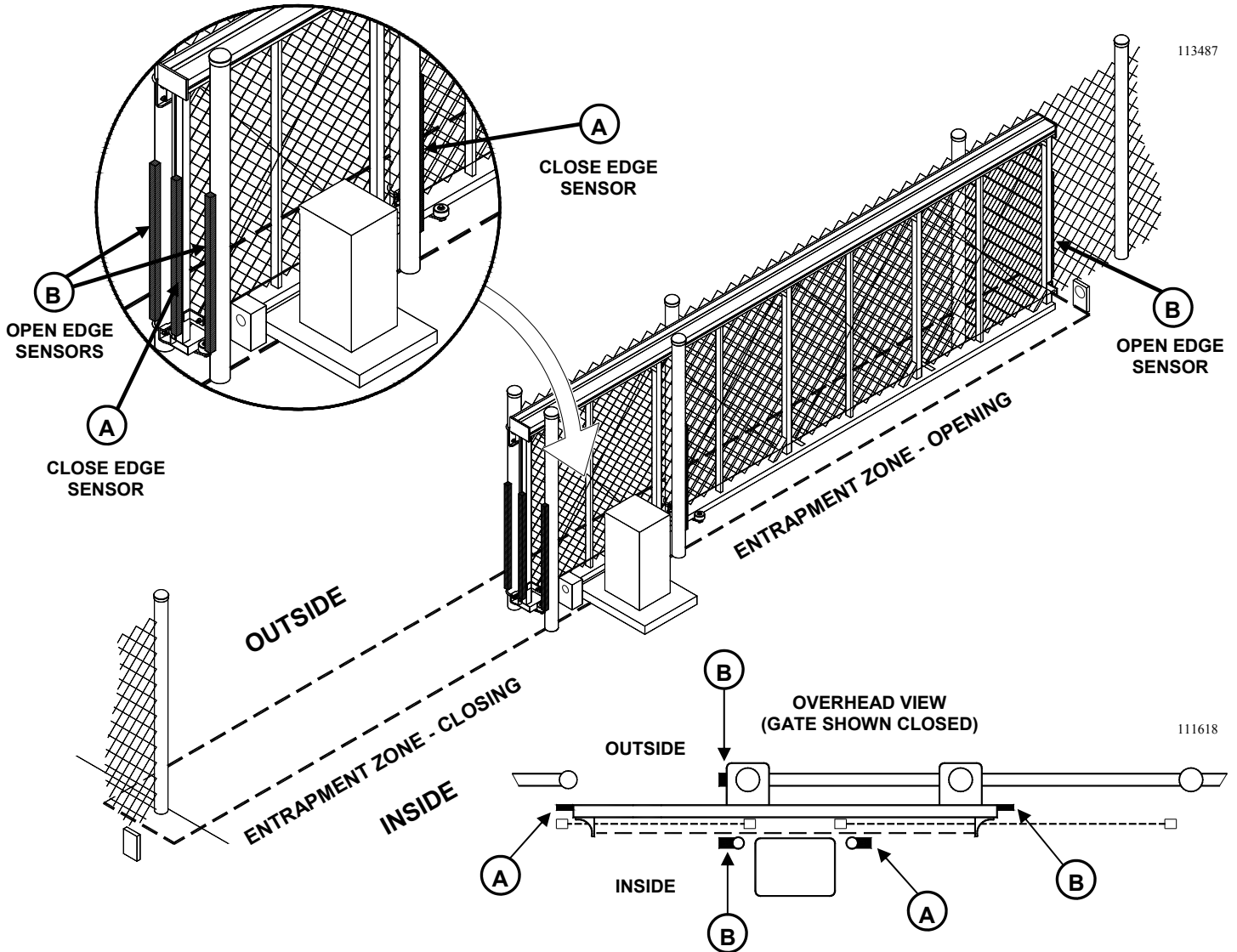
WIRING AND SUGGESTED PLACEMENT OF OPTIONAL NON-CONTACT SENSOR (PHOTOELECTRIC) SECONDARY ENTRAPMENT PROTECTION DEVICES



- 1 - USE A UL RECOGNIZED COMPONENT THAT COMPLIES WITH CURRENT UL 325 REQUIREMENTS, TERMINAL NUMBERS ABOVE REPRESENT MODEL E3K, WIRING FOR OTHERS SIMILAR
- 2 - SELECT TERMINAL BASED ON FUNCTION DESIRED, SEE TERMINAL STRIP REFERENCE CHART



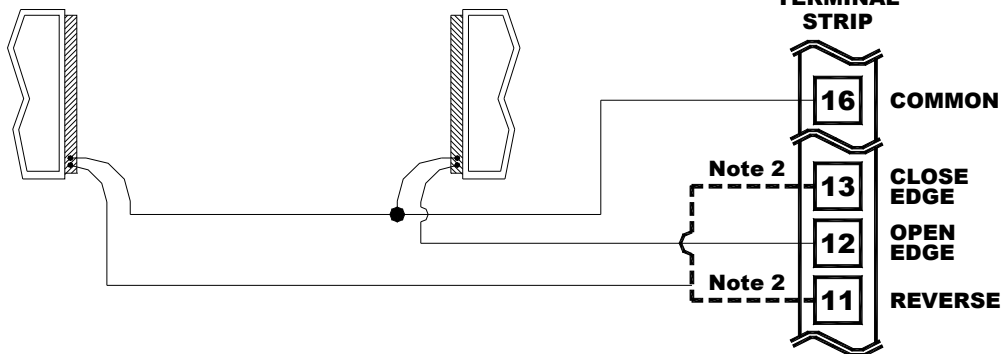
WIRING AND SUGGESTED PLACEMENT OF OPTIONAL CONTACT SENSOR (ELECTRIC EDGE) SECONDARY ENTRAPMENT PROTECTION DEVICES



(A) CLOSE EDGE SENSOR(S)
(SEE NOTES 1 & 3)

(B) OPEN EDGE SENSOR(S)
(SEE NOTES 1 & 3)

OPERATOR TERMINAL STRIP



113487

111618

113411

1 - USE A UL RECOGNIZED COMPONENT THAT COMPLIES WITH CURRENT UL 325 REQUIREMENTS, AN EDGE SENSOR THAT ACTIVATES ON THREE (3) SIDES SHOULD BE USED

2 - SELECT TERMINAL BASED ON FUNCTION DESIRED, SEE TERMINAL STRIP REFERENCE CHART

3 - MULTIPLE EDGE SENSORS MAY BE CONNECTED IN PARALLEL

14 | C: INSTALLING THE OPERATOR



INSTALLING AND WIRING VEHICLE DETECTORS

REVERSING LOOP VEHICLE DETECTOR: If a Reversing Loop Vehicle Detector is to be a part of this installation, start with this first. Install a 24 VAC powered, 11 pin (round configuration) vehicle detector module into the detector socket. The vehicle detector module must have a relay contact output. The Reversing Loop socket is pre-installed in the rear of the control panel and is the socket closest to the operator side wall. The actual loop is installed in the concrete or asphalt surface in accordance with the manufacturer's instructions and the information outlined earlier in this manual (see Page 7). Connect the wires from the actual Reversing loop to Terminals C and D, see Figure 13. If employing two (2) Reversing Loops as shown in the diagram on Page 7, and are connecting the loops to the same Loop Detector, wire in series as shown in Figure 13A.

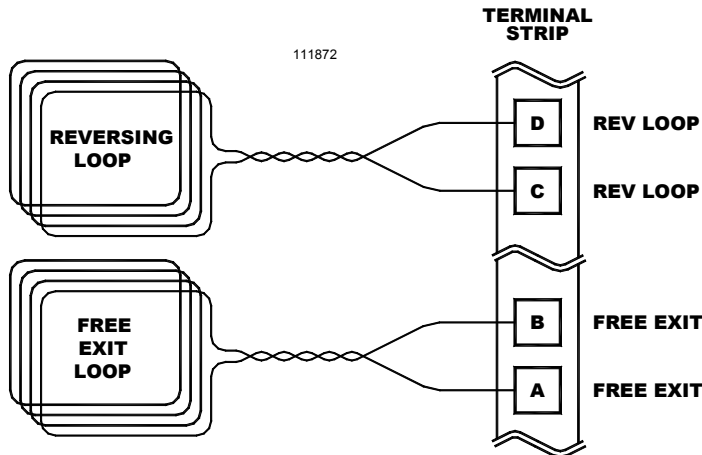


Figure 13: Wiring A Free Exit or Reversing Loop Detector

FREE EXIT VEHICLE DETECTOR: If also employing a Free Exit Loop Vehicle Detector, install a 24 VAC powered, 11 pin (round configuration) vehicle detector module into the detector socket. The vehicle detector module must have a relay contact output. The Free Exit Loop socket is pre-installed in the rear of the control panel and is the socket towards the middle. The actual loop is installed in the concrete or asphalt surface in accordance with the manufacturer's instructions and the information outlined earlier in this manual (see Page 7). Connect the wires from the actual Free Exit loop to Terminals A and B, see Figure 13.

Set the frequency and sensitivity switches (if any) according to the loop detector manufacturer's instructions.

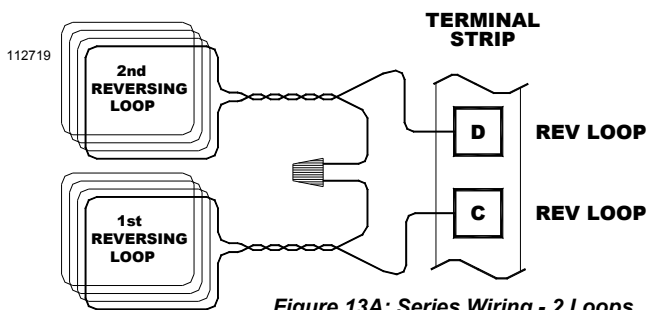


Figure 13A: Series Wiring - 2 Loops

WIRING A RADIO RECEIVER

Radio receivers must be of the 4-wire connection hook-up type (where the power input for the receiver is separate from the receiver's output connection). This is necessary as the LPX1000 control board 24 VAC is isolated from chassis ground. A 3-prong receiver CANNOT be

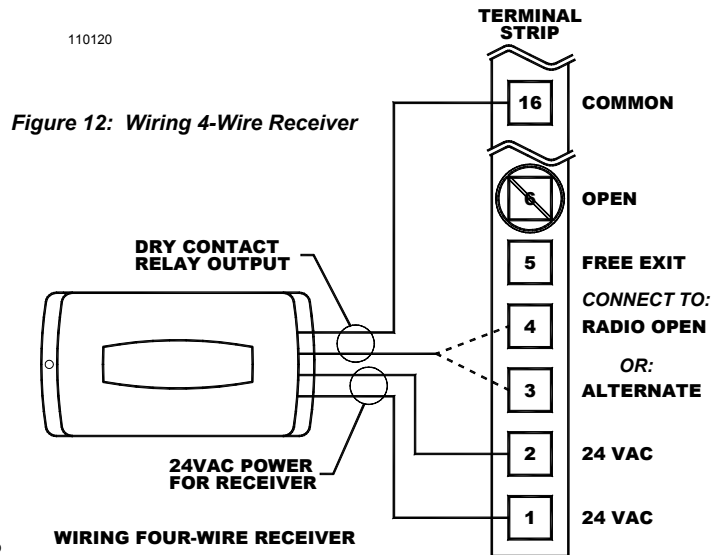


Figure 12: Wiring 4-Wire Receiver

installed in association with the LPX1000 control board.

Connect the receiver's two wires for power to terminals #1 and 2 (24 VAC). The radio receiver installation is now complete. Connect one of the two wires for the relay to terminal #4 (RADIO OPEN) or terminal #3 (ALTERNATE) depending on the function desired (see descriptions on the chart on page 17 and 18) and the other wire to terminal #16 (COMMON) on the LPX1000 terminal strip. See Figure 12 for connecting a four wire radio receiver.

WARNING!

RISK OF ENTRAPMENT!

TO REDUCE THE RISK OF INJURY OR DEATH: LOCATE KEYPAD, CARD READER, KEY SWITCH OR SIMILAR ENTRY DEVICES IN A LOCATION WHERE A USER CAN NOT REACH THROUGH THE GATE OR FENCE TO ACTIVATE THE GATE OPERATOR. THE RECOMMENDED DISTANCE BETWEEN THE GATE OR FENCE AND ACCESSORY SWITCH IS 10 FEET.

WIRING A KEYPAD / TELEPHONE ENTRY SYSTEM

Install according to the manufacturer's instructions. Follow Figure 14 for connections to the LPX1000 22 position terminal strip.

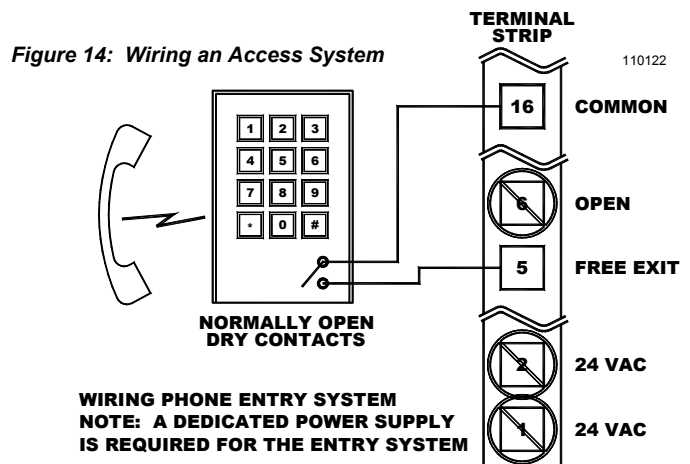


Figure 14: Wiring an Access System

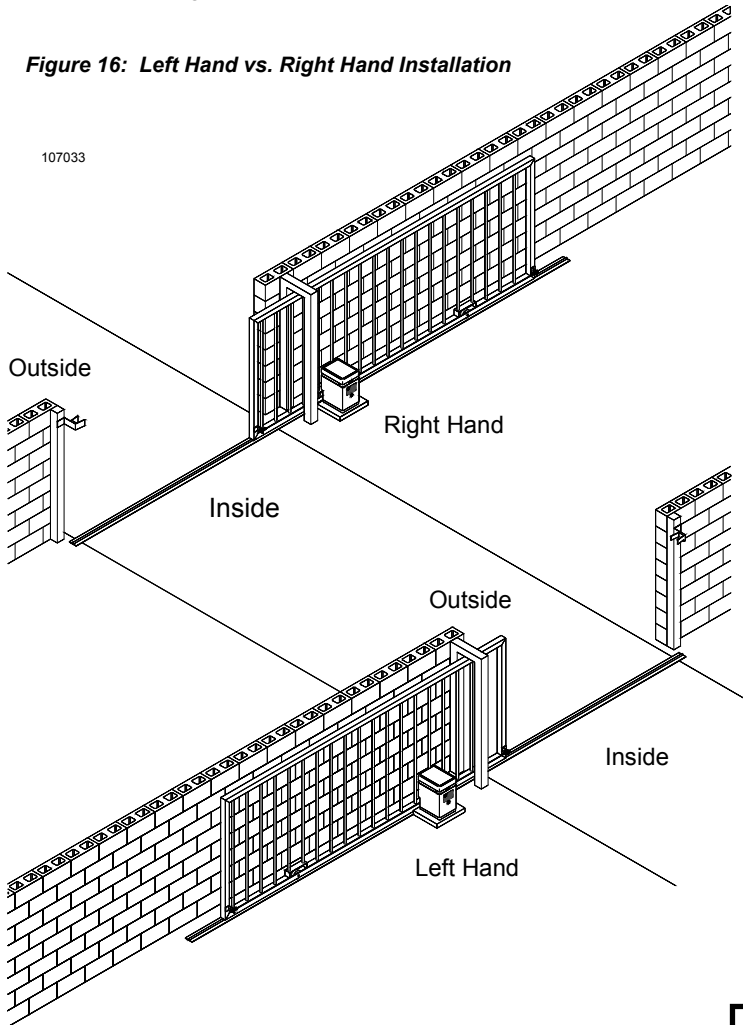
WIRING PHONE ENTRY SYSTEM
NOTE: A DEDICATED POWER SUPPLY IS REQUIRED FOR THE ENTRY SYSTEM



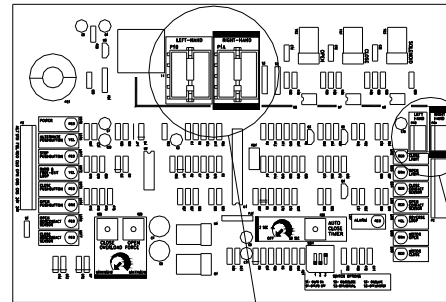
LEFT- OR RIGHT-HAND INSTALLATIONS

The LPX1000 operator can be configured for left- or right-hand gate installations. See Figure 16. On a normal drive installation, when standing inside the gate and facing outwards, if the operator is on the right side of the gate, it's a right-hand installation. If the operator is on the left side of the gate, it's a left-hand installation.

Figure 16: Left Hand vs. Right Hand Installation



Locate the 3 position limit switch wire harness connector midway down the right side of the controller board. Switch it to the position labeled, "LEFT-HAND". The operator is now configured for a left-hand installation.



LOCATION OF RIGHT-HAND & LEFT HAND HARNESS CONNECTIONS

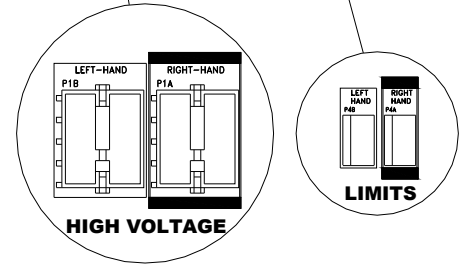


Figure 17: Control Board Settings for LH/RH Operation

The operator is shipped from the factory configured for right-hand installations. If it is installed in a left-hand installation, make sure the main power switch is off and locate the 8-pin, motor wire connector in the upper center of the controller board. See Figure 17.

Pinch the locking tabs on the two sides of the connector and remove it from the connector labeled, "RIGHT-HAND". Then plug it into the connector labeled, "LEFT-HAND".

! WARNING!

THE MOTOR WIRE CONNECTOR AND THE LIMIT HARNESS CONNECTOR MUST BOTH ALWAYS BE IN EITHER THE RIGHT OR LEFT POSITIONS. IF ONE IS IN THE RIGHT POSITION AND THE OTHER IN THE LEFT POSITION, THE OPERATOR WILL NOT STOP THE GATE WHEN IT REACHES THE END OF TRAVEL.

16 | C: INSTALLING THE OPERATOR



SETTING THE LIMIT SWITCHES

Before turning on the main power, set the limit switches which are located on top of the frame, between the control box and the reducer gearbox. See Figure 18. In a right-hand installation, the switch nearest the control box is the open limit switch. In a left-hand installation, the switch closest to the gearbox is the open limit switch.

Manually push the gate all the way open. Press down on the spring loaded detent plate and rotate the open limit nut toward the open limit switch contactor until you hear the open limit switch click. Rotate the limit nut two more slots to give the operator time to stop the gate after the limit switch has been activated. Release the detent plate and make sure it drops into the slots on both limit nuts.

Manually push the gate all the way closed. Depress the detent plate and rotate the close limit nut clockwise until the close limit switch clicks. Again rotate the close limit nut two more slots. Release the detent plate and make sure both limit nuts are firmly seated.

The limit switches are now roughly adjusted. If the gate should stop short of fully opened or closed, or if it bangs against the end stops during operation, the limit switches can be fine-tuned after the operator is powered up. (See FINAL SETTING OF THE LIMIT SWITCHES, P. 19.)

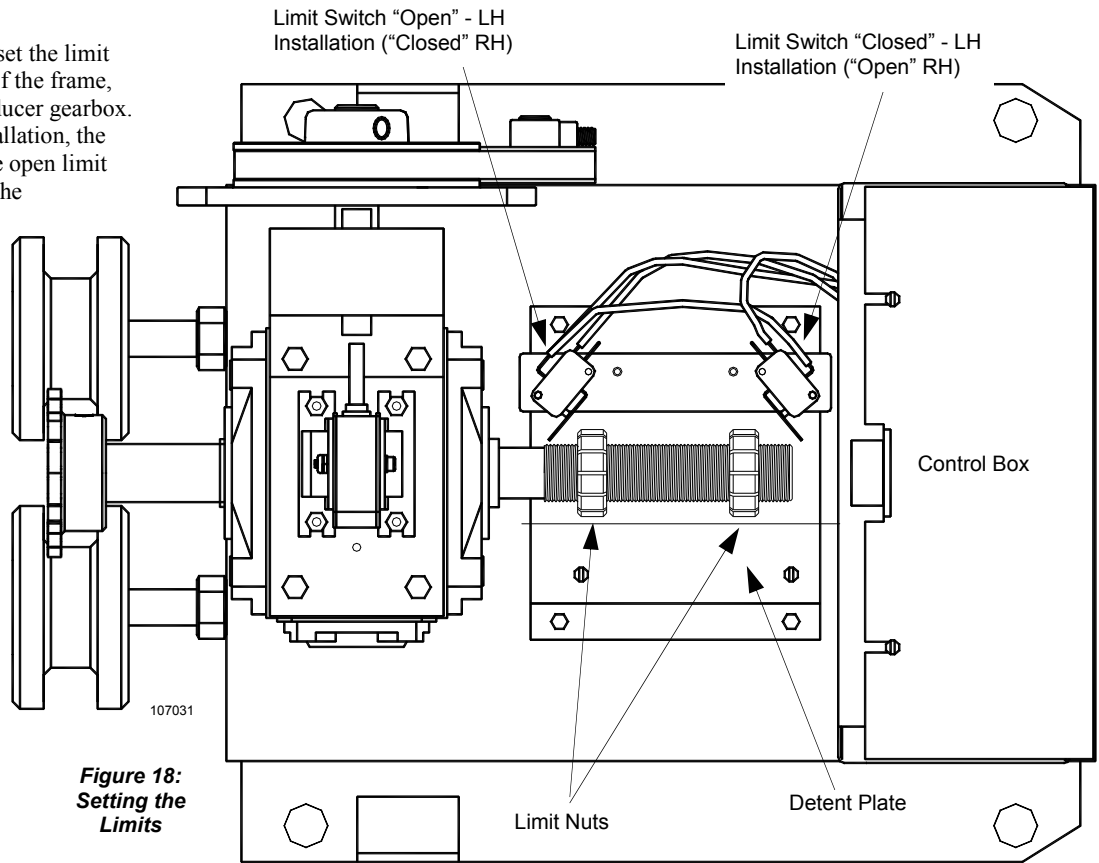


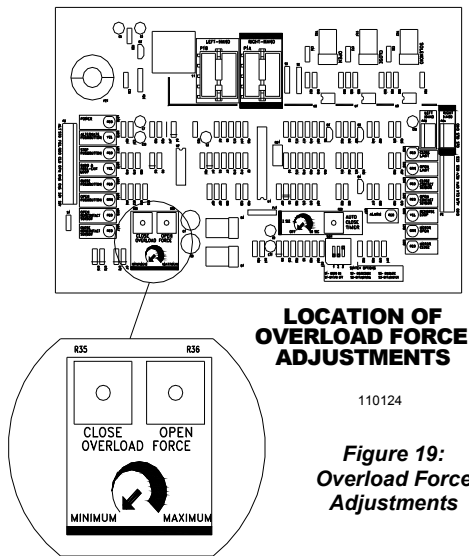
Figure 18:
Setting the Limits

SETTING THE OBSTRUCTION DETECTION OVERLOAD FORCE

The operator is equipped with an obstruction detection circuit which will detect MOST obstructions in the gate's path. See Figure 19. The overload force can be independently adjusted for OPEN and CLOSE with the potentiometers on the controller board labeled, "OVERLOAD FORCE". Turning a potentiometer clockwise increases the force to activate and turning it counterclockwise decreases the force required.

The LPX1000 is shipped from the factory with the potentiometers set at the minimum force setting. Turn the potentiometer 1/4 turn clockwise to prevent the overload circuit from tripping due to the gate's inherent friction.

See FINAL SETTING OF THE OBSTRUCTION DETECTION OVERLOAD FORCE setting on Page 19.



LOCATION OF OVERLOAD FORCE ADJUSTMENTS

110124

Figure 19:
Overload Force Adjustments

⚠ WARNING!

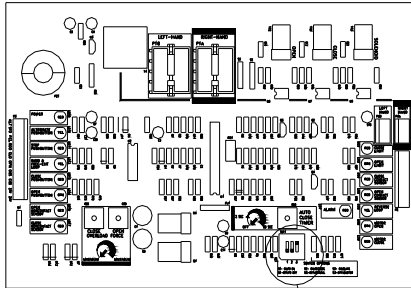
RISK OF ENTRAPMENT.

THE OVERLOAD POTENTIOMETER MUST BE SET MORE PRECISELY PRIOR TO COMPLETING THE OPERATOR INSTALLATION

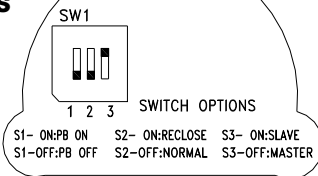


Figure 20: Switch Selectable Options

110126



LOCATION OF SWITCH SELECTABLE OPTIONS



SETTING THE SWITCH SELECTABLE OPTIONS

There are three (3) option selection switches on the LPX1000 controller board that result in four (4) switch selectable options. Please review Figure 20. The switches are contained in a 3-pole dip switch package at the bottom right of the board. The text that follows describes each of the options they select

NO-LOAD TEST MODE

To run/test the LPX1000 operator when it is not connected to a gate leaf, turn all of the switches to the “ON” position. The LPX1000 can then be operated without a gate leaf attached for 20 complete cycles. If more than twenty cycles are attempted in the test mode the operator control board changes to a “sleep” mode and a low pulsed tone is heard from the audible output. You can reset the operator for a renewed 20 test cycles by turning the power off and back on again. To return to normal operation turn one of the switches to the “OFF” position, then set all the switches to the desired mode of operation as described in the text that follows.


Safe Secure™ OPEN/CLOSE PUSH BUTTON ENABLE/DISABLE (PATENT NO. 6,611,205)

Switch S1 controls the Push Button Enable/Disable Feature.

SWITCH 1 OFF: Activating the Open or Close buttons the gate will open or close fully. Activation of the Open while the gate is closing will cause it to re-open. Activation of the Close while the gate is opening has no effect. Continuous activation of an opposing button while the gate is on a limit will prevent operation in that direction. Continuous signal required to move the gate when in the alarm mode.
SWITCH 1 ON: Gate does not respond to pushbutton input when in the normal mode. Continuous signal required to move the gate when in the alarm mode. This patent pending feature allows you to mount a three button station in an unsecured location as the OPEN and CLOSE buttons will only be active when in the alarm mode. STOP is always active.

TIMER TO CLOSE SETTING

The Timer to Close is controlled by the setting of the “AUTO CLOSE TIMER” potentiometer on the control board, see Figure 21. When the pot is adjusted fully counter-clockwise the Timer-To-Close is disabled. Turning the pot approximately 1/4 turn clockwise will enable the Timer To Close function with a delay of approximately 2 seconds between the gate reaching the full open position and automatically closing. To increase the time delay continue to turn the pot in the clockwise direction to a maximum delay of 60 seconds (one minute).



WARNING!

RISK OF ELECTROCUTION
DO NOT BEGIN TO SET OR RESET THE FOLLOWING ADJUSTMENTS UNTIL THE POWER IS TURNED OFF AT THE LPX1000 CONTROL BOX

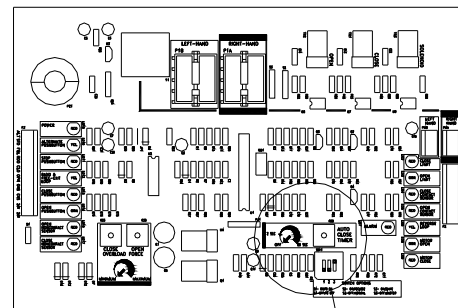
AUTO RE-CLOSE (TIMER-TO-CLOSE FUNCTION)

Switch S2 controls the Auto-Re-close function. If the Timer To Close function is enabled (see above), setting Switch S2 to the ON position will activate the Auto-Re-close feature on the motor control board. When the auto-re-close is activated, the gate will re-close after stopping and backing-off from a non-contact sensor input if the close movement was initiated by the Timer-To-Close function on the control board. The gate will not re-close if the sensor input was received from a contact sensor or if the inherent overload sensor was activated. In the Test Mode or the Slave (Secondary) Mode the Timer-To-Close is automatically disabled.

BI-PARTING (MASTER/SLAVE) CONFIGURATION

Switch S3 controls the Bi-Parting Master/Slave (Primary/Secondary) terminals (#14 & 15) configuration setting. The setting is changed when two operators are used in conjunction with each other to control two separate gate sections that make up a single gate.

With Switch S3 in the ON position terminals # 6 & 7 (OPEN and CLOSE inputs) are in the Slave (Secondary) mode and could be coupled to and would be controlled by a Master (Primary) operator. In the Slave (Secondary) mode the Switch S1 and S2 must be OFF.



110125

LOCATION OF AUTOCLOSE TIMER ADJUSTMENT

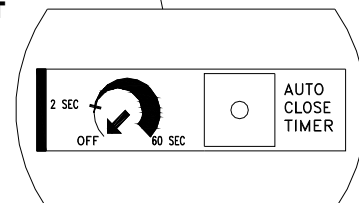


Figure 21: Location of Auto-Close Timer Adjustment



FINAL INSTALLATION CHECKLIST

1. Use a voltmeter to assure the service voltage to the operator is 115 VAC. Connection to 220 VAC service is the most common cause of board failure in new installations and is NOT COVERED BY WARRANTY!
2. No accessory equipment is installed in the control box.
3. All wires attached to the 22 position terminal strip on the control box are well clear of the motor V-belt and the limit switches.
4. The junction box cover is securely fastened.

CHECKING THE INDICATOR LIGHTS

There are 16 indicator lights on the control board of the LPX1000 operator. See Figure 22. These lights are used to verify proper operation of the LPX1000.

Remove the white high voltage connector from the control board.

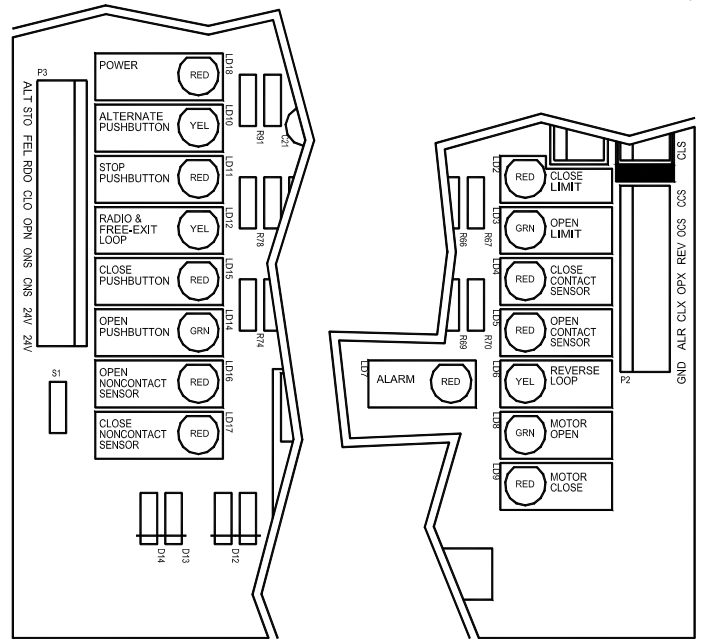
Turn all 3 digit switches ON for the test mode.

TURN ON THE MAIN POWER SWITCH

- Note that the “POWER” lamp is lighted. This indicates that power is applied to the control board and the power supply is functioning
- Connect one end of a short piece of wire (not supplied) to terminal #16 (COMMON).
- With the other end of this wire, (make sure that this loose end is free of insulation), touch the following terminals and observe the noted response of the lamps.

1. Manually activate the Close Limit Switch: Close Limit Switch light is ON.
2. Manually activate the Open Limit Switch: Open Limit Switch light is ON.
3. Connect to Terminal #4, Radio Open.: Radio Open light is ON, Motor Open light is ON.
4. Remove wire from Terminal #4, Radio Open. Radio Open light goes OUT, Motor Open light stays ON.
5. Connect to Terminal #8, Stop : Both Motor Open and Motor Close lights are momentarily ON, then both Motor Open and Motor Close lights go OUT. The Stop Pushbutton light is ON as long as the wire is held on the terminal and the goes OUT when the wire is removed.
6. Connect to Terminal #7, Close.: Observe that the Motor Close light comes ON and the Close Pushbutton light is ON. Remove the wire from terminal #7 and observe that the Close Pushbutton light goes OUT and the Motor Close light stays ON.
7. Connect to Terminal #11, Reversing Loop,: Observe that both Motor lights are ON momentarily and then the Motor Close light goes OUT and the Motor Open light stays ON.
8. Connect to Terminal #8, Stop,: Same as above, Sequence 5.
9. Connect to Terminal #3, Alternate: Alternate light is ON, Motor Close light is ON. Remove wire and note that the Alternate light

110127



INDICATOR LAMPS

Figure 22: Indicator Lamps

goes OUT but the Motor Close light stays ON.

10. Connect to Terminal #3, Alternate again: Note that the Alternate light comes ON, that the Motor Close light goes OUT and that the Motor Open light comes ON.
11. Connect to Terminal #6, Open: Observe that the Motor Open light comes ON and the Open Pushbutton light is ON. Remove the wire from terminal #6 and observe that the Open Pushbutton light goes OUT and the Motor Open light stays ON.
12. Connect to Terminal #9, Open Non-contact Sensor: Note that the Open Non-contact Sensor light comes on & remains on until the connection is removed. Observe that the both Motor Open and Motor Close lights are momentarily ON, then the Motor Open light goes out and the Motor Close light stays on for approximately 1 second then goes out.
13. Connect to Terminal #6, Open: Same as above, Sequence #11.
14. Connect to Terminal #12, Open Contact Sensor: Note that the Open Contact Sensor light comes on & remains on until the connection is removed. Observe that the both Motor Open and Motor Close lights are momentarily ON, then the Motor Open light goes out and the Motor Close light stays on for approximately 1 second then goes out.
15. Connect to Terminal #7, Close: Same as above Sequence #6.
16. Connect to Terminal #10, Close Non-contact Sensor: Note that the Close Non-contact Sensor light comes on & remains on until the connection is removed. Observe that the both Motor Open and Motor Close lights are momentarily ON, then the Motor Close light goes out and the Motor Open light stays on for approximately 1 second then goes out.



- 17. Connect to Terminal #7, Close: Same as above Sequence #6. Connect to Terminal #13, Close Contact Sensor: Note that the Close Contact Sensor light comes on & remains on until the connection is removed. Observe that the both Motor Open and Motor Close lights are momentarily ON, then the Motor Close light goes out and the Motor Open light stays on for approximately 1 second then goes out.

CHECK OF THE INDICATOR LAMPS HAS BEEN COMPLETED.

IF THE INDICATOR TEST PERFORMED SATISFACTORILY, TURN OFF THE AC POWER SWITCH AT THE LPX1000 CONTROL BOX AND RECONNECT THE WHITE HIGH VOLTAGE HARNESS CONNECTOR TO THE CONTROL BOARD. RESET THE SWITCH SELECTABLE OPTIONS (S1, S2, S3) ACCORDING TO FUNCTION DESIRED (SEE PAGE 14 AND 15).


FINAL SETTING OF THE LIMIT SWITCHES

If the gate stops short of being fully open or closed or if it bangs against the end stops, turn off the main power and reset the appropriate limit switch nut. Each slot on the limit nuts represents about 1" of gate travel. The nuts should only have to be turned one or two slots in either direction to fine tune the gate's limits of travel. When final adjustment has been completed, insure that the detent plate is firmly seated in the slots. Review Figure 18, Page 16.

FINAL SETTING OF THE CLOSE TIMER

To adjust the amount of time the close timer will hold the gate open, use the trimmer potentiometer on the controller board. Review Figure 21, Page 17.

Close timer delay is adjustable between 2 and 60 seconds. Turning the potentiometer clockwise increases the delay; turning it counterclockwise decreases the delay.

 **WARNING!**

RISK OF ENTRAPMENT

OVERLOAD SENSITIVITY HAS NOT BEEN SET. DO NOT ALLOW ANYONE NEAR THE GATE AND DO NOT LEAVE GATE AND LPX1000 UNATTENDED UNTIL THE FOLLOWING PROCEDURES HAVE BEEN COMPLETED.

FINAL SETTING OF THE OBSTRUCTION DETECTION OVERLOAD FORCE

The Obstruction Detection Overload Force was preset before turning on the main power to prevent the operator from "self-tripping" during testing. To set the OPEN Overload Force, start the gate in motion in

the Open direction and turn the overload potentiometer counterclockwise until the gate stops and reverses. Then back the potentiometer off 10 degrees in the clockwise direction. Review Figure 19, Page 16.

Repeat for the Close Overload Force.

CAUTION: During this process the alarm will sound if the overload sensor is activated two sequential times before the gate reaches a limit (open or close). To reset the alarm sensor use constant pressure on a control button connected to the OPEN or CLOSE input and move the gate to a fully open or closed position or turn off and restore the power to the operator.

Restart the gate and give the leading edge a firm blow with the heel of your palm. Don't stand directly in the gate's path while testing the Overload Force. The obstruction detection should respond immediately to the blow, the gate will pause and reverse approximately two inches. The overload potentiometer must be adjusted to the least force setting possible without causing "self-tripping" due to the gate's inherent friction or to variations in the track. Try readjusting the potentiometer several times by small increments, testing the gate in both directions of travel, until you are satisfied. Additional allowance must be made for high wind area applications.

TO THE END USER: Test your obstruction detection overload force on a monthly basis and have a qualified technician readjust for least force setting as necessary.

TESTING THE OPERATOR LOCK

For LPX1000 models without "S" suffix the operator lock is only active when the operator is powered and the GATE CLOSED light is on (gate is fully closed).

When power is OFF, the lock is not energized and the gate may be pushed open manually.

For LPX1000 models with "S" suffix, the lock mechanism engages whenever the operator is not moving the gate (Fail Secure Lock). Manual operation of the gate requires mechanically disengaging the lock, see page 24.

SMART™ SETTING - SELF ADJUSTING MAXIMUM RUN TIMER

The LPX1000 is equipped with a Self adjusting M^Aximum Run Timer, SMART™, that will turn the LPX1000 OFF if a Limit Switch command is not received within a few seconds of the time required to fully Open or Close the gate. Valid commands received during the cycle, such as activation of the OVERLOAD or a new input command, will automatically reset and restart the MRT.

To set the SMART™ Maximum Run Time and check that the limits are properly adjusted, fully open and close the gate five (5) times. The control board will sense the time required and add approximately two seconds.



BI-PARTING INSTALLATION FINAL SETTINGS

LIMIT SWITCHES - Push both gates together in the center of the driveway to set the closed limits. Push each gate open an equal amount to set the open limits. After cycling the gates the settings can be fine tuned to insure that the gates stop in their open positions at the same time. **SWITCH SELECTABLE OPTIONS** - Make sure the selectable option on switch #3 is set in the ON position for the primary operator and the OFF position for the secondary operator. Set the primary operator's other two switches to the desired position according to the functions required. The settings of the secondary operator's other switches must be OFF.

When properly adjusted, the two operators will perform as if they were a true Master/Slave installation. If the motor overload circuit in one operator should respond to an obstruction not encountered by the other, the gates will temporarily get out of sync. Synchronization will be restored after the next input command cycle.

TERMINAL STRIP REFERENCE CHART

#	NAME	DESCRIPTION
A	FREE EXIT LOOP	Continuous Signal, connected directly to the loop socket block. Connect one end of the free exit loop wire here, the other end connects to Terminal B.
B	FREE EXIT LOOP	Continuous Signal, connected directly to the loop socket block. Connect one end of the free exit loop wire here, the other end connects to Terminal A.
C	REVERSING LOOP	Continuous Signal, connected directly to the loop socket block. Connect one end of the reversing loop wire here, the other end connects to Terminal D.
D	REVERSING LOOP	Continuous Signal, connected directly to the loop socket block. Connect one end of the reversing loop wire here, the other end connects to Terminal C.

**PROVEN
CGA2K™
TECHNOLOGY**

TERMINAL STRIP REFERENCE CHART

#	NAME	DESCRIPTION
1	24 VAC	Provides maximum 10 VA auxiliary power for accessories.
2	24 VAC	Provides maximum 10 VA auxiliary power for accessories.
3	ALTERNATE	Momentary input, must be released and re-entered to be recognized. This input is used for "COMMAND OPEN/COMMAND CLOSE" applications. The 1st signal will cause the gate to begin opening. A 2nd signal received during the open cycle will stop the gate immediately. A 3rd signal will close the gate. Connect appropriate access control devices to this terminal and #16 COMMON. Disable the Close Timer (rotate pot fully counter-clockwise).
4	RADIO OPEN	Momentary input, must be released and re-entered to be recognized. Once activated the gate will open fully. Activation while the gate is closing will cause it to re-open.
5	FREE EXIT	Momentary or continuous input. Preferred terminal for most HOLD OPEN functions. Direct input to control system, independent of the Loop Sockets. Once activated the gate will open fully. Activation while the gate is closing will cause it to re-open. Continuous activation while the gate is open will prevent the Timer-To-Close function from automatically closing the gate.
6	OPEN	Momentary or continuous signal. On/Off mode set by Switch #1 WITH SWITCH 1 ON: Once activated the gate will open fully. Activation while the gate is closing will cause it to re-open. Continuous activation while the gate is open will prevent the Timer-To-Close function from automatically closing the gate. Continuous signal required to move the gate when in the alarm mode. WITH SWITCH 1 OFF: Gate does not respond to pushbutton input when in the normal mode. Continuous signal required to move the gate when in the alarm mode.

Terminal Strip Reference Chart continued on next page →



TERMINAL STRIP REFERENCE CHART

#	NAME	DESCRIPTION
7	CLOSE	Momentary or continuous signal. On/Off mode set by Switch #1 WITH SWITCH 1 OFF: Once activated the gate will close fully. Activation while the gate is opening has no effect. Continuous signal required to move the gate when in the alarm mode. WITH SWITCH 1 ON: Gate does not respond to pushbutton input when in the normal mode. Continuous signal required to move the gate when in the alarm mode.
8	STOP	Momentary or continuous signal. Overrides all other signals. Once activated, the gate will immediately stop and await a new command. If the STOP input is continuously activated, the gate will not move.
9	OPEN PHOTO	Momentary or continuous signal. This input is active only when referenced to the opening direction, it has no effect on the gate when closing or about to close. If activated when the gate is opening the gate will stop, pause and reverse in the close direction for 1/2 second (approx. 2 inches) and stop. Continuous activation will prevent the gate from moving in the open direction. When the input is removed normal operation is resumed. This input is intended for photoelectric eye systems and other non-contact devices as appropriate. Connect here and to terminal #16 COMMON. Multiple devices may be connected in parallel.
10	CLOSE PHOTO	Momentary or continuous signal. This input is active only when referenced to the closing direction, it has no effect on the gate when opening or about to open. If activated when the gate is closing the gate will stop, pause and reverse in the open direction for 1/2 second (approx. 2 inches) and stop. Continuous activation will prevent the gate from moving in the close direction. When the input is removed normal operation is resumed. If the Timer-To-Close function initiated the close movement and Switch S2 (Re-close) is ON, the gate will automatically re-close from a partially closed position after the input to Close Photo is removed. Continuous activation while the gate is open will prevent the Timer-To-Close function (if enabled) from automatically closing the gate. This input is intended for photoelectric eye systems and other non-contact devices as appropriate. Connect here and to terminal #16 COMMON. Multiple devices may be connected in parallel.
11	REVERSE	Momentary or continuous signal. This input is active only when the gate is closing or when it's fully open and the Close Timer is operative. All stand-alone vehicle detectors, photo-eyes and active edges should be connected here and to terminals #16 COMMON. Multiple devices may be connected in parallel.

#	NAME	DESCRIPTION
12	OPEN EDGE	Momentary or continuous signal. This input is active only when referenced to the opening direction, it has no effect on the gate when closing or about to close. If activated when the gate is opening the gate will stop, pause and reverse in the close direction for 1/2 second (approx. 2 inches) and stop. Continuous activation will prevent the gate from moving in the open direction. If a second activation occurs before the limit switch is activated the gate will stop and a require a renewed, intended input to move in the open direction and before an automatic activation device (timer, etc.) will operate. This input is intended for Electric Gate Edge systems and other minimum-contact devices as appropriate. Connect here and to terminal #16 COMMON. Multiple devices may be connected in parallel.
13	CLOSE EDGE	Momentary or continuous signal. This input is active only when referenced to the closing direction, it has no effect on the gate when opening or about to open. If activated when the gate is closing the gate will stop, pause and reverse in the open direction for 1/2 second (approx. 2 inches) and stop. Continuous activation will prevent the gate from moving in the close direction. Continuous activation while the gate is open will prevent the Timer-To-Close function (if enabled) from automatically closing the gate. If a second activation occurs before the limit switch is activated the gate will stop and a require a renewed, intended input to move in the close direction and before an automatic activation device (timer, etc.) will operate. This input is intended for Electric Gate Edge systems and other minimum-contact devices as appropriate. Connect here and to terminal #16 COMMON. Multiple devices may be connected in parallel.
14	MASTER OPEN	Momentary or continuous signal. Master (output configuration). This terminal is used to coordinate two independent systems (two control box/mechanical unit combinations controlling separate gate leaves). Connects to terminal #6 (OPEN) in the companion control box and controls the direction of movement in the companion box (Switch S3 ON).
15	MASTER CLOSE	Momentary or continuous signal. Master (output configuration). This terminal is used to coordinate two independent systems controlling separate gate leaves. Connects to terminal #7 (CLOSE) in the companion control box and controls the direction of movement in the companion box (Switch S3 ON).
16	COMMON	Common connection for low voltage signal inputs, terminals 3 through 15.



TESTING THE VEHICLE LOOP DETECTORS

1. REVERSING LOOP VEHICLE DETECTOR:

Pre-test: Pre-test the vehicle detector independently using the presence lamp on the front panel of the detector and a metal plate over the loop. When you are satisfied that the detector is working properly, connect the loop wires to terminals C and D, "REV LOOP", on the control panel of the LPX1000. More than one loop may be connected to terminals C and D if desired, the operator reacts the same way when a vehicle runs over either loop.

Loop Full Function Test: Give the gate an open command and allow the close timer to start the gate to close. Place the metal plate over the loop and observe that the "REVERSING LOOP" light comes ON the operator control board and the gate reopens.

2. FREE EXIT VEHICLE DETECTOR:

Pre-test: Test the vehicle detector independently using the presence lamp on the front panel of the detector and a metal plate over the loop. When you are satisfied that the detector is working properly, connect the loop wires to terminals B and C, "REV LOOP", on the control panel of the LPX1000.

Loop Full Function Test: Place the metal plate over the FREE EXIT LOOP and observe that the gate opens to the fully open position. Leave the metal plate on the loop for at least one minute. Observe that the gate does not close. Remove the plate from the loop and observe that the gate closes. (Some vehicle detectors will "tune out" a constant obstruction to the loop after 15 to 30 minutes.)



E: END USER INSTRUCTIONS GATE OPENER OPERATION & SAFETY GUIDE

IMPORTANT SAFETY INSTRUCTIONS



WARNING!

TO REDUCE THE RISK OF SEVERE INJURY OR DEATH

1. READ AND FOLLOW ALL INSTRUCTIONS AND WARNINGS IN THIS MANUAL.
2. Never let children operate or play with gate controls. Keep the remote control away from children.
3. Always keep people and objects away from the gate. NO ONE SHOULD CROSS THE PATH OF THE MOVING GATE.
4. Test the gate operator monthly. The gate MUST reverse on contact with a rigid object or stop when an object activates the non-contact sensor. After adjusting the force or the limit of travel, retest the gate operator. Failure to adjust and retest the gate operator properly can increase the risk of injury or death.
5. Use the emergency release (if applicable on this operator) only when the gate is not moving.
6. KEEP GATES PROPERLY MAINTAINED. Read the owner's manual. Have a qualified service person make repairs to gate hardware.
7. The entrance is for vehicles only. Pedestrians must use separate entrance.
8. SAVE THESE INSTRUCTIONS.



BASIC OPERATIONAL GUIDE

- If the gate is fully closed an Open Button, Alternate, Radio or Free Exit input will cause the gate to begin moving in the open direction.
- If the gate is fully open a Close Button, Alternate, or Radio input will cause the gate to begin moving in the close direction.
- If the gate is moving in a Close direction a Close Non-Contact Sensor, Close Contact Sensor input or a Close Overload activation will cause the gate to stop, pause and reverse for approximately 2 inches in the Open direction.
- If the gate is moving in a Close direction an Open Button, Radio, Reversing, or Free Exit Loop input will cause the gate to stop, pause, reverse and run in the Open direction.
- If the gate is moving in a Close direction a Stop Button or Alternate input will cause the gate to stop. A subsequent Alternate input will cause the gate to begin moving in the Open direction.
- If the gate is moving in an Open direction an Open Non-Contact Sensor, Open Contact Sensor input or an Open Overload activation will cause the gate to stop, pause and reverse for approximately 2 inches in the Open direction.
- If the gate is moving in an Open direction a Stop or Alternate input will cause the gate to stop. A subsequent Alternate input will cause the gate to begin moving in the Close direction.
- Two sequential activations of the Overload detector (Open or Close direction) before the gate reaches a limit will cause the operator to go into the alarm mode. To reset the operator remove the obstruction and either use constant pressure on a control button connected to the OPEN or CLOSE input and move the gate to a fully open or closed position or turn off and restore the power to the operator.

MANUAL OPERATION - Standard Lock Mechanism (lock activates only when the gate reaches the fully closed position). The gate can be moved open or close in case of power failure or other need to move the gate manually without disconnecting the operator chain. Remove power from the unit (if not already off) and firmly grasp the leading edge of the gate. Push or pull the gate in the direction desired. The amount of force required to move the gate will depend on the gate weight and the inherent friction of the overall system. Manual operation is possible without removing power when the gate is in any position except the closed position, but the lock will engage at the closed position and caution must be exercised as control inputs will be active and able to energize the operator.

MANUAL OPERATION - Fail Secure Lock Mechanism (-S suffix), the lock is activated whenever the gate is not moving. The gate can be moved open or close in case of power failure or other need to move the gate manually without disconnecting the operator chain. Take off the operator cover by first removing any lock attached to the lock tab on the operator front then lift the cover over the tab and directly overhead off the unit. Remove power from the unit by turning the Main Power Switch on the 4 x 4 handy box (under the control box) to the OFF position or turn off power at the main circuit breaker box feed. Move the Manual Operation Actuator Lever to the RELEASE (UN-SECURE) position (see Figure 26) by pulling the lever up slightly to clear the tab and moving it toward the gate. Ensure the lever is resealed on the tab in the RELEASE (UN-SECURE) position. Firmly grasp the leading edge of the gate. Push or pull the gate in the direction desired. The amount of force required to move the gate will depend on the gate weight and the inherent friction of the overall system. Manual operation is to be attempted only when the operator is not moving the gate under power.

To place the unit back into RUN (SECURE) operation reverse the steps above. Before replacing the cover ensure the Manual Operation Actuator Lever is resealed on the tab in the RUN (SECURE) position and the Main Power Switch is moved to the ON position. Restore power at the main circuit breaker box feed (if applicable).

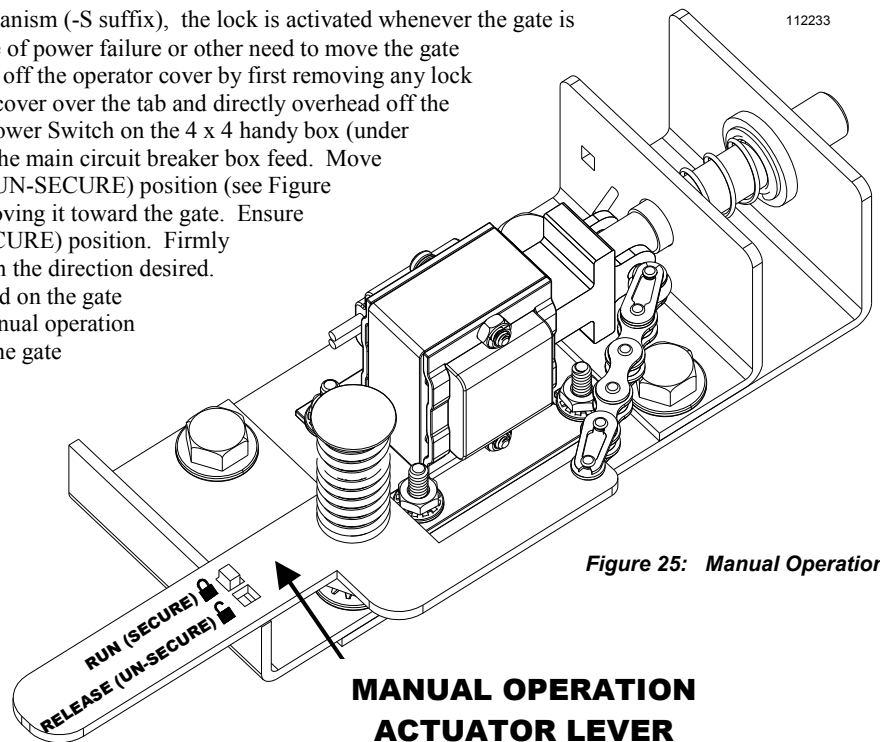


Figure 25: Manual Operation

**MANUAL OPERATION
ACTUATOR LEVER**



To the Owner/End User of the LPX1000 Gate Operator:

Thank you for choosing an Allstar Corp. product. We are confident you will have many years of use and satisfaction with your gate operator.

Our Gate Operator is part of your unique gate operating system, which may consist of a variety of components, including the gate, the gate tracks, posts, and electronic features. These components combined present certain risks and safety issues of which you, the end user, must be aware.

Each unique system presents a unique set of hazards which we cannot possibly address individually. These instructions will help you to identify the potential risks and safety issues your gate operator system presents, and guide you as you make your system as safe as possible for everyone who uses it.

Your first step is to consider the intended use of the gate system, who will be using the gate system, and in what manner the system is installed. You should have a clear understanding of how often the gate will be opened, who will be opening it, whether children and the general public will be near the gate system, and how close the gate system is to public property. Once you have answered these questions, you are ready to decide what safety measures must be taken to prevent injury.

To minimize the risk of entrapment in your gate system, install the following safety features:

- Electric gate edges
- Enclosed tracks
- Vertical guard posts
- Protective screen mesh
- Photoelectric sensors
- Instructional and precautionary signs
- Covers for exposed rollers

Each safety feature is a separate component in your gate system. Read and follow all instructions for each of the components of your unique system. **Ensure that all instructions for mechanical components, safety features and the LPX1000 Gate Operator are available for everyone who will be using your gate system.**

The two warning signs shipped with your Gate Operator (See Figure 2, Page 4 of this manual) must be installed in prominent positions on both sides of your gate. Keep them clean and legible.

Read and follow the safety points on this and the following page which present the basic guidelines for the safest operation of your gate operator system.

SAVE THESE INSTRUCTIONS !



ALL APPROPRIATE SAFETY FEATURES MUST BE INCORPORATED INTO YOUR GATE SYSTEM.

PRECAUTIONS FOR PEDESTRIAN TRAFFIC OR RESIDENTIAL AREAS



The internal operator overload sensor may not be adequate entrapment protection in all situations to prevent arm, leg, or hand injuries. Padded electric gate edges, roller guards, pneumatic gate edges, or photoelectric sensors are therefore necessary when automatic gates are used near pedestrian traffic. **Use of pedestrian walk gate is mandatory where there is nearby pedestrian traffic.**

107037

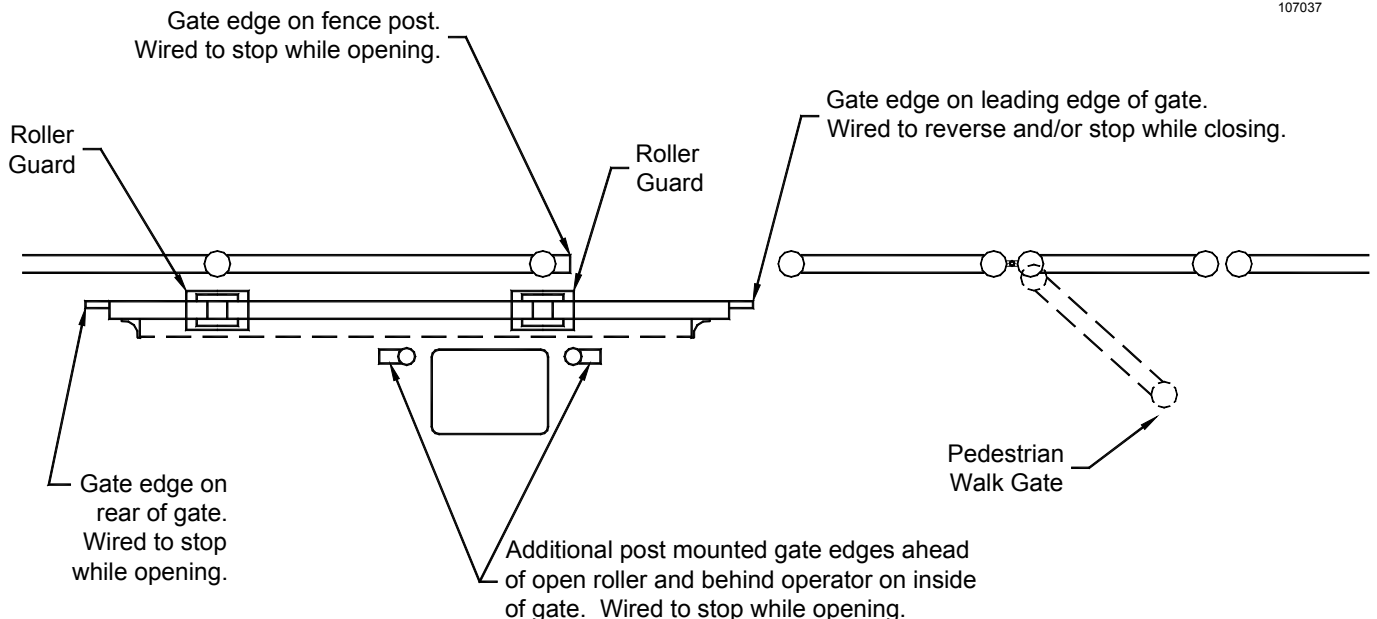


Figure 25: Entrapment Protection

26 | E: END USER INSTRUCTIONS

GATE OPENER OPERATION & SAFETY GUIDE



AVOID ENTRAPMENT: Stay away from the **path** of the gate and all moving parts (gate arms, etc.) at all times. Keep clear of the pinch points identified below. Install guards or other safety features to prevent access to pinch point areas. Install guards on open rollers.

NO CHILDREN OR PETS ALLOWED: Never allow a child to operate gate controls, “ride” a gate, or play in the area of a gate. **Install and store all controls out of children’s reach.** Also, pets must be kept away from the gate. Install a pedestrian gate in applications where children or pets need access. This entrance is for vehicles only. Pedestrians must use a separate entrance.

LOCATE MANUAL CONTROLS SAFELY: A manual control such as a pushbutton or keyswitch must be included in your gate system design to be used if automatic controls such as radio controls or loop detectors do not function. Carefully consider the placement of the manual control: It must be **out of reach of the gate** so that no one pushing the button or inserting the card is in the path of the gate or moving parts; it must also be **within sight of the gate** so that the operator can watch the gate and gate area during operation. **The recommended minimum distance between the gate or fence and manual control accessory is 10 feet.**

INSTALL SAFETY DEVICES: In residential applications or in areas where pedestrians may be present, or if your gate closes automatically, be sure an electric edge(s) and/or a photoelectric sensor(s) has (have) been installed and is/are operating properly. These features are intended to detect pedestrian traffic and prevent injury or entrapment. Loop detectors may be installed to detect vehicular traffic and prevent vehicular damage.

KEEP GATE IN SIGHT: Never activate the gate unless it is in sight. Install mounted controls in full view of the gate. Be sure the gate area is clear before activating the gate, and watch the gate and gate area as the gate is in motion.

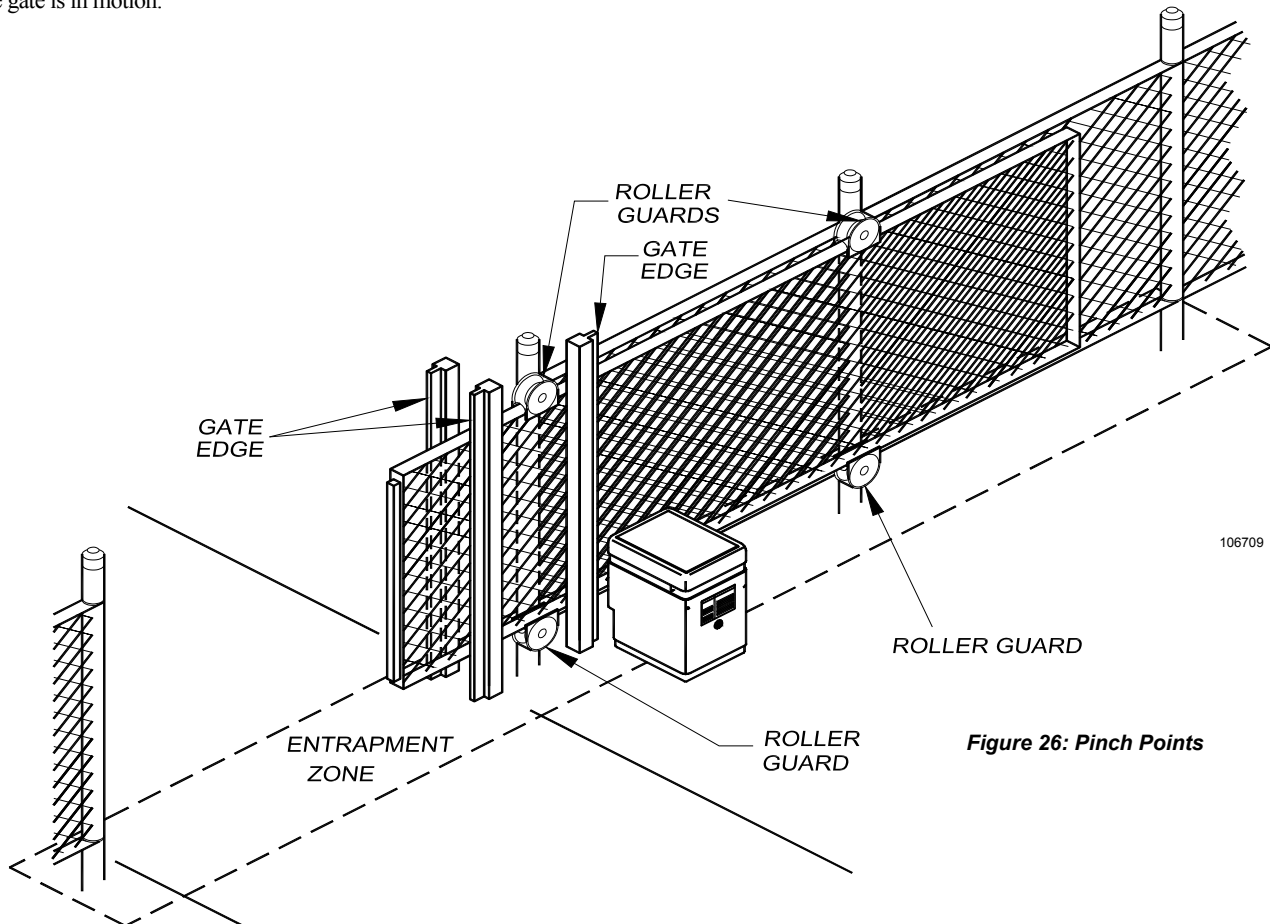
PREVENT PERSONAL INJURY OR DEATH: Do not stand near or on the gate. Gate may be activated without notice. Do not allow anyone to “ride” the gate, or place arms or legs through the gate. The force of the gate can cause serious personal injury or death. No one should cross the path of a moving gate.

VERY IMPORTANT: Test your obstruction detection **overload force** on a monthly basis and have a qualified technician readjust for **least force setting as necessary.**

MAINTAIN THE GATE AND GATE HARDWARE: A damaged gate or one that cannot be easily opened and closed manually must be repaired before installing a gate operator. A poorly operating gate may cause the load sensing device of the operator to fail, causing a risk of entrapment. **Never overtighten the clutch or load sensing device to compensate for a poorly operating slide gate.** Correct all mechanical problems on the gate and gate hardware before installing the gate operator. Have a qualified service technician make repairs to the gate and gate hardware.

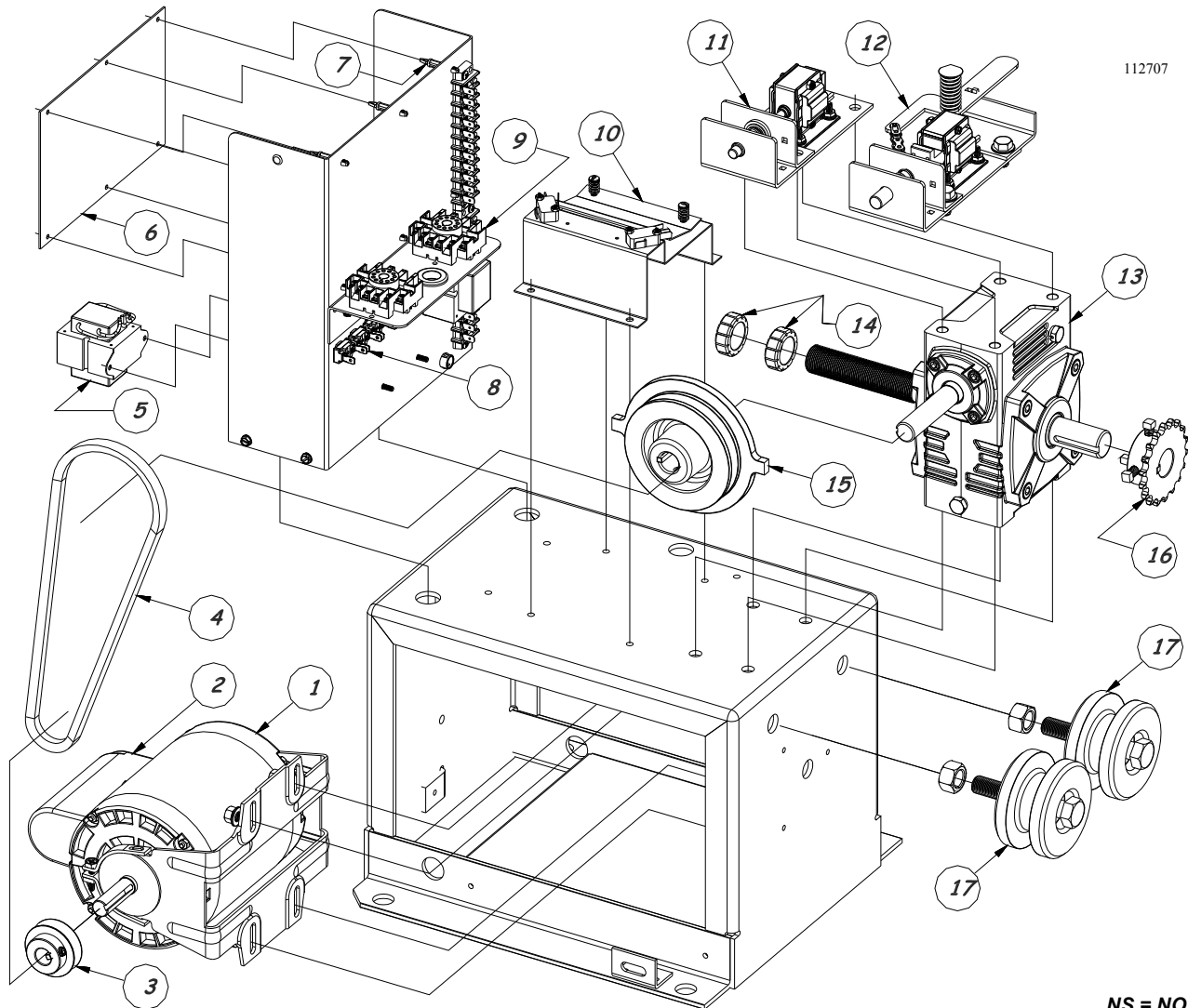
MAINTAIN ALL COMPONENTS OF GATE SYSTEM: Follow the maintenance instructions included with the gate, the gate operator, and the safety features and/or accessories that make up your gate operator system. Have a professional service technician perform any adjustments or maintenance to the components. **Fully test all safety features monthly. If faulty equipment is discovered or suspected, discontinue the use of the gate operator system immediately, and have the equipment serviced or replaced by a qualified service technician.**

The gate must reverse on contact with a solid, rigid object or when an object activates the non-contact sensors. After adjusting the force or limits of travel, retest the gate operator. Failure to adjust and retest the gate operator properly can increase the risk of injury or death.



106709

Figure 26: Pinch Points



NS = NOT SHOWN

Item	Part #	Description
1	010172	Motor,1/2 HP,56 FRM,115 VAC,ODP,PSC
2	010121	Capacitor,Motor,65 MFD,180VAC,Leeson 3014-13
3	010213	Motor Pulley, 4L
4	111814	V Belt,4L310
5	005244	Transformer,115-24 VAC,40 VA
6	110001	Motor Control Board,120V, Leader+
6a	112359	Motor Control Board,120V, LDR, High Speed
7	157149	Standoff, Motor Control Board
8	112726	Switch, Push Button, SPST, NO, Black
8a	111727	Switch, Push Button, SPST, NO, Red
9	111725	Socket, Octal,11 Pin, DIN/Panel MNTG
10	103829	Switch ASSY, Limit, LDR
10a	112032	Switch, SPDT, 15A/250V, SIMUL Roller Lever
11	102076	Lock Assembly, Solenoid, Cont. Duty, LDR
11a	102551	Solenoid, Lock, Push, 120 VAC

Item	Part #	Description
12	113366	Lock Assembly, Fail Secure Lock, CMPLT w/solenoid
12a	100879	Solenoid, 115 VAC, Horizontal Pull, 8# Max Pull
13	103427	Reducer, Speed, 10:1
14	010606	Limit Nut, 1 x 16
15	102077	Pulley, Lock PLT, Continuous Duty
16	110131	Sprocket, 41B18, 1" Thru Bore, 1/4 Key
16a	009136	Sprocket, 40B30, 1 TB, 1/4 Key, High Speed
17	104395	Pulley, Idler, UHMW, 3.5 OD
NS	110132	Receptacle, Duplex, Outlet/Switch, 120 VAC
NS	103671	Sign, Gate, Warning/OSHA
NS	111785	Manual, Installation/User, LPX1000
NS	112749	Cover Assembly, Operator, LPX1000
NS	010203	Chain, #41, Roller, 600P, 25 FT
NS	010209	Chain, #40, Roller, 600P, 25 FT, High Speed
NS	010272	Bracket, Chain Take-Up, Heavy Duty



PHYSICAL

PAD: 18-1/4" W x 18-1/4"D x 3"H Elevation
OVERHEAD CLEARANCE: Minimum 25" Required
UNIT SIZE: 15"W x 19"D x 24-1/4" H
FRAME: Welded, Uni-Body; Phosphatized And Painted to UL Standards
COVER: Architecturally Designed, Rust Free LLPE; Key Lock To Prevent Unauthorized Access
SHIPPING WEIGHT: 115 lbs.

ELECTRICAL

PRIMARY VOLTAGE: 115 VAC, 60 Hz, Single Phase
ELECTRICAL SOURCE: One 3-Wire, 15-Amp Service From Breaker Panel Required Per Operator
CONTROL VOLTAGE: 5 VDC
RADIO RECEIVER POWER: 24 VAC, 20 mA
MOTOR: 1/2 HP, 4.4 Amp, PSC, Instant Reversing, Thermally Protected (Manual Reset)
AUTO TIMER-TO-CLOSE: Built-In, Adjustable From 2-60 Seconds

DRIVE

DRIVE SYSTEM: Gearbox; 10:1; With Bronze Worm & Pinion Gears
TOTAL SPEED REDUCTION: 22.2:1
OUTPUT SHAFT: 1" dia., Ball-Bearing Mounted
DRIVE MECHANISM: 18-Tooth Sprocket; #41 Roller Chain 30-Tooth Sprocket; #41 Roller Chain High Speed Option, Class III & IV
LIMITS: Independent Open & Close; Displaced Cam With Micro-Switch Contacts; Adjustable Without Tools
OPERATOR LOCK: Electro-Mechanical, AC Solenoid; Engages On Close Limit, Drops Out If Power Is Interrupted

CAPACITIES

MAX. GATE WEIGHT: 1,300 lbs., Level Grade
MAX. GATE WIDTH: 35 ft. Maximum Standard 50 ft. Maximum High Speed Option Class III & IV
MAX. CYCLES PER HOUR: 45 Open/Close Per Hour; 800 Open/Close Per Day (All Calculations Based On Typical 20' Gate On Level Grade)
GATE SPEED: 11.8 inches/second 18 inches/second for High Speed Option (Class III and IV)

Specifications subject to change without notice. Consult the factory.

Manufacturer's Limited Warranty

Linear LLC warrants its Allstar brand gate operators to be free from defect in material and workmanship for a period of five (5) years from the date of purchase for single family home use and three (3) years from the date of purchase for multi-family and commercial use. This warranty covers all components except the electronic circuit boards which are warranted for three (3) years from the date of purchase for single family home use and two (2) years from the date of purchase for multi-family and commercial use. To obtain service contact your dealer.

To obtain service under this warranty the buyer must obtain authorization instructions for the return of any goods from Linear before returning the goods. The goods must be returned with complete identification, with copy of proof-of-purchase, freight prepaid and in accordance with Linear's instructions or they will not be accepted. In no event will Linear be responsible for goods returned without proper authorization or identification.

Goods returned to Linear for warranty repair within the warranty period, which upon receipt by Linear are confirmed to be defective and covered by this limited warranty, will be repaired or replaced at Linear's sole option, at no cost and returned pre-paid. Defective parts will be repaired or replaced with new or factory rebuilt parts at Linear's sole option.

This limited warranty does not cover non-defect damage, damage caused by unreasonable use, damage caused by improper installation or care, vandalism or lightning, fire or excessive heat, flood or other acts of God (including, but not limited to misuse, abuse or alterations, failure to provide reasonable and necessary maintenance), labor charges for dismantling or reinstalling a repaired or replaced unit, or replacement batteries.

These warranties are in lieu of all other warranties, either expressed or implied. All implied warranties of merchantability and/or fitness for a particular purpose are hereby disclaimed and excluded. Under no circumstances shall Linear be liable for consequential, incidental or special damages arising in connection with the use or inability to use this product. In no event shall Linear's liability for breach of warranty, breach of contract, negligence or strict liability exceed the cost of the product covered hereby. No person is authorized to assume for the Linear any other liability in connection with the sale of this product.

This warranty gives you specific legal rights. You may also have other rights which vary from state to state. Warranty effective after October 1st, 2007.

For Information:
877-441-9300 800-421-1587 www.allstarcorp.com

This Gate Operator is built in the USA and complies with all requirements of ANSI/UL Standard 325.