

Linear ACCESS™

AccessPro®

AP-4

Wireless Access Control Receiver

Installation Instructions

Linear

(760) 438-7000 • FAX (760) 438-7043
USA & Canada (800) 421-1587 & (800) 392-0123
Toll Free FAX (800) 468-1340
www.linearcorp.com

MEGACODE®



INTRODUCTION

The AP-4 is designed for a broad range of access control applications. Its wireless design and small size make it easily adaptable for a variety of access control requirements. Typically, the AP-4 is used to control a door strike, barrier gate, automatic gate or automatic door operator.

The AP-4 contains a high-gain UHF receiver which uses an external antenna to pick up signals from up to 250 feet away. Up to 480 Linear MegaCode® transmitters and one Model MGT safety edge transmitter can be programmed into the AP-4's memory. The AP-4 will retain its memory, even without power.

Two dry contact relay outputs are provided. One relay is the ACCESS RELAY (K1), which triggers for two seconds each time a programmed transmitter is activated. This relay output connects to the pushbutton or radio input of the access device. The second relay is the OBSTACLE RELAY (K2), which triggers for two seconds when an obstacle signal is sent from a Model MGT safety edge transmitter. This relay output connects to the obstacle input of the access device. An OPEN REQUEST input terminal is supplied for hardwired activation of the access device with an external pushbutton or keyswitch.

The AP-4 can be powered from 12-24 Volts AC or DC. The Form C relay outputs can switch up to 1 Amp each. An EARTH GROUND terminal is provided as an optional connection for maximum lightning and static protection.

Three utility functions can be displayed by pressing the pound (#) key then the digits 1-3. The utility functions display the status of the obstacle transmitter (#1), the total number of transmitters programmed (#2), and the total number of transmitter ID blocks programmed (#3).

The AP-4 can fully supervise the MGT safety edge transmitter. The system monitors the MGT transmitter for hourly status reports, tamper signals, and low battery signals. A beep will sound every 5 seconds if a fault occurs and the trouble source can be displayed by pressing pound-one (#1). **A transmitter must be activated twice to trigger the ACCESS RELAY if a supervisory trouble condition exists on the MGT transmitter** (unless the MGT has been suspended). To clear the supervisory trouble after servicing, press the CANCEL button.

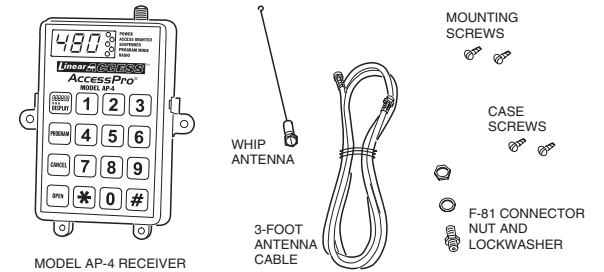

SAFETY WARNING

! WARNING !

MOVING DOOR OR GATE CAN CAUSE SERIOUS INJURY OR DEATH



THIS UNIT CAUSES OPERATION OF A DOOR OR GATE MOTOR.

STAY CLEAR OF MOVING PARTS IF THIS UNIT IS MOUNTED INSIDE THE DOOR OR GATE OPERATOR!

STAY CLEAR OF THE DOOR/GATE OR DISCONNECT THE ACCESS RELAY WIRES WHEN PROGRAMMING OR SERVICING THIS UNIT!

AP-4 FEATURES

DIGITAL DISPLAY
DISPLAYS LAST 3 DIGITS OF THE TRANSMITTERS ID NUMBER DURING OPERATION AND PROGRAMMING. ALSO DISPLAYS MGT SUPERVISION STATUS AND SYSTEM UTILITY INFORMATION.

NUMERIC KEYPAD
FOR ENTERING TRANSMITTER ID NUMBERS, PROGRAMMING, AND UTILITY FUNCTION NUMBERS.

ANTENNA CONNECTOR
FOR DIRECT CONNECTION TO THE LOCAL WHIP ANTENNA OR, WITH A COAX CABLE, TO A REMOTE ANTENNA.

POWER INDICATOR
LIGHTS WHEN AC OR DC POWER IS APPLIED TO THE UNIT.

ACCESS GRANTED INDICATOR
LIGHTS WHEN THE ACCESS RELAY IS ENERGIZED.

SUSPENDED INDICATOR
LIGHTS WHEN A SIGNAL IS RECEIVED FROM A TRANSMITTER THAT HAS BEEN SUSPENDED FROM USE, AND WHEN SUSPENDING A TRANSMITTER.

PROGRAM MODE INDICATOR
LIGHTS WHEN THE UNIT IS IN PROGRAM MODE.

RADIO INDICATOR
LIGHTS WHEN A RADIO SIGNAL ON THE RECEIVER'S FREQUENCY IS DETECTED.

PROGRAM BUTTON
PUSH FOR 3 SECONDS TO ENTER PROGRAM MODE. PRESS MOMENTARILY TO EXIT PROGRAM MODE.

DISPLAY BUTTON
SHIFTS THE DISPLAY TO SHOW THE LEFT THREE DIGITS OF THE 6-DIGIT TRANSMITTER ID NUMBER DURING OPERATION OR PROGRAMMING.

CANCEL BUTTON
CLEARS THE KEYPAD AND DISPLAY IN CASE OF AN INCORRECT PROGRAMMING ENTRY. ALSO CLEARS ANY SUPERVISORY TROUBLE CODES FROM AN MGT OBSTACLE TRANSMITTER.

OPEN BUTTON
PUSH TO ACTIVATE THE ACCESS RELAY.

STAR (*) KEY
DISPLAYS THE ID NUMBER OF THE LAST TRANSMITTER ACTIVATED. (USE THE DISPLAY BUTTON TO VIEW THE LEFT THREE DIGITS OF THE ID NUMBER.)

POUND (#) KEY
PRESS # THEN 1-3 FOR UTILITY FUNCTIONS:
#-1 DISPLAYS THE MGT SUPERVISORY STATUS.
#-2 DISPLAYS NUMBER OF PROGRAMMED TRANSMITTERS.
#-3 DISPLAYS NUMBER OF PROGRAMMED TRANSMITTER ID BLOCKS.

ELECTRICAL CONNECTIONS

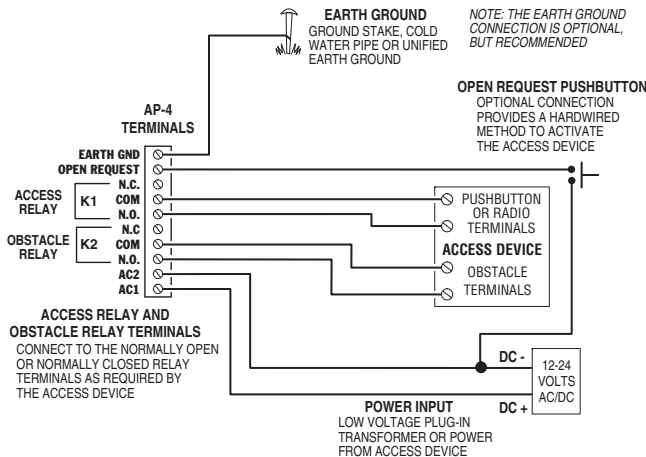

RECEIVER INSTALLATION

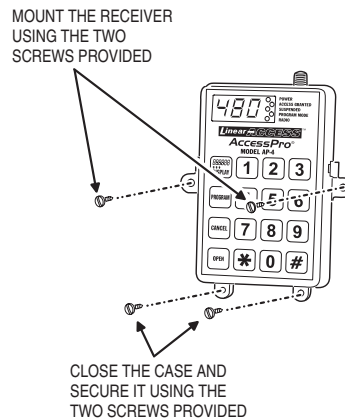

- NOTES:**
1. MOUNT RECEIVER IN AN AREA PROTECTED FROM THE ELEMENTS
 2. IF USING THE LOCAL WHIP ANTENNA, THE HIGHER THE RECEIVER IS MOUNTED, THE BETTER THE RADIO RANGE WILL BE
 3. OPTIONALLY, MOUNT THE RECEIVER IN A METAL CABINET AND USE AN EXTERNAL ANTENNA

ANTENNA INSTALLATION

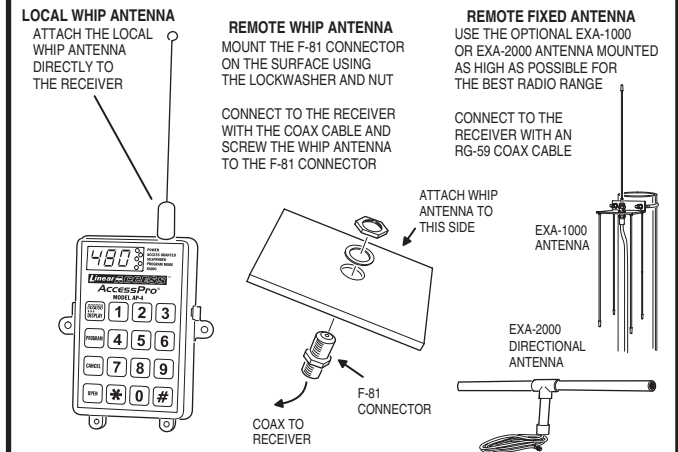

SET FACILITY CODES

USE THESE STEPS ONLY IF TRANSMITTER BLOCKS HAVE BEEN ORDERED WITH A PRE-SET FACILITY CODE

- STEP 1: PRESS **PROGRAM** FOR 3 SECONDS ← ENTERS PROGRAM MODE
- ↓
- DISPLAY: **P P P** THEN: **0 0 0** ← READY FOR PROGRAMMING
- ↓
- STEP 2: PRESS **1 0 #** ← FACILITY CODE FUNCTION NUMBER
- ↓
- STEP 3: PRESS **0 #** ← RECEIVER FACILITY CODE LOCATION (FROM 1-4)
- ↓
- STEP 4: PRESS **0 0 #** ← TRANSMITTER FACILITY CODE NUMBER (FROM 1-15; 0 = IGNORE FACILITY CODE)
- ↓
- STEP 5: PRESS **PROGRAM** ← EXITS PROGRAM MODE

NOTES:

1. REPEAT STEPS 2-4, IF REQUIRED, FOR EACH OF THE FOUR RECEIVER FACILITY CODE LOCATIONS
2. WHEN THE TRANSMITTER FACILITY CODE IS SET TO "0", THE RECEIVER WILL ACCEPT ALL TRANSMITTERS REGARDLESS OF THEIR FACILITY CODE

SET TRANSMITTER BUTTONS

USE THESE STEPS TO CHANGE WHICH BUTTONS ON MULTI-BUTTON TRANSMITTERS WILL ACTIVATE THE ACCESS RELAY

- STEP 1: PRESS **PROGRAM** FOR 3 SECONDS ← ENTERS PROGRAM MODE
- ↓
- DISPLAY: **P P P** THEN: **0 0 0** ← READY FOR PROGRAMMING
- ↓
- STEP 2: PRESS **2 0 #** ← TRANSMITTER BUTTON FUNCTION NUMBER (ENTER 21-25: 21 = LEFT; 22 = RIGHT; 23 = TOP; 24 = LOWER LEFT; 25 = LOWER RIGHT)
- ↓
- STEP 3: PRESS **1 #** OR **0 #** ← ENTER "1" TO ENABLE BUTTON ENTER "0" TO DISABLE BUTTON
- ↓
- STEP 4: PRESS **PROGRAM** ← EXITS PROGRAM MODE

NOTES:

1. THE FACTORY DEFAULT SETTING ONLY ALLOWS THE LEFT TRANSMITTER BUTTON TO ACTIVATE THE ACCESS RELAY
2. THE BUTTON SETTING WILL BE USED BY ALL TRANSMITTERS PROGRAMMED
3. REPEAT STEPS 2 & 3 TO PROGRAM OTHER BUTTONS

ADDING TRANSMITTERS

- STEP 1: PRESS **PROGRAM** FOR 3 SECONDS ← ENTERS PROGRAM MODE
- ↓
- DISPLAY: **P P P** THEN: **0 0 0** ← READY FOR PROGRAMMING
- ↓
- STEP 2: PRESS **3 0 #** ← TRANSMITTER ADDING FUNCTION NUMBER
- ↓
- STEP 3: PRESS **0 0 0 0 #** ← SINGLE TRANSMITTER ID # OR STARTING TRANSMITTER BLOCK ID # (FROM 1-65535)
- ↓
- STEP 4: PRESS **#** ← ENTERS ID #
- ↓
- SKIP TO STEP 6 FOR SINGLE TRANSMITTERS
- ↓
- STEP 5: PRESS **0 0 0 0 #** ← ENDING TRANSMITTER BLOCK ID # (FROM 1-65535)
- ↓
- STEP 6: PRESS **#** ← COMPLETE ID # ENTRY
- ↓
- REPEAT STEPS 2-6 TO ADD MORE TRANSMITTERS
- ↓
- STEP 7: PRESS **PROGRAM** ← EXITS PROGRAM MODE

NOTE:

IF THE TRANSMITTER ID # IS NOT LABELED ON A TRANSMITTER, TRIGGER THE TRANSMITTER TO VIEW THE ID # ON THE AP-4 DISPLAY. USE THE STAR KEY TO REVIEW THE LAST RECEIVED ID # (PRESS THE DISPLAY BUTTON TO VIEW THE LEFT THREE DIGITS OF THE ID #)

ACTIVATING/SUSPENDING TRANSMITTERS

- STEP 1: PRESS **PROGRAM** FOR 3 SECONDS ← ENTERS PROGRAM MODE
- ↓
- DISPLAY: **P P P** THEN: **0 0 0** ← READY FOR PROGRAMMING
- ↓
- STEP 2: PRESS **9 0 #** ← TRANSMITTER STATUS FUNCTION NUMBER
- ↓
- STEP 3: PRESS **0 0 0 0 #** ← TRANSMITTER ID # (FROM 1-65535)
- ↓
- STEP 4: PRESS **0 #** OR **1 #** ← ENTER "0" TO SUSPEND XMTR ENTER "1" TO ACTIVATE XMTR
- ↓
- STEP 5: PRESS **PROGRAM** ← EXITS PROGRAM MODE

NOTES:

1. REPEAT STEPS 2-4 TO SUSPEND OR ACTIVATE ADDITIONAL TRANSMITTERS
2. SUSPENDED TRANSMITTERS CAN NOT TRIGGER THE ACCESS RELAY, THE SUSPENDED INDICATOR WILL LIGHT INSTEAD
3. ACTIVATED TRANSMITTERS CAN TRIGGER THE ACCESS RELAY

REMOVING ALL TRANSMITTERS

- STEP 1: PRESS **PROGRAM** FOR 3 SECONDS ← ENTERS PROGRAM MODE
- ↓
- DISPLAY: **P P P** THEN: **0 0 0** ← READY FOR PROGRAMMING
- ↓
- STEP 2: PRESS **9 1 #** ← TRANSMITTER REMOVING FUNCTION NUMBER
- ↓
- STEP 3: PRESS **0 0 0 #** ← REMOVE COMMAND
- ↓
- STEP 4: PRESS **0 0 0 #** ← VERIFY REMOVE COMMAND
- ↓
- DISPLAY: **0 0 0** THEN: **0 0 0** ← MEMORY CLEAR
- ↓
- STEP 5: PRESS **PROGRAM** ← EXITS PROGRAM MODE

NOTES:

1. WARNING! ALL TRANSMITTERS INCLUDING THE MGT TRANSMITTER WILL BE REMOVED (TRANSMITTERS CANNOT BE INDIVIDUALLY REMOVED)
2. WARNING! ALL OTHER OPTIONS WILL BE RESET TO THE FACTORY DEFAULTS

ADDING AN MGT TRANSMITTER

- STEP 1: PRESS **PROGRAM** FOR 3 SECONDS ← ENTERS PROGRAM MODE
- ↓
- DISPLAY: **P P P** THEN: **0 0 0** ← READY FOR PROGRAMMING
- ↓
- STEP 2: PRESS **9 9 #** ← MGT TRANSMITTER ADDING FUNCTION NUMBER
- ↓
- STEP 3: PRESS **0 0 0 0 #** ← MGT TRANSMITTER ID # (FROM 1-65535)
- ↓
- STEP 4: PRESS **#** ← ENTERS MGT ID #
- ↓
- STEP 5: PRESS **PROGRAM** ← EXITS PROGRAM MODE

NOTE:

IF THE TRANSMITTER ID # IS NOT LABELED ON THE TRANSMITTER, TRIGGER THE TRANSMITTER TO VIEW THE ID # ON THE AP-4 DISPLAY. USE THE STAR KEY TO REVIEW THE LAST RECEIVED ID # (PRESS THE DISPLAY BUTTON TO VIEW THE LEFT THREE DIGITS OF THE ID #)

MGT TRANSMITTER SUPERVISION

IF THE AP-4 BEEPS EVERY 5 SECONDS, THE MGT HAS SENT A SUPERVISORY SIGNAL

- NOTE:** WHEN THE MGT HAS A SUPERVISORY CONDITION, TRANSMITTERS WILL HAVE TO BE TRIGGERED TWICE TO GAIN ACCESS
- PRESS **# 1** ← UTILITY FUNCTION #1 TO DISPLAY MGT STATUS
- ↓
- 0 - -** ← "L-" INDICATES MGT TRANSMITTER LOW BATTERY
- ↓
- F -** ← "-F-" INDICATES AN MGT TAMPER OR LOOP FAULT
- ↓
- - 5** ← "-S" INDICATES THAT HOURLY STATUS REPORTS HAVE NOT BEEN RECEIVED FROM THE MGT TRANSMITTER IN THE PREVIOUS FOUR HOURS
- ↓
- - -** ← AFTER CLEARING "..." INDICATES THAT NO SUPERVISORY CONDITIONS EXIST WITH THE MGT TRANSMITTER
- ↓
- PRESS **CANCEL** ← CLEARS MGT STATUS FROM AP-4 MEMORY AND STOPS BEEPER

SUSPENDING THE MGT TRANSMITTER

TO DISABLE THE MGT SUPERVISION AND PREVENT THE AP-4 FROM SOUNDING THE 5-SECOND MGT SUPERVISORY BEEPS

- STEP 1: PRESS **PROGRAM** FOR 3 SECONDS ← ENTERS PROGRAM MODE
- ↓
- DISPLAY: **P P P** THEN: **0 0 0** ← READY FOR PROGRAMMING
- ↓
- STEP 2: PRESS **9 8 #** ← MGT TRANSMITTER FUNCTION NUMBER
- ↓
- STEP 3: PRESS **9 9 9 #** ← SUSPEND/ACTIVATE COMMAND
- ↓
- DISPLAY: **P P P** THEN: **0 0 0** ← MGT SUPERVISION CHANGED (SUSPEND INDICATOR LIGHTS FOR 2 SECONDS WHEN MGT HAS BEEN SUSPENDED)
- ↓
- STEP 4: PRESS **PROGRAM** ← EXITS PROGRAM MODE

NOTES:

1. USE THE SAME COMMAND TO ACTIVATE (UNSPEND) THE MGT TRANSMITTER
2. SUSPENDING AN MGT WITH A SUPERVISORY CONDITION WILL ALLOW TRANSMITTERS TO GAIN ACCESS WITH ONE ACTIVATION INSTEAD OF TWO

REMOVING THE MGT TRANSMITTER

- STEP 1: PRESS **PROGRAM** FOR 3 SECONDS ← ENTERS PROGRAM MODE
- ↓
- DISPLAY: **P P P** THEN: **0 0 0** ← READY FOR PROGRAMMING
- ↓
- STEP 2: PRESS **9 8 #** ← MGT TRANSMITTER FUNCTION NUMBER
- ↓
- STEP 3: PRESS **0 0 0 #** ← REMOVE COMMAND
- ↓
- DISPLAY: **0 0 0** THEN: **0 0 0** ← MGT REMOVED
- ↓
- STEP 4: PRESS **PROGRAM** ← EXITS PROGRAM MODE

SYSTEM TESTING

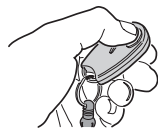

ACTIVATE A TRANSMITTER THAT HAS BEEN PROGRAMMED (AND IS NOT SUSPENDED)

THE RADIO AND ACCESS GRANTED INDICATORS SHOULD LIGHT AND THE ACCESS DEVICE SHOULD OPERATE

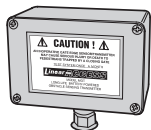

IF AN MGT OBSTACLE TRANSMITTER IS PROGRAMMED, RUN THE ACCESS DEVICE AND TRIGGER THE OBSTACLE SENSOR

VERIFY THAT THAT ACCESS DEVICE REVERSES

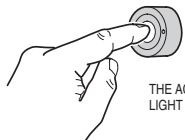

IF AN OPEN REQUEST PUSHBUTTON IS INSTALLED, PRESS IT

THE ACCESS GRANTED INDICATOR SHOULD LIGHT AND THE ACCESS DEVICE SHOULD OPERATE

SPECIFICATIONS

- Size: 4.5" W x 6.0" H x 1.5" D
- Supply Voltage: 12-24 Volts AC or DC
- Operating Current: 250 mA Maximum
- Operating Temperature Range: -22° to +158° F (-30° to 70° C)
- Sensitivity: -94 dBm Minimum
- Bandwidth (3 db): 4 MHz Typical
- Frequency: 318 MHz
- Relay Contact Rating: 1 Amp @ 24 Volts AC or DC
- Maximum # of Transmitters: 480
- Maximum # of Transmitter Blocks: 238
- Maximum # of Facility Codes: 4

LINEAR LIMITED WARRANTY

This Linear product is warranted against defects in material and workmanship for twenty-four (24) months. This warranty extends only to wholesale customers who buy direct from Linear or through Linear's normal distribution channels. Linear does not warrant this product to consumers. Consumers should inquire from their selling dealer as to the nature of the dealer's warranty, if any. There are no obligations or liabilities on the part of Linear corporation for consequential damages arising out of or in connection with use or performance of this product or other indirect damages with respect to loss of property, revenue, or profit, or cost of removal, installation, or reinstallation. All implied warranties, including implied warranties for merchantability and implied warranties for fitness, are valid only until the warranty expires. This Linear Corporation Warranty is in lieu of all other warranties express or implied.

All products returned for warranty service require a Return Product Authorization Number (RPA#). Contact Linear Technical Services at 1-800-421-1587 for an RPA# and other important details.

IMPORTANT!!!

Linear radio controls provide a reliable communications link and fill an important need in portable wireless signalling. However, there are some limitations which must be observed.

- The radios are required to comply with FCC Part 15 and Industry Canada Rules and Regulations. As such, they have limited transmitter power and therefore limited range.
- A receiver cannot respond to more than one transmitted signal at a time and may be blocked by radio signals that occur on or near their operating frequencies, regardless of code settings.
- Changes or modifications to the device may void FCC compliance.
- Infrequently used radio links should be tested regularly to protect against undetected interference or fault.
- A general knowledge of radio and its vagaries should be gained prior to acting as a wholesale distributor or dealer, and these facts should be communicated to the ultimate users.