

**Letron**

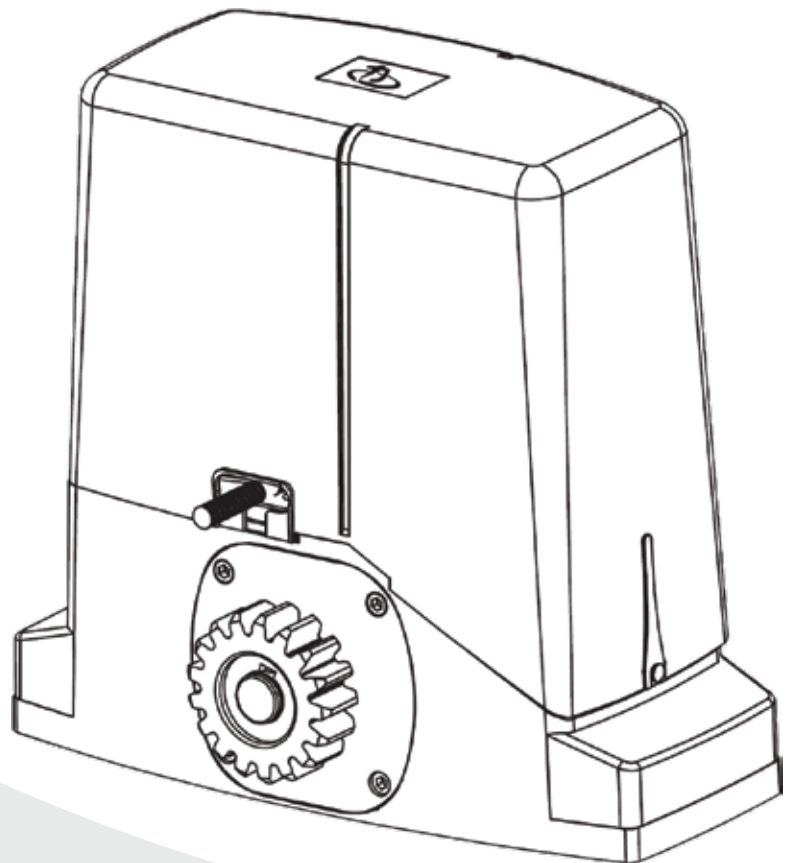

**LETRON** |  
**SL3000**

*Letron is world leading in automated gate systems  
in both design and manufacturing.*



# Contents

- Warranty.....1
- IMPORTANT SAFETY WARNINGS.....2
- Product Diagram.....3
- Features.....4
- Product Information.....5
- Installation.....6-16
- Troubleshooting.....17

# **WARRANTY**

**The warranty of this product commences from the date of purchase. The warranty is one year on the motor, three months warranty on Remote Control and six months on the battery.**

**Invoice must retain for warranty to be valid.**

**The warranty is a Back to Base Warranty that covers defects of materials to the unit under normal and correct use.**

**The unit must be correctly installed. If the gate is not open freely in a manual mode, damage may occur and may void your warranty.**

**If any problems arise within the warranty period, the customer must contact the place of purchase to rectify the problem.**

**It is the customers' responsibility to engage in periodic maintenance and check for loose wiring, gate movement in manual mode, greasing hinges, solar panel surface must be kept clean, loose bolts etc. The maintenance of the opener should be check every six months.**

**Failure to maintain the gate opener may result in your warranty to be void. The warranty does not cover damage by insects, water, battery, fuses, storm damage, improper use or undue force.**

**For a prolong use of the gate opener, periodic maintenance is highly recommended.**



## **IMPORTANT SAFETY WARNINGS - Please read these important safety warnings before installing or using this product**

---

- **Never let children operate or play with the controls.**
- **Keep the remote control away from the children.**
- **Do not operate the sliding gate unless the gate is in full view and free from objects such as cars, children or people.**
- **Always keep the moving gate in sight and away from any objects until it's completely opened/closed.**
- **No one should cross a moving gate.**
- **Do not disengage the slider gate motor to manual operation with anyone or any other objects, including motor vehicles, within the doorway.**
- **The slider gate must be well balanced. Sticking or binding gates can falsely trigger the obstruction sensing of the unit.**
- **All maintenance should be carried out by qualified personnel.**
- **Regularly test the slider gate motor to ensure that the obstruction sensor unit is operating properly.**
- **The slider gate motor has an electronic obstruction system that provides safe and reliable operation. It's however a legal requirement in some countries to also install a photo-electric sensor across the door way, please check this requirement with your local distributor. However, it's recommended to install this photo-electric sensor for all units.**

# Features

Your automatic Sliding Gate Motor has many features, which you will appreciate. The components and materials used in its control board are of the latest technology and highest quality.

The motor is used to drive a sliding gate, with the moving speed of 12 meters per minute. This gate operator is powered by AC15V. It is featured with powerful starting strength, capable of overload at short time. When it's overloaded, it's protected electrically and mechanically.

In case of power failure, a key can be used to release the motor and move the gates manually. Following lists some of its key features.

## OPERATION

To operate the sliding gate simply press the remote control handset or the wall mounted switch for two seconds and the gate will automatically open/close.

The gate can be stopped during on opening or closing cycle by pressing the remote control handset or wall switch. The next actuation will move the gate in the opposite direction.

## SAFETY OBSTRUCTION REVERSE

While the gate is performing closing cycle and it should hit an obstacle or be restricted in some manner, it will automatically reverse.

The amount of force the gate should encounter before reversing is adjustable. The gate will automatically stop if restricted whilst opening. The Safety Obstruction Forces should be checked at least once a month.

## SECURITY CODE STORE

The Sliding Gate Motor uses state of the art Microchip® technology in storing your Slider Code Transmitter Security Code.

Up to 20 different transmitters can be stored in the non-volatile memory device. To store any code simply press the LEARN button on the motor and press the transmitter button twice. The codes can be deleted at any time.

Security is enhanced because the fixed and encrypted sections combined increase the number of combinations to  $7.38 \times 10^9$ . There is no Dip switch on the motor which can be visually seen and copied.

## OPEN AND CLOSE DRIVE BUTTON

Another feature developed to aid in the installation of the Sliding Gate Motor is the O/S/C Button. This button is used to help set the open and close limit positions. A quicker time setting and a more precise limit position can be achieved using this system.

## AUTO CLOSE MODE

The Sliding Gate Motor can be programmed to automatically close at a selected period (eg. Thirty seconds) after the gate has opened. A photoelectric beam must be installed if this mode is selected.

## PHOTO ELECTRIC BEAM

The Sliding Gate Motor has an input for a Photo-Electric Beam to be connected for extra safety protection.

## SOLAR COMPATIBLE

This device is able to use 12V DC, 24V DC or 12V solar panel to operate.

# Product Information

## Standard Kits Contains

ITEMS	QUANTITY
Sliding Gate Motor	1
Battery	1
Transformer	1
Emergency Release Key	1
Instructional Manual	1
Line Switch Brackets	2
Remote Control Handset	2
Gear Rack	4 Meters
Photo-electric Beam	Optional (Highly Reccomended)

## Technical Specifications

Power supply: 24V AC Transformer or 12V Solar  
Starting current: < 4A  
Gate moving speed: 12M/Min  
Gate Length: 5m (max)  
Net weight: 15kg (including spare - parts)

# Product Diagram

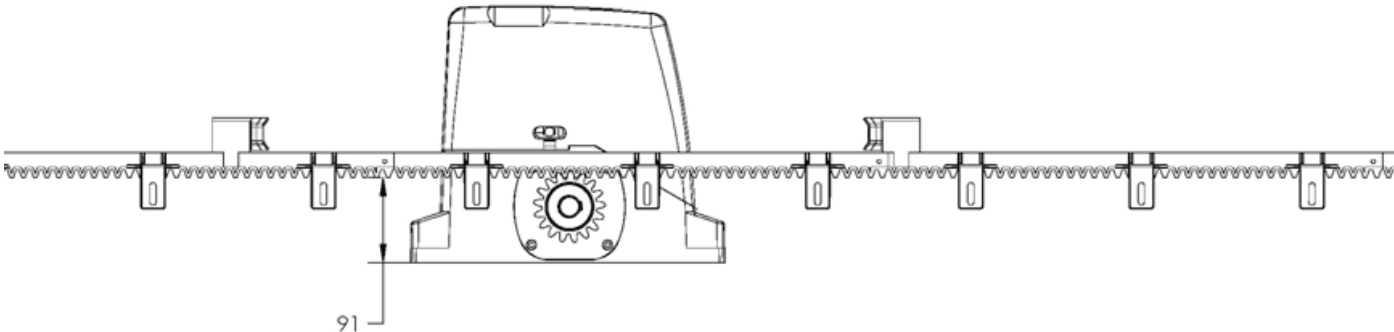
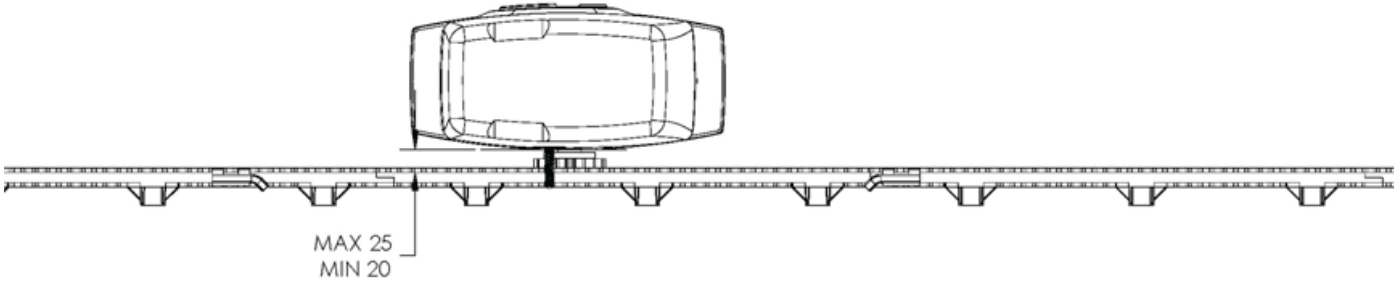
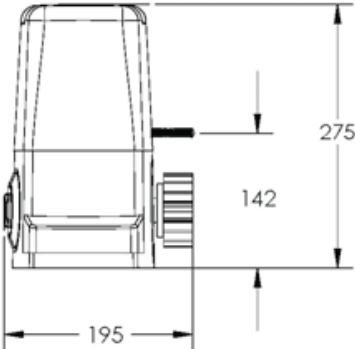
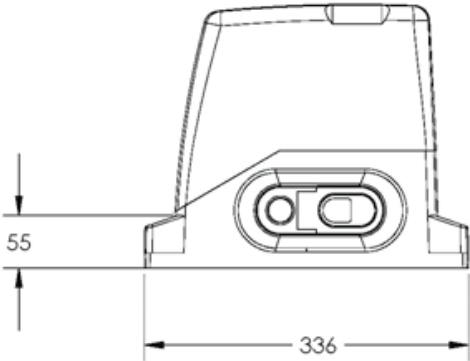
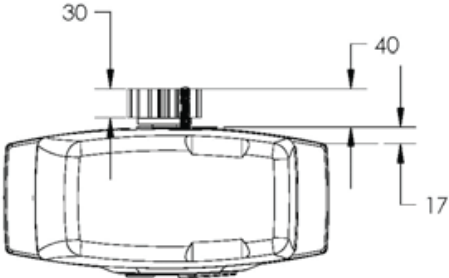

# Installation

If your motor is installed on the **RIGHT** as show below follow the wiring instructions below

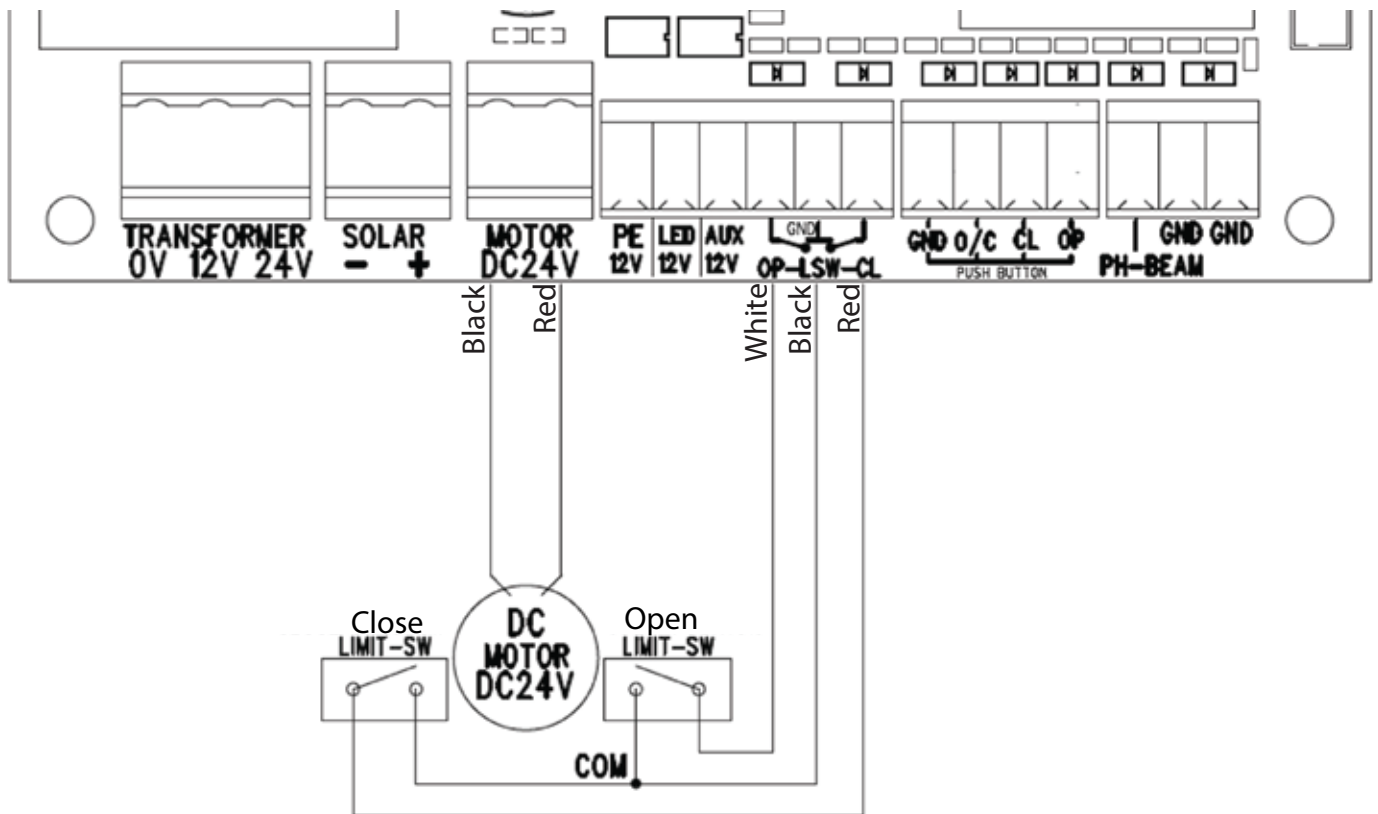

1. Connect the black cable(Motor cables) to to the first port of the MOTOR DC24V port.
2. Connect the red cable(Motor cables) to the second port of the MOTOR DC24V port.
3. Connect the white cable to OP(Limit Switch Cables).
4. Connect the black cable to LSW(Limit Switch Cables).
5. Connect the red cable to CL(Limit Switch Cables).



# Installation

If your motor is installed on the **LEFT** as show below follow the wiring instructions below

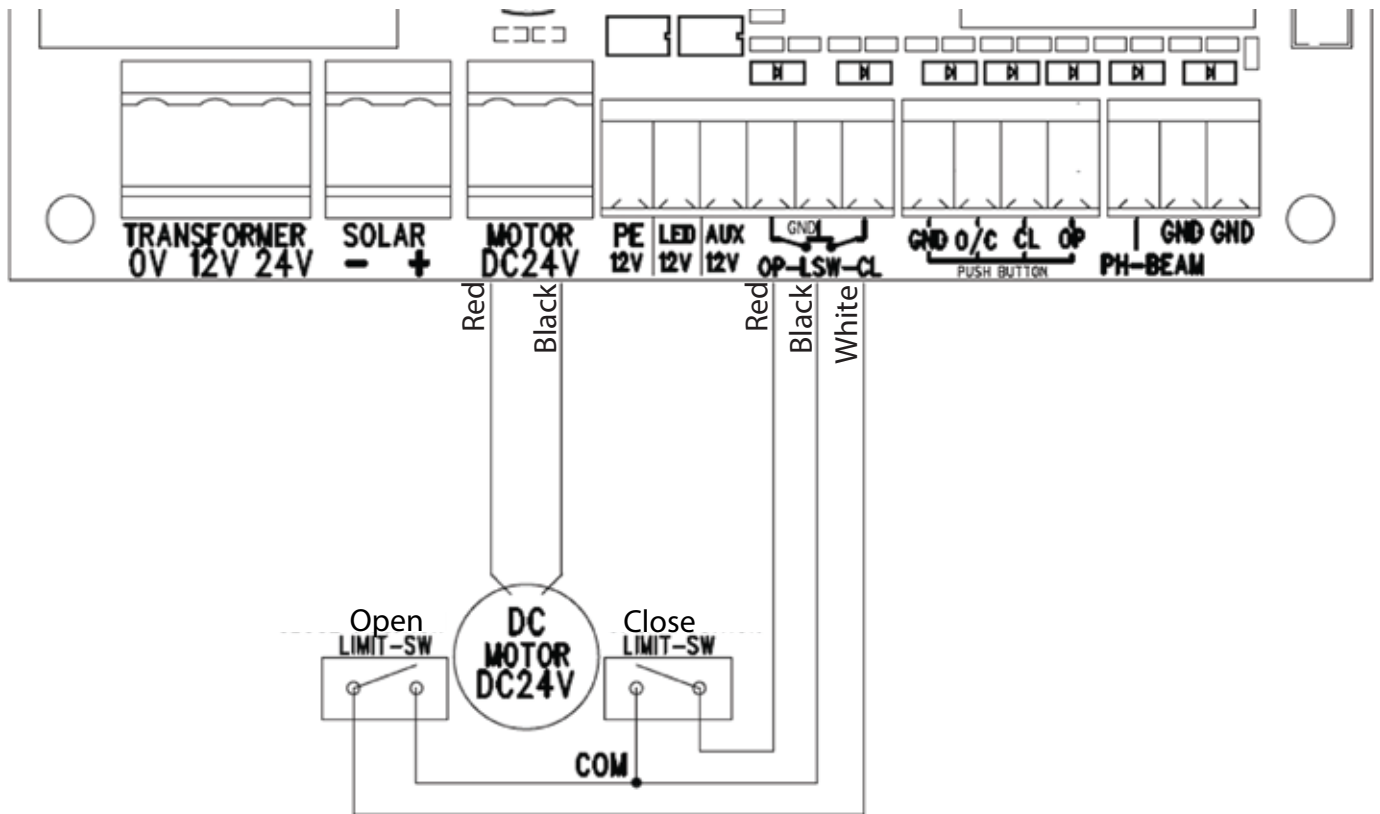

1. Connect the red cable(Motor cables) to to the first port of the MOTOR DC24V port.
2. Connect the black cable(Motor cables) to the second port of the MOTOR DC24V port.
3. Connect the red cable to OP(Limit Switch Cables).
4. Connect the black cable to LSW(Limit Switch Cables).
5. Connect the white cable to CL(Limit Switch Cables).

# Installation

## Installation Procedure

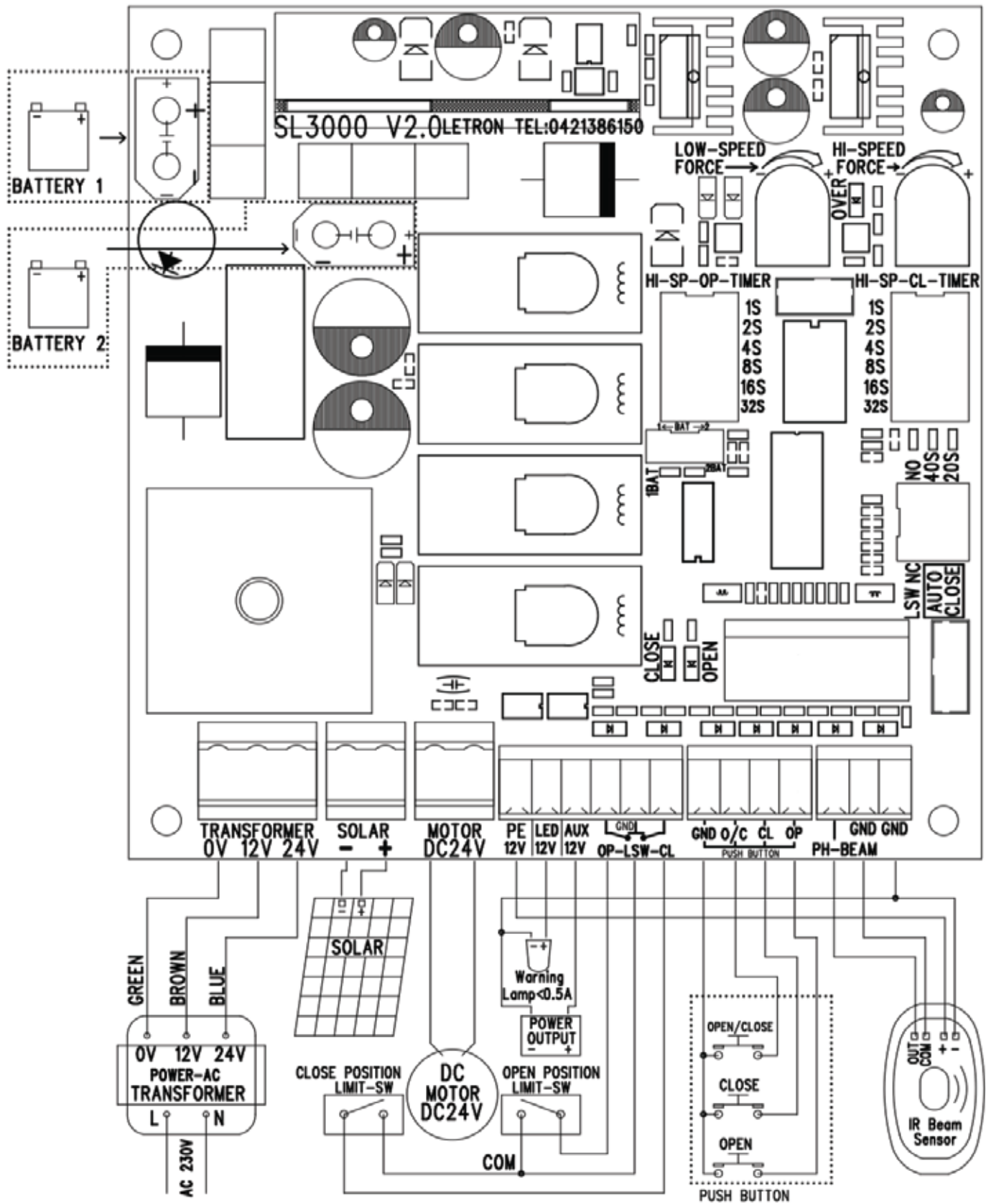

**\*IMPORTANT\* DO NOT SWITCH ON UNTIL YOU HAVE FULLY COMPLETED THE FIRST THREE STEPS SUCCESSFULLY**

# Installation

## 1. Gate and Rack Installation

1. Safely secure the Drive Motor onto a stable concrete slab/ground.
2. Mount the required lengths of the Racks to the gate.
3. Adjust the position of the racks so that the racks can be engaged correctly with the Pinion gear. Ensure that the Racks do not rest on the pinion gear and that it leaves an allowance of 2mm between the racks and pinion gear.

## 2. Installing the limit switches

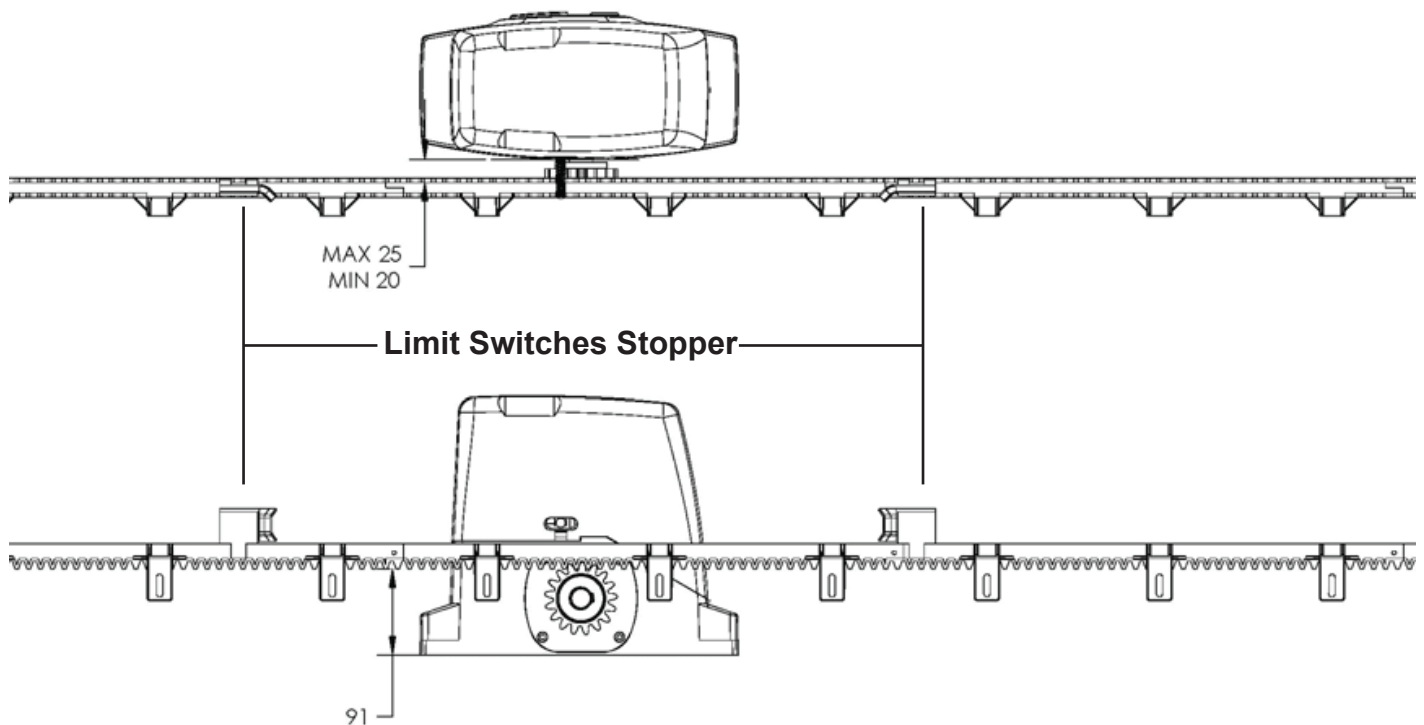

The Limit Switch Stopper is used to control the positions of the gates.

1. Screw the open and close Limit Switch Stoppers onto the gear racks. When the stoppers are secured, use the keys provided to release the gear clutch and push the sliding gates manually to predetermine the open and close positions. Then engage the gear clutch secure the gate positions. (Refer to QUICK MANUAL RELEASE OPERATION)
2. Switch on the power and start the motor to see whether the gates slide smoothly.
3. Adjust the position of the stoppers until the desired opening and closing positions of are met.

# Installation

## 3. Confirm the open and close LED

When the gate is closing the red light should be on. If the gate is opening the green light should be on

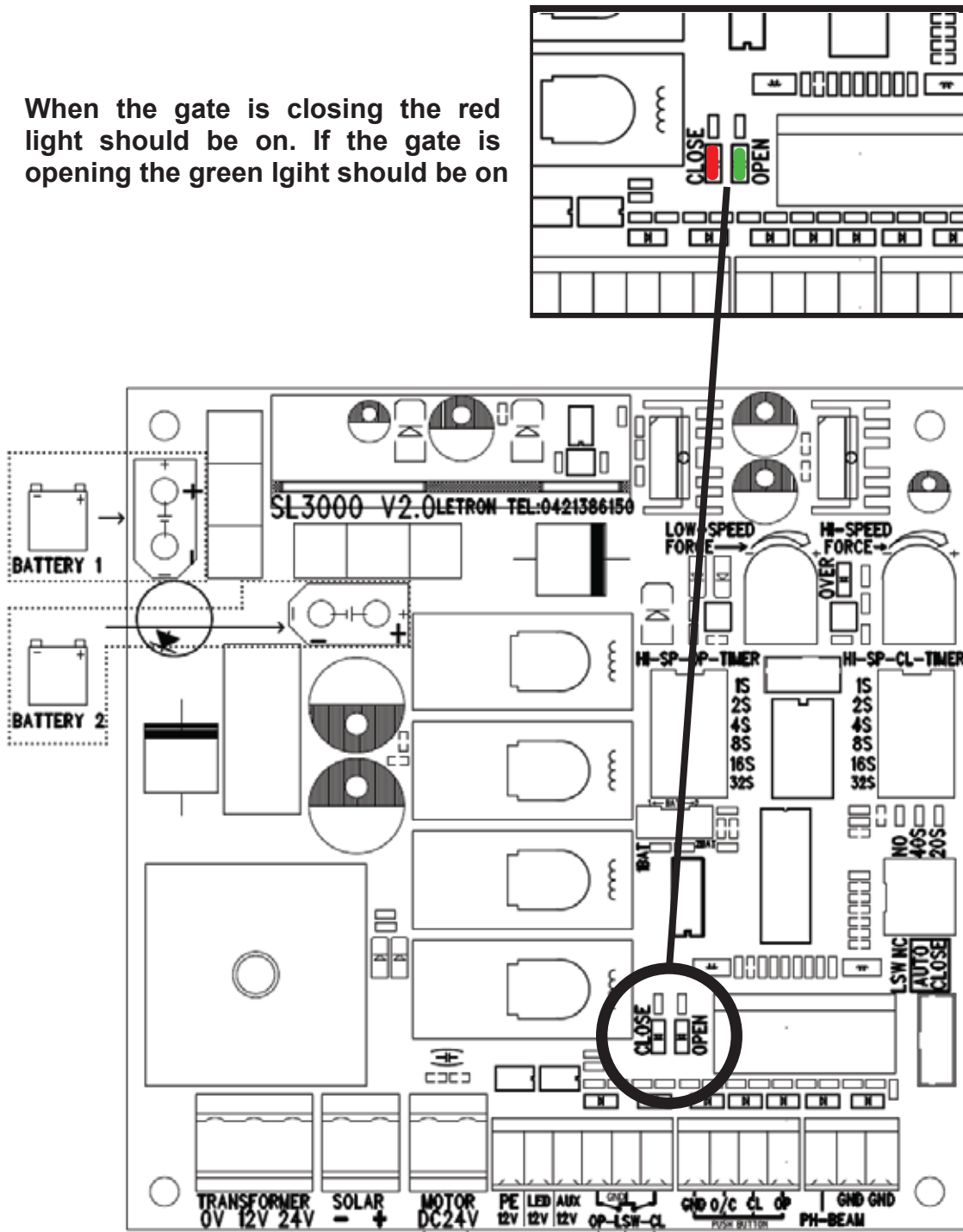

# Installation

## 4. Force Sensitivity

Sensitivity adjustment may be required to allow motor to work in all conditions as the gate opener has an obstruction sensing function.

(such as windy conditions)

When the motor is running on low speed, you will use the lower speed force to control the torque (the left dial)

When the motor is running on high speed, you will need to use the higher speed force to control the torque (the right dial)

Turn the dial clockwise to decrease the sensitivity of the torque.

The torque supplied to each motor can be adjusted independently (for situations where gate sizes or conditions vary).

Turn the dial anticlockwise to increase sensitivity. Turn dial clockwise to increase motor torque if the gates reverse due to weather variables.

When an obstruction is detected, the Gate Openers will reverse when closing or stop when opening.

Please note – Heavy Gates may not open or close fully when the Torque dial is in the minimum position. If the gates close and open itself, the force adjustment is not right. Increase the force adjustment.

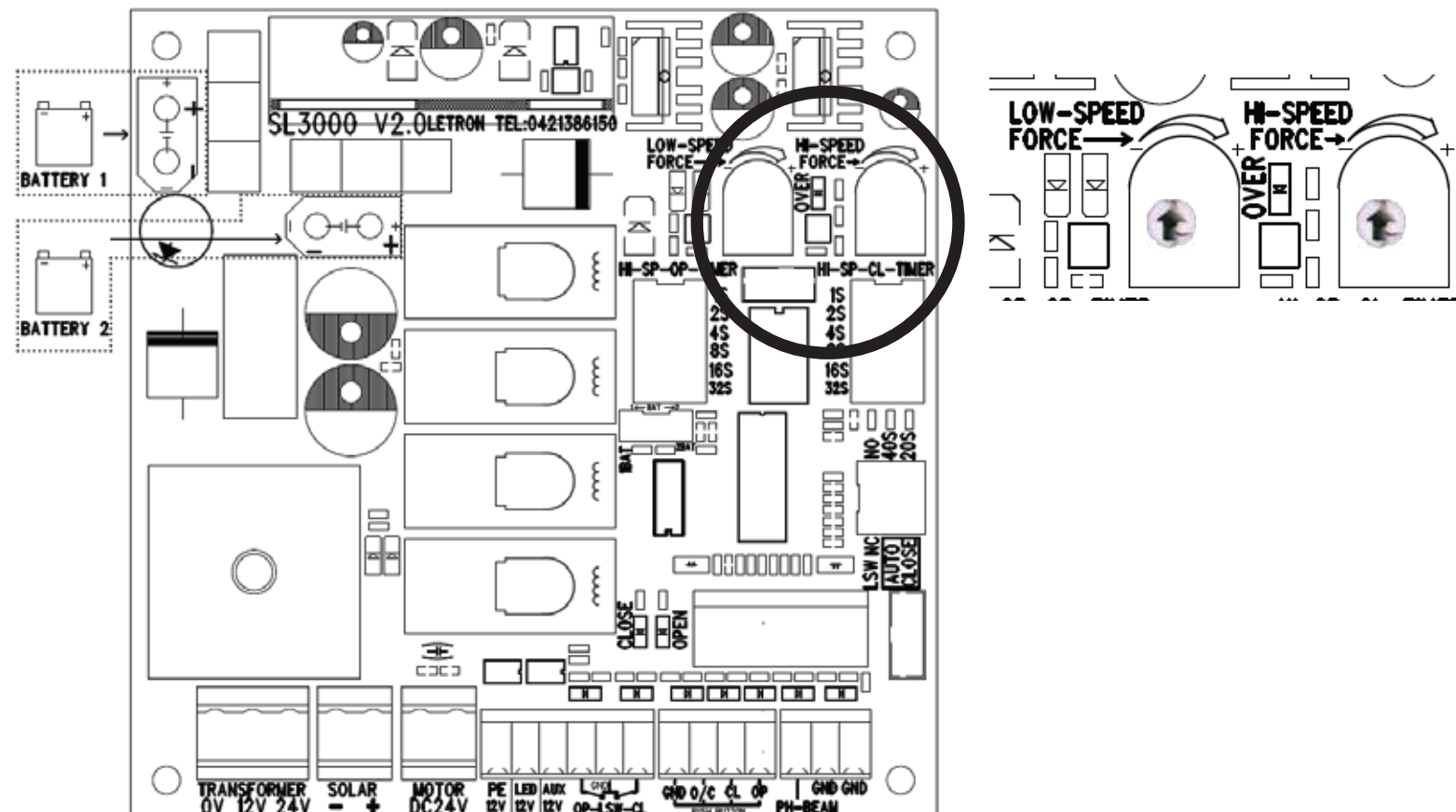

# Installation

## 5. Auto Close

**\*IMPORTANT\***



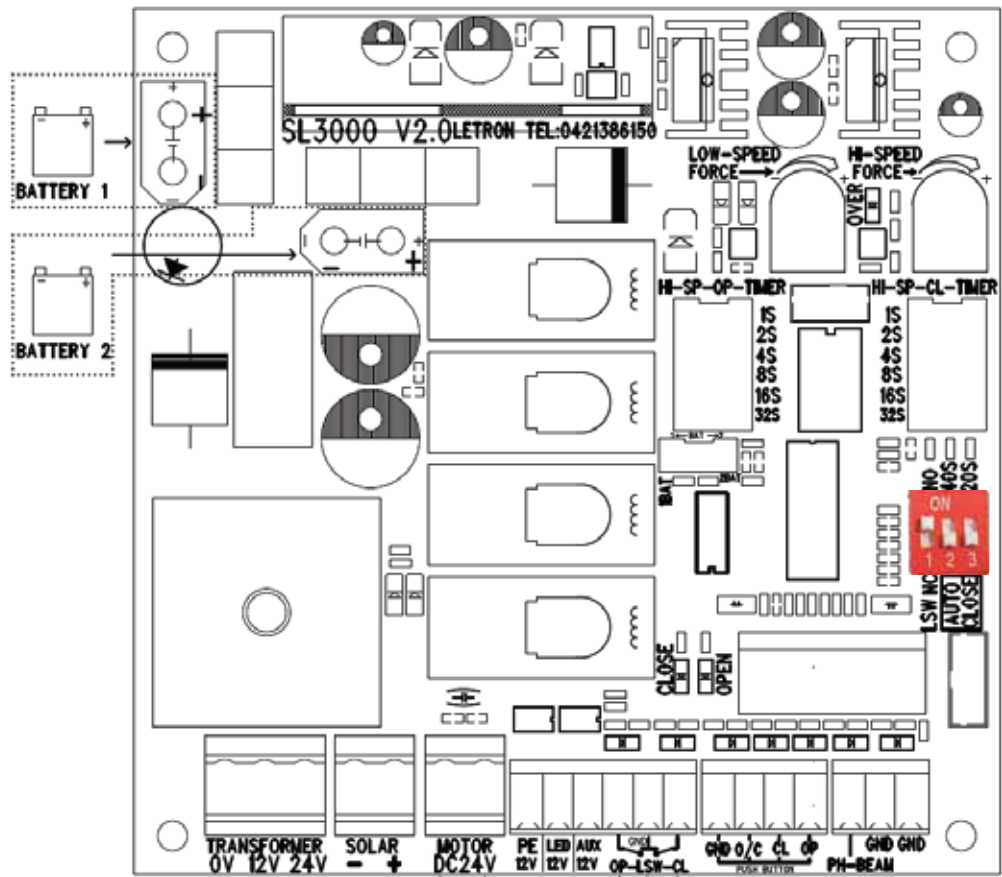

**USE OF AUTO CLOSE MUST INSTALL PHOTO ELECTRIC BEAM**



Factory default it is set to off but to have 20 seconds for auto close push number 3 switch to on.

Same thing when you want add 40 seconds just push the number 2 switch to on.

But if you want 60 seconds both 20s and 40s must be switch to on.

-  **Default:OFF**
-  **40 seconds**
-  **20 seconds**
-  **60 seconds**

# Installation

## 6. Setting up the Remote Control

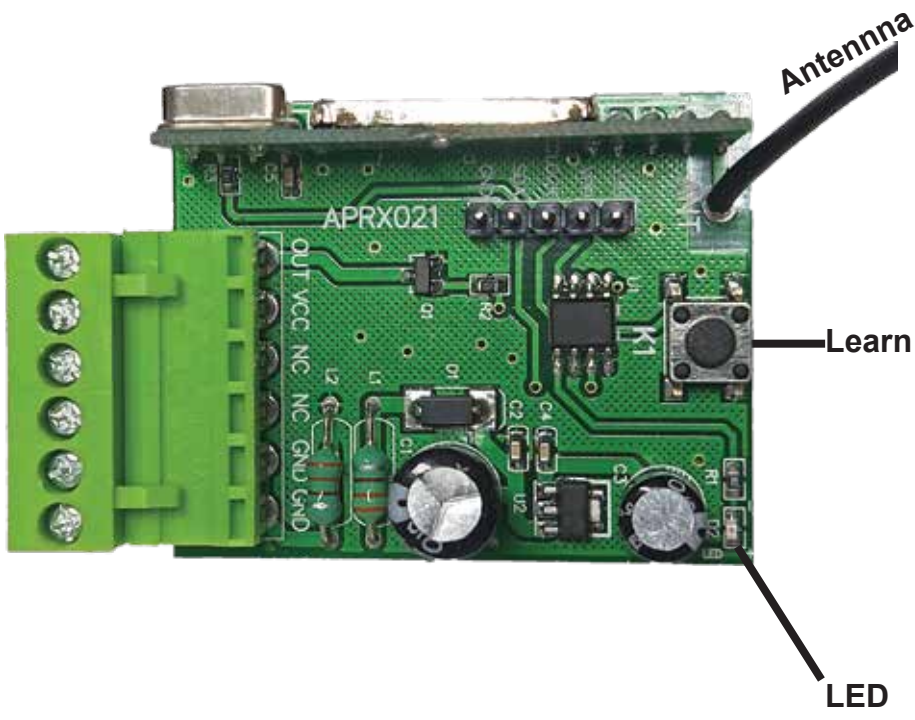

1. Press learn button once on the receiver for one second then the light should Flash
2. Press the button on your remote you want to program
3. The LED should flash once now the remote has been programmed

## 7. High speed timer setting

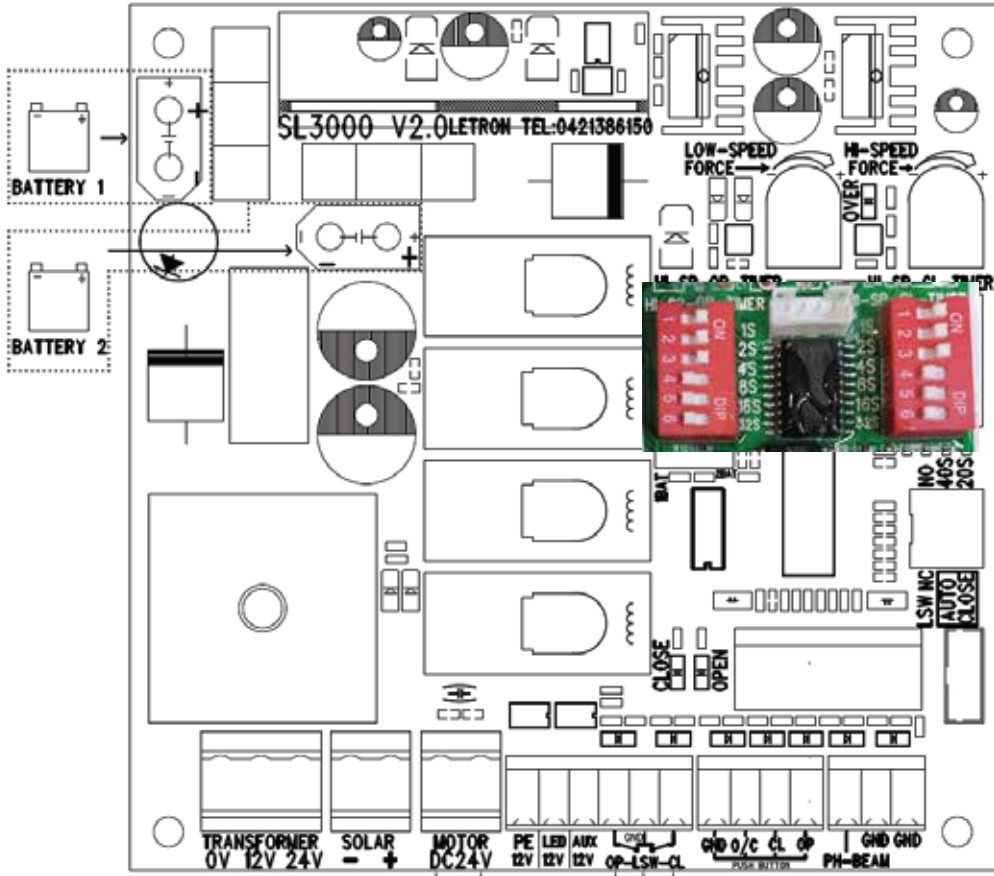

If the motor is mounted on the LEFT

Open timer is on the LEFT  
Close timer is on the RIGHT

If the motor is mounted on the RIGHT

Open timer is on the RIGHT  
Close timer is on the LEFT

Each second turn on will be the amount of time set for opening or closing.  
e.g 2s + 4s = 6s in total

## Maintenance

- All maintenance should be carried out by qualified personnel.
- Clean and lubricate any moving components.
- In case of rust, use some grease on it.
- Ensure that the slider gate is always well balanced.
- Ensure there are not binding / sticking of the gates which can falsely trigger the photo electric beam.
- Regularly test the slider gate motor to ensure that the obstruction sensor unit is operating properly.
- Spare parts can be purchased directly from us.



# Installation

## Quick Manual Release Operation

### To Unlock:

Step 1:

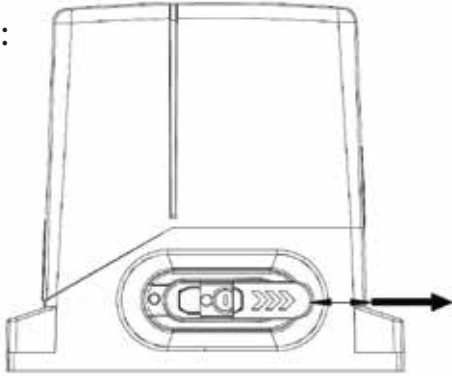

Slide the door to the right to open

Step 2:

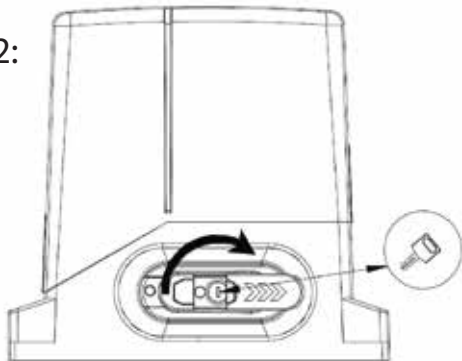

Turn with the key clock wise

Step 3:

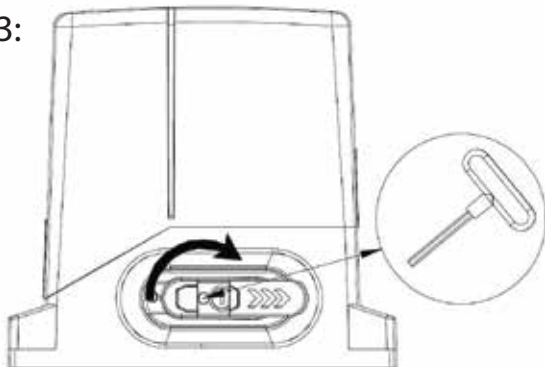

Turn with the allen key clock wise to the limit

### To Lock:

Step

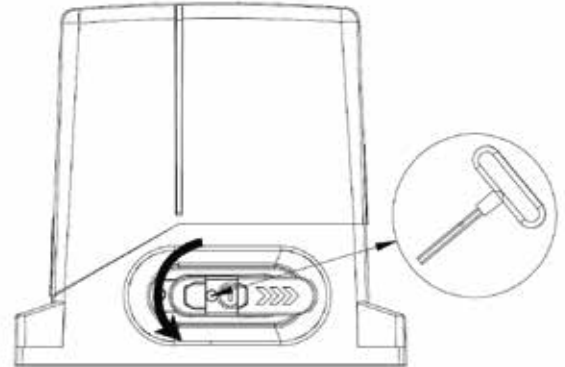

Turn with the allen key anti-clock wise to the limit

Step 2:

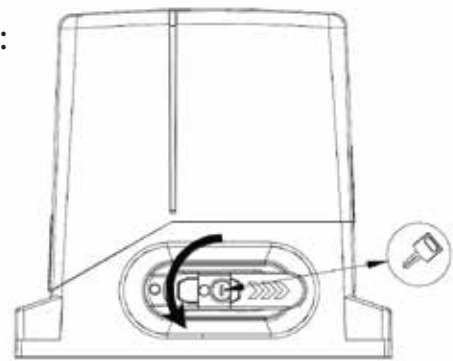

Turn with the key anti-clock wise

Step 3:

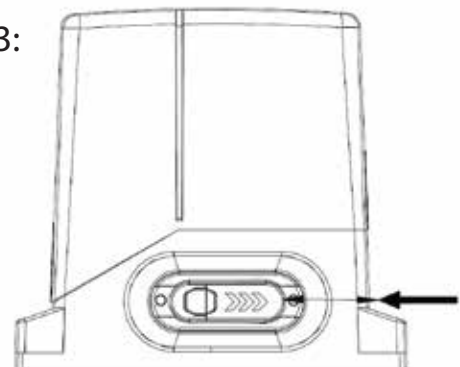

Slide the door to the left to close

## Troubleshooting

<b>Problem</b>	<b>Possible Cause</b>	<b>Solution</b>
<b>Remote control doesn't work or has too short range</b>	<b>Remote control battery may be flat.</b> <b>Remote control may not be coded to the Receiver Board.</b> <b>Receiver antenna not be fully extended.</b> <b>Radio interference may be affecting your Receiver.</b>	<b>Replace Battery Code</b> <b>Remote control Extend Aerial</b> <b>Remove any possible external interference e.g. Baby Monitor</b>
<b>The gate doesn't open or close</b>	<b>Power source may not be connected.</b> <b>Back up battery may be exhausted after prolong power failure</b>	<b>Ensure the transformer is connected to the circuited board.</b> <b>Ensure the battery is connected to the circuited board.</b>
<b>The gate re-opens or stops during operation</b>	<b>Sensitivity may be set too light (Motormay need more torque) Gate may be obstructed</b> <b>Photoelectric cells- Safety Beams( where fitted) may be dirty</b>	<b>Increase motor torque.</b> <b>Check for obstruction.</b> <b>Clean and check PE cells.</b>
<b>The gate auto opens rather than auto closes</b> <b>Open green led is on, but gate is close.</b> <b>Close red led is on but gate is open</b>	<b>Motor &amp; Limit switch may be wired reverse</b>	<b>Change motor on the circuit board &amp; re-adjust Limit switch.</b>
<b>The motor spins but the gate doesn't open</b>	<b>The manual release may not be engaged.</b>	<b>Ensure the manual release are properly engaged and tighten onto the gear.</b>

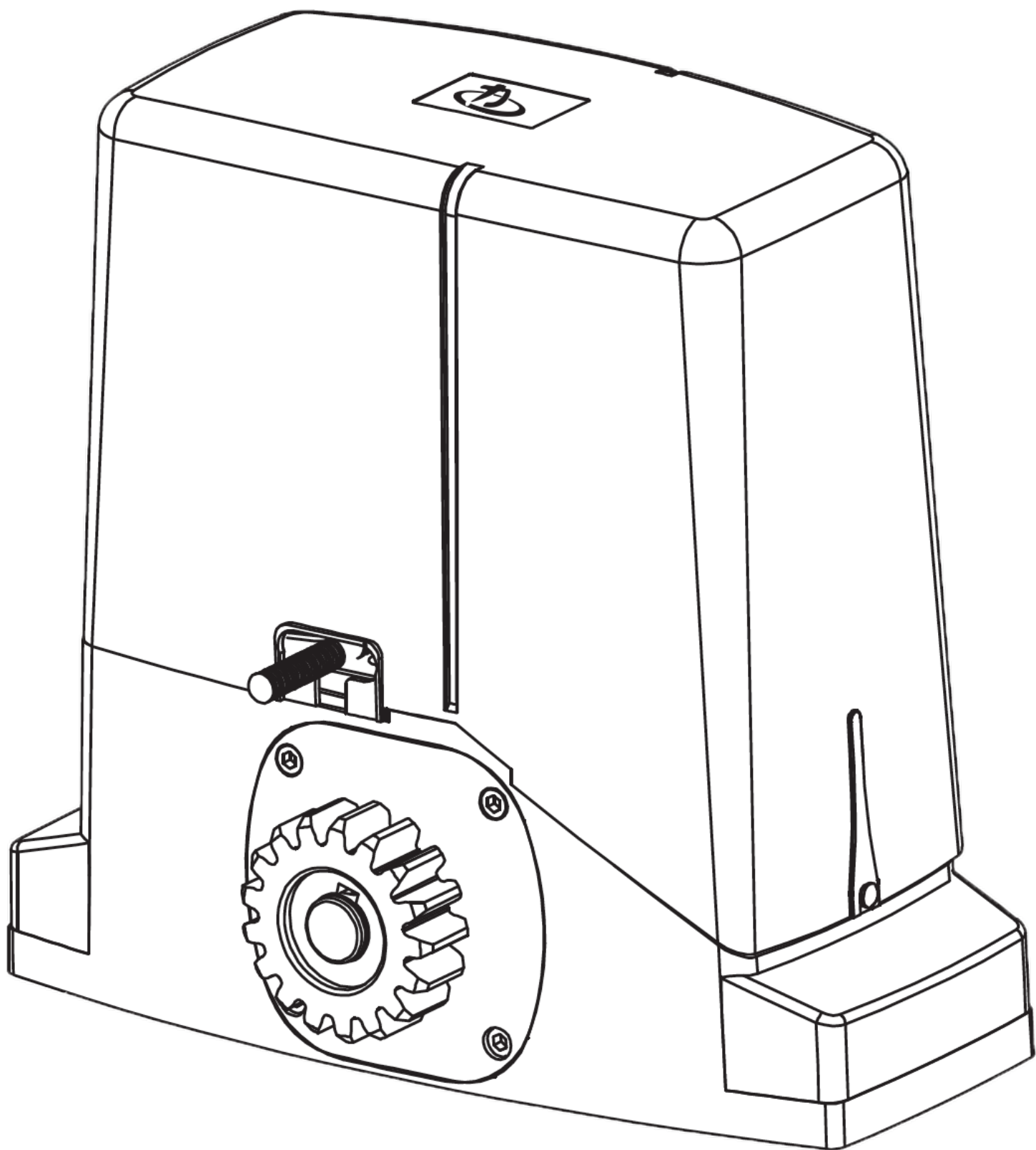



 **Letron Auto Gate (Australia) Pty Ltd**  
**63 Scoresby Road**  
**Bayswater**  
**Victoria 3153**  
**Australia**

 **Tel : (03) 8288 1119**  
 **Mob : 0421 386 150**  
 **Email : [letron@gmail.com](mailto:letron@gmail.com)**  
 **[www.letron.com.au](http://www.letron.com.au)**