

ELEVO

- IT Istruzioni ed avvertenze per l'installazione e l'uso
- EN Instructions and warnings for installation and use
- FR Instructions et avertissements pour l'installation et l'utilisation
- DE Anweisungen und Warnungen zur Installation und Benutzung
- ES Instrucciones y advertencias para la instalación y el uso
- PT Instruções para instalação e programação
- PL Instrukcje i ostrzeżenia dotyczące instalacji i użytkowania
- CZ Instrukce pro instalaci a použití



Contents

| | | | |
|---|-----------|---|-----------|
| 1. General warnings | 26 | 13. AUX output programming | 43 |
| 1.1 - Safety warnings | 26 | 13.1 - Selection of device connected to “Lock/AUX” output | 43 |
| 1.2 - Installation warnings | 26 | 13.2 - Selection of the type of devices connected to “S1 Edge” | 44 |
| 1.3 - Scrappin the product | 26 | | |
| 1.4 - Disposing of exhausted battery | 26 | 14. Other functions | 45 |
| | | 14.1 - Activating/deactivating the control unit protection device | 45 |
| 2. Product description | 27 | 15. F.A.Q. | 46 |
| 2.1 - Operating limits | 27 | | |
| 2.2 - Typical system | 27 | 16. Technical specifications | 47 |
| 2.3 - List of cables | 27 | | |
| 2.4 - Main features of the control unit | 28 | 17. CE Declaration of conformity | 48 |
| 2.3 - Technical features of the control unit | 28 | | |
| 3. Installation | 29 | | |
| 3.1 - Preliminary checks | 29 | | |
| 3.2 - Fitting ELEVO | 29 | | |
| 3.2.1 - Assembly of guide supplied GRO33 | 29 | | |
| 3.2.2 - Assembly of guide supplied GRO13 | 29 | | |
| 3.2.3 - Fitting the gearmotor to the guide | 31 | | |
| 3.2.4 - Mounting the gearmotor to the ceiling | 31 | | |
| 3.3 - Installation of other devices | 32 | | |
| 3.4 - Electrical connections | 32 | | |
| 3.5 - Description of the electrical connections | 33 | | |
| 3.6 - Connecting ELEVO to the mains | 33 | | |
| 3.7 - Control unit | 33 | | |
| 4. Control unit setting | 34 | | |
| 4.1 - Dip-switch adjustment | 34 | | |
| 4.2 - Knob adjustment | 34 | | |
| 5. Transmitter (remote control unit) programming | 35 | | |
| 5.1 - Start button programming | 35 | | |
| 5.2 - Programming of the button linked to the “Lock/AUX” output | 35 | | |
| 5.3 - Programming of the button linked to the on-board courtesy light | 35 | | |
| 5.4 - Deleting all memorised transmitter | 36 | | |
| 5.5 - Deleting a single transmitter | 36 | | |
| 5.6 - Remote (tools free) transmitter programming | 36 | | |
| 6. Programming the door path | 37 | | |
| 6.1 - Basic programming of the automation’s movement | 37 | | |
| 6.2 - Advanced programming of the automation’s movement | 38 | | |
| 7. Testing and commissioning | 38 | | |
| 8. LED indication | 39 | | |
| 8.1 - Input status indication LEDs | 39 | | |
| 8.2 - Error status LED | 39 | | |
| 9. RESET procedure | 39 | | |
| 10. Devices connectable to the control unit | 40 | | |
| 10.1 - Warning light | 40 | | |
| 10.2 - Aux contact | 40 | | |
| 10.3 - Safety device | 40 | | |
| 10.4 - Accessories power supply | 41 | | |
| 10.5 - Wired commands | 41 | | |
| 10.6 - Antenna | 41 | | |
| 11. Advanced programming | 42 | | |
| 12. Backjump adjustment | 42 | | |

1. General warnings

1.1 - Safety warnings



CAUTION!

- **This manual contains important safety instructions and warnings. Incorrect installation could lead to serious injury. Before starting, please read all sections of the manual carefully. If you are unsure about something, stop installation immediately and contact KING-gates Customer Service for assistance.**

- **Important: please retain this manual for future maintenance work and product disposal.**

1.2 - Installation warnings

- Before beginning the installation procedure, check that this product is suitable for the intended use (see sections 3.1 and 3.2). If unsuitable, do NOT proceed with installation.

The contents of this manual refer to an installation like the one shown in **fig. 1**.

- Taking into account the hazards which could occur during installation and product operation, the automation system should be installed according to the following procedure:

- Ensure there is a system device which is a means of disconnection from the supply mains. This device must have a contact separation in all poles which ensures full disconnection under overvoltage category III conditions.

- All installation and maintenance operations must be carried out with the automation system switched off and the power supply disconnected. If the disconnection device is not visible from where the automation system has been installed, a sign must be attached to it before attempting any work. The sign should read: "CAUTION! MAINTENANCE WORK IN PROGRESS".

- The product must be connected to a power supply line equipped with safety grounding system.

- Take care not to crush, bang, drop or spill any kind of liquid on the automation system during installation. Do not keep the product close to sources of heat or open flames. Doing so may damage it, corrupt it or lead to hazardous situations. If this were to happen, stop installation immediately and contact KING-gates Customer Service.

- Do not make alterations to the product in any way. Improper use can only lead to malfunctions. The manufacturer declines all liability for damage caused by arbitrary modifications to the product.

- This product is not intended for use by people (including children) with reduced physical, sensory or mental capabilities or who lack experience and knowledge, unless they have been given supervision or instruction concerning the use of the product by a person responsible for their safety.

- The product is not intended as an intruder protection system. Additional devices must be installed alongside the automation system to guarantee effective protection.

- Do not allow children to play with the fixed control devices. Keep remote control devices out of their reach as well.

- The automation system must not be used until it has been commissioned as described in chapter 5 ("Testing and commissioning").

- The packing materials of the product must be disposed of in compliance with local regulations.

1.3 - Scrapping the product

This product is made of various types of materials, some of which can be recycled while others must be scrapped. Seek information on the recycling and disposal systems envisaged by local regulations in your area for this product category.

WARNING! - Some parts of the product may contain polluting or hazardous substances which, if released into the environment, constitute serious environmental and health risks.

As indicated by the adjacent symbol, the product may not be disposed of together with domestic waste. Sort the materials for disposal, according to the methods envisaged by current legislation in your area, or return the product to the retailer when purchasing an equivalent product.



WARNING! - Local regulations may envisage the application of heavy fines in the event of improper disposal of this product.

1.4 - Disposing of exhausted battery

Discharged battery contain pollutant substances and therefore must never be disposed of as normal waste. Dispose of them in observance of local sorted waste disposal regulations.

2. Product description

ELEVO is a gearmotor designed for the automation of sectional and overhead doors.

ELEVO operates using electric power. In the event of a power failure, the gearmotor can be released in order to move the door manually.

NE

2.1 - Operating limits

Chapter 16 (“Technical specifications”) provides the data needed to determine whether the product is suitable for the intended application. Its structural characteristics make it suitable for use on sectional doors within the limits shown in **tables 1, 2 and 3**.

| Model: | SECTIONAL door | | Overhead door | |
|------------|----------------|----------------------------|---------------|-----------------------------|
| ELEVO 620 | Height: 2.4 m | Surface: 10 m ² | Height: 2.4 m | Surface: 8.5 m ² |
| ELEVO 1000 | Height: 2.4 m | Surface: 16 m ² | Height: 2.4 m | Surface: 11 m ² |

The effective suitability of ELEVO for automating a specific door depends on the degree of door leaf balancing, guide friction and other aspects, including occasional phenomena such as wind pressure or the presence of ice, which could obstruct leaf movement.

To establish effective conditions, the force required to move the leaf throughout its stroke must be measured to ensure that this value does not exceed the “nominal torque” specified in section 9 (“Technical specifications”).

To avoid overheating, the control unit has a limiter that is based on the motor operation and duration of cycles, and trips when the maximum limit is exceeded.

N.B.: 1 kg = 9.81 N, for example, 500 N = 51 kg

2.2 - Typical system

Fig. 1 shows a typical system for automating a sectional door.

a ELEVO

b Photocells

c Main edge

d Flashing light with incorporated aerial

e Key-operated selector switch

2.3 - List of cables

Table 2 shows the specifications of the cables needed to connect up the various devices.

The cables used must be suitable for the type of installation. For example, an H03VV-F type cable is recommended for indoor applications.

| Connection | Cable type | Maximum length allowed |
|------------------------------|---|----------------------------------|
| Flashing light with aerial | 1 2x0.5 mm ² cable | 20 m |
| | 1 RG58 type shielded cable | 20 m (recommended less than 5 m) |
| Photocells | 1 2x0.25 mm ² cable for TX | 30 m |
| | 1 4x0.25 mm ² cable for TX | 30 m |
| Key-operated selector switch | 2 2x0.5 mm ² cables (note 1) | 50 m |

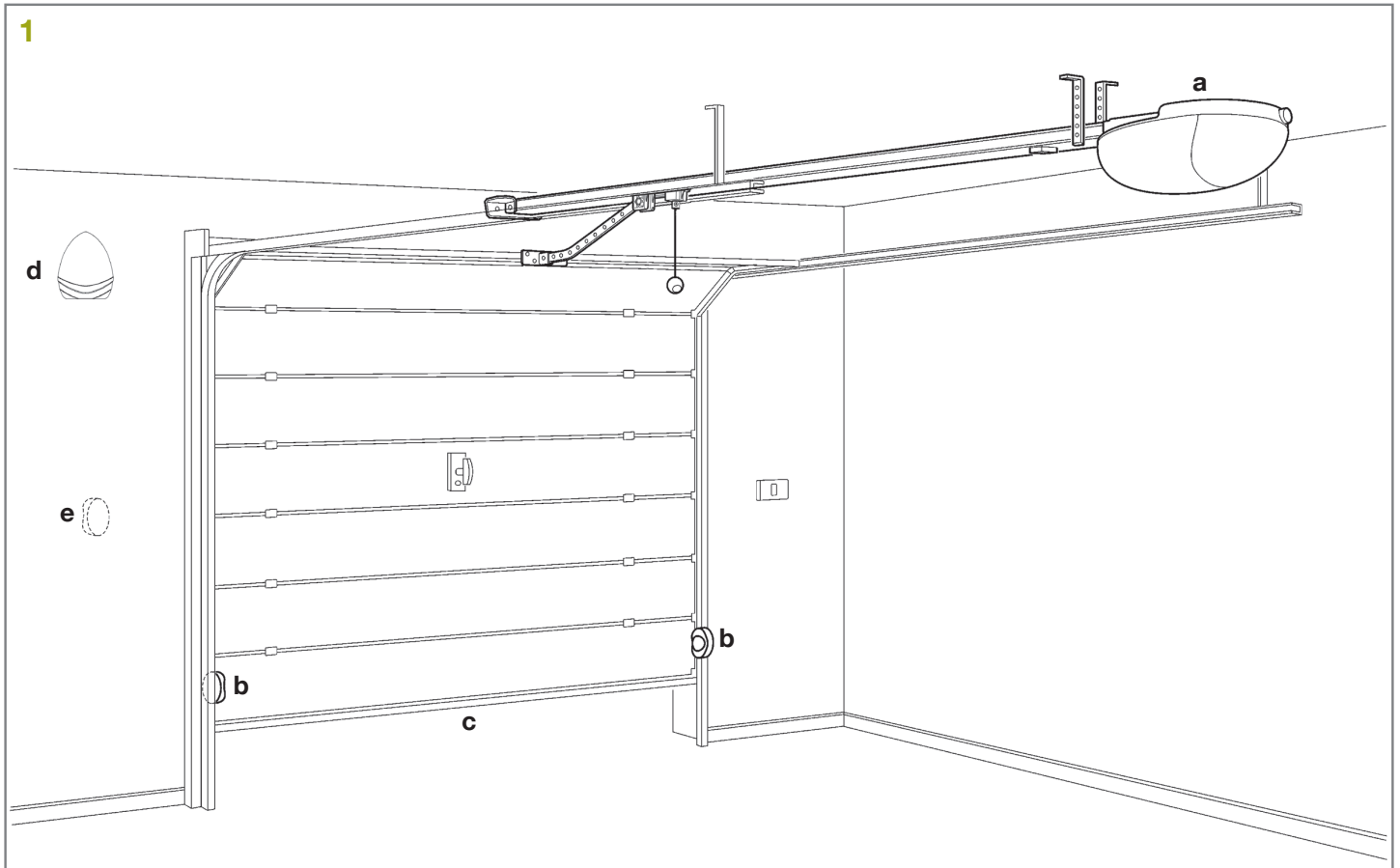

Note 1: a single 4x0.5mm² cable can be used instead of two 2x0.5mm² cables.



2.4 - Main features of the control unit

- Automated access command for 1 24V motor.
- Flasher control with/without integrated intermittency function (Paragraph 10.3).
- Integrated management for electric locks 24V max. 15VA (Paragraph 10.4).
This output can also be used to control courtesy lights (Paragraph 13).
- Inputs for start, stop opening wired commands, (Paragraph 10.7).
- Double input for safety devices: "S2 Photo" during opening and closing and "S1 Edge" during opening (Paragraph 10.5).
- Possibility of powering 24V  accessories (Paragraph 10.6).
- Input for external antenna that can be used for increasing the range of the transmitters (Paragraph 10.8).
- Pause time for automatic re-closing adjustable to between 0 and 180 sec. with knob (Paragraph 4.2).
- Obstacle sensitivity adjustment with knob (Paragraph 4.2).
- Motor force adjustment with knob (Paragraph 4.2).
- Incorporated radio receiver (433.92MHz), compatible with King-Gates rolling transmitters.
- 7 indication LEDs (Paragraph 8).
- Slow-speed opening and closing (customizable through dedicated programming).

2.5 - Technical features of the control unit

| | |
|--|--|
| Mains power supply* | 230 Vac $\pm 10\%$, 50-60 Hz |
| Motor power supply | 24V  110W |
| Warning light power supply | 24V max 10W |
| Accessories' power supply (photocells...) | 24V  max 10 W |
| Radio receiver frequency | 433.920 MHz |
| Storable remote controls | 170 |
| Radio antenna input | RG58 |
| Operating temperature | -20 \div 55 °C |

3. Installation

The installation of ELEVO must be carried out by qualified personnel in compliance with current legislation, standards and regulations, and the directions provided in this manual.

3.1 - Preliminary checks

Before proceeding with the installation of ELEVO you must:

- Verify and ensure after installation that no door parts obstruct public roadways or pavements.
- Check that all the materials are in excellent condition, suitable for use and that they conform to the standards currently in force.
- Make sure that the structure of the gate is suitable for automation.
- Make sure that the force and dimensions of the door fall within the specified operating limits provided in chapter 2.1 (“Operating limits”).
- Check that the static friction (that is, the force required to start the movement of the leaf) is less than half the “maximum torque”, and that the dynamic friction (that is, the force required to keep the leaf in movement) is less than half the “nominal torque”. Compare the resulting values with those specified in section 16 (“Technical specifications”). The manufacturer recommends a 50% margin on the force, as unfavourable climatic conditions may cause an increase in the friction.
- Make sure that there are no points of greater friction in the opening or closing travel of the door.
- Make sure that the mechanical stops are sturdy enough, and that there is no danger of the door derailing.
- Make sure that the door is well balanced: it must not move by itself when left stationary in any position.
- Make sure that the mounting positions of the various devices (photo-cells, keys, etc.) are protected from impact and that the mounting surfaces are sufficiently sturdy.
- Make sure that the minimum and maximum clearances specified in **fig. 2** and **3** are observed.

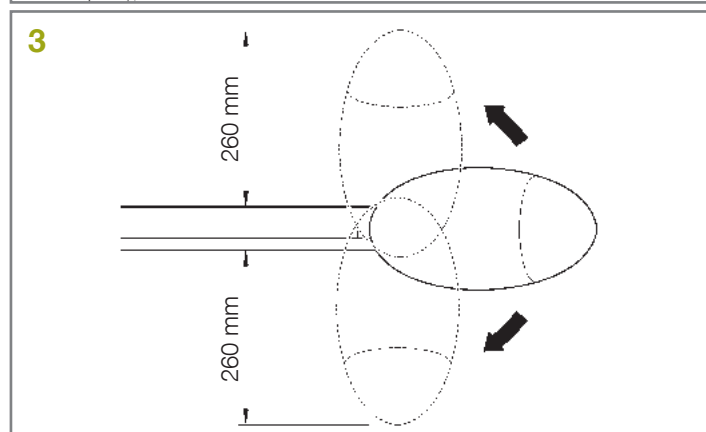
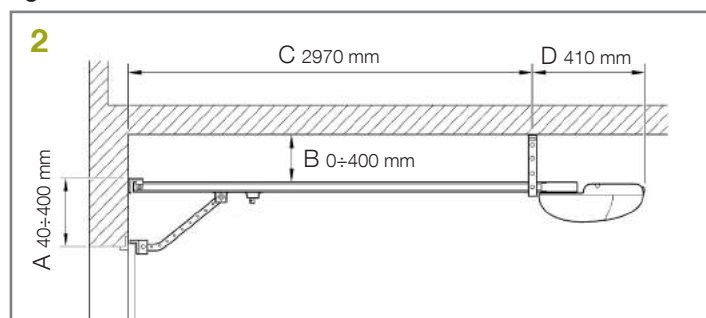

- Check and ensure that the manual release is fitted at a maximum height of 1.8 m.

- Components must never be immersed in water or other liquids.
- Keep all ELEVO components away from heat sources and open flames; these could damage the components and cause malfunctions, fire or dangerous situations.
- If the door includes an access door, make sure that it does not obstruct normal travel. Fit a suitable interlock system if necessary.
- Only insert the ELEVO plug into sockets equipped with a safety grounding system.
- The socket must be protected by suitable magneto-thermal and differential switches.

3.2 - Fitting ELEVO

Installation of the ELEVO gearmotor comprises 3 stages:

- Assembly of GRO33 and GRO13 guides (see sections 3.2.1 and 3.2.2).
- Mounting the gearmotor to the guide (see section 3.2.3).

3.2.1 - Assembly of guide supplied GRO33

The guide that is supplied with GRO33 must be assembled as follows:

- 01.** Referring to **fig. 4**, remove the belt tensioner device (**4a**); insert one end of the belt into the pulley (**4b**); reintroduce the belt tensioner device into the guide (**4c**).
- 02.** Pass the same end of the belt through the head [A], as in **fig. 5**. NB - Make sure that the belt is correctly positioned: it must be with the teeth facing inwards, straight and without twists.
- 03.** Turn the lower section of the carriage so that the grooves correspond with the two ends of the belt, as in **fig. 6**.
- 04.** Place both ends of the belt into all the shaped slots of the lower carriage [B]. Secure the ends of the belt with the 2 screws (V4.2x9.5) and 2 washers (R05), as in **fig. 7**.
- 05.** Fix the belt guide [C] to the upper carriage [D] with the V6x18 screw and related M6 nut, as in **fig. 8**.
- 06.** Insert the upper carriage [D] into the lower carriage [B] and place the entire carriage assembly inside the guide, as in **fig. 9**.
- 07.** Hammer the three pieces of the guide into place inside the connection brackets [E], as in **fig. 10** and **11**. **Important** – the guides must slide into the brackets until they click into position.
- 08.** Carefully position the belt into the guide, making sure that it is not twisted.
- 09.** Push the head [A] into the free end of the guide using significant force, as in **fig. 12**.
- 10.** Finally, tension the belt with the adjustment screw [F] of the belt tensioner device, as in **fig. 13**.

⚠ CAUTION! the gearmotor could break if the belt is TOO taut, and it could cause unpleasant noise if it is TOO slack.

3.2.2 - Assembly of guide supplied GRO13

The GRO13 guide is already assembled. All you have to do is tensioning the belt using the M8 nut [F] (**fig. 13**) until it is sufficiently taut.

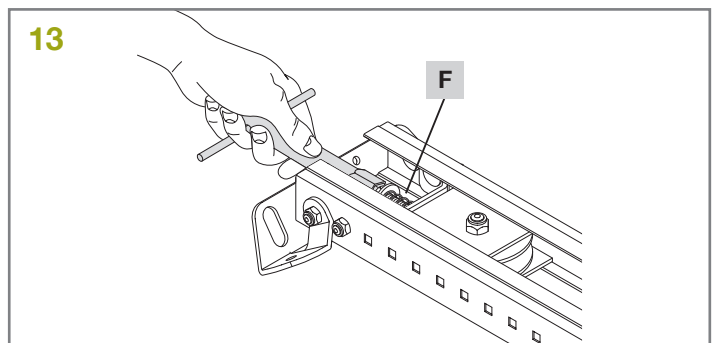
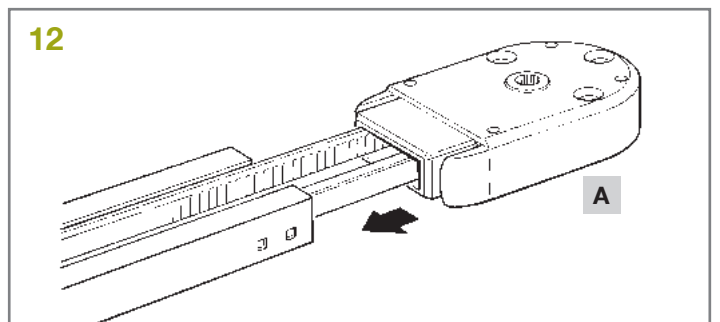
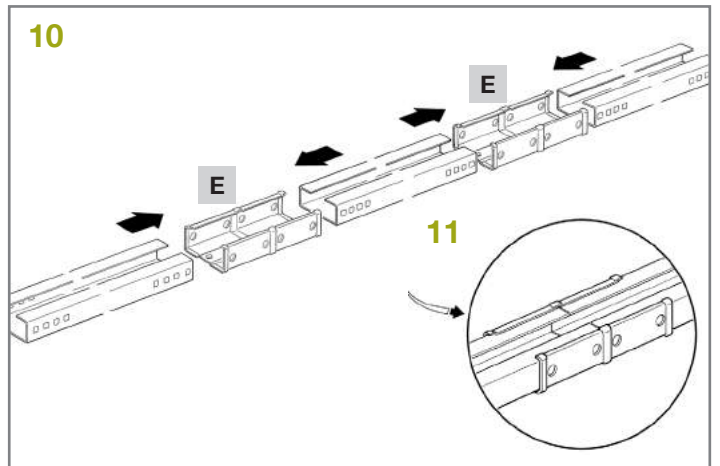
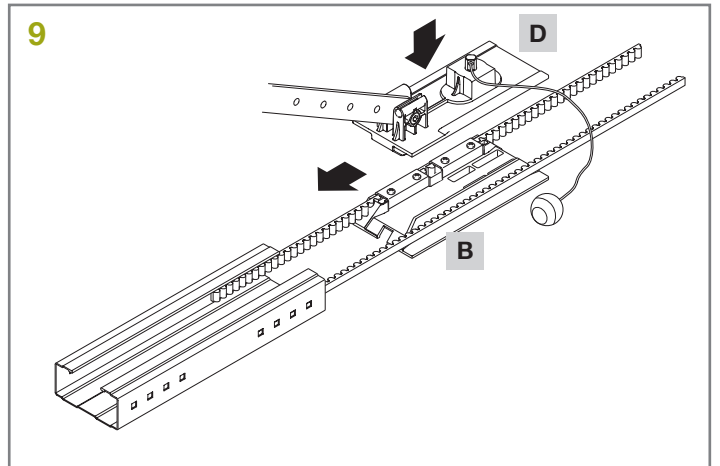
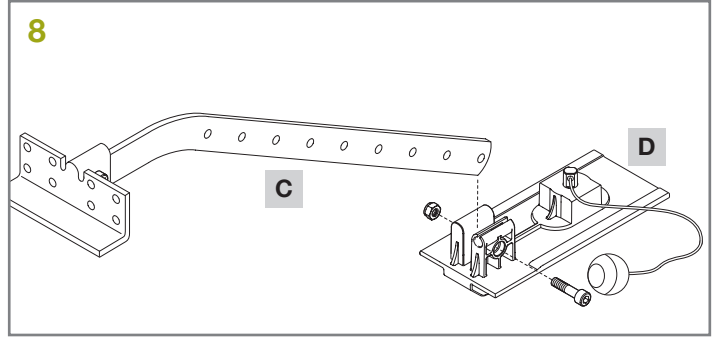
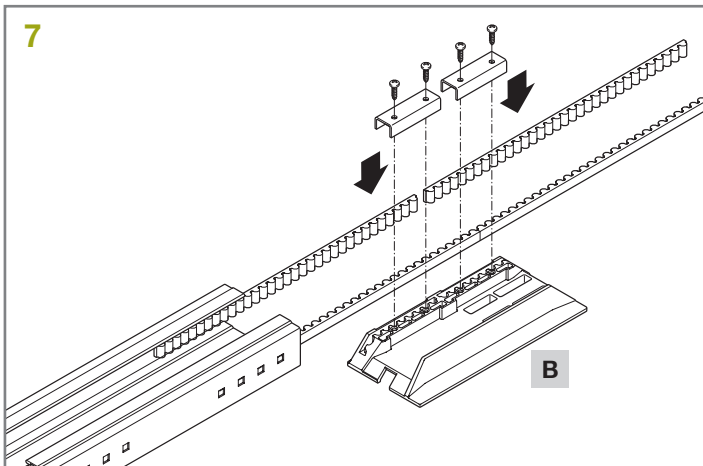
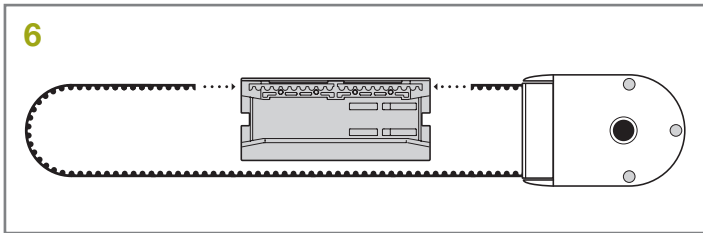
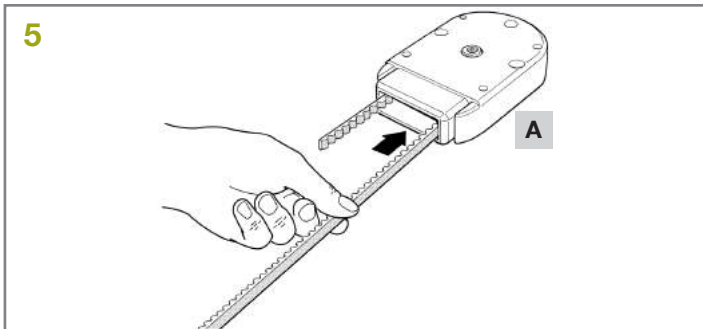
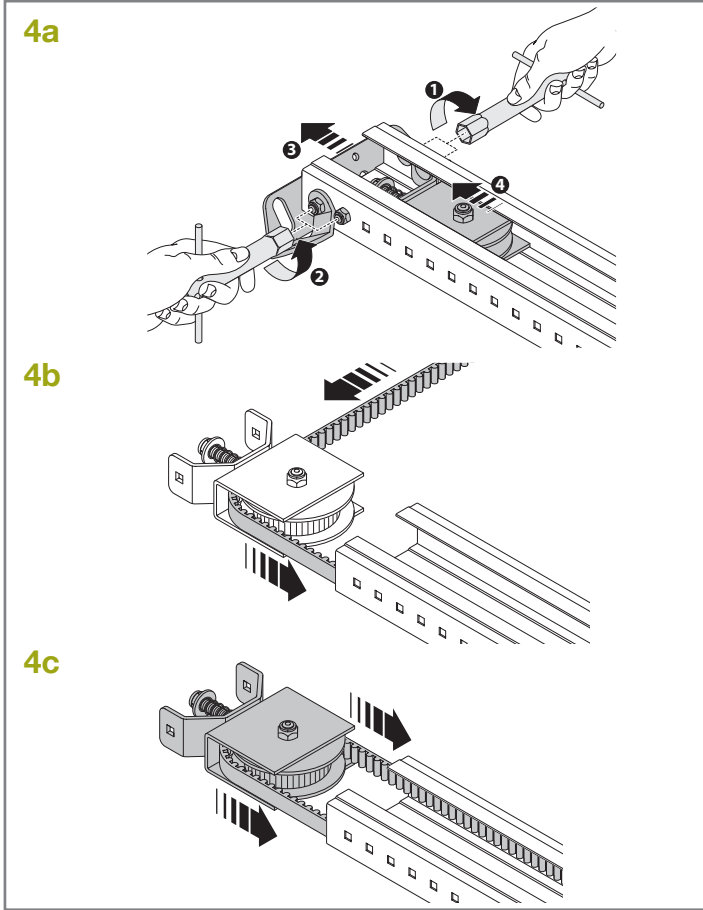

3.2.3 - Fitting the gearmotor to the guide

01. Fit the ELEVO gearmotor output shaft to the guide head [A] and secure using 4 M6.3x38 screws [G] (fig. 14). The gear motor rotates and can be positioned in three different ways (fig. 3).

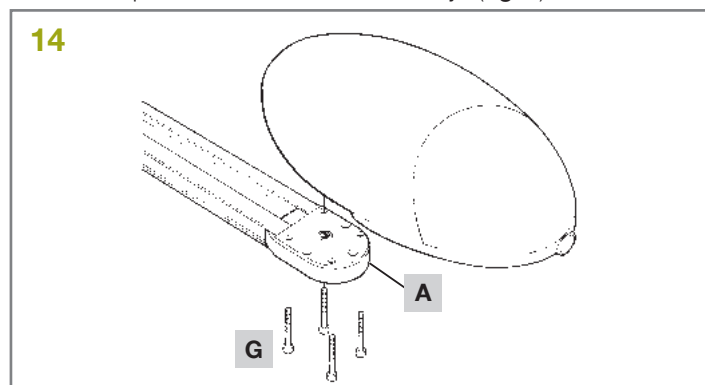

3.2.4 - Mounting the gearmotor to the ceiling

01. On the basis of distances A, B and C in fig. 2 and 3, trace the two fixing points of the front guide bracket at the centre of the door. On the basis of the type of support surface, the front bracket can be fixed with rivets, plugs or screws (fig. 15). If distances A, B and C (fig. 2 and 3) are sufficient, the bracket can be fixed directly onto the ceiling.

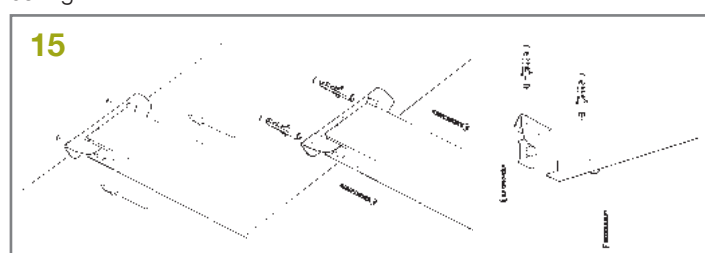

02. After drilling the holes in the relative points, leaving the gearmotor on the ground, lift the guide from the front section and secure using two screws, plugs or rivets, according to the installation surface.

03. Secure the brackets [H] using the screws [I] and nuts [L], selecting the hole most suited to ensure distance B, as shown in (fig. 16)

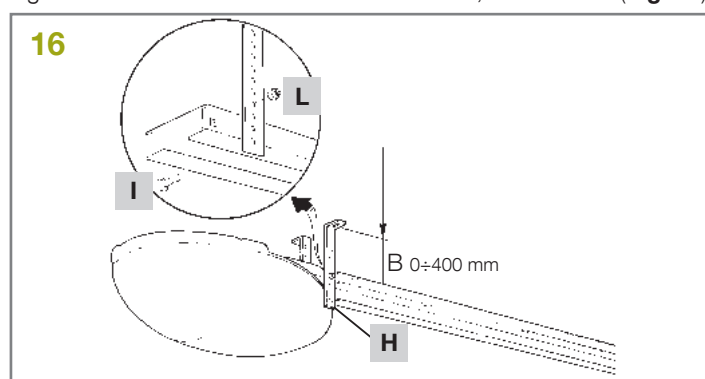

04. Using a ladder, lift the gearmotor until the brackets are touching the ceiling. Trace the drilling points and then return the gearmotor to the ground.

05. Drill at the outlined points and then, using a ladder, lift the gearmotor until the brackets are placed against the drilled holes (fig. 17) and secure using screws and plugs suited to the support surface (fig. 18).

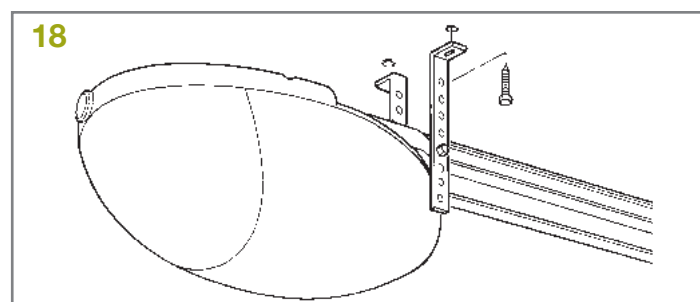
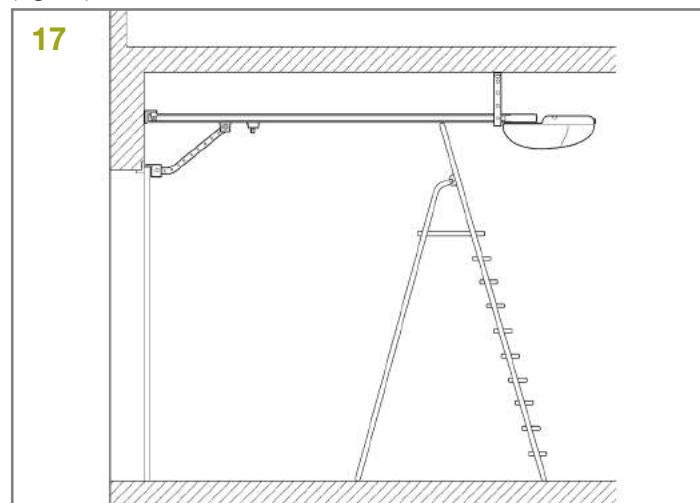

06. Ensure that the guide is perfectly horizontal, then cut off the excess section of the brackets with a saw (fig. 19).

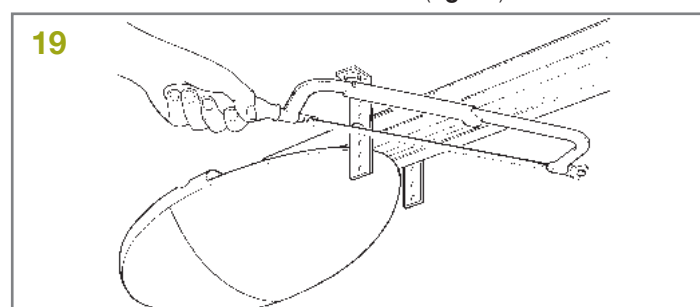

07. With the door closed, pull the cord to release carriage [M] from the guide (fig. 20).

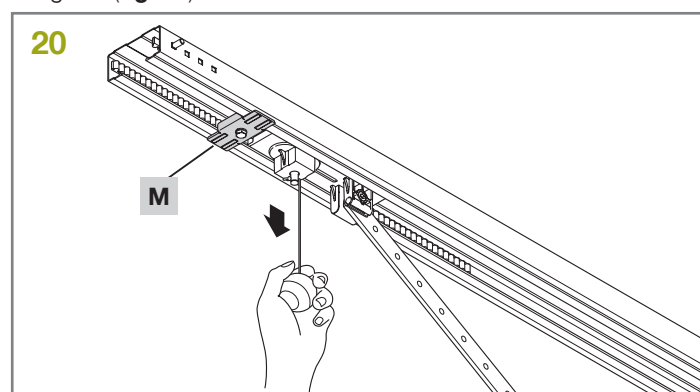

08. Slide the carriage until the leaf connecting bracket [N] (fig. 21) on the upper edge of the door is perfectly perpendicular to the guide [O].

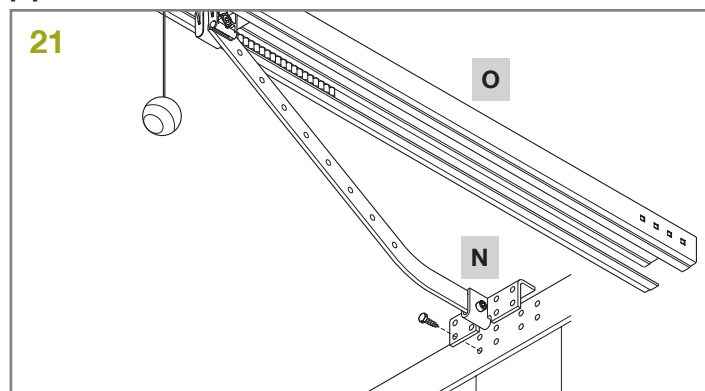

09. Then secure the leaf connecting bracket [N] with rivets or screws (fig. 21). Use screws or rivets suited to the leaf material, and ensure that they are able to withstand the maximum force required for leaf opening and closing.

10. Loosen the screws of the two mechanical stops, then move the front mechanical stop [P] in front of the carriage (fig. 22).

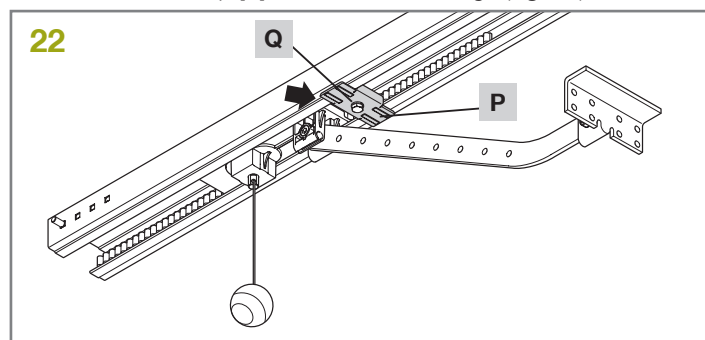

11. Push the carriage in the closing direction and, on reaching the position, tighten the screw [Q] fully down.

12. Manually open the door to the required opening position, move the rear mechanical stop [R] next to the carriage (fig. 23) and tighten the screw [Q] fully down. **Important!** - Make sure the release cord can be pulled below a height of 1.8 m.

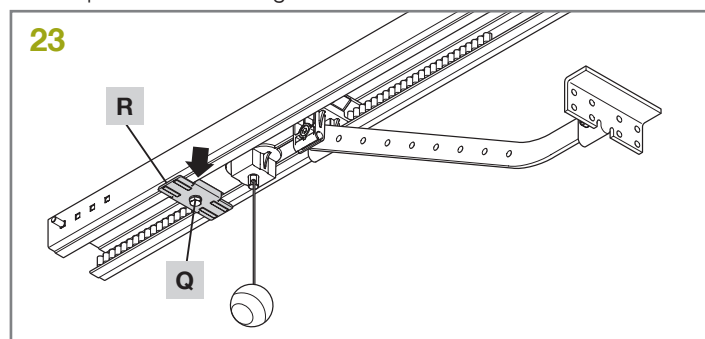

3.3 - Installation of other devices

If other devices are needed, install them following the directions provided in the corresponding instructions. Check the devices which can be connected to ELEVO in fig. 1 and in section 3.5 ("Description of electrical connections").

3.4 - Electrical connections

01. Open the cover by loosening the screw (fig. 24) and pushing the button (fig. 25).

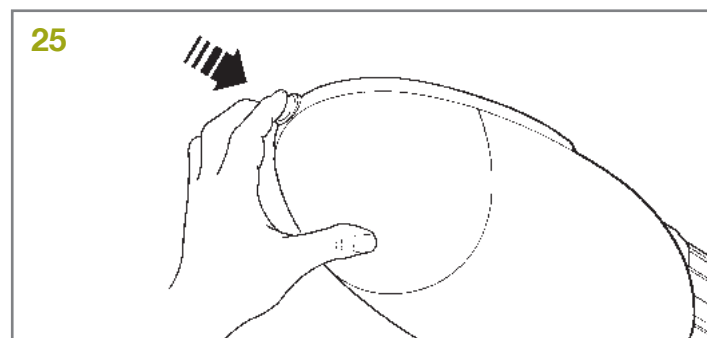
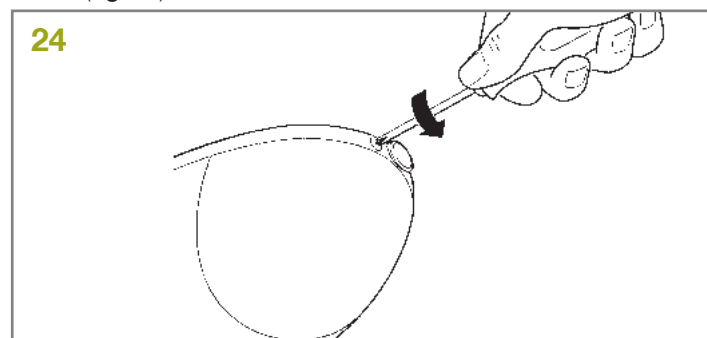

02. Remove the small disc [S] with a screwdriver (fig. 26).

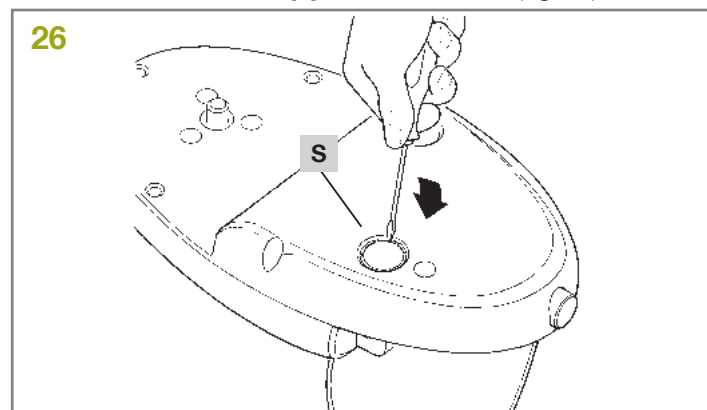

03. Feed the cables through the hole [S] (fig. 27).

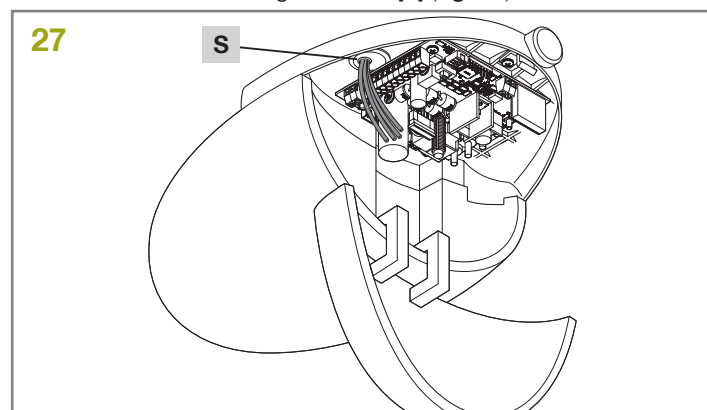

04. Refer to fig. 28 and the connection descriptions in table 5 when making the connections. If using the flashing light aerial, remove the wire clip (connected to terminal 14 as standard) and connect the RG58 shielded cable.

05. Once you have connected up all the cables, secure them using cable clips.

06. To close the cover, push it back into place, making sure you hear a "click". Reinsert and tighten the screw to finish.

4. Control unit setting

4.1 - Dip-switch adjustment

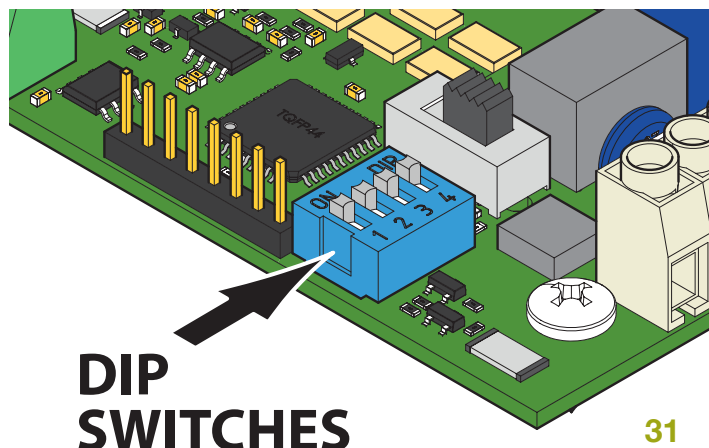

| DIP | DIP-SWITCH status | Description of operation |
|----------------|-------------------|--|
| DIP 1 STEP | 1-ON 2-OFF | Step-by-step command mode: Open / Stop / Close / Stop |
| DIP 2 AUTO | 1-ON 2-ON | Step-by-step with automatic closing (time set with the "Pause" knob) |
| | 1-OFF 2-ON | Opening only command mode with automatic closing (condominium function) |
| | 1-OFF 2-OFF | Open / Close / Open command mode (no Stop) |
| DIP 3 CHECK | ON | Test of the safety devices connected at terminal [3] "Phototest" enabled |
| | OFF | Test of the safety devices connected at terminal [3] "Phototest" disabled |
| DIP 4 FUNCTION | ON | Devices connected to "S2 Photo" terminal [4] intervene by stopping the movement both in opening and closing phases |
| | OFF | Devices connected to "S2 Photo" terminal [4] intervene just during closing phase with immediate inversion |

DIP1 "STEP":

If the dip-switch is put to **ON**, the step-by-step operating mode is activated. At every start pulse (wired or via transmitter), the control unit performs an action. Starts the motor if the automation system is stopped, and stops it if it is moving. If the **"STEP"** dip-switch is put to **OFF**, the OPEN FULLY/PAUSE/CLOSE FULLY/STOP operating mode is activated (apartment block). The control unit only accepts commands (either wired or via transmitter) for the opening phase. Starts again from zero with the set delay when the automation system is open. With the automation in the opening phase, it continues to open, and with the system in the closing phase it reopens fully. The automation can re-close with the time set through the **"PAUSE"** knob, if the **"AUTO"** dip-switch is set to **ON**. If not, it is necessary to give a START command (either wired or via transmitter) with the automation fully open.

DIP2 "AUTO":

If the dip-switch is put to **ON**, the automatic re-closing function is activated. The control unit automatically closes the leaves after the time set through the **"PAUSE"** knob (see Paragraph 4.2). If the **"AUTO"** dip-switch is put to **OFF**, the automatic re-closing function is deactivated. To close the leaves, therefore, a command must be given (either wired or via transmitter).

DIP3 "CHECK":

If the dip-switch is put to **ON**, the safety devices connected to terminal "Phototest" [3] are subject to a preventive check before starting any movement. It's necessary to connect the positive terminal of photocell's transmitter (or the normally closed contact of a safety edge) to terminal n.3 in order to use this function.

If the **"CHECK"** dip-switch is put to **OFF**, the safety devices connected to terminal "Phototest" [3] are constantly supplied.

DIP4 "FUNCTION":

If the dip-switch is put to **ON**, the safety devices connected to "S2 Photo" terminal [4] intervene by stopping the movement both in opening and closing phases. If the dip-switch is put to **OFF**, the safety devices connected to "S2 Photo" terminal [4] intervene just during closing phase with immediate inversion.

4.2 - Knob adjustment

32

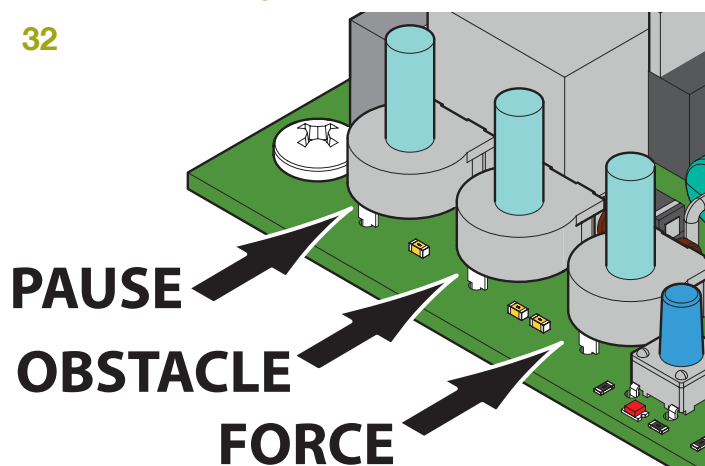

| KNOB | Description of operation |
|----------|---|
| FORCE | Power: adjustment of motor power. Turning the knob clockwise increases the motor's power and speed. To validate the modification, it is necessary to programme the gate path. |
| OBSTACLE | Obstacle, sensitivity to obstacles: adjustment of the obstacle detection function. Turning the knob clockwise increases the drive time before obstacle detection (less sensitivity). Therefore, in systems with particularly unfavorable mechanical conditions, it is advisable to keep the drive time high. OBSTACLE is set at half position (50%) as factory setup. |
| PAUSE | Pause time before automatic gate closing. Turning the knob clockwise increases the pause time from 0 to 180 seconds. Please note: this knob is functional only when AUTO dip-switch is put to ON. |

! Varying the **"POWER"** knob has no effect until the stroke is reprogrammed (par. 6).

5. Transmitter (remote control unit) programming

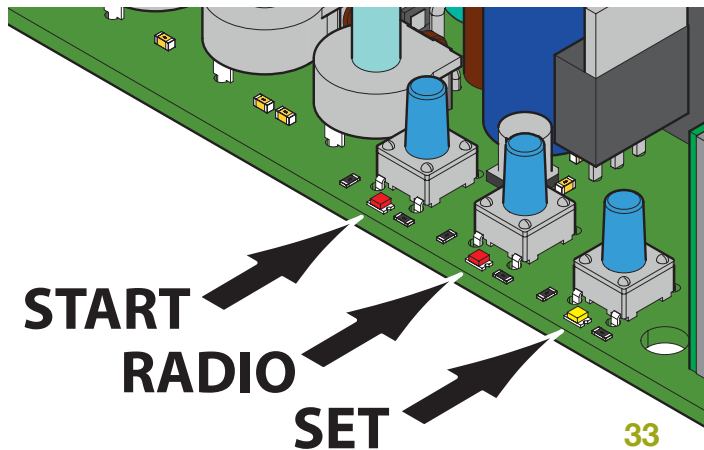

! The transmitters to be programmed must be of the “Stylo4K”, “Stylo2K”, DigiPad, Myo C4, NovoTX, NovoDigi series by King Gates. See adjacent pictures.

! If, at the start of the following procedures, the “set”, “radio” and “error” LEDs flash, it means that the programming protections have been activated – see Paragraph 14.1. Therefore, radio transmitters learning is not possible.

! To interrupt the following programming procedures at any time, press the RADIO button or wait 20 seconds.



5.1 - Start button programming

This procedure allows for programming the button of the radio control linked to the automation’s start function.

| STEP | ACTION | RESULT |
|------|--|--|
| 1 | PRESS THE RADIO BUTTON FOR 1 SECOND | The red “ radio ” LED turns on in the fixed mode (if not, consult Paragraph 14.1) |
| 2 | PRESS THE DESIRED BUTTON ON EVERY TRANSMITTER TO BE PROGRAMMED | The red “ radio ” LED flashes |
| 3 | PRESS THE RADIO BUTTON UNTIL RADIO LED TURNS OFF OR WAIT 20 SECONDS TO EXIT THE PROCEDURE | The red “ radio ” LED turns off |

5.2 - Programming of the button linked to the “Lock/AUX” output

This procedure allows for programming the button of the radio control linked to the “Lock/AUX” output (terminals 11-12).

To use this function, the Lock/AUX output must be set to courtesy light – see Paragraph 13.1.

| STEP | ACTION | RESULT |
|------|--|--|
| 1 | PRESS THE RADIO BUTTON FOR 1 SECOND | The red “ radio ” LED turns on in the fixed mode |
| 2 | PRESS THE START BUTTON FOR 1 SECOND | The red “ radio ” LED remains lit in fixed mode and the red “ error ” LED turns on in fixed mode |
| 3 | PRESS THE DESIRED BUTTON OF ALL THE TRANSMITTERS TO BE PROGRAMMED | The red “ radio ” LED flashes and the red “ error ” LED remains lit in fixed mode |
| 4 | PRESS THE RADIO BUTTON UNTIL RADIO LED TURNS OFF OR WAIT 20 SECONDS TO EXIT THE PROCEDURE | The red “ radio ” LED and the red “ error ” LED turn off |

20

5.3 - Programming of the button linked to the on-board courtesy light

This procedure allows for programming the button of the radio control linked to the on-board led courtesy light.

To use this function, the Lock/AUX output must be set to courtesy light – see Paragraph 13.1.

| STEP | ACTION | RESULT |
|------|--|---|
| 1 | PRESS THE RADIO BUTTON FOR 1 SECOND | The red “ radio ” LED turns on in the fixed mode |
| 2 | PRESS THE SET BUTTON FOR 1 SECOND | The red “ radio ” LED remains lit in fixed mode and the yellow “ set ” LED turns on in fixed mode |
| 3 | PRESS THE DESIRED BUTTON OF ALL THE TRANSMITTERS TO BE PROGRAMMED | The red “ radio ” LED flashes and the yellow “ set ” LED remains lit in fixed mode |
| 4 | PRESS THE RADIO BUTTON UNTIL RADIO LED TURNS OFF OR WAIT 20 SECONDS TO EXIT THE PROCEDURE | The red “ radio ” LED and the yellow “ set ” LED turn off |

5.4 - Deleting all memorised transmitter

This operation deletes all memorized transmitters from the memory.

| STEP | ACTION | RESULT |
|------|--|---|
| 1 | PRESS THE RADIO BUTTON FOR 4 SECONDS AND RELEASE WHEN RADIO LED FLASHES | The red “ radio ” LED flashes (if not, consult Paragraph 14.1) |
| 2 | PRESS THE RADIO BUTTON AGAIN FOR 1 SECOND | The red “ radio ” LED flashes fast |
| 3 | MEMORY DELETION COMPLETED | The red “ radio ” LED turns off |

5.5 - Deleting a single transmitter

This operation deletes a single transmitter from the memory.

| STEP | ACTION | RESULT |
|------|---|---|
| 1 | PRESS THE RADIO BUTTON FOR 4 SECONDS AND RELEASE WHEN RADIO LED FLASHES | The red “ radio ” LED flashes (if not, consult Paragraph 14.1) |
| 2 | PRESS THE SET BUTTON FOR 1 SECOND | The red “ radio ” LED flashes and the yellow “ set ” LED turns on in fixed mode |
| 3 | PRESS A BUTTON ON THE TRANSMITTER YOU WISH TO CANCEL | The red “ radio ” LED flashes and the yellow “ set ” LED flashes |
| 4 | 3. PRESS THE RADIO BUTTON UNTIL RADIO LED TURNS OFF OR WAIT 20 SECONDS TO EXIT THE PROCEDURE | The red “ radio ” LED and the yellow “ set ” LED turn off |

5.6 - Remote (tools free) transmitter programming

This procedure enables you to program a new transmitter (“Stylo2K” or “Stylo4K”) without accessing the control unit, but keeping close to it.

To run the procedure you will require a previously programmed transmitter, to inherit its functions.

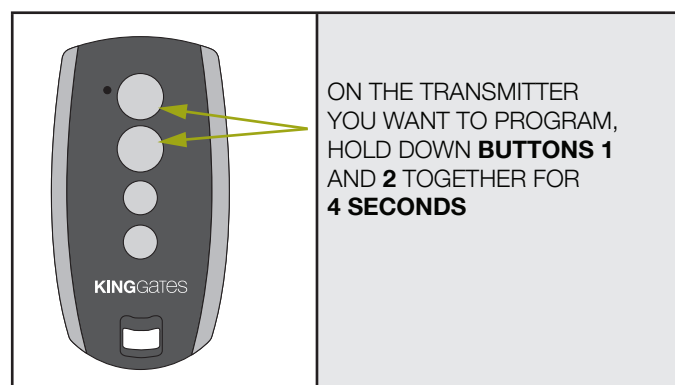
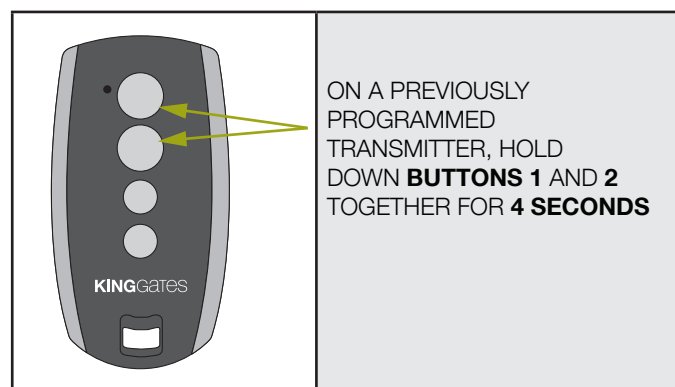

6. Programming the door path

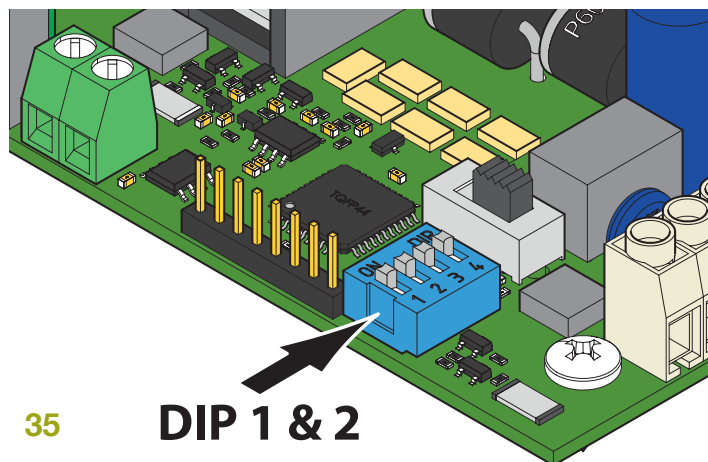
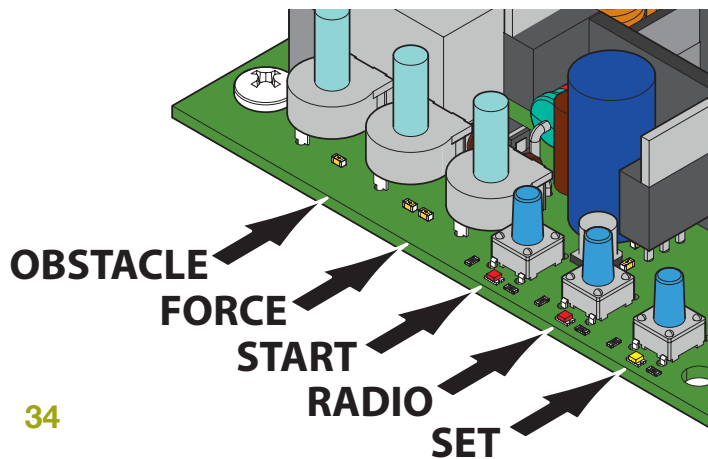

To start up the system, one of the following programming procedures must be carried out:

- basic programming of the automation's movement: self-learning of the manoeuvre times and slowdown start points.
- advanced programming of the automation's movement: self-learning of the manoeuvre times and manual setting of the slowdown start points.

! If, at the start of the following procedures, the "set", "radio" and "error" LEDs flash, it means that the programming protection has been activated – see Paragraph 14.1.

! To interrupt the following programming sequences at any time, press the SET and RADIO buttons simultaneously.

6.1 - Basic programming of the automation's movement

Through this procedure, the control unit memorizes working times and power required for opening and closing the system.

The slowdown points are automatically set to ensure a correct arrival to the end of gate path.

- For excluding slowdown, see paragraph 6.2.

| STEP | ACTION | RESULT |
|------|--|---|
| 1 | MOVE THE DOOR TO HALF WAY POSITION | |
| 2 | PRESS THE SET FOR 3 SECONDS | The yellow "set" LED flashes and then lights up permanently |
| 3 | THE DOOR PERFORMS A PARTIAL OPENING MOVEMENT | The yellow "set" LED stays on in the fixed mode |
| 4 | THE DOOR PERFORMS A FULL CLOSING MOVEMENT | The yellow "set" LED stays on in the fixed mode |
| 5 | THE DOOR PERFORMS A FULL OPENING MOVEMENT | The yellow "set" LED stays on in the fixed mode |
| 6 | THE DOOR PERFORMS A FULL CLOSING MOVEMENT | The yellow "set" LED stays on in the fixed mode |
| 7 | THE DOOR PERFORMS A FULL OPENING MOVEMENT WITH SLOWDOWNS | The yellow "set" LED turns off |
| 8 | THE DOOR PERFORMS A FULL CLOSING MOVEMENT WITH SLOWDOWNS | |
| 9 | END OF THE PROGRAMMING PROCEDURE | |

! If the "FORCE" knob is adjusted, the automation's movement must be reprogrammed.

! The red "Error" LED flashes during the automation's movement when a mechanical stress point is detected (this corresponds to increased motor effort). Adjust OBSTACLE and FORCE knobs (slightly turn them clockwise) to solve this and check gate mechanics if necessary.

6.2 - Advanced programming of the automation's movement

With this procedure, the control unit memorizes the times and power required for opening and closing the system.

Moreover, this procedure allows for setting:

- start point of slowdowns or their deletion.

| STEP | ACTION | RESULT |
|------|--|--|
| 1 | PUT THE DOOR TO HALF WAY POSITION | |
| 2 | PRESS THE SET BUTTON FOR 2 SECOND | The yellow " set " LED flashes (if not, consult Paragraph 14.1) |
| 3 | PRESS THE RADIO BUTTON FOR 1 SECOND | The yellow " set " LED turns on in the fixed mode |
| 4 | THE DOOR PARTIALLY OPENS | The yellow " set " LED stays on |
| 5 | THE DOOR MOVES TO FULL CLOSING POSITION | The yellow " set " LED flashes |
| 6 | PRESS THE SET BUTTON OR A BUTTON OF A PAIRED TRANSMITTER OR CLOSE START WIRED CONTACT | The yellow " set " LED stays on |
| 7 | THE DOOR PERFORMS THE OPENING OVEMENT | The yellow " set " LED stays on |
| 8 | PRESS THE SET BUTTON OR A BUTTON OF A PAIRED TRANSMITTER OR CLOSE START WIRED CONTACT , TO SET THE SLOWDOWN START POINT (*). FOR NOT HAVE SLOWDOWN, WAIT UNTIL THE MOVEMENT HAS BEEN COMPLETED | The yellow " set " LED stays on |
| 9 | THE DOOR COMPLETES THE OPENING PHASE | The yellow " set " LED stays on |
| 10 | PRESS THE SET BUTTON OR A BUTTON OF A PAIRED TRANSMITTER OR CLOSE START WIRED CONTACT | The yellow " set " LED stays on |
| 11 | THE DOOR PERFORMS A FULL CLOSING MOVEMENT | The yellow " set " LED stays on |
| 12 | DURING MOVEMENT: PRESS THE SET BUTTON OR A BUTTON OF A PAIRED TRANSMITTER OR CLOSE START WIRED CONTACT TO SET THE SLOWDOWN START POINT (*). FOR NOT HAVE SLOWDOWN, WAIT UNTIL THE MOVEMENT HAS BEEN COMPLETED | The yellow " set " LED stays on in the fixed mode |
| 13 | THE DOOR COMPLETES THE CLOSING PHASE | The yellow " set " LED turns off |
| 14 | END OF THE PROGRAMMING PROCEDURE | The LEDs return to the normal operation configuration |

(*) Minimum slowdown time must be 3 seconds.

⚠ If the "FORCE" knob is adjusted, the automation's movement must be reprogrammed.

⚠ The red "Error" LED flashes during the automation's movement when a mechanical stress point is detected (this corresponds to increased motor effort).

Adjust **OBSTACLE** Adjust **OBSTACLE** and **FORCE** knobs (slightly turn them clockwise) to solve this and check gate mechanics if necessary.

7. Testing and commissioning

Once the programming setup has been completed, verify that:

- the motors turn off after a few seconds once the opening or closing phases end (also "error" LED turns off);
- the control unit responds to the connected wired commands: "START" (terminal 7), and "STOP" (terminal 6);
- all programmed radio transmitters are operational;
- the safety devices connected to "S2 Photo" (terminal 4) intervene while the door closes and prevent the open door from closing;
- the safety devices connected to "S1 Edge" (terminal 9) intervene while the door opens with a stop and while it closes with a brief inversion of movement;

If the "Func" dip-switch is put to ON, check that S2 Photo safety devices intervene also when the door opens and that they prevent the closed door from opening.

8. LED indication

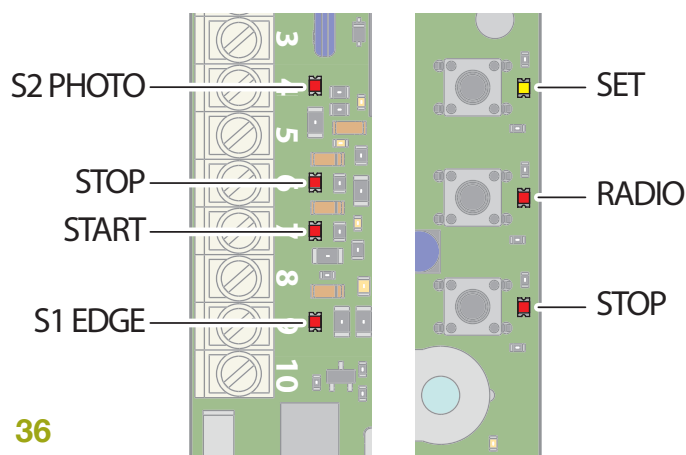

36

With the control unit powered up (if control unit protection is not activated) the yellow “Set” led flashes briefly and, if everything is correctly hooked up, the red “S1 Edge”, “Stop” and “S2 Photo” LEDs turn on to indicate that the three safety contacts are closed circuits.

The yellow “Set” LED is exclusively reserved for programming.

8.1 - Input status indication LEDs

RED S1 EDGE LED:

- on in the fixed mode if the S1 Edge contact (terminals 9-10) is closed
- off if the S1 Edge contact (terminals 9-10) is opened

RED START LED:

- on in fixed mode if the Start contact (terminals 7-8) is closed
- off if the Start contact (terminals 7-8) is opened

When START on the board is pressed or a control signal is sent by wire and the red LED flashes three times without the system executing the manoeuvre, then “wire inputs are in lock mode”: see par. 14.2 (advanced programming manual).

RED STOP LED:

- on in fixed mode if the Stop contact (terminals 6-8) is closed
- off if the Stop contact (terminals 6-8) is opened

RED S2 PHOTO LED:

- on in fixed mode if the S2 Photo contact (terminals 4-8) is closed
- off if the S2 Photo contact (terminals 4-8) is opened

YELLOW SET LED:

- is on in fixed mode or flashes when the control unit is in a programming menu
- is off when the control unit is in out of a programming menu

RED RADIO LED:

- flashes when a command is received through King Gates transmitter
- is on in fixed mode when the control unit is in a radio programming menu
- is off when the control unit is in standby mode

RED ERROR LED:

- see paragraph 8.2

RED START LED, RED RADIO LED AND YELLOW SET LED:

- If, when attempting to enter any programming scheme, the “Set”, “Radio” and “Error” LEDs flash fast three times, it means that the “control unit protection” is activated. See Paragraph 14.1 for solving the problem.

8.2 - Error status LED

RED “ERROR” LED:

The red “error” LED has two functions:

- During automation’s movement, the LED flashes when a mechanical stress point is detected (this corresponds to increased motor effort). Adjust FORCE and OBS knobs (slightly turn them clockwise) to solve this and check gate mechanics if necessary. Attention: a minimum flash of this LED during the door movement can be considered as normal.
- In standby mode, the LEDs shows the current error type with a series of regular flashes according to the following scheme:

| Number of flashes per series | Error description |
|------------------------------|---|
| 1 | On-board memory fault. |
| 2 | Photo-test of safety devices failed. See Paragraph 4.1 for solving the problem. |
| 3 | Automation’s movement programming required. See Paragraph 6. |
| 4 | Input “S1 Edge” set as a resistive edge and check failed. See Paragraph 13.4 for solving the problem. |
| 5 | Power limit threshold |
| 6 | Obstacle detection due to encoder |
| 7 | Obstacle detection due to current |

9. RESET procedure

Reset procedure deletes door travel parameters (par. 6) and all advanced functions (par. 11). It can be performed in case of programming mistakes and it brings the STAR EVO control board to factory settings.

! This reset doesn’t affect memorized radio transmitters (see par. 5 for radio transmitters management).

| STEP | ACTION | RESULT |
|------|---|---|
| 1 | PRESS THE START BUTTON FOR 8 SECOND | All LED flash |
| 2 | RELEASE START BUTTON | All LED continue to flash |
| 3 | PRESS THE START BUTTON FOR 3 SECOND | All LED light up in series |
| 4 | RESET IS NOW COMPLETED | The red “ERROR” LED lights flashes 3 times continuously |
| 5 | A NEW PROGRAMMING OF THE AUTOMATION’S MOVEMENTS IS REQUIRED | |

10. Devices connectable to the control unit

EN

37

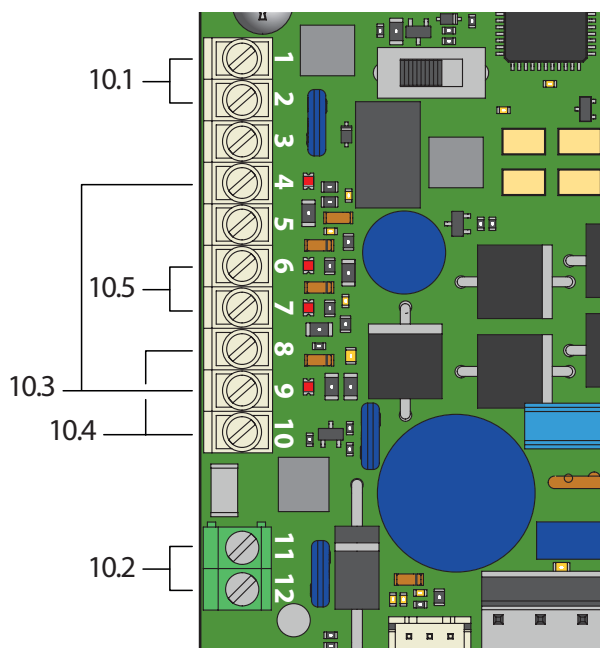
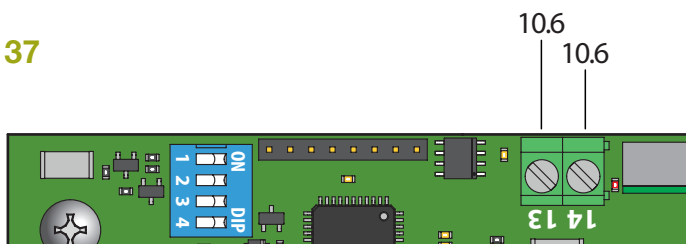

The control unit is prearranged for interfacing with different devices dedicated to system control, system safety and other additional functions. Below is a list of their connections and corresponding functions.

10.1 - Warning light

TERMINALS: 1-2.

The warning light is an accessory used for signaling any movement of the gate leaf.

Connected lamps: 24V 15W maximum power.

10.2 - AUX contact

TERMINALS: 11-12.

Default setting: 12V electric lock operation.

The AUX can be set to electric lock, magnetic lock, courtesy light (monostable or bistable). Also, voltage output is customizable to 24V. To change the AUX setup, refer to the advanced programming functions of Paragraph 13:

- Selection of AUX output type (Paragraph 13.1) = set as lock or courtesy light;
- Selection of AUX operating mode (Paragraph 13.2) = allows for customizing the contact's operation;
- Selection of AUX contact voltage (Paragraph 13.3) = allows for selecting the AUX contact voltage (12V or 24V).

10.3 - Safety devices

TERMINALS: 4-9-10.

Control unit has two safety inputs available for voltage free (dry contact) connection(s).

“S2 Photo” CLOSING or OPENING/CLOSING PHASE SAFETY DEVICES
Terminals 4,8 allow connection of safety devices active during closing and opening phase. This input is normally closed (NC). For infra-red photocells and safety edges with micro-switch contact.

The factory wire bridge connected to S2 Photo must be removed when using this input.

These devices intervene during the gate's closing and opening phase according to DIP switch 4 (see par. 4.1).

In particular:

DIP4 set to ON:

- during the closing phase they block the movement and open the door for disengagement
- during the opening phase they block the movement and open the door to the disengagement
- with the opened door they lock closing commands
- with the closed door they lock opening commands

DIP4 set to OFF:

- during the closing phase they immediately reverse the movement and reopen the door fully
- during the opening phase they have no effect
- with the opened door they lock closing commands
- with the closed door they have no effect

Figures 38a, 38b and 38c show examples of King Gates “Viky30” photocell connections.

⚠ When multiple devices are connected on this contact, they must be series connected (see Fig. 38c).

⚠ If more photocell pairs are connected, RX and TX units of the safety set should be cross installed (see Fig. 38c).

“S1 Edge” OPENING/CLOSING PHASE SAFETY DEVICES

It is possible to connect devices (e.g. photocells or edges) with normally closed (NC) contact or 8K2 resistive edges to the “S1 Edge” input (terminal 9-10).

The factory wire bridge connected to PHO2 must be removed when using this input.

These devices intervene while the door is moving, in particular:

- with the closed door they lock opening commands.
- with the opened door they lock closing commands.
- during the closing phase they command a brief inversion
- during the opening phase they block the movement

Figures 38a, 38b and 38c show examples of King Gates “Viky30” photocell connections.

⚠ When multiple devices are connected on this contact, they must be series connected (see Fig. 38c).

⚠ If more photocell pairs are connected, RX and TX units of the safety set should be cross installed (see Fig. 38c).

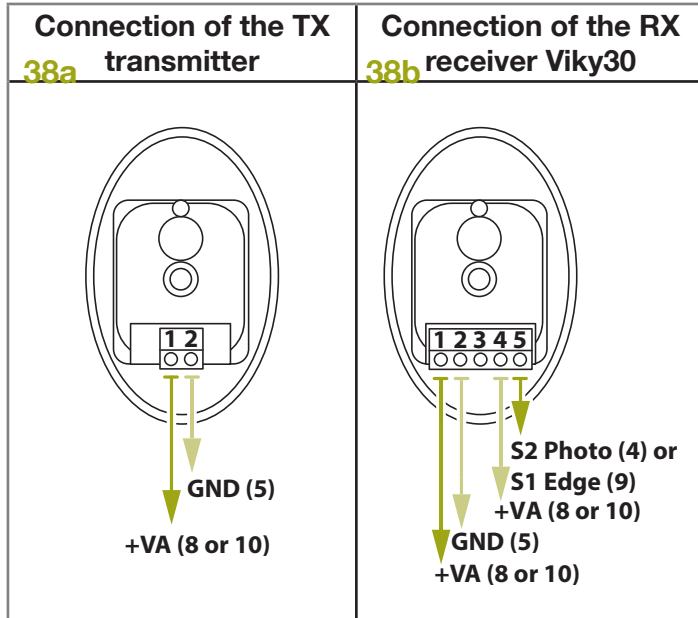

Connection of multiple receiver pairs Viky30

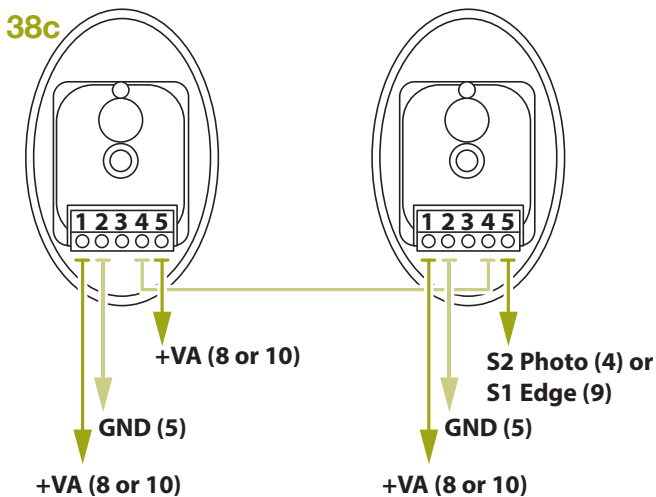

Receiver pair 1

RX1

Transmitter pair 1

TX1

Transmitter pair 2

TX2

Receiver pair 2

RX2

10.4 - 24V \equiv accessories' power supply

TERMINALS: 8-5, 10-5.

Nominal voltage 24V \equiv , max. 250mA, output for powering external accessories as photocells, radio receivers, etc. Real voltage output can be greater than nominal value, check the compatibility of external accessories.

10.5 - Wired commands

TERMINALS: 6-7-8-10.

Inputs for the start, stop wired commands can be customized to open, stop (Paragraph 15.1).

They can be locked to prevent tampering with the system (Paragraph 15.2).

START CONTACT

The "START" input (terminals 7-8) is a normally open gate activation command by wire.

The activation method is set up by dip switches 1 and 2 - see Paragraph 4.1.

This input is a voltage free (dry contact) only. Connecting power to this input will void warranty.

⚠ TIMER FUNCTION: if START contact is kept closed (for instance through a timer-controlled or bistable relay), control unit opens the gate and leaves the gate opened. The automation does not accept closing commands (neither automatic nor wired) until START contact is reopened.

In this mode, dip switch 1 STEP is set to OFF and dip 2 AUTO to ON to ensure that the gate never remains locked open.

⚠ If multiple START contacts are connected, connect the contacts in parallel.

⚠ If START contact is kept closed during the control unit starting after a blackout, the gate will immediately execute the start command.

STOP CONTACT

The "STOP" input (terminals 6-8) is for immediately stopping and locking any movement of the gate.

This input is a normally closed and voltage free (dry contact) only. Connecting power to this input will void warranty.

To restore operation this contact must be closed.

10.6 - Antenna

TERMINALS: 13-14.

Antenna terminal for transmitter signal reception. A wire is factory connected to this terminal.

For extending the reception range, an external antenna can be connected (present in the King Gates flashing lights range).

If an external antenna is connected, the series connected wire must be disconnected.

11. Advanced programming

The control unit has additional special features not required for most of standard installations. All descriptions are reported here below.

12. Backjump adjustment

This procedure allows for adjusting or eliminating the backjump. It consists in inverting the door movement at the end of the path to perform belt recovery, facilitate unlocking and safeguard the mechanical system. On certain installations this is unnecessary, therefore this value can be adjusted.

DEFAULT: STAR EVO backjump = value 2, equal to 500ms

⚠️ Prior to proceeding with this programming procedure, first verify whether either the “basic path programming” or the “advanced path programming” have been completed.

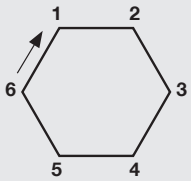
| STEP | ACTION | RESULT |
|-------------------------------|--|--|
| 1 | PUT THE DOOR IN THE CLOSED POSITION | |
| 2 | PRESS THE START BUTTON FOR 3 SECOND | All the LEDs turn off (if not, consult Paragraph 14.1) |
| 3 | PRESS THE SET BUTTON FOR 1 SECOND | The yellow “ set ” LED turns on in the fixed mode and the red “ error ” LED indicates the backjump* level |
| 4 | PRESS THE SET BUTTON FOR 1 SECOND | The yellow “ set ” LED flashes then turns on in the fixed mode and the “ error ” LED indicates the backjump* level |
| backjump value setting | | |
| 5 | <p>EVERY TIME THE SET BUTTON IS PRESSED, THE VALUE CHANGES FROM 1 TO 6 STARTING FROM THE CURRENTLY SET VALUE</p>  <p>example 1: current backjump = 3 after SET is pressed, backjump = 4 example 2: current backjump = 5 after SET is pressed 2 times, backjump = 1</p> | <p>The yellow “set” LED remains lit in the fixed mode and the red “error” LED indicates the backjump* level</p> |

| saving of the set backjump | | |
|-----------------------------------|---|---|
| 6 | PRESS THE RADIO BUTTON FOR 2 ECOND | The yellow “ set ” LED remains lit in the fixed mode and the red “ error ” LED flashes fast |
| 7 | PRESS THE SET AND RADIO BUTTONS SIMULTANEOUSLY OR WAIT 10 SECONDS TO EXIT THE PROCEDURE | The LEDs return to the normal operation configuration |

* The backjump value is indicated by the number of flashes of the series based on the set value.

Backjump levels: 0 / 500mS / 700mS / 1Sec / 1,5 Sec / 2Sec.

When the series consists of one flash, the backjump value is zero (no inversion of movement at end-of-path), when there are 6 flashes, the backjump is set to the maximum value.

Clearly, the other series indicate growing intermediate values from 1 to 6.

The backjump value can be known at any time after the SET button is pressed the first time, by counting the number of flashes of the green “photo” LED.

⚠️ If the backjump value is set too high, some undesired clearance may remain between the door and the mechanical stop.

13. AUX output programming

These programming sequences are not essential to the system's operation, though they allow for setting the type (lock or courtesy light), of the devices connected to the AUX output.

To interrupt the following programming sequences at any time, press the **SET** and **RADIO** buttons simultaneously or wait 10 seconds.

AUX USED AS COURTESY LIGHT

If the AUX output is used as courtesy light for controlling the lamps, a relay **must be connected**.

The light can be activated through a dedicated transmitter button (to be programmed as indicated in Paragraph 5.2).

ACTIVATION OF THE LIGHT THROUGH A DEDICATED TRANSMITTER BUTTON AND TIMER-BASED SWITCHING OFF:

- connect a **timer relay** and set the desired switch-on time for the light;
- set the AUX output on courtesy light (see Paragraph 13.1);
- program the desired transmitter button for the light command (see Paragraph 5.2).

The light will switch on with the programmed transmitter and switch off after the time set on the relay elapses.

SWITCHING ON/OFF OF THE LIGHT THROUGH A DEDICATED TRANSMITTER BUTTON:

- connect a **monostable relay**;
- set the AUX output on courtesy light (see Paragraph 13.1);
- program the desired transmitter button for the light command (see Paragraph 5.2).

The light switches on/off whenever the programmed transmitter is pressed.

ACTIVATION OF THE COURTESY LIGHT LINKED TO THE WIRED OR TRANSMITTER START BUTTON:

- connect a **timer relay** and set the desired switch-on time for the light;
- set the AUX output as electric lock (see Paragraph 13.1);
- if desired, program the transmitter button for the START command (see Paragraph 5.2).

At every wired or transmitter start command, the light will switch on for the set time.

13.1 - Selection of device connected to "Lock/AUX" output

Default = electric lock

This procedure allows for setting the "AUX" output for the operation as:

ELECTRIC LOCK: the control unit closes the AUX contact (terminals 11-12) whenever a command is received.

By default, the contact is closed for 3 seconds (electric lock mode). **COURTESY LIGHT:** the control unit closes the AUX contact (terminal 11-12) whenever a radio command is received (the AUX button must be programmed – see Paragraph 5.2). By default, the command is monostable.

⚠ To control the AUX output when it has been set as a courtesy light output, you need to register a transmitter by following the procedure in paragraph 5.2 and connect a suitable relay.

| STEP | ACTION | RESULT |
|-----------|--|--|
| 1 | PRESS START BUTTON FOR 3 SECONDS | All the LEDs turn off (if not, consult Paragraph 14.1) |
| 2 | PRESS THE RADIO BUTTON FOR 1 SECOND: | |
| 2.1a | If the yellow "Set" LED is on AUX = Electric lock (if the setting is correct, go to Point 4; if not, proceed to Point 3a) | The red " radio " LED turns on in the fixed mode |
| 3a | Courtesy light setting PRESS THE RADIO BUTTON FOR 1 SECOND | The red " radio " LED remains lit in the fixed mode and the red " Error " LED lights up. The yellow " Set " LED goes off. |
| <i>or</i> | | |
| 2.1b | If the red "Error" LED is on in fixed mode AUX = Courtesy light (if the setting is correct, go to Point 4; if not, proceed to Point 3b) | The red " radio " LED turns on in the fixed mode |
| 3b | Electric lock setting PRESS THE RADIO BUTTON FOR 1 SECOND | The red " radio " LED remains lit in the fixed mode and the yellow " Set " LED lights up. The red " Error " LED goes off |
| 4 | PRESS THE SET AND RADIO BUTTONS SIMULTANEOUSLY OR WAIT 10 SECONDS TO EXIT THE PROCEDURE | The LEDs return to the normal operation configuration |

13.2 - Selection of the type of devices connected to “S1 Edge”

Default = “S1 Edge” set for devices with normally closed contact (terminal 9)

This procedure allows for setting the “S1 Edge” output for managing 8.2kOhm resistive edges.

The control unit constantly verifies the integrity of the edge by measuring the resistance between the two dedicated terminals.

| STEP | ACTION | RESULT |
|-----------|--|--|
| 1 | PRESS START BUTTON FOR 3 SECONDS | All the LEDs turn off (if not, consult Paragraph 14.1) |
| 2 | PRESS THE START BUTTON FOR 1 SECOND | |
| 2.1a | If the yellow “Set” LED is on “S1 Edge” = resistive edge (if the setting is correct, go to Point 4; if not, proceed to Point 3a) | The red “ error ” LED turns on in the fixed mode |
| 3a | device with normally closed (NC) contact PRESS THE START BUTTON FOR 1 SECOND | The red “ error ” LED remains lit in the fixed mode and the yellow “ Set ” LED turns off |
| or | | |
| 2.1b | If the yellow “Set” LED is off “S1 Edge” = device with normally closed (NC) contact (if the setting is correct, go to Point 4; if not, proceed to Point 3b) | The red “ error ” LED turns on in the fixed mode |
| 3b | 8.2 kOhm resistive edge PRESS THE START BUTTON FOR 1 SECOND | The red “ error ” LED remains lit in the fixed mode and the yellow “ Set ” LED turns on |
| 4 | PRESS THE SET AND RADIO BUTTONS SIMULTANEOUSLY OR WAIT 10 SECONDS TO EXIT THE PROCEDURE | The LEDs return to the normal operation configuration |

⚠ In order to carry out the check on the safety devices, the connected edges must be of the resistive type with 8.2 kOhm.

14. Other functions

⚠ To interrupt the following programming sequences at any time, press the SET and RADIO buttons simultaneously or wait 10 seconds.



14.1 - Activating/deactivating the control unit protection device

Default = control unit protection device not active.

This programming sequence allows for locking all control unit programming sequences and the settings adjustable through the dip-switches. To perform a new programming sequence or make a dip-switch/trimmer modification effective, the protection must be deactivated.

| STEP | ACTION | RESULT |
|-----------|---|---|
| 1 | PRESS START BUTTON FOR 3 SECONDS | All the LEDs turn off |
| 2.1a | If the yellow led "Set" and the red led "Radio" are ON: central unit lock = enabled (if it is the correct setting, go to step 4, otherwise proceed to step 3a) | |
| 3a | Disabling control unit setup PRESS BOTH BUTTONS START AND RADIO , FOR 2 SECONDS | The yellow led " set ", the red led " radio " and red led " start " go OFF |
| or | | |
| 2.1b | If the yellow led "Set" and the red led "Radio" are OFF: central unit lock = disabled (if it is the correct setting, go to step 4, otherwise proceed to step 3b) | |
| 3b | Enabling control unit setup PRESS BOTH BUTTONS START AND RADIO , FOR 2 SECONDS | The yellow led " set ", the red led " radio " and red led " start " go ON |
| 4 | PRESS BOTH BUTTONS SET AND RADIO SIMULTANEOUSLY OR WAIT 10 SECONDS TO EXIT THE PROCEDURE | All the LEDs go back to standard behavior |

15. F.A.Q

EN

| | Problem | Symptoms / Causes | Solution |
|-----------|---|---|--|
| 9a | The control unit LEDs are turned off | No power to the control unit. | Check for mains power – see Paragraph 3.4 / 3.5. For solar/ battery power check 24V  power to the board. |
| | | The fuses blown. You must disconnect power before touching fuses. Check for no short-circuits or problems before replacing fuse with same value ones. | Replace the fuses. If the fuses blow up again, check for short circuits or damages of power circuits, cables, wires, accessories, transformer and control unit. |
| 9b | The control unit cannot enter to programming mode | When the SET button is pressed and all the indication LEDs flash the control unit is in protection mode. | Deactivate the protection – see Paragraph 14.1 |
| 9c | The control unit completes the programming setup, but does not respond to commands in the standard operating mode | Problem with safety and/or stop circuits if Photo and/or Stop red LEDs are off. Those LEDs must be lit red unless the door will not work. | Check that the “S2 Photo”, “S1 Edge” and “Stop” circuits are closed. |
| | | Photo-test of safety devices failed. After a command is pressed for a few seconds, the red “Error” LED turns on. | Deactivate the photo-test – see Paragraph 4.1. |
| 9d | Door is moving but not all the way to fully close and/or open. | Obstacle detection problems. The control unit detects power draw peaks during the manoeuvre and goes into obstacle mode. | 1. Disengage the door from the motor(s) with manual release; check door to move free all the way. If not, please fix. 2. Turn the “OBS” knob slightly clockwise (see Paragraph 4.2) A) make sure that control unit stops powering the motor(s) at the end of the travel. 3. If not sufficient, turn the “POWER” knob slightly clockwise and reprogram automation’s movement. 4. Avoid/reduce slowdown travel phase (see Paragraph 6.2) |
| | | Intervention of the safety devices. Check that the red “S2 Photo”, red “S1 Edge” and “Stop” LEDs remain lit throughout the entire manoeuvre. If there are multiple photocell pairs, these may signal false obstacles. | Apply the bridges to “S2 Photo”, “S1 Edge” and “Stop” to check if the problem is from the control unit or other circuits connected to these terminals (see paragraph 10 and image 38C). |
| 9e | The radio transmitter does not functioning | Check that LED on the transmitter is flashing, if not replace the transmitter’s battery | Check that radio LED of the control unit flashes while pressing a button on the transmitter. If yes, try to reprogram the radio transmitter. |
| 9f | The transmitter has little range | Note: transmitter’s range varies in relation to the environmental conditions | Replace the transmitter’s battery. Connect an external antenna (see Paragraph 10.8) if not sufficient. |
| 9g | The door does not slowing down | Repeating the automation’s movement programming is required | 1. Repeat the automation’s movement programming (see Paragraph 6.1) 2. If not sufficient, do the advanced programming of the automation’s movement (Paragraph 6.2) and set a longer slowdown area. |
| 9h | The control unit does not make the dip-switch or knobs adjustments | The control unit protection (lock mode) is active. | Deactivate the control unit lock. See Paragraph 14.1 |
| | | No effect with “POWER” knob or dip-switches adjustment | To make “POWER” knob and dip-switches changes effective, it is necessary to repeat the automation’s movement programming. If not possible, deactivate the control unit lock. See Paragraph 14.1. |

16. Technical specifications

King Gates srl, in order to improve its products, reserves the right to modify their technical specifications at any time without prior notice. In any case, the manufacturer guarantees their functionality and suitability for the intended purposes.

All the technical characteristics refer to a room temperature of 20°C (±5°C).

| OVO technical specifications | |
|---|--|
| Type | Electromechanical gearmotor for the automatic movement of garage doors for residential use, complete with electronic control unit |
| Pinion | 9.5 mm diameter, 28 teeth |
| Peak starting torque [corresponds to the force necessary to keep set the leaf in motion] | 620N (ELEVO 620) 1000N (ELEVO 1000) |
| Speed under no load [corresponds if "Fast" speed is programmed] | 0.17m/s |
| Operating limits | In general, ELEVO is suitable for the automation of sectional or overhead doors which remain within the dimensions stated in table 1 |
| ELEVO power supply | 230Vac (±10%) 50/60Hz. |
| Max. absorbed power | 200 W (ELEVO 620) 300 W (ELEVO 1000) |
| Insulation class | 1 (a safety grounding system is required) |
| Emergency power supply | No |
| ELEVO courtesy light | LED |
| Flashing Light Output | for 1 flashing light (24V, 15W) |
| Working temp. | -20°C ÷ +55°C |
| Use in acid, saline or potentially explosive atmosphere | No |
| Protection class | IP 40 use only in indoor or protected environments |
| Dimensions and weight | 225 x 330 h 100 / 3.3 kg |

| Guide technical characteristics | | |
|---------------------------------|-------------------------------------|------------------------------------|
| | GRO33 | GRO13 |
| Type | 3-piece profile in galvanised steel | single profile in galvanised steel |
| Guide length | 3.15 m | 3.15 m |
| Guide height | 35 mm | 35 mm |
| Useful stroke | 2.6 m | 2.6 m |
| Belt length | 6 m | 6 m |
| Belt height | 6 mm | 6 mm |

| Incorporated radio receiver technical specifications | |
|--|---|
| Type | 4 channel receiver for incorporated radio command |
| Frequency | 433.92 MHz |
| Coding | King |
| Transmitter compatibility (*) | DigyPad, Stilo 4K, Myo C4, Novo TX and Novo Digy |
| No. of transmitters that can be memorised | 170 remotes |
| Input impedance | 50 Ω |
| Sensitivity | better than 0.5µV |
| Range of the transmitters | From 100 to 150m. The range can vary if there are obstacles or electromagnetic disturbances, and is also affected by the position of the receiving aerial |
| Outputs | / |
| Working temp. | -20°C ÷ 55°C |

17 - EU Declaration of Conformity and declaration of incorporation of “partly completed machinery”

EN

| | |
|--|--|
| Document | N. 1001 |
| Language | English (translated from Italian) |
| Revision | 2 |
| Manufacturer's Name: | KING GATES S.r.l. |
| Address: | Via Malignani, 42 - 33077 - Sacile (PN) Italy |
| Authorized Person to constitute the technical documentation: | KING GATES S.r.l. |
| Address: | Via Malignani, 42 - 33077 - Sacile (PN) Italy |
| Type of product: | Electromechanical gearmotor for sectional doors with control unit and receiver |
| Model/Type: | ELEVO 620 ELEVO 1000 |
| Accessories: | refer to the catalog |

The undersigned, Giorgio Zanutto, in the role of Chief Executive Officer, declares under his sole responsibility, that the product specified above conforms to the provisions of the following directives:

- Directive 2014/53/UE (RED)
 - Health protection standards (art. 3(1)(a)): EN 62479:2010
 - Electrical safety (art. 3(1)(a)): EN 60950-1:2006 + A11:2009 + A12:2011 + A1:2010 + A2:2013
 - Electromagnetic compatibility (art. 3(1)(b)): EN 301 489-1 V2.2.0:2017, EN 301 489-3 V2.1.1:2017
 - Radio spectrum (art. 3(2)): EN 300 220-2 V3.1.1:2017

The product also complies with the following directives according to the requirements envisaged for “partly completed machinery” (Annex II, part 1, section B):

Directive 2006/42/EC OF THE EUROPEAN PARLIAMENT AND COUNCIL of 17 May 2006 related to machinery, and which amends the directive 95/16/EC (recast).

- It is hereby declared that the pertinent technical documentation has been compiled in compliance with appendix VII B of directive 2006/42/EC and that the following essential requirements have been observed:
1.1.1- 1.1.2- 1.1.3- 1.2.1-1.2.6- 1.5.1-1.5.2- 1.5.5- 1.5.6- 1.5.7- 1.5.8- 1.5.10- 1.5.11
- The manufacturer undertakes to transmit to the national authorities, in response to a motivated request, all information regarding the “partly completed machinery”, while maintaining full rights to the related intellectual property.
- Should the “partly completed machinery” be put into service in a European country with an official language other than that used in this declaration, the importer is obliged to arrange for the relative translation to accompany this declaration.
- The “partly completed machinery” must not be used until the final machine in which it is incorporated is in turn declared as compliant, if applicable, with the provisions of directive 2006/42/EC.

The product also complies with the following standards:

EN 60335-1:2012+A11:2014, EN 62233:2008
 EN 60335-2-95:2015+A1:2015
 EN 61000-6-2:2005, EN 61000-6-3:2007+A1:2011

Place and Date: Sacile 16/11/2018

Giorgio Zanutto
 (Chief Executive Officer)





+39 0434 1859988

Technical support

Monday/Friday 8.30-12.30 ; 14-18
(UTC+01:00 time)



More



IST. STAREVO cod.IS0650B01MM - 05/2019

Dati dell'installatore / Installer details

Azienda / Company _____

Timbro / Stamp _____

Località / Address _____

Provincia / Province _____

Recapito telefonico / Tel. _____

Referente / Contact person _____

Dati del costruttore / Manufacturer's details

KINGGates

King Gates S.r.l.

Phone +39.0434.737082
info@king-gates.com

Fax +39.0434.786031
www.king-gates.com

