

Book

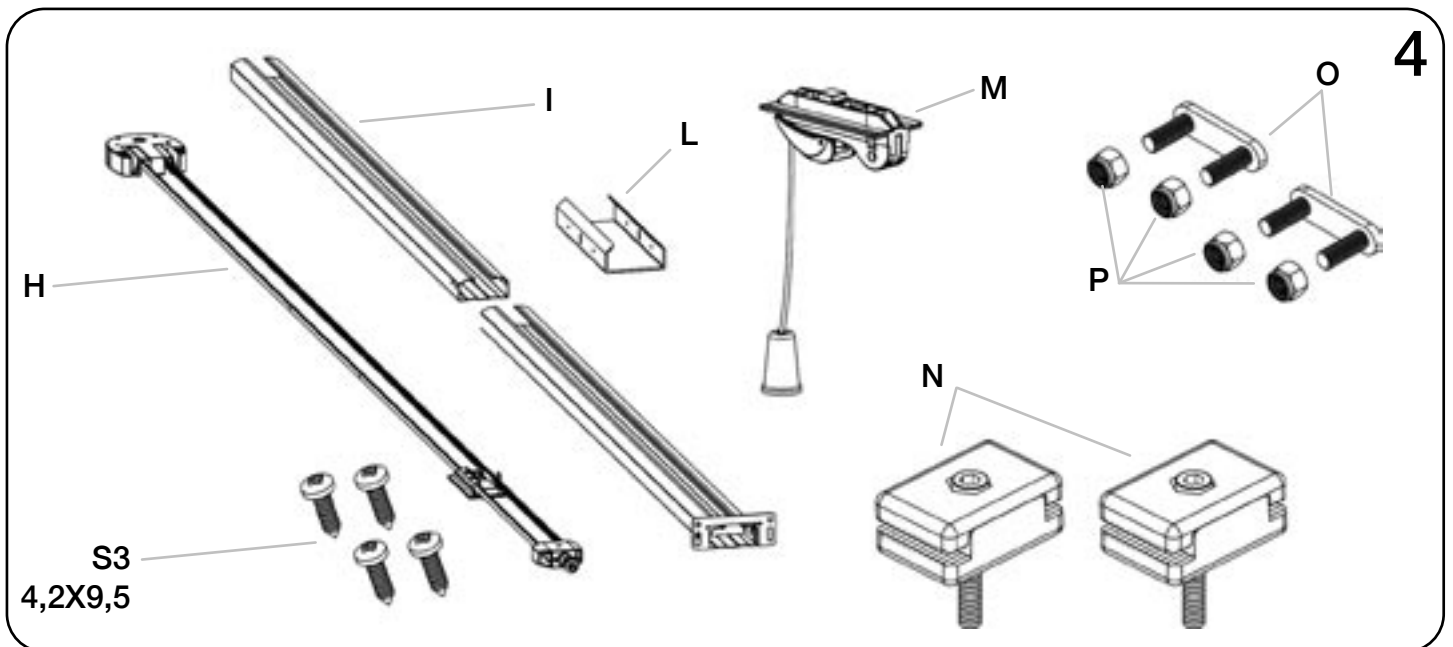

EN INSTRUCTION MANUAL

MADE IN ITALY

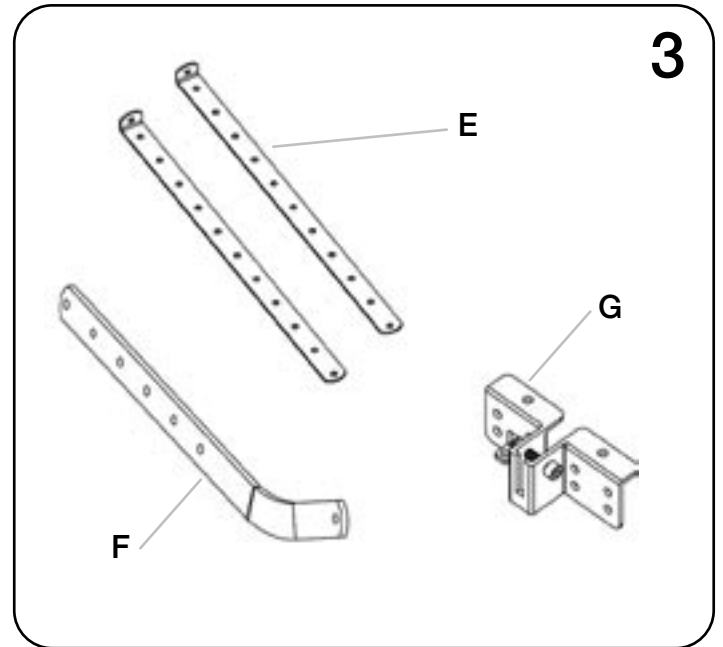
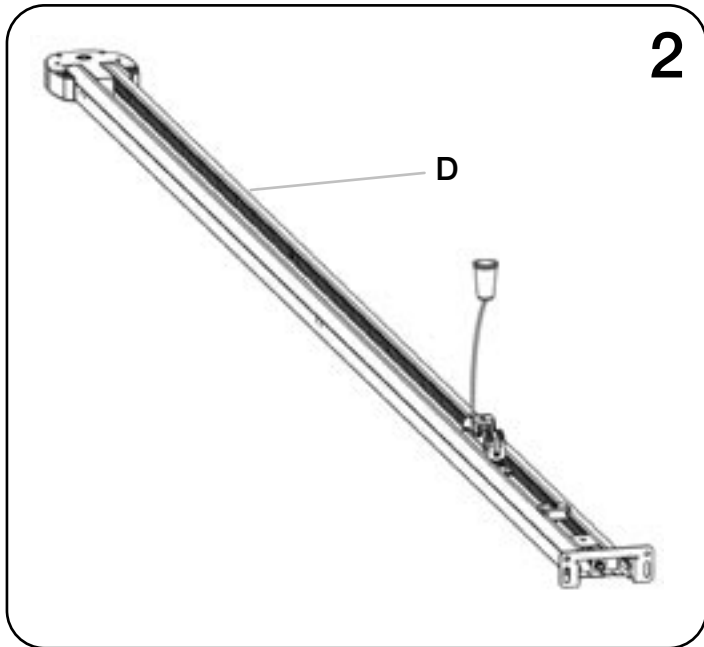
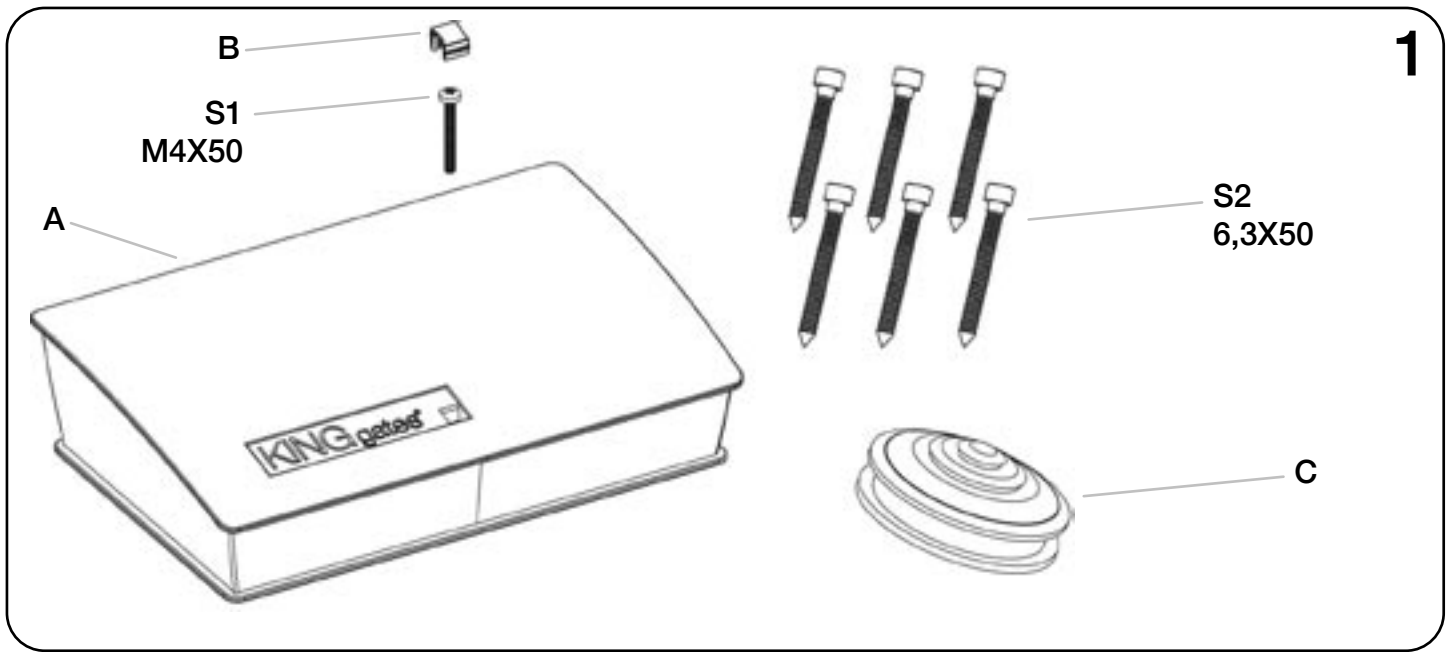

1 - PRODUCT DESCRIPTION

1A - WARNINGS

- Before installing the product ascertain that safety conditions are observed according to the law, rules and regulation. Use personal safety devices and locate warning signs on the motorized gate. Unfulfilment of the below listed direction will release the Antonioli Mario & C. sas, holder of the KING gates mark, from any responsibility for damage caused to people or things.
- Ascertain the integrity of the packing when opening it.
 - In case of anomalies in the functioning, turn immediatly off the gear motor, disconnect electrical power and operate the gate manually the problem has been found and salved.
 - Do not modify the product in any part.
 - Only authorized and qualified staff is alloned to disassemble the product.
 - Prevent any part of the automation from being next to any source of heat or in contact with liquid substances.
 - Use only adeguate power supply cables.
 - To optimize the functioning of the automation, King gates accessories only.
 - Disposal of waste material has to observe local regulations.
 - Installing, testing and first functioning have to observe the laws in force.

1B - AVAILABLE VERSION

AVAILABLE VERSION - MOTOREDUCTOR

Code	Motor	Control unit	Radio Receiver	Led	Encoder	Newton max	Content of the package
Book 550	24 Vdc	Star GD 20	●		●	550	See picture 1
Book 550 Led	24 Vdc	Star GD 20 Led	●	●	●	550	See picture 1
Book 1000 Led	24 Vdc	Star GD 40 Led	●	●	●	1000	See picture 1

AVAILABLE VERSION - RAILS

Code	Kind of transmission	Slide lenght	Door max height	Kind of slide	Content of the package
Grb 3 - Glb 3	Belt	3 m	2,45 m	1 x 3 m	See pictures 2 and 3
Grb 23		3 m	2,45 m	2 x 1,5 m	See pictures 2 and 3
Grb 4		4 m	3,45 m	3 m + 1 m	See pictures 2 and 3

CONTROL UNIT TECHNICAL DATA

Book 550

Book 1000 Led

Maximum torque	9 Nm	19 Nm
No load speed of the shaft	50 Rpm	54 Rpm
Nominal speed of the shaft	55 Rpm	42 Rpm
No load speed of the carriage	13 cm/s	11 cm/s
Nominal speed of the carriage	12 cm/s	9 cm/s
Maximum frequency working cycles	70 cycles/day	80 cycles/day
Control unit supply	230 ± 10% (50-60 Hz)	230 ± 10% (50-60 Hz)
Motor output	24 V	24 V
Motor power	40 W	80 W
Courtesy light	Light on board (24V,10W)	A LED (24V)
Flashing lamp output	24V (max 15W)	24V (max 15W)
Accessories output	24V (400 mA)	24V (400 mA)
Stop input	NC	NC
Antenna input	52 ohm (RG58)	52 ohm (RG58)
Radio receiver on board	433.92 MHz (max 50 radiotransmitters)	433.92 MHz (max 50 radiotransmitters)
Working temperature	da -20 a +55 °C	da -20 a +55 °C
Level of protection	IP40	IP40
Dimensions and weight	380x246x96 mm / 5 kg	380x246x96 mm / 5 kg
Max dimensions overhead door	8 mq	12 mq

2 - OPERATING LIMITS

2A - TYPICAL SYSTEM

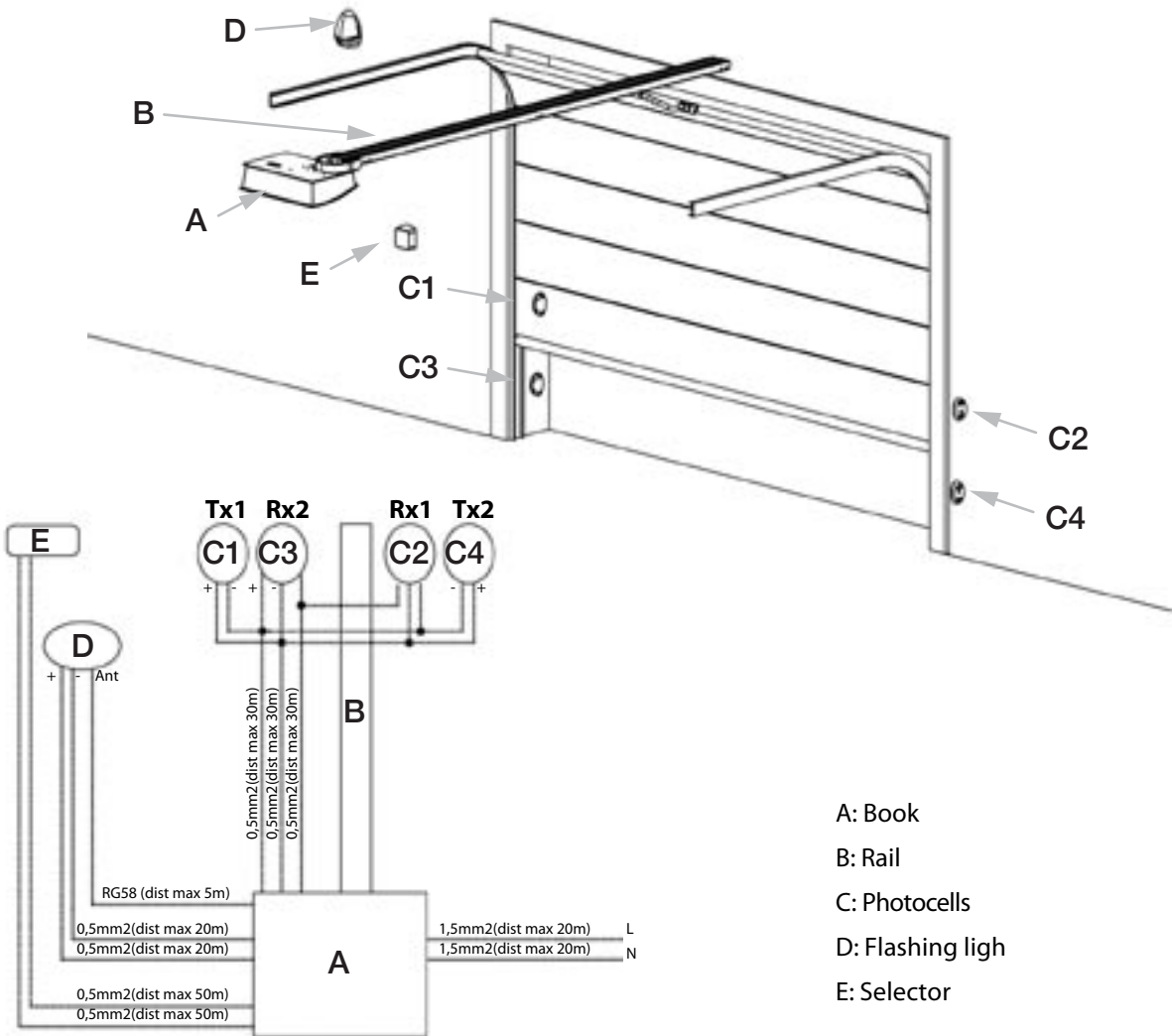

2B - DIMENSIONS

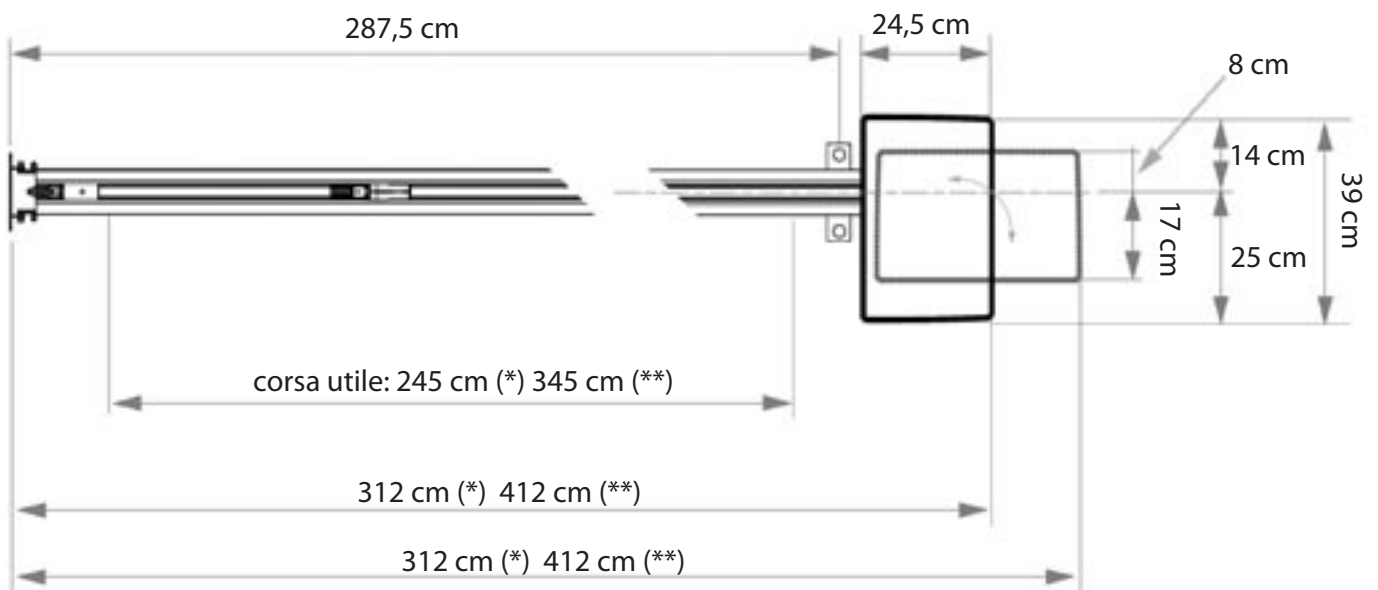

(*) Grb 3, Grb 23, Glb 3

(**) Grb4

2C - APPLICATION SET

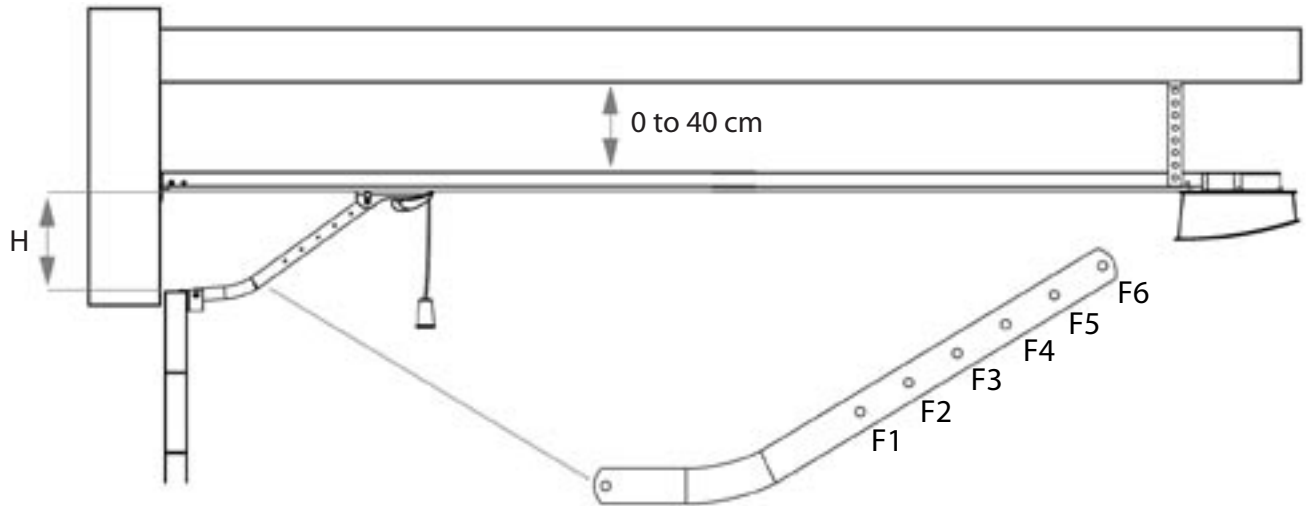

The values on the table refer to the effective run depending both on distance “H” and the used hole “F”

H (cm)	F1	F2	F3	F4	F5	F6
0	244	240	236	232	228	224
2	244	240	236	232	228	224
4	244	240	236	232	228	224
6	245	241	237	233	229	225
8	245	241	237	233	229	225
10		242	238	234	230	225
12		243	239	234	230	226
14		245	240	235	231	227
16			241	237	232	228
18			243	238	233	229
20			245	239	235	230
22				241	236	231
24				244	238	233
26					240	234
28					243	236
30						239
32						241
34						245

3 - INSTALLATION

3A - INTRODUCTION

In order to assemble the rails, proceed as shown in the following paragraphs.
If the rail is "GRB3" (3X1m) skip the paragraph 3A because the rail is preassembled.

3B - ASSEMBLING THE GUIDE "GRB23" (1.5m X 2) OR "GRB4" (3m+1m)

- 1 - Prepare the two profiles and the joint and fasten them by the four screws (detail 2)
- 2 - Insert the fastenings for the brakets (details 3 and 4)

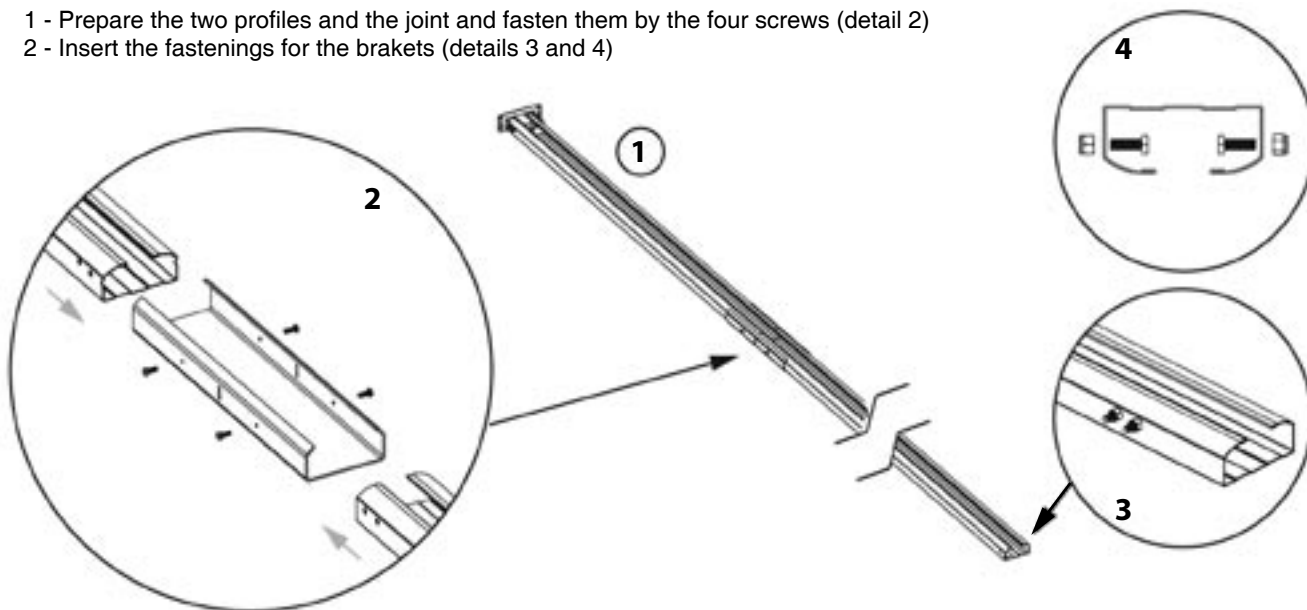

3 - Extend the belt and check that the unit is lined up, with the teeth facing inwards, then insert the downward side of the carriage (fig.6).

4 - Insert the "belt unit" into the guide, from the screw end until the motor support is restrained (fig.7).

5 - Insert the screw M8x70 into the bracket. Insert in this order the spring, the washer and the self-locking M8 nut (fig.8).

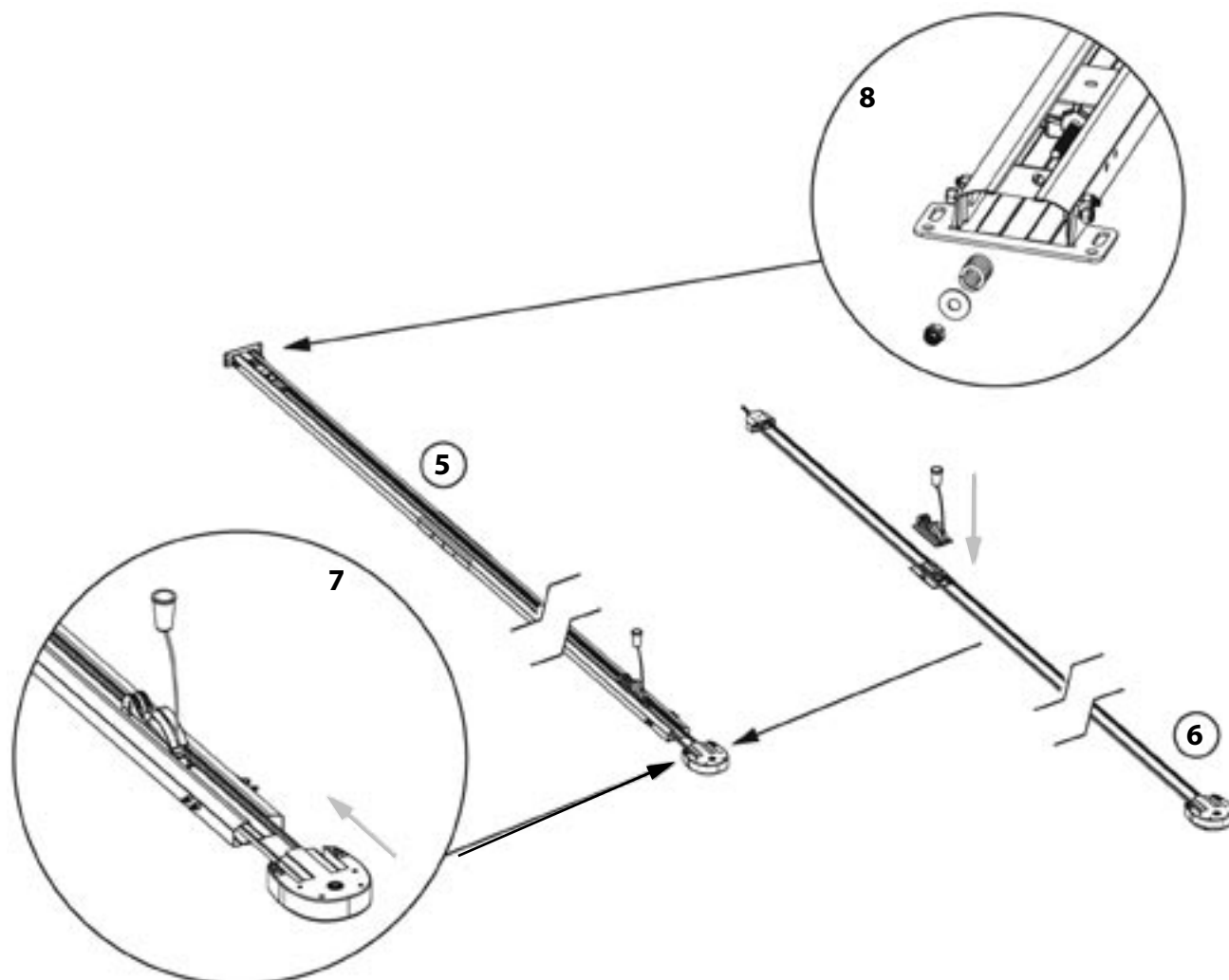

3C - FIXING THE BRACKET TO THE CARRIAGE ON "GRB3", "GRB23" AND "GRB4"

- 1 - Unscrew the M6 screws and the M6 nuts
- 2 - Insert the arm and the bracket and fix them (fig.9)

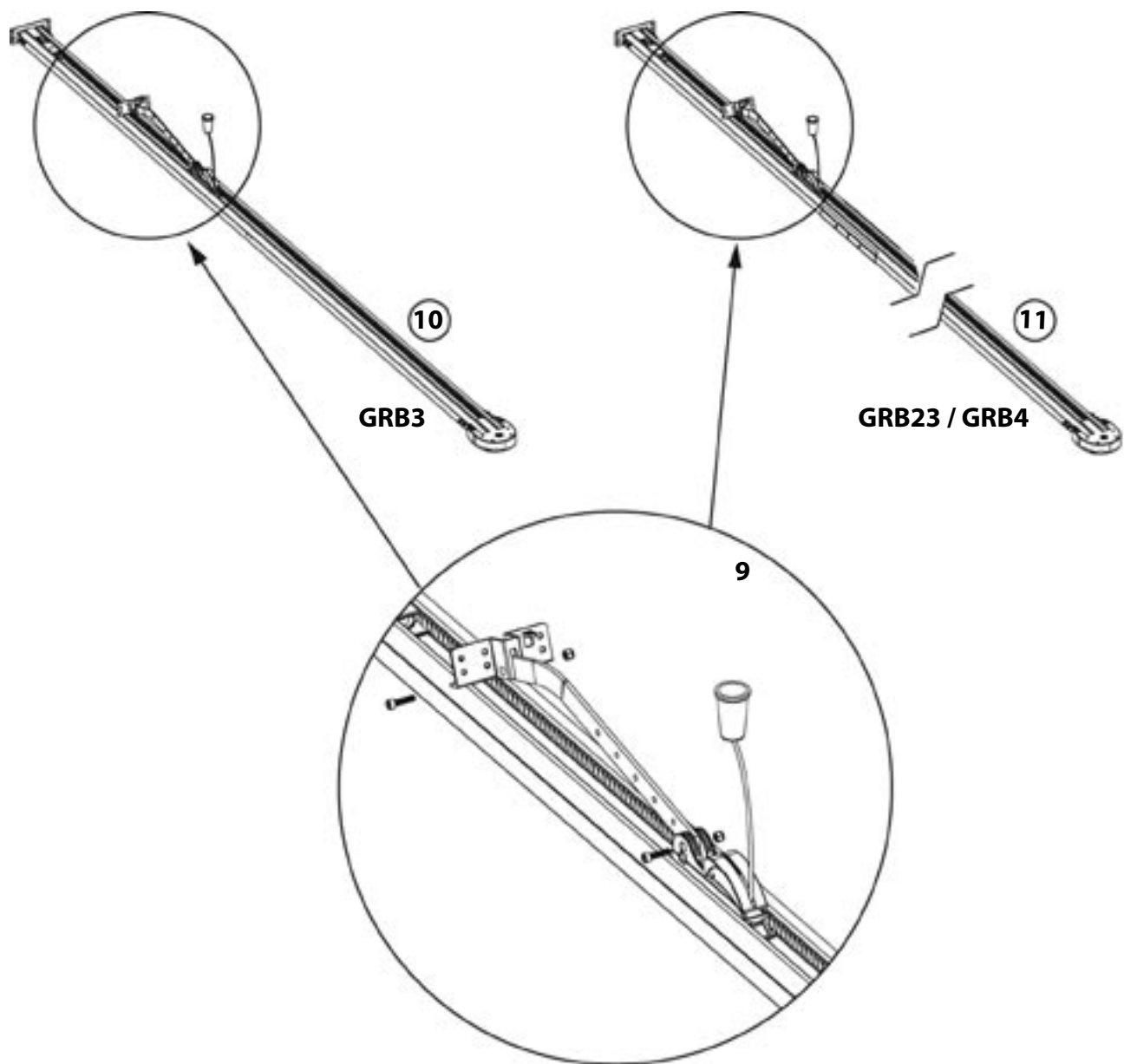

3D - BELT TENSIONING

1 - Tension the belt screwing the M8 nut until the complete compression of the spring (fig.12 and 13).

⚠ If the belt is tensioned after the door installation, the automation must be set on manual functioning

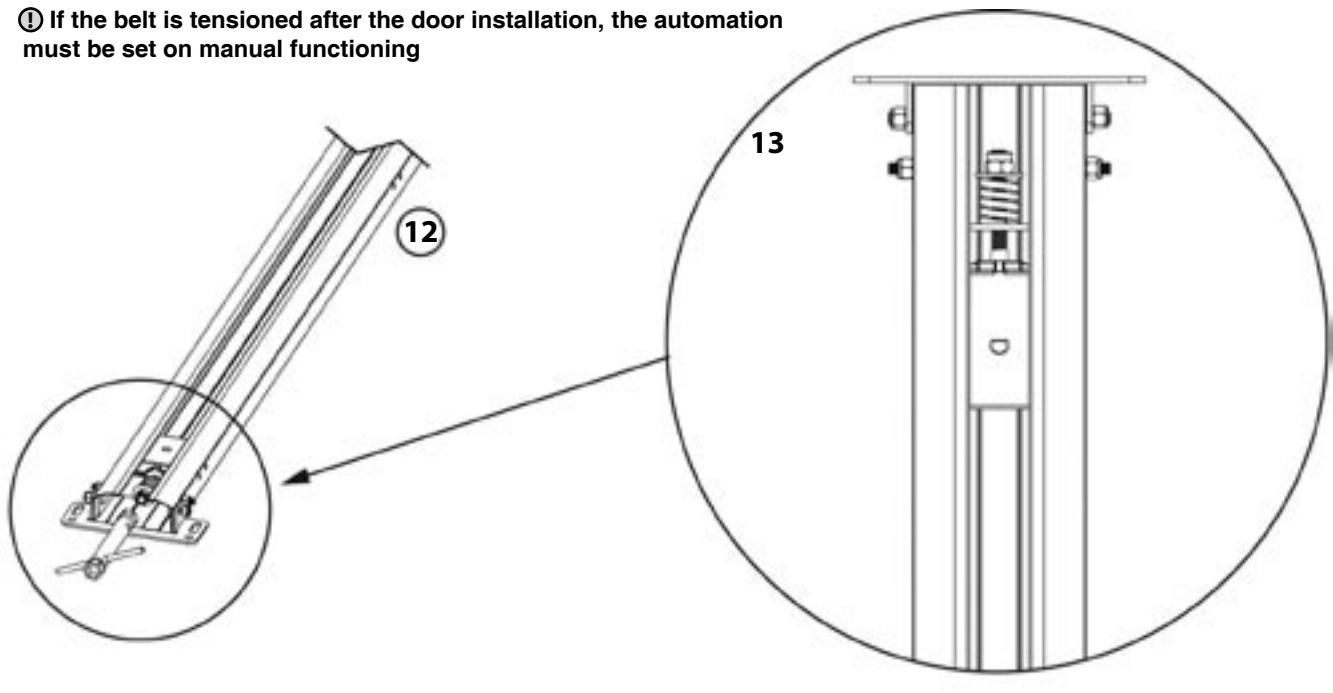

3E - FIXING THE GEAR MOTOR TO THE GUIDE

1- Put the carriage in the middle of the rail (see picture 10 and 11)

2 - Choose the side of the motor and fix it to the support (fig.14).

3 - If the motor is fixed in position 1 screw the 6 screws 6.3mm x 50

If the motor is fixed in position 2 don't screw the screw in picture 15

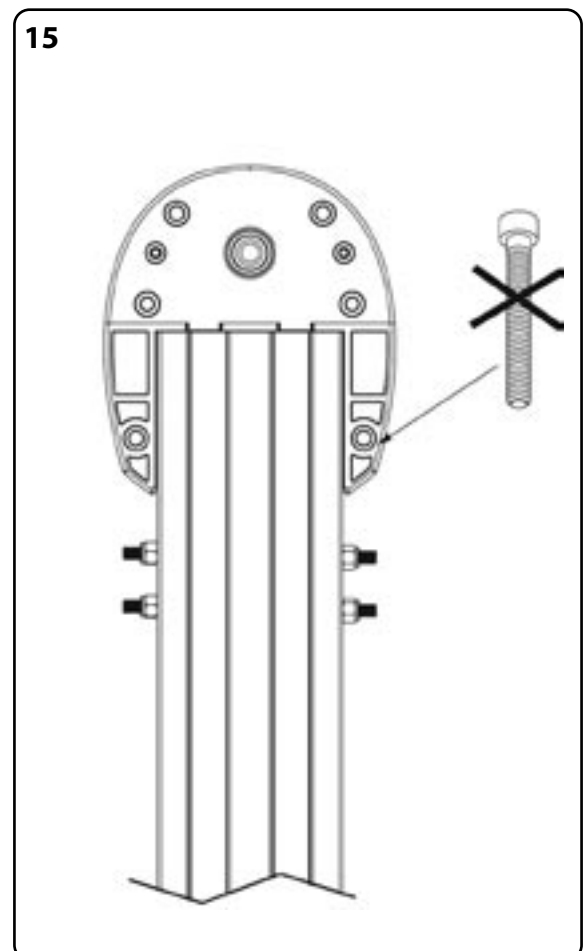
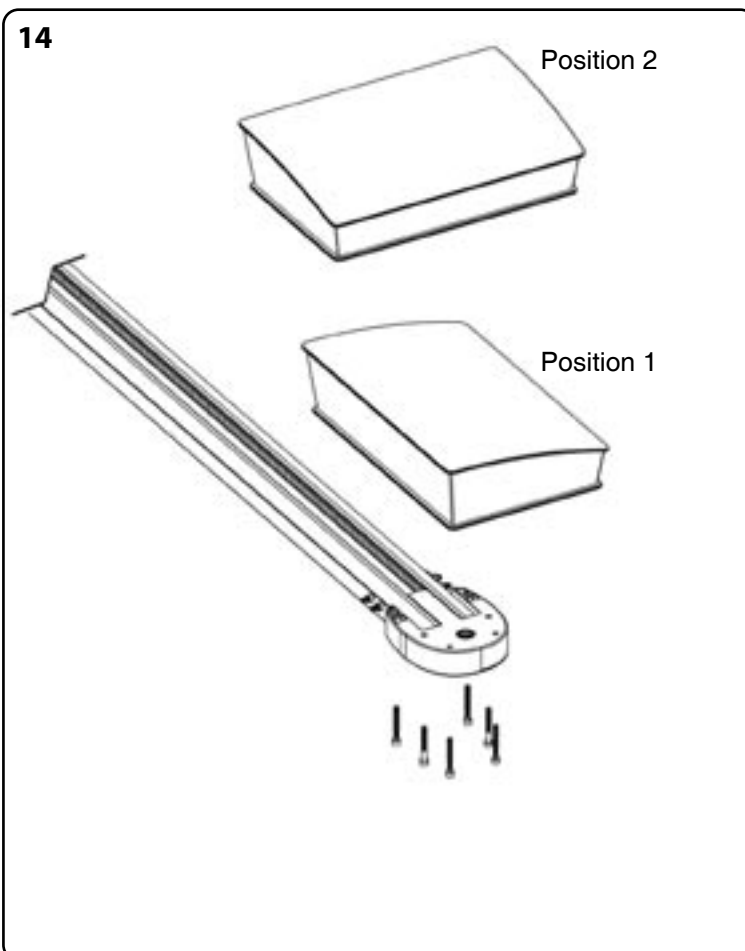

3F - FIXING THE RAIL

1 - Considering the installation limits (paragraph 2) and the chart in picture 18 fix it above the door, centrally to the door and with the bracket "O" perfectly level (fig.16).

Where the installation site allows, the possibility exists to fix the guide directly onto the ceiling, turning the bracket (fig.17).

2 - Unscrew the M6 nut (P) and anchor the fastening brackets to the ceiling above the guide verifying they are perpendicular to the profile (fig.20). For the choice of the holes, see the chart in picture 18

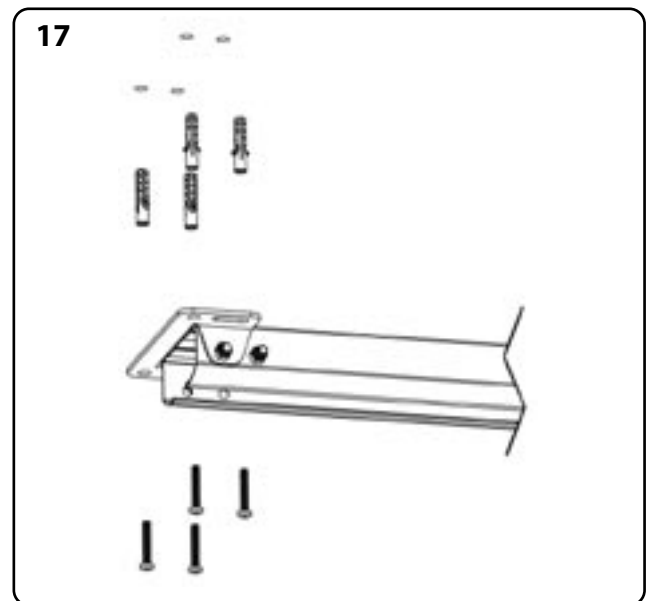
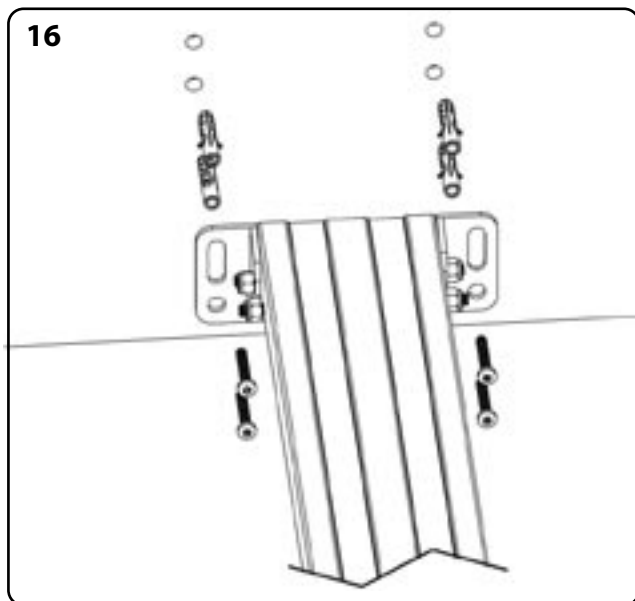

18 Ceiling height (H) (fig.19)	Bracket hole	
0 cm	1	
4 cm	2	
8 cm	3	
12 cm	4	
16 cm	5	
20 cm	6	
24 cm	7	
28 cm	8	
32 cm	9	
36 cm	10	
40 cm	11	

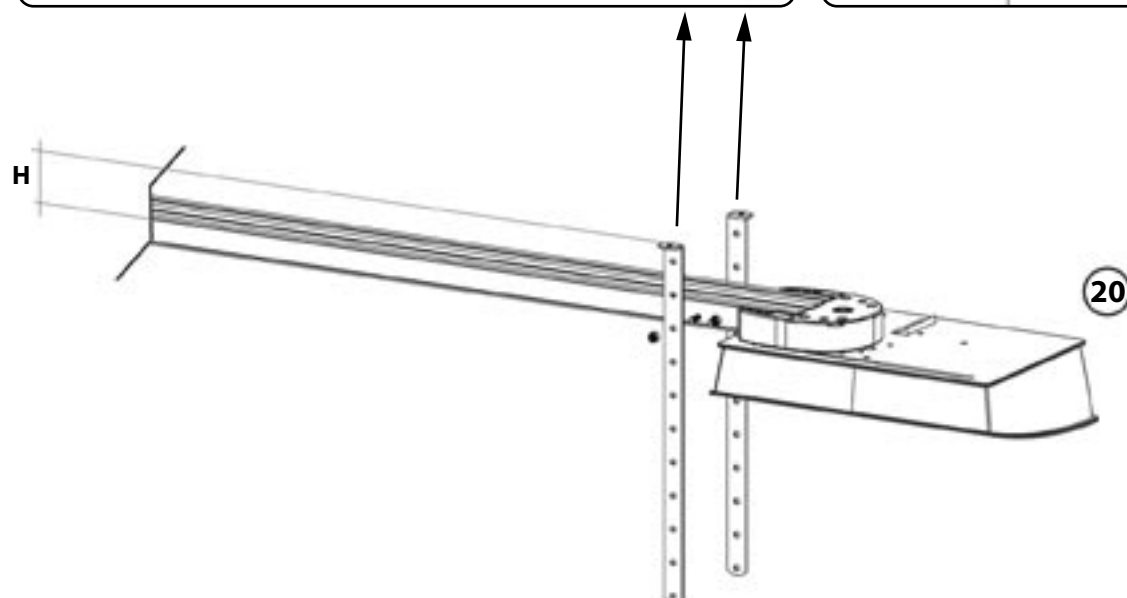
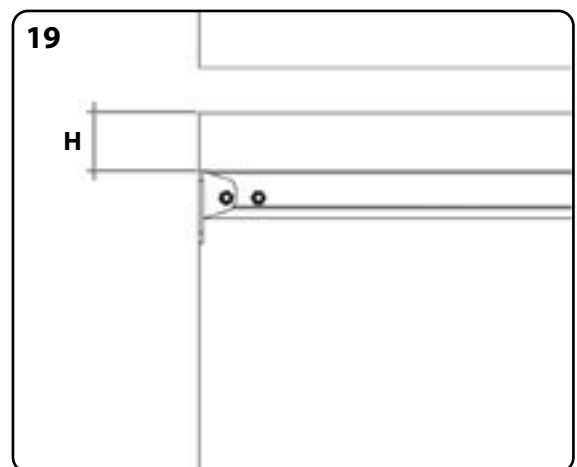

3G - FIXING THE DOOR TO THE BRACKET

Set the automation to manual operation (see the paragraph "manual manoeuvre" at the end of the manual instruction) and then drag the carriage to the door. Fix the bracket to the door making sure the two surfaces mate perfectly (fig.21).

⚠ Please verify it is firmly fastened, opening and closing the door manually.

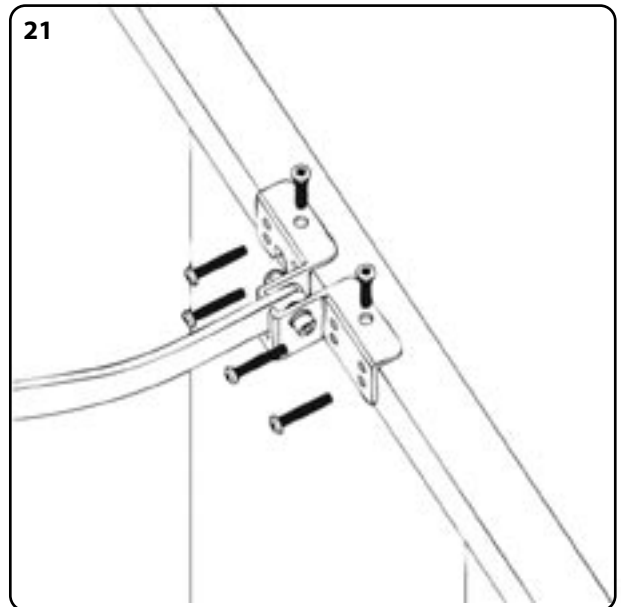

3H - ADJUSTING THE END OF STROKE

With the automation set on manual operation, fully close the door, loosen the catch screw (R) and join the catch itself to the drive carriage. Then tighten the screw firmly (fig.22). Repeat the operation with the door fully open (fig.23).

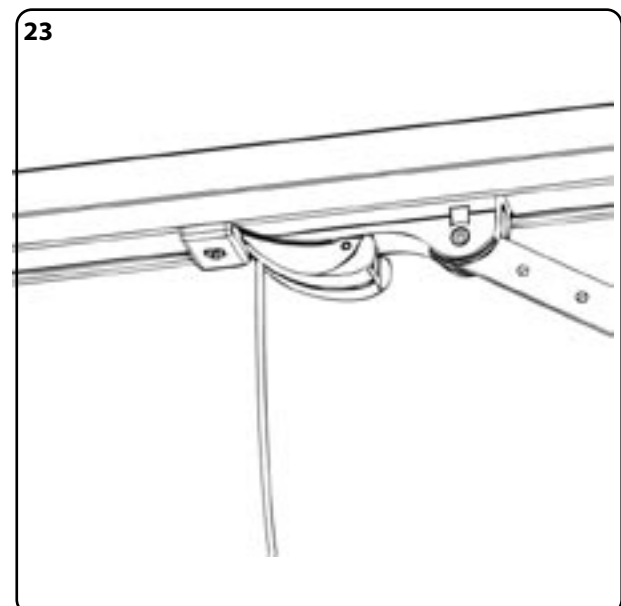
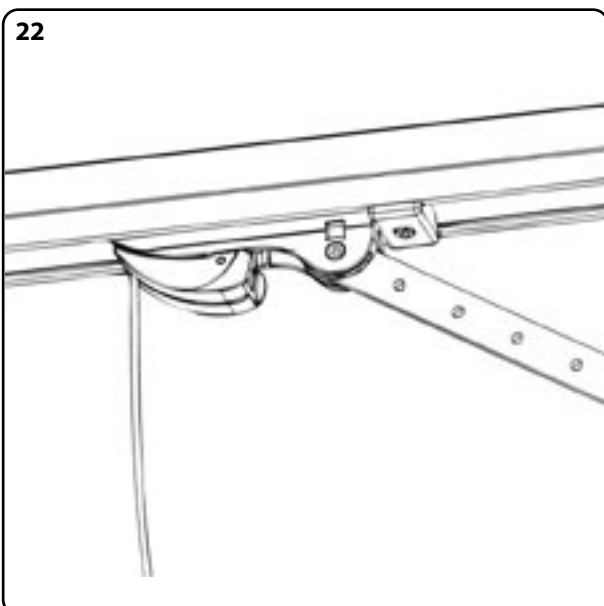

⚠ During the standard functioning the carriage will stop about one centimeter before the opening mechanical stop to reduce the mechanical stress

4 - CONTROL UNIT

4A - STARTING MODALITY

The control unit has been designed to manage 24V sectional door automations.

To start the system it is necessary to:

- 1- Connect the power supply, the motors, and the accessories as indicated in the 5C paragraph.
- 2- Set the dip-switches (paragraph 7A) and the trimmers (paragraph 7B) depending on the wanted functioning and on the conditions of the system.
- 3- Perform the standard programming procedure (paragraph 9B) or the professional programming procedure (paragraph 9D) to recognize the starting point and the end point of the travel and, in case, perform a radiotransmitter programming procedure (paragraph 9D)
- 4- Perform the checks reported on paragraph 9C (warning before starting).

ⓘ If the control unit keeps on having problems after these steps, see paragraph 13 “Signaling led”, to identify possible anomalies, and paragraph 17 “inconvenient and remedy” to try to eliminate them.

4B - PRESETS

If you perform the standard programming procedure, and there are no modifications on the trimmer regulation and on dip switches, the control unit will act as follows:

- The safety devices in closing, connected to “PHO1” contact (terminal 16), will intervene only in closing, inverting the motion.
- Pause time before automatic reclosing equal to 120 seconds.
- Pedestrian opening procedure is disabled.
- The slowdowns are set to the final 15% of the travel.
- Operation mode set to STEP by STEP with automatic reclosing

5 - ELECTRIC CONNECTIONS

5A - CABLES SECTION

To access to the control unit it is necessary to open the cover unscrewing the screw (fig.24). Make the cable connection as shown in the following drawing and insert the cables on the hole using the cable bushing (fig 25).

- The control unit must be powered (by its external fuse box terminal), through a cable which must be at least 3x1.5 mm² wide. If the distance between the control unit and the grounding system is more than 30m it is necessary to install an electric discharger near to the control unit.
- The cables which will be used for the low-tension must be at least 0.25 mm² wide.
- If the length between the control unit and the grounding system is more than 30 m, it is necessary to use screen cables. If the distance increases, it is necessary to increase also the section of the wires, to avoid current loss.
- Do not link the cables in underground box, or in inside the pipes.
- Use only RG58 wires to connect external antennas (it can be provided as accessory with included power cables).

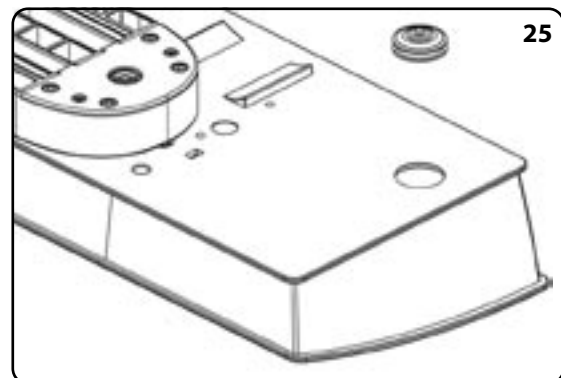
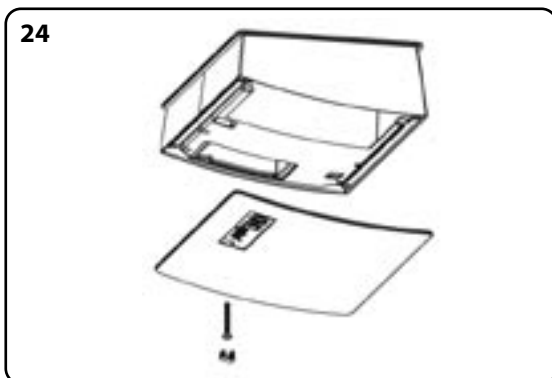

5B - NOTE FOR THE CONNECTION

- Every contact which will be connected to the control unit must be free contact.
- If there are no connected devices on the terminal 3 (normally closed input “PHO1”) or terminal 6 (“STOP”), the concerning inputs must be bridged.
- If there are connected devices on the terminal 3 (normally closed input “PHO1”) or terminal 6 (“STOP”), the concerning inputs must not be bridged.
- If there are more than 1 device connected to the normally closed input “PHO1” (terminal 3) and “STOP” (terminal 6), they must be connected in series (see paragraphs 14B and 15A).
- If there are more than 1 device connected to the normally open input “STR” (terminal 4) they must be connected in parallel (see paragraphs 14A).
- If an external antenna is connected, the built-in wire in the terminal 10 must be removed.

5C - CONNECTION DRAWING

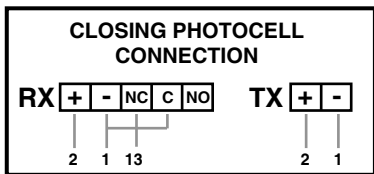
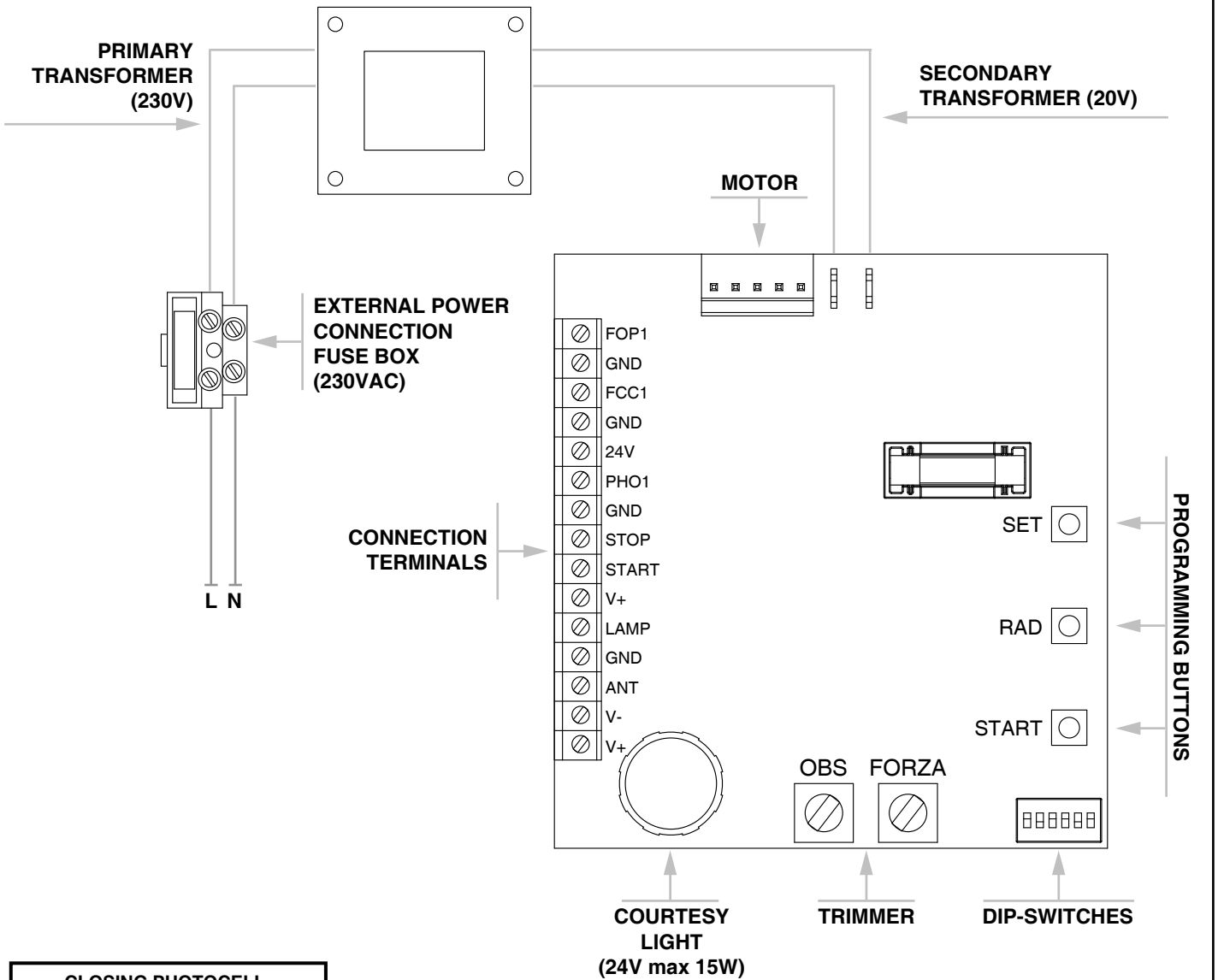

- Not in use
- 1. Terminals 2 **COMMON**
- 2. + **PHOTOCELLS** (24Vdc)
- 3. Safety devices in closing contact **PHO1**
- 4. Terminal 4 - 6 **COMMON**
- 5. **STOP** contact
- 6. **START** contact
- 7. + **FLASHING LAMP** (24Vdc max 15W)
- 8. **FLASHING LAMP** negative
- 9. **ANTENNA** sock
- 10. **ANTENNA** signal

Not in use

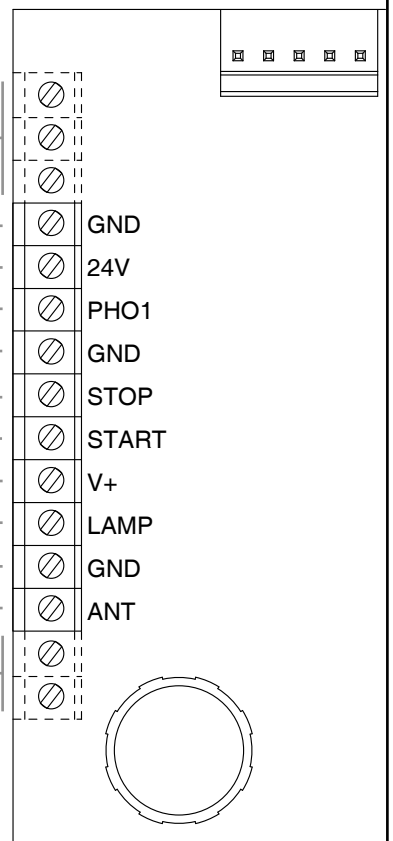

6 - RADIOTRANSMITTERS PROGRAMMING PROCEDURE

6A - START CHANNEL PROGRAMMING PROCEDURE

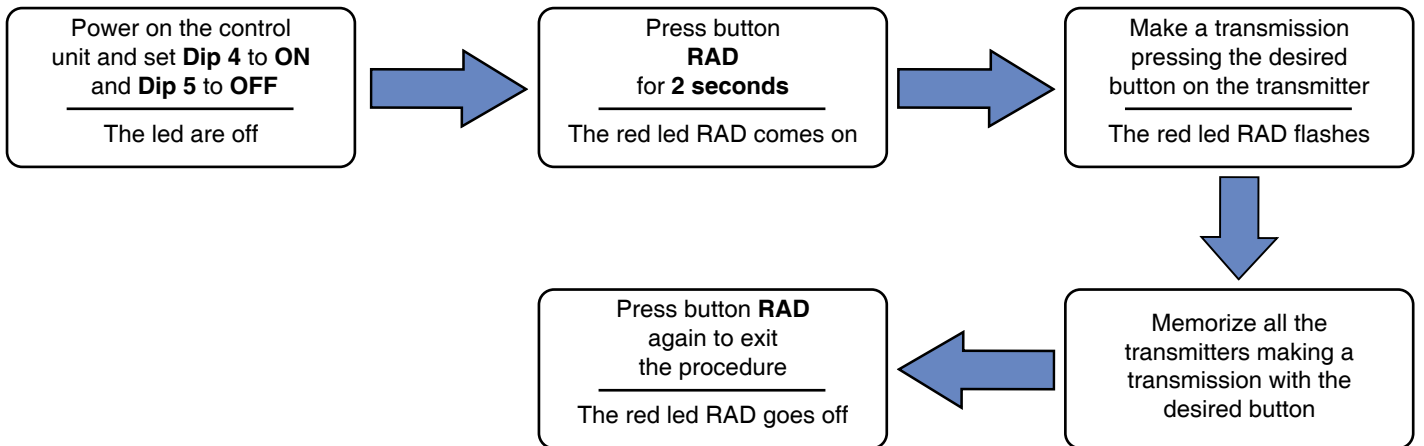

ⓘ The programming procedure terminates automatically in any case 10 seconds after the last transmission.

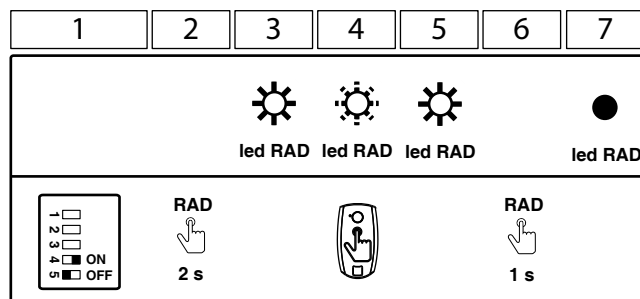

“MEMO PROG” (For the symbols, see paragraph 18)

6B - PROGRAMMING THE CHANNEL FOR ACTIVATING THE COURTESY LIGHT

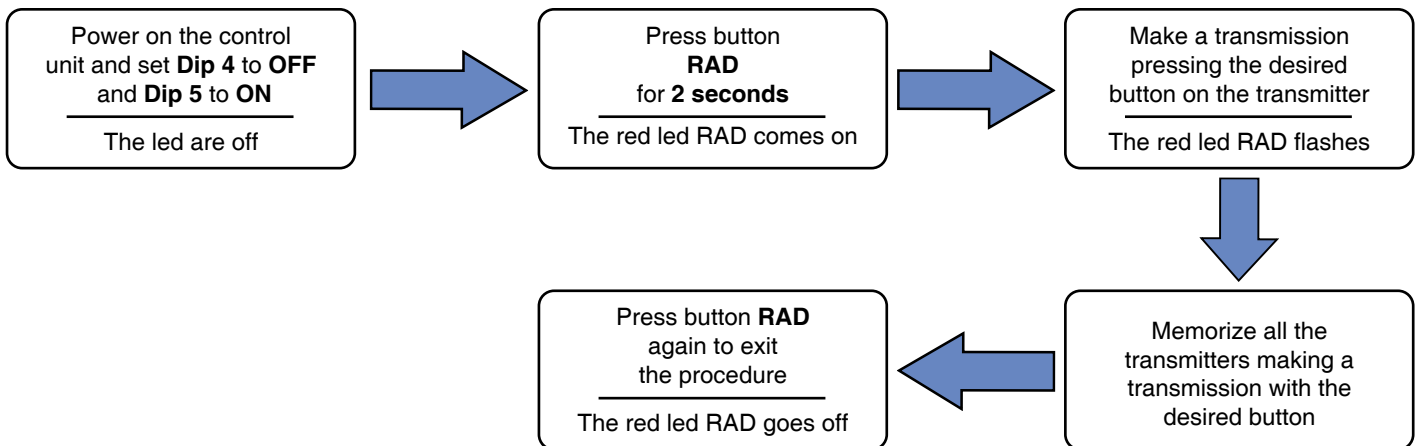

ⓘ The programming procedure terminates automatically in any case 10 seconds after the last transmission.

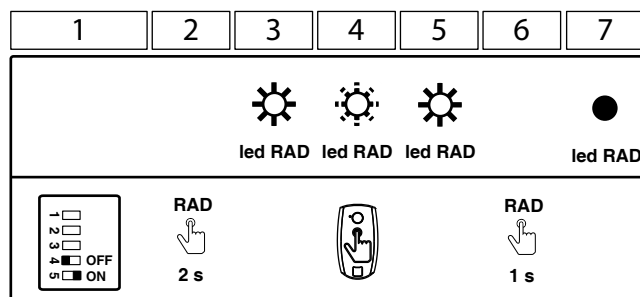

“MEMO PROG” (For the symbols, see paragraph 18)

6D - DELETING ALL THE CODES

Using this procedure the installer can delete all the previously programmed radio remote controls from the memory.

Hold down button
RAD for
3 seconds.
The red led RAD begins to flash rapidly

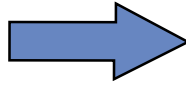

Press button **RAD**
again within 6 seconds to
confirm the deletion
The red LED blinks fast,
then it turns off

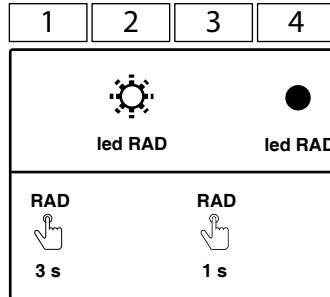

“MEMO PROG” (For the symbols, see paragraph 18)

7 - CONTROL UNIT SETTING

7A - DIP-SWITCHES SETTINGS

DIP	DIP STATUS	FUNCTIONING
1	OFF	Operation safeties for pedestrian access
	ON	Not active safeties in opening
2 - 3	OFF - OFF	Dead man's switch mode
	OFF - ON	Automatic closing mode
	ON - OFF	Step by step mode (open \ stop \ close \ stop)
	ON - ON	Step by step mode with automatic closing mode
4 - 5	OFF - OFF	No programming radio
	OFF - ON	Courtesy light radio channel programming procedure
	ON - OFF	START radio channel programming procedure
	ON - ON	No programming radio

ⓘ In “dead man” mode the run set and the radio programming are disabled

7B - TRIMMER

ⓘ A variation on the setting of “FORZA” trimmer (power/speed) requires the repetition of the learning procedure

Power/Speed (“FORZA” trimmer):

Regulation from 50% to 100% of the power to the motors.
This parameter will also weigh on the manoeuvre speed.



FORZA

Obstacle sensitivity (“OBS” trimmer):

Regulation of intervention time from 0.1 to 3 seconds. The lower the trimmer is regulated, earlier the central will stop the automation in case of impact of the wing against an obstacle.



OBS

8 - OPERATION MODES

8A - DIP 2 OFF \ DIP 3 OFF - DEAD MAN'S SWITCH MODE

Hold down the START button located on the electronic board, the control unit opens the door until the end of opening stroke is reached or the button is released. Hold down the RAD button located on the electronic board, the control unit closes the door until the end of closing stroke is reached or the button is released.

ⓘ In dead man mode the run set and the radio programming are disabled

ⓘ The dead-man mode can be used only during the programming

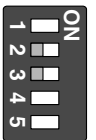

8B - DIP 2 OFF \ DIP 3 ON - TIME AUTOMATIC CLOSING MODE

In this mode, if a command is given via radio or through the “START” input, the control unit:

- when the automation is closed: it executes a total opening
- during an opening operation: the movement of opening continues
- when the automation is open: it remains opened and it reduces to zero the time of pause
- during a closing operation: it reopens totally

The closing happens after the time of pause (default 90 s, customizable following the procedure in paragraph 10).

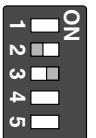

8C - DIP 2 ON \ DIP 3 OFF - STEP BY STEP MODE

In this mode, if a command is given via radio or through the “START” input, the control unit:

- when the automation is closed: it executes the total opening
- during an opening: it executes the stop
- when the automation is open: it executes the closing
- during a closing operation: it executes the stop

The automatic closing is disabled.

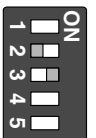

8D - DIP 2 ON \ DIP 3 ON - STEP BY STEP MODE WITH AUTOMATIC CLOSING

In this mode, if a command is given via radio or through the “START” input, the control unit:

- when the automation is closed: it executes the total opening
- during an opening: it executes the stop
- when the automation is open: it executes the closing
- during a closing operation: it executes the stop

The closing happens after the time of pause (default 90 s, customizable following the procedure in paragraph 10).

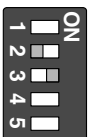

9 - TRAVEL PROGRAMMING PROCEDURE

9A - PROGRAMMING WARNINGS

It is necessary to perform the learning procedure to program the travel (see paragraph 9B for the standard procedure, or paragraph 9D for the professional procedure).

There is also a learning procedure for the pedestrian opening (see paragraph 11D, it is not necessary).

The control unit is programmed by the buttons, and the control unit status is shown during the programming procedure by the yellow led "SET". When the control unit begins the programming procedure, the yellow led "SET" switches on. It stays on until the end of the programming procedure, or until an anticipated quit (by pushing SET and RAD simultaneously), which stops the programming procedure and the motors.

To having a better travel regulation, it could be necessary to intervene during the programming procedure, at the end of opening and closing cycles (points 5, 6, 7 for the standard programming procedure, and points 5, 9B, 12B for the professional programming procedure), by pushing the SET button to stop them at the end of the opening/closing.

ⓘ During the programming procedure, every safety device is disabled, to let the installer moving through their range

9B - STANDARD LEARNING PROCEDURE

The installer set the manoeuvre time and the workforce of the motors by this procedure.

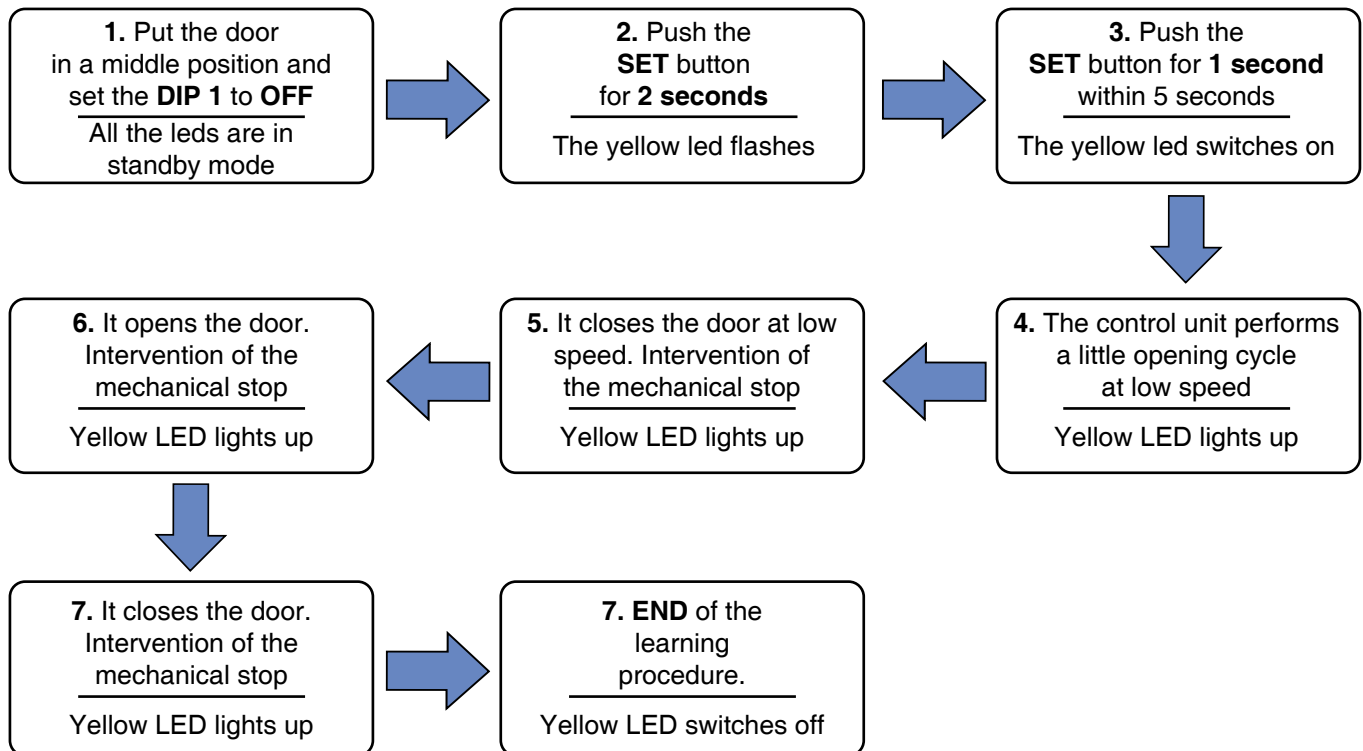

ⓘ The slowings down are set to the 15% of the total motion, both in opening and in closing.

ⓘ During the standard functioning the carriage will stop about one centimeter before the opening mechanical stop to reduce the mechanical stress

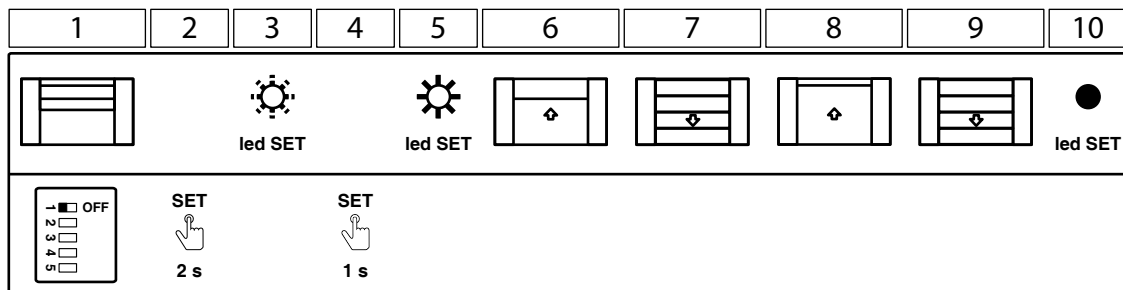

“MEMO PROG” (For the symbols, see paragraph 18)

9C - WARNINGS BEFORE STARTING

After the programming procedure verify that:

- The motor shut down a few seconds after the end of the programming procedure.
- The control unit respond to the inputs received by wire: “START” and “STOP” (terminal 14).
- The control unit respond to the inputs received by transmitter.
- The safety devices connected to “PHO1” intervene while the gate is closing and prevent the closing when the gate is opened. If the DIP 1 is set to OFF, prevent the opening when the gate is closed.

9D - PROFESSIONAL LEARNING PROCEDURE

The installer can set the beginning point of the slowdown through this procedure. The beginning point is customizable in opening and closing. The installer can set the beginning point of the slowdown through this procedure. The beginning point is customizable in opening and closing.

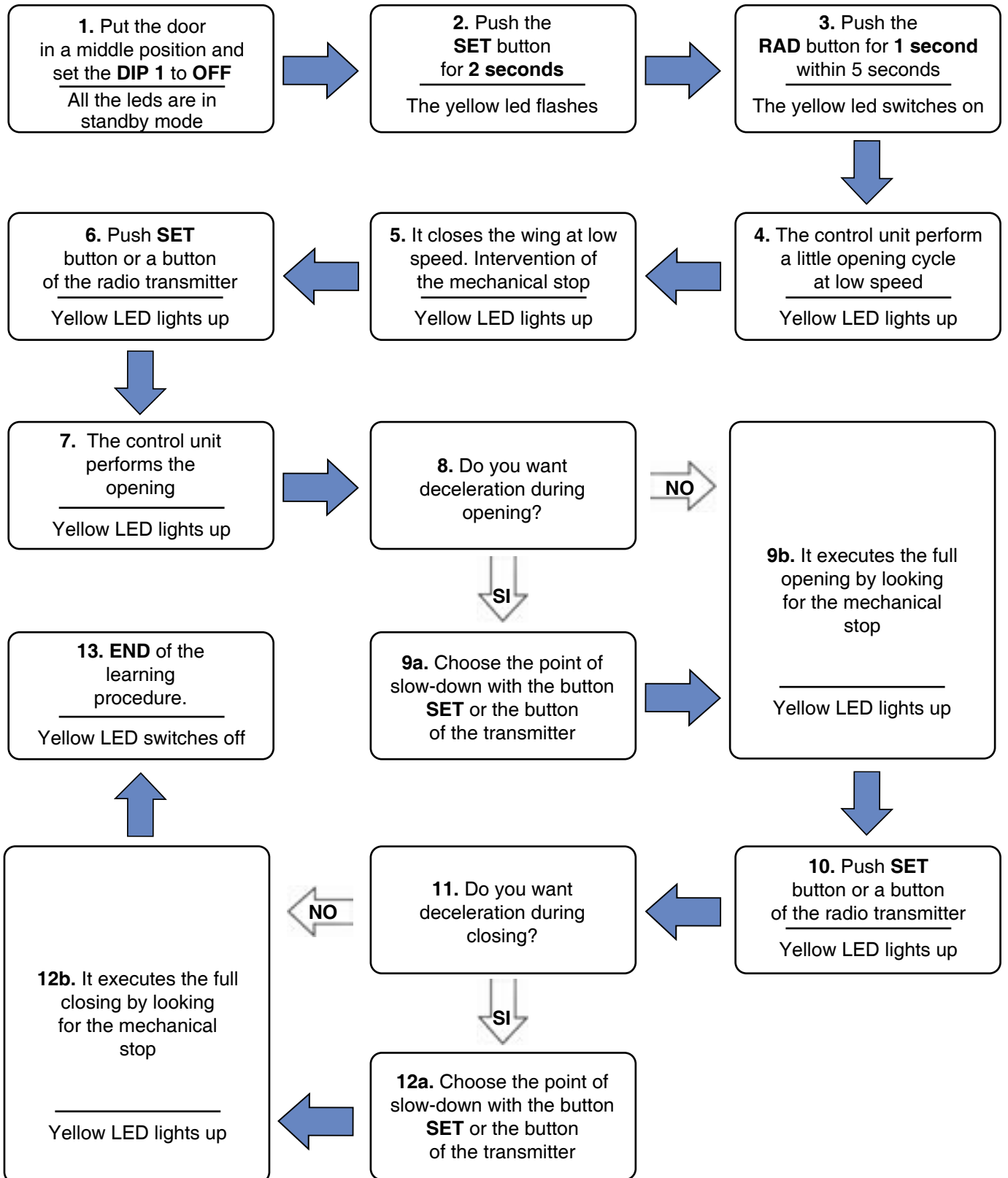

① After the programming procedure, see also paragraph 6C for the starting.

① During the standard functioning the carriage will stop about one centimeter before the opening mechanical stop to reduce the mechanical stress

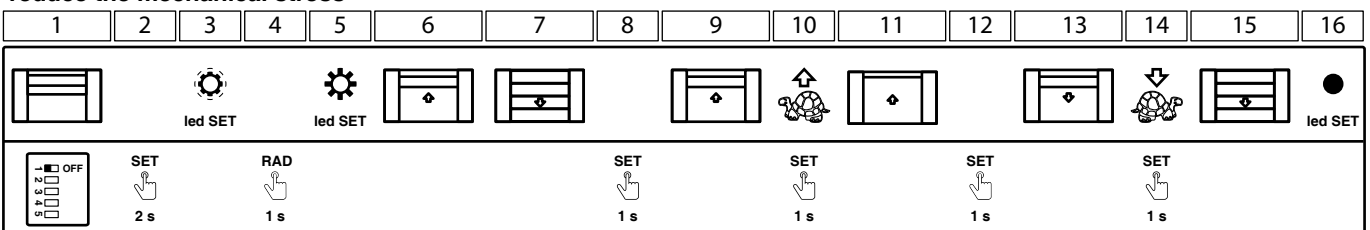

10 - PAUSE PROGRAMMATION

10A - PAUSE TIME PROCEDURE

By following this procedure, the operator can set the pause time that occurs before the automatic closing

① Both DIP 2 and DIP 3 must be set in ON. Alternatively, DIP 2 must be set in ON and DIP 3 in OFF (see paragraph 7A).

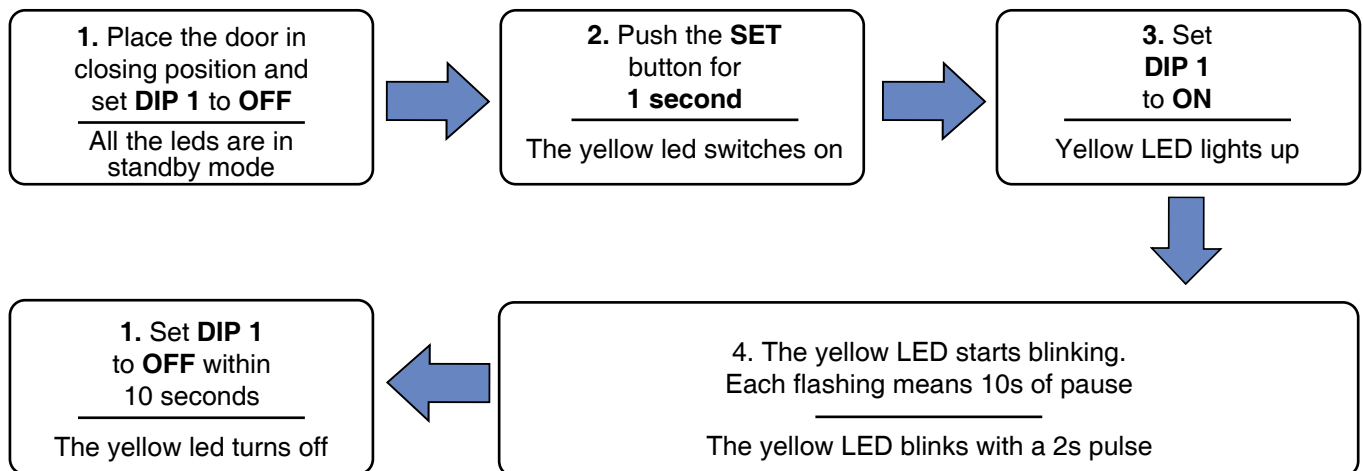

⚠ If the procedure is interrupted, the controller quits the programming mode and none modification is set.

⚠ The maximum pause is 120s. The yellow LED will blink 12 times, then will blink one more time (13th blink) and will wait for 10s until the operator quit the programming mode (DIP selection).

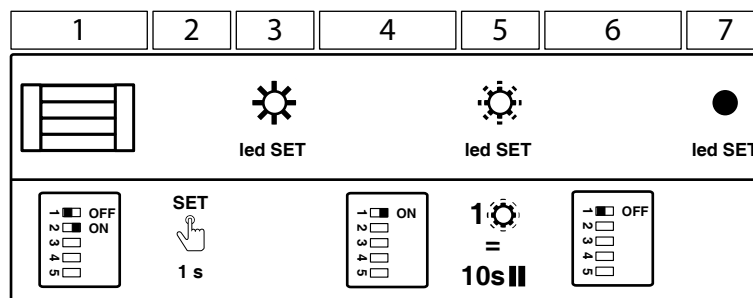

“MEMO PROG” (For the symbols, see paragraph 18)

12 - TRIMMER

12A - TRIMMER FORZA

Use the "FORZA" trimmer to adjust the voltage with which the motor is powered during operation, thus adjusting its speed. This is settable between 50% and 100% of the maximum force and can be increased by turning the trimmer clockwise. Thus if the trimmer is set on the minimum then the speed is equal to about 50%, if adjusted in an intermediate position it is equal to 75%, while at the maximum the speed will be the largest obtainable.

ⓘ A variation of the "FORZA" trimmer requires the repetition of the learning procedure since the operation times, and thus the moments in which to start the slow-down, vary.

12B - TRIMMER OBS

The "OBS" trimmer is used to adjust both the intervention delay after detection of an obstruction and the opposing force to be used by the automation. This function is useful to overcome any critical points of the automation where, for a brief time interval, there is greater power absorption by the motor.

13 - SIGNALLING LED

The leds show the state of the control unit and of some of the connected accessories. Normally, when the control unit is powered and working, the red PH led and the red ST led should be on. Otherwise, verify the connected accessories, or the bridges which substitute them.

13A - YELLOW LED SET

- it is fixed on during the programming procedure (standard, professional or pedestrian opening)
- it flashes to indicate that it is possible to enter the programming procedure (standard, professional or pedestrian opening)
- it flashes at double speed if it is required a programmation
- is switched off when the control unit functions normally

13B - RED LED RAD

- is fixed on during when radio codes are being memorized
- flashes rapidly during the cancellation of radio codes
- it flashes for 1 sec of a reception a radio code
- is switched off when the control unit is functioning normally
- flashes rapidly if the photocells and stop contacts are open

13C - YELLOW LED SET AND RED LED RAD

- are on for 3 seconds in case of error on reading of the encoder

14 - CABLE COMMANDS CONNECTABLE

14A - STARTING COMMAND CONNECTION

In the "START" input (terminals 4, 6) it is possible to connect a normally open contact (for example, key selectors, or switches) to manage the automation. The commands can be set by dip switches 4, 5. There are 2 micro switches in the selectors; each one has its own function. Picture 1 shows the terminals in which is possible to connect a micro switch for the starting command. A selector can also issue a starting command with both the contacts connected in parallel (see picture 2).

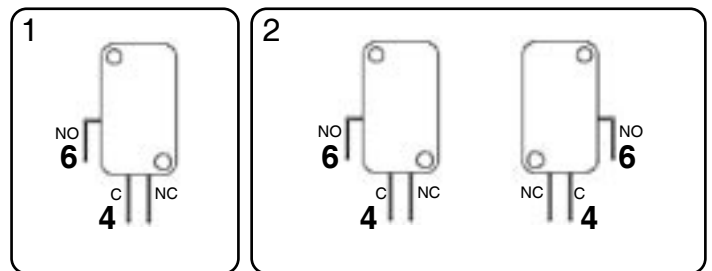

- ⓘ If there is more than one opening contact, they must be connected in parallel (see picture 2).
- ⓘ Keeping the opening contact closed ("START" terminal, for example with a relay), the control unit performs the opening, and the automation doesn't accept closing commands (neither automatic, nor by wire), as long as the contact will be opened again.

14B - STOP COMMAND CONNECTION

In the "STOP" input (terminals 4, 5), it is possible to connect a normally closed contact, to perform the immediate stop of every function. Picture 1 shows the terminals in which it is possible to connect a stop button. To restart the functions, it is necessary to deactivate the stop command.

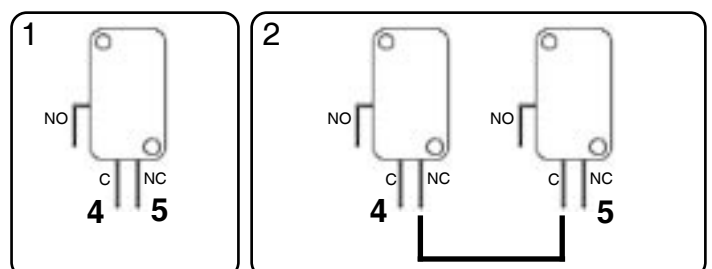

- ⓘ If there are more than one stop contacts, they must be connected in series (see picture 2).

15 - OPERATION OF THE SAFETY DEVICES

15A - CLOSING SAFETY DEVICES

It is possible to connect normally closed contact devices to the "PHO1" input (terminal 1, 4). These devices operate during opening and closing cycles depending on the setting of DIP1 "PHO2" (see paragraph 4A):

DIP1 SET TO ON (No action on opening):

- in **closing phase** an immediate inversion of the motion
- in **opening phase** they have no effect
- if the **access is closed** they have no effect
- if the **access is open** they inhibit the closing commands

DIP1 SET TO OFF (Pedestrian door, see fig.3):

- in **closing phase** an immediate inversion of the motion
- in **opening phase** they have no effect
- if the **access is closed** they inhibit the opening commands
- if the **access is open** they inhibit the closing commands

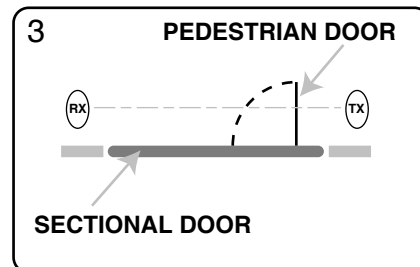
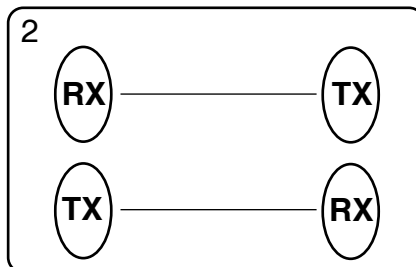
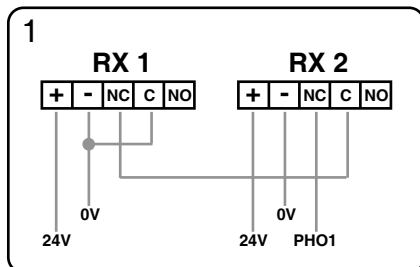

- ⓘ If there are more than one devices on this contact (PHO2), they must be connected in series (see picture 1).
- ⓘ If there are more than one photocellules, the receivers must be alternated (see picture 2)

15B - OBSTACLE DETECTION BY POWER ABSORPTION

Depending on the regulation of trimmer "OBS" (see paragraphs 7B, 12) the control unit could be more sensitive (and invert the motion more easily) in case of impact of a wing against an obstacle.

However, a too sensitive regulation of the trimmer, together with a worsening of the condition of the system caused by the passage of time, could cause unexpected interventions in the points where the motors absorb more current.

16 - OTHER CONNECTABLE ACCESSORIES

16A - FLASHING LAMP

It is possible to connect flashing light devices to the "LAMP" input (terminals 7, 8).

These devices turn on a second before the manoeuvre.

The power supply is intermittent, so you can connect a normal lamp.

- ⓘ The lamp must be 24 Vdc, and power rating must not be greater than 15W

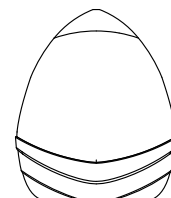

16B - ANTENNA

It is possible to connect a radio frequency antenna to the "ANT" (morsetti 9, 10). The control unit is provided with a pre-connected cable. In particular environmental conditions, it can be useful to connect an external antenna, to increase the transmitter range.

- ⓘ In case of connection of external antennas, it is necessary to remove the pre-connected cable.

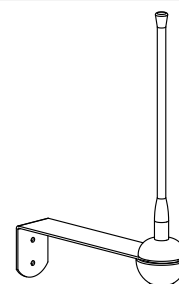

17 - INCONVENIENTS AND REMEDIES

THE AUTOMATION DOESN'T START

- Verify the presence of voltage in the terminals of the external fuse box
- Verify the fuse
- STOP contact open: check for possible STOP commands connected. If absent, jumper the input

THE AUTOMATION PERFORMS ONLY THE OPENING CYCLE

- The photocell is obstructed: check the correct positioning of the photocells and their range
- The photocell is absent: if there are no devices connected jumper the input
- A normally closed contact, or a defective contact, is connected on "STAR" input

THE AUTOMATION WORKS ONLY BY WIRE

- The radio transmitter hasn't been correctly programmed
- The battery of the transmitter are exhaust. Change them

THE AUTOMATION STARTS BUT, AT A CERTAIN POINT, IT INVERT THE TRAVEL

- Too low obstacle sensitivity. Increase the "OBS" trimmer
- Intervention of safety devices. If there are two pairs of photocells, they could see each other. Invert a receiver with its transmitter

THE AUTOMATION STARTS BUT, AT A CERTAIN POINT, IT STOPS

- Not enough power. Set "FORZA" trimmer at maximum level, and program the automation again.
- Perform a professional programming procedure and reduce at minimum (or remove) the slowdowns.

WHEN THE BOARD IS POWERED UP, BOTH THE LED ARE ON











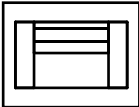
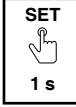

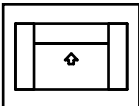
- Perform a programming procedure. Then try again

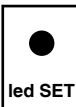
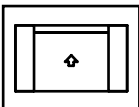
THE BELT OUT THE SLIDING GUIDE

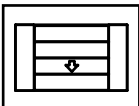
- Tighten the belt when the automation is unlocked (see Section 3C)

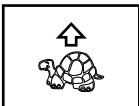
18 - MEANING OF THE SYMBOLS OF "MEMO PROG"

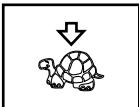
MEANING OF THE SYMBOLS

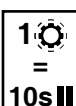
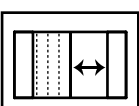
	The yellow LED (SET) blinks		Door on the middle of the total run		Press button SET for 1 second
	The yellow LED (SET) lights up		The door opens partially		Press button SET for 2 seconds
	The yellow LED (SET) is switched off		The door is full opened		Press button RAD for 1 second
	The red LED (RAD) blinks		The door is full closed		Press button RAD for 3 seconds
	The red LED (RAD) lights up		Set the suitable start for the slowing in opening		Press button START for 1 second
	The red LED (RAD) is switched off		Set the suitable start for the slowing in closing		Make a transmission pressing the desired button on the transmitter
	Each blink means 10s of pause		Set the suitable width for the pedestrian opening (partial opening)		

MANUAL MANOEUVRE

The release manoeuvre has been provided for manual opening of the door in case of a power cut or motor breakdown. In order to enable all types of use (for example the presence of an electric or outside lock) the handle has been designed to lock itself perpendicularly to the carriage, allowing the user to completely do away with door automation.

The gear motor can also be released from the outside installing the optional accessory "SBLO01" (external unlocking system to be applied on handle lock) or "SBLO 500" (external unlocking system to be applied with an hole in the door).

The two manual operating modes are:

Mode 1

The user that exits from the garage can close the gate and re-enter without having to repeat the release operation. The automation release must be guaranteed by an external blocking system (a lock, for example).

INSTRUCTIONS:

- Pull the release cord downwards as illustrated in figure 1 until the handle perpendicular to the guide is blocked, unhooking the lower driving carriage.
- Move the gate manually

Mode 2

The user that exits the garage, making use of the reconnection of the automation during the manual closing operation, obtains the recoupling of the carriages and thus the blocking of the gate.

INSTRUCTIONS:

- Pull the release cord downwards as illustrated in figure 1 until the handle perpendicular to the guide is blocked
- Move the door manually
- Return the handle to the original position (figure 2)

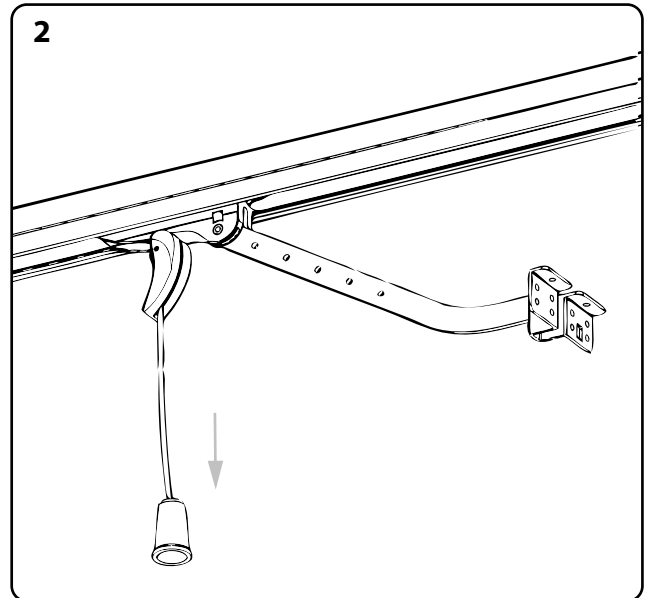
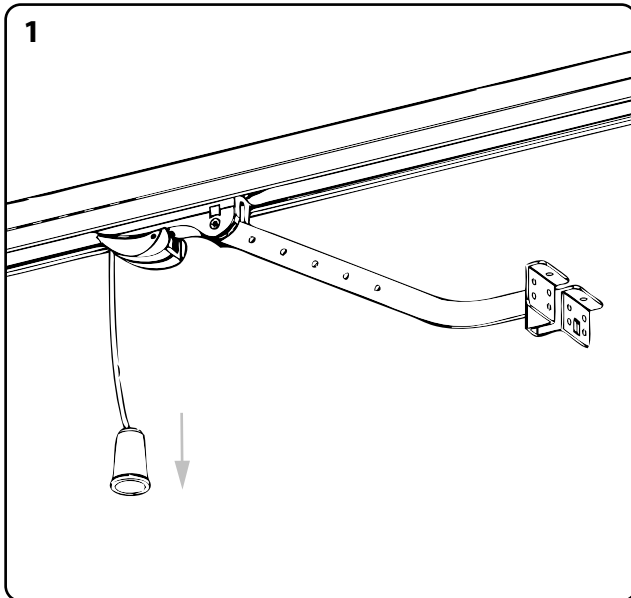

⚠ During manual operation use only the door for opening and closing, thus avoiding strain on the carriage by pulling the release cord.

COURTESY LIGHT REPLACEMENT

- Open the cover as shown in Figure 3
- Remove the lamp if not working and insert a new 24V 15W max the same size

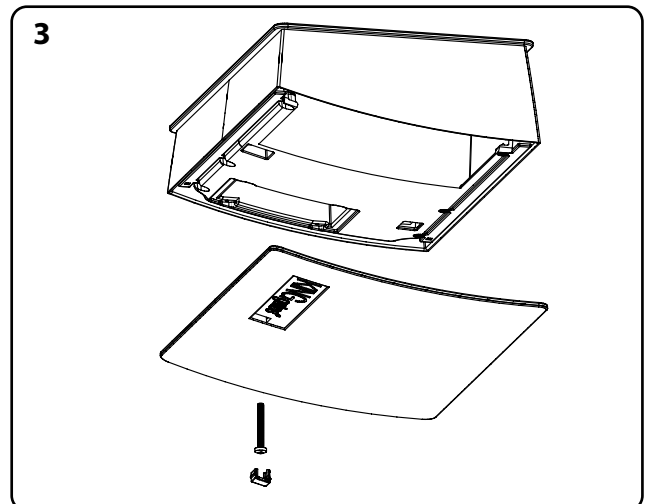

DICHIARAZIONE CE DI CONFORMITÀ DECLARATION OF CONFORMITY

Il sottoscritto Antonioli Mario, legale rappresentante della ditta Antonioli Mario & C. sas, dichiara che il prodotto:

The undersigned Mario Antonioli, general manager of the following producer, declares that the product:

NOME PRODUTTORE: KINGgates di Antonioli Mario & C. sas

Manufacturer's name:

INDIRIZZO: Via A. Malignani 42, 33077 Sacile (PN) Italy

Address:

TIPO:

Centrale elettronica per 1 motore 24Vdc

Type:

Control unit for 1 24Vdc motors

MODELLO:

Star D124 S, Star D124 KG

Model:

Risulta conforme a quanto previsto dalle seguenti direttive europee:

Satisfies the essential requirements of the following Directives:

DIRETTIVA BASSA TENSIONE

Low Voltage Directive

2006/95/CE

EN60335-1

EN60335-2-103

DIRETTIVA MACCHINE

Machinery Directive

2006/42/CE

COMPATIBILITÀ ELETTROMAGNETICA

Electromagnetic Compatibility

2004/108/EC, 92/31/EEC, 93/68/EEC, 91/263/EEC

EN61000-6-1

EN61000-6-3

Come previsto dalla direttiva 2006/42/CE si avverte che non è consentita la messa in servizio del prodotto sopra indicato finché la macchina, in cui il prodotto è incorporato, non sia stata identificata e dichiarata conforme alla direttiva 2006/42/CE.

As specified in the directive 98/37/CEE, use of the product specified above is not admitted until the machine on which it is mounted has been identified and declared as conforming to the directive 98/37/CEE.

Sacile, 18 Maggio 2011

Sacile, 18 May 2011

Il legale rappresentante

Managing Director

Antonioli Mario

INSTALLER REFERENCE

COMPANY:

PLACE:

PROVINCE:

TELEPHONE NUMBER:

CONTACT PERSON:

STAMP

PRODUCER REFERENCE



KINGgates - Brand of Antonioli Mario & C. s a s

Via A. Malignani, 42 - 33077 Sacile (PN) ITALY

Tel. +39 0434 737082 - Fax +39 0434 783382

e-mail: info@king-gates.com web: www.king-gates.com