

TR10C017 RE / 07.2008

Instructions for Fitting, Operating and Maintenance

Garage Door Operator

Instructions de montage, d'utilisation et d'entretien

Motorisation pour porte de garage

English.....4
 Français.....16

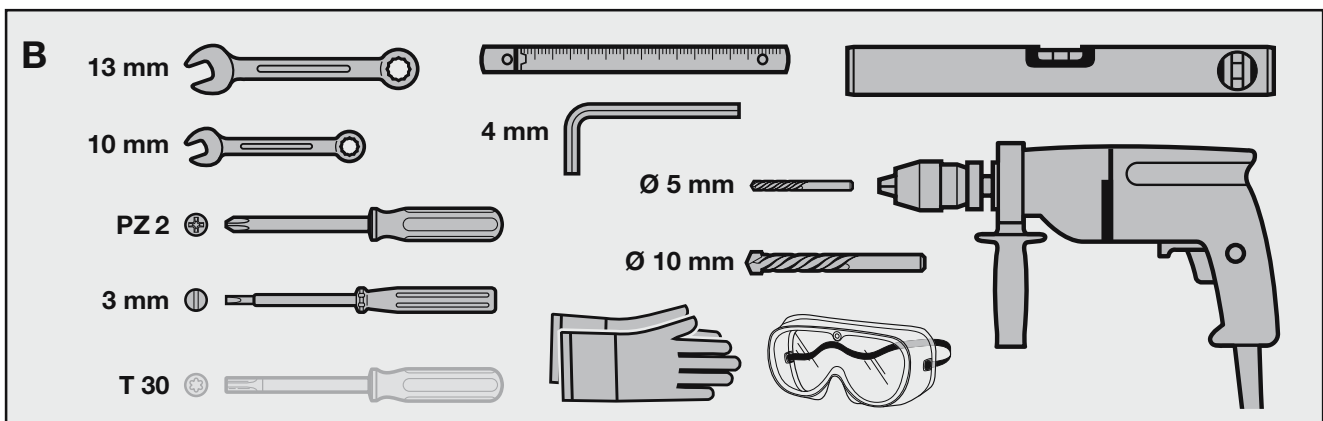
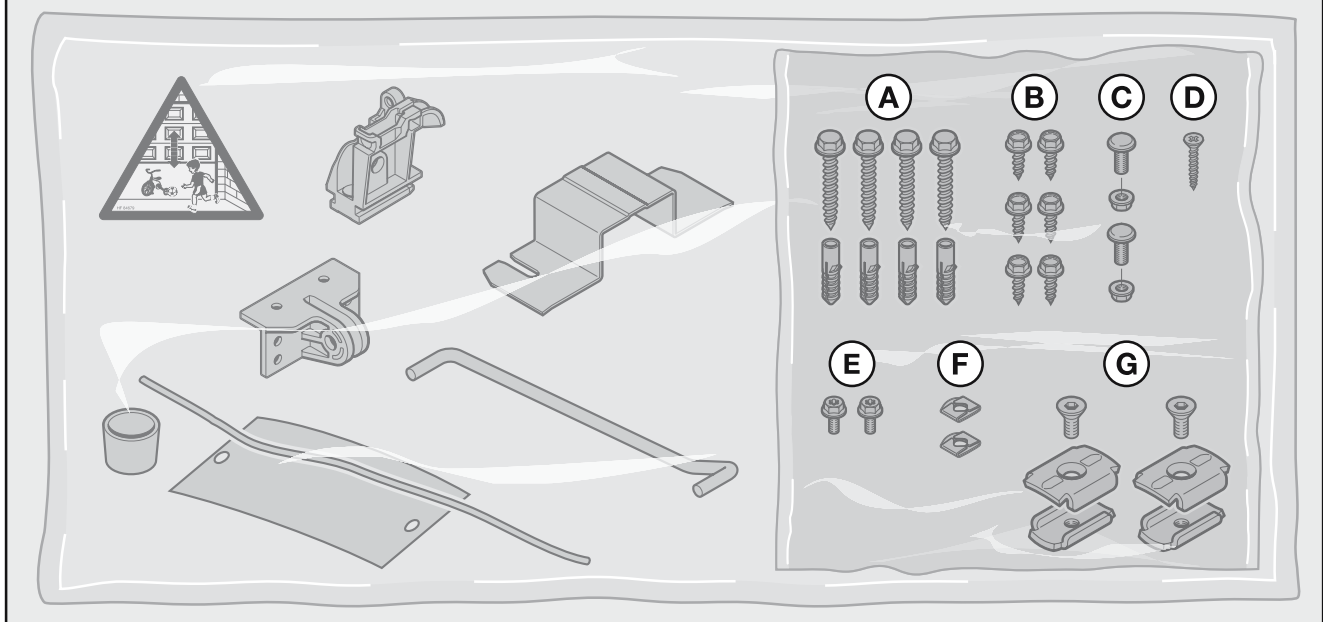
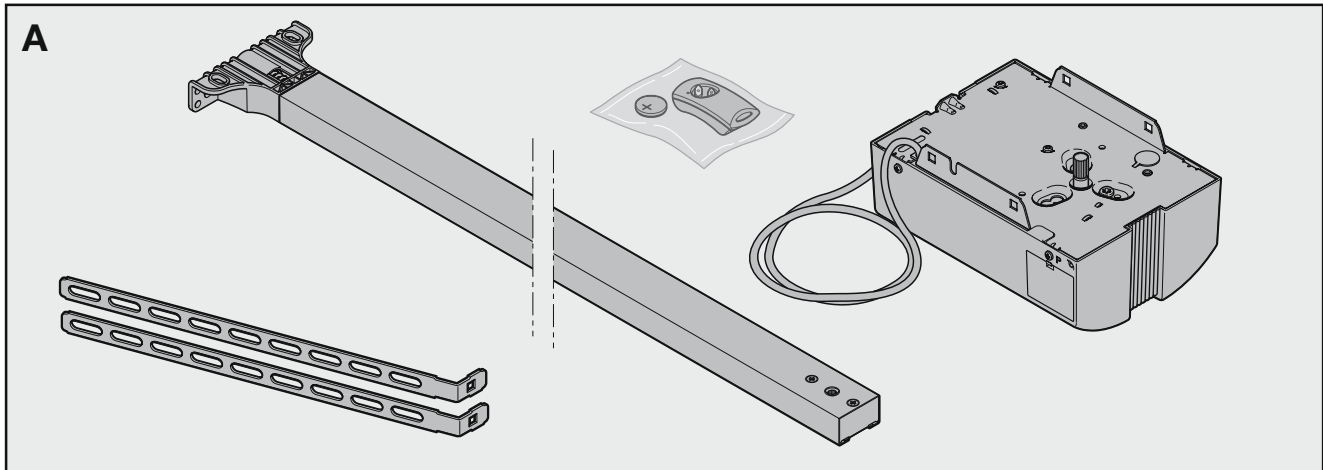

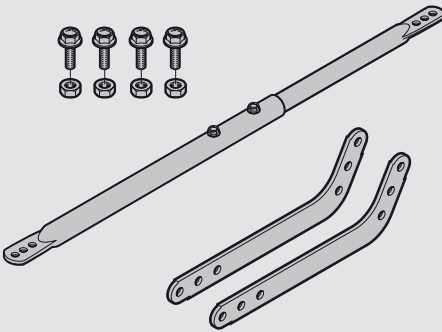
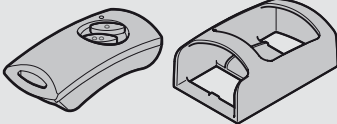
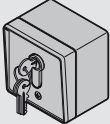
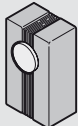
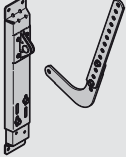
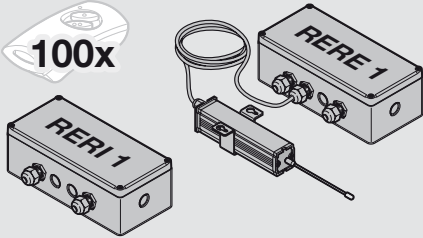
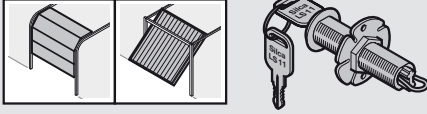
C ₁		<p>Extended fitting bracket</p> <p>If the clearance between the highest point of the door and the ceiling is less than 30 mm, the garage door operator can also be mounted behind the opened door if enough space is available. In the following cases, an extended fitting bracket must be used:</p> <ul style="list-style-type: none"> – for a lintel with offset of 1,000 mm – for up-and-over doors up to 2,625 mm high – for sectional doors (N tracks) up to 2,375 mm high – for sectional doors (L or Z tracks) up to 2,250 mm high – for up-and-over doors up to max. 2,750 mm high – for sectional doors (N/L and Z tracks) up to max. 3,000 mm high
C ₂		<p>RSE2 hand transmitter</p> <p>This 2-button hand transmitter works with a rolling code (frequency: 433.92 MHz) that changes with each sending procedure. The hand transmitter is equipped with two buttons, i.e. you can use the second button to open another door or turn on the outdoor lights if there is an optional receiver for it.</p>
C ₃		<p>Surface-mounted/recessed key switch</p> <p>You can use this to open and close the door from the exterior with a key. Two versions in one device – surface-mounted or recessed.</p>
C ₄		<p>IT1 internal push button</p> <p>The internal push button is quite practical if you wish to open or close the door conveniently from within the garage; includes 7 m connecting lead (2-wire) and fixing material.</p>
C ₅		<p>Fitting bracket for sectional doors (from other manufacturers)</p>
C ₆		<p>RERI 1/RERE 1 receiver</p> <p>This 1-channel receiver enables operation of a garage door operator with one hundred additional hand transmitters (buttons).</p> <p>Memory spaces: 100 Frequency: 433.92 MHz (rolling code) Operating voltage: 24 V DC/AC or 230/240 V AC Relay output: On/off</p>
C ₇		<p>NET3 emergency release lock</p> <p>Necessary for garages without a second entrance.</p> <ul style="list-style-type: none"> – Bore Ø13 mm – Cable length 1.5 m

ENGLISH

Table of contents

Page

A	Items supplied	2	5	Integral radio receiver	12
B	Tools needed for assembly	2	5.1	Programming the desired hand transmitter button..	12
C	Accessories for the garage door operator	3	5.2	Deleting all memory spaces in the integral radio receiver	12
D	Spare parts	43			
E	Drill stencil	45			
1	Important information	5	6	Changing the bulb	12
1.1	Important safety instructions.....	5	7	Disassembly	13
1.1.1	Warranty	5	8	Warranty conditions	13
1.1.2	Inspection of the door/door system.....	5	9	Technical data	13
1.2	Important instructions for safe fitting	5	10	Miscellaneous	14
1.2.1	Before fitting	5	10.1	RSE2 hand transmitter	14
1.2.2	When performing the fitting work	6	10.1.1	Commissioning/changing batteries	14
1.3	Safety instructions	6			
1.4	Maintenance instructions.....	6			
1.5	Notices on illustrated section.....	6			
1.6	Warnings used.....	7			
2	Definitions	7			
3	Fitting instructions	8			
3.1	Clearance needed for operator fitting	8			
3.2	Door locking on the sectional door	8			
3.3	Centre locking on a sectional door	8			
3.4	Off-centre reinforcement profile on a sectional door.....	8			
3.5	Door locking on an up-and-over door	8			
3.6	Up-and-over doors with an ornamental iron handle ..	8			
3.7	Up-and-over doors with timber infill	8			
3.8	Boom fitting	8			
3.9	Fitting the operator	8			
4	Initial start-up/connection of additional components/operation	8			
4.1	Determination of door end-of-travel positions by fitting the end stops	8			
4.2	Instructions for electrical work	9			
4.3	Initial operator start-up.....	9			
4.3.1	Display and control elements.....	9			
4.3.2	Deleting the door data	9			
4.3.3	Teaching in the operator	9			
4.4	Connection of additional components/ accessories	10			
4.4.1	Connection of external "impulse" buttons to start or stop door runs*	10			
4.4.2	Connection of a 2-wire photocell*	10			
4.5	DIL switch function settings	10			
4.5.1	DIL switch A: activate 2-wire photocell.....	10			
4.5.2	DIL switch B: without function	10			
4.6	Instructions for operating the garage door operator	10			
4.6.1	Normal operation.....	10			
4.6.2	Operator belt tension.....	11			
4.6.3	Operation after actuation of the mechanical release.....	11			
4.6.4	Operator light messages	11			
4.6.5	Error messages	11			



Illustrated section28-42

Dissemination as well as duplication of this document and the use and communication of its content are prohibited unless explicitly permitted. Noncompliance will result in damage compensation obligations. All rights reserved in the event of patent, utility model or design model registration.

Dear customer,

We are delighted that you have decided to choose a quality product from our company. Be sure to keep this manual in a safe place!

Please read and follow these instructions. They contain important information on the fitting, operation and proper care and maintenance of the garage door operator so that you can enjoy this product for many years.

Please follow all of our safety instructions and warnings, which are specially marked with **DANGER**, **WARNING**, **ATTENTION**, or **Note**.

1 Important information

ATTENTION

Incorrect fitting and/or handling of the operator could result in serious injury. Be sure to follow all instructions contained in this manual!

1.1 Important safety instructions

The garage door operator is intended **exclusively** for the pulsed operation of spring-stabilised sectional and up-and-over garage doors in the **private/non-commercial sector**. **It must not be used for doors without a safety catch. Use in the commercial sector is prohibited!**

Please note the manufacturer's specifications regarding the door and operator combination. Potential hazards as outlined in EN 12604 und EN 12453 are avoided by construction and assembly according to our guidelines. **Door systems that are located in a public area and only have one protective device, such as a power limit, may only be operated under supervision.**

1.1.1 Warranty

The warranty and product liability are rendered void if you perform design modifications without the consent of the manufacturer or conduct or initiate improper installations contrary to assembly guidelines. Furthermore, the manufacturer assumes no responsibility for the accidental or careless operation of the operator and accessories, as well as for improper maintenance of the door and its counterweight. Expendable or wearable material such as batteries and light bulbs are also exempt from warranty claims.

NOTE:

In the event of garage door operator failure, a specialist must be commissioned immediately for the inspection/repair work.

1.1.2 Inspection of the door/door system

The construction of the operator is not designed for operation with stiff doors, that is, doors that can no longer be opened or closed manually, or can only be opened/closed manually with difficulty.

For this reason, it is necessary to inspect the door before fitting the operator to make sure that it is also easy to operate manually.

To do this, the door should be lifted by about one metre and then released. The door should stay in this position and **neither** move downward **nor** upward. If the door does move in either direction, there is a danger that the compensating springs/weights are not properly adjusted or are defective. In such cases, increased wear and door system malfunctions should be anticipated.

DANGER!

Never try to replace, adjust, repair or reposition the compensating springs for the counterbalance of the door or the spring mountings yourself. They are under high tension and can cause serious injury.

Furthermore, the entire door system (joints, door bearings, cables, springs and fastening parts) should be inspected for wear and potential damage. Check for the presence of rust, corrosion or tears. The door system should not be used if repair or adjustment work must be conducted, since a malfunction in the door system or an incorrectly aligned door can also cause serious injury.

WARNING

For your own safety, have a specialist conduct work on the door compensating springs and, if necessary, maintenance and repair work, before you install the operator! Only correct fitting and maintenance performed by a competent/qualified company or a competent/qualified person in accordance with the instructions can ensure safe and intended function of an installation. According to EN 12635, a qualified person is a person with suitable training, specialist knowledge and practical experience sufficient to correctly and safely fit, test, and maintain a door system.

1.2 Important instructions for safe fitting

The specialist must ensure that the applicable regulations on occupational safety, as well as the regulations on the operation of electrical devices, are followed during assembly work. The national guidelines must be observed.

1.2.1 Before fitting

Before fitting the garage door operator, check whether the door is free of mechanical defects and balanced, so that it is easy to operate manually (EN 12604). Furthermore, check whether the door can be opened and closed properly (see Chapter 1.1.2).

ENGLISH

In addition, the mechanical locking devices of the door that are not needed with a garage door operator must be put out of commission. This especially includes the locking mechanisms of the door lock (see Chapters 3.2 and 3.5).

The garage door operator is designed for operation in dry rooms and therefore must not be fitted outdoors. The garage ceiling must guarantee secure fastening of the operator. For ceilings which are too high or too light, the operator must be fastened on additional struts.

1.2.2 When performing the fitting work

NOTE:

The provided fitting materials must be inspected by the fitter for their suitability at the intended fitting location.

⚠ WARNING

The provided fixing materials (plugs) are only intended for concrete \geq B15 (see Figures 1.8a/1.5b/3.2a/3.3).

The clearance between the highest point of the door and the ceiling (also when opening the door) must be at least 30 mm (see Figures 1.1a/1.1b). If the clearance is smaller, the operator can also be mounted behind the opened door if enough space is available. In such cases, an extended fitting bracket can be used, which must be ordered separately (see Accessories for garage door operator/C1). In addition, the garage door operator can be arranged up to max. 50 cm off-centre. The electrical outlet necessary for the electrical connection should be fitted approx. 50 cm from the operator head.

Please check these dimensions!

1.3 Safety instructions

⚠ WARNING



Fixed control devices (e.g. buttons, etc.) must be fitted within sight of the door, but away from moving parts and at a height of at least 1.5 m. They must be out of the reach of children at all costs!

NOTE:

The sign warning about getting trapped must be attached in a noticeable place or near the permanently installed operator buttons!

⚠ WARNING



Make sure that

- no people or objects are allowed in the area of door movement.
- children are not allowed to play near the door system!
- the cable of the mechanical release on the slide carriage cannot become caught on a ceiling support system or anything projecting from the vehicle or door.

NOTE:

An emergency release lock (see Accessories for garage door operator C7) is required for garages without a second entrance in order to prevent users from locking themselves out. This lock must be ordered separately and be checked monthly for proper function.

⚠ CAUTION

Do not hang on the release knob with your body weight!

1.4 Maintenance instructions

The garage door operator is maintenance-free. In the interest of your own safety, it is recommended that you have the door system inspected **by a specialist in accordance with the manufacturer's specifications**. According to EN 12635, a qualified person is a person with suitable training, specialist knowledge and practical experience sufficient to correctly and safely fit, test, and maintain a door system.

NOTE:

All safety and protective functions must be checked monthly to ensure that they are in working order, and any malfunctions and/or defects must be rectified immediately if necessary.

Inspection and maintenance may only be conducted by a specialist; contact your supplier for this purpose. A visual inspection may be carried out by the operator.

Contact your supplier concerning necessary repairs. No guarantee is made for improper or non-professional repairs.

1.5 Notices on illustrated section

The fitting of the operator with a sectional door is depicted in the illustrated section. Deviations for fitting with an up-and-over door are also shown. The figure number is assigned the letter

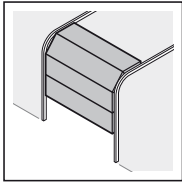

(a) for the **sectional door** and

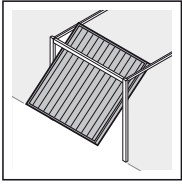

(b) for the **up-and-over door**.

Several figures also contain the symbol below with a text reference. These text references provide you with important information on the fitting and operation of the garage door operator in the following text section.

Example:



2.2 = see text section, Chapter 2.2

The following symbol is also depicted in the illustrated section, as well as in the text section, at the places where the DIL switches for setting the control are explained.



= This symbol indicates the **factory setting(s)** of the DIL switches.

All dimensions in the illustrated section are in [mm].

1.6 Warnings used

ATTENTION
Indicates a danger that can lead to damage or destruction of the product .

	<p>The general warning symbol indicates a danger that can lead to injury or death. In the text section, the general warning symbol will be used in connection with the caution levels described below. In the illustrated section, an additional instruction refers to the explanation in the text section or a special notice.</p>
--	---

! CAUTION

Indicates a danger that can lead to minor or moderate injuries.

! WARNING

Indicates a danger that can lead to death or serious injuries.

! DANGER

Indicates a danger that can immediately lead to death or serious injuries.

2 Definitions

DIL switches

Switches located under the side flap of the operator cover for activating the operator functions.

Impulse control

With each push of the button, the door is started against the previous direction of travel, or the motion of the door is stopped.

Force learning cycle

The forces necessary for door travel are learned in this force learning cycle.

Photocell

The photocell is a safety device. If the photocell is activated while the door is moving towards the "CLOSE" end-of-travel position, the door will stop and move in the opposite direction.

Normal operation

Door movement with the learned travel distances and forces.

Reference cycle

Door cycle towards the OPEN end-of-travel position in order to set the basic position.

Reverse cycle/safety cycle

Door travel in the opposite direction when the safety device or power limit is activated.

Distance learning cycle

Door cycle with which the operator learns the path of travel.

Path of travel

The distance the door takes to traverse from the OPEN end-of-travel position to the CLOSE end-of-travel position.

ENGLISH

3 Fitting instructions

NOTE:

Cover the operator during drilling work, as drilling dust and chippings can lead to malfunctions.

3.1 Clearance needed for operator fitting

The clearance between the highest point of the door travel and the ceiling must be at least 30 mm (see Figures 1.1a/1.1b). **Please check this dimension!**

3.2 Door locking on the sectional door

The mechanical door locking on the sectional door must be completely disassembled (see Figure 1.5a).

 **WARNING**

The rope must be removed while the operator is being fitted (see Figure 1.2a)

3.3 Centre locking on a sectional door

For sectional doors with centre door locking, the lintel ceiling console and link bracket must be arranged max. 50 cm off-centre. Before drilling, the position of the lintel ceiling console on the lintel or ceiling must be determined (see Figure 1.8a). For this purpose, use the supplied drill stencil in the appendix of this manual.

3.4 Off-centre reinforcement profile on a sectional door

For an off-centre reinforcement profile on a sectional door, the link bracket must be fitted on the nearest reinforcement profile to the left or right (see Figure 1.7a).

3.5 Door locking on an up-and-over door

The mechanical door locking on an up-and-over door must be rendered inoperable (see Figures 1.2b/1.3b). For **door models not covered here**, the catches must be blocked on site.

3.6 Up-and-over doors with an ornamental iron handle

NOTE:

In a deviation from the illustrated section (see Figure 1.5b), the lintel ceiling console and link bracket must be attached max. 50 cm off-centre for **up-and-over doors with ornamental iron door handles**.

3.7 Up-and-over doors with timber infill

For N80 doors with timber infill, the bottom holes on the lintel ceiling console must be used for fitting (see Figure 5.3b).

3.8 Boom fitting

(see Figure 2)

1. Place the supplied carriage top on the carriage coupling and screw it securely in place.
2. If necessary, pull out the coupling slider (e.g. with a screwdriver).
3. Assemble the cord knob completely and attach it to the slide carriage.
4. Fasten the boom using the clamp clip and the 2 screws on the operator head.

3.9 Fitting the operator

 **WARNING**

The provided fixing materials (plugs) are only intended for concrete \geq B15.

The completely assembled operator is fitted on the lintel or under the ceiling. First, only tighten slightly on the side of the lintel ceiling console (see Figures 5.3a/5.3b). Then determine the drilling positions of the suspensions fastened to the operator head and fit them securely under the ceiling (see Figure 5.4). Next, securely tighten the lintel ceiling console (see Figure 5.5).

4 Initial start-up/connection of additional components/operation

4.1 Determination of door end-of-travel positions by fitting the end stops

1. The end stop for the OPEN end-of-travel position must be fitted loosely in the boom between the slide carriage and operator. Once the fitting bracket has been mounted (see Figures 4a/4b), the door must be manually pushed into the OPEN end-of-travel position → this will push the end stop into the correct position (see Figure 6.1).
2. The end stop for the OPEN end-of-travel position must be tightened (see Figure 6.1).
3. The end stop for the CLOSE end-of-travel position must be fitted loosely in the boom between the slide carriage and lintel ceiling console, and the door must be manually pushed into the CLOSE end-of-travel position → this will push the end stop into the correct position (see Figure 6.2).
4. The end stop for the CLOSE end-of-travel position must be tightened (see Figure 6.2).

NOTE:

If the door cannot easily be pushed manually into the desired OPEN or CLOSE end-of-travel position, this means that the door mechanism is too stiff for operation with the garage door operator and must be inspected (see Chapter 1.1.2)!

4.2 Instructions for electrical work

CAUTION

The following points must be kept in mind during all electrical work:

- Electrical connections may only be performed by a qualified electrician!
- The on-site electrical installation must conform to the applicable protective regulations (230/240 V AC, 50/60 Hz)!
- The mains plug must be disconnected before any work is performed on the operator!
- External voltage on the connecting terminals of the control will destroy the electronics!
- In order to avoid malfunctions, make sure that the operator's connection cables (24 V DC) are laid out in a separate installation system from other supply lines (230/240 V AC)!

4.3 Initial operator start-up

The operator has a power failure-proof memory in which the door-specific data (travel, forces needed during door travel, etc.) is stored during the learning process and updated during subsequent door travels. This data is only valid for this door and must thus be deleted and relearned for use with another door or if the door's travel behaviour has changed significantly (i.e. in the event of subsequent displacement of the end stops or fitting of new springs, etc.).

4.3.1 Display and control elements

- T button:**
- Operator learning (travel and forces needed)
 - Impulse button in normal operation
- P button:**
- Hand transmitter learning
 - Deleting the registered hand transmitters
- Red LED:**
- Display of operating conditions
 - Display of error messages
- Operator light:**
- Display of operating conditions
 - Garage illumination
- DIL switches:**
- Activation of operator functions

4.3.2 Deleting the door data

(See Figure 7)

In the delivery condition, the door data has been deleted and the operator can be immediately taught in → see Chapter 4.3.3 – Teaching in the operator.

If it is necessary to teach in again, the door data can be deleted as follows:

1. Disconnect the mains plug.
2. Push and hold down the **T** button on the operator cover.
3. Connect the mains plug and push the above-mentioned button until the operator light flashes once.
4. It can now be taught in again. This is signalled by the red LED flashing 8 times (OPEN reference run necessary).

NOTE:

You can read more about operator light messages (repeated flashing when the mains plug is plugged in) in Chapter 4.6.4.

4.3.3 Teaching in the operator

Among other things, the travel and forces needed during the opening and closing runs are learned and saved in a power failure-proof manner during the teach-in process.

NOTE:

Before the operator can be taught in again, the existing door data must be deleted (see Chapter 4.3.2) and the slide carriage must be engaged.

1. If necessary, the disengaged slide carriage must be prepared for engagement by pushing the green coupling slider on the carriage guide (see Figure 8). To do this, move the door manually until the slide carriage snaps into the carriage coupling.
2. If necessary, connect the mains plug; the operator light will then flash twice (see Figure 8/Chapter 4.6.4).
3. Actuate the **T** button on the operator cover (see Figure 9) → the door will open with a flashing operator light (OPEN reference run) until the end stop for the OPEN end-of-travel position has been reached.
4. The door will automatically close and then open again with a flashing operator light. The travel is learned during the process. If a warning lamp is present and attached, it will also flash during the door runs.

NOTE:

If connected, the photocell is not active during the teach-in process.

5. Once more, the door will automatically close and then open again with a flashing operator light. The forces needed for the opening and closing runs are learned during the process. The door will stop in the OPEN end-of-travel position. The operator light will then light up continually and go out after approx. 2 minutes. The operator has been taught in and is ready for operation.

NOTE:

While conducting the teach-in process, check to make sure that the door reaches its completely closed position. If it does not, reposition the CLOSE end stop accordingly and teach in the operator again. Also check whether the door opens completely (the slide carriage stops shortly before the OPEN end stop).

ENGLISH

4.4 Connection of additional components/ accessories

ATTENTION

The following points must be kept in mind during all electrical work:

- Electrical connections may only be performed by a qualified electrician!
- The on-site electrical installation must conform to the applicable protective regulations (230/240 V AC, 50/60 Hz)!
- The mains plug must be disconnected before any work is performed on the operator!
- External voltage on the connecting terminals of the control will destroy the electronics!
- In order to avoid malfunctions, make sure that the operator's connection cables (24 V DC) are laid out in a separate installation system from other supply lines (230/240 V AC)!

In order to connect additional components, the side flap on the operator cover must be taken off (see Figure 10). The terminals that the additional components are connected to, such as volt-free internal push buttons or photocells, only carry a non-hazardous low-voltage current of approx. 24 V DC.

All connecting terminals can be given multiple assignments, but with a maximum of 1x1.5 mm² (see Figure 11). The mains plug must be disconnected before connecting!

4.4.1 Connection of external "impulse" buttons to start or stop door runs*

One or more buttons with normally open contacts (volt-free), such as internal push buttons or key switches, can be connected in parallel (see Figure 12).

4.4.2 Connection of a 2-wire photocell*

2-wire photocells must be connected as shown in Figure 13.

NOTE:

Follow the fitting instructions when mounting photocells.

* Accessory, not included as standard equipment!

4.5 DIL switch function settings

Several of the operator's functions must be programmed using the DIL switches. Before initial start-up, the DIL switches are in factory settings, i.e. the switches are in the OFF position (see Figure 10).

Changes to the DIL switch settings are only permissible if

- the operator is at rest,
- no radio control is being programmed.

The DIL switches must be set as follows in accordance with national regulations, the desired safety devices and the on-site circumstances.

4.5.1 DIL switch A: activate 2-wire photocell

(See Figure 13)

If the light path is interrupted during closure, the operator will stop immediately and, after a short pause, reverse until it reaches the OPEN end-of-travel position.

ON	2-wire photocell
OFF 	No safety device (delivery condition)

4.5.2 DIL switch B: without function

4.6 Instructions for operating the garage door operator

NOTE:

As a general rule, the initial function tests and programming or extension of the remote control should be conducted inside the garage.

Only operate the garage door operator if you can see the door's area of travel! Wait until the door comes to a rest before you move into the door's area of travel! Make sure that the door has opened completely before driving in or out of the garage!

The mechanical release function must be inspected **monthly**. The cord knob may only be actuated when the door is closed; otherwise there is a danger that the door will close rapidly if the springs are weak, broken or defective, or if the counterbalance is inadequate.

CAUTION

Do not hang on the cord knob with your body weight!

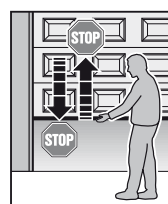

Instruct all persons who use the door system on the proper and safe use of the garage door operator. Demonstrate and test the mechanical release, as well as the safety reversal.

To do this, stop the door with both hands during its closing run; the door system should switch off and trigger the safety reversal. The door system must also switch off and stop the door while it is opening.

4.6.1 Normal operation

In normal operation, the garage door operator works exclusively according to the impulse sequence control. It does not matter whether an external button, a programmed hand transmitter button or the **T** button on the operator cover has been actuated:

- 1st impulse: The door runs towards an end-of-travel position.
 2nd impulse: The door stops.
 3rd impulse: The door runs in the opposite direction.
 4th impulse: The door stops.
 5th impulse: The door runs in the direction of the end-of-travel position selected in the 1st impulse,
 etc.

The operator light will light up during a door run and automatically go out approx. 2 minutes after the door run ends.

4.6.2 Operator belt tension

During the start-up and slow-down phase, it is possible that the belt will briefly hang out of the boom profile. However, this does not result in any technical consequences and does not negatively affect the function and service life of the operator.

The tension of the toothed belt should be checked every six months. If necessary, adjust the tension of the toothed belt according to Figure 2.3).

CAUTION

Do not reach into the boom with your fingers during door travel → Danger of crushing!

4.6.3 Operation after actuation of the mechanical release.

If, for example, the mechanical release is actuated due to a mains power failure, the slide carriage must be snapped back into the carriage coupling to resume normal operation:

1. Move the operator until the carriage coupling can be easily reached in the operator boom for the slide carriage.
2. Push down the green coupling slider on the slide carriage (see Figure 8).
3. Move the door manually until the slide carriage snaps back into the carriage coupling.
4. Check whether the door completely reaches its closed position and opens completely by conducting multiple uninterrupted door runs (the slide carriage stops shortly before the OPEN end stop).

Now, the operator is ready for normal operation again.

NOTE:

If the behaviour does not correspond to that described in step 4, even after multiple door runs, a new learning cycle is necessary (see Chapter 4.3.3).

4.6.4 Operator light messages

If the mains plug is plugged in without the T button having been pushed, the operator light will flash two, three or four times.

Two flashes

Show that no door data is present or that the door data has been deleted (delivery condition); it can then be taught-in immediately.

Three flashes

Signalise that saved door data is present, but the last door position is not sufficiently known. For this reason, the next run will be an OPEN reference run. Thereafter, "normal" door runs will follow.

Four flashes

Indicate that saved door data is present and that the last door position is sufficiently known, i.e. "normal" door runs that take the impulse sequence control (open-stop-close-stop-open, etc.) into account can proceed immediately (normal behaviour after a successful teach-in and power failure). For safety reasons, the door will always open upon the first impulse command after a power failure **during** a door run.

4.6.5 Error messages

(Red LED on the operator cover)

Causes of unexpected operation can be easily identified by means of the red LED. In a taught-in condition (normal operation), the LED lights up continually and goes out as long as an externally connected impulse is present.

NOTE:

If normal operation of the garage door operator with the radio receiver or the T button is otherwise possible, a short circuit in the external button's connecting lead or in the button itself can be recognised through the behaviour specified in Chapter 4.6.5.

LED:	Flashes 2x
Cause:	A photocell connected to the terminals with the photocell symbol was interrupted or actuated. A safety reversal may have occurred.
Remedy:	Eliminate the obstruction cause and/or check the photocell and replace if necessary.
Acknowledgement:	Renewed impulse entry by means of an external button, the radio receiver or the T button – if in the OPEN end-of-travel position, a closing run will take place, otherwise an opening run.
LED:	Flashes 3x
Cause:	The CLOSE power limit has been activated – a safety reversal took place.
Remedy:	Eliminate the obstruction. If the safety reversal took place for no apparent reason, check the door mechanics or the tension of the operator belt. If necessary, delete the door data (see Chapter 4.3.2) and teach it in again (see Chapter 4.3.3), or adjust the tension of the operator belt (see Chapter 3.8).

ENGLISH

Acknowledgement:	Renewed impulse entry by means of an external button, the radio receiver or the T button – an opening run will take place.
LED:	Flashes 5x
Cause:	The OPEN power limit has been activated – the door was stopped during an opening run.
Remedy:	Eliminate the obstruction. If stopping before the OPEN end-of-travel position was caused for no apparent reason, check the door mechanics or the tension of the operator belt. If necessary, delete the door data (see Chapter 4.3.2) and teach it in again (see Chapter 4.3.3), or adjust the tension of the operator belt (see Chapter 3.8).
Acknowledgement:	Renewed impulse entry by means of an external button, the radio receiver or the T button – a closing run will take place.
LED:	Flashes 6x
Cause:	Operator error/malfunction in operator system
Remedy:	If necessary, delete the door data (see Chapter 4.3.2) and teach it in again (see Chapter 4.3.3). If the operator error occurs again, the operator should be replaced.
Acknowledgement:	Renewed impulse entry by means of an external button, the radio receiver or the T button – an opening run will take place (OPEN reference run).
LED:	Flashes 7x
Cause:	The operator has not been taught in yet (this is only a notice and not a malfunction).
Remedy/ acknowledgement:	The CLOSE learning cycle must be triggered by an external button, the radio receiver or the T button.
LED:	Flashes 8x
Cause:	The operator requires an OPEN reference run (this is only a notice and not a malfunction).
Remedy/ acknowledgement:	The OPEN reference run must be triggered by an external button, the radio receiver or the T button.
Note:	This is the normal status after a power failure if no door data is present or has been deleted and/or the last door position is not sufficiently known.

5 Integral radio receiver

The garage door operator is equipped with an integral radio receiver. With the integral radio receiver, the "impulse" function (open - stop - close - stop) can be programmed on a maximum of 6 different hand transmitter buttons. If more than 6 hand transmitters are programmed, the first one programmed will be deleted without advance warning. All six memory spaces are empty or deleted in the delivery condition. Programming and deleting are only possible when the operator is at rest.

5.1 Programming the desired hand transmitter button

(See Figure 14)

Insert the battery in the hand transmitter (see Chapter 10.1.1). Push the **P** button on the operator cover briefly. The red LED will begin to flash, signalling that the desired hand transmitter button can be programmed. To do so, the hand transmitter button must be held down until the LED begins flashing rapidly. The hand transmitter button must then be released and pushed again within 15 seconds, until the LED begins flashing very rapidly. Now, release the hand transmitter button.

Once the rapid flashing stops, the desired hand transmitter button has been successfully programmed and the red LED will remain lit. Now, conduct the function test.

5.2 Deleting all memory spaces in the integral radio receiver

(See Figure 15)

Individual memory spaces cannot be deleted in a targeted fashion with the integral radio receiver, i.e. only complete deletion is possible (delivery condition).

Push the **T** button on the operator cover and hold it down. The red LED will flash slowly for approx. 4 seconds, signalling readiness for deletion. The flashing rhythm becomes more rapid. Now, release the **P** button.

NOTE:

The deletion process will be aborted if the **P** button is released before 4 seconds have elapsed.

Once the rapid flashing stops, all memory spaces have been deleted and the red LED will remain lit.

6 Changing the bulb

When changing the bulb, it must be cold and the door closed.

- Disconnect the mains plug.
- Change the 24 V/10 W B(a) bulb after 15 s (see Figure 16).
- Connect the mains plug.
- The operator light will flash four times.

7 Disassembly

NOTE:

When disassembling, observe the applicable regulations regarding occupational safety.

Proceed as follows to disassemble the operator with the boom (see Figure 17.2):

1. Close the door.
2. Disconnect the mains plug.
3. Remove the fitting bracket's securing pin on the side of the slide carriage.
4. Remove the fastening for the lintel ceiling console.
5. Remove the suspension fastening on the operator head.

Proceed as follows to disassemble the operator head from the boom (see Figure 17.3):

1. Remove the screws from the clamp clip.
2. Remove the clamp clip.
3. Pull the boom off the operator shaft.

8 Warranty conditions

Term of warranty

In addition to the statutory warranty from the dealer in the purchase contract, the manufacturer provides a warranty for a term of 2 years from the purchase date, depending on the type of operator. The warranty is not extended if a claim is made on it. The term of the warranty is six months for replacement deliveries and rectification of defects, but must amount to at least the remainder of the initial warranty period.

Prerequisites

The warranty claim only applies in the country in which the device was purchased. The goods must have been acquired through our authorised distribution channels. The warranty claim only applies to damages incurred to the subject of the contract itself. The proof of purchase is valid as evidence of your warranty claim.

Performance

For the term of the warranty, we shall rectify all defects of the products that can be demonstrably attributed to material or manufacturing defects. We shall replace the defective goods with defect-free goods at no charge, rectify the defects or compensate for loss in value according to our choice.

Damages caused by the following are excluded:

- improper fitting and connection,
- improper initial start-up and operation,
- external factors such as fire, water, abnormal environmental conditions,
- mechanical damage caused by accidents, falls, impact,
- negligent or intentional destruction,
- ordinary wear and tear,
- repairs conducted by unqualified persons,

- use of components other than those from the manufacturer,
- removal or defacing of the product number.

Replaced parts become the property of the manufacturer.

9 Technical data

Mains voltage: 230/240 V, 50/60 Hz,
stand-by approx. 6 W

Mains voltage type: Y

Protection category: Only for dry rooms

Automatic safety cut-out: Is automatically taught in for both directions separately.

Travel limit safety cut-out/ power limit Self-learning, wear-free, as it is designed without mechanical switches, additionally integrated travel time limit of approx. 45 seconds. Readjusting automatic safety cut-out for every door run.

Pull and push force: Max. 500 N

Motor: Direct current motor with hall sensor

Transformer: With thermal protection

Connection technology: Simple screw terminals, max. 1.5 mm², for internal and external buttons with impulse operation.

Special functions:

- Operator light, 2 minute light ex factory,
- 2-wire photocell can be attached.

Quick release: Actuated from inside with pull cord in the event of a power failure

Remote control: With RSE2 2-button hand transmitter (433.92 MHz) and integral radio receiver with 6 memory spaces.

Universal fittings: For up-and-over doors and sectional doors

Door travel speed: Approx. 10.5 cm per second (dependent on door size and weight)

Airborne sound emission of the garage door operator: The equivalent continuous sound pressure level of 70 dB (A-weighted) is not exceeded at a distance of three metres.

ENGLISH

Boom: Extremely flat at 30 mm. Three-part, with maintenance-free, patented toothed belt.

Use: Exclusively for private garages. For easy to move up-and-over and sectional doors with a door area of up to 7.125 m². Not intended for industrial/commercial use.

10.1.1 Commissioning/changing batteries

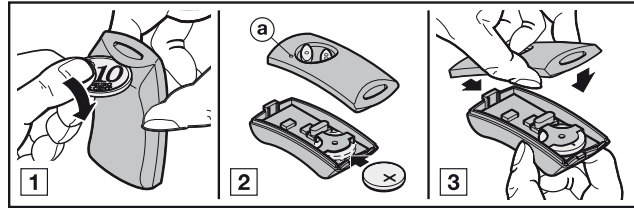

- Open the hand transmitter as shown.
- Insert the battery (CR2025, 3 volt lithium) with the correct polarity.
- Close the hand transmitter.

10 Miscellaneous

10.1 RSE2 hand transmitter

The hand transmitter works with a rolling code that changes with each sending procedure. For this reason, the hand transmitter must be programmed with the desired hand transmitter button on each receiver that is to be controlled (see Chapter 5.1/Receiver manual).

ATTENTION

The hand transmitters must be protected from moisture, dust and direct exposure to the sun. These conditions can impair function!

The LED (**a**) signals each push of the button on the hand transmitter (see Chapter 10.1.1). When the LED lights up during the process, it means that the hand transmitter is sending a code.

If the LED flashes when a button is pushed, it means that it is still sending, but the battery charge is so low that it must be replaced soon.

If the LED shows no reaction, check whether the battery is inserted correctly (see Chapter 10.1.1); the battery may have to be replaced with a new one.

WARNING



Hand transmitters should be kept away from children and may only be used by people who have been instructed on how the remote-control door functions! Generally, operation of the hand transmitter must be carried out within sight of the door! Remote-control door systems can only be driven or passed through if the garage door is in the OPEN end-of-travel position!

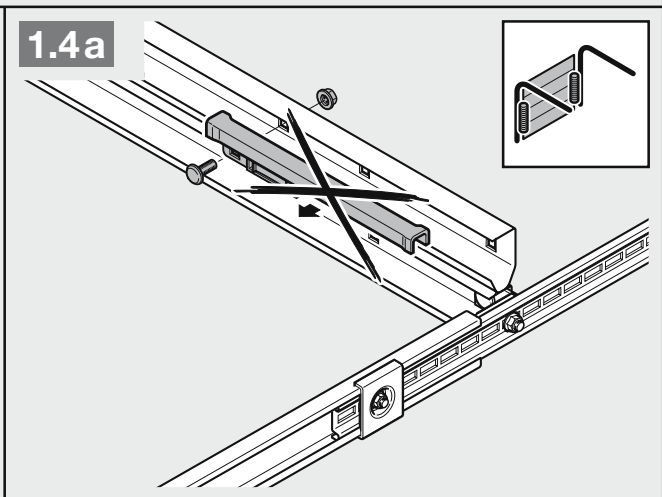
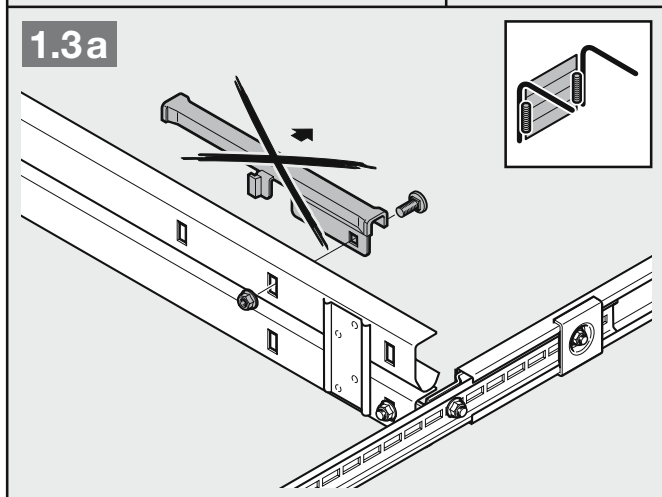
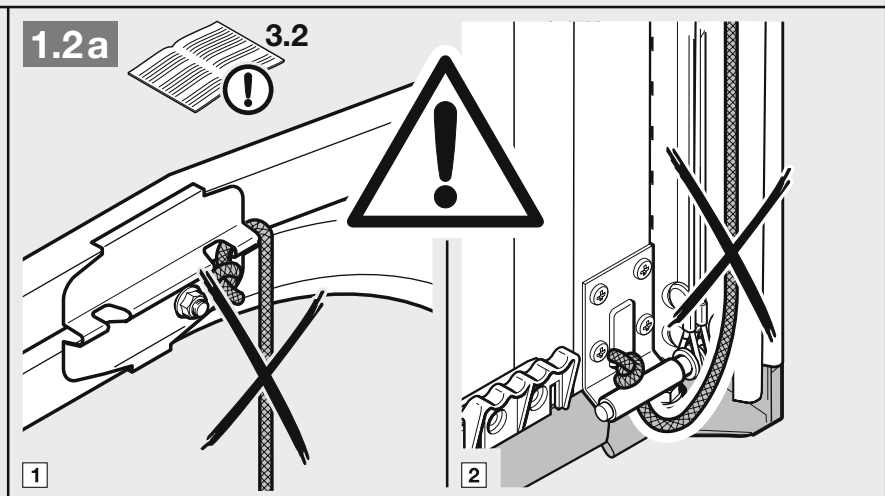
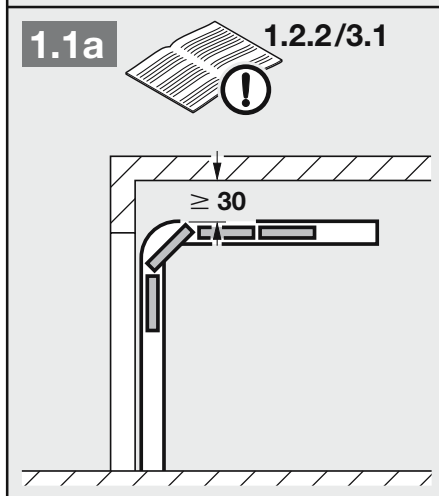
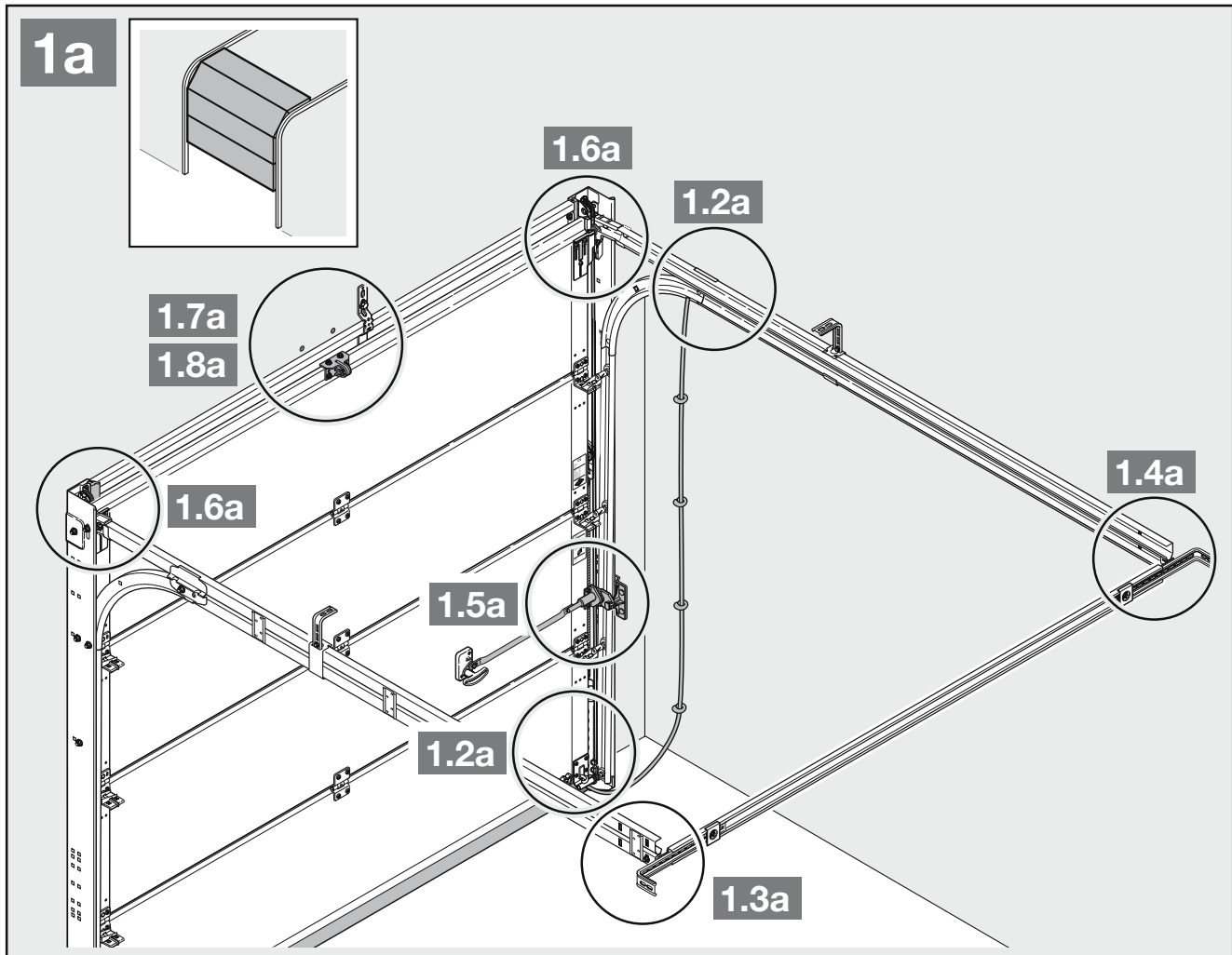

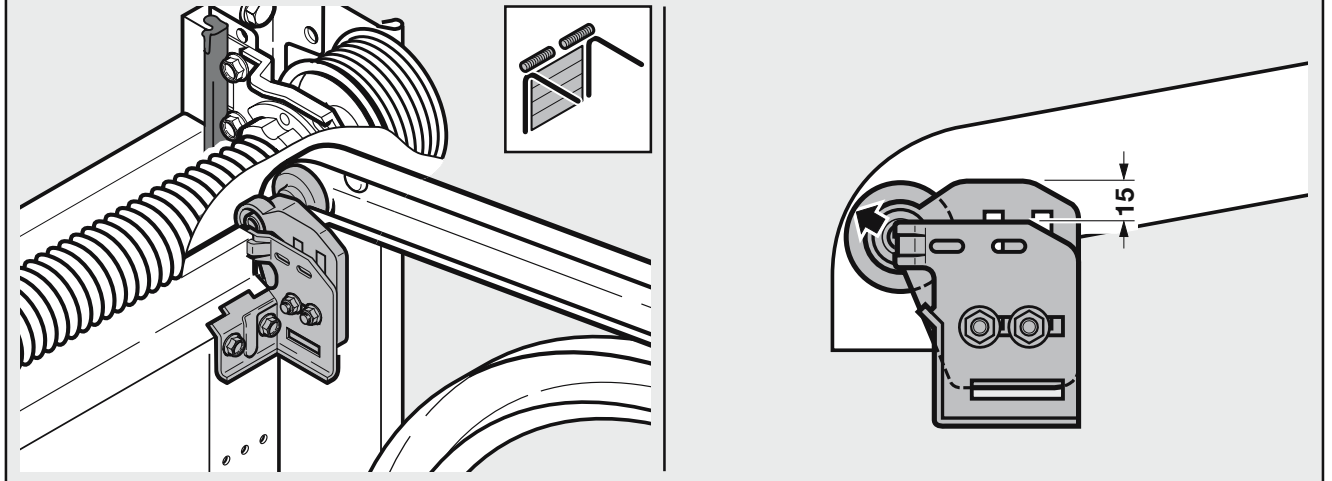
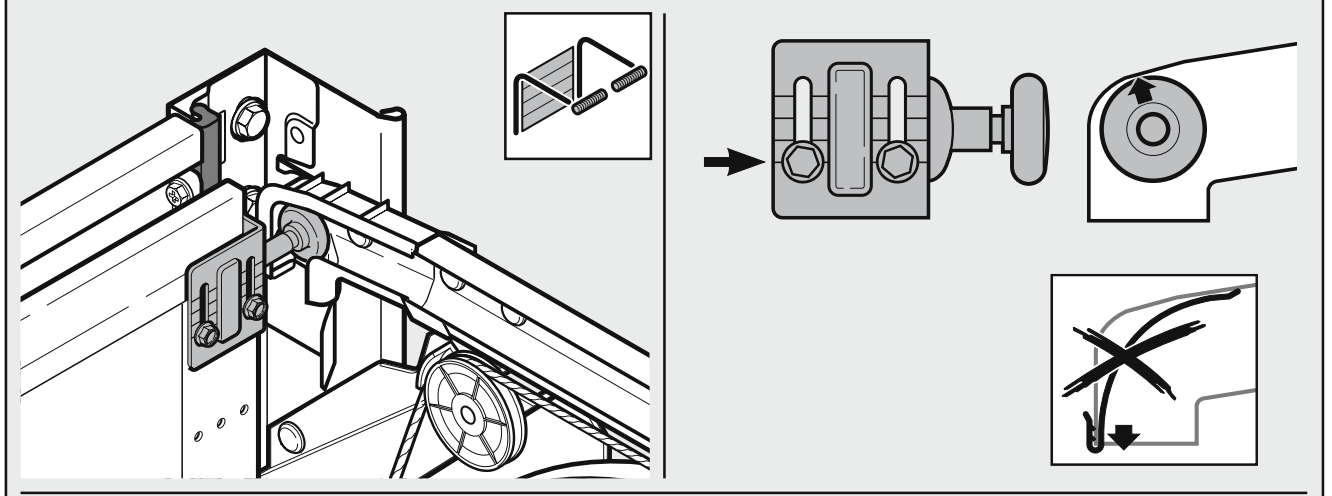
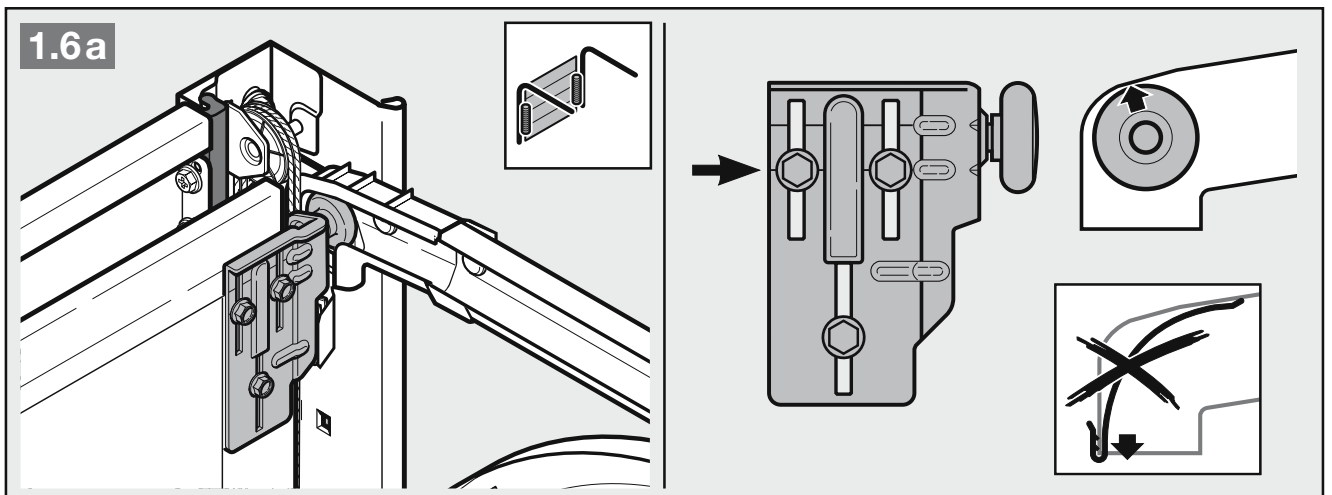
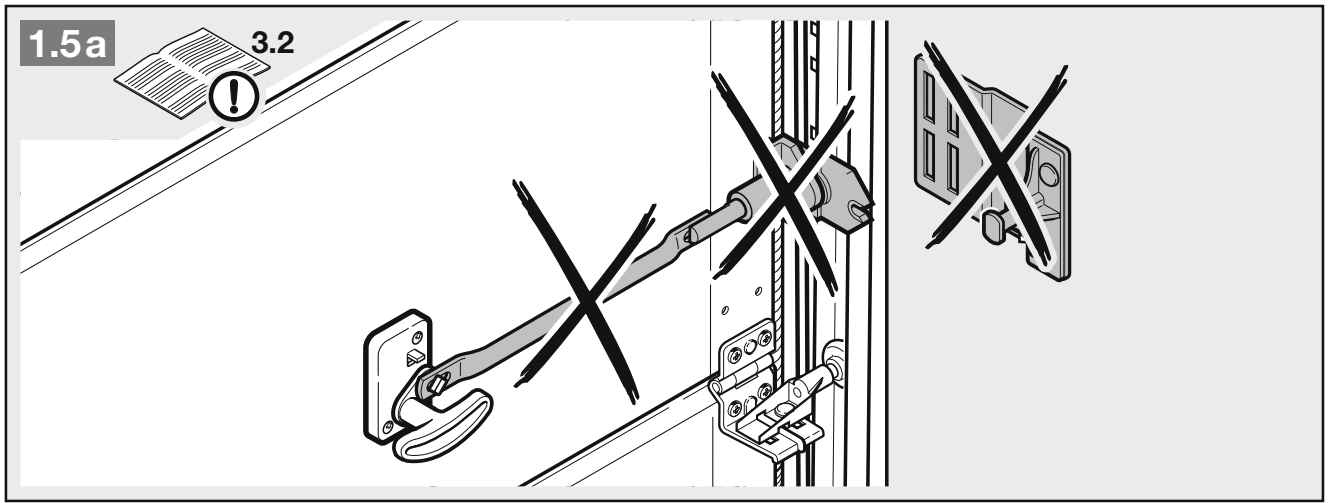

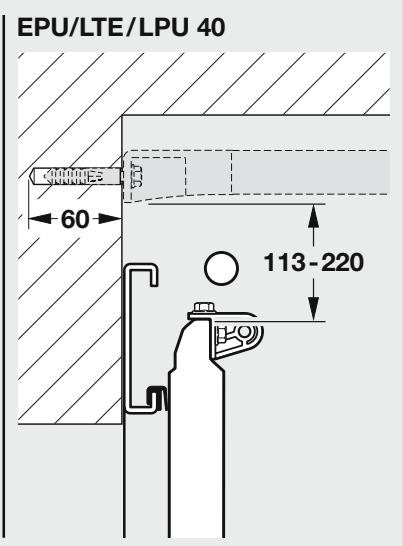
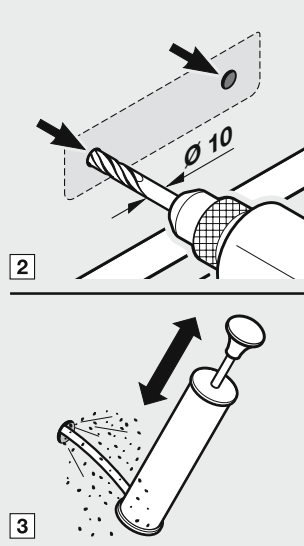
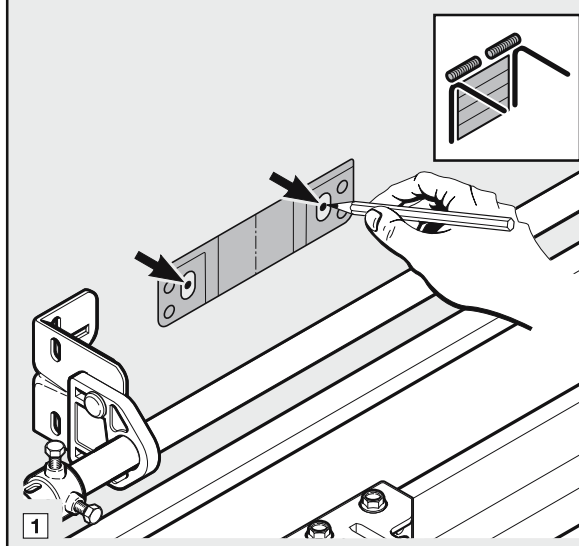
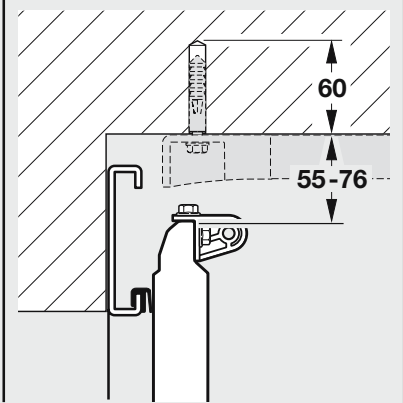
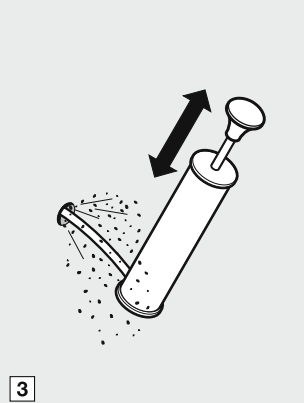
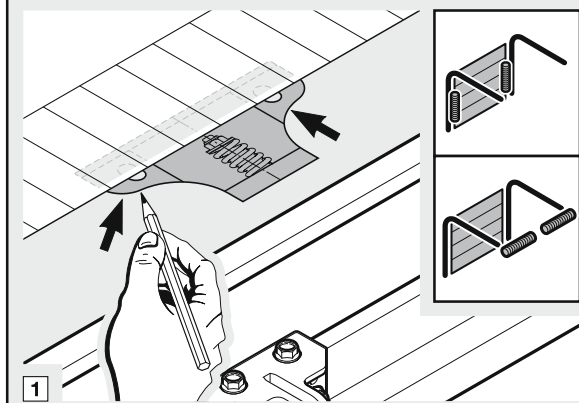
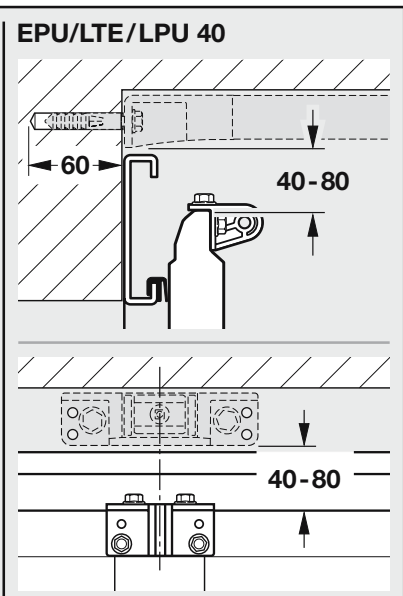
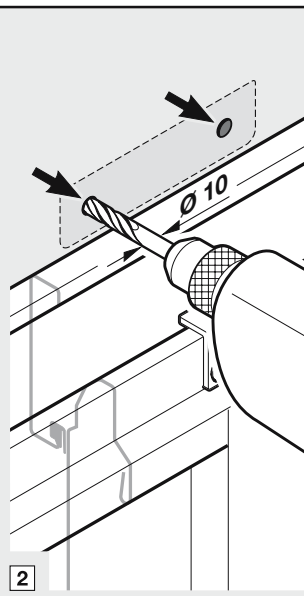
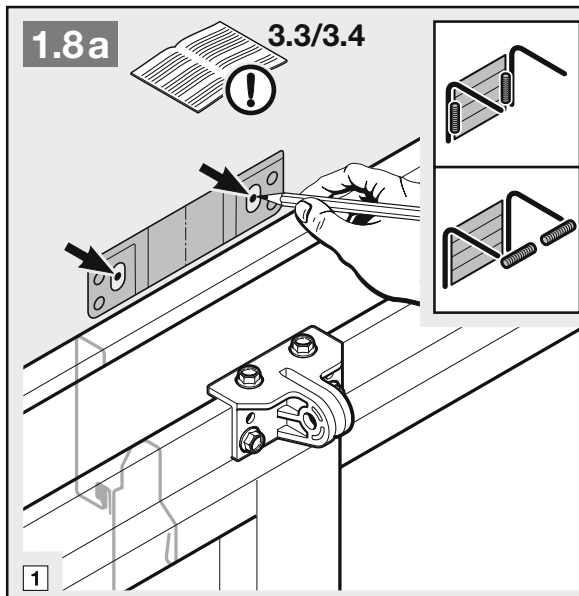
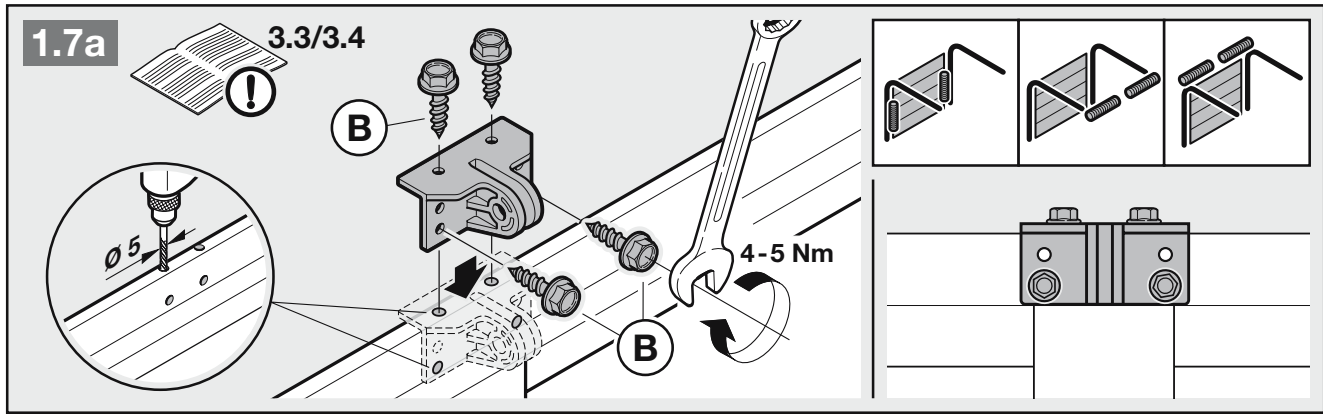

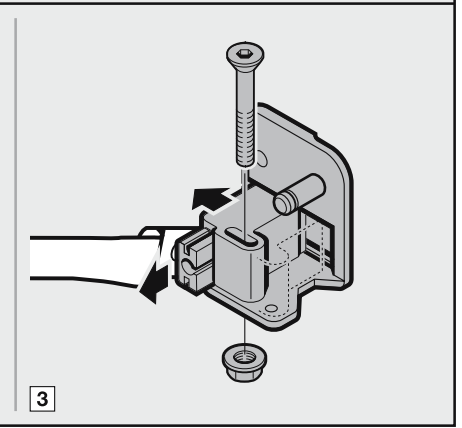
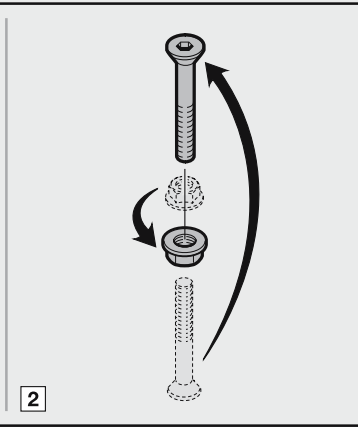
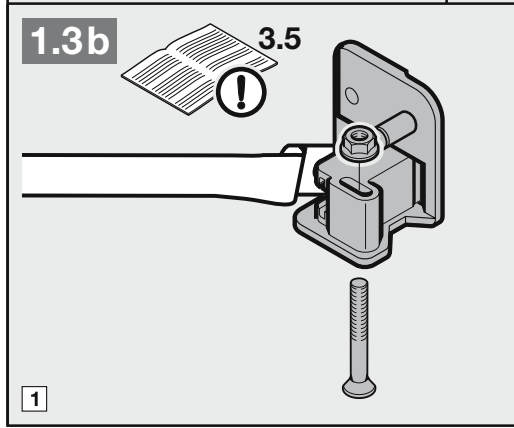
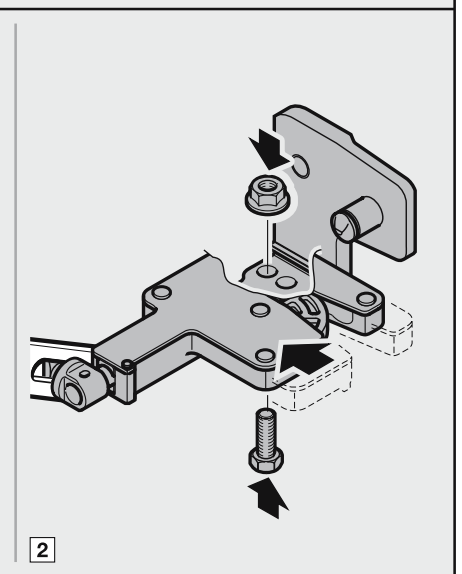
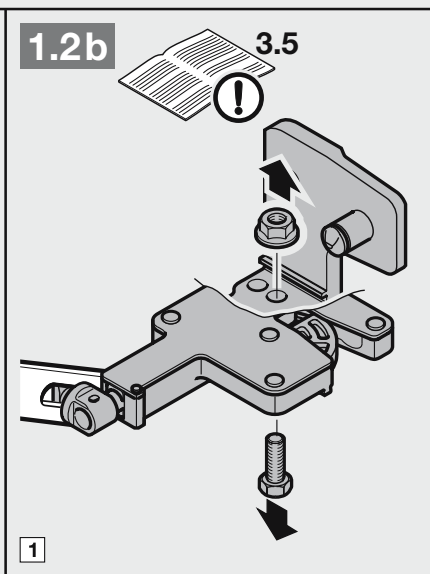
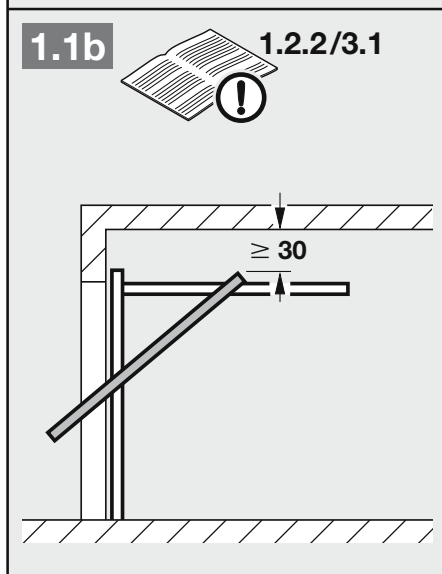
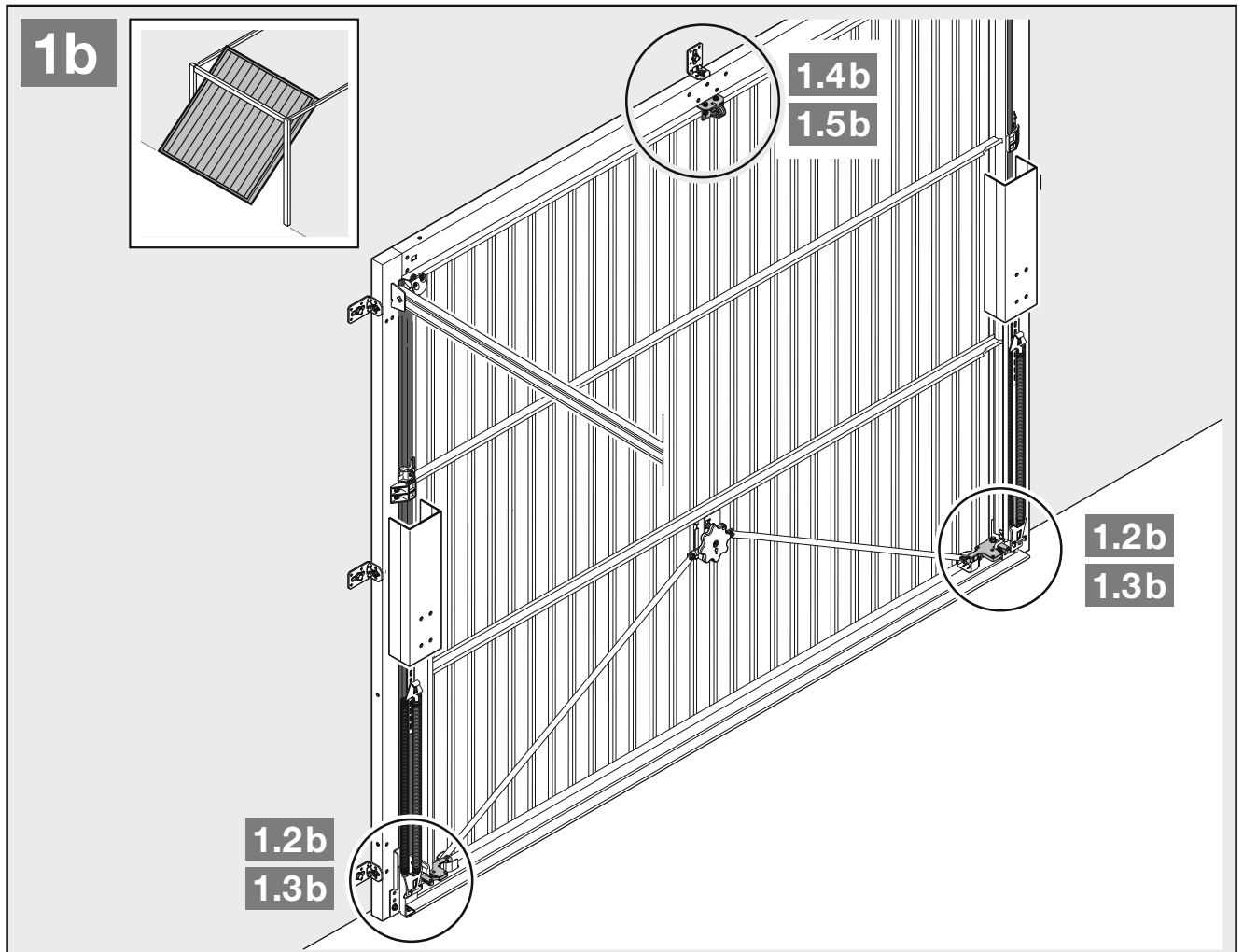

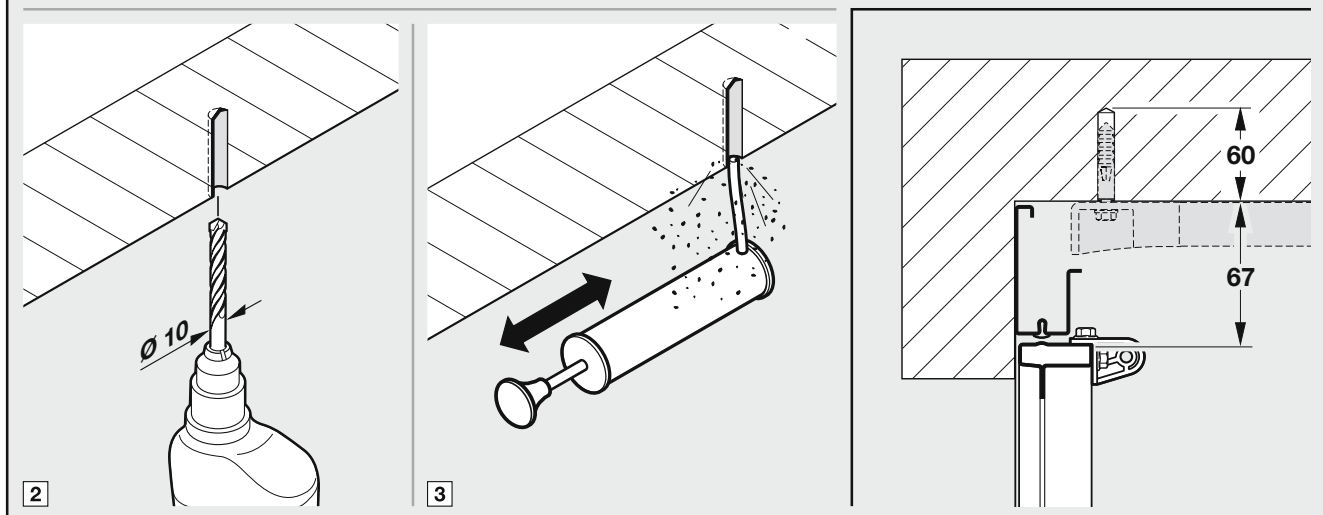
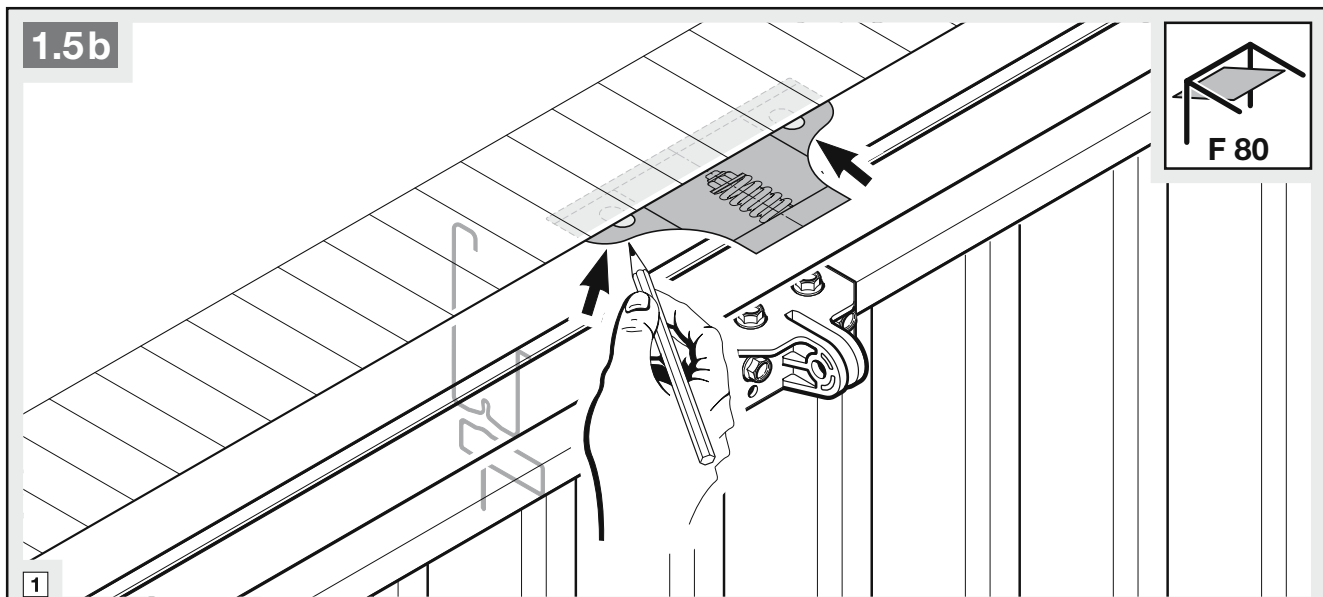
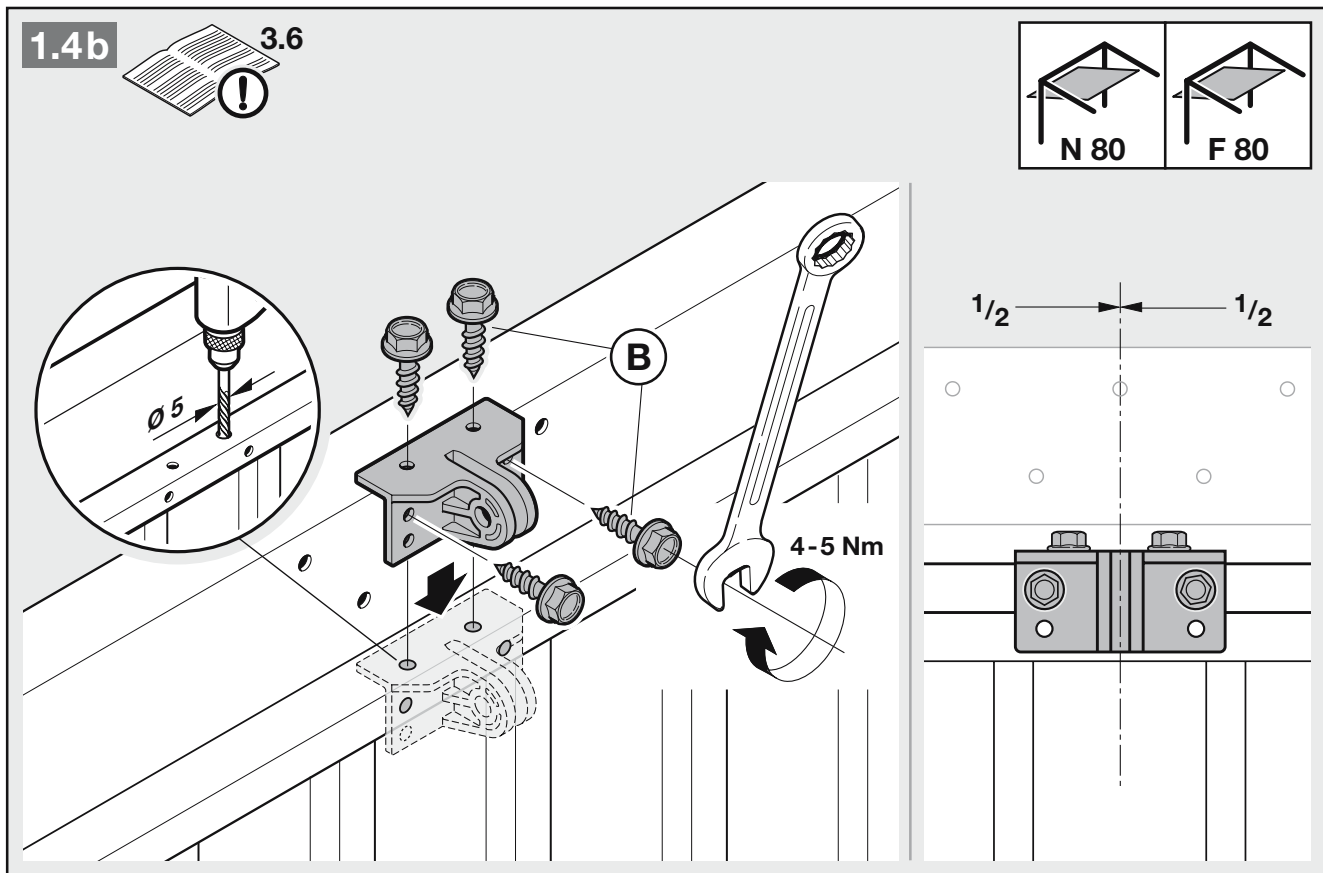

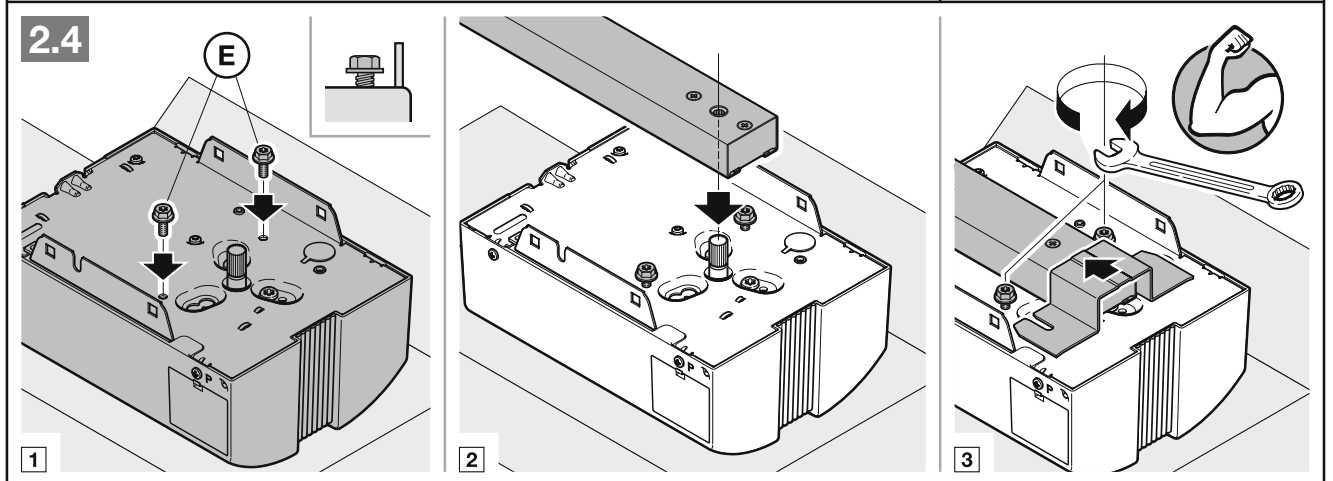
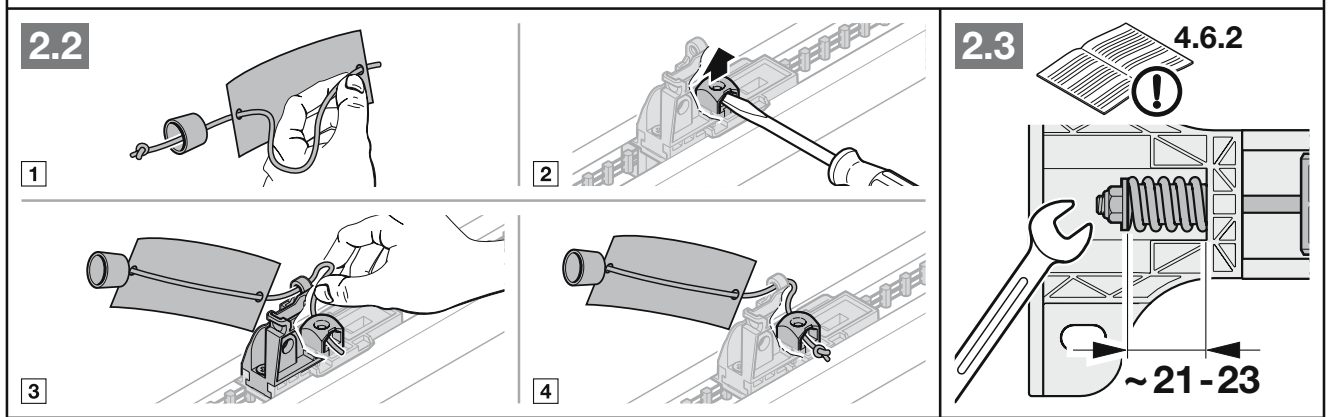
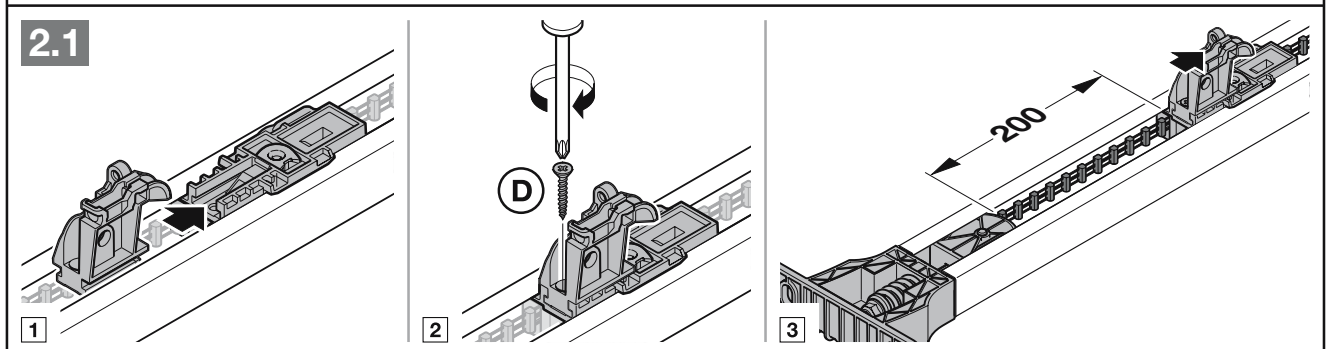
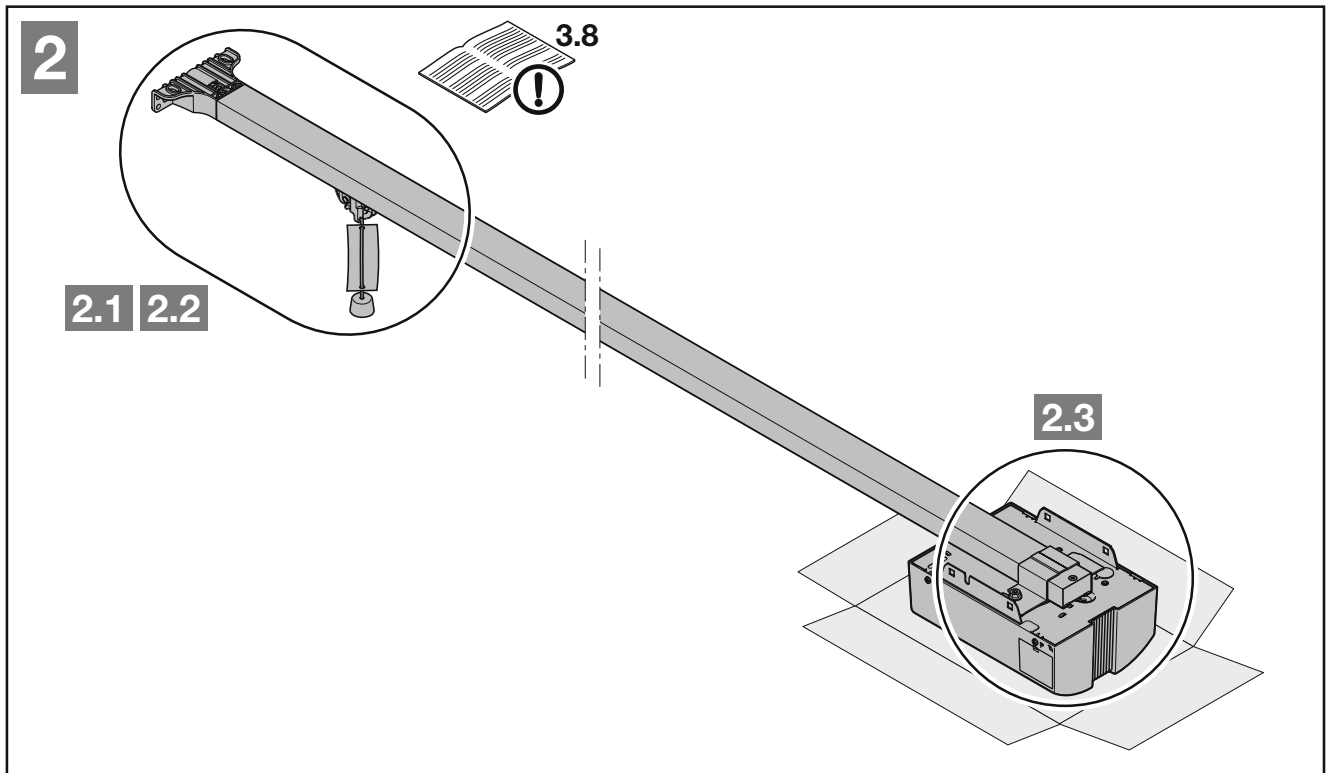

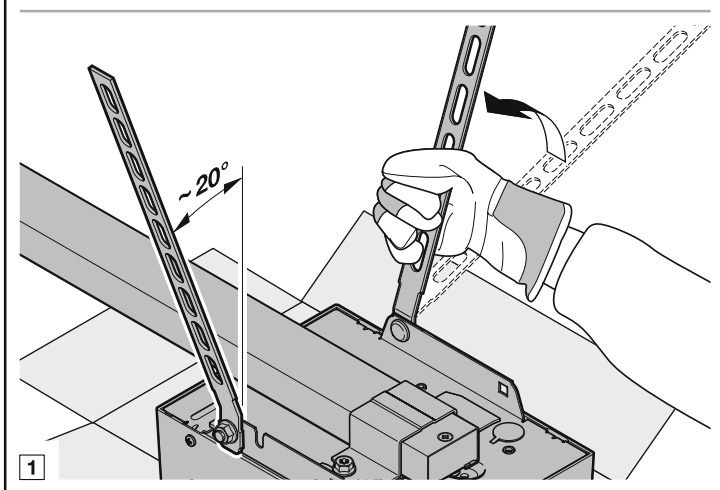
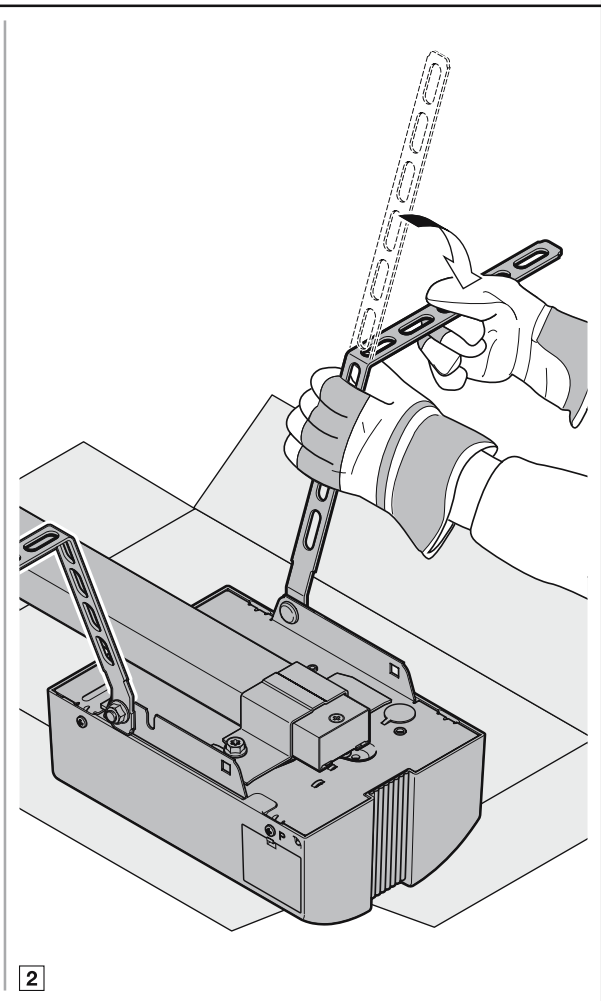
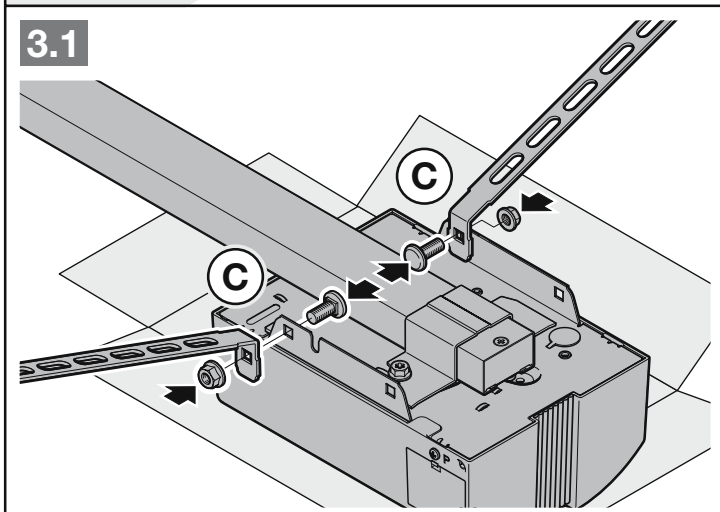
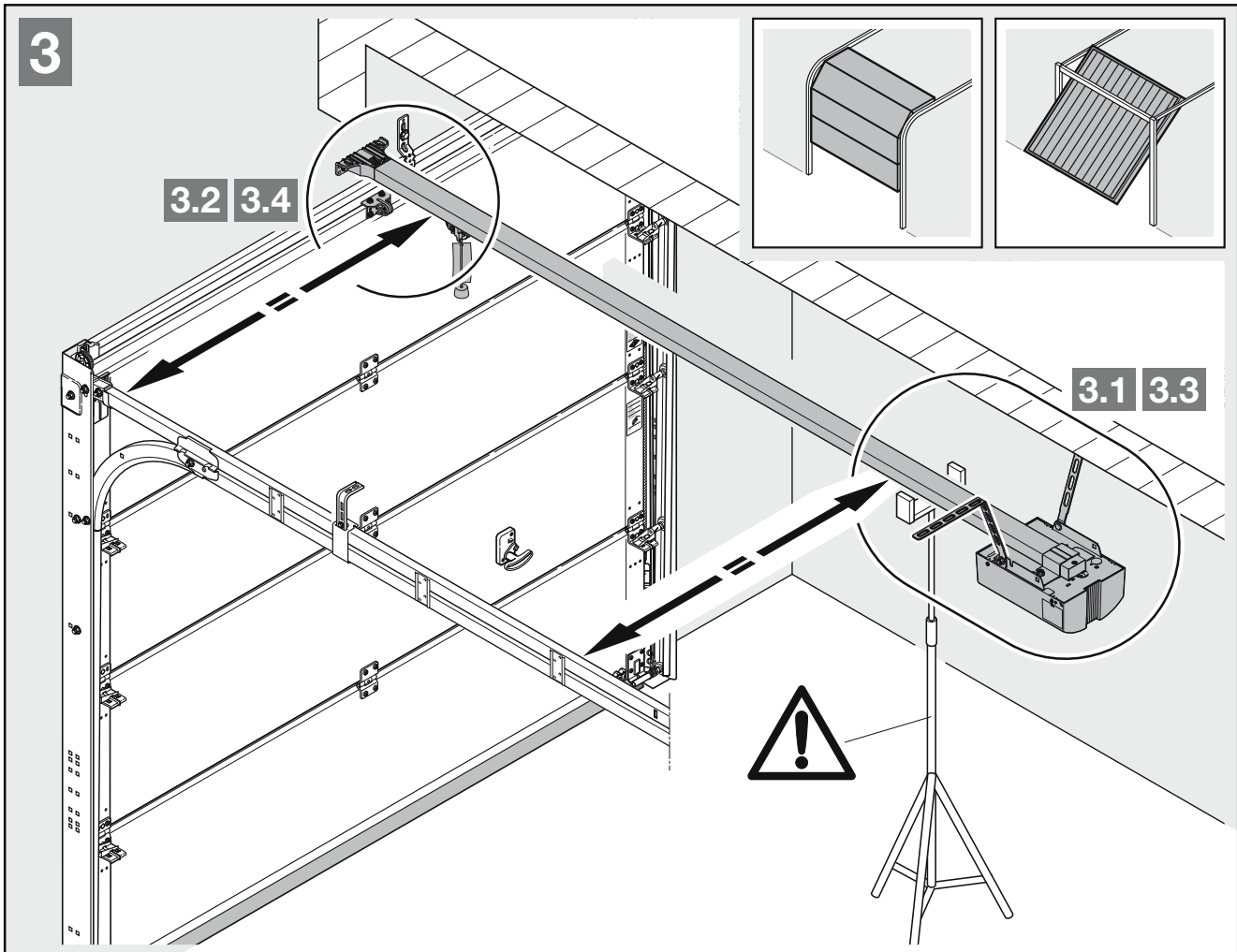

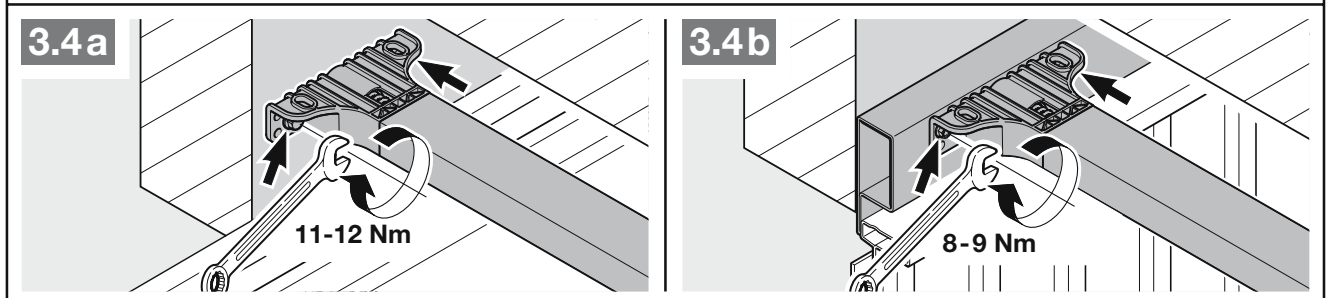
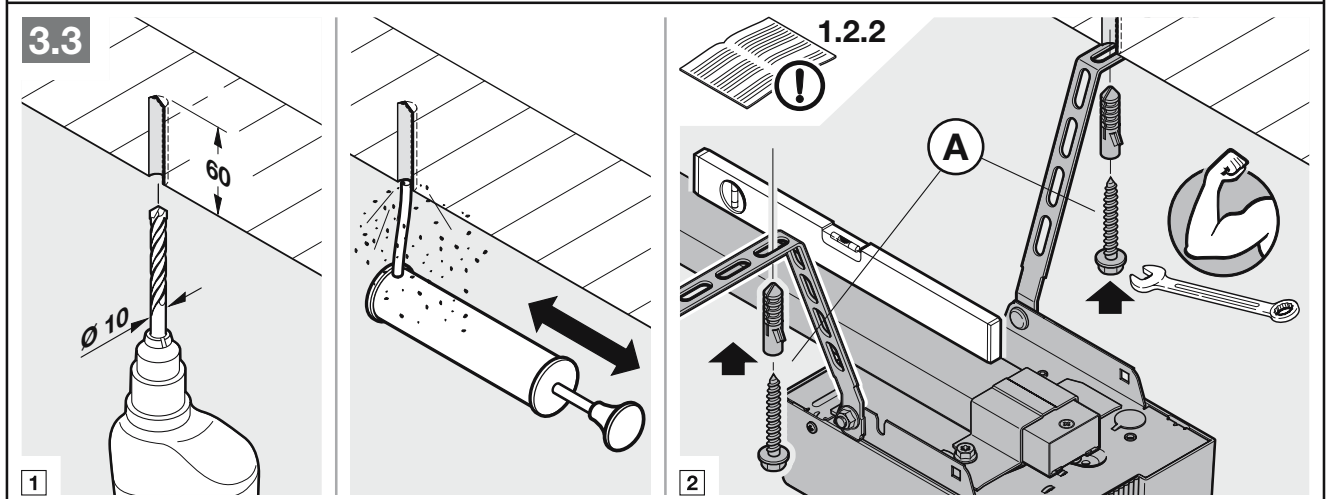
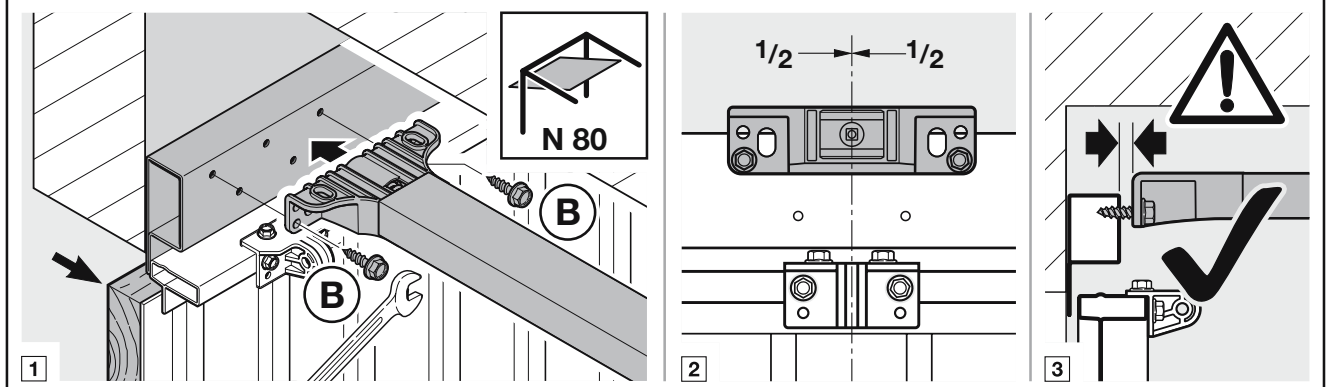
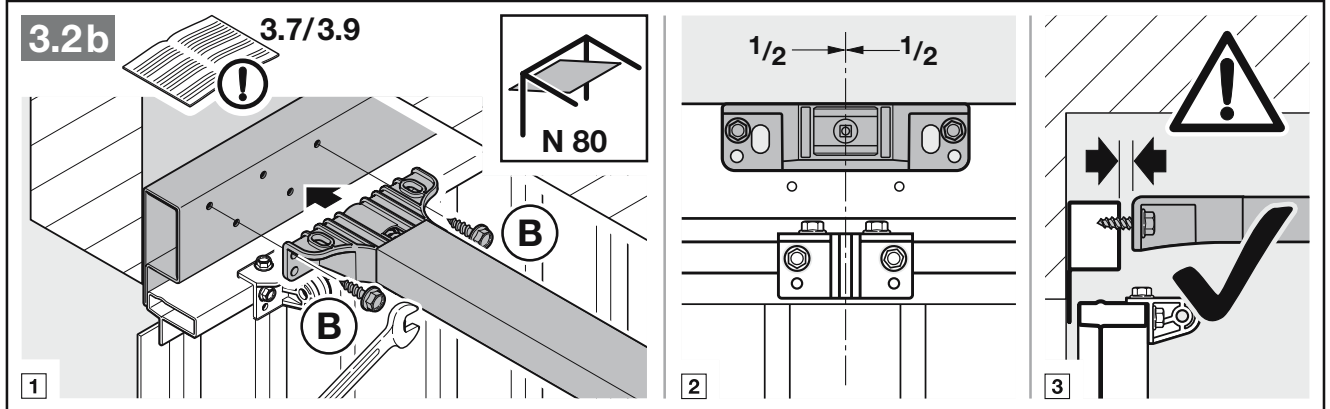
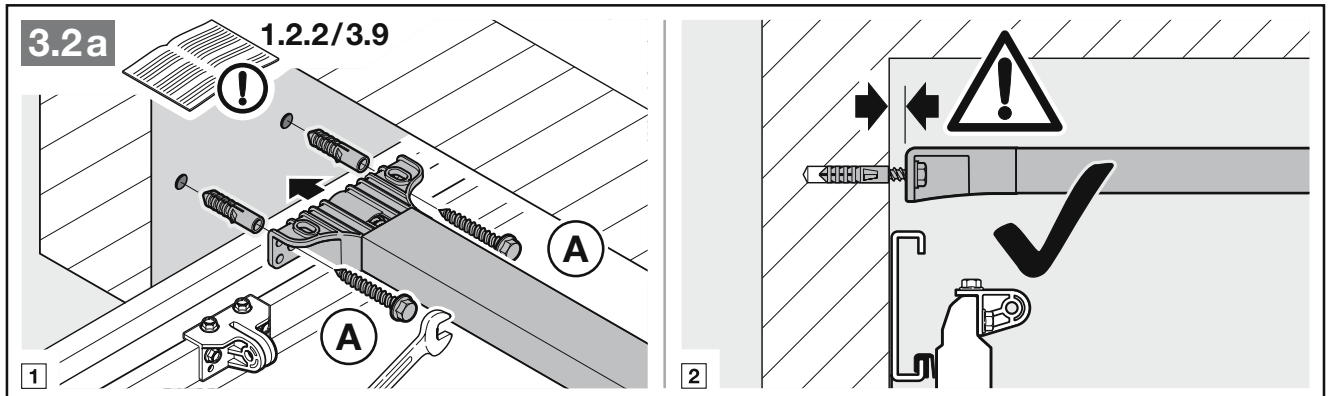

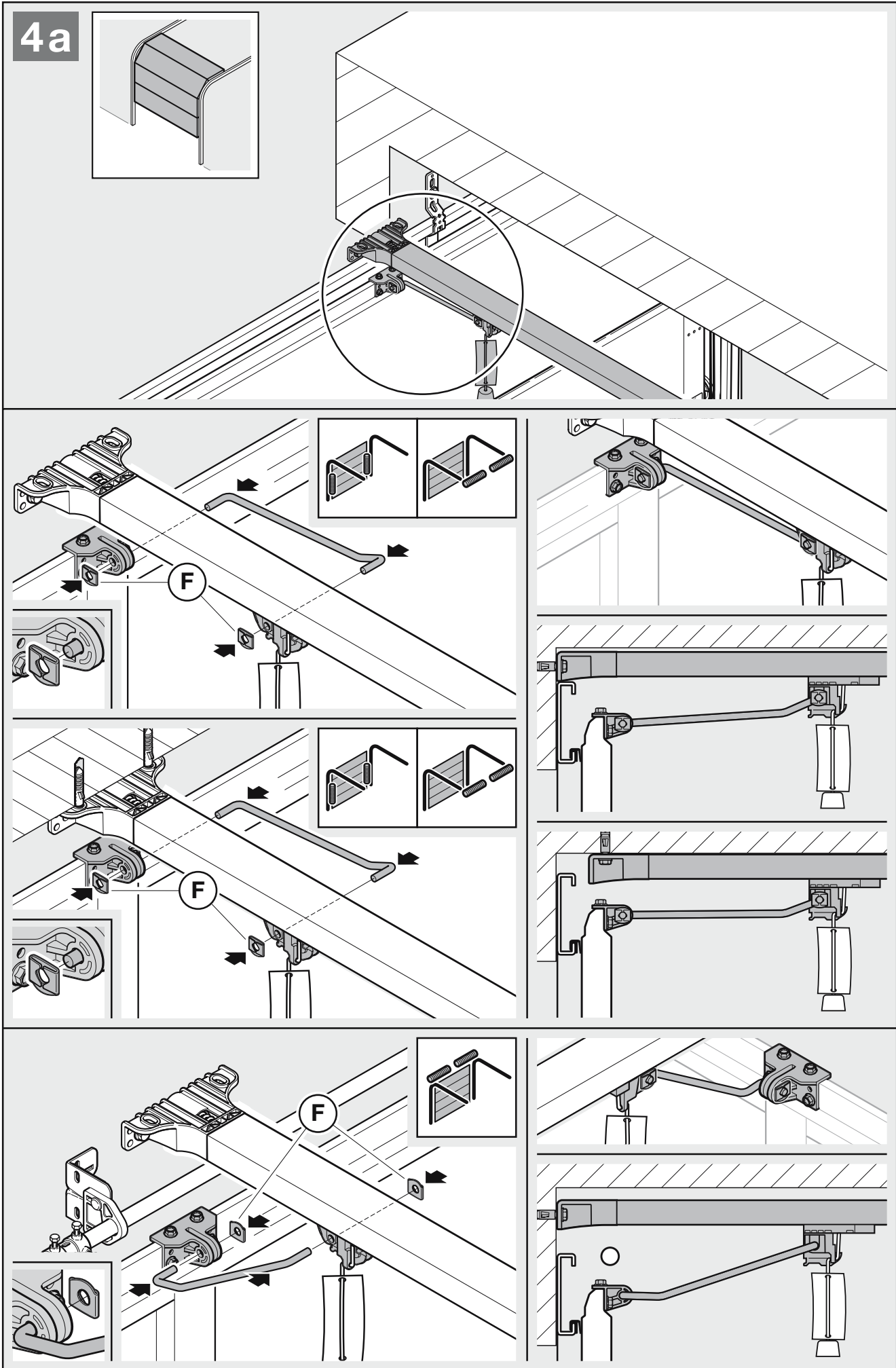

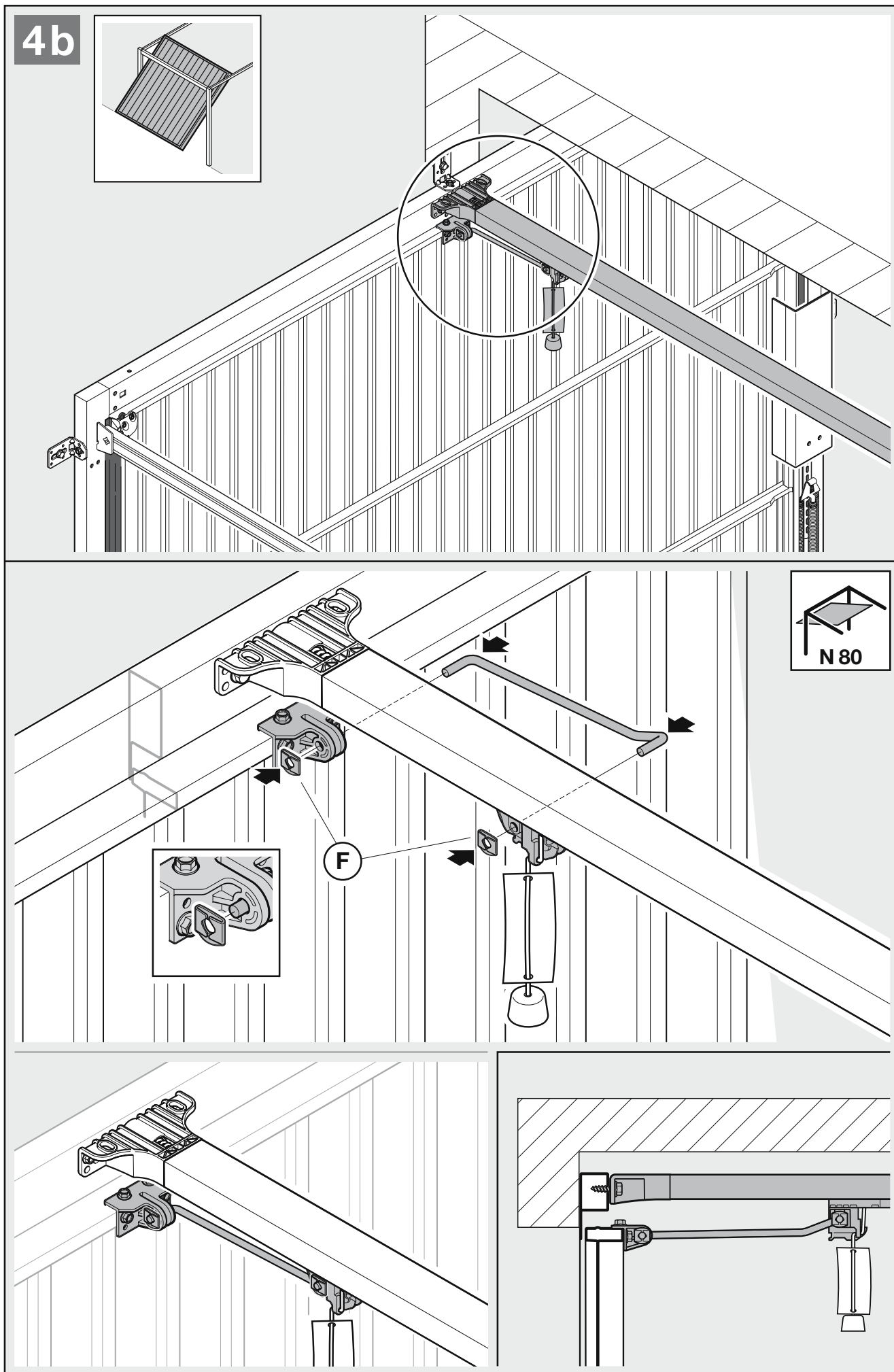

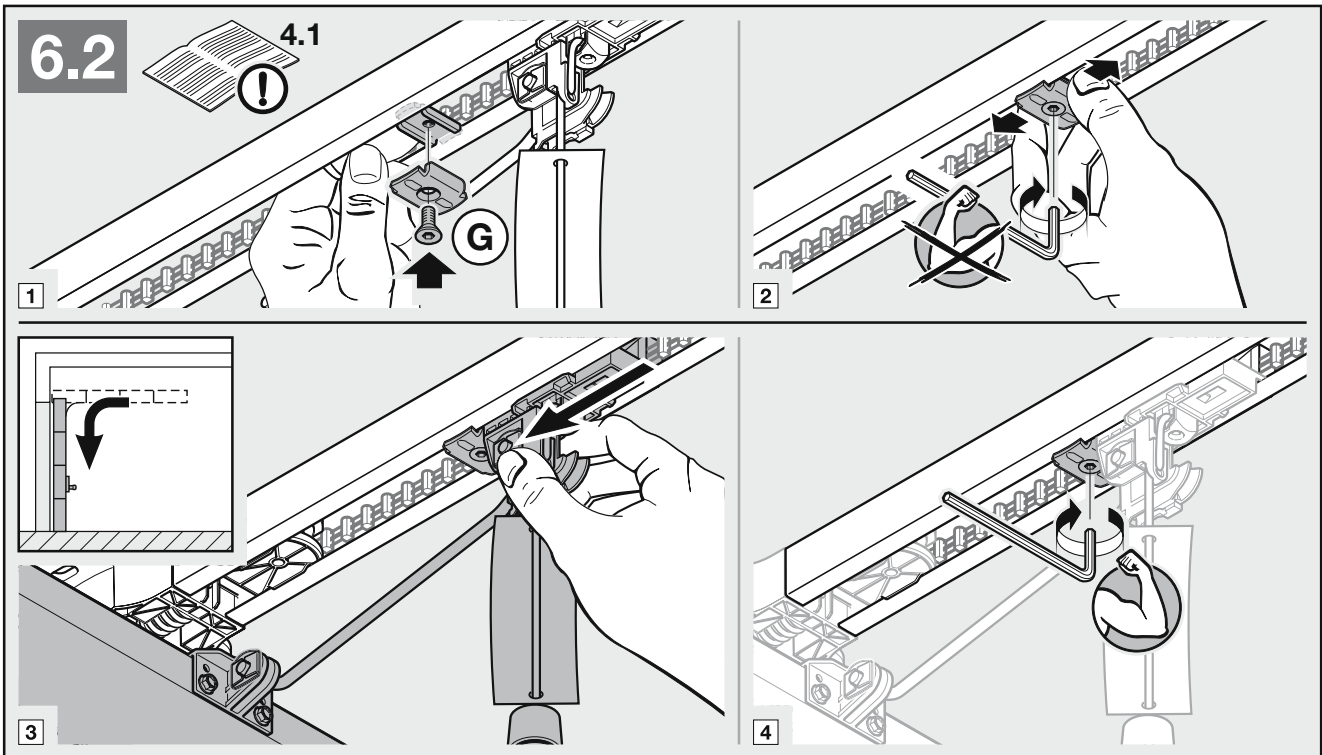
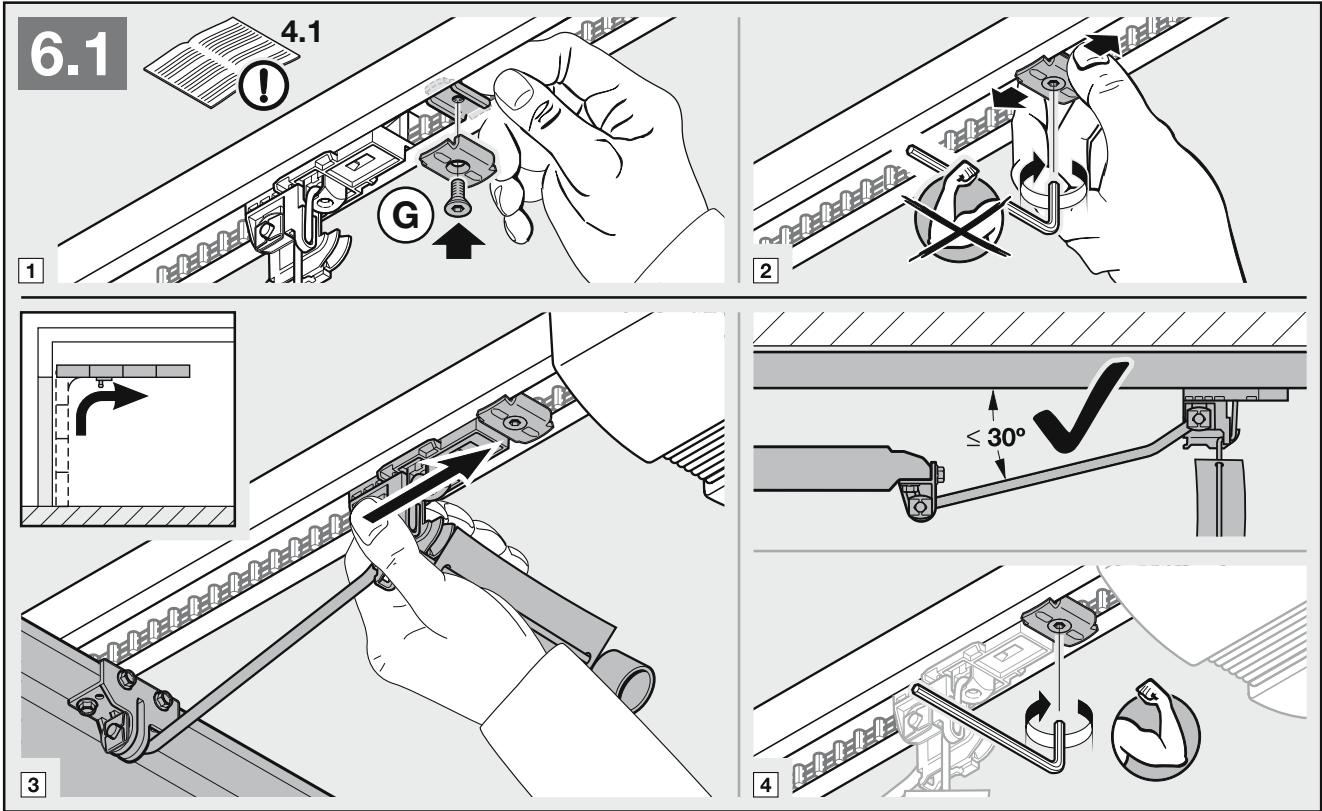
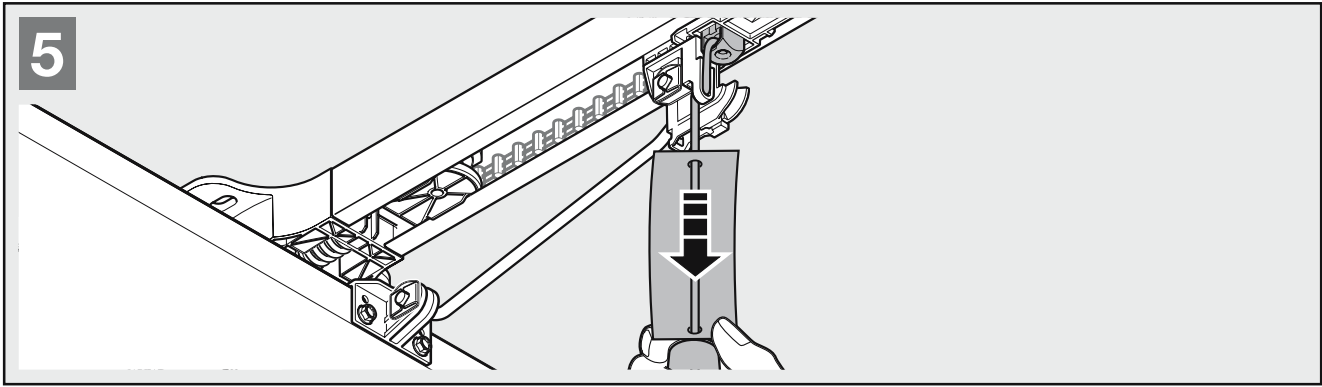

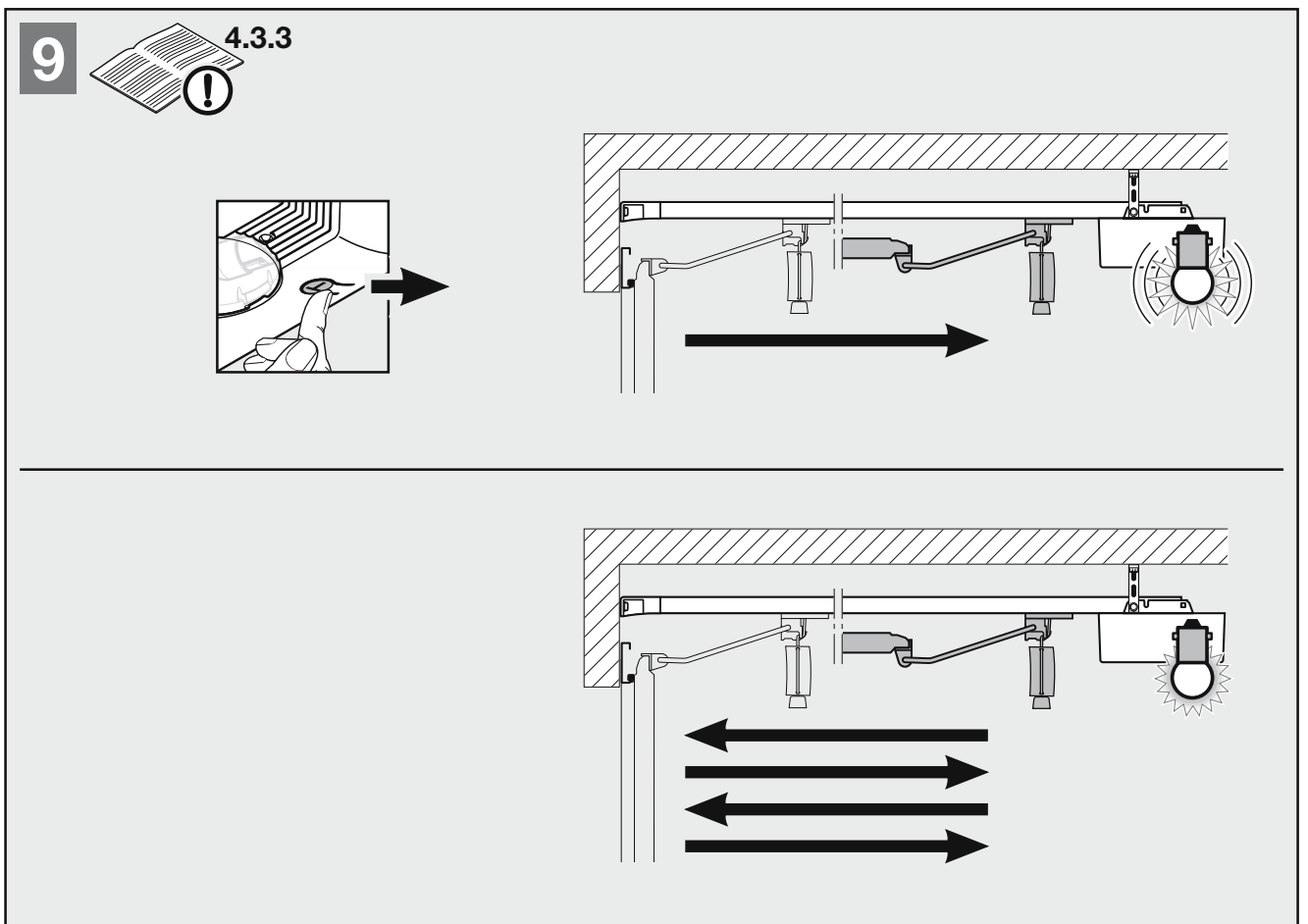
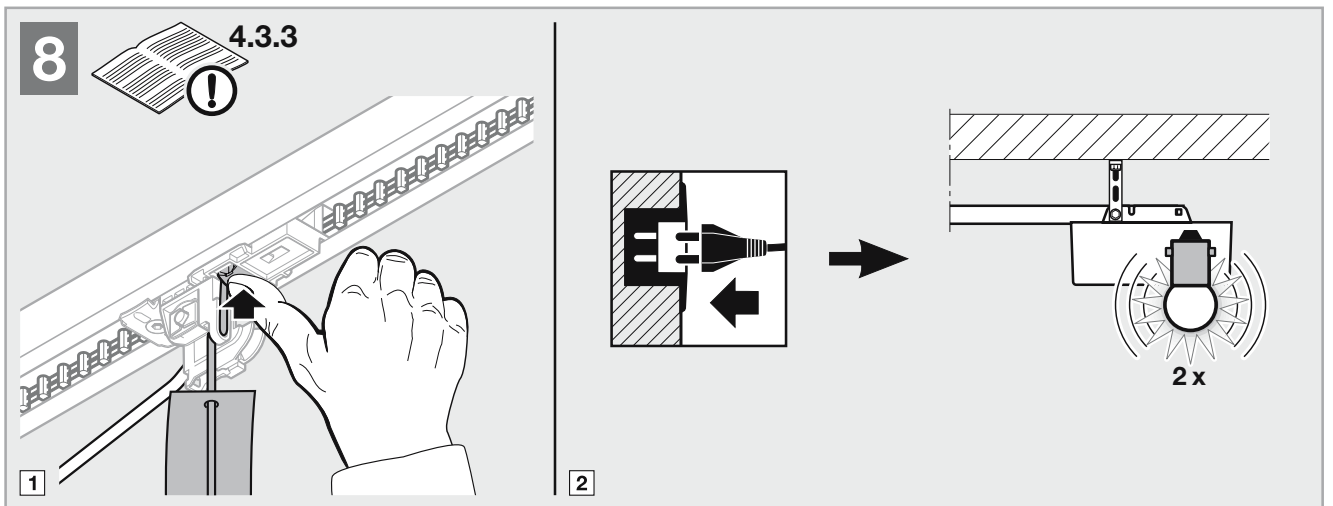
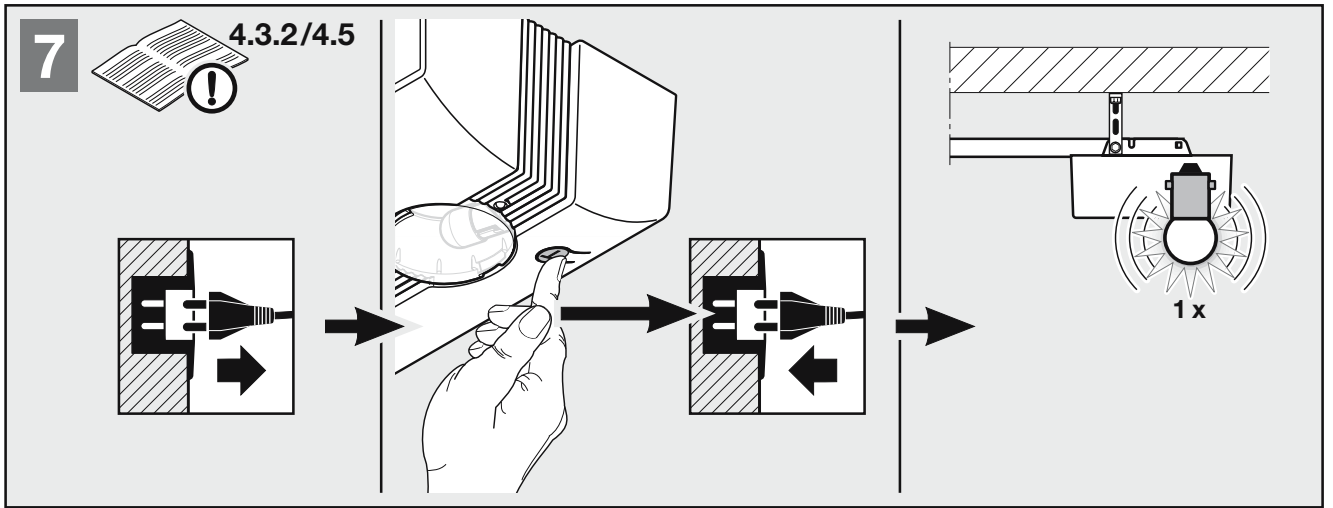

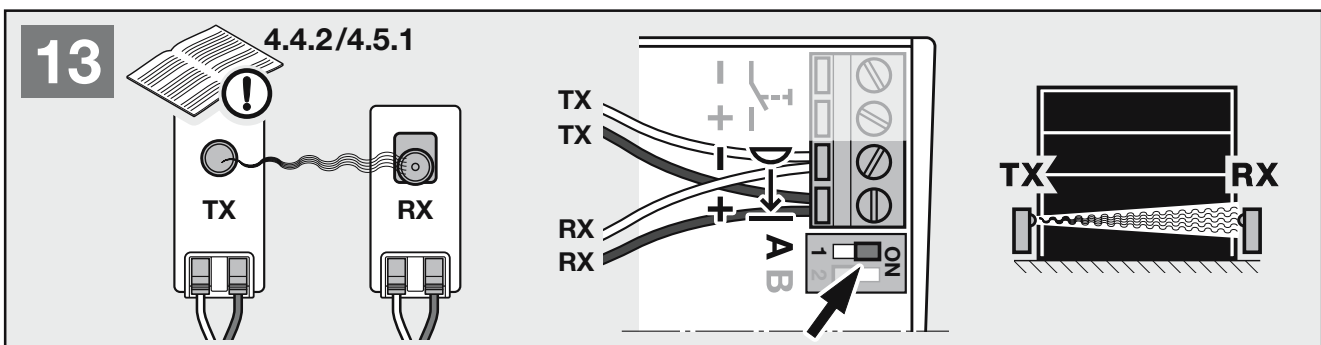
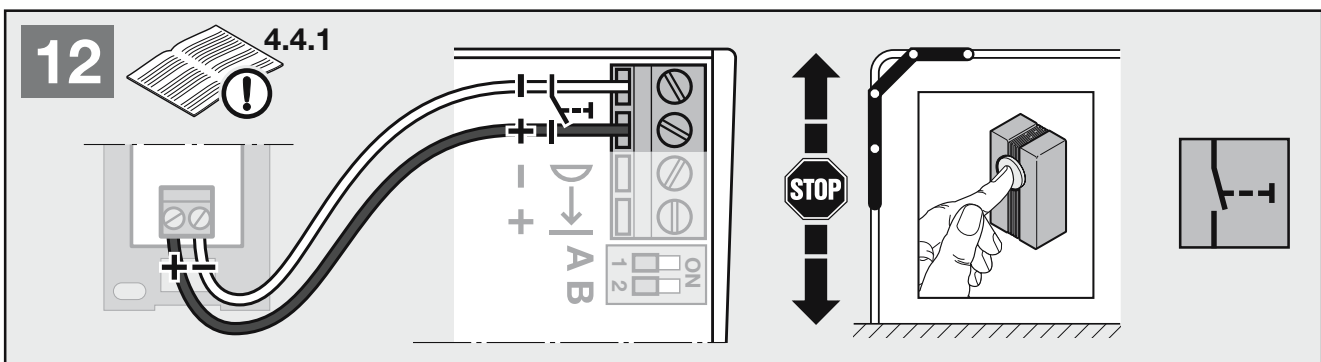
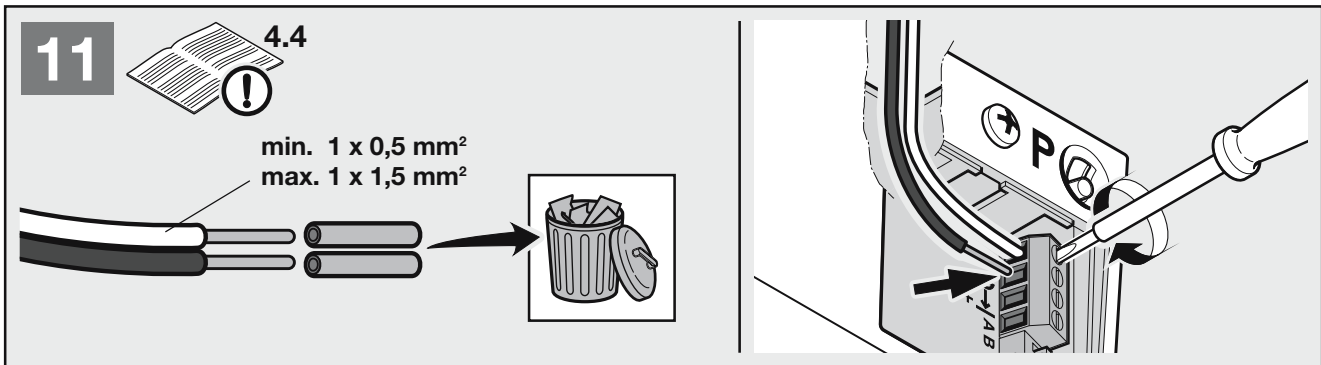
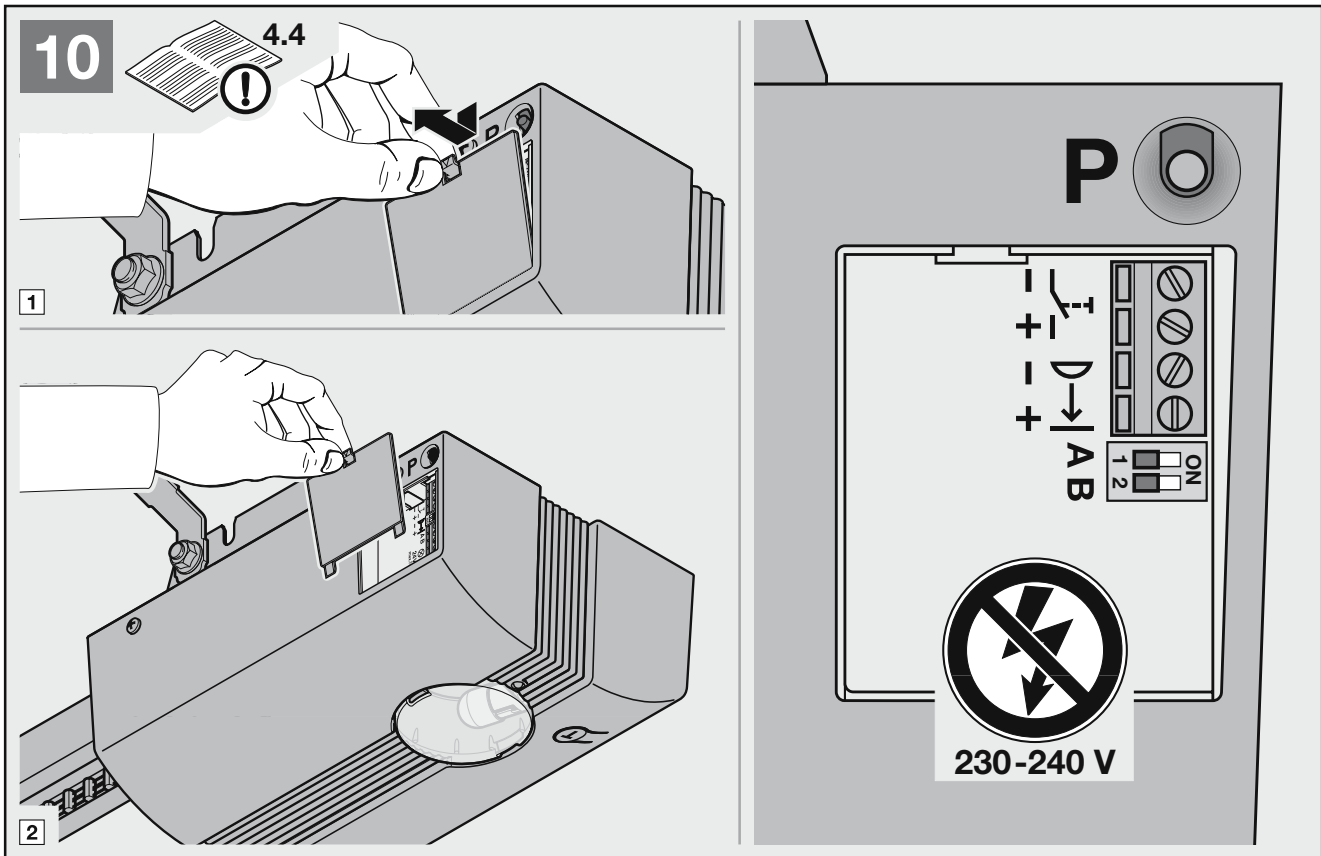

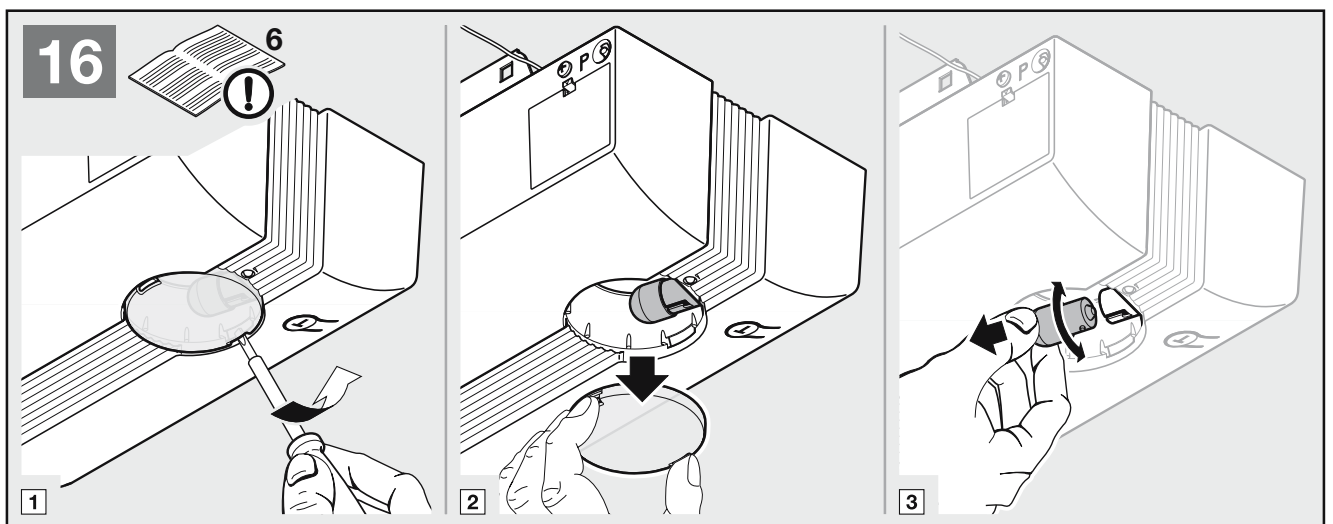
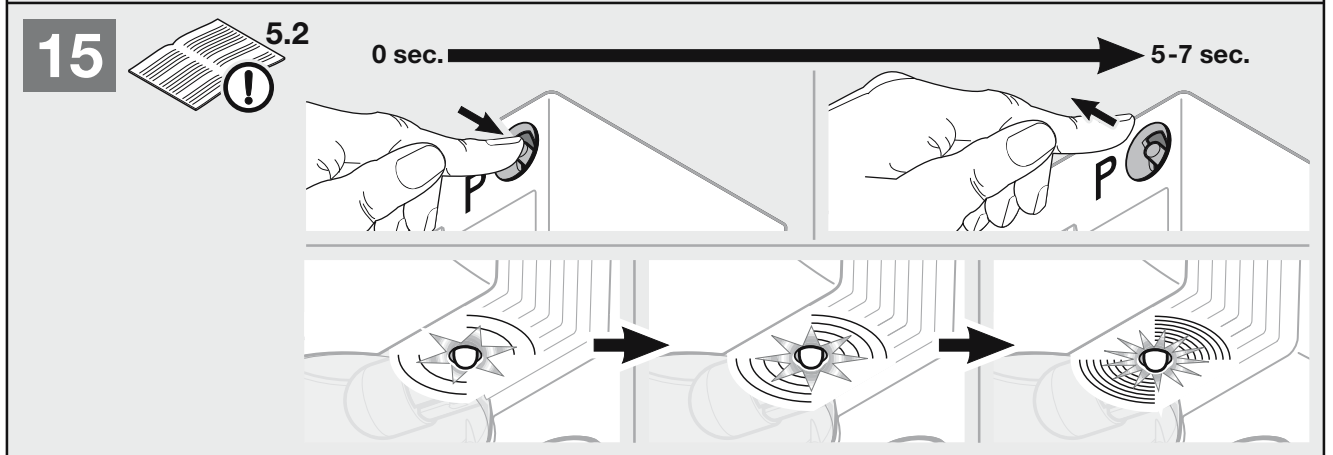
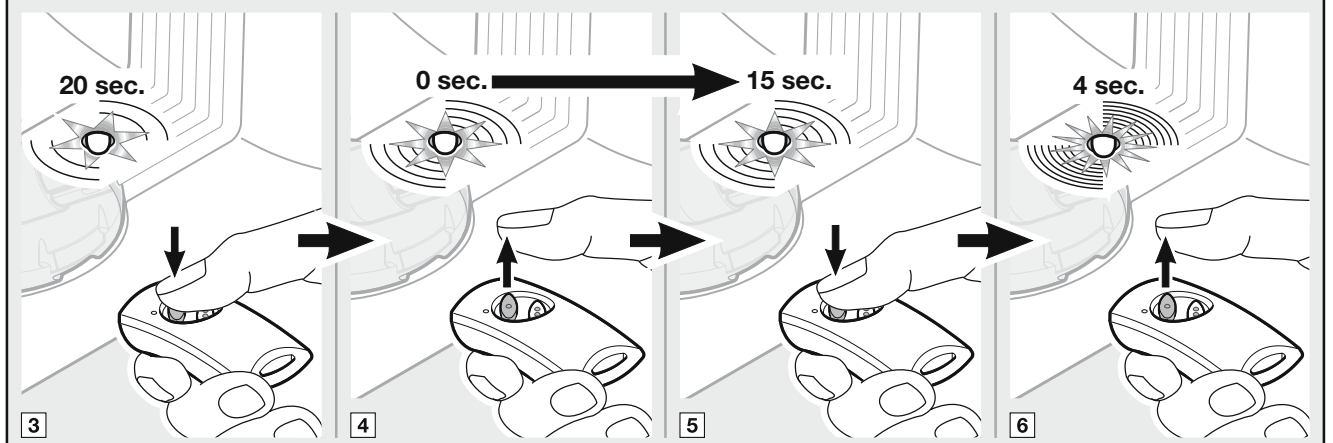
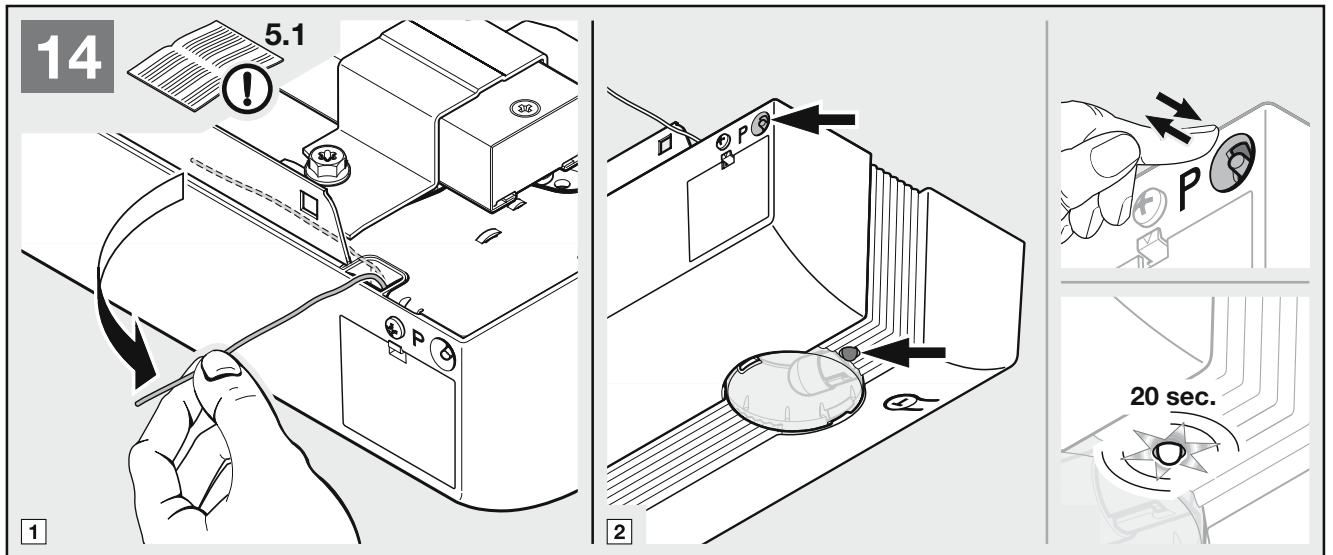

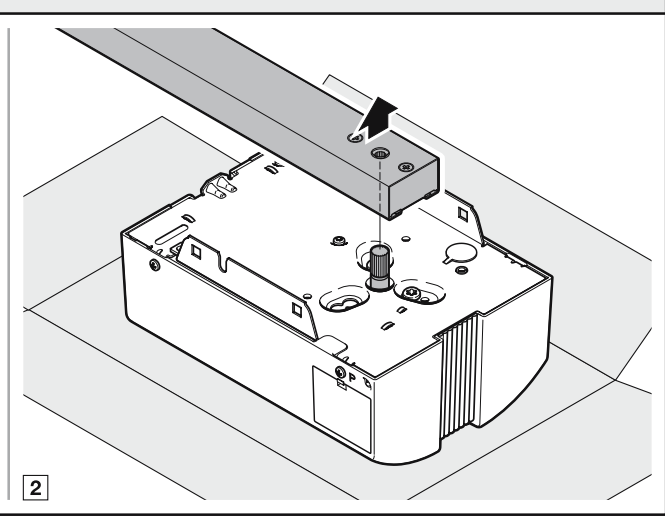
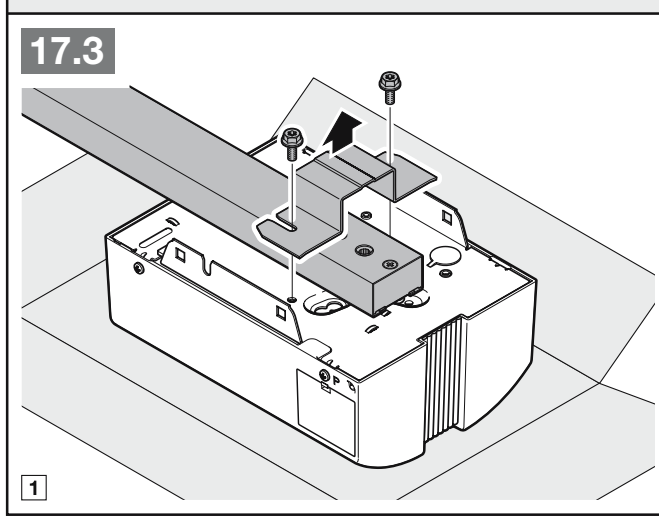
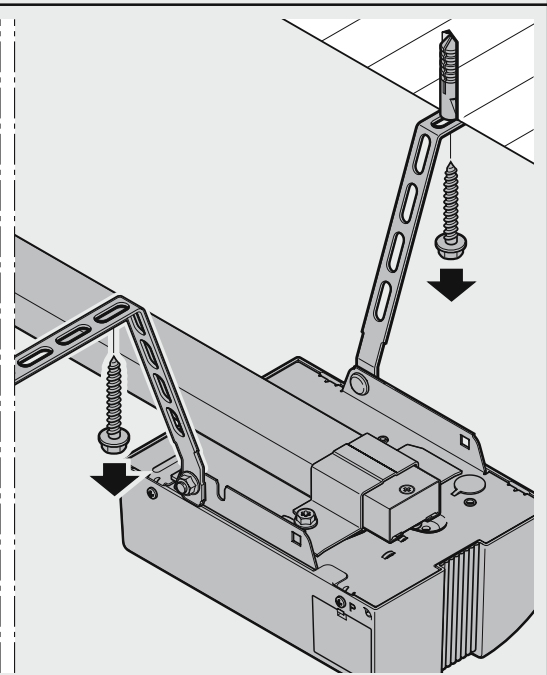
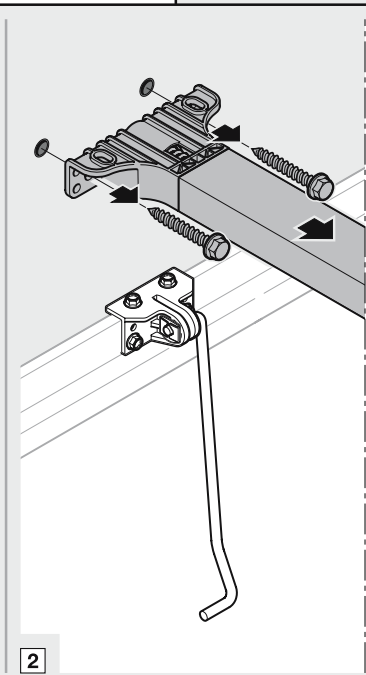
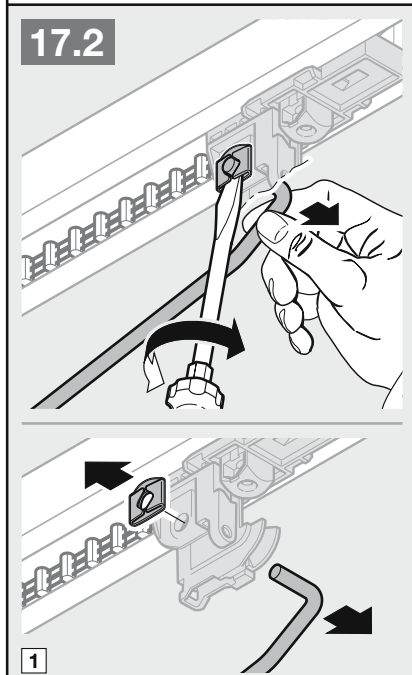
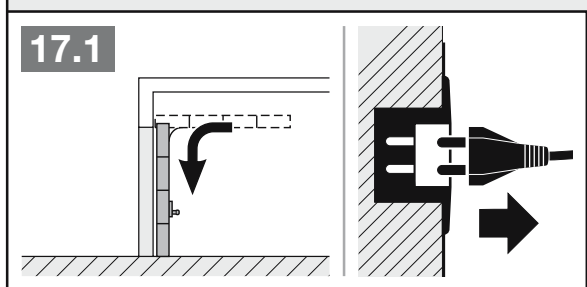
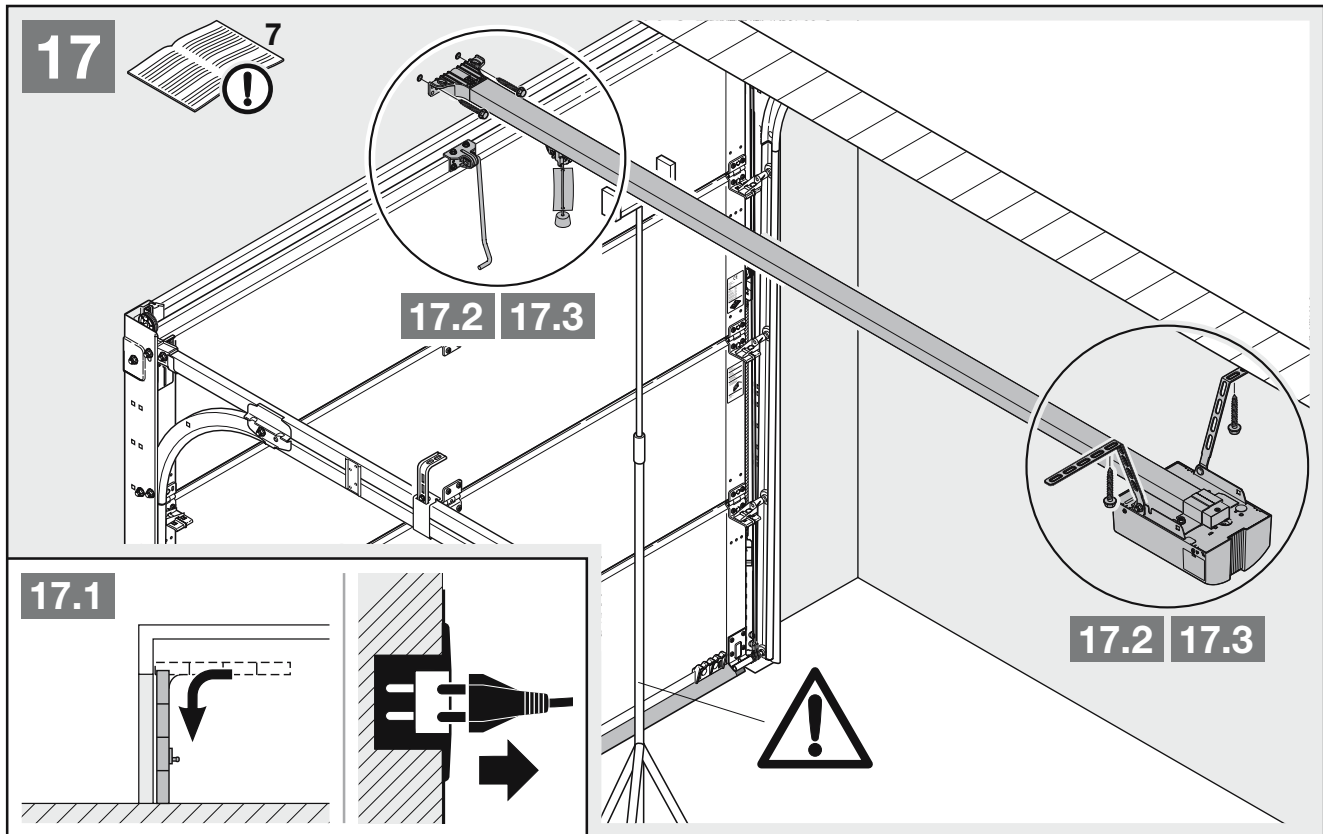

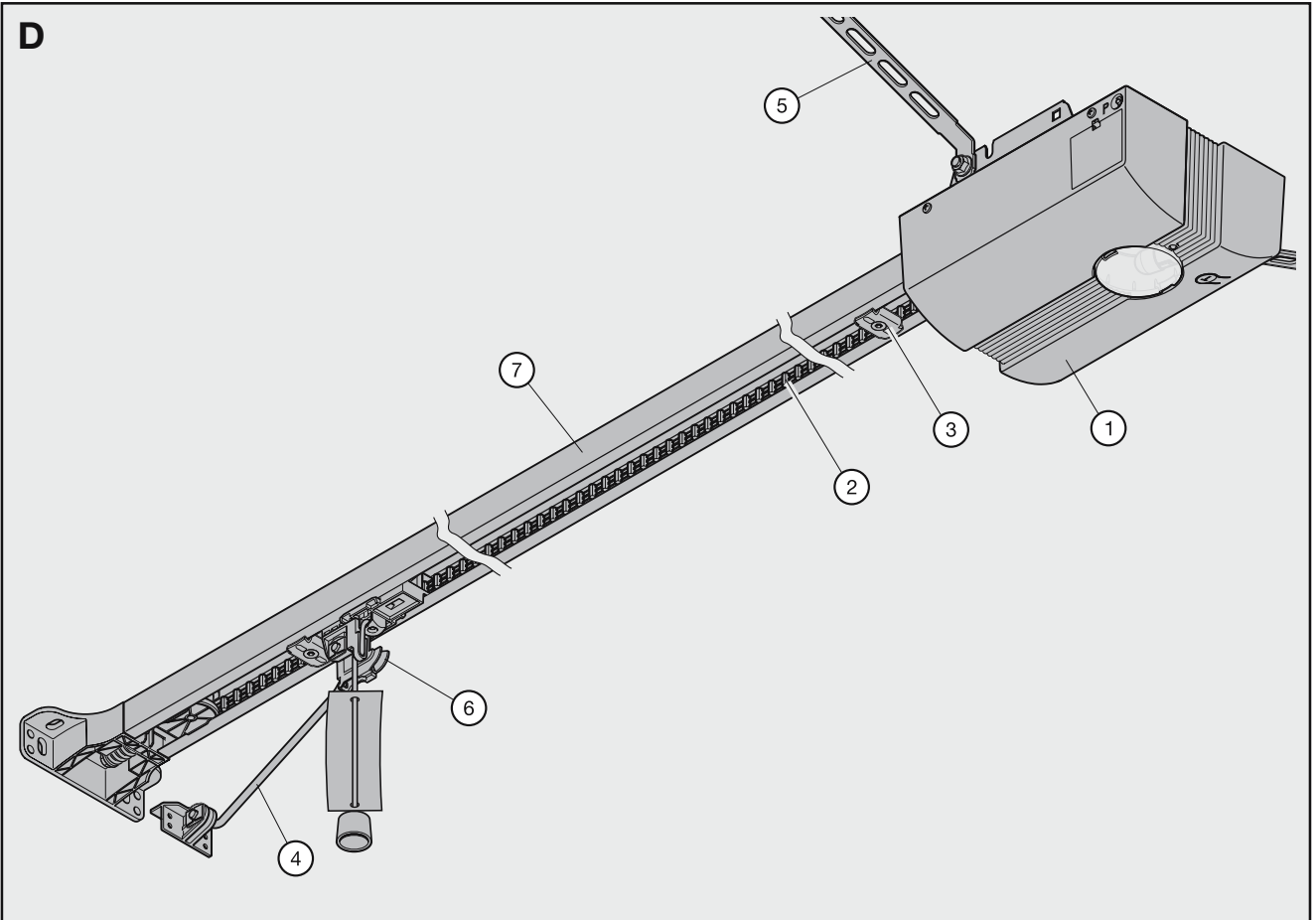

<p>1</p>		<p>1</p>
<p>2</p>		<p>1</p>
<p>3</p>		<p>1</p>
<p>4</p>		<p>1</p>
<p>5</p>		<p>1</p>

<p>6</p>		<p>1</p>
<p>7</p>		<p>1</p>

