

HOMENTRY

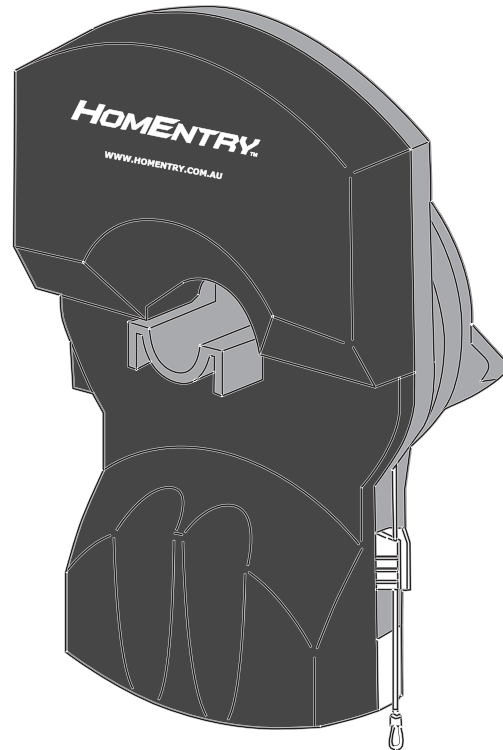

Installation and operating instructions for HomEntry garage door opener Model HE60R

Chamberlain Australia Pty Ltd
Phone toll free 1800 638 234
Fax toll free 1800 888 121

Chamberlain New Zealand Ltd
Phone toll free 0800 637 546
Fax toll free: 0800 653 663

www.homentry.com.au



N2966



This manual contains **IMPORTANT SAFETY** information.
DO NOT PROCEED WITH THE INSTALLATION BEFORE READING THOROUGHLY.



Start by Reading These Important Safety Instructions

WARNING: Failure to comply with the following instructions may result in serious personal injury or property damage.



- Read these instructions carefully and follow ALL instructions carefully
- The garage door opener is designed and tested to offer reasonable safe service provided it is installed and operated in strict accordance with the instructions in this manual.



These safety alert symbols mean **WARNING** – a personal safety or property damage instruction.

Read these instructions carefully.



Keep garage door balanced. Do not let the garage door opener compensate for a binding or sticking garage door. Sticking or binding doors must be repaired. Garage doors, door springs, brackets and their hardware are under extreme tension and can cause serious personal injury.



Do not wear rings, watches or loose clothing while installing or servicing a garage door opener.



To avoid serious personal injury from entanglement, **remove all ropes, chains and locks connected to the garage door** before installing the door opener.



Installation and wiring must be in compliance with your local building and electrical codes.



The safety reverse system test is very important. Your garage door **MUST** reverse on contact with a 40mm obstacle placed on the floor. Failure to properly adjust the opener may result in serious personal injury from a closing garage door. **Repeat the test once a month and make any necessary adjustments.**



This opener should not be installed in a damp or wet space.



Take care when operating the manual release as an open door may fall rapidly due to weak or broken springs, or being out of balance.



The drive must not be used on a wicket door (door within a door)



The Protector System must be used for all installations where the closing force as measured on the bottom of the door is over 400N (40kgf). Excessive force will interfere with the proper operation of the Safety Reverse System or damage the garage door.



After installation, ensure that the parts of the door do not extend over public footpaths or roads.



Disengage all existing garage door locks to avoid damage to garage door.



Install the wireless wall control (or any additional wall control) **in a location where the garage door is visible, at a height of at least 1.5m and out of the reach of children. The appliance is not intended for use by young children or infirm persons without supervision.** Serious personal injury from a closing garage door may result from misuse of the opener.



Permanently fasten the **Warning Label** adjacent to the wall control **in a Prominent Place** as a reminder of safe operating procedures.



Activate opener only when the door is in full view, free of obstructions and the opener is properly adjusted. No one should enter or leave the garage while the door is in motion.



Do not allow children to play near the door.



Disconnect electric power to the garage door opener before making repairs or removing covers.

SAVE THESE INSTRUCTIONS

Warning: If your garage has no service entrance door, a CM1702 outside quick release must be installed. This accessory allows manual operation of the garage door from outside in case of power failure.

1 Carton Inventory

1. Instruction manual (this document)
2. Stop bracket collar
3. Clamp bracket
4. Release handle and cord
5. Remote controls (2)
6. Extension poles (2)
7. Weight bar
8. Bracket plate
9. Hardware bag
10. Warning Labels (2)

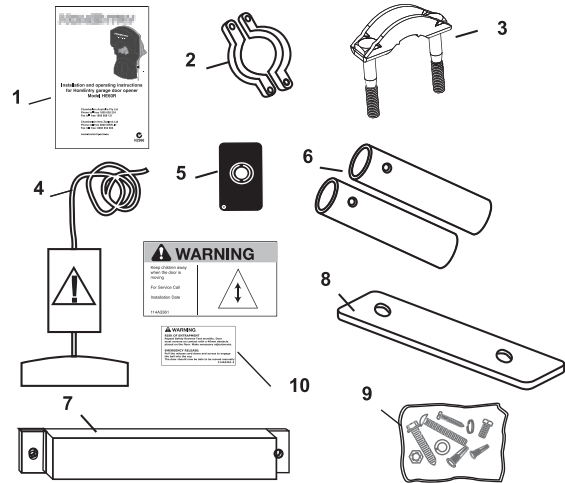

2 Tools Required

1. Ladder (or similar device to safely support door weight)
2. Adjustable wrench for U-bolts already installed on the door
3. 8mm socket, 10mm socket and 13mm extended socket and socket wrench
4. 30mm socket extension (for minimum sideroom installations)
5. Drill and 5.5mm drill bit
6. Philips screw driver
7. Marker Pen

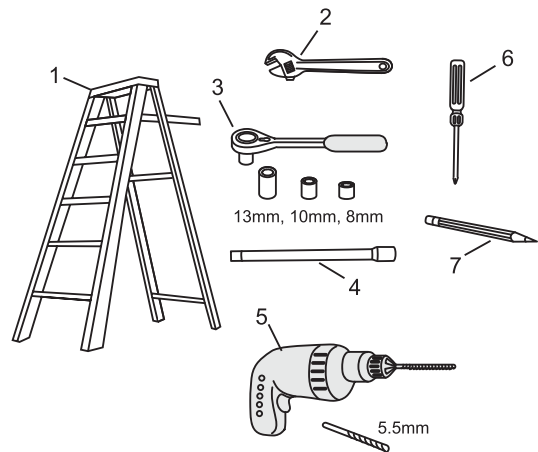

3 Door Requirements

The maximum allowable door height is 3.5m with a maximum curtain area of 8m² (door height in metres multiplied by the width in metres).
The maximum allowable door weight is 60kg.

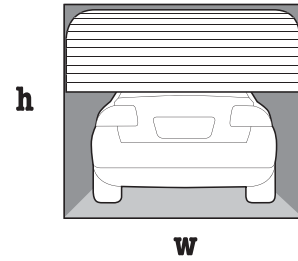

Door area;
 $h \times w = m^2$
eg. $2.5 \times 3 = 7.5m^2$

Typical side room installation

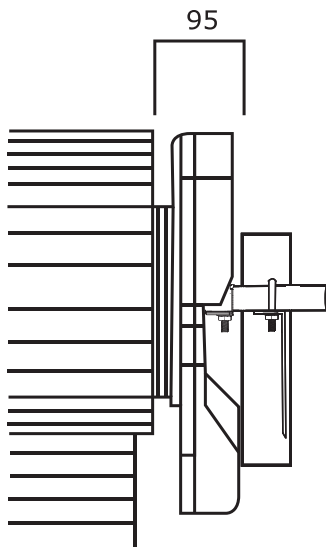

Minimum side room installation

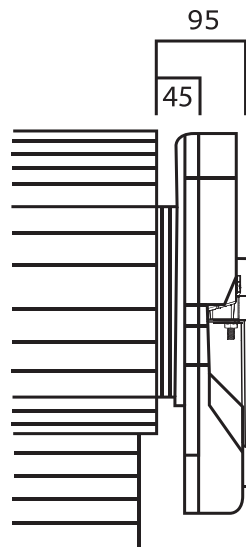

Ensure that there is at least 45mm from the edge of the curtain to the edge of the bracket. If the roller door drums are on the edge of the curtain or are of small diameter additional clearance maybe required.

If the drums are more than 60mm from the curtain edge or of small diameter extension poles maybe required.

Different drum and bracket types may result in the minimum side room clearance not being possible and extension poles being required. Ensure there is a power point near the opener.

4 Testing the door

Disable all locks and remove any ropes connected to the garage door.

Complete the following test to ensure your door is well balanced, and not sticking or binding:

- Lift the door to about halfway and then release it. The door should remain suspended entirely by its spring.
- Raise and lower the door to discover if there are any sticking or binding points.
- If your door spring does not hold the door in place or the door binds or sticks, call a qualified door technician before automating the door.

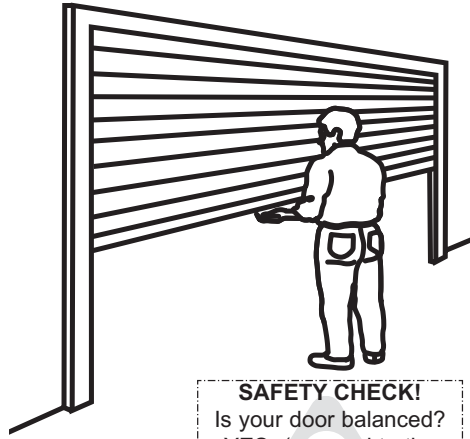

SAFETY CHECK!

Is your door balanced?
YES (proceed to the next step)

NO (Contact a garage door service technician before proceeding).

5 Installing the stop collar

- Install stop bracket collar on the opposite end to where the opener is to be installed.
- Fit the stop bracket hard against the boss of the door drum. Ensure the U-bolt holding the door shaft to the door bracket is tightly secured.

Non motorised side

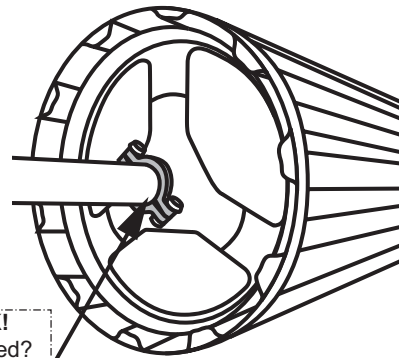

SAFETY CHECK!

Is stop collar installed?
YES (proceed to the next step)

NO (install the stop collar before proceeding).

6 Installing the weight bar (provided)

- Place the weight bar in the centre of the door.
- Use a Pencil to mark the two hole positions.
- Drill two 5.5mm holes through the two marked position, then place the weight bar on the inside of the door.
- Use the 5mm bolts, washers and nuts (provided) to fasten the weight bar in place.

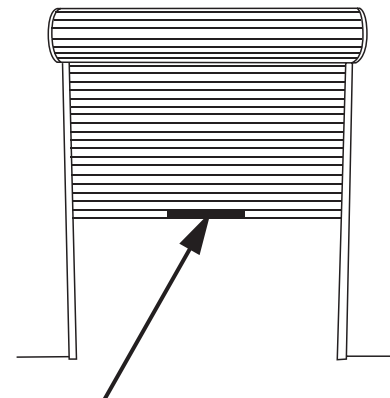

7 Preparing the Opener

Set Opener Position (Left or Right hand)

For **left hand side** installations the wire jumper **should be removed**.

For **right hand side** installations the wire jumper **should be in place** (factory installed).

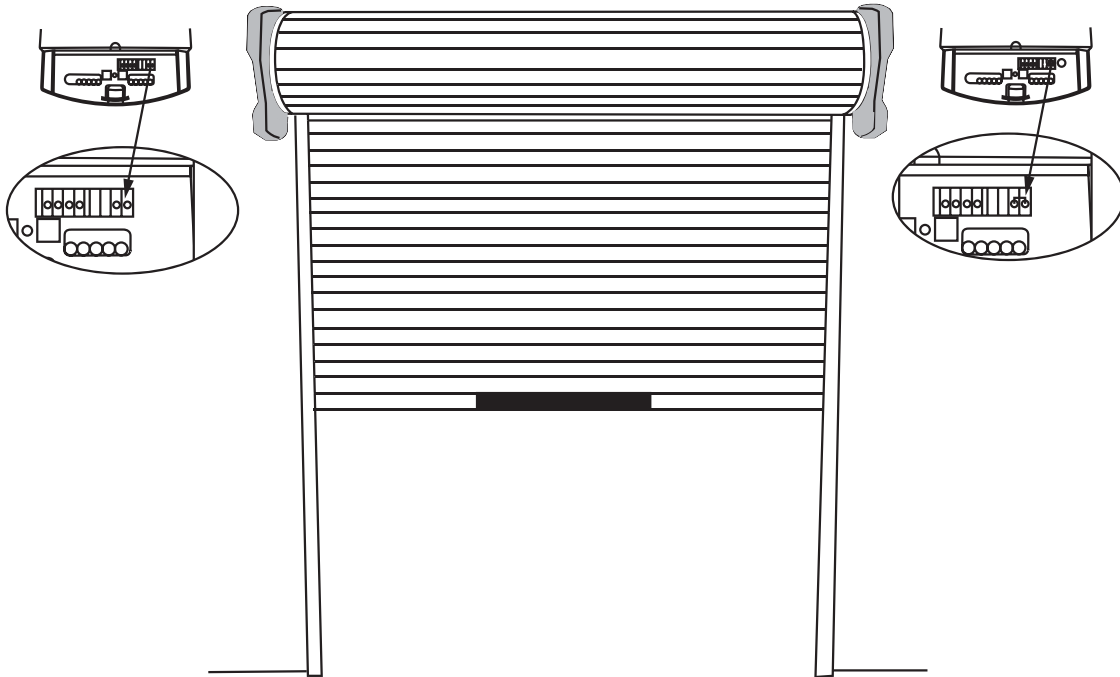

Attaching the Extension Poles (if required)

- Insert the extension poles into the gear.
- Align the extension pole holes with the gear holes.
- Using the supplied screws secure the extension poles.

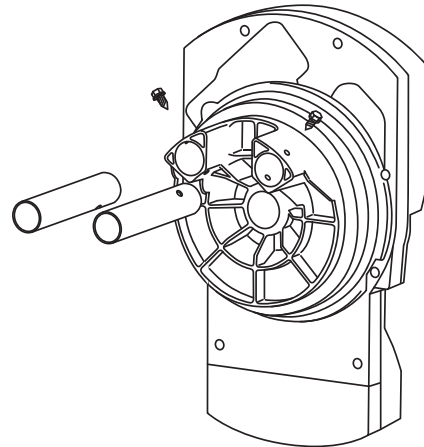

Place the Opener in Manual Release mode.

- Pull the release cord down and across to engage the ball into the cup.

The drive forks should now be able to be moved manually.

NOTE: To re-engage the opener, pull the release cord across and up.

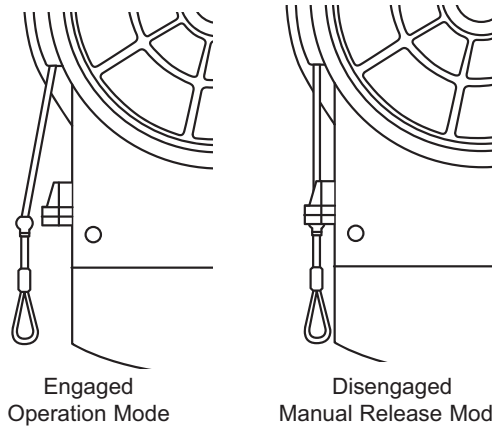

8 Installation steps

FOR RIGHT HAND INSTALLATIONS (REFER SECTION 7, page 5)

- Ensure that the opener position jumper (**wire connector**) is **installed** (refer Section 7, page 5).
- Place the opener in manual release mode (refer Section 7, page 5).

⚠ • Open the roller door fully. For safety, tie a rope around the door. **Ensure that the U-bolt on the left hand side of the door is secure.**

- Mark the position of the door shaft on the right hand door bracket.
- Carefully remove the U-bolt on the right hand side, checking that the spring tension inside the roller door is not being released.
- **You will need assistance for the following steps.** Slide or lift the door shaft clear of the door bracket supporting the door weight with a ladder or similar device. Then slip the opener over the shaft.
- The forks should engage either side of the support spoke.
- Typical installation: Place the door shaft back onto the door bracket in the position that it was originally. Clamp the opener to the door shaft with the supplied bracket plate, 8mm bolts and nuts. Tighten sufficiently to fasten the opener firmly to the shaft i.e. 25Nm- 28Nm. Replace U-bolt and secure firmly.

Minimum side room installation: Place the opener and door shaft onto the door bracket in the position that the door shaft was originally. Clamp the opener to the door shaft through the door bracket with the supplied bracket plate, 8mm bolts and nuts. Tighten sufficiently to fasten the opener firmly to the shaft i.e. 25Nm-28Nm.

- Remove any ropes used.

FOR LEFT HAND INSTALLATIONS (REFER SECTION 7, page 5)

- Ensure that the opener position jumper (**wire connector**) is **removed** (refer Section 7, page 5).
- Place the opener in manual release mode (refer Section 7, page 5).
- Open the roller door fully. For safety, tie a rope around the door.

⚠ **Ensure that the U-bolt on the right hand side of the door is secure.**

- Mark the position of the door shaft on the left hand door bracket.
- Carefully remove the U-bolt on the left hand side, checking that the spring tension inside the roller door is not being released.
- **You will need assistance for the following steps.** Slide or lift the door shaft clear of the door bracket supporting the door weight with a ladder or similar device. Then slip the opener over the shaft.
- The forks should engage either side of the support spoke.
- Typical installation: Place the door shaft back onto the door bracket in the position that it was originally. Clamp the opener to the door shaft with the supplied bracket plate, 8mm bolts and nuts. Tighten sufficiently to fasten the opener firmly to the shaft i.e. 25Nm- 28Nm. Replace U-bolt and secure firmly.

Minimum side room installation: Place the opener and door shaft onto the door bracket in the position that the door shaft was originally. Clamp the opener to the door shaft through the door bracket with the supplied bracket plate, 8mm bolts and nuts. Tighten sufficiently to fasten the opener firmly to the shaft i.e. 25Nm-28Nm.

- Remove any ropes used.

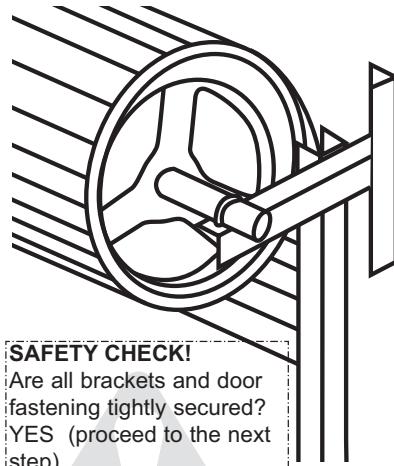

SAFETY CHECK!

Are all brackets and door fastening tightly secured?
YES (proceed to the next step)

NO (Tighten any loose fasteners before proceeding).

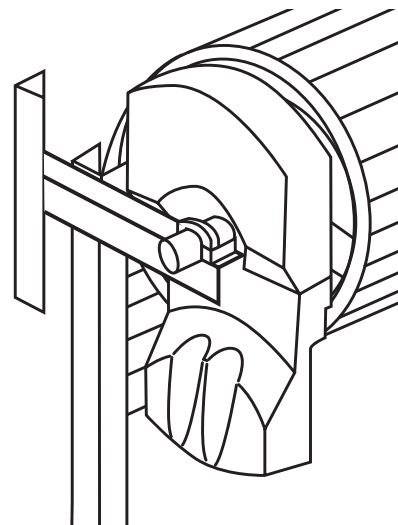
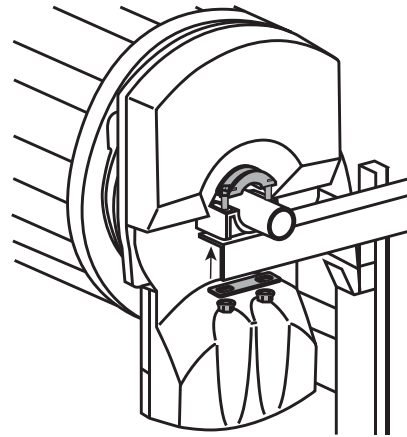

9 Attach the Release Handle and Cord

- Thread one end of the rope through the hole in the top of the red handle so "NOTICE" reads right side up as shown.
Secure with an overhand knot at least 25mm from the end of the rope to prevent slipping.
- Thread the other end of the rope through the loop of the manual release cable.
- Adjust rope length so the handle is no higher than 1.8m above the floor. Secure with an overhand knot. If the door is greater than 2.5m in height the Release Cord Extension kit accessory is required.

NOTE: If it is necessary to cut the rope, heat seal the cut end with a match or lighter to prevent unraveling.

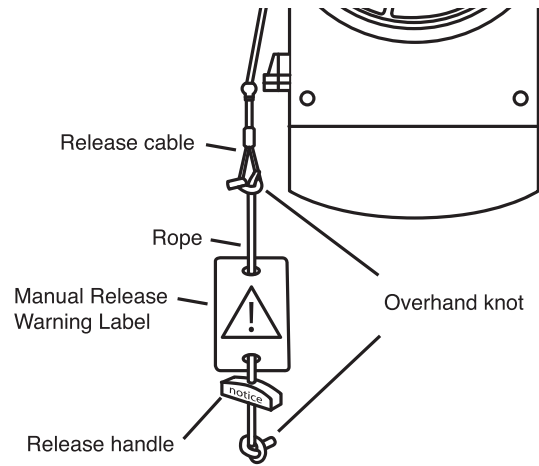

10 Operating the Manual Release



Take care when operating the manual release as an open door may fall rapidly due to weak or broken springs, or being out of balance.

To disengage the opener

Pull the release cord down and across to engage the ball into the cup.

The door should now be able to be moved manually.

To re-engage the opener

Pull the release cord across and up.

The door can now be operated by the opener.

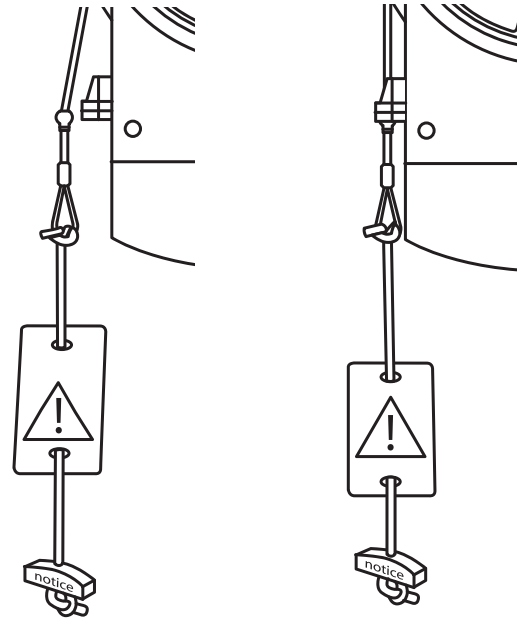

Engaged Operation Mode

Disengaged Manual Release Mode

11 Pinning the Door

Use two metal self tapping metal screws provided to hold the curtain to the door drum.

Note: A ballooning may delay the safety response and can compromise your garage door security.

- Pull the release cord down Firmly to disengage the motor. Once the door is closed pull the cord down firmly to re-engage the opener.
- Try to manually open the door with the opener engaged. Any excess door curtain may balloon out from the top of the drum.
- To remedy any ballooning use a cordless drill or socket to drive the self tapping metal screws provided 75mm up from where the curtain leaves the roll. Secure these through the curtain into the drum wheel at each end of the curtain.

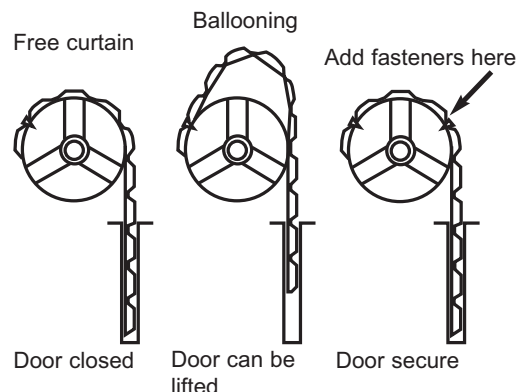

12 Setting the Limits

The Travel Limits regulate the points at which the door will stop when moving UP or DOWN. During the SetUp procedure, the motor will run and operate the door. The Opener must be fully installed on the door and all installation steps completed before proceeding.



Make sure the door is clear of obstruction. Ensure your hands are away from any moving parts before activating the door.

Position the door about half way and Engage the motor. (Section 10 page 7).

Remove the Lens cover from the Opener.

Connect the Opener to a 240VAC Power Point and Turn On.

SET TOP LIMIT

- Press and Hold the **Black** Limit button until the orange indicator Led starts flashing slowly, and then release. (Courtesy LEDs will go to low illumination).
- Press and Hold the **Black** Limit button, until the door reaches the desired open position. If set too high, adjust down using the **Purple** Learn button. (Make sure there is enough room for your vehicle to pass under).

SET BOTTOM LIMIT

- Press and Release the **Green** Start button, this sets the UP limit and begins **closing** the door, once the opener starts to move down, **IMMEDIATELY** Press and Hold the **Purple** Learn button until the door reaches the desired closed position, then release button or momentary press to inch further.

SAVE AND TEST

- Press and Release the **Green** Start button, this sets the DOWN position and begins **opening** the door to the fully open position.
- Close and Open the door 3 or 4 times using the **Green** Start button to confirm the limit settings. Courtesy LEDs should now be fully illuminated. Repeat the above procedure if necessary.



The Force Must now be set in order to complete your installation, see step 13.

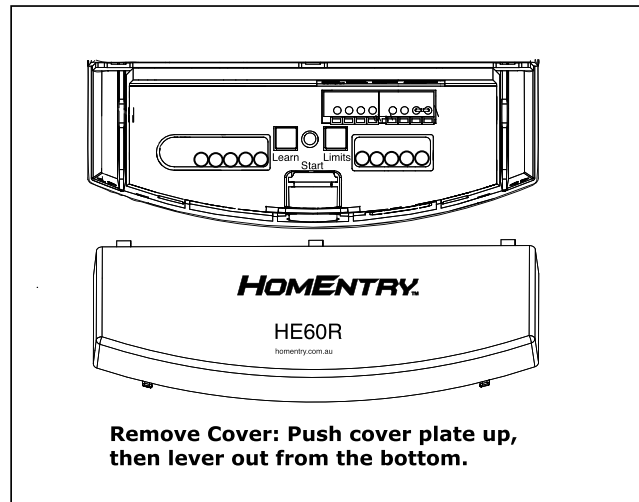

Remove Cover: Push cover plate up, then lever out from the bottom.

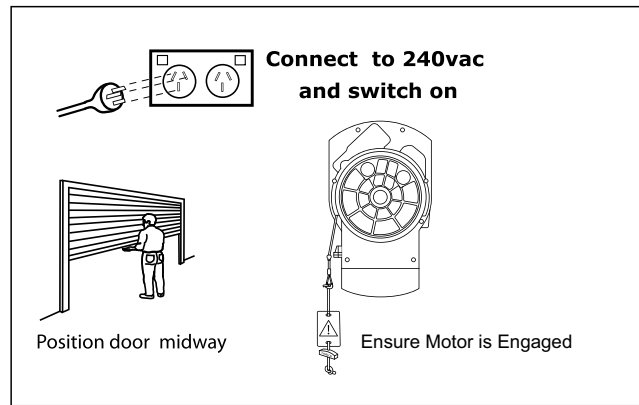

Connect to 240vac and switch on

Position door midway

Ensure Motor is Engaged

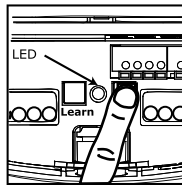

Limits (Black)

SET TOP LIMIT

Press and Hold Black

Flashing Orange LED
Courtesy LED dim

Limits (Black)

Use the Black button door UP (use purple down to adjust if required)

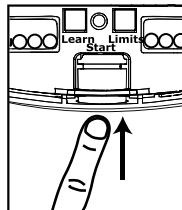

Green Start

SET BOTTOM LIMIT

Press Start located on the bottom of motor.

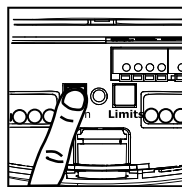

Learn (Purple)

Once door starts to move **(immediately)** Press and hold the Purple (Learn) Button (Down), release when door is fully closed. (Use the Black limit UP button to adjust if necessary)

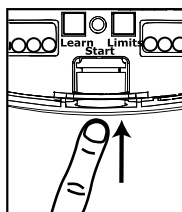

Green Start

SAVE AND TEST

Press the Green Start button to open the door and save the Limits.

Green Start

Press the Green Start button to close the door and complete test.

Orange LED will go out and courtesy LEDs will light up brightly

13 Setting the Force

The force, as measured on the closing edge of the door, should not exceed 400N (40kg). If the closing force is measured to more than 400N, the Protector System must be installed. See Section 16.

The force setting regulates the amount of power required to open and close the door.

- **Door should be closed.**
- Press the **PURPLE** button twice to enter opener into Force Adjustment Mode. The indicator LED will flash quickly (The Courtesy LEDs dim).
- Press the **Green** start button on the bottom of the opener. The door will travel to the UP limit. Press the Green start button again, the door will travel to the DOWN limit. The indicator LED will stop flashing when the force has been learned.
- The door must travel through a complete cycle, UP and DOWN, in order for the force to be set properly. If the opener cannot open and close your door fully, examine your door to ensure that it is balanced properly and is not sticking or binding.

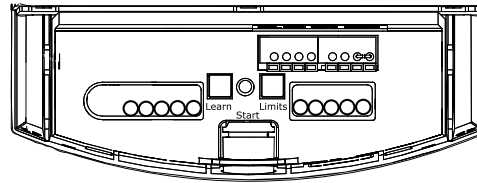

NB: Door must be in closed position

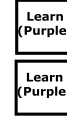
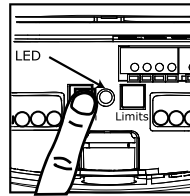

SETTING THE FORCE

Press the Purple Learn button twice



FAST Flashing Orange LED Courtesy LED dim

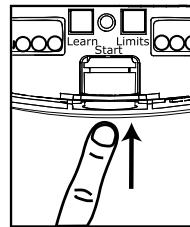

Press the Green Start button to open the door. Wait until door is fully open



Press the Green Start button to close the door save and set the door force.

- Orange LED will go out and Courtesy LEDs bright.

14 Testing the Safety Reverse System

The safety reverse system test is important.

The garage door must reverse on contact with a 40mm obstacle laid flat on the floor. Failure to properly adjust the opener may result in serious personal injury from a closing garage door. Operate the door in the down direction. The door must reverse on the obstruction. If the door stops on the obstruction, remove obstruction and repeat limit and force setting, Sections 12 & 13, pages 8 & 9. **Repeat test.**

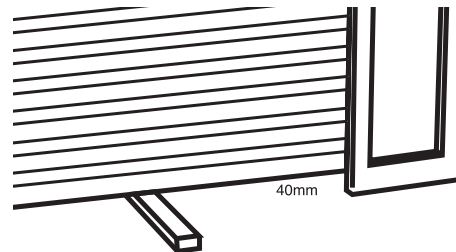

This test should be repeated monthly to ensure the safe operation of your opener.

15 Fixing Warning Labels

Once you have completed your installation and successfully carried out the Safety Reverse System Test outlined above. Install the warning labels provided with your motor.

Ensure the risk of Entrapment label is installed Adjacent to the release handle at height of less than 1800mm.

The WARNING label should be installed in a prominent place near any fixed control. Any fixed wall control or wireless door control should be mounted at a height of no less than 1500mm **out of the reach of children.**

Ensure the the instruction card concerning manual release of the door is attached to the rope as detailed in Section 9 page 7.

Read the safety instructions (page 1) for further details concerning safety.

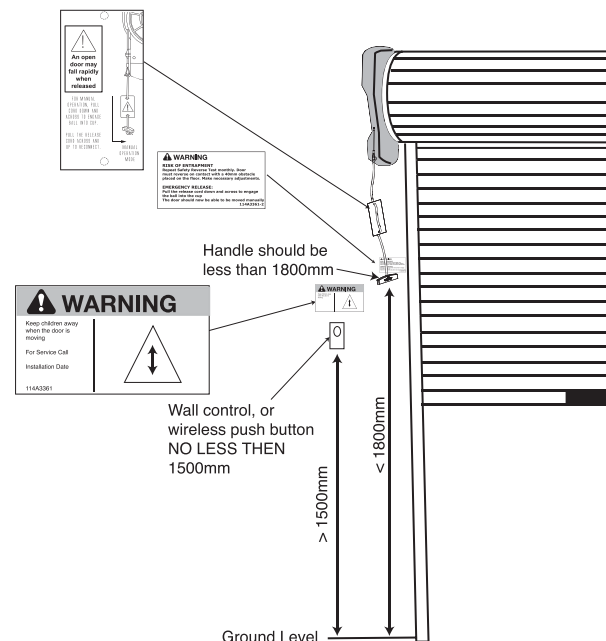

16 Install the Protector System™ (Safety Beams)

Install this accessory for all installations where the closing force as measured on the bottom of the door is over 400N (40kgf).

After opener has been installed and adjusted, The Protector System™ accessory can be installed. Instructions are included with this accessory.

The Protector System™ provides an additional measure of safety against a small child being caught under a garage door. It uses an infra-red beam which, when broken by an obstruction, causes a closing door to open and prevents an open door from closing and is **strongly recommended for homeowners with young children.**

Note: The opener will automatically detect the protector system when it is installed.

The Beams must be properly aligned or the door will not close.

The Protector System can not be removed after it has been installed and unobstructed for 5 minutes. Removing the beams after this time will not allow the door to close.

SAFETY FIRST!

Whilst Chamberlain have engineered safety features into your garage door opener, we urge you to consider fitting Safety Beams to your new garage door opener. In many countries these devices are compulsory to prevent serious injury or property damage. For your own peace of mind and the safety of others we recommend you install this inexpensive safety device.

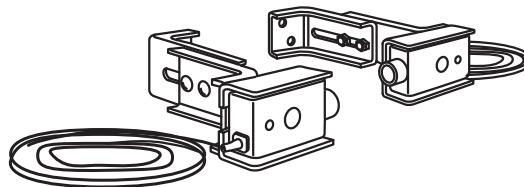

Complete instructions supplied with product.

17 Program your Opener & Remote

Please note your remote control (s) have already been programmed into your operator.

Activate the opener only when door is in full view, free of obstruction and properly adjusted. No one should enter or leave garage whilst door is in motion. Do not allow children to operate push button(s) or remote(s). Do not allow children to play near the door.

ADDING remotes using the "LEARN" Button

- Press and release the **PURPLE** "learn" button on the opener. The orange indicator light will glow steadily for 30 seconds.
- Within 30 seconds, press the button on your remote control or (optional) wireless wall control.
- Release the button when the opener light blinks. It has learned the code.

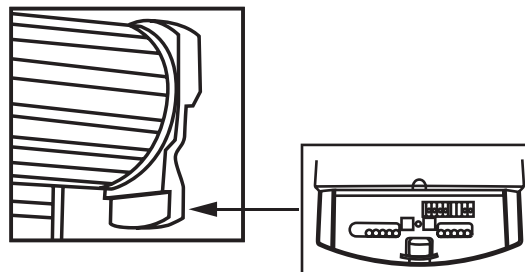

Delete ALL Remote Control Codes

(Please note this deletes all remotes and codes).

Press and hold the **PURPLE** learn button until the orange indicator light goes out (approximately 9 sec).



18 Special Features

- Multi function Control Panel
Connect white/red wire to the red quick connect terminal and the white wire to the white quick connect terminal.
- The Protector System™ (Safety Beams)
Connect both white wires to the white quick connect terminal and both white/black wires to the grey quick connect terminal.

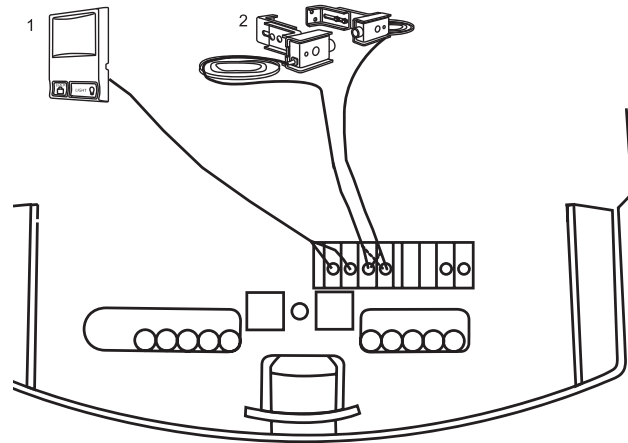

19 Motorlift/ HomEntry Compatible Accessories

1. Model 84330AML Single-Function Remote Control
2. Model 83335AML 3-Function Mini remote control
3. Model 84333AML 3-Function Remote Control
4. Model 8747AML Keyless Entry System

5. Model 770AML The Protector System
6. Model 845AML Control Panel
7. Model 75AML Illuminated Button
8. Model 760AML Outdoor Keyswitch
9. Model 1702AML Keyed Outdoor Emergency Release

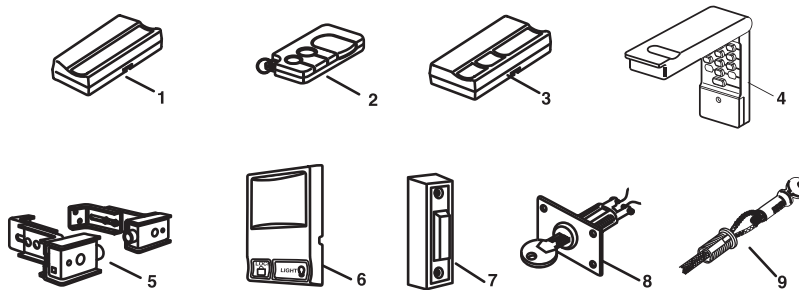

CARE OF YOUR OPENER

When properly installed, your opener will provide high performance with minimal maintenance. The opener does not require additional lubrication. Limit and Force Settings: These settings must be checked and properly set when the opener is installed. Weather conditions may cause some minor changes in the door operation, requiring some re-adjustments, particularly during the first year of operation. Refer to limit and force setting in Sections 12 & 13, page 8 & 9. **Follow the instructions carefully and repeat the safety reverse test after any adjustment.**

Remote Control: Additional remotes can be purchased at any time. Refer to Accessories. Any new remotes must be programmed into the opener. Remote Control Battery: The lithium batteries depending on use and local conditions will last for up to 5 years. If transmission range decreases, replace the battery .

Troubleshooting

1. The opener doesn't operate from either the GREEN start button or the remote controls:

- Does the opener have electric power? Plug a lamp into the outlet. If it doesn't light, check the fuse box.
- Have you disabled all door locks? Review installation instruction warnings on page 1.
- Is there a build-up of ice or snow under the door? The door may be frozen to the ground. Remove any restriction.
- The garage door spring may be broken. Have it replaced.

2. Opener operates from the remote control, but not from the wired wall control (optional accessory):

- Is the wall control lit? If not, reverse the two wires. If the opener runs, check for a faulty wire connection at the wall control, a short under the staples, or a broken wire.
- Are the wiring connections correct? Refer to wired wall control instructions.

3. The door operates from the GREEN start button or wired wall control, but not from the wireless wall control or remote control:

- If the wired wall control is installed and it is flashing, ensure the Lock feature is off.
- Program the opener to match the remote control code. (Refer to Section 17, page 10.) Repeat with all remotes.

4. The remote control has short range:

- Change the location of the remote control in your car.
- Check to be sure the antenna on the bottom of the opener extends fully downward.
- Some installations may have shorter range due to a metal door, foil backed insulation, or metal garage siding.

5. The garage door opens and closes by itself:

- Be sure that all remote control push buttons are off.
- If the wired wall control (optional accessory) is installed, remove the bell wire from the wired wall control terminals and operate from the GREEN start button or remote control. If this solves the problem, the wired wall control is faulty (replace), or there is an intermittent short on the wire between the wired wall control and the opener.
- Clear memory and re-program all wireless wall controls and remote controls.

6. The door reverses and stops before opening completely:

- Is something obstructing the door? Is it out of balance, or are the springs broken? Remove the obstruction or repair the door.
- Repeat the limit and force setting in Section 12 & 13, pages 8 & 9 . Repeat safety reverse test after adjustments (Section 14 page 9).

7. The door reverses for no apparent reason and opener lights blink for 5 seconds after reversing:

- Check the Protector System (safety beams), if installed. Correct alignment if the red light on the beam is solid.

8. The door opens but won't close or reverses while closing:

- Is something obstructing the door? Pull the manual release handle. Operate the door manually. If it is unbalanced or binding, call a trained door systems

- Repeat the limit and force setting in Section 12 & 13, pages 8 & 9 . Repeat safety reverse test after adjustments (Section 14 page 9).

- If The Protector System is installed check the beams, both Red LEDs should be on.

9. The opener strains to operate door:

- The door may be out of balance or the springs may be broken. Close the door and use the manual release to disconnect the door. Open and close the door manually. A properly balanced door will stay in any point of travel while being supported entirely by its springs. If it does not, disconnect the opener and call a trained door systems technician.

10. The opener motor hums briefly, then won't work:

- Check that the door is not in manual release mode, refer Section 10, page 7.
- The garage door springs may be broken. See above.
- If the problem occurs on the first operation of the opener, door may be locked. Disable any door locks.

11. The opener won't operate due to power failure:

- Use the manual release handle to disconnect the door. The door can be opened and closed manually. When power is restored, re-engage the opener, refer Section 10, page 7.

12. Setting the limits manually:

- a. Check that the opener position jumper is correct, refer Section 7, page 5.

- b. Press and hold the **BLACK** button until the orange indicator light starts flashing slowly then release.

- c. Press the **BLACK** button to move the door UP or the **PURPLE** button to move the door DOWN until the door reaches the desired UP limit. Ensuring there is enough clearance for your vehicle.

- d. Press the **GREEN** start button. This sets the UP limit and begins closing the door. Immediately press either the **PURPLE** or the **BLACK** button. The door will stop. Adjust the desired DOWN limit using the **BLACK** and the **PURPLE** buttons. Check to be sure the door is fully closed without applying excessive pressure to the door curtain. Press the **GREEN** start button. This sets the DOWN limit and begins opening the door. NOTE: If neither the **BLACK** or the **PURPLE** button is pressed, the door will reverse off the floor and the DOWN travel limit will be set automatically.

- e. Open and close the door with the **GREEN** start button, remote control or wall control 2 or 3 times.

- If the door does not stop in the desired UP limit or reverses before the door stops at the DOWN limit. Proceed to Setting the Force, Section 13, page 9. If the door still does not stop at the desired limits is something obstructing the door? Disengage the opener. Open and close the door manually. If it is unbalanced or binding, call a trained door systems technician.

- If the door stops at both the desired UP and DOWN limits, proceed to Setting the Force.

MAINTENANCE OF YOUR OPENER

Once a Month:

- Repeat safety reverse test.
Make any necessary adjustments (see pages 8 & 9).
- Manually operate door. If it is unbalanced or binding, call for professional garage door service.
- Check to be sure door opens and closes fully.
Set Limits and/or Force if necessary.

OPERATION OF YOUR OPENER

Your opener can be activated by any of the following devices:

- **The green start button**
Hold the button down until door starts to move.
- **The Wall Control, Outside Keylock or Keyless Entry System** (if you have installed any of these accessories).
- **The Remote Control Transmitter or Wireless Wall Control (84330AML)**
Hold the push button down until the door starts to move.

When the Opener is activated by Remote Control, Green Start Button or Wall Control:

- If open, the door will close. If closed, the door will open.
- If closing, the door will stop.
- If opening, the door will stop (allowing space for entry and exit of pets and for fresh air).
- If the door has been stopped in a partially open or closed position, it will reverse direction.
- If an obstruction is encountered while closing, the door will reverse.
- If an obstruction is encountered while opening, the door will reverse and stop.
- The optional Protector System™ uses an invisible beam which, when broken by an obstruction, causes a closing door to open and prevents an open door from closing. It is **STRONGLY RECOMMENDED** for homeowners with young children.

Allow a 15 minute cooling period after 4 minutes of continuous operation of the opener.

Opening the Door Manually:

Door should be fully closed if possible. Weak or broken springs could allow an open door to fall rapidly. Property damage or serious personal injury could result.

The door can be opened manually by pulling the release cord down and across to engage the ball into the cup. To re-connect the door, pull the release cord across and up to engage the opener .

The Opener Light Will Turn On:

- when opener is initially plugged in;
- when the power is briefly interrupted;
- when the opener is activated.
- The light turns off automatically after 2-1/2 minutes.

SPECIFICATIONS HE60R

Input Voltage:	230-240VAC, 50Hz, 85W
Rated Load:	15Nm
Max.Pull Force:	450N
Max. Door Weight	60kg
Idle Current:	less than 25mA @ 230VAC
Drive:	DC gearmotor permanent lubrication
Max. Drum Rotations:	5
Memory Registers:	64
Operating Frequency:	433.92MHz

SPECIAL NOTE: Chamberlain strongly recommends that the protector system be installed on all garage door openers.

CHAMBERLAIN LIMITED WARRANTY

HomEntry HE60R
Roller Door Operator

Chamberlain Australia Pty Limited / Chamberlain New Zealand Limited (Seller) warrants to the original purchaser of the Chamberlain HE60R Roller Door Operator (Unit) that it is free from defects in material and/or workmanship for a period of 2 YEARS from the date of first purchase from the Seller

Please retain your proof-of-purchase in the unlikely event you require warranty service.

If, during the limited warranty period, the Unit fails due to defects in materials or workmanship Chamberlain will, provided the defective part or Unit is returned freight and insurance prepaid and well packaged to the nearest Chamberlain office or authorised installer, undertake to repair or, at its option, replace any defective part or Unit and return it to the Buyer at no cost. Repairs and replacement parts are warranted for the remaining portion of the original warranty period.

Limited warranty on motor

Chamberlain will furnish a replacement motor free of charge, if it is found to be defective. Labour costs may apply.

Where the Unit has been installed by an authorised installer, Chamberlain will furnish replacement parts free of charge through the authorised installer. A service fee for on-site service may apply. In-warranty service

During the warranty period, if the product appears as though it may be defective, call our toll free service before removal of the unit. A Chamberlain technician will diagnose the problem and promptly supply you with the parts for "do-it-yourself" repairs, or provide you with shipping instructions for a factory repair or replacement. If an authorised installer installed your unit you must call them for prompt on-site service.

If our service centre determines that a warranty claim has been made in respect of a failure or defect arising under out of any exclusion set out below, we may charge you a fee to repair and/or return the Unit to you.

Exclusions

This warranty does not cover any failure of the Unit due to:

1. non-compliance with the instructions regarding installation, operation, maintenance and testing of the Unit or of any product with which the Unit is used.
2. any attempt to repair, dismantle, reinstall or move the Product to another location once the Product is installed by any person other than an authorised installer.
3. tampering, neglect, abuse, wear and tear, accident, electrical storm, excessive use or conditions other than normal domestic use.

This warranty does not cover any problems with, or relating to, the garage door or garage door hardware, including but not limited to the door springs, door rollers, door alignment or hinges, any problems caused by electrical faults, replacement of batteries or light bulbs or labour charges for reinstalling a repaired or replaced Units.

Liability – Australia only

Under no circumstances shall the Seller be liable for consequential, incidental or special damages arising in connection with the use, or inability to use, the Unit. In no event shall the Seller's liability for damages or injury arising from breach of law or contract or for negligence, exceed the cost of repairing or replacing the Unit or refunding the purchase price of the Unit.

Under Division 2 Part V of the Trade Practices Act, 1974, certain warranties and conditions (Implied Terms) are implied into contracts for the supply of goods or services if the goods or services are of a kind ordinarily acquired for personal, domestic or household use or consumption. Liability for breach of those Implied Terms cannot be excluded or limited and the limitations and exclusions above do not apply to the Implied Terms.

Except for the Implied Terms and the warranties set out above, the Seller excludes all warranties and conditions implied by statute, at law, in fact or otherwise.

Liability – New Zealand only

Except as set out in the Fair Trading Act 1986 and the Consumer Guarantees Act 1993:

(a) all other guarantees, warranties and representations in relation to the Unit or its supply are excluded to the extent that the Seller can lawfully exclude them; and

(b) under no circumstances shall the Seller be liable for consequential, incidental or special damages arising in connection with the use, or inability to use, the Unit, other than those which were reasonably foreseeable as liable to result from the failure.

NOTE: We request that you attach your sales docket or invoice to this manual to enable you to establish the date of purchase in the unlikely event of a service call being made. Chamberlain reserves the right to change the design and specification without prior notification. Some features or accessories may not be available in certain markets or areas. Please check with your distributor.

Chamberlain service centres:

Australia

Phone toll free 1800 638 234

Fax toll free 1800 888 121

New Zealand

Auckland phone 09 415 4393

Phone toll free 0800 637 546

Fax toll free 0800 653 663

www.homentry.com.au