



HDP1 GATE OPENER INSTALLATION AND OWNERS MANUAL



We recommend a 12V Deep Cycle Marine Battery for solar installations, **Not Included**.
The Ghost Controls Battery Box Kit (ABBT2) is recommended for AC Transformer installations, **Not Included**.



Installation Video

LIMITED LIFETIME WARRANTY ON MOTOR AND GEAR ASSEMBLY!



WARNING: This product can expose you to chemicals including lead, which is known to the State of California to cause cancer. For more information, go to www.P65Warnings.ca.gov

02-2023 | HDP1IM
MADE IN CHINA
©Ghost Controls® 2023

CONTACT US:

3166 Hartsfield Road, Tallahassee, FL 32303

www.ghostcontrols.com

For sales and product information:

ghostcontrols.com/pages/contact-us or

Call: 850-558-5520

For a dealer near you:

ghostcontrols.com/pages/dealer-locator

For installation assistance and technical support:

ghostcontrols.com/pages/technical-support

Call: 850-898-1411

Schedule a technical support call that fits your time schedule:

ghostcontrols.com/pages/schedule-a-call

Things to have with you when we call:

Small screwdriver, working remote control and voltmeter (if available)

Product information, technical article, and installation videos can be found at:

ghostcontrols.com/pages/technical-support or
ghostcontrols.com/pages/installation-video

CONTENTS

Installation and Owners Manual



Warranty Registration	page 5
Operator Specifications	page 6
System Safety	page 7
System Overview	page 11
Installation Planning	page 13
Tools Needed	page 17
Included Parts	page 18
PULL-TO-OPEN INSTALLATION	page 21
Control Box and Battery Box Installation	page 26
Connecting Battery and Battery Harness	page 27
Connecting Arm to Control Box	page 28
Setup System Controller	page 29
Front Mount Gate Bracket Installation	page 32
Programming the Closed Limit	page 36
Wiring and Connecting the AC Transformer	page 37
Connecting the System with Solar	page 38
Setting the Auto Close Feature	page 39
PUSH-TO-OPEN INSTALLATION	page 41
Control Box and Battery Installation	page 46
Connecting Battery and Battery Harness	page 47
Connecting Arm to Control Box	page 48
Setup System Controller	page 49
Front Mount Gate Bracket Installation	page 52
Programming the Open Limit	page 56
Wiring and Connecting the AC Transformer	page 57
Connecting the System with Solar	page 58
Setting the Auto Close Feature	page 59
Troubleshooting	page 61
Connecting Optional Accessories	page 63
Manual Gate Operation	page 65
Accessories	page 66

BEFORE YOU BEGIN:

- If you would like to access your gate using bluetooth or wifi you will need to purchase the Ghost Multi Connect™ Kit (AXMC) for your system, sold separately and download the free app.
- Push-To-Open applications (gate that swings away from the property) will require the Ghost Controls push-to-open bracket kit (AXPO).
- If charging your system with the AC transformer, you will need to purchase a 16 gauge stranded, 2-conductor low voltage wire (not included) to connect the transformer to the gate operator control board. Up to 1,000 ft. of wire can be used.
- A 12V Battery is required to operate your gate opener. The Ghost Controls ABBT2 Battery Box with two 12V Batteries is a good option if using the AC Transformer to recharge the systems battery.
- **FOR SOLAR INSTALLATIONS ON A SINGLE OR DUAL GATE USING THE GHOST MULTI CONNECT™ KIT WE RECOMMEND A 12V DEEP CYCLE MARINE BATTERY.**
- *Make sure to choose the correct solar power for the area you live in, gate location, number of accessories added and the number of uses (opening and closing the gate) every day. For optimal performance more solar power is better for recharging the gate batteries.
- The Wired (AXXV) and Wireless Vehicle Sensors (AXWV) are not recommended or intended for use with properties that contain livestock or other animals. Instead, we recommend using the Wireless Keypad (AXWK).

CUSTOMIZING YOUR GATE:

Information on additional accessories shown below can be found on the accessory page <?> or visit www.ghostcontrols.com

The build a system below shows a dual gate system and what accessories you can all add to either a single or dual gate entrance.

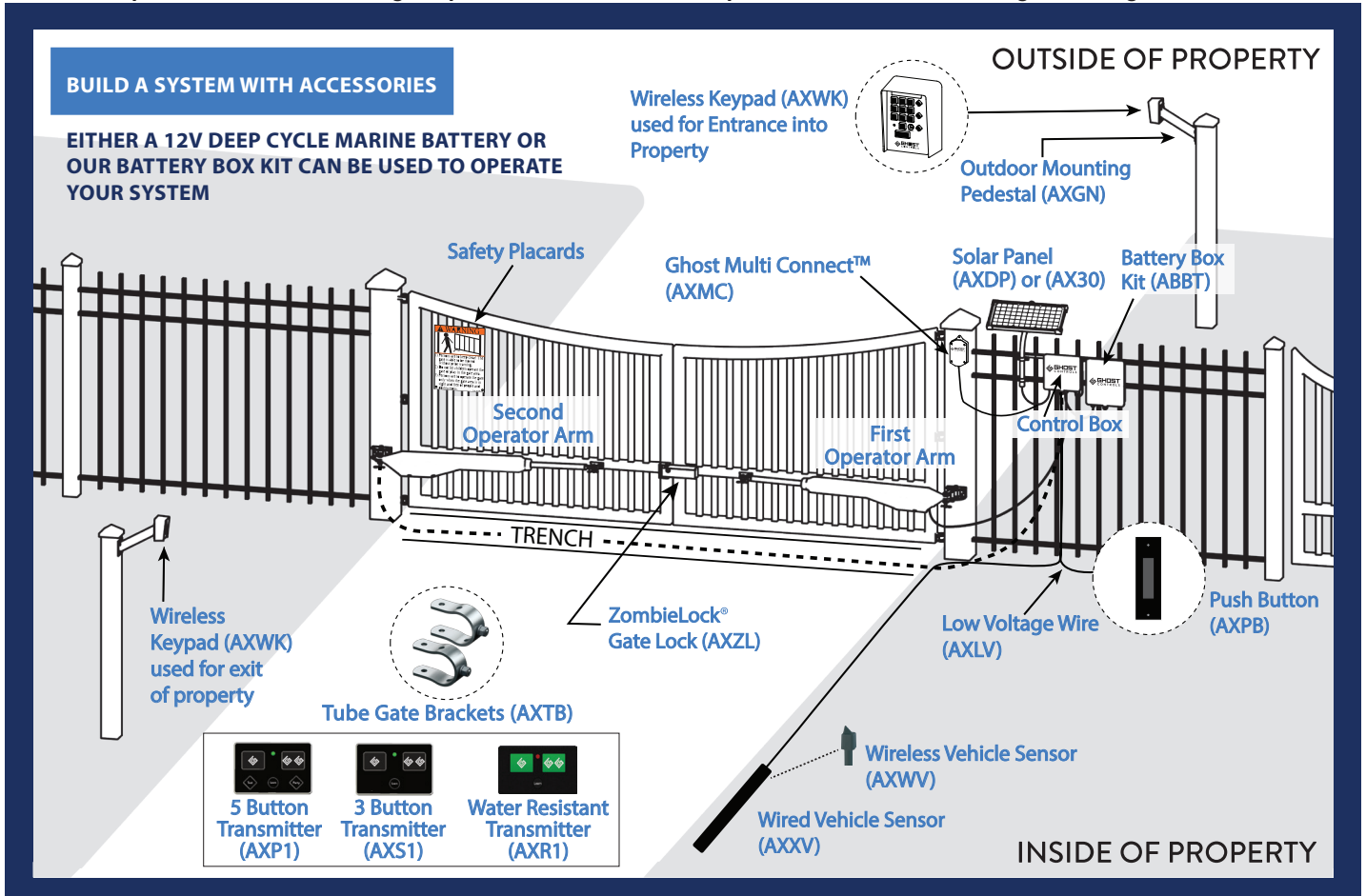

*Your Ghost Opener Arm might look different than illustrations throughout this manual

PROTECT YOUR INVESTMENT!

WARRANTY

REGISTER ONLINE WWW.GHOSTCONTROLS.COM

NOTE
If your unable to access the internet please fill out the warranty form below and mail in to us at Ghost Controls
3166 Hartsfield Road, Tallahassee, FL 32303

First Name: _____ Last Name: _____
Street: _____ Apt. #: _____
City: _____ State: _____ Zip: _____
Phone Number: _____ Email Address: _____

Items Purchased:

- HDP1
- HDP2

Where did you buy your gate opener system? (please include a copy of your receipt)

Type of gate you are using?

- Chainlink
- Ornamental
- Tube
- Vinyl

Approximate Gate Weight: _____ pounds per leaf

Approximate Gate Length: _____ feet per leaf

Type of Application:

- Farm
- Home
- Business

Item Serial Number: _____ Item Serial Number: _____ Manufacturer Date: _____

Did you purchase any accessories? (Please list below)

SPECIFICATIONS

HDP1 GATE OPERATOR KIT



SPECIFICATIONS

- Compliance: The operator is system certified to be in compliance with UL325 Standard, 7th Edition
- System Operating Voltage: 12V DC
- System Battery Type: 12V DC Deep Cycle Marine Battery Required (not included) or Battery Box Kit (ABBT2) (not included)
- System Current: 1-2 Amps is typical when active. Standby is 20 milliamps
- Operator Arm:
 - Maximum Stroke Distance: 26 Inches
 - Minimum Stroke Distance: 5.5 Inches
- Maximum Gate Length: 20 Feet
- Operator Opening Speed: 90 degrees in approximately 15 seconds
- Maximum Operator Opening Range: 110 degrees
- Linear Actuator Operating Temperature: -5°F to 160°F

Max	8'	10'	12'	14'	16'	18'	20'
1000 lbs.	H						
900 lbs.		H					
800 lbs.			H				
700 lbs.				H			
600 lbs.					H		
500 lbs.						H	
400 lbs.							H
350 lbs.							
325 lbs.							
300 lbs.	↓	↓	↓	↓	↓	↓	↓

Maximum Gate Length and Weight

SYSTEM SAFETY

GATE OPENER SYSTEMS

This manual contains important safety precautions and warnings for both the installer and end users or consumers of this automatic gate opener system. The following warnings and safety are intended to apply to the most common applications but may not apply to all possible installation and applications for these products. To reduce risk of injury or death:

- I. Carefully read and follow all safety precautions, warnings, installation and operating instructions.
- II. **DO NOT ALLOW CHILDREN TO OPERATE GATE CONTROLS.** Do not allow children or pets to play near the gate opener system. Keep all gate control accessories such as remote transmitters, keypads, and push buttons out of reach of children and store in a secure area when not in use.
- III. Understand how to disconnect the power and manually open the gate (beginning on page 63) **BEFORE** you begin using the gate opener system. If you are unsure of any of these steps, please contact GHOST CONTROLS® Technical Support at 850-898-1411 or online at ghostcontrols.com/pages/technical-support
- IV. Disconnect the gate operator from the gate only when the gate is not in motion and the opener system is turned off.
- V. Moving gates can be dangerous. No one, including people or animals, should cross the path of a moving gate. Maintain a safe distance from moving parts and avoid any areas where hands or fingers could be pinched.
- VI. Become familiar with potential entrapment zones as shown below and avoid these areas when the gate is turned on.
- VII. The gate opener system must be installed only in applications that it is specifically designed for including: frequency of use, length, and weight of the gate.
- VIII. Install the gate operator system on the inside of the property, gate, or fence line to prevent public access to it. Most applications are installed in a pull-to-open configuration so that the gate opens into the property and away from any public roads.
- IX. The control board for the gate operator system should be protected from unauthorized access inside the control box to prevent tampering or adjustments to its setting once installed. The control box is designed so that a padlock can be attached to keep the box securely closed. An accessory Clevis Pin (AXLC) is available for purchase to secure the rear mount of the operator(s) (only) to the post with a padlock.
- X. Keypads and push-buttons to activate the gate operator system must be a minimum of 10 feet away **IN DIRECT LINE OF SIGHT VISIBILITY TO THE GATE** so that the user can verify that any potential entrapment areas are clear of potential obstructions.
- XI. The included warning signs must be attached to each side of the gate to alert the public of the automatic gate operator system. Please contact GHOST CONTROLS® Technical Support for replacement signs if yours become damaged.
- XII. While the gate is moving do not drive into the gate area to prevent entrapment and potential damage to your vehicle, gate, AND the gate opener system.
- XIII. Do not attempt to “race the gate” by driving through the gate while it is opening or closing. This is extremely dangerous and can cause damage to your vehicle, gate, AND the gate opener system.
- XIV. Maintain the gate and the gate opener system to make sure that the gate continues to swing freely and is level throughout the entire swing path. The gate hinges should be lubricated regularly, the condition of the battery checked every few months, and all connections checked no less than an annual basis.
- XV. In the event that you sell the gate opener system or your property with a system installed, please provide these instructions to the new owners. The most recent version of these instructions can be found on our support website at ghostcontrols.com/pages/manuals

VEHICULAR GATE STANDARD

We recommend that all vehicular gates be constructed and installed in accordance with Active Standard ASTM F2200, Standard Specification for Automated Vehicular Gate Construction. For more information on this standard, contact ASTM directly at www.astm.org/Standards/F2200.htm

WARNING SIGNS

The included warning signs must be installed on both the inside and outside of the gate.

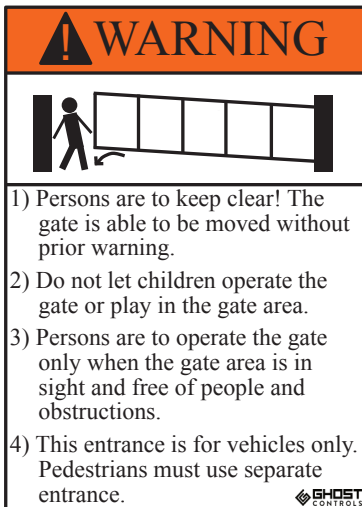

ALARM

Your GHOST CONTROLS® Gate Operator system includes an audible alarm. This alarm will continue to sound for 5 minutes when two sequential obstructions are detected during gate travel per UL325 safety standards or until one of the following occurs:

- The gate operator receives an intended signal from a hard wired entry/exit source such as a push button or a wired keypad. Note that wireless transmitters and wireless keypads cannot deactivate the alarm.
- The gate operator system is powered off and then on again at the main power switch in the control box.

NOTE

The alarm may also be used as audio feedback for other modes of operation under normal operation.

SWING GATE PROTECTION AND ENTRAPMENT ZONES

As specified in Gate Operator Safety Standard, UL325 (30A 1.1) 7th Edition, all gate operators must include two independent means of entrapment protection. All GHOST CONTROLS® Automatic Gate opener systems meet this standard as indicated on the product packaging through the following:

1. TYPE A Inherent.
2. Number one above AND either of the following two options:
 - A. TYPE C Inherent force limiting.
 - B. TYPE B1 and B2 monitored contact and non-contact sensors.

If you have questions about compatibility of third party safety devices, please contact GHOST CONTROLS® technical support for assistance at 850-898-1411 or online at ghostcontrols.com/pages/technical-support

If using monitored photo eyes refer to the instructions for proper placement of the sensors. Proper installation of these sensors is critical to avoid false tripping while gate is in motion and to reduce potential entrapment.

CAUTION

Extreme caution must be exercised when automatic gate opener system is in operation, regardless of which safety systems are installed and in use.

SINGLE

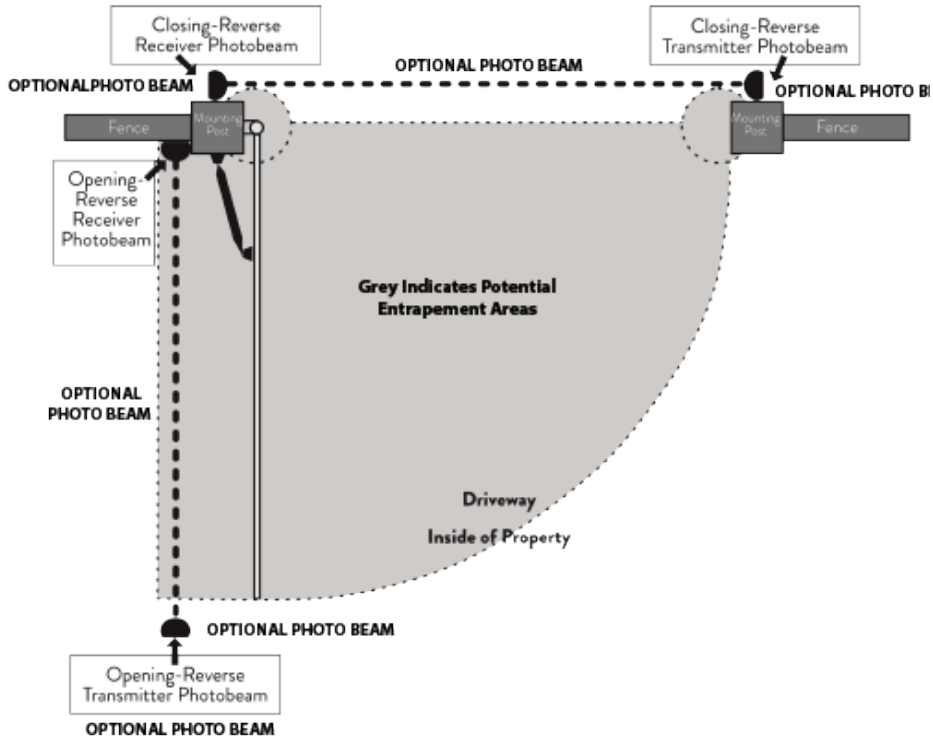

DUAL

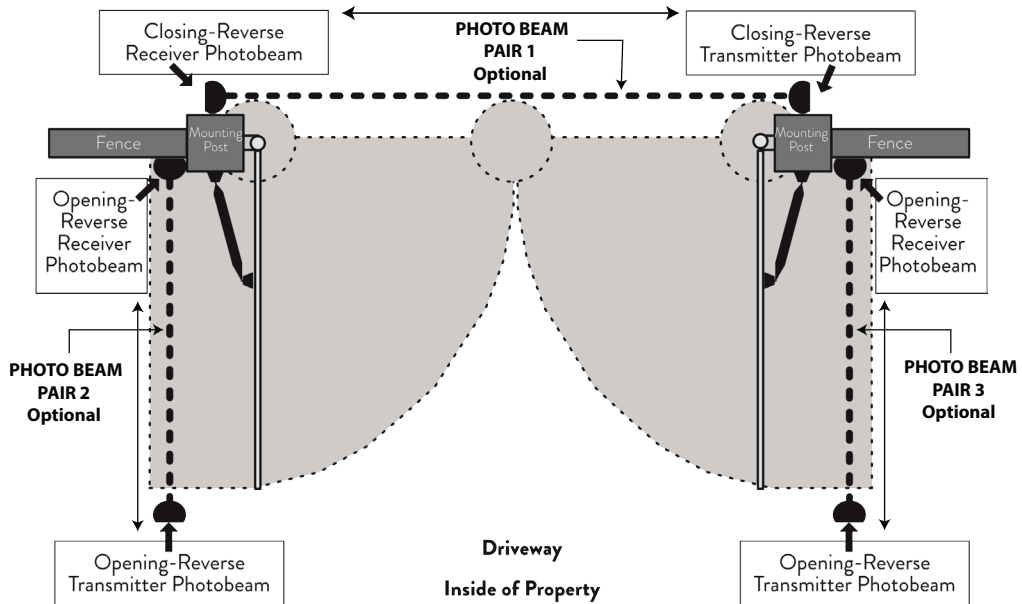

ENTRAPMENT AREA	NOTES
Between gate and post	Keep hands, feet, and pets away from this area when gate is in motion.
Pinch point between opener and gate	Keep hands, feet, and pets away from this area when gate is in motion.
Path of the moving gate	All one zone
Leading edge of gate and pinch point between gates in a dual gate installation	The leading edge of the gate in motion can easily cause injury to people, pets, or livestock, and will damage property including vehicles if it comes into contact with them.

SYSTEM OVERVIEW

IMPORTANT INSTRUCTIONS

Thank you for choosing a GHOST CONTROLS® Automatic Gate Opener system, the most innovative gate opener systems available for residential applications on the market today. This manual will guide you through the proper installation and maintenance methods. To reduce the risk of injury or death: **READ, UNDERSTAND, AND FOLLOW ALL INSTRUCTIONS CAREFULLY AND COMPLETELY.** Following these directions is critical to a successful and safe operating environment.

1. This gate operator is only intended for use on gates intended for vehicular access and is not intended for pedestrian gate applications. Pedestrians must use a separate entrance.
2. The GHOST CONTROLS® Automatic Gate Opener can be installed on a pull-to-open application with the items included in the kit. For push-to-open applications you will need to purchase the required Push-To-Open (item AXPO) bracket kit from your local retailer or visit ghostcontrols.com/shop or contact GHOST CONTROLS® Sales at 850-846-6400 to purchase.
3. This GHOST CONTROLS® Automatic Gate Opener features a patent-pending SafeForce® power limiting feature that doesn't require Photo Eyes for entrapment protection in most applications of a properly installed gate. During installation, you may instead choose to use external monitored safety devices such as non-contact photo eyes (sold separately) and will need to enable this setting on the main system controller during setup.
4. The operator can be used on a variety of gate types, but **CAN NOT BE USED ON SOLID OR WOOD PANEL GATES.** Solid panel gates have a higher resistance to wind and may result in damage to the automatic gate operator.
5. All GHOST CONTROLS® Automatic Gate Operators include automatic reversing safety features that will make the gates stop and reverse direction within 2 seconds of encountering an obstruction. There is a manual setting on the main gate operator control board labeled Force Setting that adjusts the sensitivity of this feature.
6. This GHOST CONTROLS® Automatic Gate Operator can be enhanced with additional GHOST CONTROLS® accessories such as our remote transmitters, keypads, and all other accessories, sold separately. (Accessories see page 66). The GHOST CONTROLS® technical support team is happy to assist in verifying compatibility of any products not offered by GHOST CONTROLS®. For additional assistance, please contact GHOST CONTROLS® Technical support ghostcontrols.com/pages/technical-support or by calling 850-898-1411.
7. Check all local building codes and ordinances prior to installing this automatic gate operator system to make sure your planned installation is in compliance.
8. Your gate must be in good working condition before installation of the automatic gate operator system and meet the following criteria:
 - A. **GATE CAN NOT USE WHEELS OR LAND GUY WIRES** for support or drag along the ground at any point in the opening or closing cycle.
 - B. **GATE SHOULD BE LEVEL, PLUMB, AND MOVE FREELY IN BOTH DIRECTIONS WHEN MINIMAL FORCE IS APPLIED IN THE OPENING OR CLOSING DIRECTION.**
 - C. Gate should NOT open uphill or downhill.
9. The vehicular entry gate system must be installed in a location that prevents entrapment by providing sufficient clearance between it and adjacent structures when opening and closing.
10. When planning a system that will allow entry from a busy road or highway, make sure the system is placed far enough from the road to prevent traffic congestion.

- 11. Swing gate systems must not open into public access areas or into the road which could cause collision with a moving vehicle.
- 12. Test the gate operator monthly. The gate MUST reverse on contact with a rigid object or stop when an object activates the non-contact sensors. After adjusting the force or the limit of travel, retest the gate operator. Failure to adjust and retest the gate operator properly can increase the risk of injury or death.
- 13. **SEPARATE PEDESTRIAN GATE IS REQUIRED!**
- 14. Single or dual gate operation based on the size of your opening, gate specifications, and operator system capacities.
 - A. Dual gate operations require trenching across the driveway so that the power cable for the secondary gate operator can be buried. (shown in diagram below)
 - B. The power cable should always be enclosed in PVC conduit for protection, including when buried across the driveway in dual gate applications.

- 15. Swing direction of gate(s). The image (shown in diagram below) indicates the more common “Pull-to-Open” installation and the less common “Push-to-Open” installation.

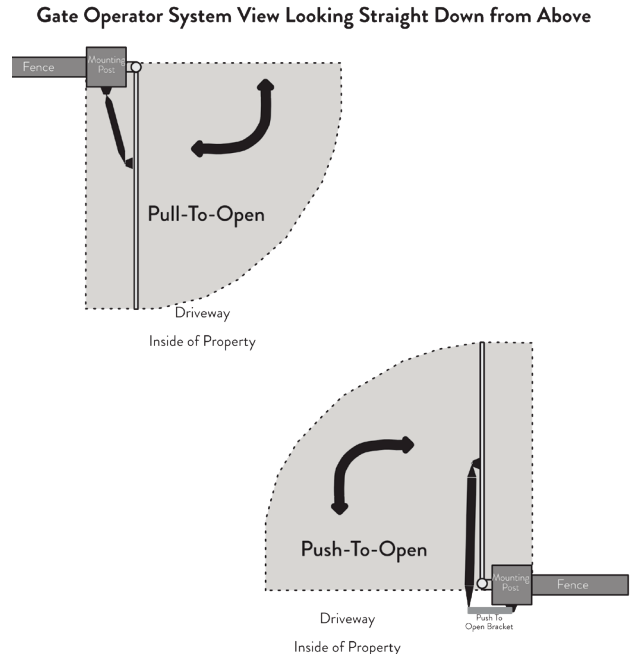

- 16. **Wired and Wireless Vehicle Sensors should NOT be used on properties that contain livestock or animals. Instead, we recommend using the Wireless Keypad (AXWK).**

17. SAVE THESE INSTRUCTIONS.

- 18. **ELECTRIC FENCES:** If an electric fence is installed at or near the automatic gate opener it can cause the unit to not function correctly.

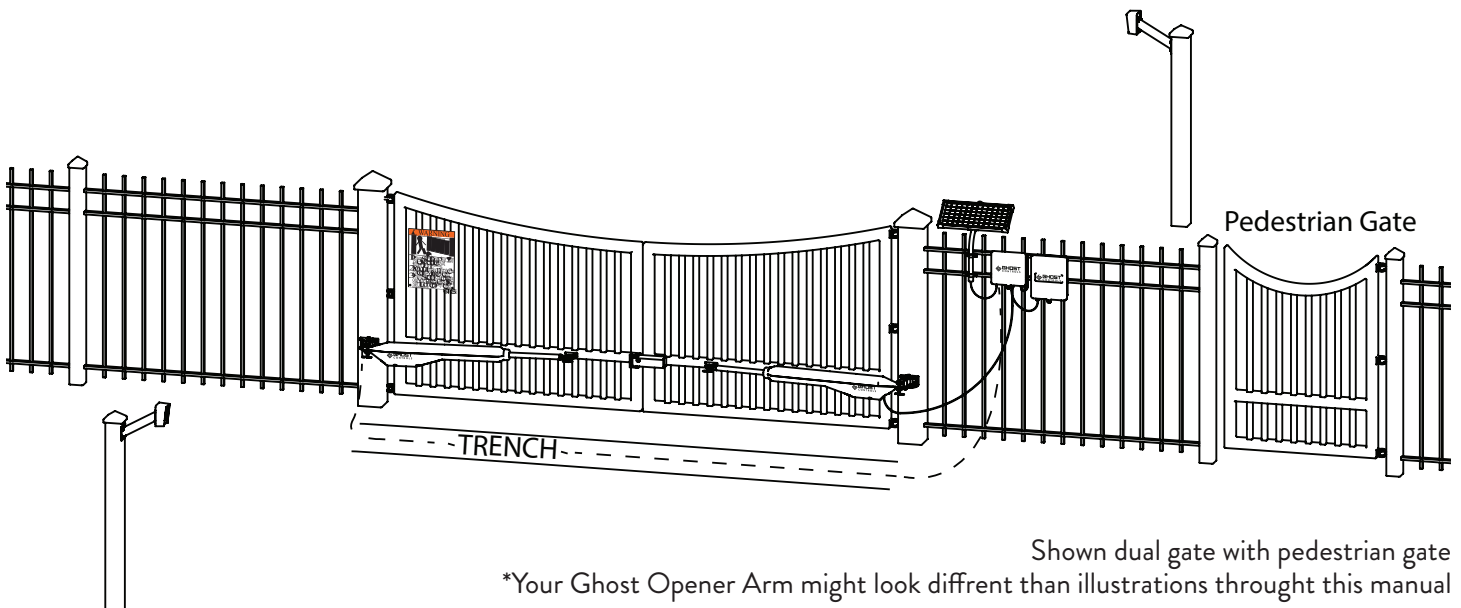

INSTALLATION PLANNING

SITE PLANNING

INSTALLATION VIDEO CAN BE FOUND AT ghostcontrols.com/pages/installation-video

PREPARE THE GATE

Proper installation, care, and ongoing maintenance of the gate is critical to increased usage life of the automatic gate operator system. The following items should be considered and addressed if needed PRIOR to installation of the automatic gate operator system:

1. The gate must swing freely throughout its entire range of motion (fully open to fully closed) remaining plumb and level. The gate should not swing uphill or downhill when opening or closing.
2. The gate must not drag on the ground at any point during its motion and **MUST NOT BE SUPPORTED BY ROLLERS OR WHEELS**. Guy wires should also not be used to support the gate.
3. Extremely heavy gates that exceed 200 lbs in weight per leaf should be **mounted with ball bearing hinges that include grease fittings**.
4. The gate should be mounted to a very stable post or column that is secured in the ground with concrete. Securing the post with concrete reduces the twisting effect that the torque of the gate places on the mounting post/column when moving through its range of motion. Installation is not recommended on any post or column that is not installed in the ground with concrete.
5. The front mount of the gate operator should be attached to the gate securely and rigid enough to support automation. This may require modifications to the gate design or surface to maintain this secure mounting location.
6. The gate must be plumb, level, and swing freely with minimum effort in both the open and closed directions without hindrance.

SINGLE GATE ILLUSTRATION

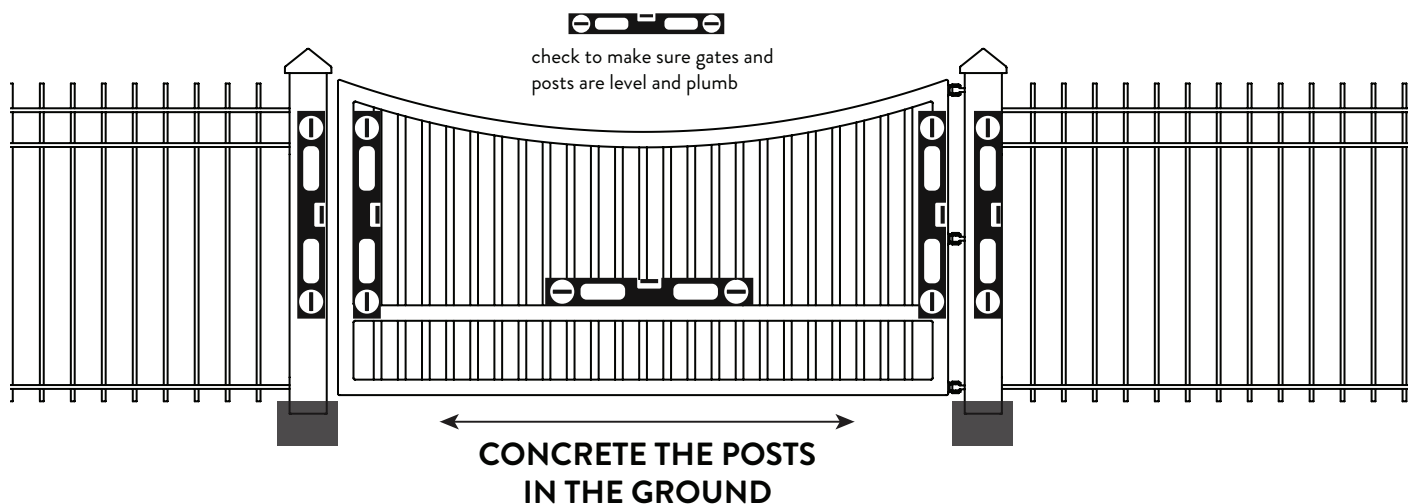

DUAL GATE ILLUSTRATION

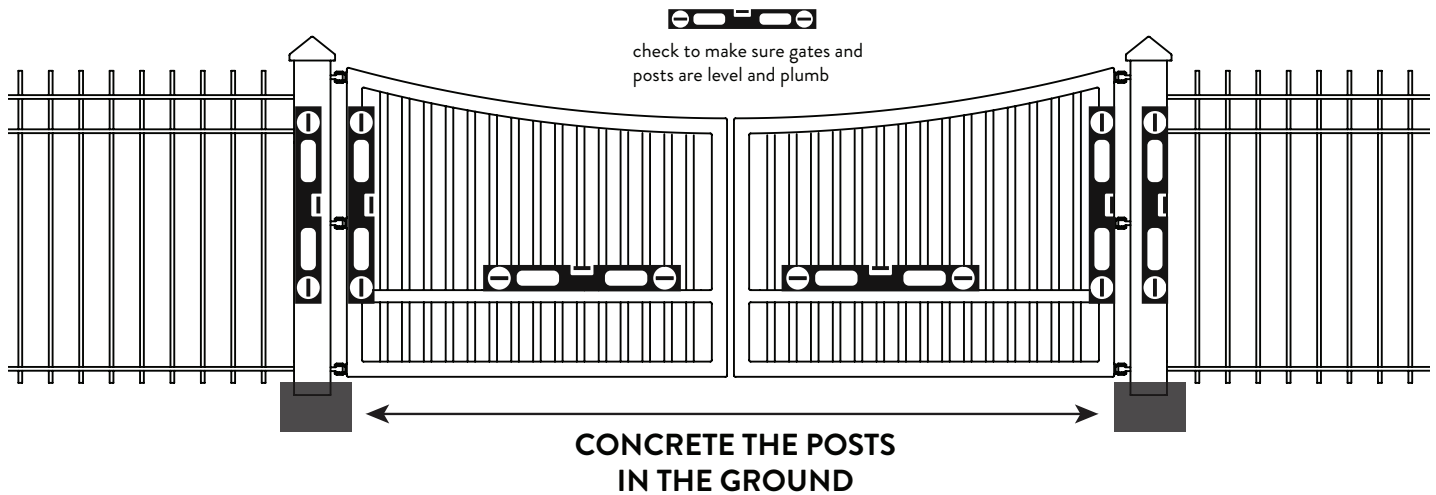
**NOTE**

Push-to-Open installations REQUIRE an accessory Push-to-Open bracket kit (AXPO).

7. Minimum gate post, column, or wall requirements.
 - A. Wooden posts should be at least 6"x6" in size and set in concrete.
 - B. Metal round posts should be at least 3" in diameter and set in concrete.
 - C. Metal square posts should be at least 4"x 4" in size and set in concrete.
 - D. Additional mounting bolts may be required if the included bolts are not at least 1" longer than the diameter of the post.
8. Location and mounting point of control box and battery box. Arm cable length determines how far away from operator arm that you can mount the control box. **THE ARM CABLE CANNOT BE SPLICED OR EXTENDED. PLEASE CALL TECHNICAL SUPPORT (850-898-1411) IF YOU NEED TO EXTEND THE LENGTH OF THE OPERATOR ARM CABLE(S).**
9. Power source to charge the battery (Solar Power vs. AC Power via transformer).
 - A. Never use Solar Panels **AND** an AC transformer on a gate system at the same time or you will damage the main control board and void any warranty.
 - B. The AC transformer is designed for indoor use and must be protected in a weather resistant box (that meets code in your area) if it will be mounted outside.
10. If choosing to use an AC transformer for the battery recharging power source, you should consider the distance from an outlet to your battery box.
 - A. No more than 1000 feet of low voltage wire may be used between the AC transformer and the gate operator system due to electrical losses. If your application exceeds 1000 feet in distance, you must use Solar Panels for your power source to recharge the batteries.
 - B. **WIRE WILL NEED TO BE PURCHASED SEPARATELY.** We offer and recommend 16 gauge **STRANDED, 2-CONDUCTOR** low voltage wire.
 - C. The transformer should be on a circuit that is protected by a GFCI plug or breaker.

11. If choosing to use a Solar Panel for the battery recharging power source, you should consider the distance from the location of the solar panel to your control box.
 - A. You can add up to 100 feet of low voltage wire between the Solar Panel and the control box to reach the recommended 8 hours of direct sunlight a day.
 - B. WIRE WILL NEED TO BE PURCHASED SEPARATELY.** We offer and recommend 16 gauge **STRANDED, 2-CONDUCTOR** low voltage wire.
 - C. Solar Panel should face south away from trees, and other obstructions that would inhibit getting full sun.

12. Consider the following questions when designing your gate opener system:
 - A. How many remote transmitters may you need?
 - B. Will you need a keypad for guests to enter your property or to keep the gate open at times?
 - C. How will guests exit the property?
 - D. How will you and your family exit the property?

DETERMINE MOUNTING LOCATION ON GATE AND SUPPORT BAR

You must determine where to mount the gate operator horizontally on your gate system. Your gate **MUST HAVE A HORIZONTAL BAR ON THE GATE TO MOUNT THE FRONT OF OPERATOR TO.** Each gate is unique and Ghost Controls does not provide this in the kit.

- **TOP MOUNTING** — The gate operator is not recommended to be mounted to the top of the gate because the operator may cause twisting or flexing of the gate while in motion.
- **CENTER LINE MOUNTING** — This is the most common and recommended method for mounting an operator to the gate system.
- **BOTTOM MOUNTING** — The gate operator must be mounted high enough off of the ground so that it does not come in contact with standing or flowing water which will damage the system. This mounting location may cause undesirable twisting or flexing of the gate while in motion.

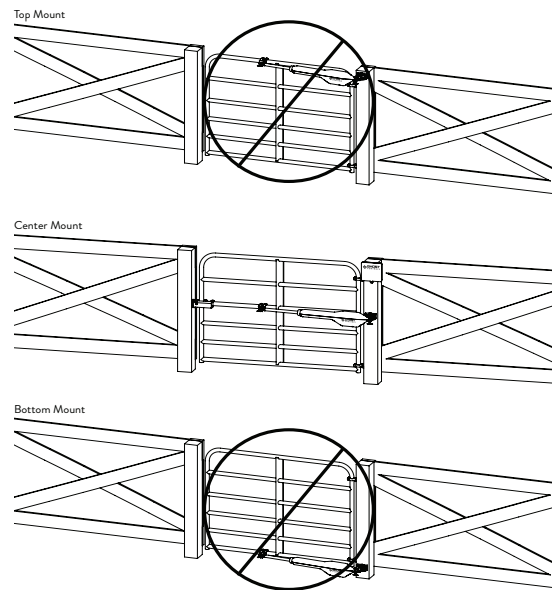

OPERATOR REAR MOUNT INSTALLATION CONSIDERATIONS

The GHOST CONTROLS® Automatic Gate Operator system is designed for installation on rectangular, square, or round posts (for 3" or 4" round steel posts, we offer the **AX3R AND AX4R ROUND POST ADAPTER ACCESSORIES**) or columns. The rear bracket must be level and secured to the mounting post or column with bolts, nuts, and washers because this bracket will experience a tremendous amount of force during operation of the automatic gate operator. Proper positioning of the rear mounting bracket is critical because it determines:

- Leverage and stability of the operator as it applies force to move the gate
- Necessary clearance between the operator in both the closed and open positions

For PULL-TO-OPEN installations, **PLEASE GO TO PAGE 21.**

For PUSH-TO-OPEN installations, **PLEASE GO TO PAGE 41.**

TOOLS NEEDED



Corded/Cordless Drill

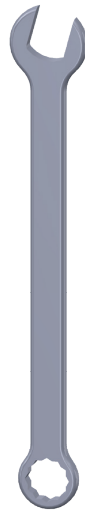

Standard or Metric Wrenches

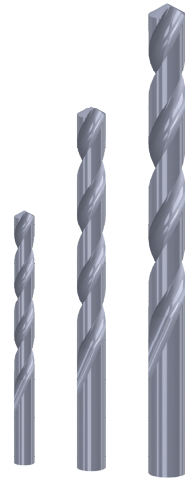

5/16" Drill Bit
7/32" Drill Bit
7/16" Drill Bit
(longer than diameter or thickness of post)



Level

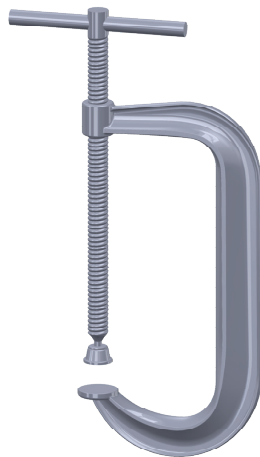

Clamp



Wire Strippers/Cutters



Phillips Head Screwdriver

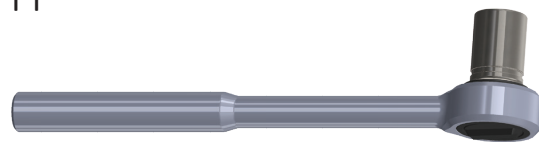

Standard or Metric Socket Set

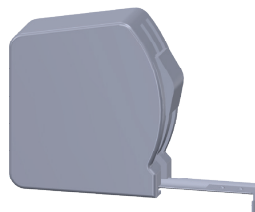

Tape Measure

INCLUDED PARTS IN KIT

PARTS FOR 1ST OPERATOR

Post and Rear Mount Hardware

Post Bracket Hardware:

- M10 - 175mm Hex Screw (Qty 4)
- M10 Flat Washer (Qty 8)
- M10 Locknut (Qty 4)
- Post Bracket Mount (Qty 1)

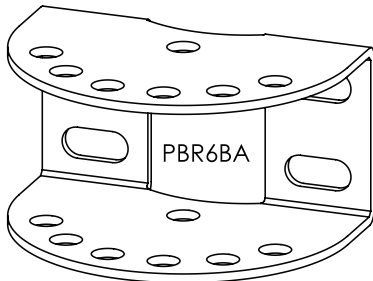
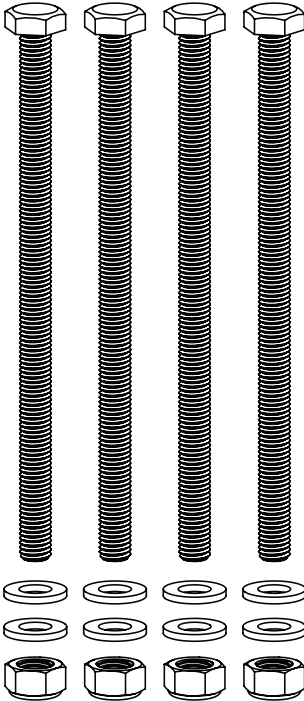

Pivot Bracket Hardware:

- M10 - 75mm Hex Screw (Qty 2)
- M10 Flat Washer (Qty 4)
- Pivot Bracket Spacers (Qty 2)
- M10 Locknut (Qty 2)
- Pivot Brackets (Qty 2)

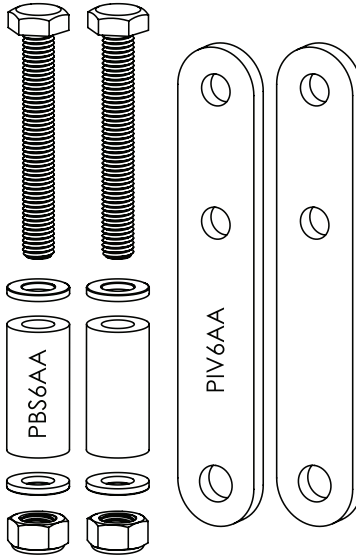

Rear Mounting Hardware:

- 12xmm x 75mm Clevis Pin (Qty 1)
- 12mm I.D. Nylon Spacer (Qty 1)
- Clevis Hairpin (Qty 1)



Gate and Front Mount Hardware

Gate Mounting Hardware:

- M8 - 65mm Hex Screw (Qty 2)
- M8 Flat Washer (Qty 4)
- M8 Hex Nut (Qty 2)
- Gate Mount Bracket (Qty 1)

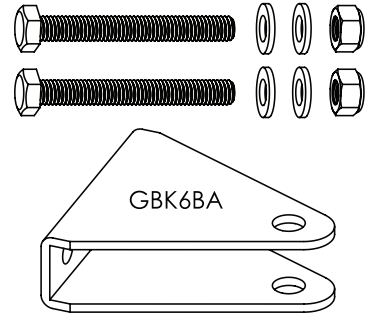

Front Mounting Hardware:

- 10mm x 40 mm Clevis Pin (Qty 1)
- 10mm I.D. Nylon Spacer (Qty 1)
- Clevis Hairpin (Qty 1)

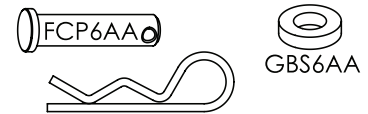

Estate Bracket (Qty 1)

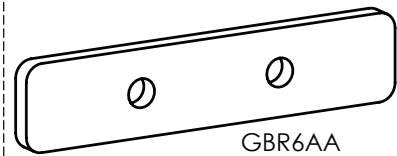

Control Box Mounting

- Panhead Phillips Screws (Qty 4)
- Cable Ties (Qty 5)

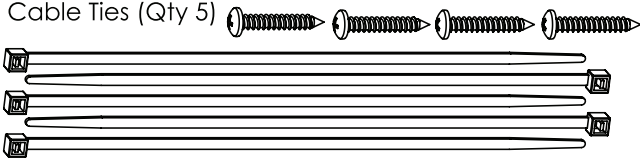

Control Box



AC Transformer:



Opener Arm:



5 Button Remote: (1)



INCLUDED PARTS IN KIT (DUAL)

PARTS FOR 2ND OPERATOR (DUAL KITS ONLY)

Post and Rear Mount Hardware

Post Bracket Hardware:

- M10 - 175mm Hex Screw (Qty 4)
- M10 Flat Washer (Qty 8)
- M10 Locknut (Qty 4)
- Post Bracket Mount (Qty 1)

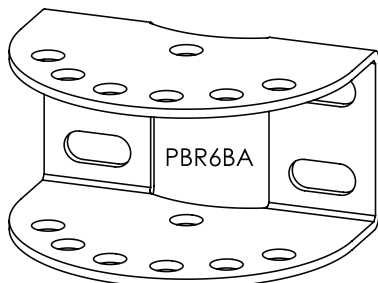
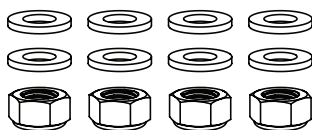
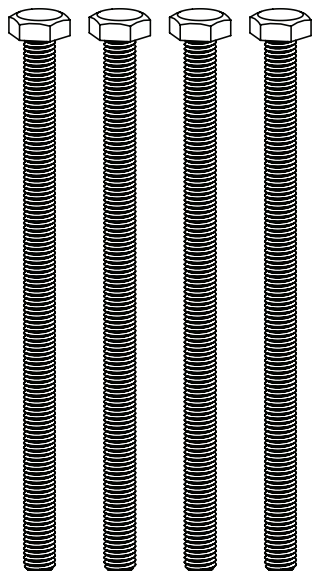

Pivot Bracket Hardware:

- M10 - 75mm Hex Screw (Qty 2)
- M10 Flat Washer (Qty 4)
- Pivot Bracket Spacers (Qty 2)
- M10 Locknut (Qty 2)
- Pivot Brackets (Qty 2)

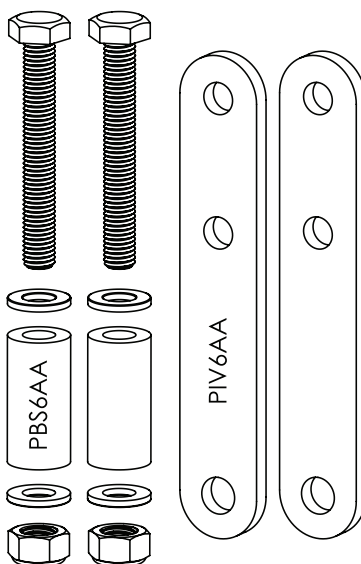

Rear Mounting Hardware:

- 12mm x 75mm Clevis Pin (Qty 1)
- 12mm I.D. Nylon Spacer (Qty 1)
- Clevis Hairpin (Qty 1)



Gate and Front Mount Hardware

Gate Mounting Hardware:

- M8 - 65mm Hex Screw (Qty 2)
- M8 Flat Washer (Qty 4)
- M8 Hex Nut (Qty 2)
- Gate Mount Bracket (Qty 1)

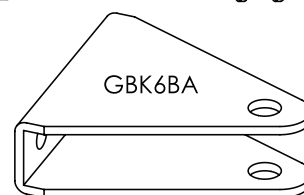
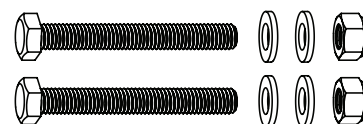

Front Mounting Hardware:

- 10mm x 40 mm Clevis Pin (Qty 1)
- 10mm I.D. Nylon Spacer (Qty 1)
- Clevis Hairpin (Qty 1)



Estate Bracket (Qty 1)

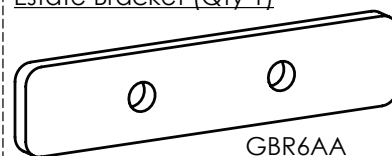

Positive Stop Gate Bracket (Qty 1)

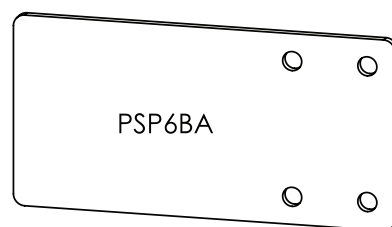

- M8 - 65mm Hex Screw (Qty 4)
- M8 Flat Washer (Qty 8)
- M8 Hex Nut (Qty 4)

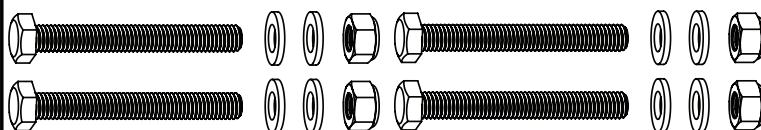

5 Button Remote: (1)

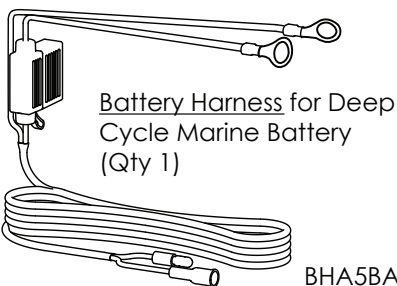

Battery Harness for Deep Cycle Marine Battery (Qty 1)

BHA5BA

2nd Opener Arm:



PULL TO OPEN INSTALLATION

OPERATOR ARM INSTALLATION

*Your Ghost Opener Arm might look different than illustrations throughout this manual

Gate Operator System View Looking Straight Down from Above

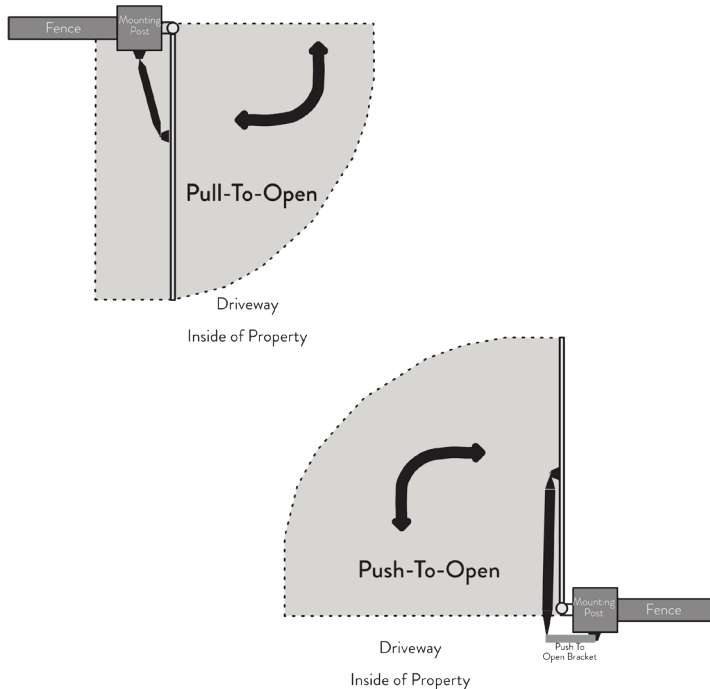

NOTE

Wheels cannot be used with any Ghost Controls® gate opener system!

For gates weighing over 200 lbs. ball bearing hinges are recommended.

Operator is not for use on solid panel privacy gates.

PULL-TO-OPEN: GATE SWINGS TO OPEN INSIDE PROPERTY

The dimensions and step-by-step instructions that follow are for mounting the GHOST CONTROLS® Gate Operator in a **PULL-TO-OPEN** installation system to a standard gate that swings into the property.

FOR PUSH-TO-OPEN APPLICATIONS, PLEASE GO TO PUSH-TO-OPEN APPLICATION ON “PUSH TO OPEN INSTALLATION” ON PAGE 41.

STEP 1. Establish and mark the horizontal center lines of the gate and the post for proper alignment of gate brackets.

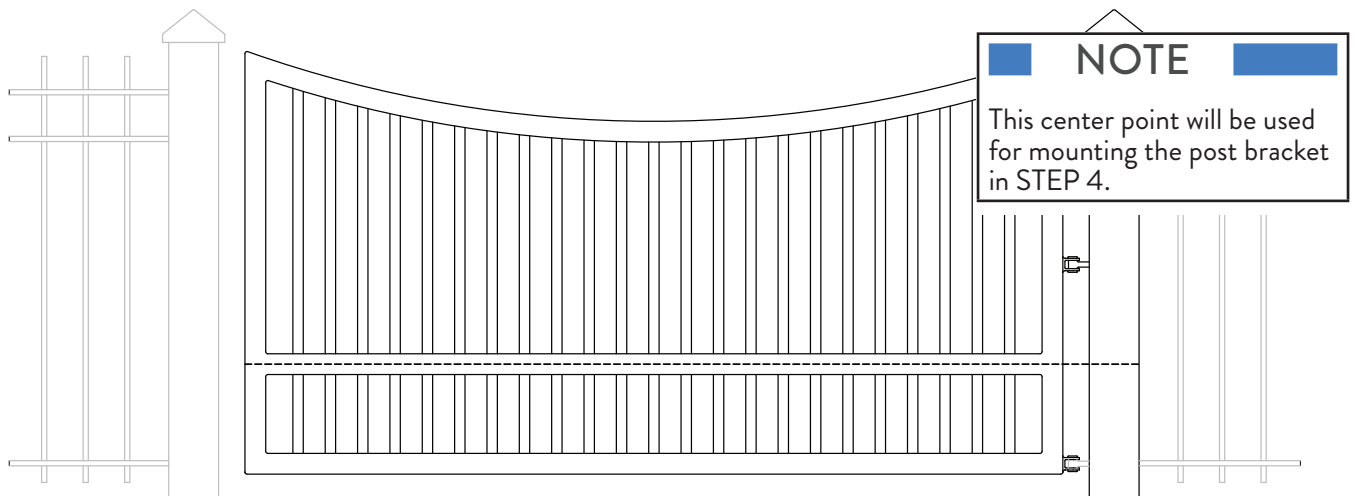

STEP 2. Post bracket pre-assembly.

Insert the M10x1.5x75mm bolt and M10 washer through the hole that is closest to the post on the post bracket. Bolt should then go through first pivot bracket, pivot spacer, second pivot bracket, and exit bottom hole of post bracket as shown below. Fasten a M10 washer and M10 locknut on the end of the bolt. **DO NOT** overtighten the nut because the pivot bracket may need to be adjusted later. An additional bolt will be added in Step 4 to lock the pivot brackets in place.

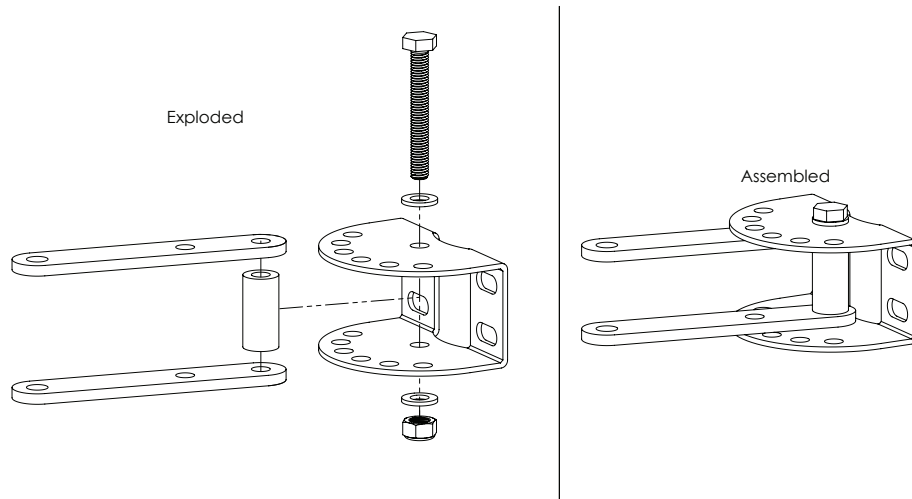
**STEP 3.** Clamp post bracket to post for alignment.

After the post bracket is pre-assembled and the horizontal centerline has been marked on the post as referred to in STEP 1 and 2, proceed to **CLAMP THE POST BRACKET TO THE MARKED CENTER LINE (CL)** on the post.

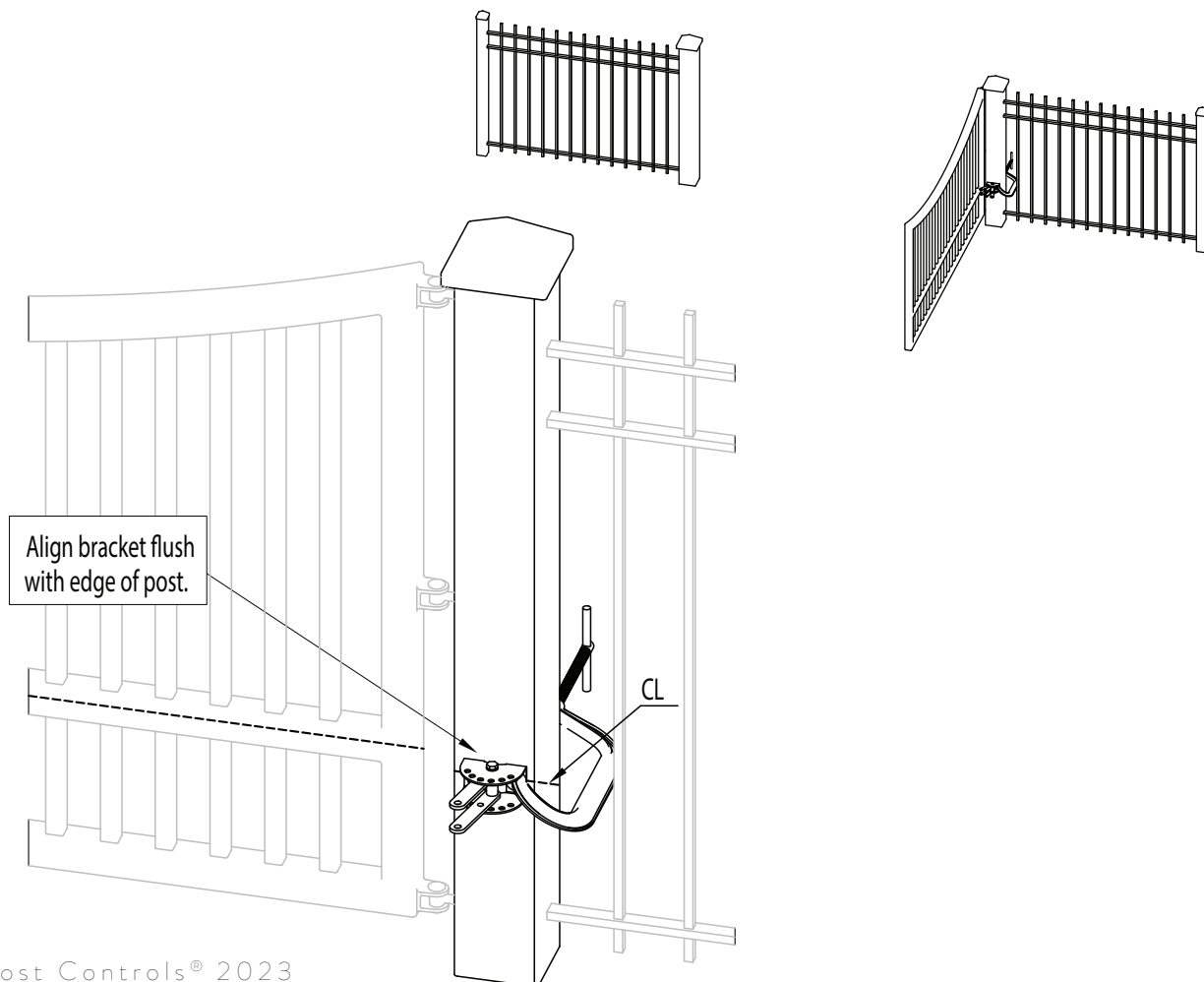

NOTE

For round wooden post installations we recommend notching the wooden post for proper installation of the post bracket. Follow the diagram for proper notching of a round post.

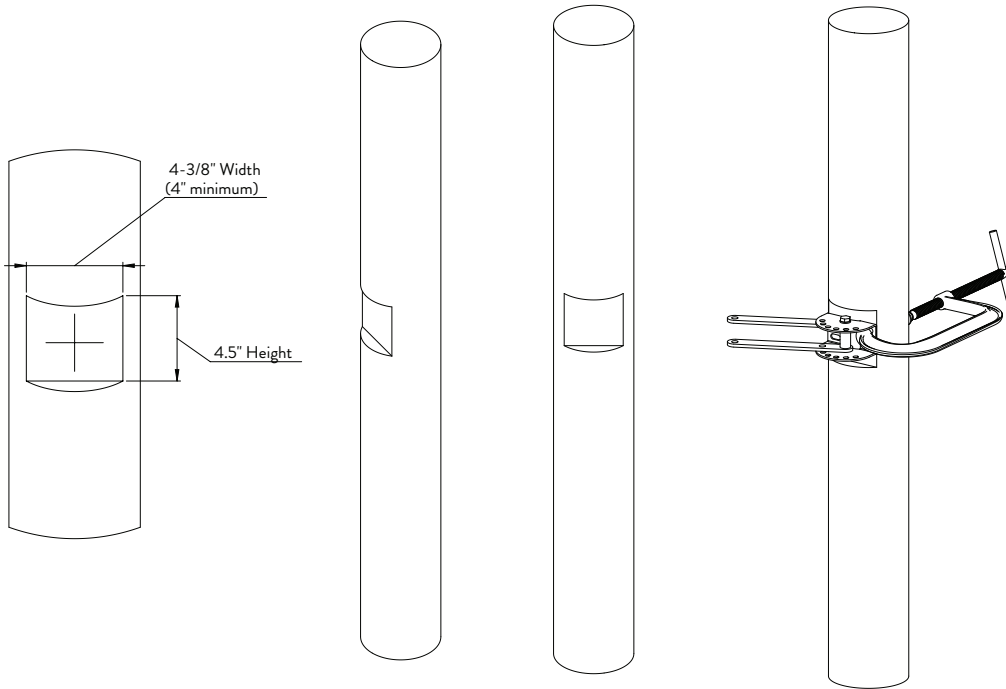

NOTE

For 3" and 4" round steel posts, we offer the **AX3R AND AX4R** round post adapter accessories (sold separately). See illustration using the round post adapter below.

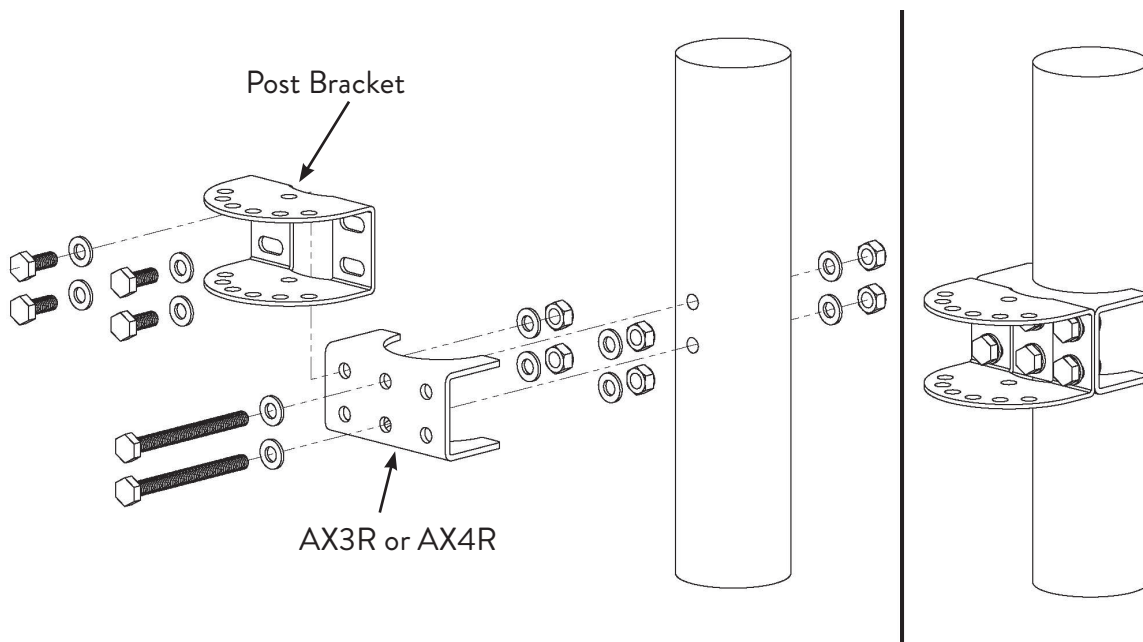

STEP 4. Verifying minimum of 4" Gate Clearance and finishing rear post mount bracket assembly. **If the clearance is less than 4", you will need to adjust the pivot brackets so that you have at least 4" of clearance, otherwise, you will not have minimal mechanical advantage needed to move the gate.**

Once the clearances are correct, **place the secondary bolt into the post mount and pivot bracket, as shown below.**

Insert the M10x1.5x75mm bolt and M10 washer through the post bracket hole, then first pivot bracket, pivot spacer, second pivot bracket, and exit out bottom hole of post bracket as shown below. Fasten a M10 washer and M10 locknut on the end of the bolt. **Finish by tightening both bolts on post bracket.**

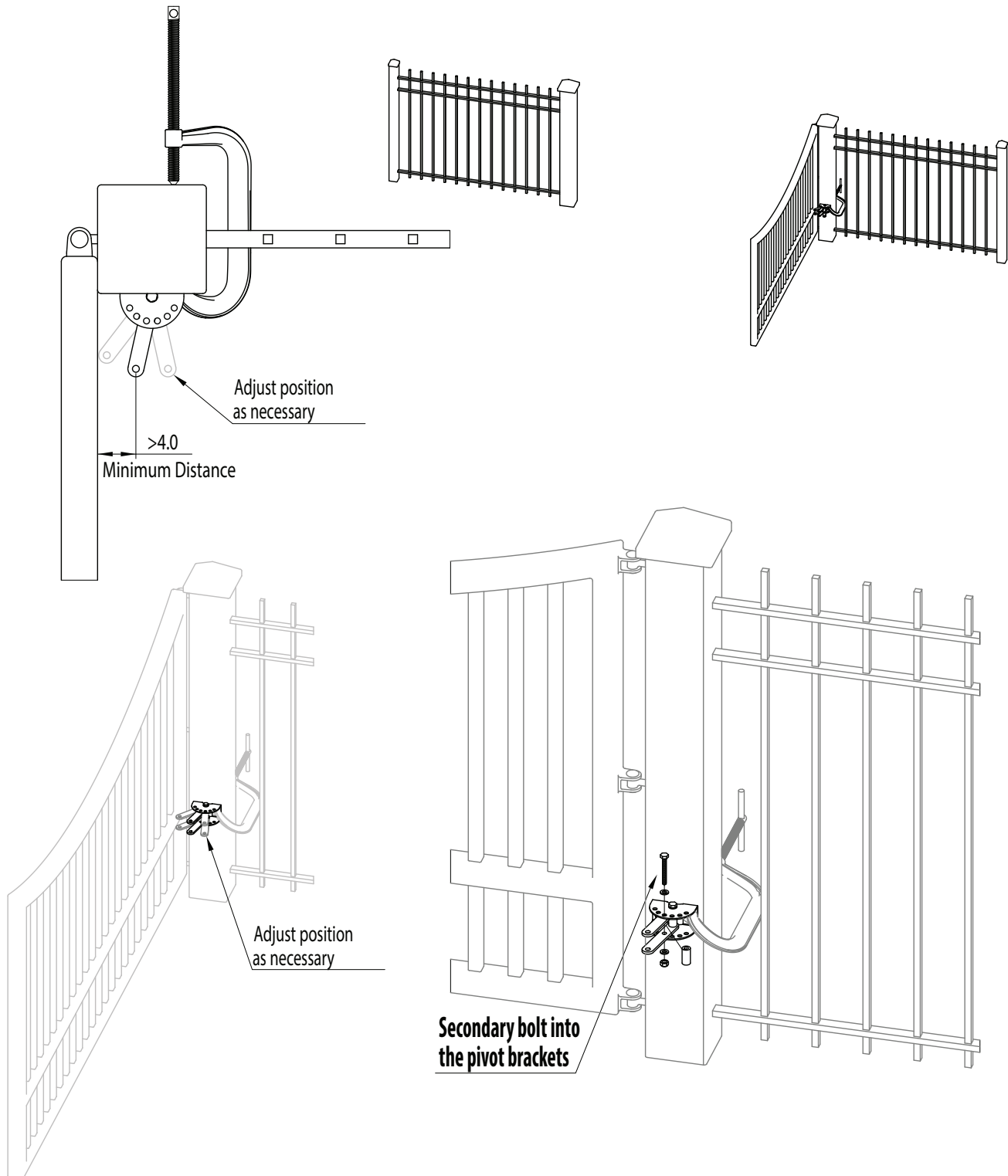

STEP 5. Drilling rear post bracket holes and bolting.

- A. With the post bracket still clamped to post, mark the center of the bracket slots. Remove the bracket.
- B. You will need a 7/16" drill bit and drill the (4) holes to mount the rear post bracket to the post.

TIP: Drill each hole one at a time and insert a bolt through to ensure that the holes are large enough and all aligned.

- C. Insert (1) M-10-175mm bolt, and (1) flat washer through the rear post bracket hole on the post and secure on backside with (1) flat washer and (1) M10 locknut as shown and loosely tighten to secure the rear bracket to the post. Repeat this 3 more times for the other bolts. Once all 4 bolts are in place, with the bracket aligned with the bolts in the center of the slots, firmly tighten all four bolts.

NOTE: Certain applications may require the use of different hardware (not included)

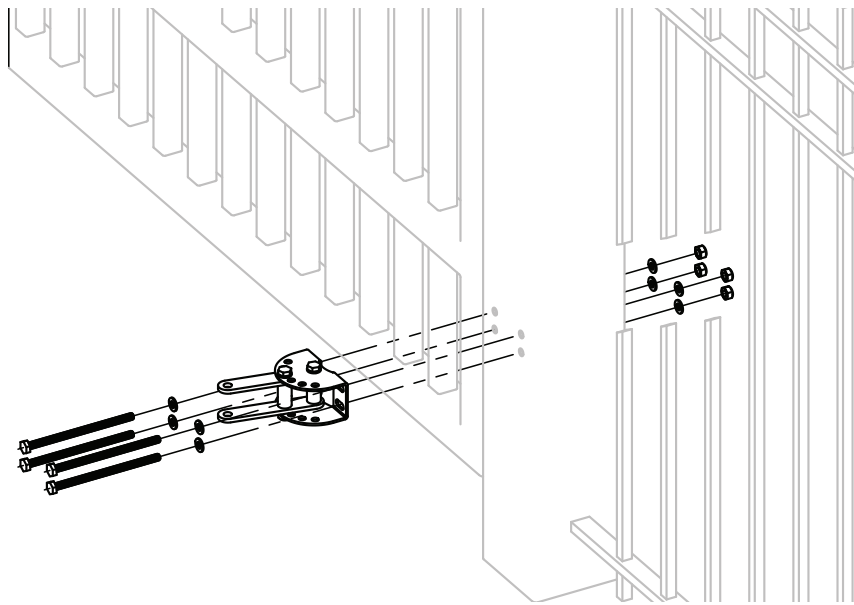

STEP 6. Install rear of operator on rear post mount.

Insert clevis pin, nylon spacer and clevis hairpin as shown below to secure the rear of the operator to the post.

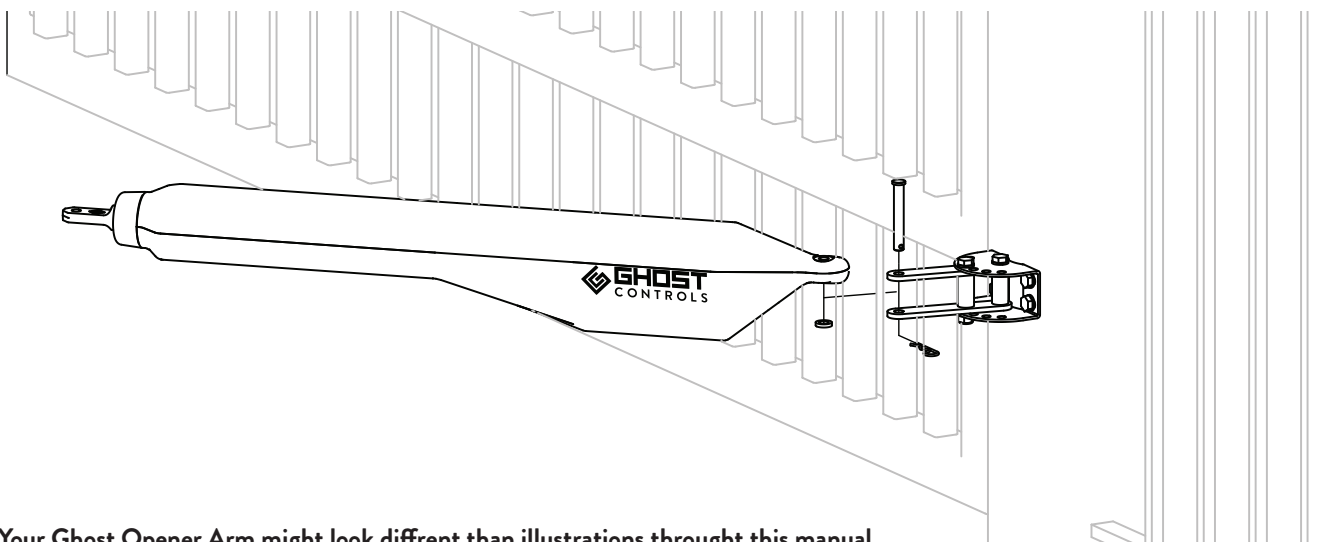

*Your Ghost Opener Arm might look different than illustrations throughout this manual

INSTALLING THE CONTROL BOX AND *BATTERY BOX TO YOUR PULL-TO-OPEN SYSTEM

(*Shown below using a BATTERY BOX KIT (ABBT2), NOT INCLUDED)

STEP 7. Determine the mounting location for the control box and *optional battery box.
The battery and control box must be located within 4 feet of each other. Then install.

NOTE

Mount the control and optional battery box a minimum of 3 feet above the ground to keep dirt and water from damaging the control board and within 4 feet of the operator arm in order for the operator cable to reach the control box.

- A. Pre-drill (4) holes (7/32" drill bit) in backside of control and optional battery box, and through the fencing where you will be securing the control and battery box to.
- B. Now use the (4) supplied phillips screws for both boxes to mount the control and optional battery box to the fence.

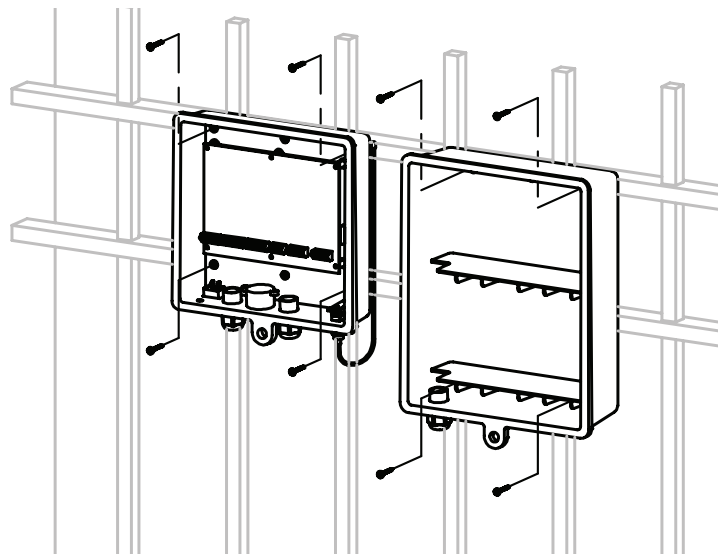

- C. Make sure the on/off switch on the bottom of control box is in the off position.

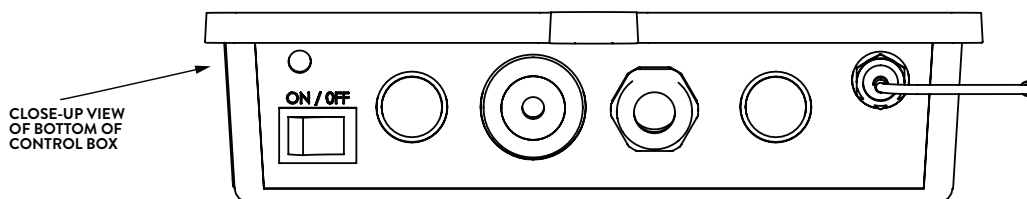

CONNECTING AND INSTALLING THE BATTERY AND BATTERY HARNESS

IMPORTANT

YOU NEED A 12V DEEP CYCLE MARINE/AUTOMOTIVE BATTERY OR THE ABBT2 BATTERY BOX KIT. SYSTEM WILL NOT OPERATE WITHOUT BATTERY INSTALLED AND CONNECTED AT ALL TIMES.

STEP 8. Insert battery harness through strain relief in control box and attach to the control board.

- A. Route the battery harness cable through the strain relief on the bottom of the control box and connect the bullet connectors (red to red, black to black) to the control board harness.

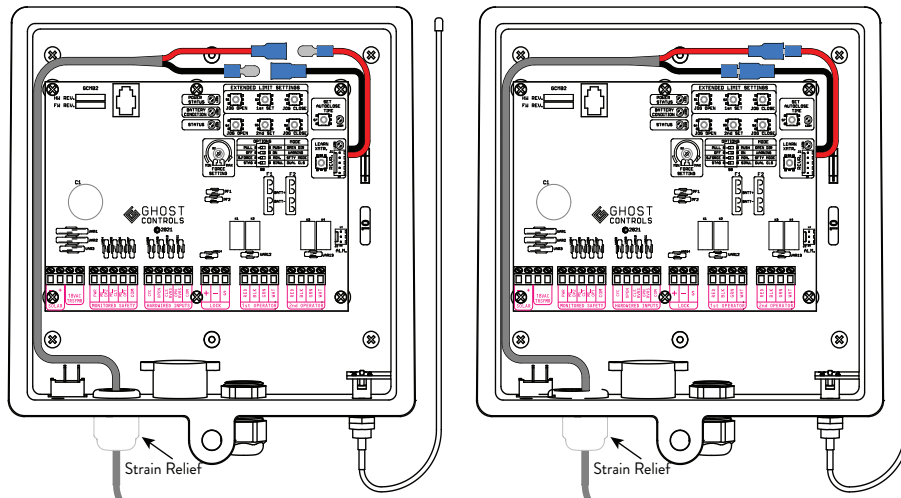

- B. Connect the terminal leads of the battery harness to your battery.

Connect the battery harness from the control box to the battery.

Make sure **RED WIRE CONNECTS TO BATTERY'S (+) TERMINAL. (CONNECT FIRST)**

Make sure the **BLACK WIRE CONNECTS TO BATTERY'S (-) TERMINAL.**

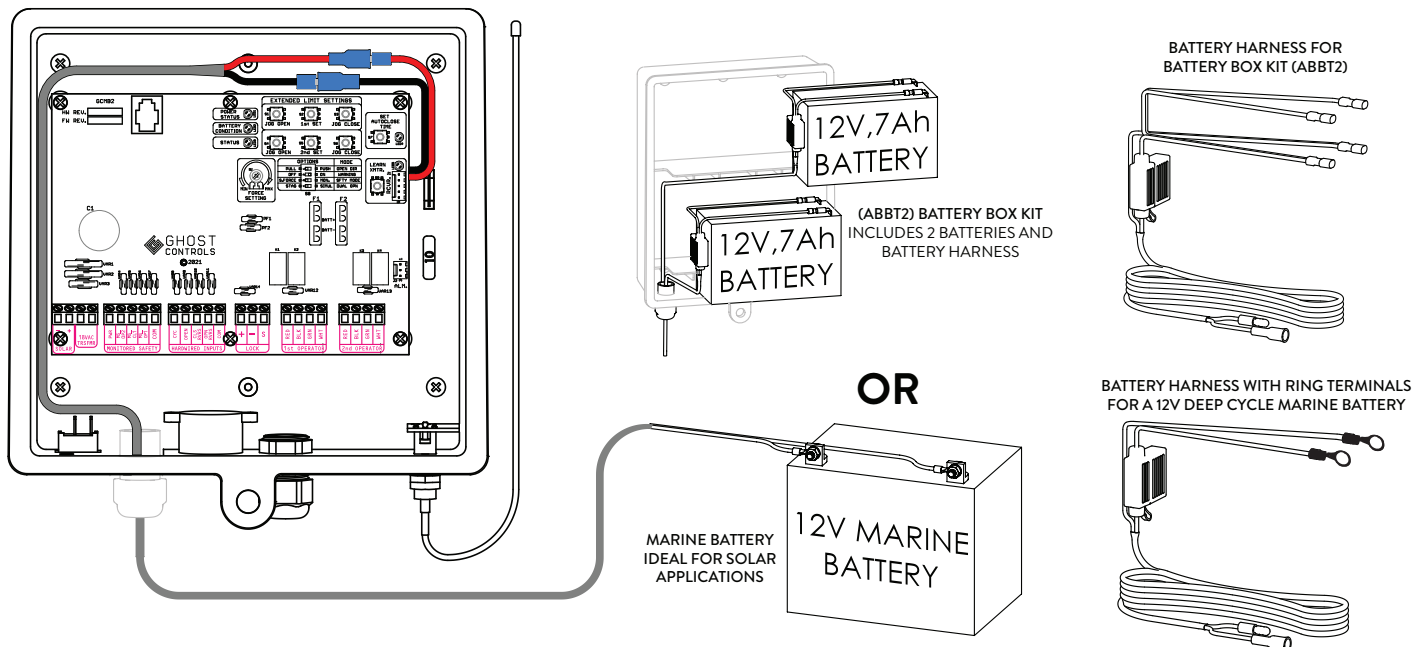

CONNECTING OPERATOR ARM TO CONTROL BOX

STEP 9. Insert the operator cable into the control box.

- A. Route the operator cable through the strain relief and into the control box.
- B. Connect the operator wires to the control board. Find the 1st operator screw terminal on control board and insert the red, black, green and white wires (left to right) into the matching color coded terminals and tighten each of the screws so that the wires do not come loose and fall out.
- C. Make sure wires are not inserted too far into the terminal slots and that the wire insulation is not interfering with contact to the system control board.
- D. Tighten strain relief nuts on the control box to close the seals around the wires.

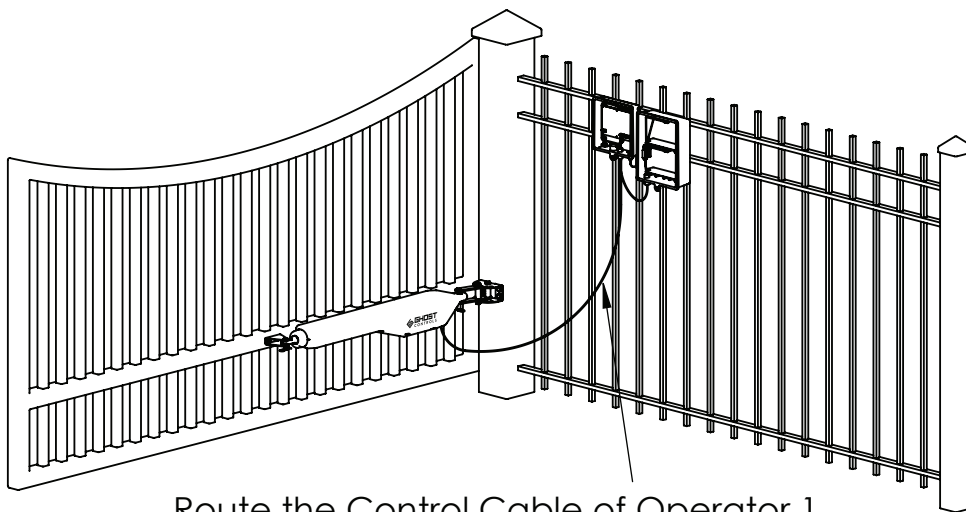

Route the Control Cable of Operator 1 through the strain relief of the Control Box.

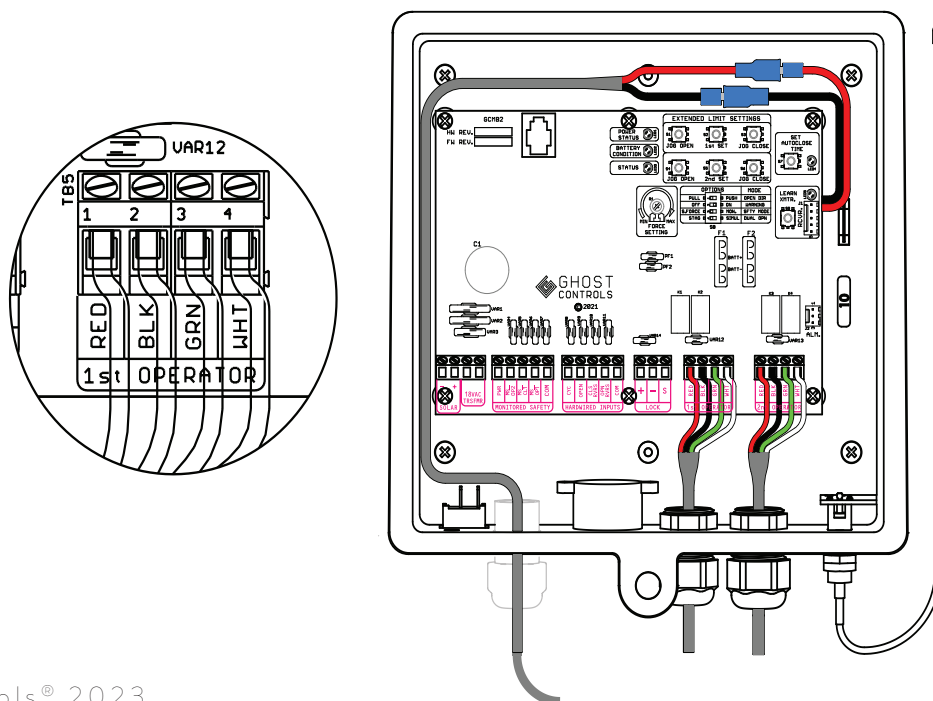

PREPARING THE GATE SYSTEM CONTROLLER

The gate system control board provides one convenient place to make all of your system connections and to change any settings that you desire to personalize how your automatic gate opener system operates at your home or property. This main board (shown below) is located inside of the control box of your system and will be referred to in detail through the next few sections. Because this control box may be mounted within reach of children or potential vandals, we recommend a padlock to securely lock this box in the closed position to prevent tampering. **NOTE: BEFORE PROCEEDING MAKE SURE THE ON/OFF SWITCH ON BOTTOM OF CONTROL BOX IS IN THE OFF POSITION**

NOTE: Your control board may have minor differences than the control board shown.

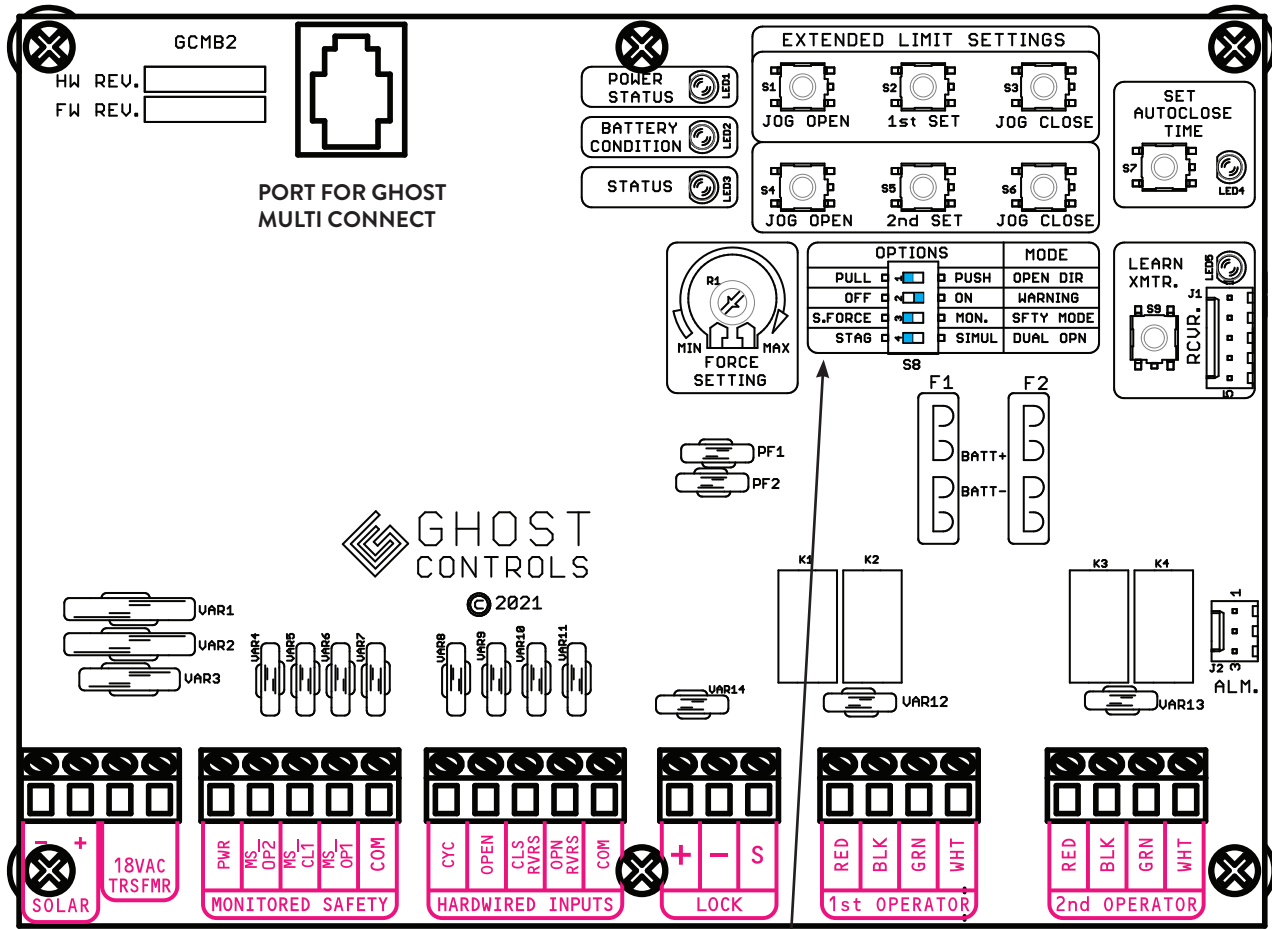

STEP 10. Check the system DIP switch settings and verify that they are in the correct positions as shown.

DIP Switch #	OFF Position	ON Position
1	<input checked="" type="checkbox"/> Factory Default: Pull-To-Open	<input type="checkbox"/> Push-To-Open
2	<input type="checkbox"/> Warning Disabled	<input checked="" type="checkbox"/> Factory Default: Warning Enabled
3	<input checked="" type="checkbox"/> Factory Default: SafeForce® Mode	<input type="checkbox"/> Monitored External Safety Devices Mode
4	<input checked="" type="checkbox"/> Factory Default: Delay Open 2nd Arm	<input type="checkbox"/> Simultaneous Open

DIP SWITCH OPTION SETTINGS. There are four DIP Switches located on the main control board (shown) that must be positioned properly for your particular installation

OPTIONS			MODE
PULL	<input checked="" type="checkbox"/>	PUSH	OPEN DIR
OFF	<input checked="" type="checkbox"/>	ON	WARNING
S.FORCE	<input checked="" type="checkbox"/>	MON.	SFTY MODE
STAG	<input checked="" type="checkbox"/>	SIMUL	DUAL OPN

A. DIP #1 OPEN DIRECTION. The opening direction of the gate operator is determined by DIP#1.

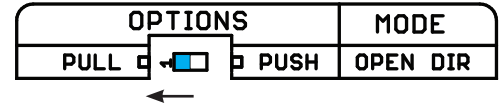

DIP Switch #	OFF Position	ON Position
1	Pull-To-Open (Factory Default): Gate is pulled to open into your property.	Push-To-Open Installation: Gate is pushed to open away from your property.

B. DIP #2 ALARM WARNING. The warning alarm is determined by DIP#2.



DIP Switch #	OFF Position	ON Position
2	Warning Disabled: AUTOCLOSE and initial gate movement alarm warning is disabled. This does not disable the alarm warning for consecutive obstruction as required by UL325 safety standard.	Warning Enabled (Factory Default): AUTOCLOSE and initial gate movement warning is enabled.

C. DIP #3 MONITORED SAFETY DEVICES. Keep Switch To The Left (Factory Setting) Unless Using Monitored External Safety Devices Then Switch To The Right.

YOUR SYSTEM WILL NOT WORK IF SAFTEY MODE IS ON AND YOU DO NOT HAVE MONITORED EXTERNAL SAFETY DEVICES CONNECTED.



DIP Switch #	OFF Position (FACTORY SETTING)	ON Position
3	Patent-pending SafeForce® Mode (Factory Default): Force output is limited to ensure safe operation as specified by Type C in UL325 requirement.	Monitored Safety Mode: Monitored safety devices required / Compatible GHOST CONTROLS® safety devices only. Monitored safety devices must be present and operate properly as specified by Type B1 or B2 in UL325 requirement. See monitored safety device connection in the monitored photo eye instructions manual for more details.

D. DIP #4 DUAL (BI-PARTING) GATE OPENING SEQUENCE. The gate opening sequence for dual gate opener systems only is determined by DIP#4. **The SECOND arm will always CLOSE first before the FIRST arm.**

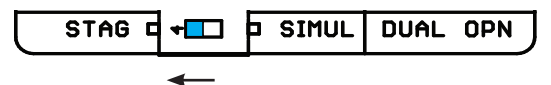

DIP Switch #	OFF Position	ON Position
4	Delay Open (Factory Default): FIRST arm will open before the SECOND arm.	Simultaneous Open: Both the FIRST arm and the SECOND arm will simultaneously OPEN. If Gate Lock is installed, the system will ignore this DIP switch setting and default to delay open on the SECOND arm.

TURN CONTROL BOX ON. YOU SHOULD HEAR A SERIES OF BEEPS AS THE SYSTEM IS TURNED ON

STEP 11. Locate the jog buttons at the top right of control box to test the arm and connections. Press the jog close button to extend the arm 3-4 inches out.

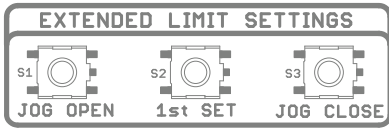

USE FOR FIRST ARM INSTALLATION

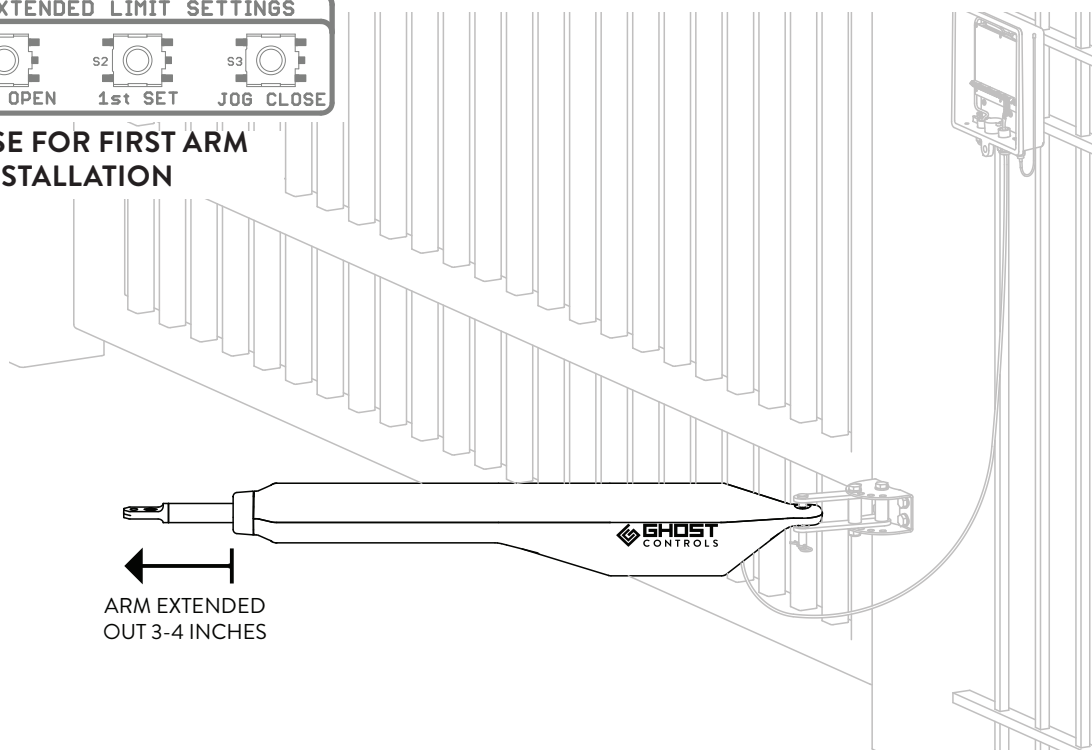

ARM EXTENDED OUT 3-4 INCHES

STEP 12. Use the remote transmitter that came in your kit and press first button to fully retract the arm. The arm will stop on its own.

The arm in the fully retracted position will determine the **OPEN** position of the gate.

NOTE

The arm has an internal limit switch that is fixed and is not adjustable.

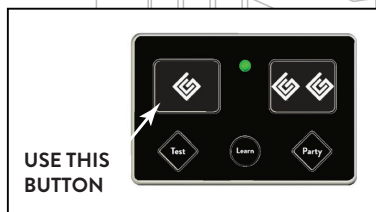

USE THIS BUTTON

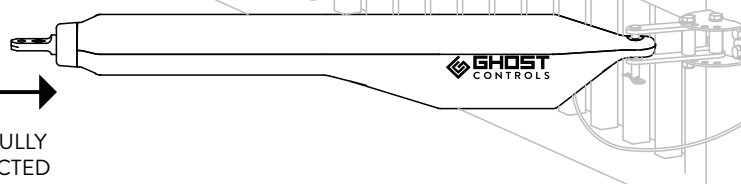

ARM FULLY RETRACTED

*Your Ghost Opener Arm might look different than illustrations through this manual

WARNING

DO NOT SCREW THE OPERATOR ARM IN OR OUT TO ADJUST YOUR GATE POSITION. DOING SO CAUSES THE SYSTEM TO NOT FUNCTION PROPERLY.

TURN THE CONTROL BOX OFF

STEP 13. Attach the front mount bracket to the operator. The gate must remain in the desired open position.

OPEN THE GATE TO THE DESIRED OPEN POSITION

- A. Temporarily assemble the front mount of the gate by inserting the supplied 10mm x 40mm clevis pin, 10mm I.D. nylon spacer, and clevis hairpin through the gate bracket.

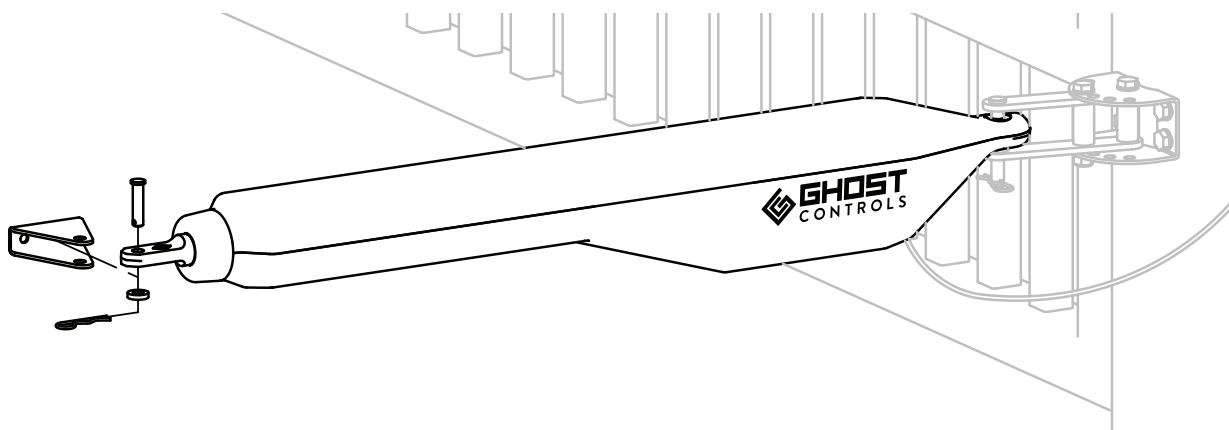

*Your Ghost Opener Arm might look different than illustrations through this manual

NOTE

ALTERNATE TUBE GATE BRACKETS FOR MOUNTING TUBULAR GATES. (NOT FOR USE WITH FLAT PANEL GATES) see below image. Tube brackets (AXTB) sold separately.

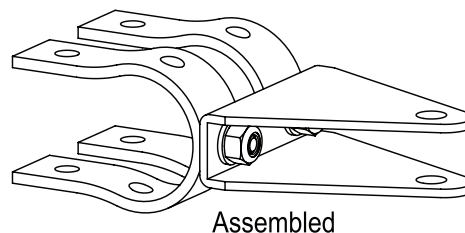
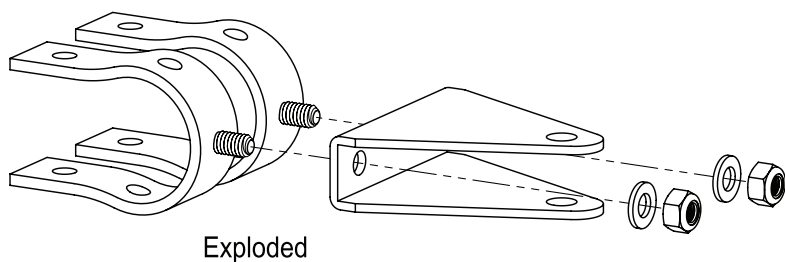

STEP 14. Mounting the **FRONT MOUNT AND ESTATE BRACKET** to the gate.

OPEN THE GATE TO THE DESIRED OPEN POSITION

(this will be the position that your gate will always open to)

- A. Line up the pre-assembled front mount gate bracket over the center-most bar on your gate and **mark the center location of the outermost hole on the gate.**

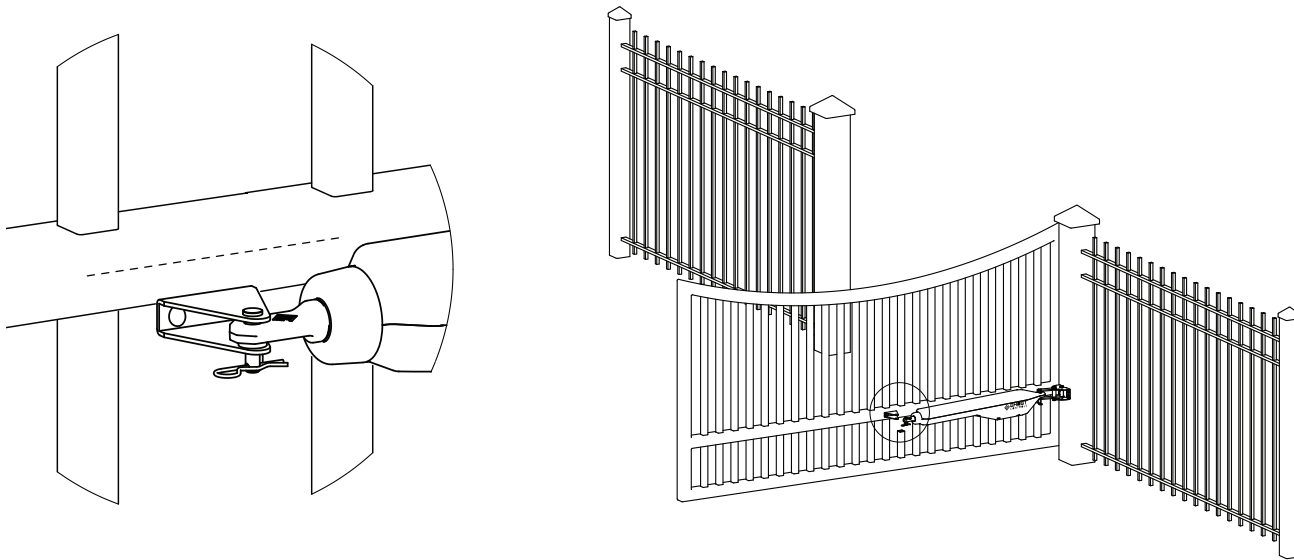

WARNING

DO NOT SCREW THE OPERATOR ARM IN OR OUT TO ADJUST YOUR GATE POSITION. DOING SO CAUSES THE SYSTEM TO NOT FUNCTION PROPERLY.

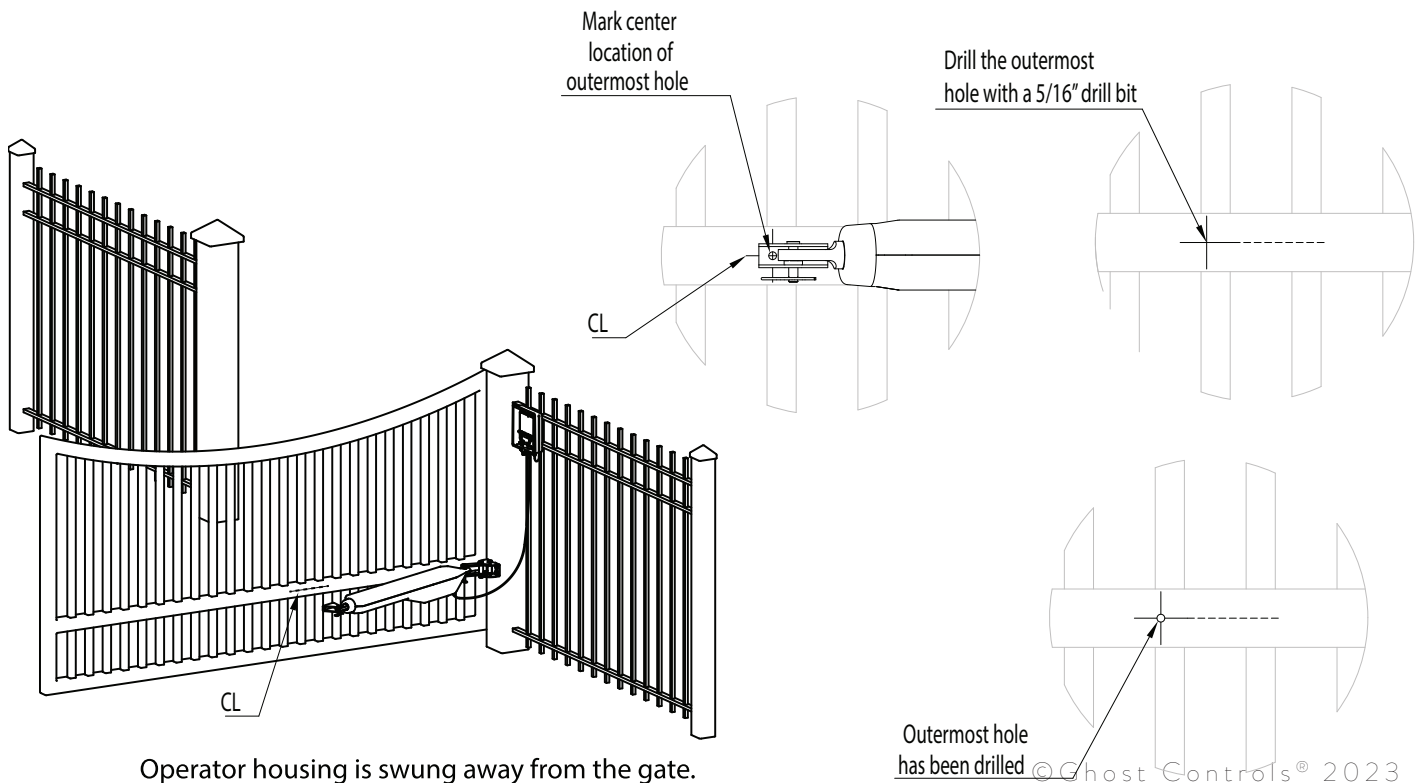

- B. Install the front mount gate bracket and estate bracket** on the gate by aligning the outermost hole of both brackets and inserting (1) M8 x 65mm flat washer, and (1) M8 nylon locknut through both the estate and front mount bracket, as show below. Tighten to secure the brackets to the gate. **MAKE SURE GATE IS STILL IN OPEN POSITION (arm fully retracted).**

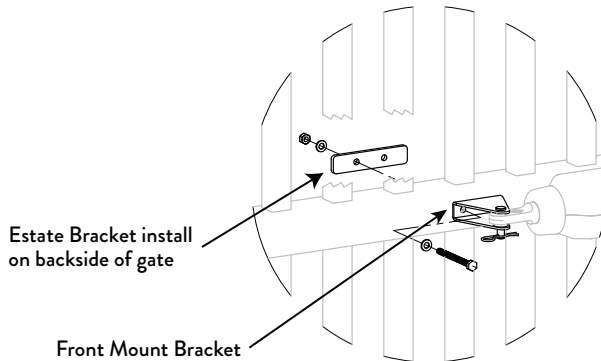

- C. Disconnect operator from gate bracket and swing away from the gate.**

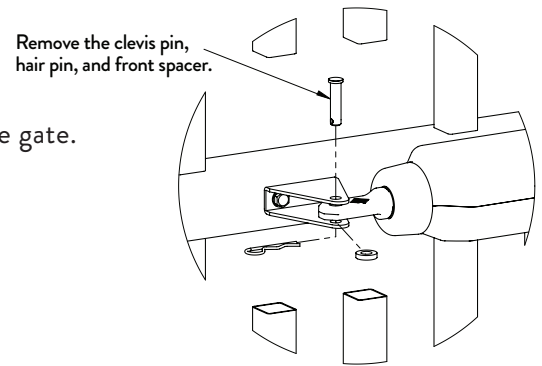

- D. Assemble clevis pin, front spacer and hair pin to operator to prevent loss.**

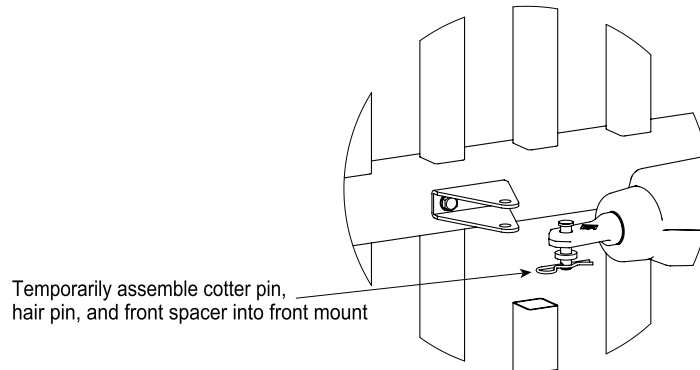

- E. Now you can mark and drill the inner most hole on the front mount bracket with a 5/16" drill bit, shown below. NOTE: It might be necessary to remove the bracket to drill hole.**

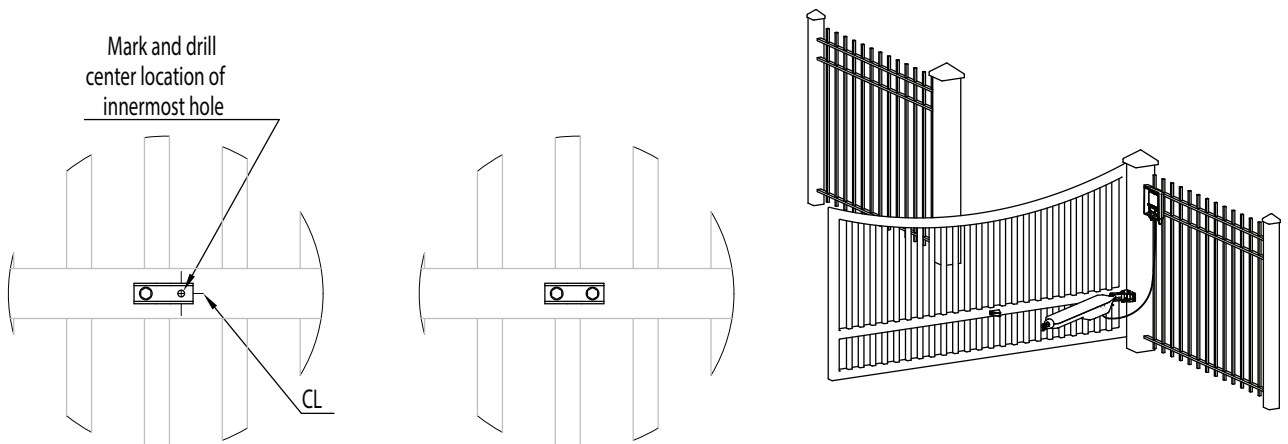

- F. Align the innermost hole of the estate and front mount brackets and insert (1) M8 x 65mm flat washer, and (1) M8 nylon locknut through both holes and tighten to secure the bracket to the gate. **YOUR FRONT MOUNT AND ESTATE BRACKET SHOULD NOW BE ATTACHED AND SECURED TO THE GATE.**

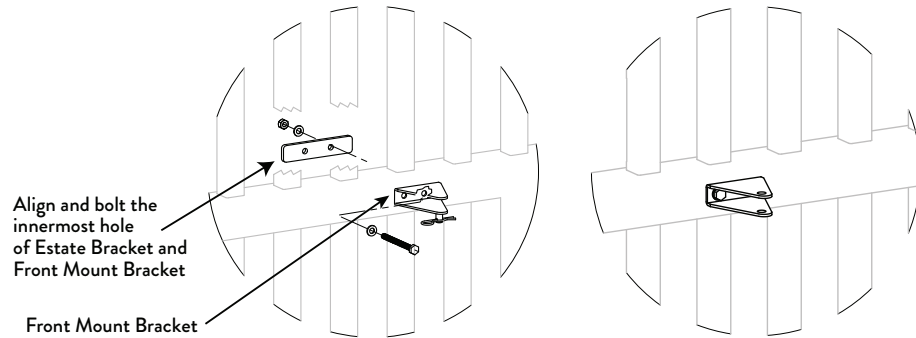

- G. Align and attach arm of operator to the secured front mount bracket, as shown below. **Make sure all parts installed during installation are tightened down.**

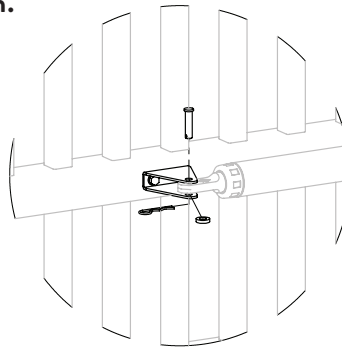

STEP 15. PROCEED TO PROGRAMMING THE CLOSED LIMIT SETTING.

PROGRAMMING THE CLOSED LIMIT: PULL-TO-OPEN

This is the most common installation. The **CLOSED** limit is when the operator is extended and the gate is in the closed position.

IMPORTANT

ONLY THE OPERATOR ARMS' EXTENDED LIMIT IS ADJUSTABLE AND CAN BE SET WITH THE CONTROL BOARD. THE ARMS' RETRACTED POSITION IS FIXED AND IS NOT ELECTRONICALLY ADJUSTABLE.

THE OPEN POSITION IS SET BY HARDWARE MOUNTING ONLY. Please refer to the hardware installation to make sure the retracted position is properly set/installed.

Installation Type	Retracted Position	Extended Position
Pull-To-Open	Gate at the fully OPEN position (not electronically adjustable)	Gate at the CLOSED position (electronically adjustable)

TURN THE CONTROL BOX ON SETTING THE CLOSED LIMIT

- A.** Locate the **1st SET limit settings** on the control board and press and hold the **JOG CLOSE** button for the until the gate reaches the **desired closed position**. The gate can move only if pressure is maintained. Releasing the **JOG** button will stop the gate immediately.

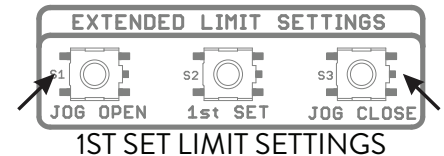

- B.** Both **JOG OPEN** or **JOG CLOSE** buttons are needed to 'fine-tune' your **desired CLOSED position**.
- C.** Press and hold the 1st set limit button on the control panel until it beeps, then release.

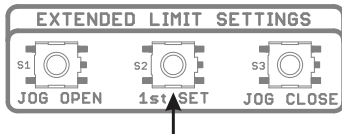

- D.** Press the transmitter button to activate the gates and let the gate open fully. You should hear a single beep. When the gate reaches its **OPEN** position, the control board will sound a single beep, confirming the **CLOSED** limit has been set.

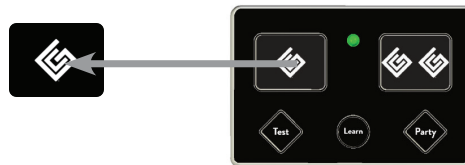

- E.** Confirm the newly programmed **CLOSED** limit by pressing the remote transmitter button to activate the gate and confirm the closed position has been set correctly. This limit is stored and remembered even if you lose power.



- F.** Repeat if needed to change your desired **CLOSED** position.
- G.** Test your system with the remote transmitter to make sure it opens and closes without errors.

CONNECTING THE AC TRANSFORMER

AC Transformer charges the system battery. System will not operate without a 12V battery installed and connected.

IMPORTANT
DO NOT USE THE AC TRANSFORMER AND SOLAR POWER AT THE SAME TIME!

NOTE
TO COMPLETE STEP 21 YOU WILL NEED 16 GAUGE STRANDED, 2-CONDUCTOR LOW VOLTAGE WIRE. CAN EXTEND AC TRANSFORMER UP TO 1,000 FT FROM THE GATE.

TURN THE CONTROL BOX OFF

ROUTE THE AC TRANSFORMER CABLE INTO THE CONTROL BOX (See note above)

- A. When wiring the AC Transformer you will need to insert the AC wires into the **18VAC TRSFMR SCREW TERMINALS** which are located on the PWR INPUT section of the main control board. Once inserted then tighten each screw so that the wires do not come loose and fall out. The transformer is not polarity sensitive so either wire can go to either transformer terminal.

DO NOT PLUG IN THE TRANSFORMER DURING THIS STEP.

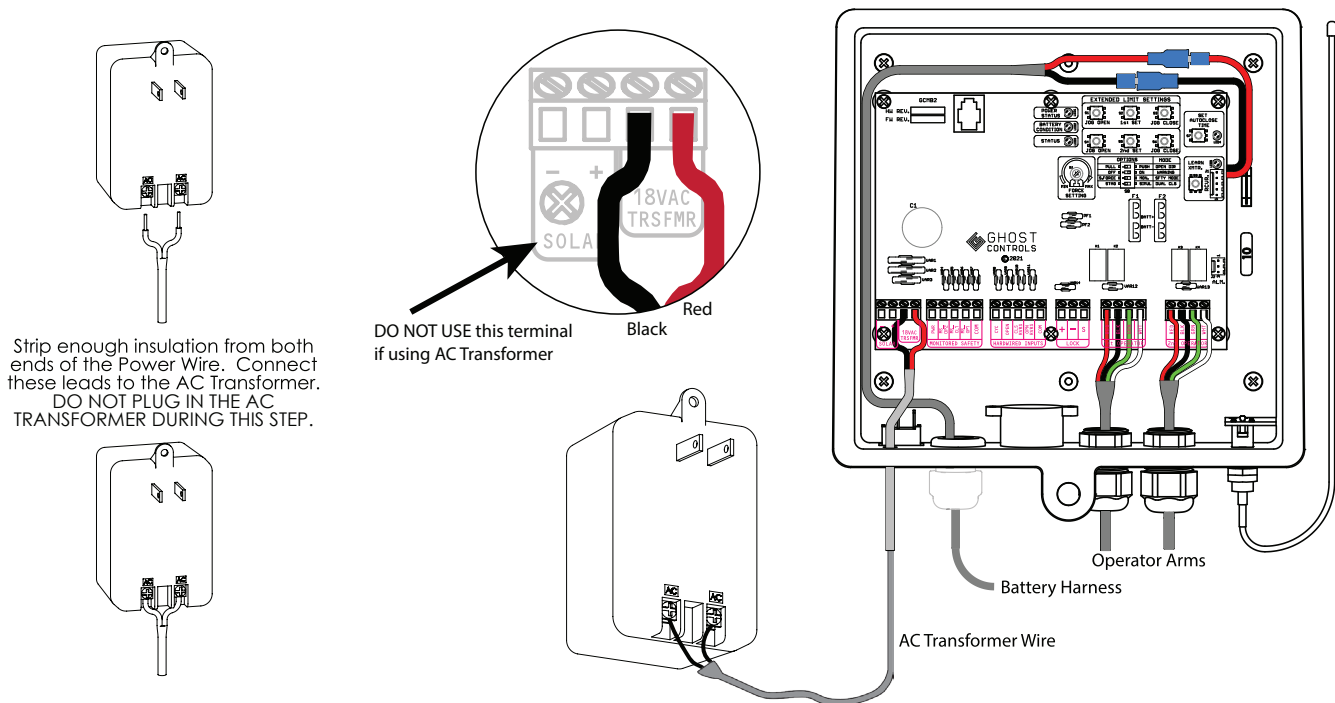

- B. Plug in the AC Transformer to outdoor outlet. Make sure you connect AC Transformer wires to control board prior to plugging in AC Transformer into weatherproof outdoor outlet.
- C. Turn the system on. Check that green LED (Power status) on top center of control board is on. This indicates that power is present for charging.



CONNECTING A 10W OR 30W SOLAR PANEL

TURN THE CONTROL BOX OFF

ADDING SOLAR PANEL WIRES TO CONTROL BOX

- A. When wiring a Solar Panel you will need to insert the solar wires into the **SOLAR SCREW TERMINALS** which are located on the PWR INPUT section of the main control board. Once inserted then tighten each screw so that the wires do not come loose and fall out. Please refer to diagram below. **DO NOT CONNECT AC TRANSFORMER IF USING SOLAR POWER.**

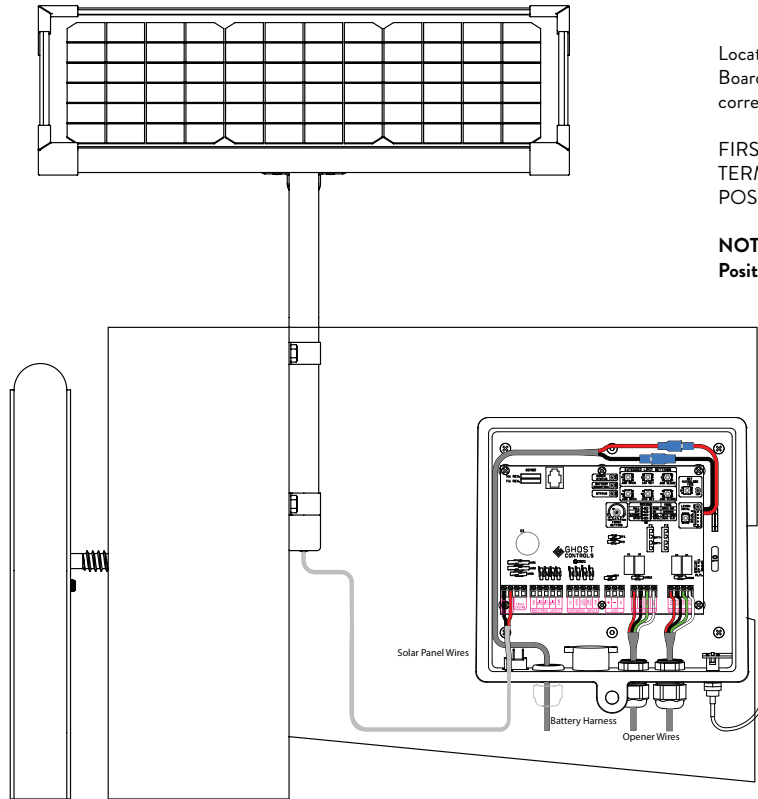

Locate the "SOLAR TERMINALS" on the Control Board and connect the solar panel wires to the correct terminals.

FIRST connect the BLACK wire to the NEGATIVE TERMINAL (-) and then the RED wire to the POSITIVE TERMINAL (+).

NOTE:
Positive (+) and Negative (-) polarity must be correct

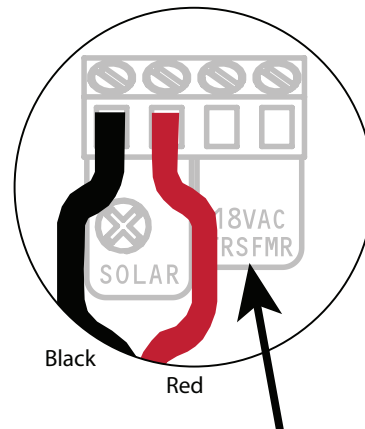

DO NOT USE this terminal if using Solar Panel

- B. Turn the system on. Check that green LED (Power status) on top center of control board is on. This LED will typically be blinking letting you know the battery is charging from solar.



- C. Check the chart shown for number of cycles assuming 8 hours a day of direct sunlight for solar applications.

UP TO 3 (AXDP) 10-WATT SOLAR PANELS OR THE AX30 30-WATT SOLAR POWER CAN BE CONNECTED TO ANY GHOST CONTROLS SYSTEM CONTROL BOARD.

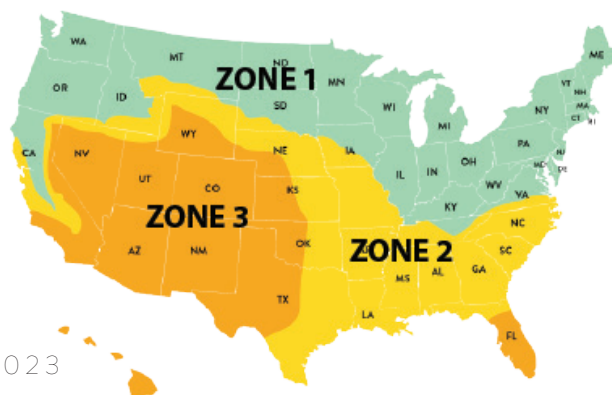

NUMBER OF 10W PANELS	ZONE 1	ZONE 2	ZONE 3
1=10W SINGLE	8 cycles	16 cycles	24 cycles
1=10W DUAL	4 cycles	8 cycles	12 cycles
2=20W SINGLE	14 cycles	28 cycles	38 cycles
2=20W DUAL	7 cycles	14 cycles	19 cycles
3=30W SINGLE	20 cycles	30 cycles	40 cycles
3=30W DUAL	10 cycles	15 cycles	20 cycles

SETTING AUTOCLOSE TIME ON YOUR GATE

The **AUTOCLOSE TIME** setting determines how long the gate will remain open each time it operates before automatically closing. The **factory default setting is off** which requires the user to push either a remote transmitter button, keypad code, or push-button to close the gate.

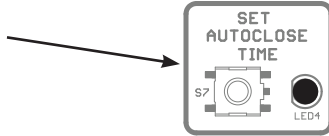

NOTE

The AUTOCLOSE time period begins once the gate has reached its open limit.

Minimum AUTOCLOSE Time Period	Maximum AUTOCLOSE Time Period
6 Seconds	60 Minutes. If longer time is needed, you should enable PartyMode or Disable AUTOCLOSE.

- A. Press and hold the **SET AUTOCLOSE TIME** button until it beeps.

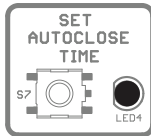

- B. Release the button and start counting the blinks or watching a clock until the desired AUTOCLOSE time has been reached. (the led will blink once a second)
- C. Once the desired amount of time has been reached press and release the **SET AUTOCLOSE TIME** button. The alarm will sound letting you know the Autoclose time took. AUTOCLOSE time can be set from 6 seconds to 60 minutes.



- D. The AUTOCLOSE feature is now enabled.

CANCELLING AUTOCLOSE TIME ON YOUR GATE

NOTE

Canceling AUTOCLOSE can only be performed when the gate opener is idle.

Cancelling AUTOCLOSE will remove your previous duration setting and force you to pick a new duration the next time you enable AUTOCLOSE. You can use PartyMode® to temporarily disable AUTOCLOSE and the system will retain your current AUTOCLOSE duration when PartyMode® is disabled. Turning the control board off will not remove AUTOCLOSE because turning the system back on will automatically reengage the AUTOCLOSE feature.

- A. Press and hold the **SET AUTOCLOSE TIME** button until it beeps.

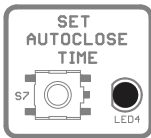

- B. Release the **SET AUTOCLOSE TIME** button. The LED next to the AUTOCLOSE button will start blinking at the rate of 1 blink per second
- C. Within 5 seconds, press and hold the **SET AUTOCLOSE TIME** button, you will hear a single beep indicating the feature has been disabled.

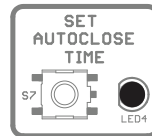

- D. The AUTOCLOSE feature is now disabled until you enable it with a new setting. IF THE AUTOCLOSE LED IS STILL ON, THE AUTOCLOSE HAS NOT BEEN DISABLED (REPEAT STEPS A-B-C).

AUTOCLOSE LED INDICATOR

The AUTOCLOSE LED indicates which mode the gate system controller is currently in. Note, that this LED will turn OFF after one minute of inactivity to conserve system power.

LED Solid On	LED Blinking On & Off	LED Off
AUTOCLOSE is enabled	AUTOCLOSE is enabled but temporarily suspended because PartyMode has been activated. Disabling PartyMode will turn the LED back to a Solid On.	AUTOCLOSE is disabled. AUTOCLOSE LED has timed out due to inactivity.

PUSH TO OPEN INSTALLATION

OPERATOR ARM INSTALLATION

*Your Ghost Opener Arm might look different than illustrations through this manual

Gate Operator System View Looking Straight Down from Above

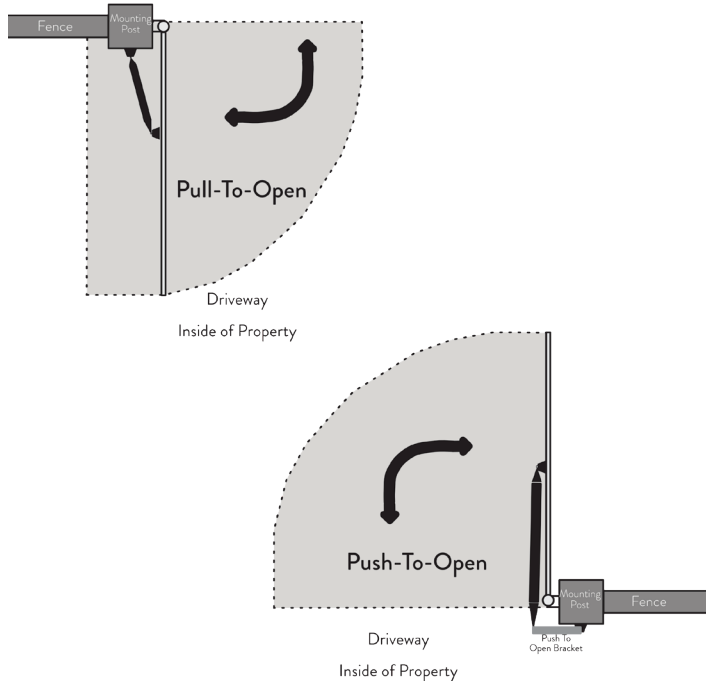

NOTE

Wheels cannot be used with any Ghost Controls® gate opener system!

For gates weighing over 200 lbs. ball bearing hinges are recommended.

Operator is not for use on solid panel privacy gates.

PUSH-TO-OPEN: GATE SWINGS TO OPEN OUTSIDE PROPERTY

The dimensions and step-by-step instructions that follow are for mounting the GHOST CONTROLS® Gate Operator PUSH-TO-OPEN installation system to a standard gate that swings away from your property. **You will need to make sure you purchase the Push-To-Open Bracket Kit (AXPO) before you start installing.**

FOR PULL-TO-OPEN APPLICATIONS, PLEASE SEE PULL-TO-OPEN APPLICATION ON “PULL TO OPEN INSTALLATION” ON PAGE 21.

STEP 1. Establish and mark the horizontal center lines of the gate and the post for proper alignment of gate brackets.

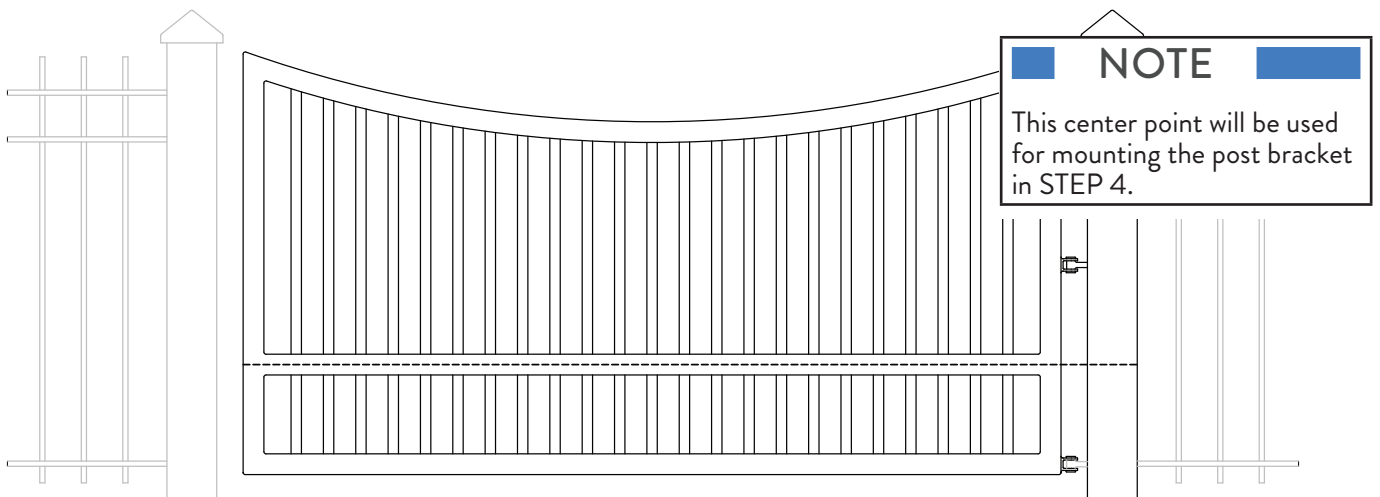

NOTE

This center point will be used for mounting the post bracket in STEP 4.

STEP 2. Post bracket pre-assembly.

YOU WILL NEED TO MAKE SURE YOU PURCHASE THE PUSH-TO-OPEN BRACKET KIT (AXPO) BEFORE YOU START THIS STEP

Insert the M10x1.5x75mm bolt and M10 washer through the hole that is closest to the post on the post bracket. Bolt should then go through first push-to-open bracket, pivot spacer, second push-to-open bracket, and exit bottom hole of post bracket as shown. Fasten a M10 washer and M10 locknut on the end of the bolt.

DO NOT overtighten the nuts because the Push-To-Open brackets may need to be adjusted later.

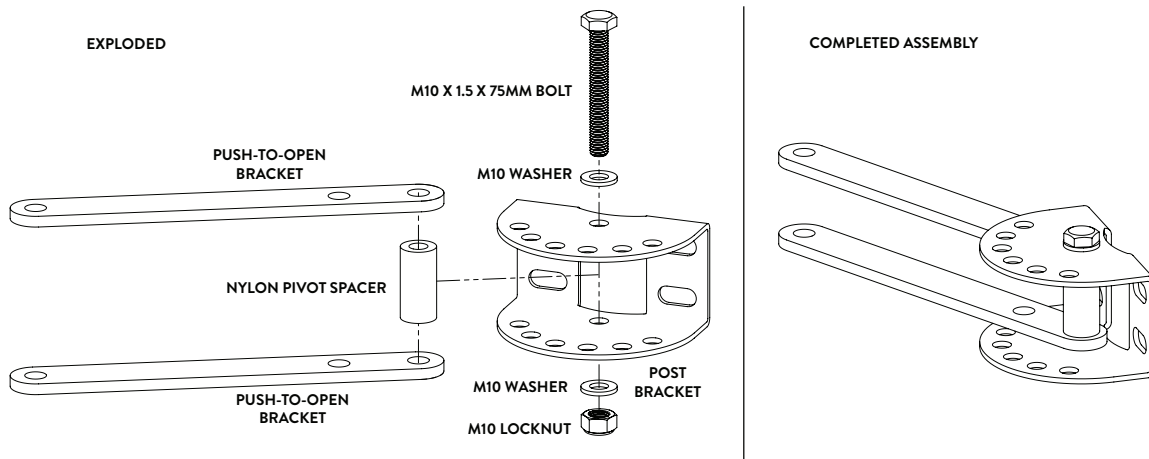
**STEP 3.** Clamp post bracket to post for alignment.

After the post bracket is pre-assembled and the horizontal centerline has been marked on the post as referred to in STEP 2 and 3, proceed to **CLAMP THE POST BRACKET TO THE MARKED CENTER LINE (CL)** on the post.

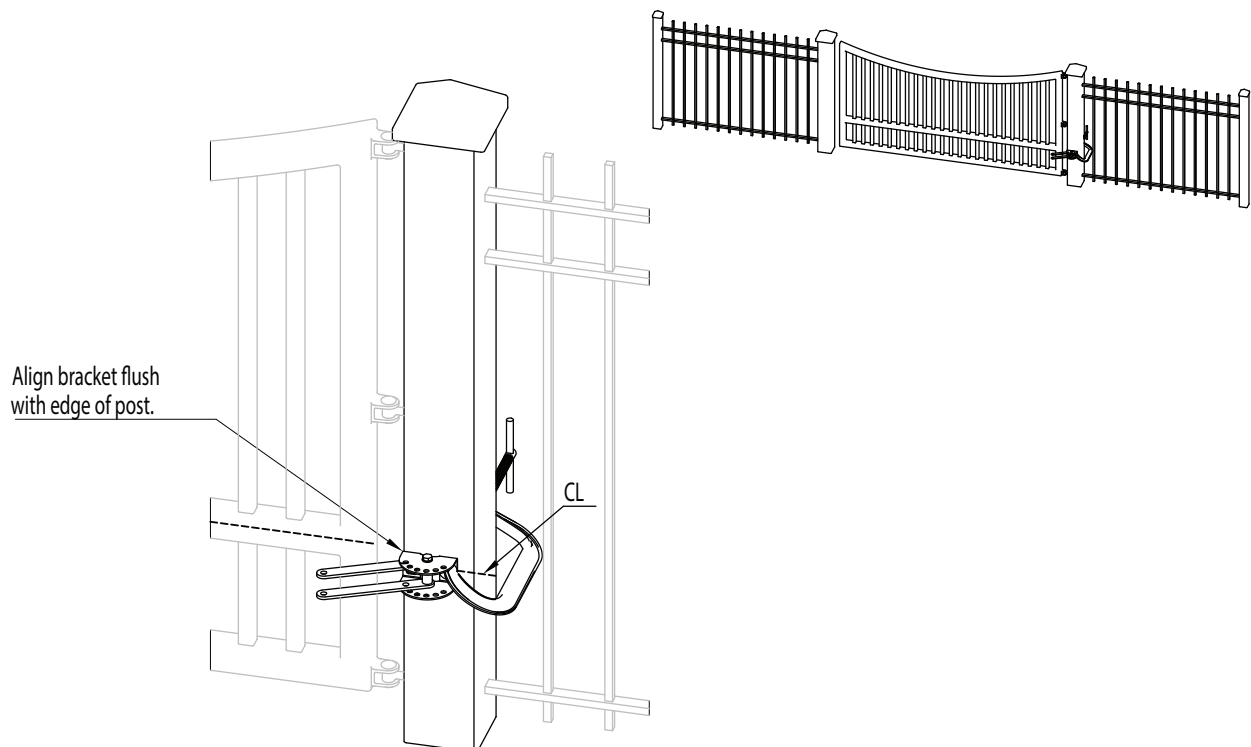

NOTE

For round wooden post installations we recommend notching the wooden post for proper installation of the post bracket. Follow the diagram below for proper notching of a round post.

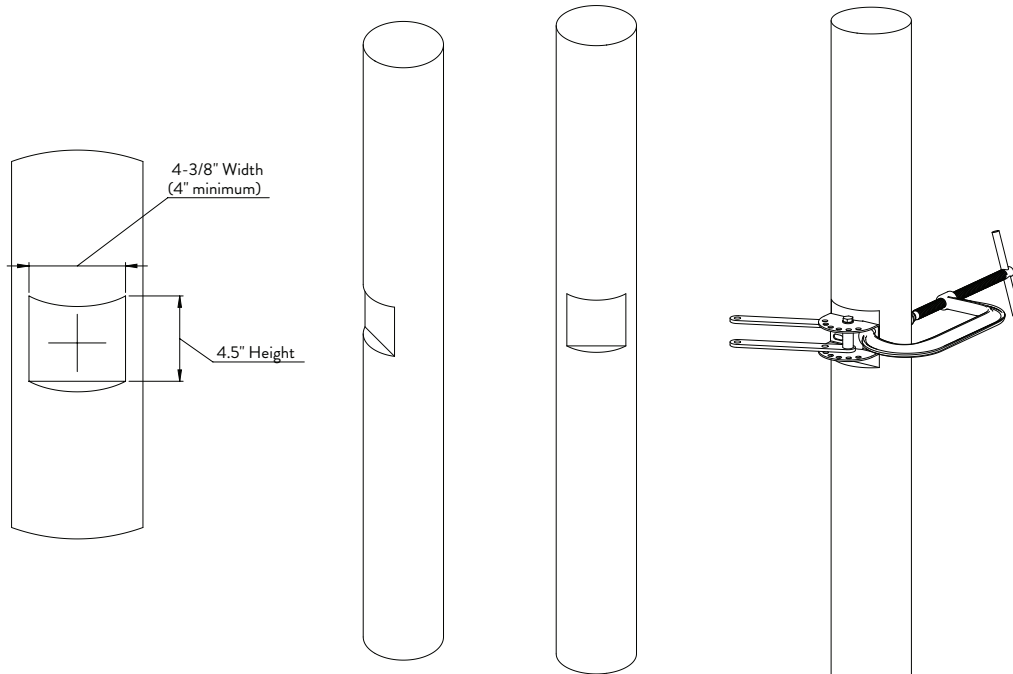

NOTE

For 3" and 4" round steel posts, we offer the **AX3R AND AX4R** round post adapter accessories (sold separately). See illustration using the round post adapter below.

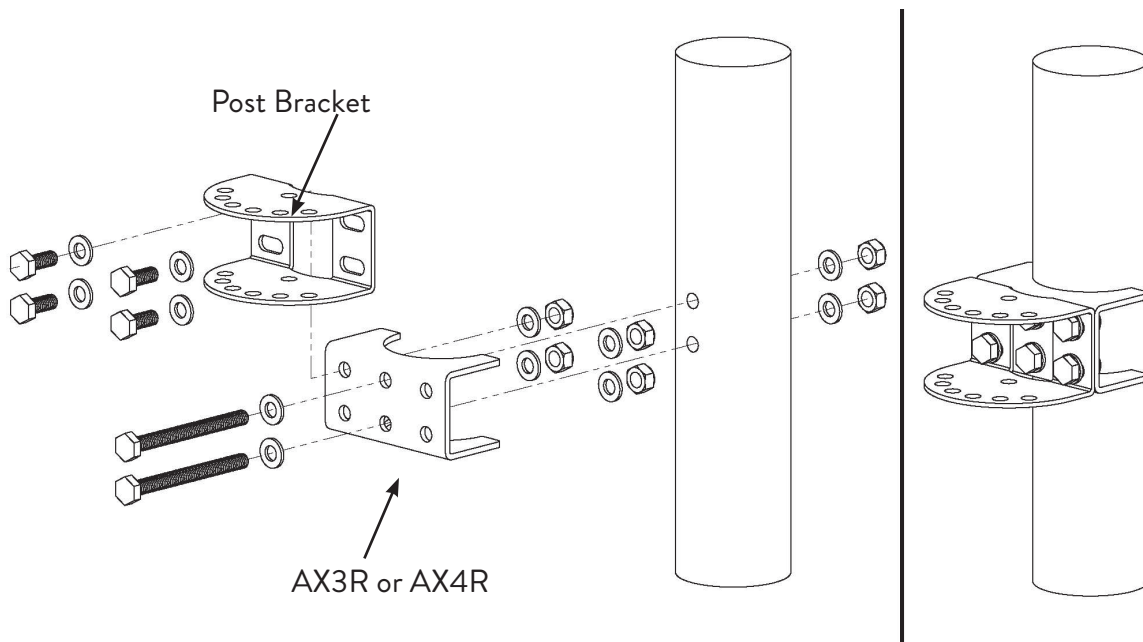

STEP 4. Verifying minimum of 4" gate clearance and finishing rear post mount bracket assembly. **If the clearance is less than 4", you will need to adjust the pivot brackets so that you have at least 4" of clearance, otherwise, you will not have minimal mechanical advantage needed to move the gate.**

Once the clearances are correct, **place the secondary bolt into the post mount and push-to-open brackets, as shown below.**

Insert the M10x1.5x75mm bolt and M10 washer through the post bracket hole, then first push-to-open bracket, pivot spacer, second push-to-open bracket, and exit out bottom hole of post bracket as shown below. Fasten a M10 washer and M10 locknut on the end of the bolt. **Finish by tightening both bolts on post bracket.**

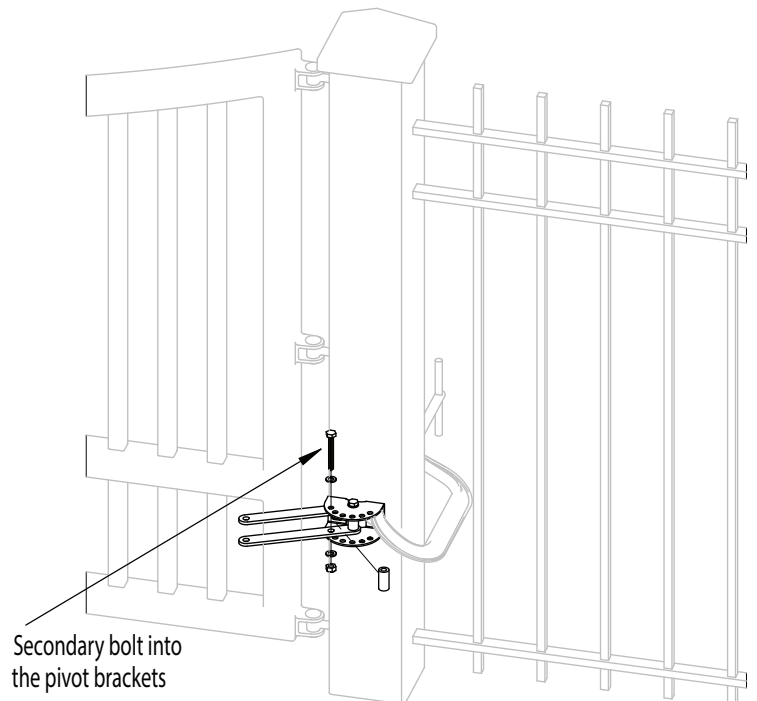
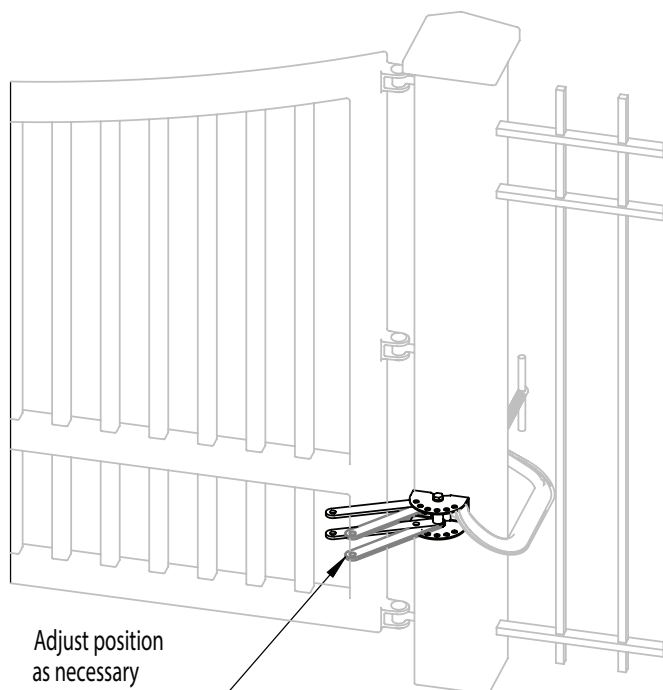
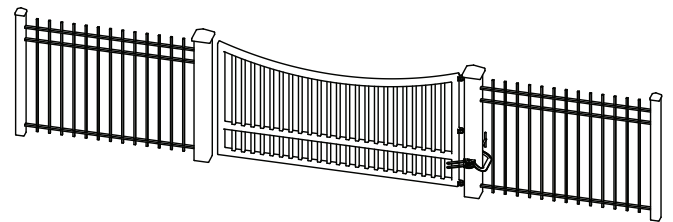
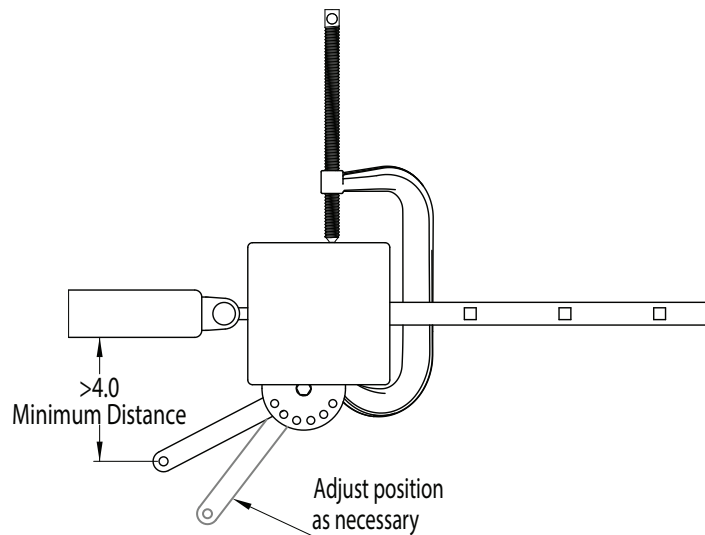

STEP 5. Drilling rear post bracket holes and bolting.

- A. With the post bracket still clamped to post, mark the center of the bracket slots. Remove the bracket.
- B. You will need a 7/16" drill bit and drill the (4) holes to mount the rear post bracket to the post.

TIP: Drill each hole one at a time and insert a bolt through to ensure that the holes are large enough and all aligned.

- C. Insert (1) M-10-175mm bolt, and (1) flat washer through the rear post bracket hole on the post and secure on backside with (1) flat washer and (1) M10 locknut as shown and loosely tighten to secure the rear bracket to the post. Repeat this 3 more times for the other bolts. Once all 4 bolts are in place, with the bracket aligned with the bolts in the center of the slots, firmly tighten all four bolts.

NOTE: Certain applications may require the use of different hardware (not included)

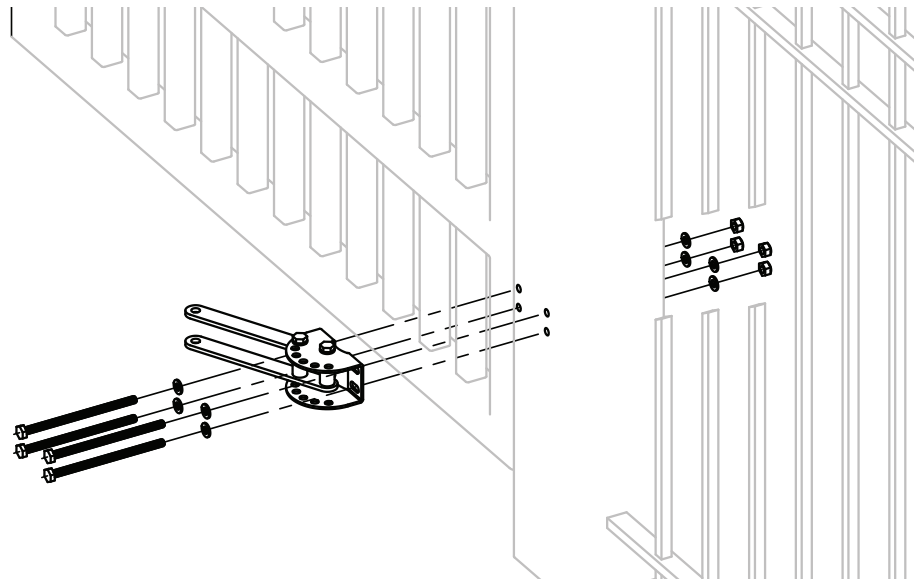

STEP 6. Install rear of operator on rear post mount.

Insert clevis pin, nylon spacer, and clevis hairpin as shown below to secure the rear of the operator to the post.

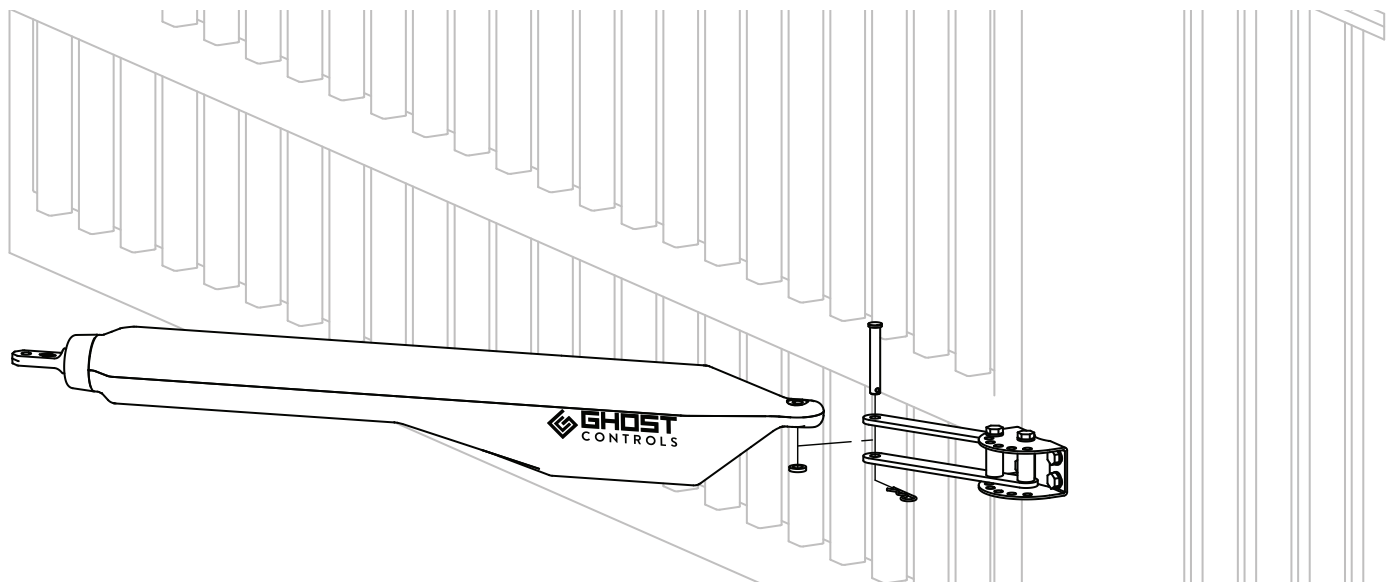

*Your Ghost Opener Arm might look different than illustrations through this manual

©Ghost Controls® 2023

INSTALLING THE CONTROL BOX AND *BATTERY BOX TO YOUR PULL-TO-OPEN SYSTEM

(*Shown below using a BATTERY BOX KIT (ABBT2), NOT INCLUDED)

STEP 7. Determine the mounting location for the control box and *optional battery box. The battery and control box must be located within 4 feet of each other. Then install.

NOTE

Mount the control box a minimum of 3 feet above the ground to keep dirt and water from damaging the control board and within 4 feet of the operator arm in order for the operator cable to reach the control box.

- A. Pre-drill (4) holes (7/32" drill bit) in backside of control and optional battery box, and through the fencing where you will be securing the control box and battery box.
- B. Now use the (4) supplied phillips screws for each box to mount the control box and optional battery box to the fence.

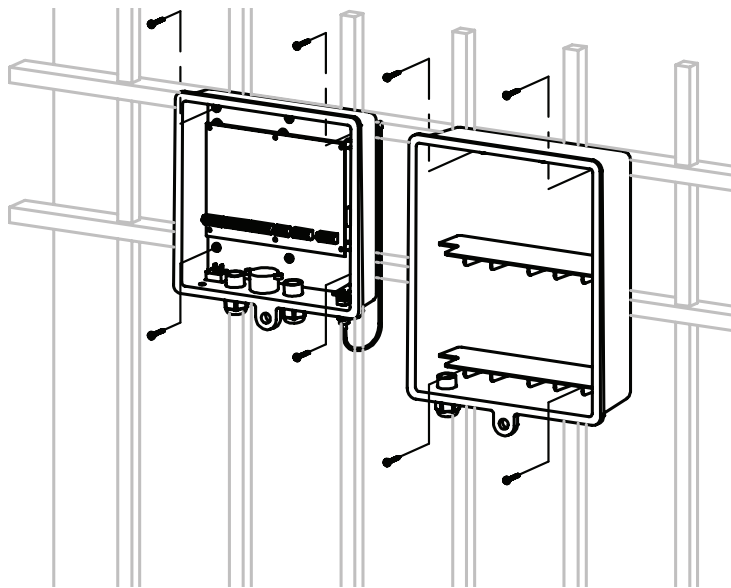

- C. Make sure the on/off switch on the bottom of control box is in the off position.

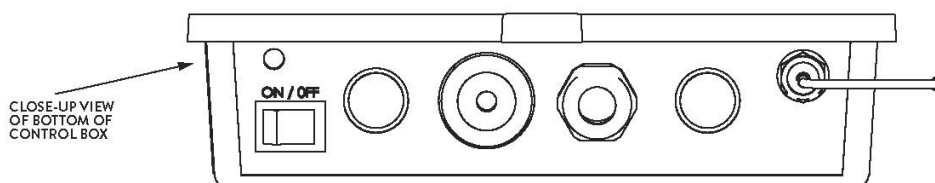

CONNECTING OPERATOR ARM TO CONTROL BOX

STEP 9. Insert the operator cables into the control box.

- A. Route the operator cable through the strain relief and into the control box.
- B. Connect the operator wires to the control board. Find the 1st operator screw terminal on control board and insert the red, black, green and white wires (left to right) into the matching color coded terminals and tighten each of the screws so that the wires do not come loose and fall out.
 - *FOR DUAL GATES: You will connect the second operator wires later into the 2nd operator screw terminal.
- C. Make sure wires are not inserted too far into the terminal slots and that the wire insulation is not interfering with contact to the system control board.
- D. Tighten strain relief nuts on the control box to close the seals around the wires.

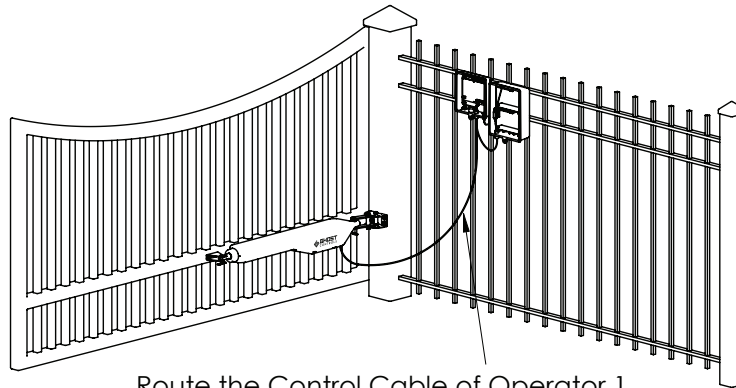

Route the Control Cable of Operator 1 through the strain relief of the Control Box.

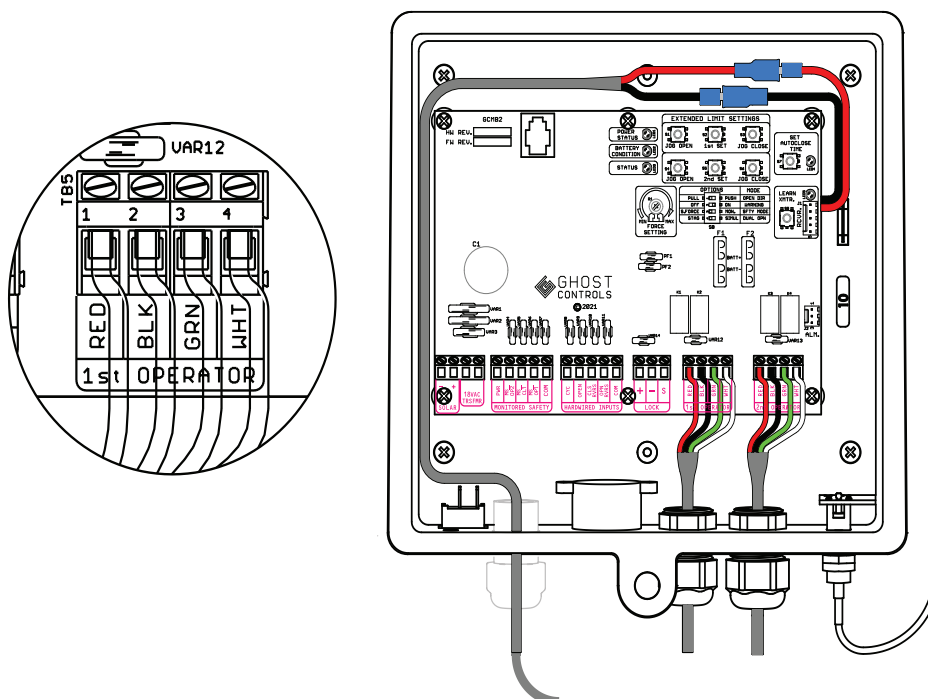

PREPARING THE GATE SYSTEM CONTROLLER

The gate system control board provides one convenient place to make all of your system connections and to change any settings that you desire to personalize how your automatic gate opener system operates at your home or property. This main board (shown below) is located inside of the control box of your system and will be referred to in detail through the next few sections. Because this control box may be mounted within reach of children or potential vandals, we recommend a padlock to securely lock this box in the closed position to prevent tampering. **NOTE: BEFORE PROCEEDING MAKE SURE THE ON/OFF SWITCH ON BOTTOM OF CONTROL BOX IS IN THE OFF POSITION.**

NOTE: Your control board may have minor differences than the control board shown.

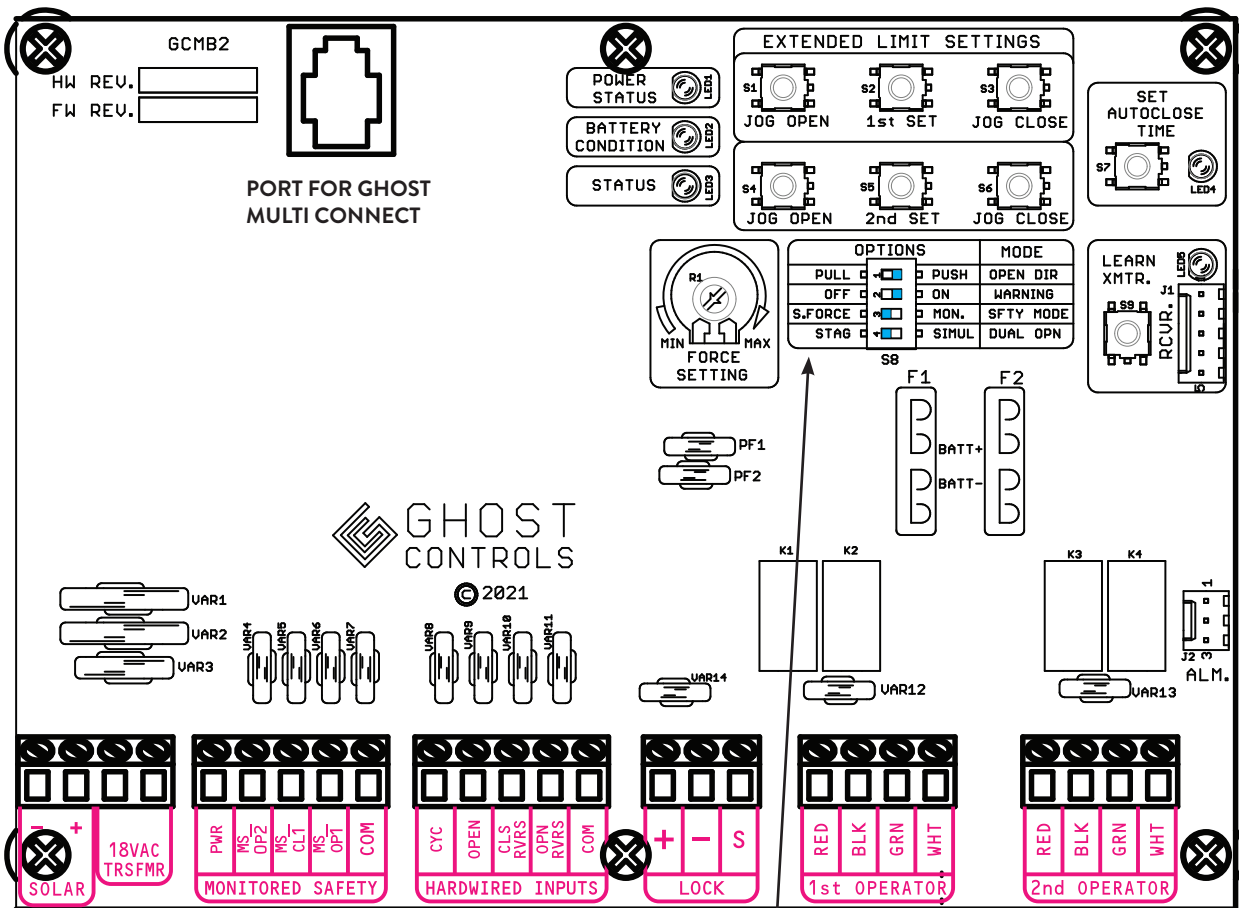

STEP 10. Check the system DIP switch settings verify that they are in the correct positions as shown.

DIP Switch #	OFF Position	ON Position
1	<input type="checkbox"/> Factory Default: Pull-To-Open	<input checked="" type="checkbox"/> Push-To-Open
2	<input type="checkbox"/> Warning Disabled	<input checked="" type="checkbox"/> Factory Default: Warning Enabled
3	<input checked="" type="checkbox"/> Factory Default: SafeForce® Mode	<input type="checkbox"/> Monitored External Safety Devices Mode
4	<input checked="" type="checkbox"/> Factory Default: Delay Open 2nd Arm	<input type="checkbox"/> Simultaneous Open

DIP SWITCH OPTION SETTINGS. There are four DIP Switches located on the main control board (shown) that must be positioned properly for your particular installation.

OPTIONS		MODE	
PULL		PUSH	OPEN DIR
OFF		ON	WARNING
S.FORCE		MON.	SFTY MODE
STAG		SIMUL	DUAL OPN

A. DIP #1 OPEN DIRECTION. The opening direction of the gate operator is determined by DIP#1.

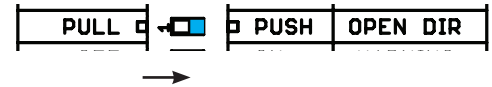

DIP Switch #	OFF Position	ON Position
1	Pull-To-Open (Factory Default): Gate is pulled to open into your property.	Push-To-Open Installation: Gate is pushed to open away from your property.

B. DIP #2 ALARM WARNING. The warning alarm is determined by DIP#2.

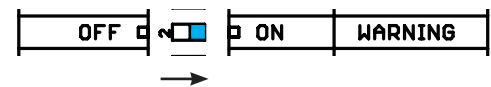

DIP Switch #	OFF Position	ON Position
2	Warning Disabled: AUTOCLOSE and initial gate movement alarm warning is disabled. This does not disable the alarm warning for consecutive obstruction as required by UL325 safety standard.	Warning Enabled (Factory Default): AUTOCLOSE and initial gate movement warning is enabled.

C. DIP #3 MONITORED SAFETY DEVICES. Keep Switch To The Left (Factory Setting) Unless Using Monitored External Safety Devices Then Switch To The Right.



YOUR SYSTEM WILL NOT WORK IF SAFTEY MODE IS ON AND YOU DO NOT HAVE MONITORED EXTERNAL SAFETY DEVICES CONNECTED.

DIP Switch #	OFF Position (FACTORYSETTING)	ON Position
3	Patent-pending SafeForce® Mode (Factory Default): Force output is limited to ensure safe operation as specified by Type C in UL325 requirement.	Monitored Safety Mode: Monitored safety devices required / Compatible GHOST CONTROLS® safety devices only. Monitored safety devices must be present and operate properly as specified by Type B1 or B2 in UL325 requirement. See monitored safety device connection in the monitored photo eye instructions manual for more details.

D. DIP #4 DUAL (BI-PARTING) GATE OPENING SEQUENCE. The gate opening sequence for dual gate opener systems only is determined by DIP#4. **The SECOND arm will always CLOSE first before the FIRST arm.**

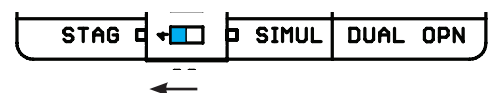

DIP Switch #	OFF Position (FACTORY SETTING)	ON Position
4	Delay Open (Factory Default): FIRST arm will open before the SECOND arm.	Simultaneous Open: Both the FIRST arm and the SECOND arm will simultaneously OPEN. If Gate Lock is installed, the system will ignore this DIP switch setting and default to delay open on the SECOND arm.

TURN CONTROL BOX ON. YOU SHOULD HEAR A SERIES OF BEEPS AS THE SYSTEM IS TURNED ON

STEP 11. Locate the jog buttons at the top right of control box to test the arm and connections. Press the jog open button to extend the arm 3-4 inches out.

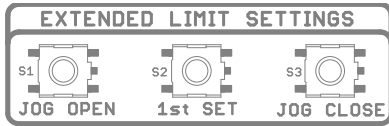

USE FOR FIRST ARM INSTALLATION

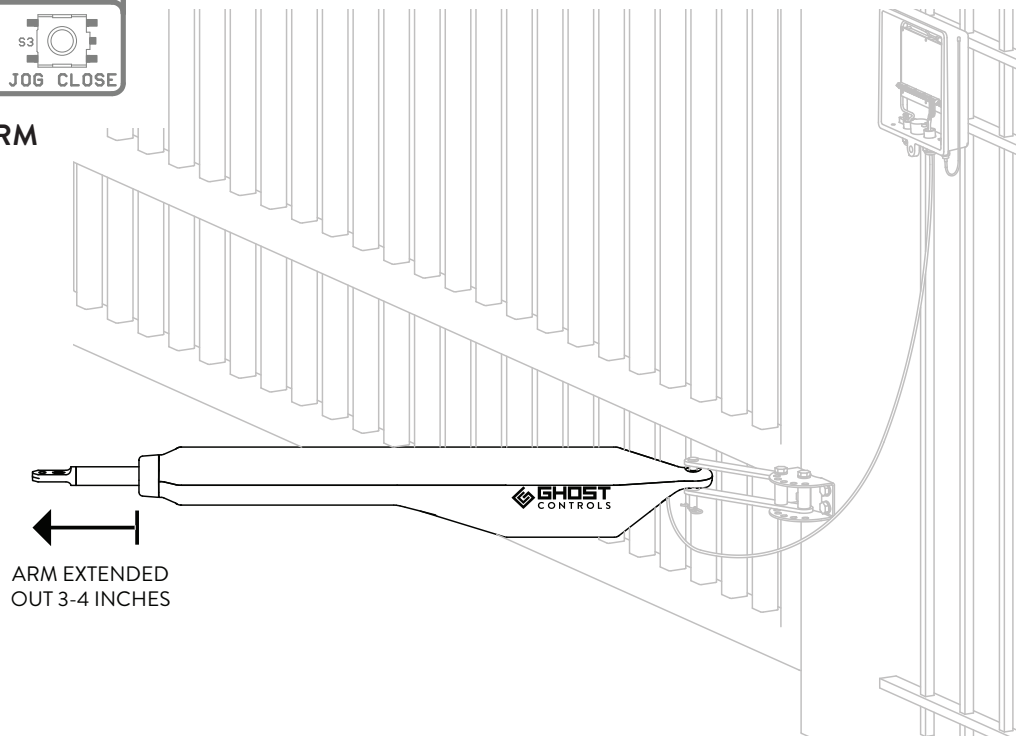

ARM EXTENDED OUT 3-4 INCHES

STEP 12. Use the remote transmitter that came in your kit and press first button to fully retract the arm. The arm will stop on its own.

The arm in the fully retracted position will determine the **CLOSED** position of the gate.

NOTE

The arm has an internal limit switch that is fixed and is not adjustable.

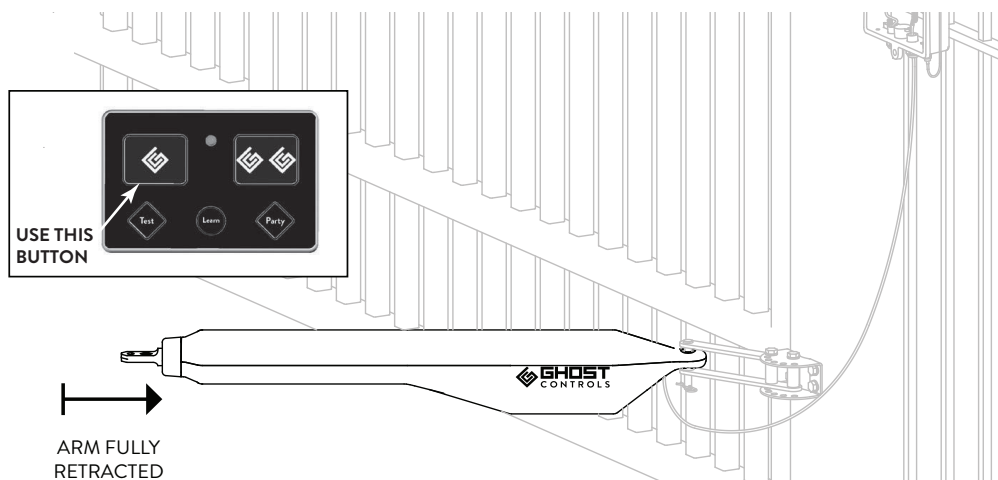

ARM FULLY RETRACTED

*Your Ghost Opener Arm might look different than illustrations throughout this manual

WARNING

DO NOT SCREW THE OPERATOR ARM IN OR OUT TO ADJUST YOUR GATE POSITION. DOING SO CAUSES THE SYSTEM TO NOT FUNCTION PROPERLY.

TURN THE CONTROL BOX OFF

STEP 13. Attach front mount bracket to the operator. The gate must remain in the desired closed position.

CLOSE THE GATE TO THE DESIRED CLOSED POSITION

- A. Temporarily assemble the front mount of the gate by inserting the supplied 10mm x 40mm clevis pin, 10mm I.D. nylon spacer, and clevis hairpin through the gate bracket.

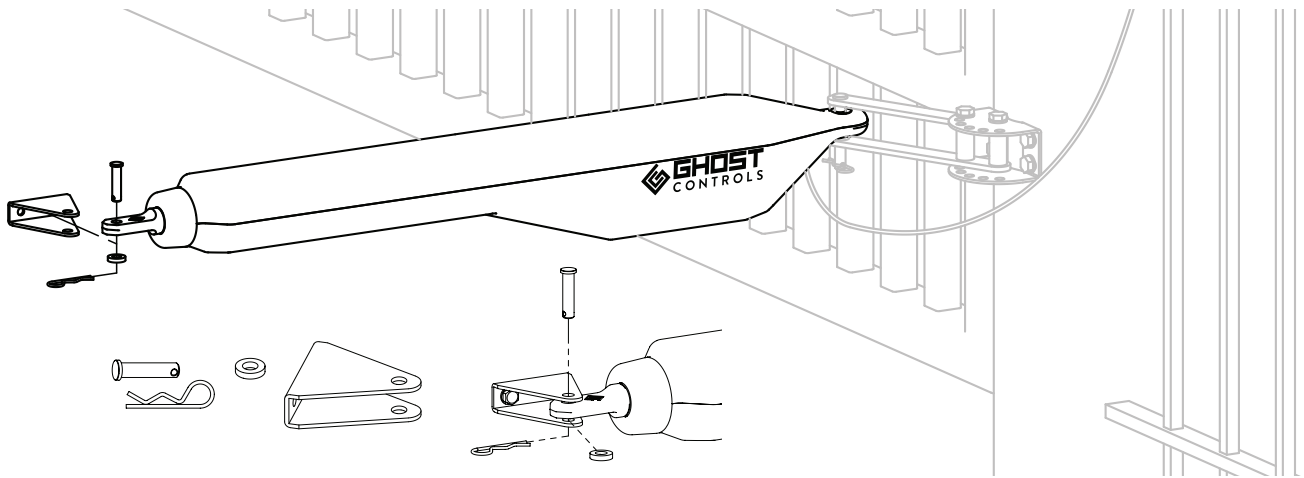

*Your Ghost Opener Arm might look different than illustrations throughout this manual

NOTE

ALTERNATE TUBE GATE BRACKETS FOR MOUNTING TUBULAR GATES. (NOT FOR USE WITH FLAT PANEL GATES) see below image. Tube brackets (AXTB) sold separately.

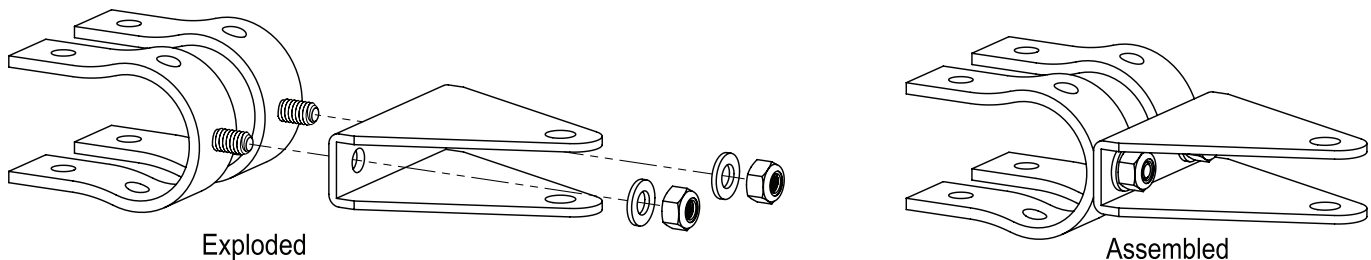

STEP 14. Mounting the **FRONT MOUNT AND ESTATE BRACKET** to gate. The gate must remain in the desired closed position

CLOSE THE GATE TO THE DESIRED CLOSED POSITION

(this will be the position that your gate will always close to)

- A. Line up the pre-assembled front mount gate bracket over the center-most bar on your gate and **mark the center location of the outermost hole on the gate.**

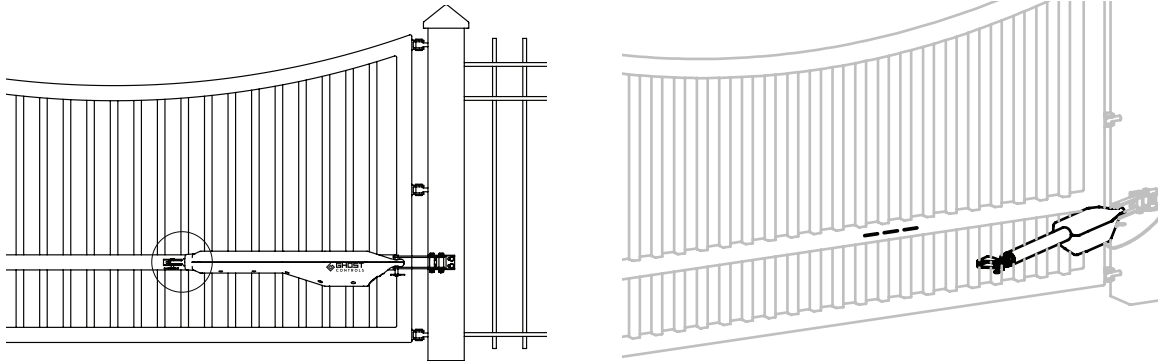

NOTE

DO NOT SCREW THE OPERATOR ARM IN OR OUT TO ADJUST YOUR GATE POSITION. DOING SO CAUSES THE SYSTEM TO NOT FUNCTION PROPERLY.

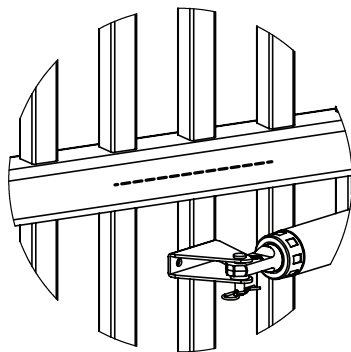

Mark center location of outermost hole

Center-punch location for drilling outermost hole

Drill hole

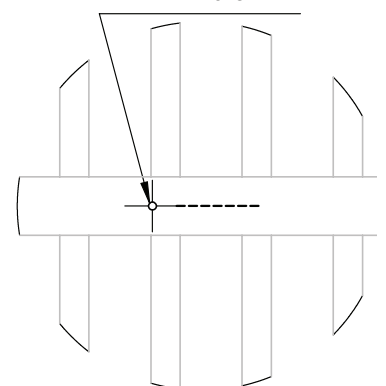
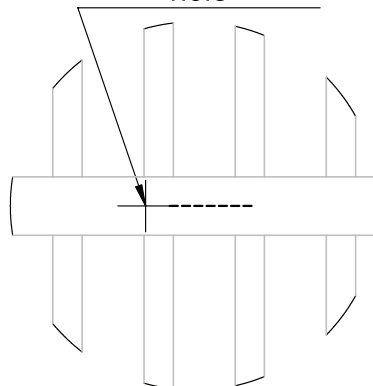
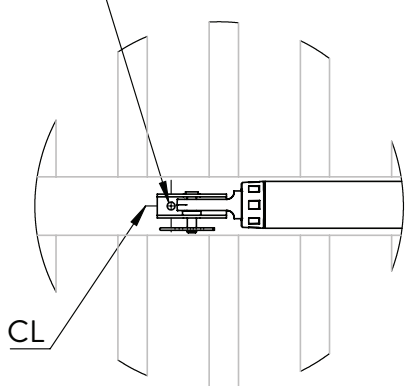

- B. Install the front mount gate bracket and estate bracket** on the gate by aligning the outermost hole and inserting (1) M8 x 65mm flat washer, and (1) M8 nylon locknut through gate and front mount bracket, as show below. Tighten to secure the brackets to the gate.

MAKE SURE GATE IS STILL IN CLOSED POSITION (arm must be fully retracted).

Estate Bracket install
on backside of gate

Front Mount Bracket

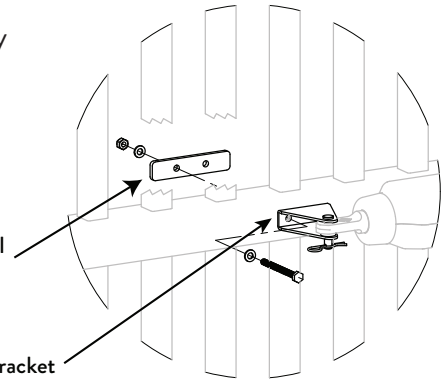

- C. Disconnect operator from gate bracket and swing away from the gate.**

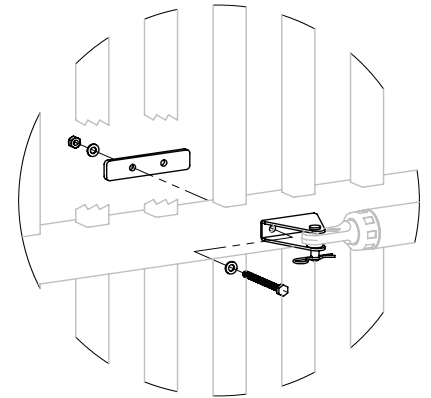

- D. Assemble clevis pin, front spacer and hair pin to operator to prevent loss.**

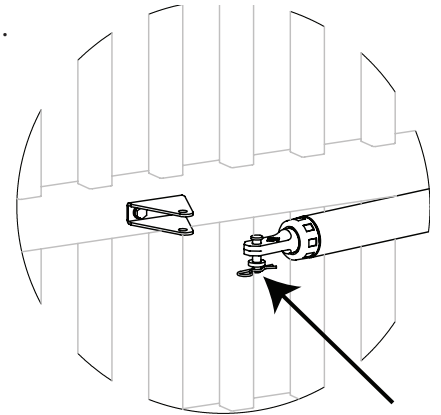

- E. Now you can mark and drill the inner most hole on the front mount bracket, shown below.**

NOTE: It might be necessary to remove the bracket to drill hole

Mark and drill
center location of
innermost hole

CL

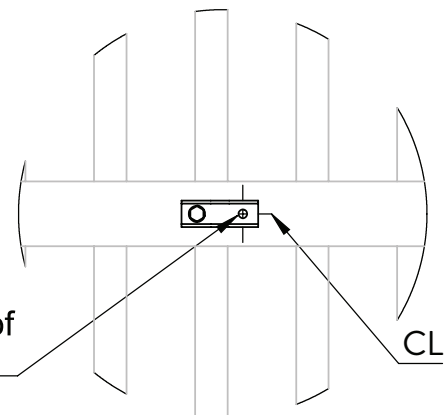

- F. Align the innermost hole of the estate and front mount brackets and insert (1) M8 x 65mm flat washer, and (1) M8 nylon locknut through both holes and tighten to secure the bracket to the gate. **YOUR FRONT MOUNT AND ESTATE BRACKET SHOULD NOW BE ATTACHED AND SECURED TO THE GATE.**

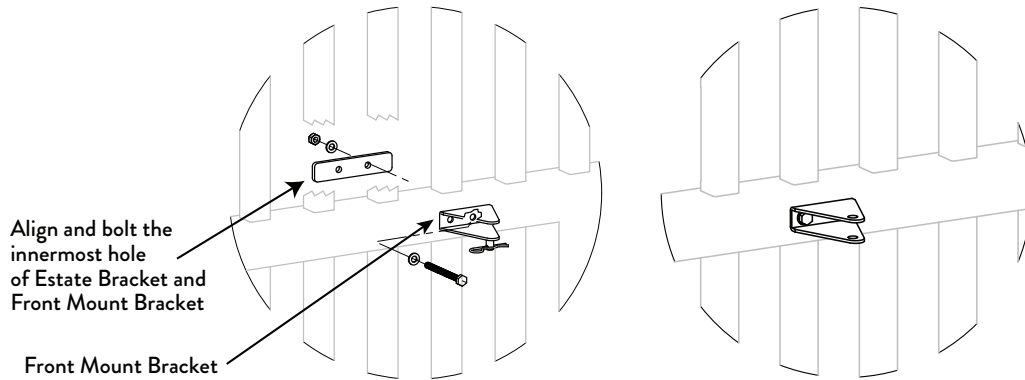

- G. Align and attach arm of operator to the secured front mount bracket, as shown below. **Make sure all parts installed during installation are tightened down.**

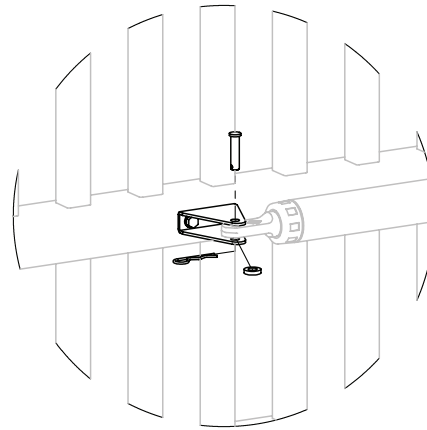

STEP 15. PROCEED TO PROGRAMMING THE OPEN LIMIT SETTING.

PROGRAMMING THE OPEN LIMIT: PUSH-TO-OPEN

The *OPEN* limit is when the operator is extended and the gate is in the *OPEN* position.

IMPORTANT

ONLY THE OPERATOR ARMS' EXTENDED LIMIT IS ADJUSTABLE AND CAN BE SET WITH THE CONTROL BOARD. THE ARMS' RETRACTED POSITION IS FIXED AND IS NOT ELECTRONICALLY ADJUSTABLE.

THE CLOSED POSITION IS SET BY HARDWARE MOUNTING ONLY. Please refer to the hardware installation to make sure the retracted position is properly set/installed.

Installation Type	Retracted Position	Extended Position
Push-To-Open	Gate at the fully <i>CLOSED</i> position (not electronically adjustable)	Gate at the <i>OPEN</i> position (electronically adjustable)

TURN THE CONTROL BOX ON

SETTING THE OPEN LIMIT

- Locate the **1st extended limit settings** on the control board and press and hold the **JOG OPEN** button for the 1st gate until the gate reaches the **desired OPEN position**. The gate can move only if pressure is maintained. Releasing the **JOG** button will stop the gate immediately.
- Both **JOG OPEN** or **JOG CLOSE** buttons are needed to 'fine' tune your **desired OPEN position**.
- Press and hold the 1st set limit button on the control panel until it beeps, then release. Then Press and hold the 2nd set limit button until it beeps, then release

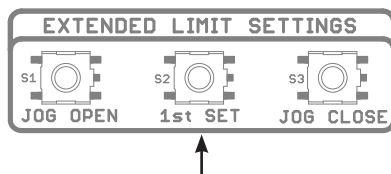
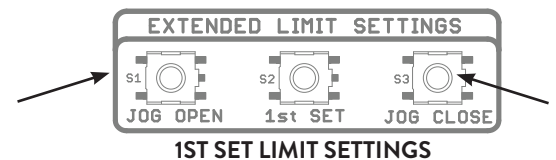

- Press the transmitter button to activate the gates and let the gate close fully you should hear a single beep.

When the gate reaches its **CLOSED** position, the control board will sound a single beep, confirming the **OPEN** limit has been set.

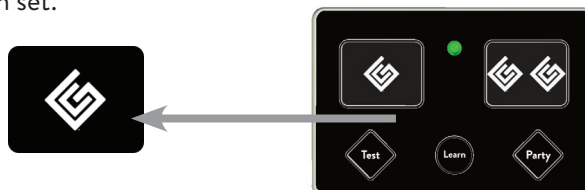

- Confirm the newly programmed **OPEN** limit by pressing the remote transmitter button to activate the gate and confirm the **OPEN** position has been set correctly. This limit is stored and remembered even when all of the power sources are removed.



- Repeat if needed to change your desired **OPEN** position.
- Test your system with the remote transmitter to make sure it opens and closes without errors.

CONNECTING THE AC TRANSFORMER

AC Transformer charges the system battery. System will not operate without a 12V battery installed and connected.

IMPORTANT
DO NOT USE THE AC TRANSFORMER AND SOLAR POWER AT THE SAME TIME!

NOTE
TO COMPLETE STEP 21 YOU WILL NEED 16 GAUGE STRANDED, 2-CONDUCTOR LOW VOLTAGE WIRE. CAN EXTEND AC TRANSFORMER UP TO 1,000 FT FROM THE GATE.

TURN THE CONTROL BOX OFF

ROUTE THE AC TRANSFORMER CABLE INTO THE CONTROL BOX (See note above)

- A. When wiring the AC Transformer you will need to insert the AC wires into the **18VAC TRSFMR SCREW TERMINALS** which are located on the PWR INPUT section of the main control board. Once inserted then tighten each screw so that the wires do not come loose and fall out. The transformer is not polarity sensitive so either wire can go to either transformer terminal.

DO NOT PLUG IN THE TRANSFORMER DURING THIS STEP.

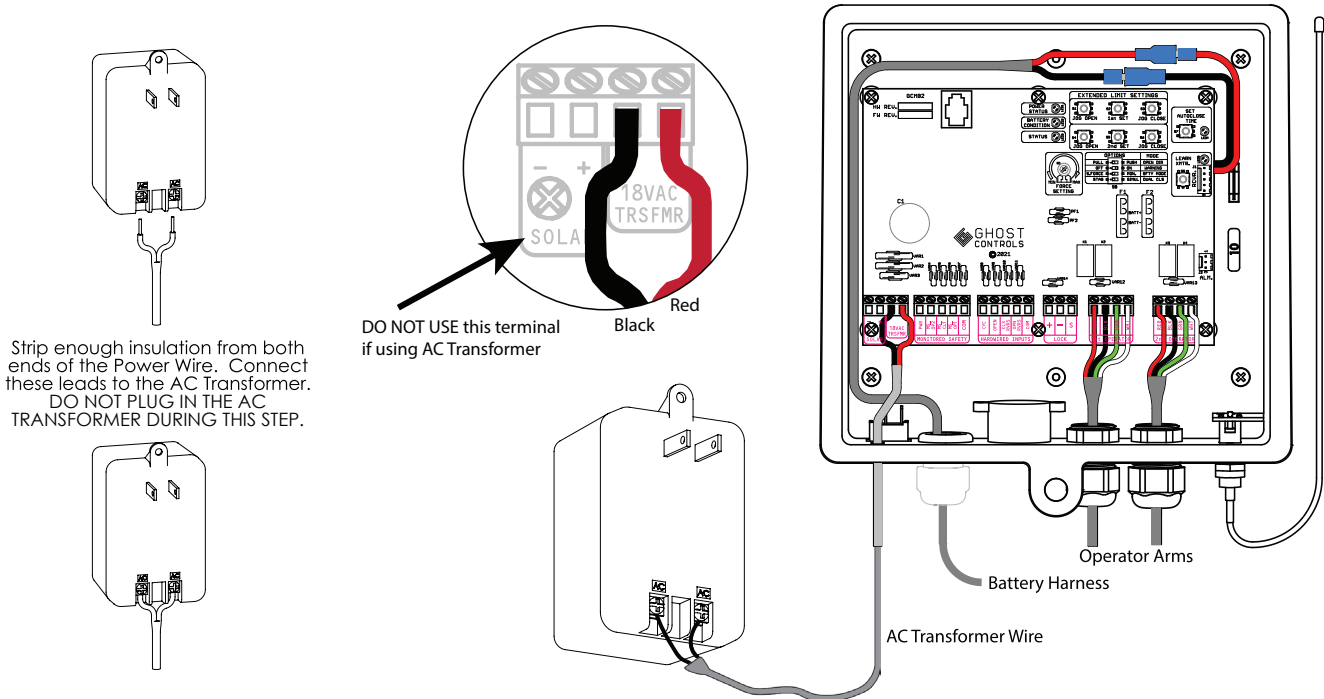

Strip enough insulation from both ends of the Power Wire. Connect these leads to the AC Transformer. **DO NOT PLUG IN THE AC TRANSFORMER DURING THIS STEP.**

- B. Plug in the AC Transformer to outdoor outlet. Make sure you connect AC Transformer wires to control board prior to plugging in AC Transformer into weatherproof outdoor outlet.
- C. Turn the system on. Check that green LED (Power status) on top center of control board is on. This indicates that power is present for charging.



CONNECTING A 10W OR 30W SOLAR PANEL

TURN THE CONTROL BOX OFF

ADDING SOLAR PANEL WIRES TO CONTROL BOX

- A. When wiring a Solar Panel you will need to insert the two solar wires into the **SOLAR SCREW TERMINALS** which are located on the PWR INPUT section of the main control board. Once inserted then tighten each screw so that the wires do not come loose and fall out. Please refer to diagram below. **DO NOT CONNECT AC TRANSFORMER IF USING SOLAR POWER.**

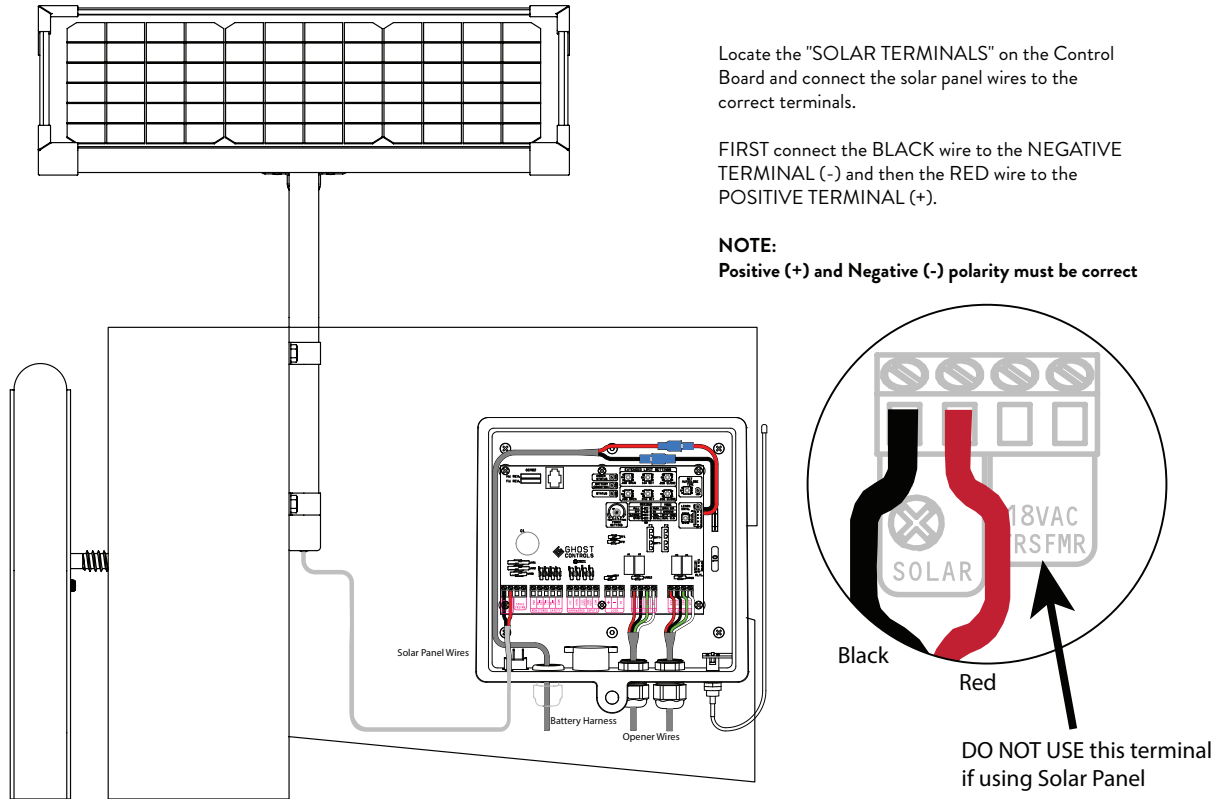

- B. Turn the system on. Check that green LED (Power status) on top center of control board is on. This LED will typically be blinking letting you know the battery is charging from solar.



- C. Check the chart shown for number of cycles assuming 8 hours a day of direct sunlight for solar applications.

UP TO 3 (AXDP) 10-WATT SOLAR PANELS OR THE AX30 30-WATT SOLAR POWER CAN BE CONNECTED TO ANY GHOST CONTROLS SYSTEM CONTROL BOARD.

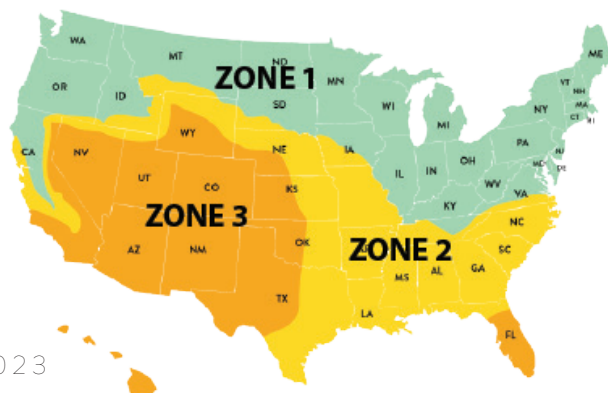

NUMBER OF 10W PANELS	ZONE 1	ZONE 2	ZONE 3
1=10W SINGLE	8 cycles	16 cycles	24 cycles
1=10W DUAL	4 cycles	8 cycles	12 cycles
2=20W SINGLE	14 cycles	28 cycles	38 cycles
2=20W DUAL	7 cycles	14 cycles	19 cycles
3=30W SINGLE	20 cycles	30 cycles	40 cycles
3=30W DUAL	10 cycles	15 cycles	20 cycles

SETTING AUTOCLOSE TIME ON YOUR GATE

The **AUTOCLOSE TIME** setting determines how long the gate will remain open each time it operates before automatically closing. The **factory default setting is off** which requires the user to push either a remote transmitter button, keypad code, or push-button to close the gate.

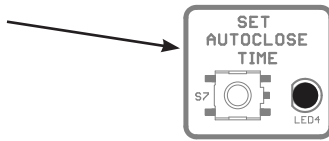

NOTE

The AUTOCLOSE time period begins once the gate has reached its open limit.

Minimum AUTOCLOSE Time Period	Maximum AUTOCLOSE Time Period
6 Seconds	60 Minutes. If longer time is needed, you should enable PartyMode or Disable AUTOCLOSE.

- A. Press and hold the **SET AUTOCLOSE TIME** button until it beeps.

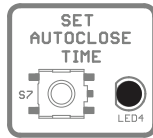

- B. Release the button and start counting the blinks or watching a clock until the desired AUTOCLOSE time has been reached. (the led will blink once a second)
- C. Once the desired amount of time has been reached press and release the **SET AUTOCLOSE TIME** button. The alarm will sound letting you know the Autoclose time took. AUTOCLOSE time can be set from 6 seconds to 60 minutes.

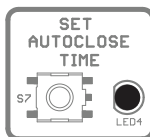

- D. The AUTOCLOSE feature is now enabled.

CANCELLING AUTOCLOSE TIME ON YOUR GATE

NOTE

Canceling AUTOCLOSE can only be performed when the gate opener is idle.

Cancelling AUTOCLOSE will remove your previous duration setting and force you to pick a new duration the next time you enable AUTOCLOSE. You can use PartyMode® to temporarily disable AUTOCLOSE and the system will retain your current AUTOCLOSE duration when PartyMode® is disabled. Turning the control board off will not remove AUTOCLOSE because turning the system back on will automatically reengage the AUTOCLOSE feature.

- A. Press and hold the **SET AUTOCLOSE TIME** button until it beeps.

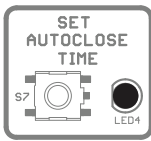

- B. Release the **SET AUTOCLOSE TIME** button. The LED next to the AUTOCLOSE button will start blinking at the rate of 1 blink per second
- C. Within 5 seconds, press and release the **SET AUTOCLOSE TIME** button, you will hear a single beep indicating the feature has been disabled.

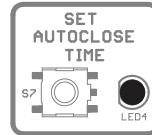

- D. The AUTOCLOSE feature is now disabled until you enable it with a new setting. IF THE AUTOCLOSE LED IS STILL ON, THE AUTOCLOSE HAS NOT BEEN DISABLED (REPEAT STEPS A-B-C.)

AUTOCLOSE LED INDICATOR

The AUTOCLOSE LED indicates which mode the gate system controller is currently in. Note, that this LED will turn OFF after one minute of inactivity to conserve system power.

LED Solid On	LED Blinking On & Off	LED Off
AUTOCLOSE is enabled	AUTOCLOSE is enabled but temporarily suspended because PartyMode has been activated. Disabling PartyMode will turn the LED back to a Solid On.	<ul style="list-style-type: none"> AUTOCLOSE disabled. AUTOCLOSE LED has timed out due to inactivity.

TROUBLESHOOTING GUIDE

For troubleshooting help visit:

<https://ghostcontrols.com/pages/technical-support>

For helpful videos visit:

<https://ghostcontrols.com/pages/installation-video>

LEARN NEW REMOTE

2021-09

DO NOT USE this procedure if you already have a remote that operates the gate and just want to add an additional remote. If you want to add an additional remote to your system, please refer to the remote manual or ghostcontrols.com.

1. Press and hold the 'LEARN XMTR'  until the alarm sounds and the yellow LED stays ON. Release the button.
2. Press and hold the desired remote button on the transmitter (within 10 seconds) until the alarm sounds or the gate is moving. The new remote is now learned.

AUTOCLOSE

When enabled, gate will automatically close after the set time. This feature will only be active when gate is at the fully open position.

Enable and Set AutoClose Time:

1. Press and hold 'SET AUTOCLOSE TIME' push button  until the alarm sounds and the **GREEN** LED stays lit.
2. Release the button. The GREEN LED will start blinking at the rate of 1 blink per second.
3. Count the desired time for AUTOCLOSE (Range: 6 seconds to 60 minutes) using the **GREEN** LED.
4. Press and release the "SET AUTOCLOSE TIME" button again when the desired time is reached.
5. If AUTOCLOSE is enabled, the GREEN LED will remain ON.

Disable AutoClose:

1. Press and hold "SET AUTOCLOSE TIME" push button  until the alarm sounds and the **GREEN** LED stays On. Release the button.
2. Press the 'SET AUTOCLOSE TIME' button again **within 5 seconds** to disable AUTOCLOSE.

SETTING THE EXTENDED LIMIT (2nd is Applicable only if you have second arm)

Setting the CLOSED Limit (PULL-TO-OPEN Installation):

1. Move the gate(s) to the desired CLOSED position using the remote or the 1st Set/2nd SET JOG CLOSE or JOG OPEN buttons.  The JOG buttons can be used as 'fine' adjustment of the CLOSED limit.
2. Press and hold the 1st SET/ 2nd SET button until the alarm sounds, then release the button.
3. Press the remote to run the gate(s) to the fully OPEN position. (Repeat Steps 1-3 if needed.)
4. The unit will beep once to indicate that the new CLOSED limit is learned and stored. Verify the newly programmed closed limit by running the gate from the **OPEN** limit to **CLOSED** limit.

Setting the OPEN Limit (PUSH-TO-OPEN Installation):

1. Move the gate(s) to the desired OPEN position using the remote or the JOG CLOSE or JOG OPEN buttons.  The JOG button can be used as 'fine' adjustment of the OPEN limit.
2. Press and hold the 1st SET/ 2nd SET button until the alarm sounds, then release the button.
3. Press the remote to run the gate(s) to the fully CLOSED position. (Repeat Steps 1-3 if needed.)
4. The unit will beep once to indicate that the new OPEN limit is learned and stored.
5. Verify the newly programmed open limit by running the gate from the CLOSED to OPEN limit.

LED INDICATORS

○ = OFF ● = ON ⚙ = SLOW BLINKING ⚙ = RAPID BLINKING

POWER LED (GREEN)

- = NO input power present
- = Transformer power present
- ⚙ = Solar panel power present

BATTERY CONDITION LED (YELLOW)

- ⚙ = FULLY CHARGED battery (Rapid)
- = GOOD battery ⚙ = LOW battery
- This LED will turn off after 1 min. of inactivity

STATUS LED (RED)

- ⚙ =1 = Blink once= Input change detected
- ⚙ >1 = (Blink more than once)= Blink along with alarm to provide visual feedback of various codes

AUTOCLOSE LED (GREEN)

- = AUTOCLOSE disabled
- = AUTOCLOSE enabled
- ⚙ = AUTOCLOSE suspended

XMTR LED (YELLOW)

- = No transmitter signal
- = Learn transmitter mode
- ⚙ = Transmitter signal detected

ALARM CODES

(Alarm Codes are only active for 1 minute after gate has stopped moving, except where required by safety standard)

Test Battery Condition (on 5 button remote only)

- 1 Beep = GOOD Battery
- 4 Beeps = LOW Battery

Cycling Control Box Power Switch will disable PartyMode® and VacationMode®

PartyMode® (Hold Open)

- 2 Beeps = PartyMode® Enabled
- 3 Beeps = PartyMode® Disabled

VacationMode® (Hold Closed)

- 2 Beeps = VacationMode® Enabled
- 3 Beeps = VacationMode® Disabled

Arm Connection

- 5 Beeps = 1st Arm Disconnected
- 6 Beeps = 2nd Arm Disconnected
- 7/8 Beeps = Replace F1 fuse. Replace F2 fuse for duals only

I PRESS MY TRANSMITTER AND NOTHING HAPPENS (NO BEEPS/NO MOVEMENT)

The Number 3 dip switch (blue box of 4 switches on your system control board) is in the wrong position. It must be positioned to the left. (toward s.force). The only condition/reason to have it to the right is if you are using additional Ghost Controls' monitored external photo beams (AXPE).

I GET 5 BEEPS AND NO OPERATION.

Turn the system off and remove the 1st operator arm wires from the terminal. Check terminal and wire condition, replace wires according to color code and turn the system back on. Test System.

I GET 7 BEEPS AND NO OPERATION.

This beep means no movement was detected from the 1st operator arm.

Replace the RED F1 10amp fuse on the system control board. Test System.

Turn the system off and remove the 1st. operator arm wires from the terminal. Check terminal and wire condition, replace wires according to color code and turn the system back on. Test System.

I GET 8 BEEPS AND NO OPERATION.

This beep means no movement was detected from the 2nd operator arm.

Replace the RED F2 10amp fuse on the system control board. Test System.

Turn the system off and remove the 2nd operator arm wires from the terminal. Check terminal and wire condition, replace wires according to color code and turn the system back on. Test System.

I AM HAVING TROUBLE GETTING THE GATE TO MOVE WITH THE JOGS BUTTONS DURING SETUP. (SINGLE PULL TO OPEN GATES).

Use a working remote to set your limit.

Activate the gate to close with the remote transmitter.

When the gate reaches the desired closed position press and release the remote transmitter button. This will stop the gate. You may need to use the jog to fine tune the position.

Press and hold down the 1st set button until it beeps and release.

Activate the gate to open with the remote transmitter and the gate will return to full open and beep one time. It has learned its closed limit position.

(SINGLE PUSH TO OPEN GATES).

Use a working remote to set your limit.

Activate the gate to open with the remote transmitter.

When the gate reaches the desired open position press and release the remote transmitter button. This will stop the gate. You may need to use the jog to fine tune the position.

Press and hold down the 1st set button until it beeps and release.

Activate the gate to close with the remote transmitter and the gate will return to the full close and beep one time. It has learned its open limit position.

MY GATE PARTIALLY REOPENS AFTER CLOSING OR PARTIALLY RE-CLOSES AFTER OPENING.

This a limit adjustment issue or bracket placement. Please review your installation. Remember that on pull to open gates the open gate position is determined by bracket placement with a fully retracted operator arm. For Push to open gates the closed gate position is determined by bracket placement with a fully retracted operator arm.

LED Indicators on System Control Board

"POWER STATUS" LED GREEN = ON = transformer power present BLINKING = solar panel power present OFF = no power present / not currently charging

"BATTERY CONDITION" LED YELLOW = ON = battery good BLINKING SLOWLY = low battery
BLINKING RAPID = fully charged OFF = Unit has been on longer than 1 minute (LED times out) or no battery detected.

"STATUS" LED Red = BLINKS ONCE = input change detected (exit sensor, wired push button activated, etc..)

BLINKS CONTINUOUSLY = blinks along with alarm codes to provide visual feedback. Also, it could mean a potential accessory issue. Disconnect accessories connected to the "Hardwired Inputs" terminal and test system.

PROGRAMMING A NEW REMOTE CAUSES MY OTHER REMOTE(S) TO STOP WORKING.

Only one remote transmitter is learned to the control board. See the inside cover of your control box for instructions. All others must be cloned from that remote transmitter. See transmitter manual or ghostcontrols.com for more information.

CONNECTING OPTIONAL HARDWIRED ACCESSORIES

CONNECTING TO CONTROL BOARD

NOTE

Please refer to the manufacturer's manual or website for more detailed instructions on how to connect and use accessories from other manufacturer's with your Ghost Controls® gate opener.

PREPARING CONTROL BOX FOR ACCESSORY WIRING

Make sure the power is turned off which is located on bottom of the control board before wiring.

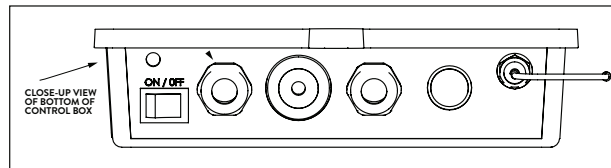

CONNECTING GHOST CONTROLS ZOMBIE GATE LOCK (AXZL)

- ONLY ACCEPTS patented GHOST CONTROLS® AXZL Zombie Gate Lock with feedback system.
- Controller will automatically detect lock present and respond accordingly.
- Lock (if present) will be pulled (unlocked) for the first few seconds while opening. If lock is not completely pulled the gate will not open to prevent damaging to the gate and lock.
- Lock will also be pulled (unlocked) near the closed limit position as it is closing to ensure a smooth and “soft” operation.

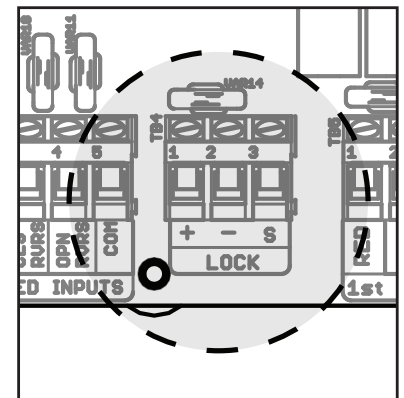

CONNECTING HARDWIRED DEVICES

Accepts “DRY CONTACT” input signals as control input. DRY CONTACT is passive (no power) such as a simple push button that switches from open to short circuit.

NOTE

INACTIVE – Opens circuit or has no connection.

ACTIVE – Input is shorted to COM or BATTERY NEGATIVE.

CYCLE INPUT (CYC): Use this terminal for Ghost Controls Push Button (XPB).

- **Active** – Signal must go from INACTIVE then ACTIVE for the system to recognize the input and respond accordingly. EX: OPEN > STOP > CLOSE > STOP > OPEN >...

OPEN INPUT (OPEN): Use this terminal for Ghost Controls Vehicle Detector (AXXV).

Active – OPENS gate to full open limit and prevents it from closing.

CLOSING-REVERSE INPUT (CLS-RVRS): Use this terminal with “unmonitored” photo eye beams or safety edge.

- **Active** – Prevents gate from CLOSING or reversing to open limit if it was CLOSING.

OPENING-REVERSE INPUT (OPN-RVRS): Use this terminal with “unmonitored” photo eye beams or safety edge.

- **Active** – Prevents gate from OPENING or reversing to close limit if it was OPENING. For use with “unmonitored” photo eyes.

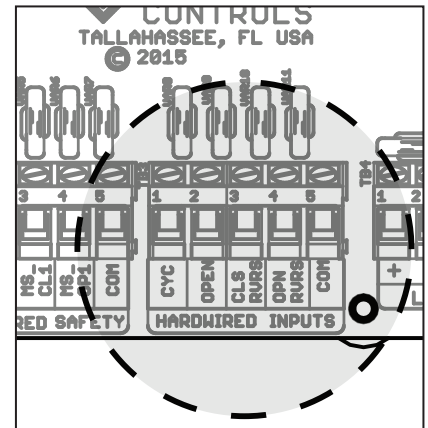

MONITORED SAFETY DEVICES ONLY – PHOTO EYES (AXPE)

NOTE

Please refer to manufacturer’s manual or website for more detailed instructions on how to connect and use accessories with your gate opener.

TERMINALS TO USE FOR REVERSE OPENING:

- PWR = Switched 12 Volts (+)
- MS-OP1 = Photos beam’s output for 1st arm open-direction protection
- MS-OP2 = Photos beam’s output for 2nd arm open-direction protection
- COM = BATTERY NEGATIVE

IF THE BEAM IS BLOCKED OR DEVICE IS DISCONNECTED

- Gate can not be open if idle
- Gate will reverse direction and run to the closed position if it was opening

TERMINALS TO USE FOR REVERSE CLOSING:

- PWR = Switched 12 Volts (+)
- MS-CL1 = Photos beam’s output for close-direction protection
- COM = BATTERY NEGATIVE

IF THE BEAM IS BLOCKED OR DEVICE IS DISCONNECTED

- Gate will not open if idle
- Gate will reverse direction and run to the open position if it was closing

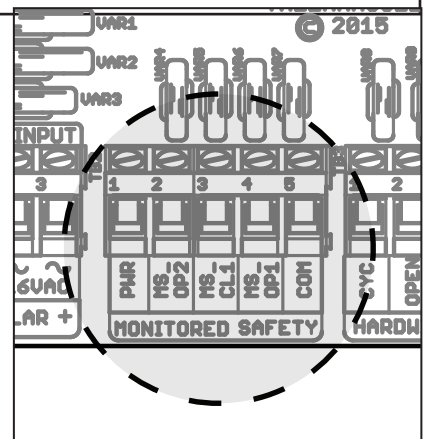

MANUAL GATE OPERATION

EVERY USER MUST KNOW THESE STEPS

The gate can be opened or closed manually by releasing the front mount from the gate.





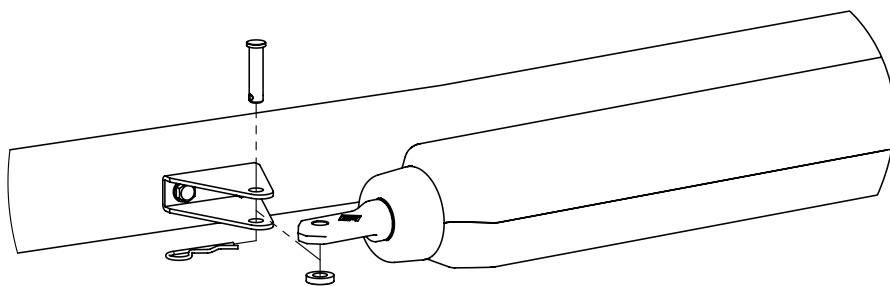
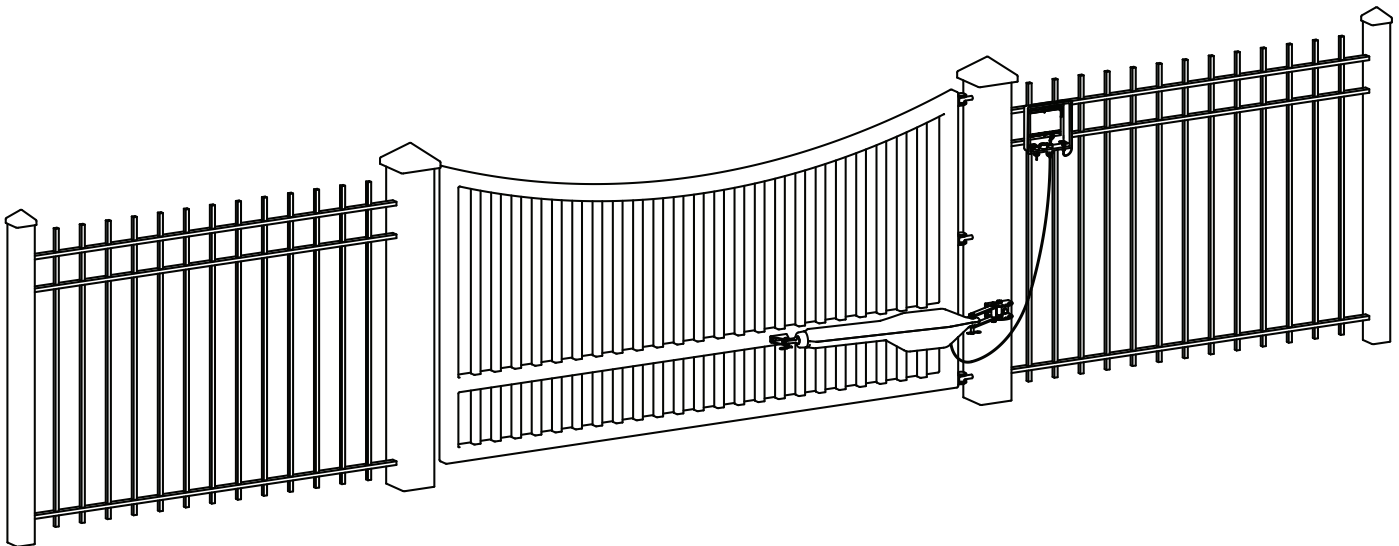





You must disconnect the operator only after the operator power switch is OFF and the gate is NOT moving. If you have the accessory ZombieLock® installed, this lock should be manually disengaged with the key because removing power does not unlock this lock.









1. **Make sure to turn your control box to the off position.** The gate operator is battery powered so unplugging the AC transformer does not turn the power to the operator off.
2. Remove the hairpin clip and clevis pin from the FRONT mount of the gate operator.
3. Swing the operator out of the way of the gate.
4. Swing the gate to the fully open position and temporarily secure it to prevent the gate from freely swinging.



ACCESSORIES

GHOST CONTROLS® genuine accessories are designed to provide complete control and superior convenience for you and your family with your automatic gate opener. These products are specifically engineered to easily integrate into your system and grant you access to additional capabilities and control of your gate opener. All of these accessories are available from your local dealer and are backed by the same reliable warranty that your gate operator is designed to meet.

<p>PREMIUM REMOTE TRANSMITTER AXP1 The premium remote transmitter (single or dual) provides the ability to open or close, enable or disable PartyMode®, determine gate opener system battery status, and can be quickly added as a new remote to an existing system. CR2032 Battery Included.</p>	
<p>STANDARD REMOTE TRANSMITTER AXS1 The standard remote transmitter will control up to two separate GHOST CONTROLS® gate systems (single or dual) and it can be learned as a new remote to an existing system. CR2032 Battery Included.</p>	
<p>WATER-RESISTANT REMOTE TRANSMITTER AXR1 The water-resistant remote transmitter will control up to two separate GHOST CONTROLS® gate systems (single or dual) and it can be learned as a new remote to an existing system. CR2032 Battery Included. Includes adapter plate to be attached to round object such as motorcycle or ATV handlebars. Ideal for outdoor use on motorcycles, golf carts, and ATVs.</p>	
<p>WIRELESS KEYPAD AXWK The GHOST CONTROLS® Premium Wireless Keypad is the superior gateway to your gate opener system and provides unprecedented control and capabilities. This outdoor keypad is more than just an access point for visitors to your home or property who do not have a remote transmitter because it also provides the ability for you to activate or deactivate additional features for your keypad such as VacationMode™.</p>	
<p>OUTDOOR MOUNTING PEDESTAL AXGN A simple and convenient solution for adding a Wireless Keypad or our Water Resistant Remote Transmitter to any post or column. This bracket is powder-coated aluminum and allows added convenience for access to a keypad from any vehicle.</p>	
<p>PREMIUM 10 WATT MONOCRYSTALLINE SOLAR PANEL AXDP The monocrystalline 10W solar panels are a great solution for anyone who is installing a gate operator system in a remote location that does not have easy access to 120V AC power or for those who do not want to be "on the grid". Hardware and mounting post included.</p>	
<p>PREMIUM 30 WATT MONOCRYSTALLINE SOLAR PANEL AX30 The monocrystalline 30W solar panels are a great solution for anyone who is installing a gate operator system in a remote location that does not have easy access to 120V AC power or for those who do not want to be "on the grid". Mounting post, not included.</p>	
<p>BATTERY BOX KIT WITH 2 12V BATTERIES ABBT2 The GHOST CONTROLS® Battery Box Kit powers up your gate opener system. It includes two 7 Amp hour 12V batteries in the box. Battery box kit gets mounted next to the control panel.</p>	
<p>12 VOLT , 7 AMP HOUR LEAD ACID BATTERY AXBT Batteries provide the primary power to the gate opener system and are installed within the ABBT battery box when auto/marine batteries are not used.</p>	
<p>ZOMBIELOCK® AXZL The patent pending ZombieLock® will provide your home with the latest in automatic gate lock technology with advanced feedback to your GHOST CONTROLS® gate controller. For use on single gates maximum length 16' and for use on double gates with 24' maximum gate opening.</p>	

<p>UNIVERSAL TUBE GATE BRACKET KIT AXTB</p> <p>Mounting bracket kits that will attach a variety of devices to 1-1/2"-2" tubes including tubular gates. These include gate opener kits, ZombieLock®, or any other device that needs to be attached to tubes.</p>	
<p>WIRED VEHICLE SENSOR AXXV</p> <p>The GHOST CONTROLS® Vehicle Sensor is the easiest way to trigger your gate to open when a vehicle is trying to exit your property. This sensor is buried beneath the ground surface next to your driveway and connects into your gate controller box. 55' cable included (cannot be spliced)</p>	
<p>WIRELESS VEHICLE SENSOR AXWV</p> <p>The GHOST CONTROLS® Vehicle Sensor is the easiest way to trigger your gate to open when a vehicle is trying to exit your property. This sensor is easy to install and sensor is buried beneath the ground surface next to your driveway and takes 2 C batteries. Does not connect into the control box.</p>	
<p>PUSH BUTTON AXPB</p> <p>The standard push button will control a single or dual gate system up to 1,000' ft away with low voltage wire.</p>	
<p>LOCKING CLEVIS PIN AXLC</p> <p>The GHOST CONTROLS® Locking Clevis Pin allows you to easily secure the mounting brackets and rear mount of the gate operator to the post with a padlock. The locking clevis pin replaces the clevis pin that is included in the gate opener kit.</p>	
<p>100' WIRE AXLV</p> <p>100' of 16 AWG low voltage, direct burial, standard wire for wiring the transformer or running the power cable from solar panel.</p>	
<p>PHOTO EYES AXPS OR AXPE</p> <p>Adjustable photo eyes for your outdoor environment. We offer monitored and non-monitored versions.</p>	
<p>PUSH-TO-OPEN GATE BRACKET KIT AXPO</p> <p>The Push-To-Open Bracket is required for any gate opener system that is installed when the installation causes the gates to swing out from the property. Most gates are installed with the swing action into the property and do not require these brackets. Dual gates will need (2) AXPO kits.</p>	
<p>GHOST MULTI CONNECT™ AXMC-R</p> <p>Installing the Ghost Multi Connect™ Kit to your Ghost Control Board can allow you to access and control your automatic gate from your phone using bluetooth or wifi if you have internet at your gate. Once the Ghost Multi Connect™ Kit is installed you will need to download our customized app (free on apple and google store) to your phone, Ipad, or tablet using wifi at your gate. Don't have internet at the gate? You can utilize the bluetooth feature. The Ghost Multi Connect™ Kit also works in parallel with your traditional remote transmitter.</p> <p>* You may need an upgraded board depending on which control board your system has.</p>	