

# Index

ENGLISH

<b>GENERAL SAFETY INSTRUCTIONS FOR INSTALLATION AND MAINTENANCE</b> .....	p. 2
<b>TOOLS AND MATERIALS</b> .....	p. 2
<b>DECLARATION OF CONFORMITY</b> .....	p. 3
<b>WARNINGS FOR THE INSTALLER</b> .....	p. 3
<b>1 DIMENSIONS</b> .....	p. 4
<b>2 TECHNICAL SPECIFICATIONS</b> .....	p. 4
<b>3 ANCILLARY ELECTRICAL EQUIPMENT</b> .....	p. 4
<b>4 DESCRIPTION</b> .....	p. 5
<b>5 PRELIMINARY CHECKS</b> .....	p. 5
<b>6 ASSEMBLY</b> .....	p. 6
6.1 Sliding guide .....	p. 6
6.2 Rear fitting .....	p. 6
6.3 External release (optional) .....	p. 7
<b>7 INSTALLATION</b> .....	p. 7
7.1 Sliding guide .....	p. 7
7.2 On-door fitting .....	p. 8
7.3 Operator .....	p. 9
7.4 Releasing the automated system .....	p. 9
7.5 External release .....	p. 9
<b>8 E600 CONTROL BOARD</b> .....	p. 10
8.1 Technical specifications .....	p. 10
8.2 E600 board components .....	p. 10
8.3 Terminal-boards and connectors .....	p. 10
8.4 DS1 Programming dip-switches .....	p. 10
8.5 Operating logics .....	p. 10
<b>9 COURTESY LIGHT</b> .....	p. 11
<b>10 CONNECTIONS</b> .....	p. 11
<b>11 PROGRAMMING</b> .....	p. 12
11.1 Setting the board .....	p. 12
11.2 Learning .....	p. 12
11.3 Pre-flashing .....	p. 13
<b>12 MEMORY STORAGE OF RADIO CONTROLS CODING</b> .....	p. 14
12.1 Memory storage of radio controls DS .....	p. 14
12.2 Memory storage of radio controls SLH .....	p. 14
12.3 Memory storage of radio controls LC (for some markets only) .....	p. 14
12.3.1 Remote memory storage of LC radio controls .....	p. 15
12.4 Radio controls deletion procedure .....	p. 15
<b>13 START-UP</b> .....	p. 15
<b>14 PARACHUTE CABLES</b> .....	p. 15
<b>15 MAINTENANCE</b> .....	p. 15
<b>16 REPAIRS</b> .....	p. 15
<b>17 ACCESSORIES</b> .....	p. 16
17.1 Central support .....	p. 16
17.2 Key-operated release .....	p. 16
17.3 Safety edge CN60E .....	p. 16
17.4 Battery KIT .....	p. 16
<b>18 TROUBLESHOOTING</b> .....	p. 17

## GENERAL SAFETY INSTRUCTIONS FOR INSTALLATION AND MAINTENANCE

*For an efficient and safe automated door, correctly observe the installation procedures and instructions for use. Incorrect installation and use can cause serious damage to persons and property.*

Carefully read the whole installation manual before you begin installing.  
Do not make any modifications which are not mentioned in this manual.  
Do not install the operator for uses other than those indicated.  
To fasten, use the supplied accessories or, in any case, fastening systems (screws, expansion plugs, etc.) suitable for the type of support and for the mechanical stresses exerted by the automated system.

Check if the sectional door conforms to standards EN12604 and EN 12605 (the information can be found in the documentation accompanying the door itself). For non-EU countries, the above mentioned standards must be observed in addition to the national standard references to obtain a suitable safety level.  
Make sure that the door is correctly balanced, correctly operational, and supplied with mechanical opening stops.

When installing we advise you to:

- obtain the material and tools indicated in the following paragraph "Tools and materials" and keep them near at hand.
- use a stable support for performing operations without a floor support.
- protect your face and hands adequately before making the holes with the drill.
- do not allow children to play near during installation, use and during the automated system release manoeuvre.
- remove any debris and objects which could hamper movement, before powering up the system.
- remove the door's closing mechanism to ensure the door is closed by the automatism.
- stick on the warning stickers as shown in the instruction.
- install the manual release devices at a height of not over 180cm.
- install the external control devices at a height of not below 150cm, clear of the door movement area, but in a position enabling visual control of the area.

When you have finished installing we advise you to:

- check if the anti-crushing device is able to detect a 50mm high object on the ground and if a weight of 20 kg applied to the door, causes the opening movement to stop.
  - make sure that no part of the door interferes with public spaces such as pavements and/or roads.
  - Use the automated system observing the instructions in the "User's guide".
  - Fill in, keep and update the maintenance register.
- The D600 automated system does not require periodic replacement of parts.
  - Every month, run a functional check of the safety devices and of the anti-crushing system: a non-deformable object with a height of 50 mm laid on the ground, must be correctly detected.



**IMPORTANT! DANGER OF CRUSHING.**

- If the power cable of operator D600 is damaged, it must be replaced by qualified personnel, using a new cable of the same type. Do not use different power cables.

## TOOLS AND MATERIALS

Tools you will require to install the D600 operator:

- a hammer drill with relevant wall and iron bits
- screwdrivers for cross-head and cut-head screws
- two flat wrenches for 13 mm hexagon head screws

Material required for installing the D600 operator and the relevant accessories (if present):

- cable 2x0,5 mm<sup>2</sup> (emitting photocells, pulse generators for opening movement and stop)
- cable 4x0,5 mm<sup>2</sup> (receiver photocells)
- cable 2x0,75 mm<sup>2</sup> (flashing lamp)
- cable 2 x1,5 mm<sup>2</sup> (power)

Use cables with an adequate degree of insulation.

The electric system must conform to the prescriptions in the chapter entitled "Warnings for the installer".

The 230 Vac power cable must be laid and connected by a qualified installation technician. Arrange for a 2P 10A 250 V socket to be installed near the operator.

Lay the cables in the appropriate pipes and do not allow loose cables to come into contact with moving parts of the automated system and the door.

## CE DECLARATION OF CONFORMITY FOR MACHINES (DIRECTIVE 98/37/EC)

**Manufacturer:** FAAC S.p.A.

**Address:** Via Benini, 1 - 40069 Zola Predosa BOLOGNA - ITALY

**Declares that:** Operator model. D600 with E600 unit,

- is built to be integrated into a machine or to be assembled with other machinery to create a machine under the provisions of Directive 98/37/EC;
- conforms to the essential safety requirements of the other following EEC directives:

73/23/EEC and subsequent amendment 93/68/EEC.  
89/336/EEC and subsequent amendment 92/31/EEC and 93/68/EEC

Furthermore, the manufacturer declares that the machinery must not be put into service until the machine into which it will be integrated or of which it will become a component has been identified and its conformity to the conditions of Directive 89/392/EEC and subsequent modifications assimilated in Italian National legislation under Presidential Decree No. 459 of 24 July 1996 has been declared.

Bologna, 01 January 2006

The Managing Director

A. Bassi  

ENGLISH

### WARNINGS FOR THE INSTALLER GENERAL SAFETY OBLIGATIONS

- 1) **ATTENTION! To ensure the safety of people, it is important that you read all the following instructions. Incorrect installation or incorrect use of the product could cause serious harm to people.**
- 2) Carefully read the instructions before beginning to install the product.
- 3) Do not leave packing materials (plastic, polystyrene, etc.) within reach of children as such materials are potential sources of danger.
- 4) Store these instructions for future reference.
- 5) This product was designed and built strictly for the use indicated in this documentation. Any other use, not expressly indicated here, could compromise the good condition/operation of the product and/or be a source of danger.
- 6) FAAC declines all liability caused by improper use or use other than that for which the automated system was intended.
- 7) Do not install the equipment in an explosive atmosphere: the presence of inflammable gas or fumes is a serious danger to safety.
- 8) The mechanical parts must conform to the provisions of Standards EN 12604 and EN 12605.  
For non-EU countries, to obtain an adequate level of safety, the Standards mentioned above must be observed, in addition to national legal regulations.
- 9) FAAC is not responsible for failure to observe Good Technique in the construction of the closing elements to be motorised, or for any deformation that may occur during use.
- 10) The installation must conform to Standards EN 12453 and EN 12445.  
For non-EU countries, to obtain an adequate level of safety, the Standards mentioned above must be observed, in addition to national legal regulations.
- 11) Before attempting any job on the system, cut out electrical power.
- 12) The mains power supply of the automated system must be fitted with an all-pole switch with contact opening distance of 3mm or greater. Use of a 6A thermal breaker with all-pole circuit break is recommended.
- 13) Make sure that a differential switch with threshold of 0.03 A is fitted upstream of the system.
- 14) Make sure that the earthing system is perfectly constructed, and connect metal parts of the means of the closure to it.
- 15) The safety devices (EN 12978 standard) protect any danger areas against **mechanical movement Risks**, such as crushing, dragging, and shearing.
- 16) Use of at least one indicator-light (e.g. FAACLIGHT) is recommended for every system, as well as a warning sign adequately secured to the frame structure, in addition to the devices mentioned at point "15".
- 17) FAAC declines all liability as concerns safety and efficient operation of the automated system, if system components not produced by FAAC are used.
- 18) For maintenance, strictly use original parts by FAAC.
- 19) Do not in any way modify the components of the automated system.
- 20) The installer shall supply all information concerning manual operation of the system in case of an emergency, and shall hand over to the user the warnings handbook supplied with the product.
- 21) Do not allow children or adults to stay near the product while it is operating.
- 22) Keep remote controls or other pulse generators away from children, to prevent the automated system from being activated involuntarily.
- 23) Transit under the door must occur only when the automated system has stopped.
- 24) The user must not attempt any kind of repair or direct action whatever and contact qualified personnel only.
- 25) Maintenance: check at least every 6 months the efficiency of the system, particularly the efficiency of the safety devices (including, where foreseen, the operator thrust force) and of the release devices.
- 26) **Anything not expressly specified in these instructions is not permitted.**

# AUTOMATED SYSTEM D600

These instructions apply to model **FAAC D600**.

The D600 automated systems make it possible to automate balanced sectional doors of single garages for residential use.

They consist of an electro-mechanical operator, electronic control unit and courtesy light built into a single unit. This unit is fitted to the ceiling and opens the door by means of a transmission chain or belt.

The system is non-reversing and, therefore, the door locks mechanically when the motor is not operating and, consequently, no lock is necessary; two manual releases, one on the inside and one on the outside (optional) make it possible to move the door in case of a power cut or fault.

The operator is supplied with an electronic device that detects the presence of an obstacle that would hinder door movement - the device prevents crushing or lifting.

This instruction refers to the operator with chain drive, but the same procedures, regulations and application limits apply also to the belt driven operator.

**The D600 automated systems were designed and built for indoor use and to control vehicle access. Do not use them for any other purpose.**

## 1 DIMENSIONS

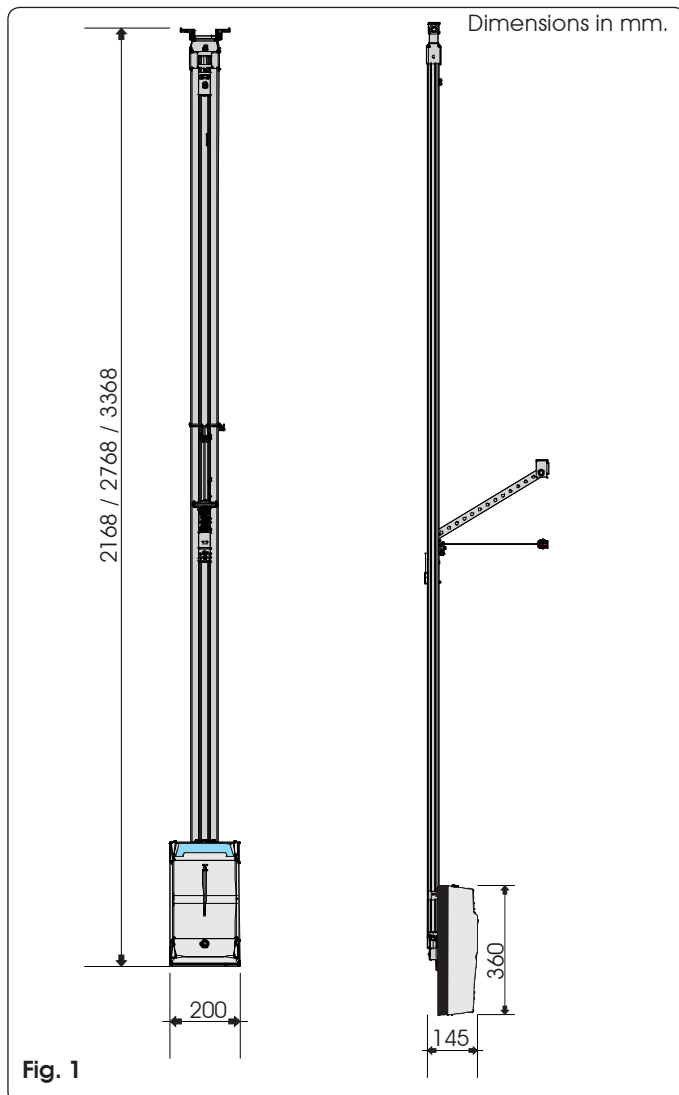

## 2 TECHNICAL SPECIFICATIONS

Model	D600
Power supply (V ~ / 50 Hz.)	230
Electric motor (Vdc)	24
Maximum absorbed power (W)	220
Thrust force (N)	600
Type of use	continuous
Maximum dimensions from ceiling (mm)	35 (Fig. 4)
Courtesy light (V ~/W)	230 / 40 max.
Courtesy light timer (sec)	120
Standard speed with no-load carriage (m/min)	6,6
Slow speed with no-load carriage (m/min)	3,8
Carriage deceleration speed (m/min)	1,3
Noise at standard speed (dB(A))	52
Travel length at deceleration	varies according to set-up
Intrinsic safety device	Category 2
Maximum sectional door width (mm)	5000
Maximum sectional door height (mm)	(see useful travel)
Sliding guide useful travel (mm)	1900 - 2500 - 3100
Protection class	for indoor use only (IP20)
Operating ambient temperature (°C)	-20 / +55

The level of noise emission of operator D600, referred to the work station, is 52 dB(A).

## 3 ANCILLARY ELECTRICAL EQUIPMENT

Prepare the electric system in keeping with the instructions in the chapter entitled "Warnings for the installer". When you have finished installing, check if any external pipes or cables can come into contact with moving parts. Install the fixed control points at a minimum height of 150 cm, clear of the door movement area, but in a position enabling visual control of that area.

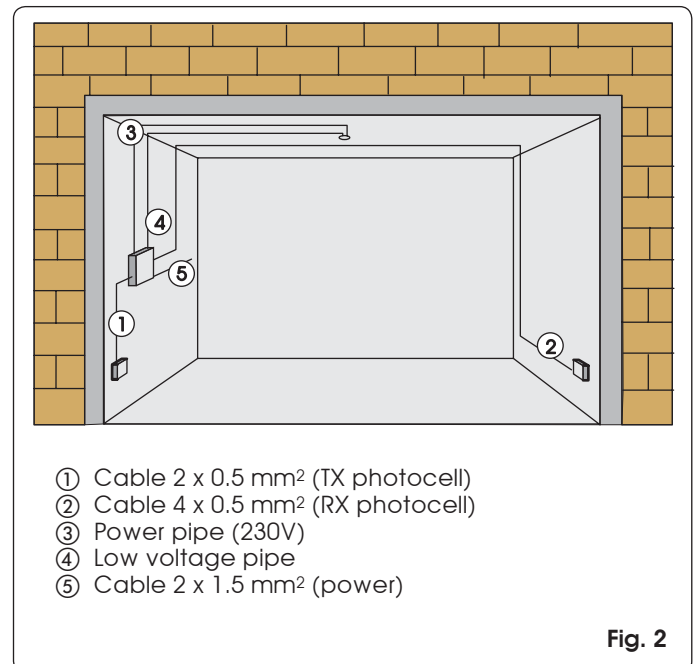

**4 DESCRIPTION**

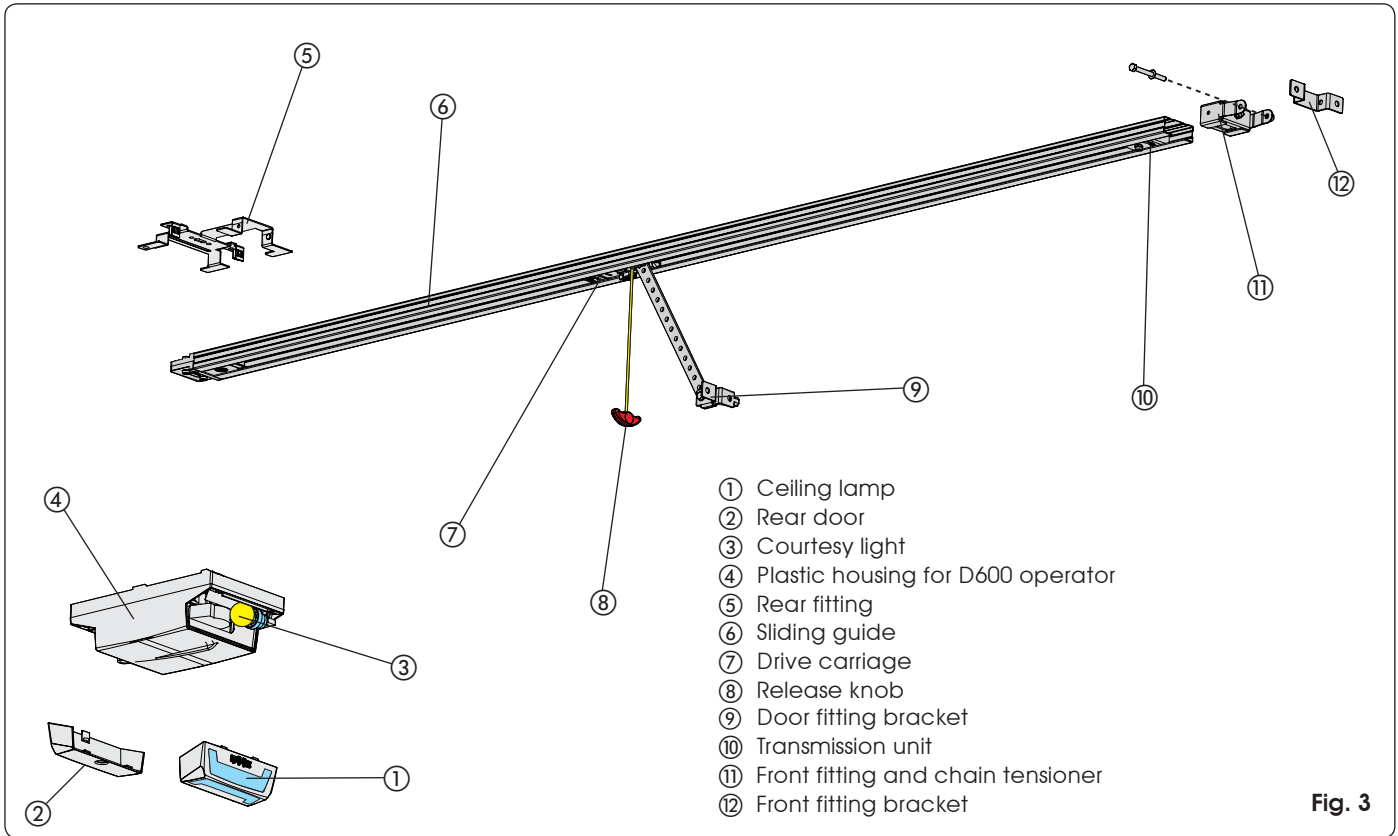
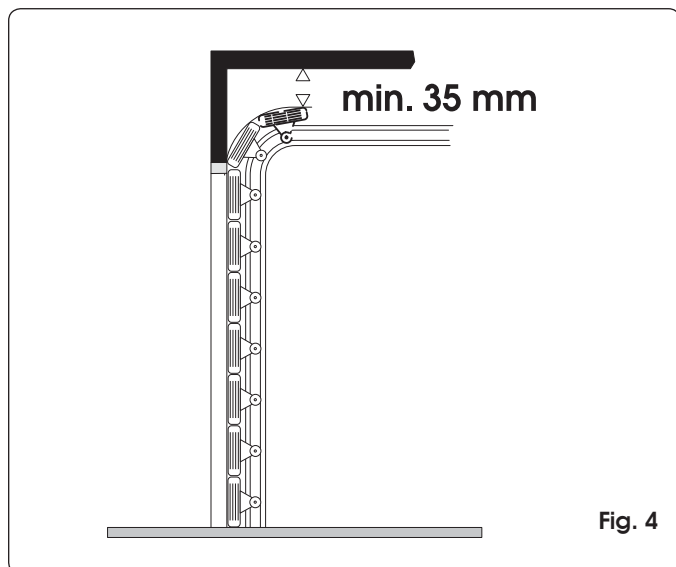

**Fig. 3**

**5 PRELIMINARY CHECKS**

- The structure of the door must be suitable for fitting automation. In particular, check that the door dimensions conform to those indicated in the technical specifications, and that it is sufficiently sturdy.
- Check if the door conforms to standards EN12604 and EN12605.
- As it moves, the door must not encroach public areas dedicated to pedestrian or vehicular transport.
- Check the efficiency of the door bearings and joints.
- Make sure that the door is friction-free. If necessary clean and lubricate the guides with silicone based products, but do not use grease, and, in any event, follow the manufacturer's instructions.
- Check correct balance and if the opening mechanical stops

- have been installed.
- Remove the door's existing closing mechanism to ensure the door is closed by the automated system.
- Make sure there is a clearance of at least 35 mm between the ceiling and the highest sliding point of the door (Fig.4).
- Check if the upper guide roller of the sectional door is in the horizontal part of the guide while the door is closed (fig. 5).



**Fig. 4**

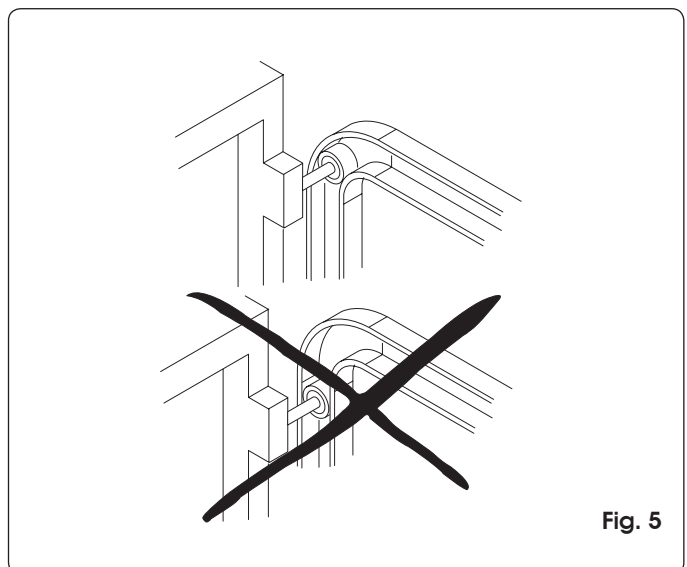

**Fig. 5**

**6 ASSEMBLY**

**6.1 Sliding guide**

If you use a sliding guide in two pieces, you must assemble it, as explained below. If you have a pre-assembled guide, go on to paragraph 6.2.

- 1) Assemble the two pieces of the sliding guide, fitting them in the central joint (Fig. 6 ref. A) until they come to a stop against the metal reference reliefs (Fig. 6 ref. B). To facilitate engaging the sliding guide, we advise you to insert it in the central joint, compressing it as shown in Fig. 6 ref. C. Do not use tools which could deform the guide or joint.

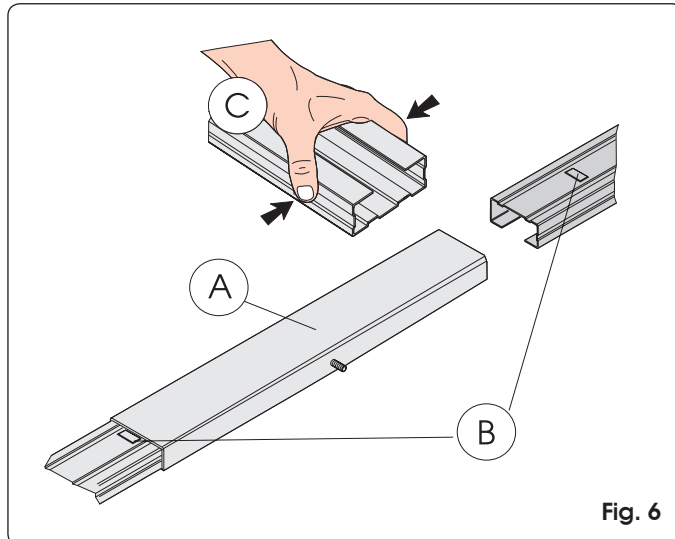

Fig. 6

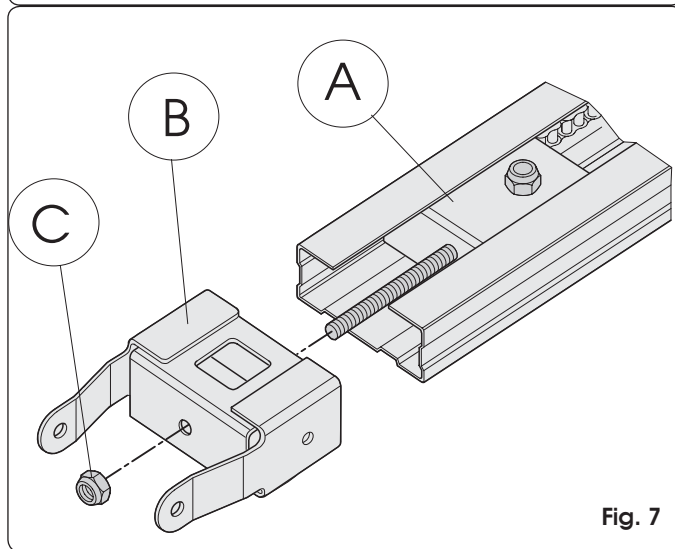

Fig. 7

- 2) Slide the transmission unit (Fig.7 ref. A) along the whole sliding guide, until it is near the front terminal, the one opposite the drive coupling.
- 3) Assemble the front fitting (Fig. 7 ref. B) to the transmission unit (Fig. 7 ref. A).
- 4) Apply slight tension to the chain, tightening the nut (Fig. 7 ref. C.).
- 5) Place the sliding guide on the side (Fig. 8).
- 6) Push the carriage toward the drive clutch unit (Fig.8 ref. C).
- 7) Adjust the tensioner (fig. 8 ref. A) so that the central zone of the loop, formed by the top branch of the chain, coincides with about the mid-point of the sliding guide (Fig. 8 ref. B)

**Attention: too much tension can cause damage to the transmission and drive clutch units.**

**6.2 Rear fitting**

Before securing the sliding guide to the ceiling, assemble the rear fitting in the seat of the drive clutch unit and fasten the screws as shown in Fig. 9 ref. ①.

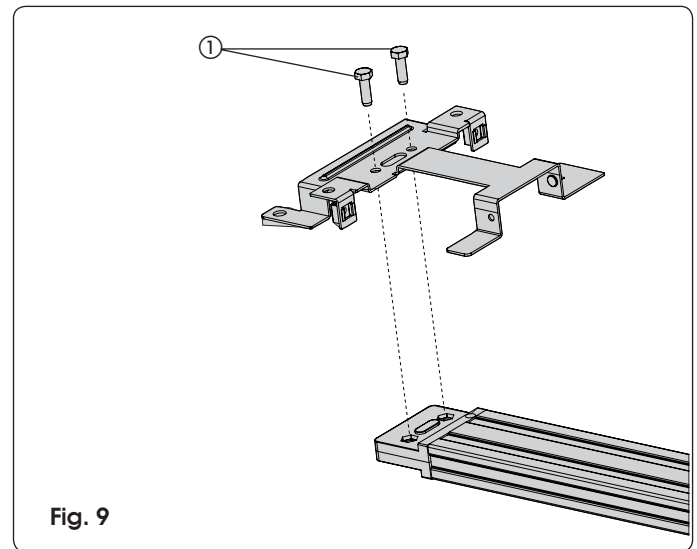

Fig. 9

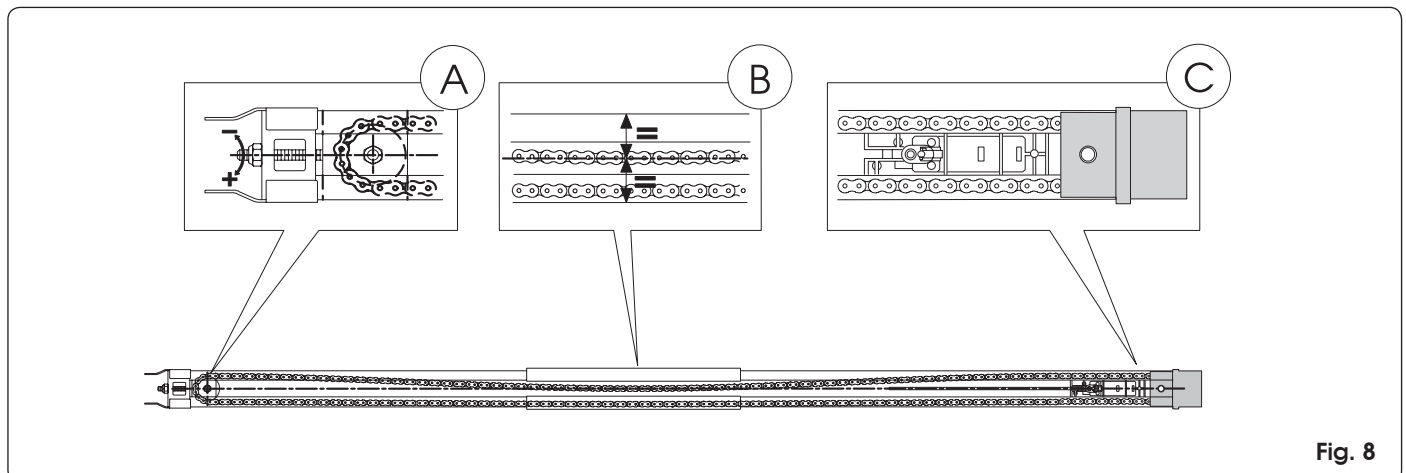

Fig. 8

**ENGLISH**



**6.3 External release (optional)**

If the external release system has to be installed, the cable must be placed in its seat before beginning to install.

- 1) Release the carriage (see par. 7.4 point 3), and take it to the slot on the top of the sliding guide.
- 2) Fit the cable terminal on the red seat (Fig. 10).
- 3) Take the carriage back toward the drive clutch unit until the through-hole on the carriage coincides with the slot, and fit the unsheathed cable (Fig. 11).
- 4) Fully withdraw the cable from the bottom of the carriage.
- 5) Wind the cable around itself to prevent it getting in the way while the sliding guide is being installed.

**7 INSTALLATION**

- To ensure you work in safe conditions, we advise you to install the operator while keeping the door fully closed.
- Use all the specified anchorage points.
- The fastening systems must be suitable for the type of support and sufficiently tough.
- Protect your hands and face adequately while drilling the holes.
- Read this chapter to the full before you begin installing.



ENGLISH

**7.1 Sliding guide**

When you have finished the preliminary assembly operations, you can begin installing the sliding guide, as follows:

- 1) On the architrave, mark a line corresponding to the vertical mid-point of the door (Fig. 12).
- 2) On the architrave, mark a horizontal line corresponding to the maximum height reached by the door during movement (see Fig. 4).
- 3) Position the securing bracket of the front fitting, so that the lower edge is at least 5 mm above the intersection point of the lines and centred with respect to the vertical line (Fig. 12). Also refer to paragraph 7.2 for correct positioning of the bracket with respect to the fitting point on the door.
- 4) Mark the two securing points.
- 5) Next, drill and install, using the screws (ref. ① Fig. 12) **NOT** supplied.
- 6) Position the sliding guide on the floor, perpendicular with respect to the door.
- 7) Lift guide off the front fitting and assemble the latter with the securing bracket, using the through screw and nut (Fig. 13).

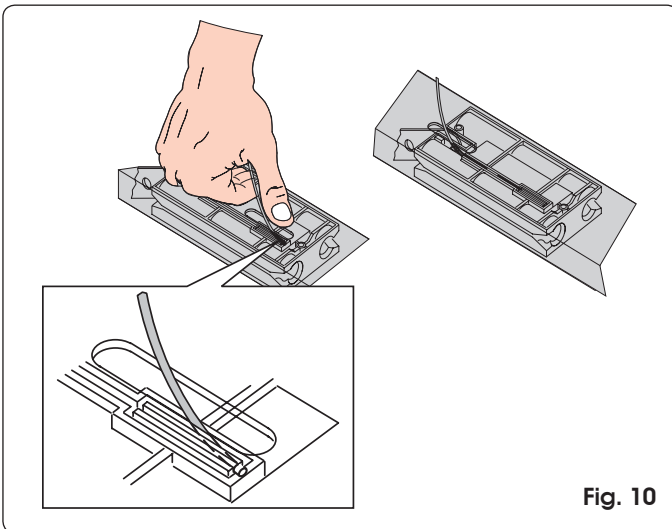

Fig. 10

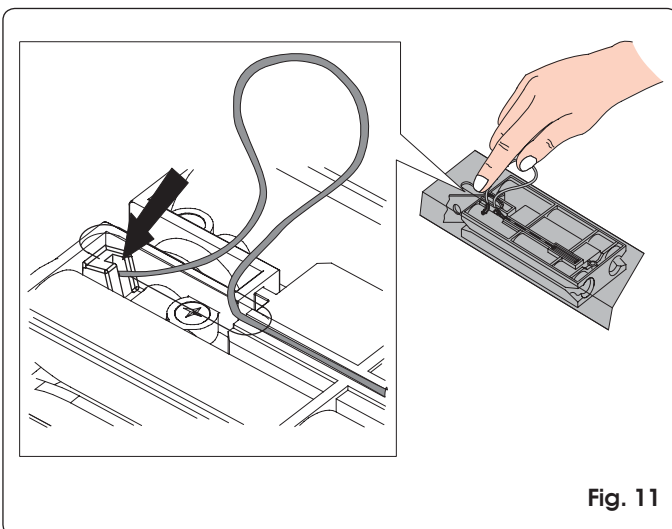

Fig. 11

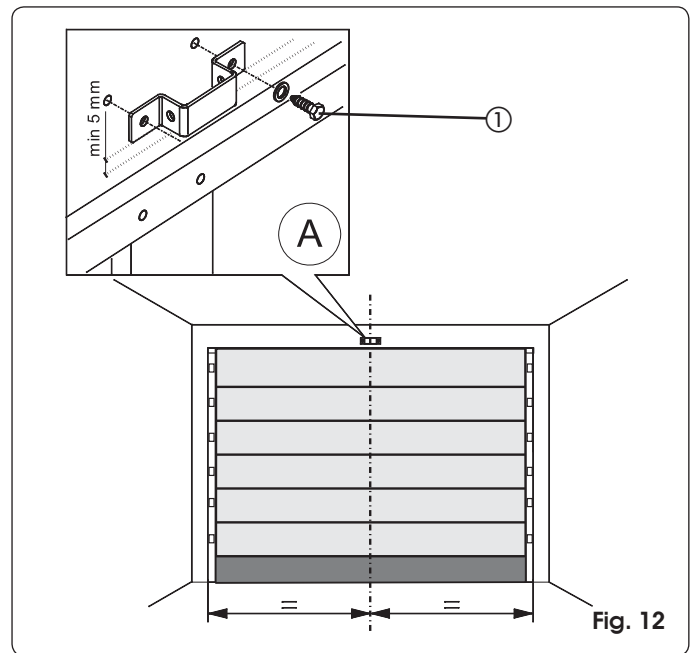

Fig. 12

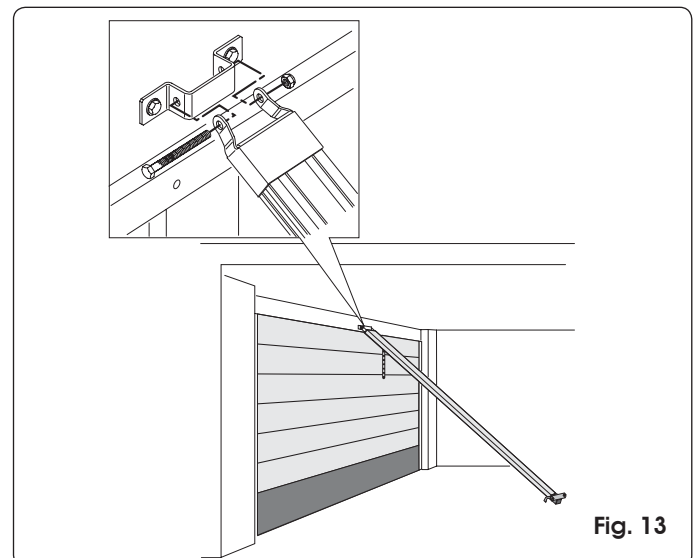

Fig. 13

- 8) Lift the sliding guide until the rear fitting is at the same level as the front fitting, or until you reach the same inclination as the door's horizontal rail. If you are securing directly to the ceiling, go to point 12.
- 9) Measure the distance between the ceiling and the between-axis position of the nuts securing the rear fitting.
- 10) Bend the supplied brackets according to the measurement you have taken (measure starting from the centre of the bracket's first slot).
- 11) Fit the brackets on the rear fitting and re-position the sliding guide (Fig. 14).
- 12) Mark the on-ceiling securing points of the rear fitting and drill (taking care to protect the sliding guide). Finish installing the guide.
- 13) If using a two-piece guide with central joint (Fig. 15 ref. A) or the central support for a single rail (Fig. 15 ref. B - optional), secure to the ceiling, using the brackets and proceed according to steps 9, 10 and 12 (Fig. 15).

### 7.2 On-door fitting

- 1) Assemble the fitting with the carriage rod (Fig. 16).

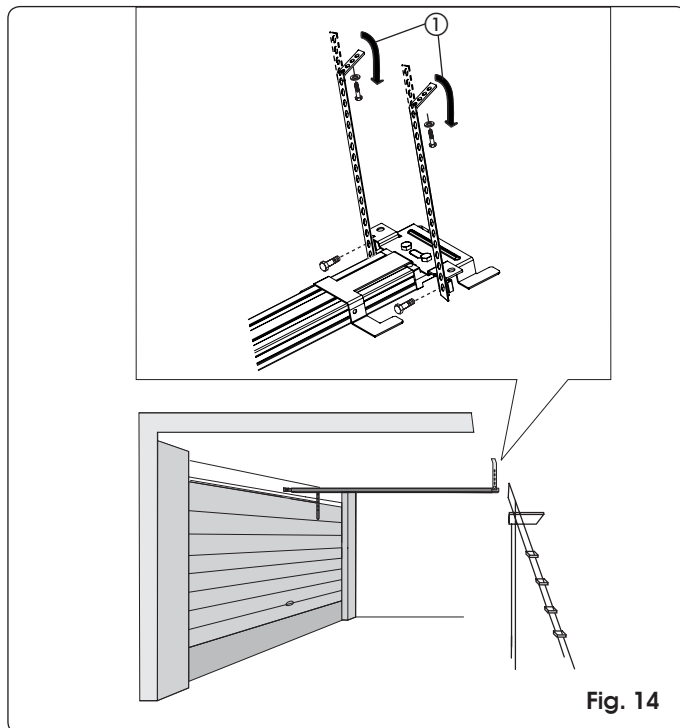

Fig. 14

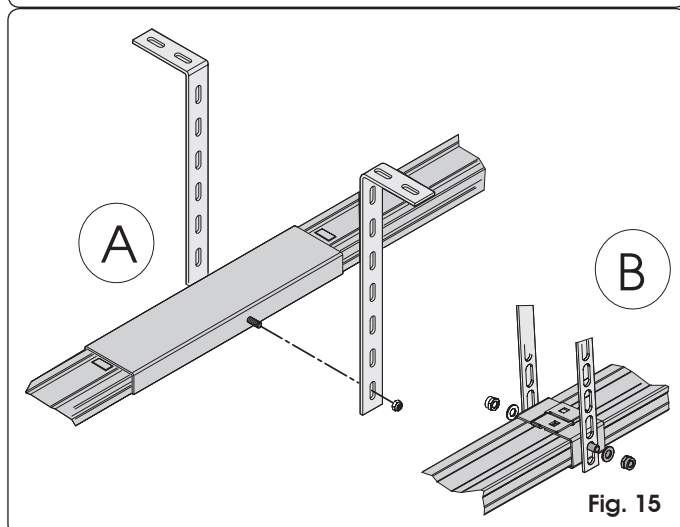

Fig. 15

- Position the fitting on the door so that the through-element of the release cable is facing toward the left side of the door (ref. ① Fig. 17).
- 2) Close the door and take the carriage near to it.
- 3) Position the fitting on the door, centred with respect to its mid-point.
- 4) Make sure that the distance between the between-centres of the front fitting and the on-door fitting does not exceed 20 cm (Fig. 17). To ensure correct operation of the automated system, we advise you to avoid arm inclinations of over 30° compared to the sliding guide. If using the curved arm for sectional doors (optional), carry out the assembly with the straight arm of the carriage as shown in Fig. 18. To improve efficiency of the anti-crushing system, we advise you to secure the fitting on the sectional door as low as possible, without, however, exceeding the distance of 40 cm from the operator's front fitting.
- 5) Mark, drill and secure the fitting to the door, using the screws (ref. ② Fig. 17) **NOT** supplied.

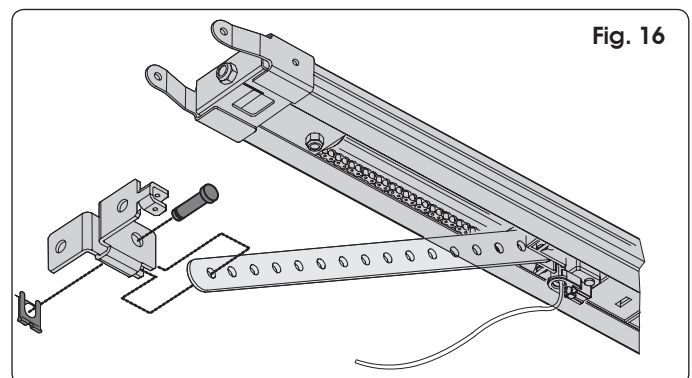

Fig. 16

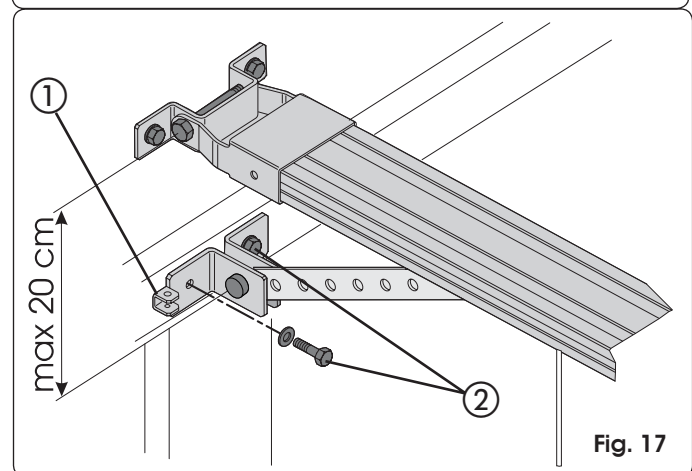

Fig. 17

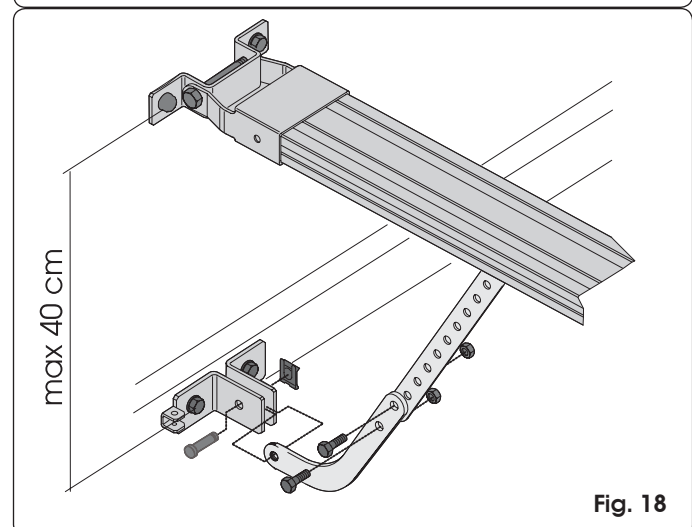

Fig. 18



### 7.3 Operator

When you have assembled the rear fitting to the sliding guide and finished installing the sliding guide, you can install the operator:

- 1) While keeping the operator inclined at 15°/20° (Fig. 20), insert the gearmotor shaft in the coupling on the rear fitting of the sliding guide and make the fins (Fig. 19 ref. ①) near to the seats at the bottom of the operator base (Fig. 19 ref. ②).
- 2) Turn the operator in the direction of Fig. 20 until you reach position of Fig. 21, and fit the pin in the hole of the rear fitting (Fig. 21 ref. ①).

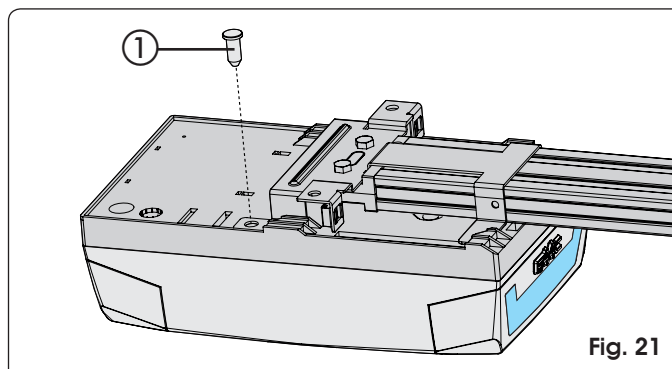

Fig. 21

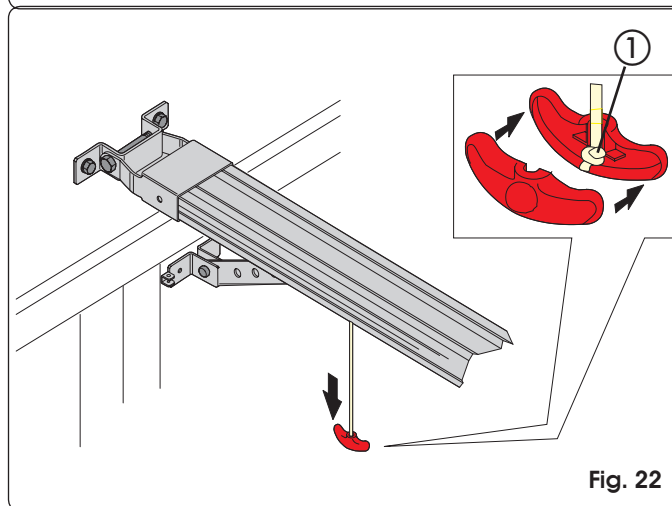

Fig. 22

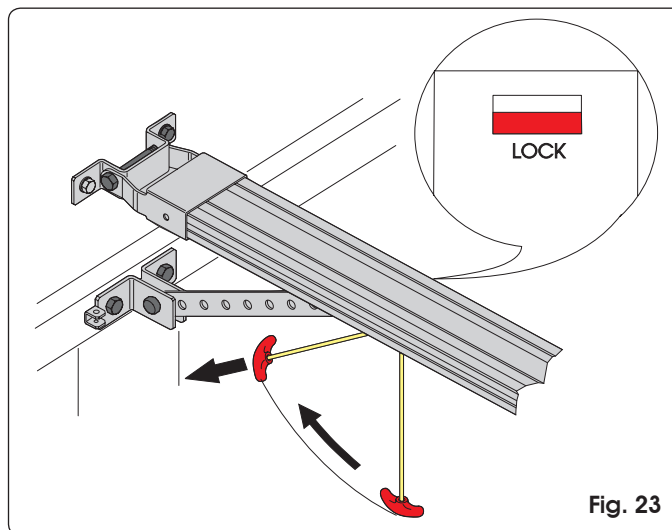

Fig. 23

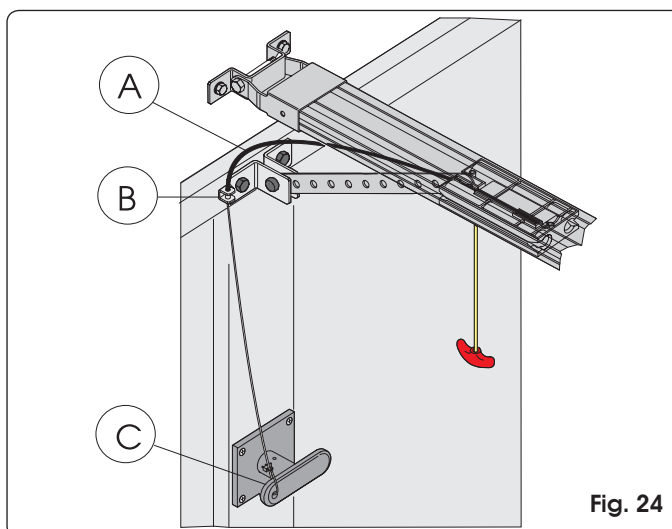

Fig. 24

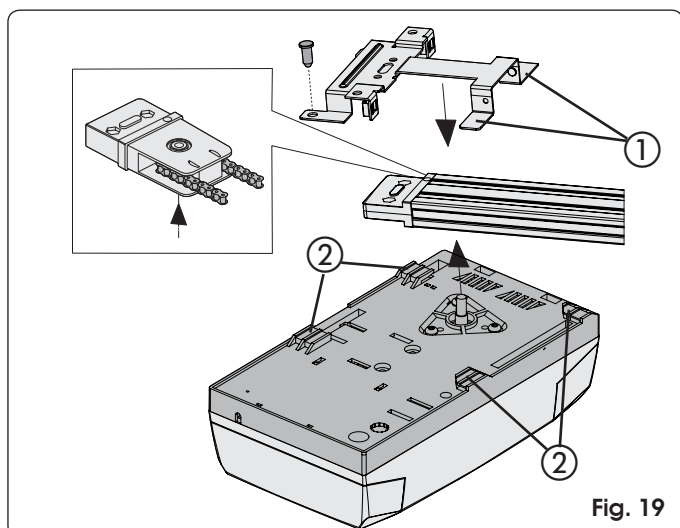

Fig. 19

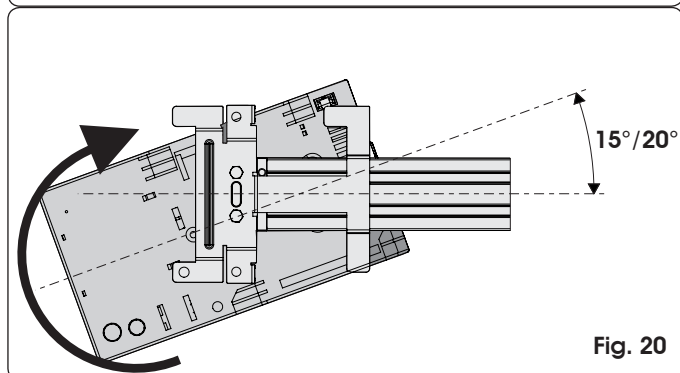

Fig. 20

### 7.4 Releasing the automated system

- 1) Define the height of the release knob, taking into account that it must not be over 180 cm off the ground, and cut off the excess section of rope.
- 2) Make a knot at the end of the rope and assemble the release handle (Fig. 22).
- 3) Pull the release handle down and check if the door can be moved manually (Fig. 22).
- 4) Pull the release handle horizontally in the direction of the door (Fig. 23). Check if, when the handle is released, the LOCK window under the carriage is red. Move the door manually until you find the carriage's hook-on point.

**⚠ Attention: make sure that there are no persons, animals or objects in the door movement area during the release manoeuvre.**

### 7.5 External release

If the automated system has an external release, finish installing (see par. 6.3):

- 1) Cut the cable sheath to size (Fig. 24 ref. A).
- 2) Fit the cable inside the sheath and route it through the eyelet of the door fitting (Fig. 24 ref. B).
- 3) Cut the cable to size and assemble it together to the internal lever of the release handle (Fig. 24 ref. C).

## 8 E600 CONTROL BOARD

### 8.1 Technical specifications

Supply voltage (V ~ / Hz.)	230 / 50
Power supply to accessories (Vdc)	24
Accessories max. load (mA.)	200
Operating ambient temperature (°C)	-20 / +55
Quick-fit connector	for receiver boards XF433 / XF868 and battery module
Operating logics	Automatic / Semiautomatic
Terminal-board connections	Open/Stop/Safety devices/Fail-safe/Flashing lamp 24 Vdc
Courtesy light timer (min.)	2

### 8.2 E600 board components

J1	Low voltage inputs/accessories terminal board
J2	Quick-fit connector for receivers XF433 or XF868
J3	230V power supply input terminal board
J4	Connector for transformer primary winding
J5	Courtesy light terminal-board
J7	Connector for transformer secondary winding
J8	Motor output connector
J12	Battery module connector
OPEN A	Radio signal programming push-button
OPEN B	Radio signal programming push-button
OPEN	OPEN push-button
SETUP	SET-UP push-button
DS1	Programming dip-switch
LD1	Signalling LED: OPEN input
LD2	Signalling LED: STOP input
LD3	Signalling LED: FSW input
LD4	Signalling LED: SET UP cycle
LD5	LED signalling memory-storage: radio channel OPEN A
LD6	LED signalling memory-storage: radio channel OPEN B

### 8.3 Terminal-boards and connectors

Description	Connected device
<b>OPEN A</b>	Command device with N.O. contact (see chap. OPERATING LOGICS)
<b>STOP</b>	Device with N.C. contact which stops the automated system
⊖	Negative for OPEN A and STOP devices
<b>FSW</b>	Closing safety device with N.C. contact (see chap. OPERATING LOGICS)
<b>LAMP</b>	OPEN COLLECTOR 24 Vdc 100 mA. output for flashing lamp
<b>-TX FSW</b>	Negative for powering safety accessories (FAIL SAFE function)
⊖	Negative for powering accessories
⊕	+24 Vdc for powering accessories

### 8.4 DS1 Programming dip-switches

No. Function	OFF	ON
1 Fail Safe	Enabled	Not enabled
2 Anti-crushing sensitivity	Low	High
3 Not used	/	/
4 Carriage speed	High	Low

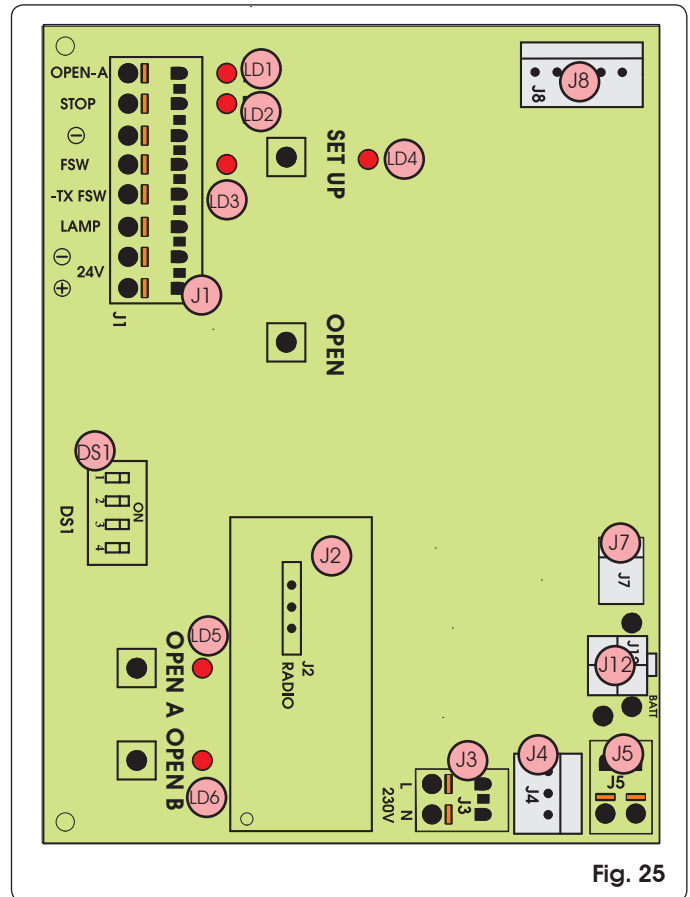

Fig. 25

#### Fail Safe

If activated, it enables the photocell operating test before every movement.

#### Operating logics

For doors with an irregular movement, it reduces the sensitivity of the anti-crushing device to prevent unwanted action by it.

### 8.5 Operating logics

#### Logic A (automatic)

Status	Open (pulse)	Stop	Fsw
CLOSED	Opens and closes after pause time	No effect (2)	No effect
OPENING	No effect	Locks (2)	No effect (1)
OPEN IN PAUSE	Resumes counting of pause time (1)	Locks (1)	Resumes counting of pause time (1)
CLOSING	Reverses motion	Locks (2)	Reverses motion
LOCKED	Closes	No effect (2)	No effect (1)

#### Logic E (semi-automatic)

Status	Open (pulse)	Stop	Fsw
CLOSED	Opens	No effect (2)	No effect
OPENING	Locks	Locks (2)	No effect (1)
OPEN	Closes	No effect (2)	No effect (1)
CLOSING	Reverses motion	Locks (2)	Reverses motion
LOCKED	Closes	No effect (2)	No effect (1)

👉 (1) Prevents closing if pulse is maintained.

👉 (2) Prevents closing and/or opening if pulse is maintained.

 During the opening manoeuvre, the anti-crushing device causes an immediate stop. During the closing manoeuvre, it opens the door.

If, during closure, an obstacle is detected more than three consecutive times, the automated system considers this distance as the new closing contact point and goes into closed status. To restore the correct positions, remove the obstacle and command a new cycle: at the next closure, the automated system will advance at low speed until it detects the contact point.

**9 COURTESY LIGHT**

- The courtesy light stays lighted for 2 minutes after the end of the manoeuvre (cannot be modified).

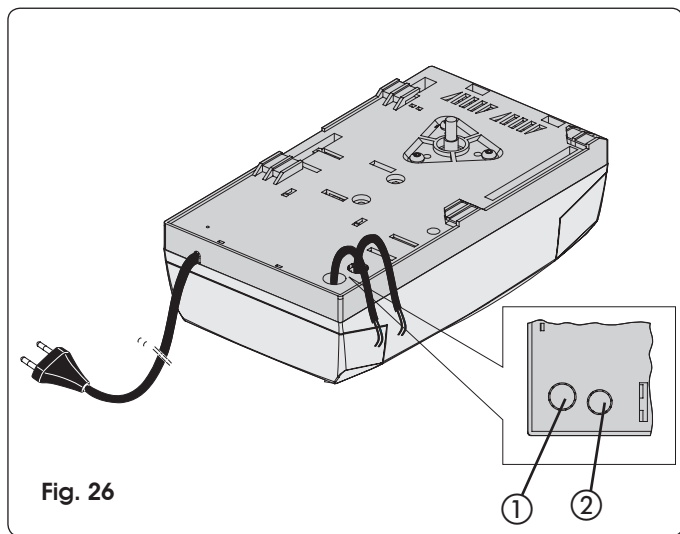



Fig. 26

**10 CONNECTIONS**

**IMPORTANT:** Before attempting any work on the board (connections, maintenance), always cut off power.

- To prevent any electric noise whatever, use separate sheaths for powering the network, signals and accessories.
- The D600 operator has a cable with a two-pole plug for 230 Vac power supply.
- To connect the external controls, safety devices and signals, break open the pre-holed element (Fig. 26 ref. ①).
- To connect the safety edge (see par. 18.3), break open the pre-holed element (Fig. 26 ref. ②).
- Make the electrical connections, referring to Fig. 27.

 If the **STOP** input is not used, jumper connect the input to the terminal  $\ominus$ .  
If the photocells are not used, connect the **FSW** input to terminal **-TX FSW**.

**Input status LEDs**

LD	Meaning	OFF	ON
1	Input status OPEN	Not enabled	Enabled
2	Input status STOP	Enabled	<b>Not Enabled</b>
3	Input status FSW	Safety devices engaged	<b>Safety devices disengaged</b>

 The automated system stopped and at rest is indicated in bold for each input.

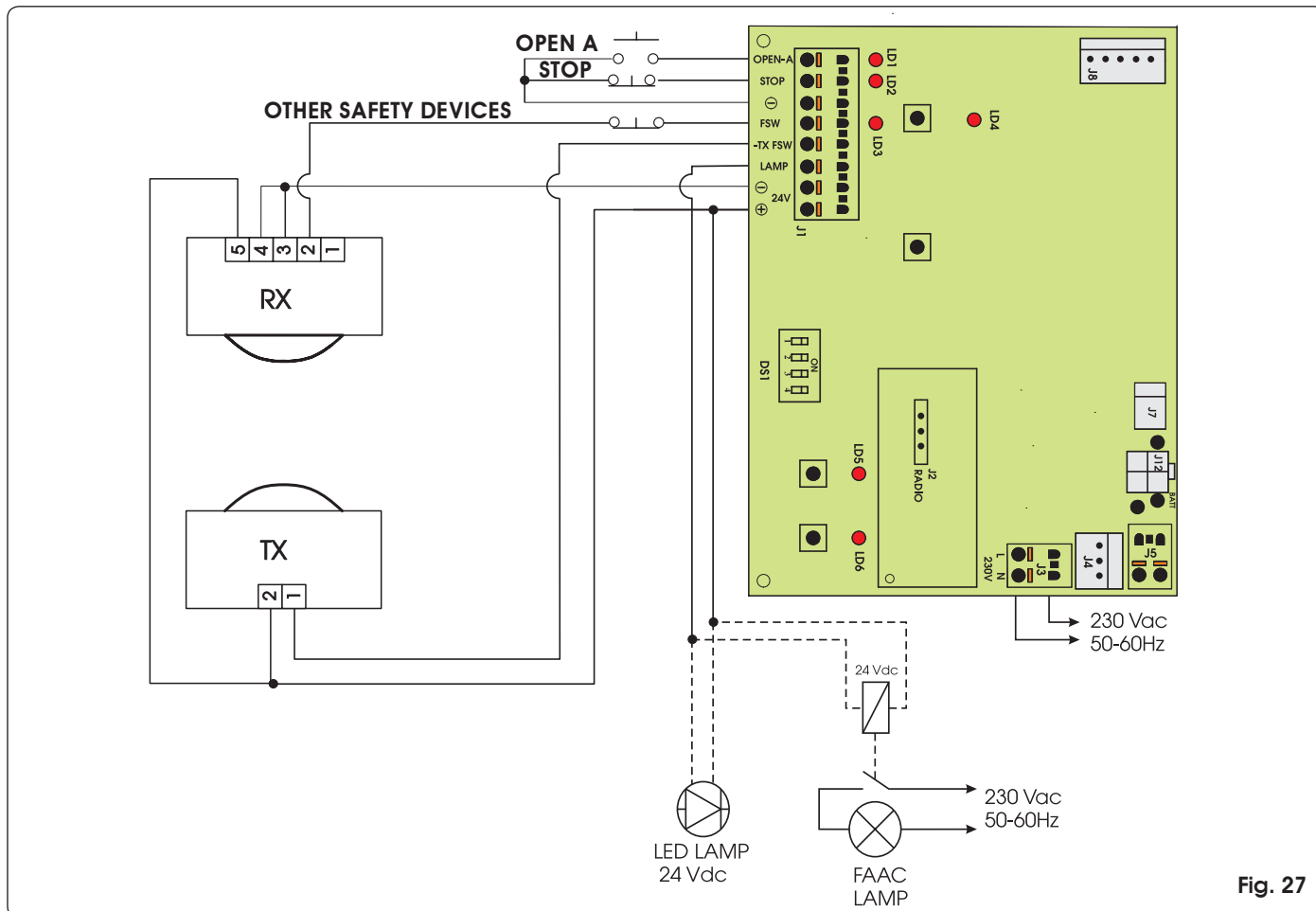

Fig. 27

ENGLISH

## 11 PROGRAMMING

### 11.1 Setting the board

Set the unit with Dip-Switch DS1 to obtain the operation you require.

### 11.2 Learning

**⚠ During the learning procedure, the obstacle detection device does not operate. However, the STOP command and the closing safety devices (FSW) are enabled; if they are triggered, learning is interrupted and a fault is signalled.**

**👉** The SETUP cycle is carried out with the plastic housing installed. Just remove the rear door (Fig. 28). Grip the rear door with both hands and pull gently downward. When you have finished the procedure described in this chapter, put the door back in place.

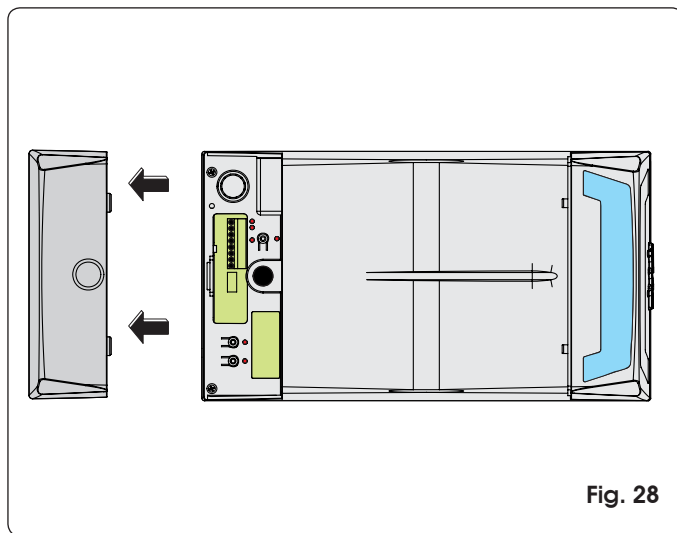

Fig. 28

The learning cycle makes it possible to define the following:

- the force required to move the door.
- the slow-down points.
- the opening and closing stop points.
- the pause time (in automatic logic).

Learning must be started with the operator locked, irrespective of the door's position.

The procedure also determines the operating logic.

The logic tables indicate the behaviour of the automated system in different conditions, and following commands or action by the safety devices.

Learning can be automatic or manual. In the latter case, the opening and closing deceleration points can be determined. However, in automatic mode, the unit independently determines the movement parameters.

If the procedure is not correctly concluded (e.g. due to excessive friction during door movement), the unit signals a fault status (the SET UP LED flashes slowly). In this case, the procedure must be repeated after the cause is eliminated.

### AUTOMATIC LEARNING WITH LOGIC "E" (SEMI-AUTOMATIC)

Press the SET UP push-button for one second.

The SET UP LED starts to flash when you release the push-button.

- 1) After 8 seconds the operator automatically closes the door until the stop point is detected.
- 2) The operator begins the opening movement. Wait until the stop point is reached, or give an OPEN command in the position where you wish to stop motion.
- 3) The operator closes the door.
- 4) Wait for the door to reach the stop point and for the operator to stop.

If the learning procedure terminated positively, the SET UP LED stops flashing and stays lighted for 5 seconds.

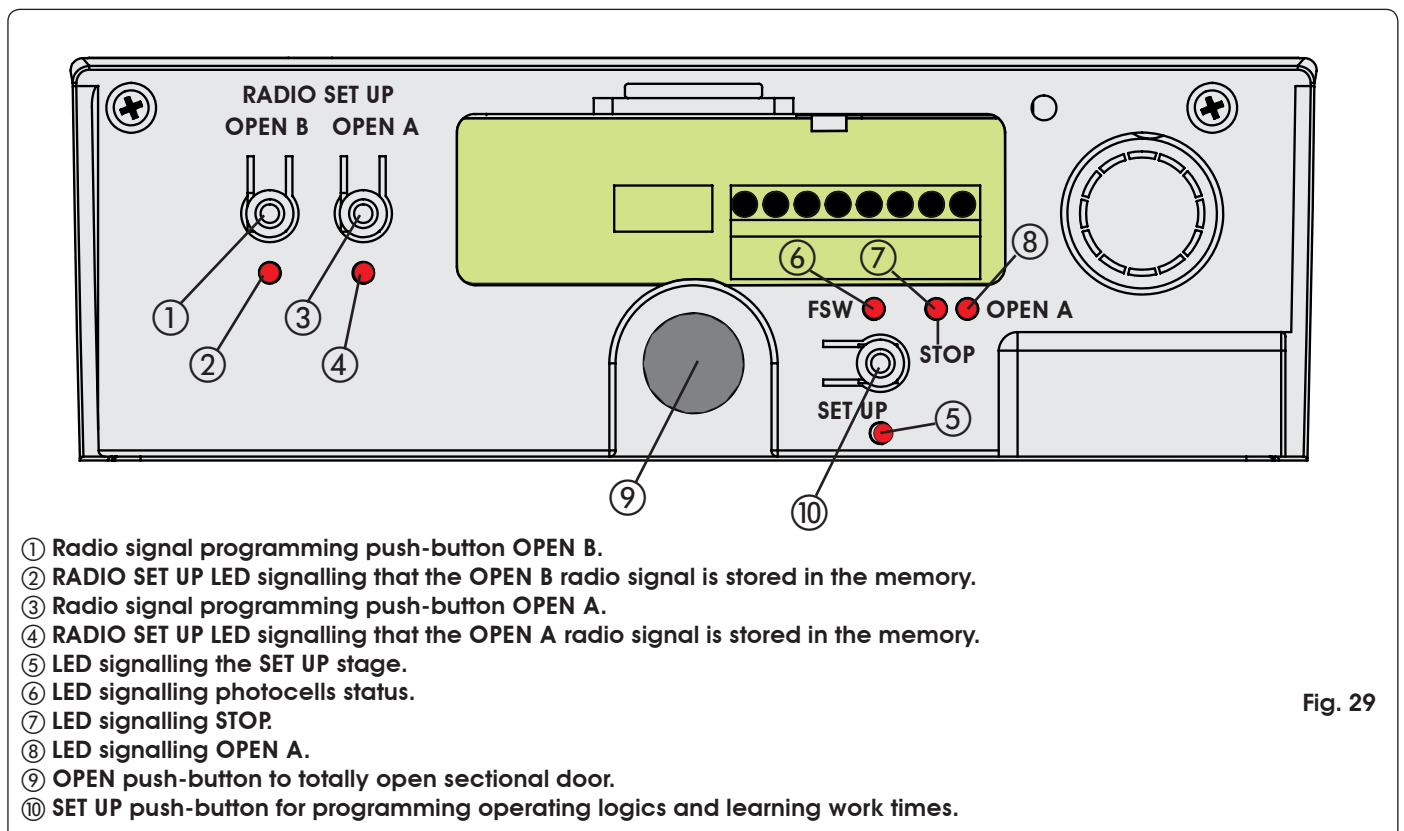

- ① Radio signal programming push-button OPEN B.
- ② RADIO SET UP LED signalling that the OPEN B radio signal is stored in the memory.
- ③ Radio signal programming push-button OPEN A.
- ④ RADIO SET UP LED signalling that the OPEN A radio signal is stored in the memory.
- ⑤ LED signalling the SET UP stage.
- ⑥ LED signalling photocells status.
- ⑦ LED signalling STOP.
- ⑧ LED signalling OPEN A.
- ⑨ OPEN push-button to totally open sectional door.
- ⑩ SET UP push-button for programming operating logics and learning work times.

Fig. 29

During these 5 seconds, in order to lighten the load on the release system, you can send OPEN pulses within a time interval of 2 seconds from each other, in order to reverse the carriage. One pulse corresponds to a 5 millimetre travel.  
N.B.: The carriage can be seen reversing only during normal operation of the automated system.  
The control unit establishes the deceleration points.

**MANUAL LEARNING WITH LOGIC "E" (SEMI-AUTOMATIC)**

Press the SET UP push-button for one second. The SET UP LED starts to flash when you release the push-button. Start the following procedure within 8 seconds (otherwise the operator will perform automatic learning):

- 1) Give the 1st OPEN command: the operator performs a slowed-down closing manoeuvre until it detects the stop point and stops.
- 2) Give the 2nd OPEN command: the operator continues with an opening movement.
- 3) Give the 3rd OPEN command in order to define the point where you wish deceleration to begin.
- 4) Give the 4th OPEN command to define the opening stop point, or wait for the automated system to detect arrival at the stop point and then stop.
- 5) Give the 5th OPEN command: the automated system begins the closing movement.
- 6) Give the 6th OPEN command in order to define the point where you wish deceleration to begin.
- 7) Wait for the door to reach the stop point and for the operator to stop.

If the learning procedure terminated positively, the SET UP LED stops flashing and stays lighted for 5 seconds. During these 5 seconds, in order to lighten the load on the release system, you can send OPEN pulses within a time interval of 2 seconds from each other, in order to reverse the carriage. One pulse corresponds to a 5 millimetre travel.  
N.B.: The carriage can be seen reversing only during normal operation of the automated system.

**AUTOMATIC LEARNING WITH LOGIC "A" (AUTOMATIC)**

Hold down the SET UP push-button until the SET UP LED goes on (about 5 seconds). The SET UP LED starts to flash when you release the push-button.

- 1) After 4 seconds the operator automatically closes the door by deceleration until the stop point is detected.
- 2) The operator moves the door to open. Wait until the stop point is reached, or give an OPEN command in the position where you wish to stop motion.
- 3) The operator closes the door.
- 4) Wait for the door to reach the stop point and for the operator to stop.

If the learning procedure terminated positively, the SET UP LED stops flashing and stays lighted for 5 seconds. During these 5 seconds, in order to lighten the load on the release system, you can send OPEN pulses within a time interval of 2 seconds from each other, in order to reverse the carriage. One pulse corresponds to a 5 millimetre travel.  
N.B.: The carriage can be seen reversing only during normal operation of the automated system.  
The control unit establishes the deceleration points.  
Pause time is fixed at 3 minutes.

**MANUAL LEARNING WITH LOGIC "A" (AUTOMATIC)**

Hold down the SETUP push-button until the SET UP LED goes on (about 5 seconds). The SET UP LED starts to flash when you release the push-button. Start the following procedure within 4 seconds (otherwise the operator will perform automatic SET UP).

- 1) Give the 1st OPEN command: the operator performs a deceleration closing manoeuvre until it detects the stop point.
- 2) Give the 2nd OPEN command: the operator continues with an opening movement.
- 3) Give the 3rd OPEN command in order to define the point where you wish deceleration to begin.
- 4) Give the 4th OPEN command to define the opening stop point, or wait for the automated system to detect arrival at the stop point. After the stop, the time when the automated system is left open starts to be counted. This will be the pause time which will be observed during manual operation (3 minutes maximum).
- 5) Give the 5th OPEN command: the pause time count is stopped and the closing movement starts.
- 6) Give the 6th OPEN command in order to define the point where you wish deceleration to begin.
- 7) Wait for the door to reach the stop point and for the operator to stop.

If the learning procedure terminated positively, the SET UP LED stops flashing and stays lighted for 5 seconds. During these 5 seconds, in order to lighten the load on the release system, you can send OPEN pulses within a time interval of 2 seconds from each other, in order to reverse the carriage. One pulse corresponds to a 5 millimetre travel.  
N.B.: The carriage can be seen reversing only during normal operation of the automated system.

**ON GROUND MANUAL SETTING OF STOP CONTACT POINT (at the learning stage)**

During the learning stage, the operator searches for the on-ground stop point, using the maximum force that can be supplied (600N). To prevent excessive stress, the stop point can be determined also manually: when the automated system performs the closing movements, give an OPEN command when the stop point is reached. If the stop commands at first and second closing were inconsistent, the automated system signals the fault status and the learning cycle must be repeated. During normal operation, the automated system in any case searches for the stop contact point, but it exercises only the force necessary to move the door.



**When the learning cycle has finished, make the automated system perform a complete cycle, in order to acquire the correct closing stop point. If, after the end of this cycle, the automated system opens the door again, command closure.**

**11.3 Pre-flashing**

The pre-flashing function can be enabled and disabled (following an OPEN command, the unit activates the flashing lamp for 5 seconds before it starts the movement).

Procedure:

- 1) Press and hold down the SET UP push-button.
- 2) Press the OPEN push-button too after about 3 seconds. If the SET UP LED goes ON, pre-flashing was activated, if instead, it stays OFF, pre-flashing was disabled.
- 3) Release both push-buttons.



## 12 MEMORY STORAGE OF RADIO CONTROLS CODING

The control unit has an integrated 2-channel decoding system (DS, SLH, LC) named OMNIDEC. This system makes it possible to memory-store both total opening (OPEN A) and partial opening (OPEN B) of the automated system - this is made possible by an additional receiver module (Fig. 30 ref. ①) and radio controls on the same frequency.

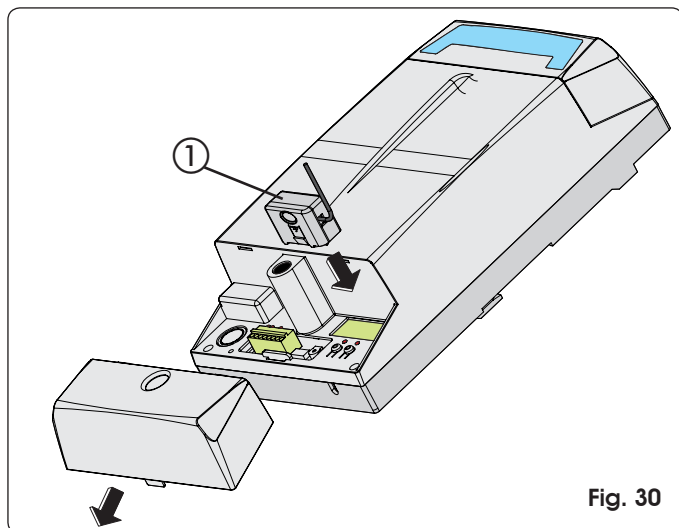

Fig. 30

**The 3 types of radio codes (DS, LSH, LC) cannot coexist. Only one radio code can be used at a time. To change over from one code to another, you must delete the existing one (see paragraph on deletion), and repeat the memory-storage procedure.**

### 12.1 Memory storage of radio controls DS

**A maximum of two codes can be stored. One on the OPEN A channel and one on the OPEN B channel**

- 1) On the DS radio control, select the required ON-OFF combination for the 12 dip-switches.
- 2) To respectively memory store total or partial opening, press the OPEN A or OPEN B push-button for one second (Fig. 31 ref. ②)
- 3) The relevant LED (Fig. 31 ref ①), begins to flash for 5 sec.

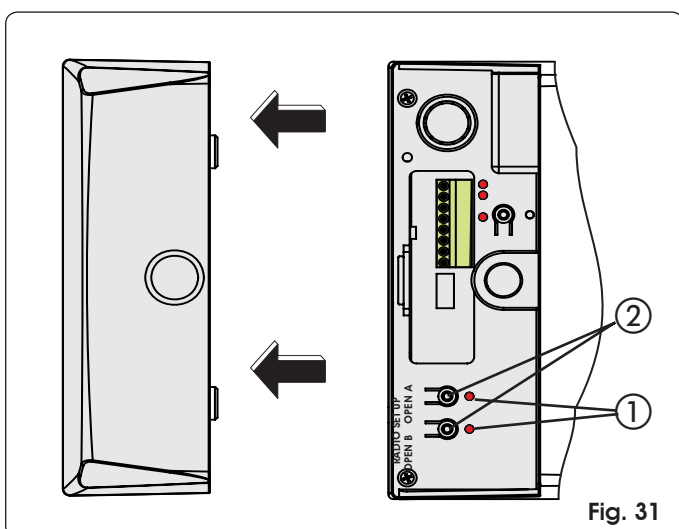

Fig. 31

- 4) Within these 5 secs., press the appropriate push-button on the radio control.
- 5) The relevant LED lights up on steady beam for 1 second and then goes OFF, indicating that storage was executed.
- 6) To add other radio controls, set the same ON - OFF combination used in point 1).

### 12.2 Memory storage of radio controls SLH

**A Maximum of 250 codes can be memory stored, split between OPEN A and OPEN B.**

- 1) On the SLH radio control, simultaneously press and hold down push-buttons P1 and P2.
- 2) The radio control LED begins to flash.
- 3) Release both push-buttons.
- 4) To respectively memory store total or partial opening, press the OPEN A or OPEN B push-button for one second (Fig. 31 ref. ②).
- 5) The relevant LED starts to flash slowly for 5 sec.
- 6) Within these 5 sec., while the radio control LED is still flashing, press and hold down the required push-button on the radio control (the radio control LED lights up on steady beam).
- 7) The LED on the board lights up on steady beam for 1 second and then goes OFF, indicating that storage was executed.
- 8) Release the radio control push-button.
- 9) Quickly press twice in succession the memory stored radio control push-button.

**The automated system performs one opening operation. Make sure that the automated system is free of any obstacle created by persons or things.**

- 10) To add other radio controls, transfer the code of the memory-stored push-button of the radio control to the relevant push-button of the radio controls to be added, observing the following procedure:

- On the memory stored radio control, simultaneously press and hold down push-buttons P1 and P2.
- The radio control LED begins to flash.
- Release both push-buttons.
- Press and hold down the memory-stored push-button (the radio control LED lights up on steady beam).
- Approach the radio controls to each other and hold down the push-button corresponding to the radio control to be added; then release it after a double flash of the radio control LED indicating that storage was executed.
- Quickly press twice in succession the memory stored radio control push-button.

**The automated system performs one opening operation. Make sure that the automated system is free of any obstacle created by persons or things.**

### 12.3 Memory storage of radio controls LC (for some markets only)

**A Maximum of 250 codes can be memory stored, split between OPEN A and OPEN B.**

- 1) Use LC remote controls only with receiver module at 433 MHz.
- 2) To respectively memory store total or partial opening, press the OPEN A or OPEN B push-button for one second (Fig. 31 ref. ②).
- 3) The relevant LED starts to flash slowly for 5 sec.



- 4) Within these 5 secs., press the appropriate push-button on the LC remote control.
- 5) The LED lights up on steady beam for 1 second, indicating memory storage executed, and then resumes flashing for another 5 sec., during which another radio control (point 4) can be memory stored.
- 6) When the 5 secs. have elapsed, the LED goes OFF indicating the end of the procedure.
- 7) To add other radio controls, repeat the operation from point 1).

### 12.3.1 Remote memory storage of LC radio controls

Other radio controls can be remotely stored only with the LC radio controls, i.e. without using the RADIO SETUP push-buttons, but using a previously stored radio control.

- 1) Obtain a radio control already stored on one of the 2 channels (OPEN A or OPEN B).
- 2) Press and simultaneously hold down push-buttons P1 and P2 until the lights of both the LEDs on the board light up.
- 3) Both LEDs flash slowly for 5 sec.
- 4) Within 5 sec. press the push-button of the radio control that had been memory stored to enable learning on the selected channel (OPEN A or OPEN B).
- 5) The LED on the board relating to the channel being learned flashes for 5 sec., within which time the code of another radio control must be transmitted.
- 6) The LED lights up on steady beam for 2 seconds, indicating memory storage executed, and then resumes flashing for 5 sec., during which other radio controls can be memory stored, as in point 5, and then goes OFF.

### 12.4 Radio controls deletion procedure

- 1) To delete **ALL** the radio control codes, hold down push-button OPEN A or OPEN B for 10 sec.
- 2) The LED relating to the pressed push-button flashes for the first 5 sec, and then flashes more quickly for the next 5 sec.
- 3) Both LEDs light up on steady beam for 2 sec and then go OFF.
- 4) Release the pressed push-button when both LEDs light up on a steady beam.



This operation is **NOT** reversible.



All codes of radio controls stored as OPEN A and OPEN B will be deleted.

### 13 START-UP



After installation, make sure that no part of the door interferes with public spaces such as pavements and/or roads.

Check the status of the unit's inputs and make sure that all the safety devices are correctly connected (the relevant LEDs must be lighted).

Run a few complete cycles to check if the automated system and the accessories connected to it are operating correctly, addressing special care to the safety devices and the anti-crushing device of the operator. Check if the automated system is able to detect an obstacle with a height of 50mm laid on the ground.

Apply the stickers indicating the release manoeuvre near the automated system. Apply the danger signal sticker (Fig. 32), so that it is clearly visible, near to the door or near to the control device.

Hand the customer the page entitled "User's guide", and

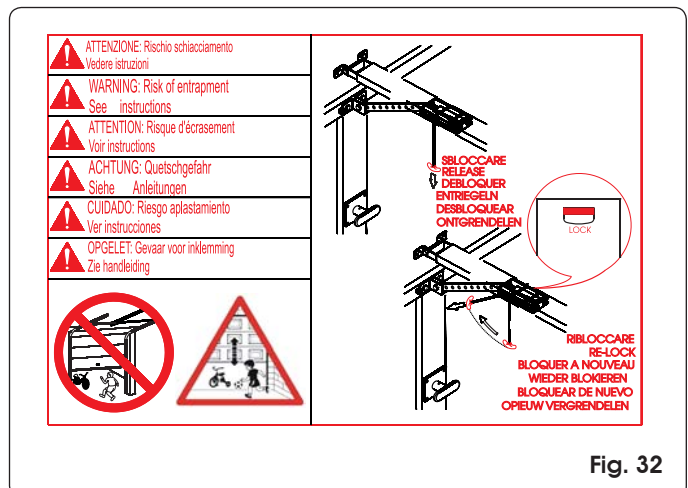

Fig. 32

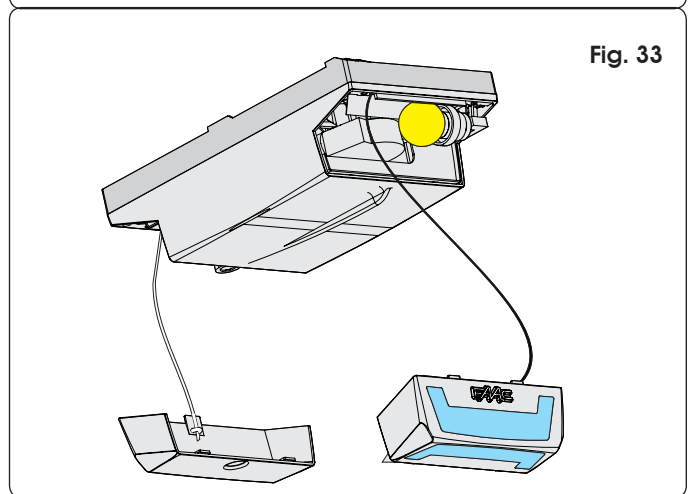

Fig. 33

describe how the system works, and the operator release and locking operations indicated in the guide.

### 14 PARACHUTE CABLES

Connect the parachute cables to the rear door and to the ceiling lamp to prevent accidental falls (Fig. 33).

### 15 MAINTENANCE

Run a functional check of the system at least every 6 months, with special attention to the efficiency of the safety and release devices.

Once a month: check the efficiency of the anti-crushing device and also check if it is able to detect a 50mm high obstacle laid on the ground.

### 16 REPAIRS

For repairs, contact FAAC's authorised Repair Centres.

**17 ACCESSORIES**

**17.1 Central support**

The central support (Fig. 34) provides a central securing point also for the single-piece sliding guide.

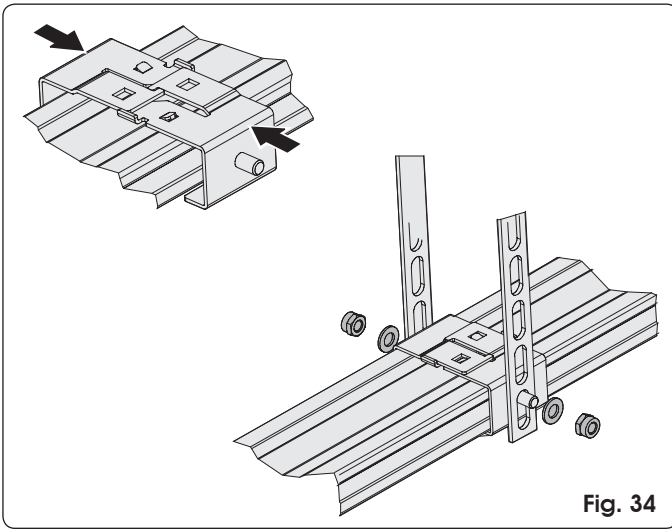

**Fig. 34**

**17.2 Key-operated release**

The external release can be installed with the lever system (Fig. 35 ref. A) or the key system (Fig. 35 ref. B). See instructions in par. 6.3 and par. 7.5.

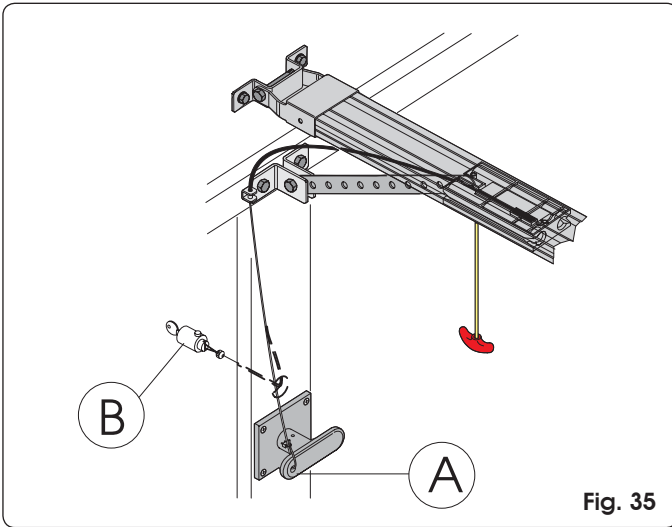

**Fig. 35**

**17.3 Safety edge CN60E**

The use of the safety edge with conductive element, is facilitated because the control unit (Fig. 36 ref ①) can be housed on board the operator.

Procedure:

- Grip the rear door with one hand.
- Pull gently, separating it from the plastic housing.
- Grip the ceiling light with one hand.
- Pull gently, separating it from the plastic housing.
- Unscrew the 4 screws in the 4 corners of the plastic housing.
- Separate it from the base.
- House the control unit as shown in Fig. 36.
- First hook on the two fastening clips on the coupling on the base.
- Then press lightly until you can hear the hooking snap sound.

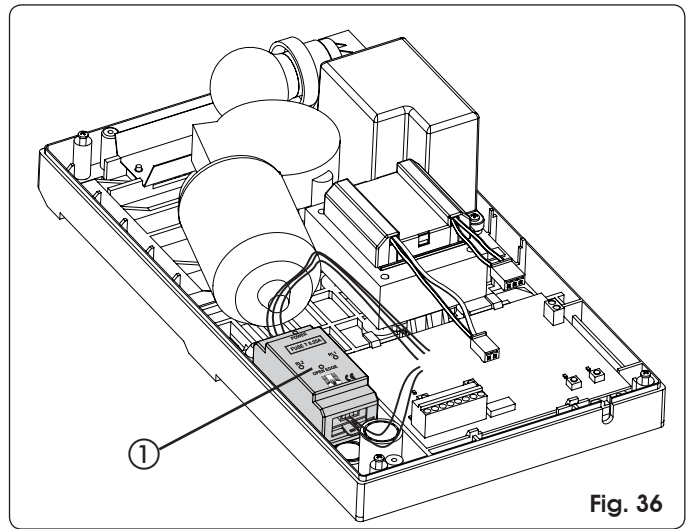

**Fig. 36**

- For the connections, refer to the specific instructions for the CN60E safety edge, and Fig. 27 of these instructions.

**17.4 Battery kit**

The buffer battery kit will activate the automated system in the event of a power cut. The batteries are housed inside the operator (Fig. 37 ref. ①) fastened by a supplied screw. To install, consult the specific instructions.



The batteries come into operation when a power cut occurs.

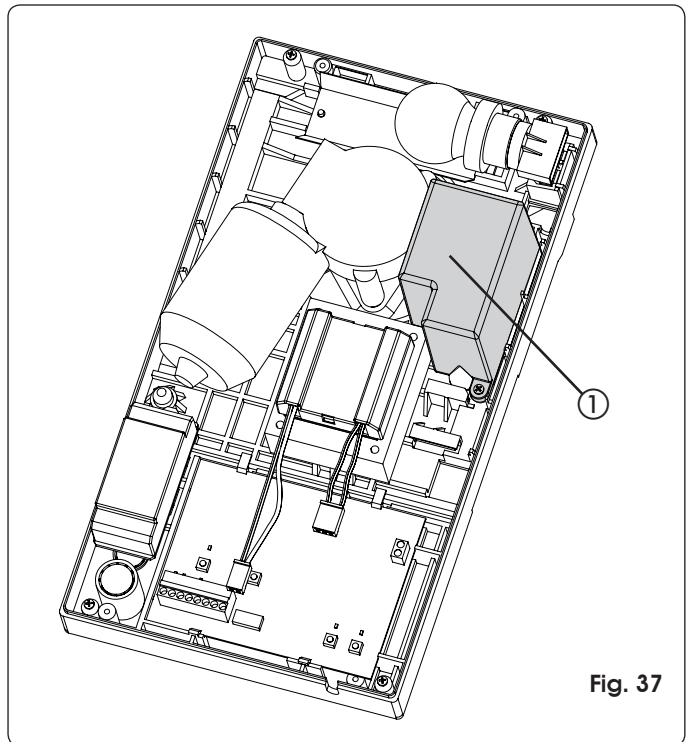

**Fig. 37**



After installing the batteries, connect the male connector to the J12 female connector on the E60 control board.

**18 TROUBLESHOOTING**

ENGLISH

Trouble	Possible causes	Solution
When the learning procedure is started, the SET UP LED flashes but the automated system does not perform any manoeuvre	The STOP and FSW safety devices are enabled also during the learning stage. Non-connection or wrong connection prevents the operator from working	Check the LEDs' status following the instructions of the "Inputs status LEDs". Check the connections shown in fig. 27
The automated system does not perform any movement	STOP command enabled	
	The Fail-Safe function is enabled, but the NC contact of the devices connected to the FSW input does not open during test by the unit before the manoeuvre is started	
The automated system opens the door but does not close it	FSW safety devices engaged	
Learning is not finished correctly and the SET UP LED flashes to signal a fault	The automated system detects that the door movement is too difficult	Check the balance of the door and make sure that it moves without too much friction. Move the door manually, using the rod fitting on the door, and check if the movement is smooth and does not require too much traction or thrust.
The automated system frequently reverses motion during the opening and/or closing manoeuvre		
It is difficult to release the automated system while the door is closed	Too much mechanical load on the release system with the door closed	Run a new learning cycle and, when over, lighten the closing thrust, commanding the carriage to withdraw as described in paragraph 11.2.
The SET UP LED flashes to signal a fault status	The learning cycle did not finish positively.	Run a new learning cycle

**D600 AUTOMATED SYSTEM**

**User's guide**

Read the instructions carefully before using the product and store them for future use.

**GENERAL SAFETY REGULATIONS**

If correctly installed and used, the D600 automated system will ensure a high degree of safety.

Some simple rules on behaviour can prevent accidental trouble:

- Do not, under any circumstances, stand under the door.
- Do not allow persons, animals or things to stay near the automated systems, especially while they are operating.
- Transit must occur while the door is fully open and with the automated system stopped. Keep the door under control during the entire movement and prevent other people accessing the area involved.
- Keep remote-controls, or other pulse generators that could open the door, well away from children.

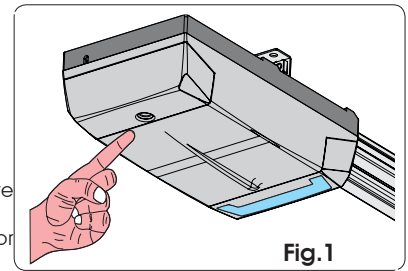

Fig. 1

**- IMPORTANT! DANGER OF CRUSHING.**

- Once a month: check if the anti-crushing system is able to detect the presence of a 50 mm high obstacle laid on the ground.
- Do not allow children to play with the automated system.
- Do not willingly obstruct door movement.
- Prevent any branches or shrubs from interfering with door movement.
- Keep the indicator-lights efficient and easy to see.
- Do not attempt to activate the door by hand unless you have released it.



- In the event of malfunctions, release the door to allow access and wait for qualified technical personnel to do the necessary work.
- When you have set manual operation mode, cut power to the system before restoring normal operation.
- Do not in any way modify the components of the automated system.
- Do not attempt any kind of repair or direct action whatever and contact qualified FAAC personnel only.
- At least every six months: arrange a check by qualified personnel of the automated system and the safety devices.

**DESCRIPTION**

The D600 automated system is ideal to automate balanced sectional doors of single garages for residential use.

The automated systems consist of an electro-mechanical operator, electronic control unit and courtesy light built into a single unit.

The system is non-reversing and, therefore, the door locks mechanically when the motor is not operating and, consequently, no lock is necessary; a manual release makes it possible to move the door in case of a power cut or fault.

The automated system has an electronic obstacle detection system. If an obstacle is detected during the closing manoeuvre, the automated system fully re-opens the door. If the automated system operates in automatic logic, the door re-closes after the pause time, otherwise, a new pulse has to be given to command closure. If an obstacle is detected during the opening manoeuvre, this will stop motion (e.g. thus preventing things and people from being lifted). To restore normal operation, give a new opening pulse.

If, during closure, an obstacle is detected in the same position more than three consecutive times, the automated system considers this distance as the new closing contact point and goes into closed status. To restore the correct positions, remove the obstacle and command a new cycle: at the next closure, the automated system will advance at low speed until it detects the closing contact point.

The door is normally closed; when the control unit receives an opening command by radio control, or from another type of pulse generator (Fig. 1), it activates the electric motor which, by means of a transmission chain or belt, pulls the door open to allow access.

- If the automatic mode was set, the door closes automatically after pause time has elapsed. An opening pulse given during the opening stage has no effect.
- If the semi-automatic mode was set, a second pulse must be sent to close the leaf again.
- An opening pulse supplied during opening, stops movement. An opening pulse given during re-closing, always causes movement to be reversed.
- A stop pulse (if specified) always stops movement.

For details of door activity during the different logics, consult the installation engineer.

Accessories (photocells) may be present in automated systems, that prevent the door from closing when there is an obstacle in the area they control.

Emergency manual opening is possible by using the release system.

The indicator-light (if supplied) indicates the current door movement.

The courtesy light is activated when the motor starts and continues for about 2 minutes after it turns off. If the courtesy light flashes, this means that automated system is in shut-down status due to a fault, and qualified personnel must be called in to repair.

**MANUAL OPERATION**

The D600 operator is equipped with an emergency release system activated from the inside – however, a lock can be fitted on request, for activating the release from the outside too.

If the door has to be moved manually due to a power cut or fault of the automated system, use the release device as follows:

- Turn off electric power to the system.
- Release the operator, by pulling the release handle downward (Fig. 2 ref. A).

**Attention: make sure that there are no persons, animals or objects in the door movement area during the release manoeuvre.**

**RESTORING AUTOMATIC OPERATION MODE**

- Relock the automated system by pulling the handle horizontally (Fig. 2 ref. B) and make sure that, when you release it, the "LOCK" window under the carriage is red, to confirm correct resetting.
- Move the door until you find the hook-on point.
- Power up the system.

**MAINTENANCE**

The D600 automated system does not require any periodic replacement of parts.

**COURTESY LIGHT REPLACEMENT**

To replace the lamp, grip the ceiling light with one hand and pull downward, as shown in Fig. 3. Unscrew the lamp (type E27 - 230 Vac - max 40 W) and re-position the ceiling light.

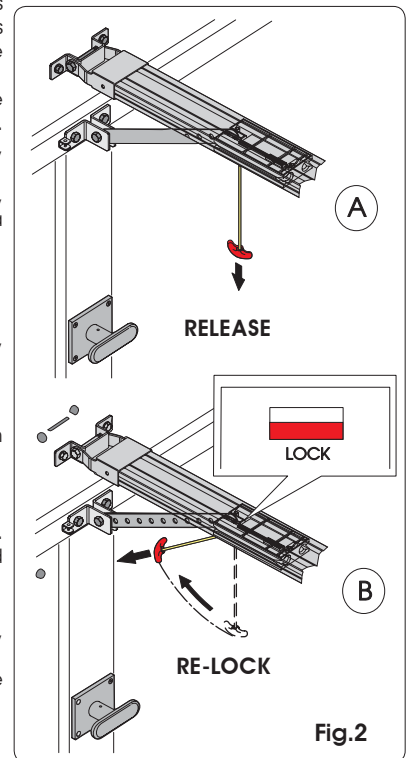

Fig. 2

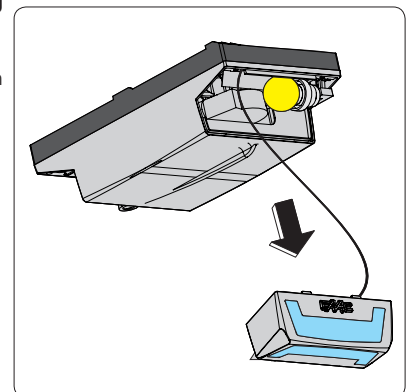
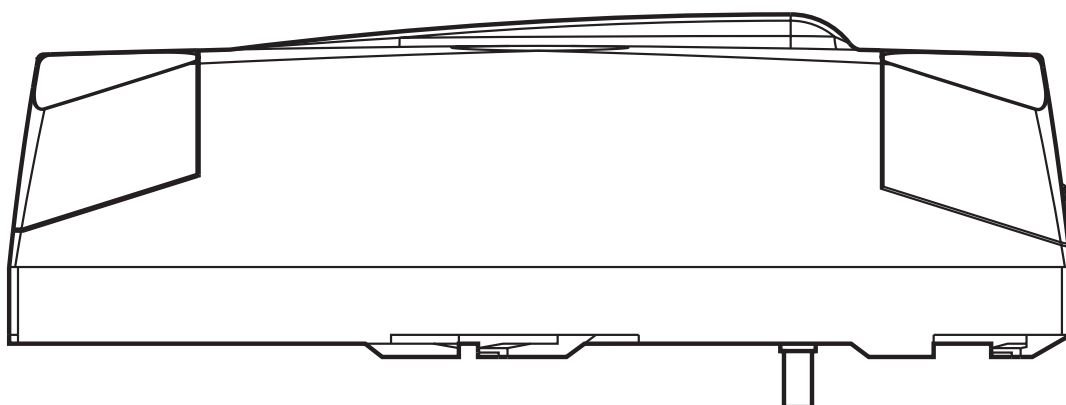
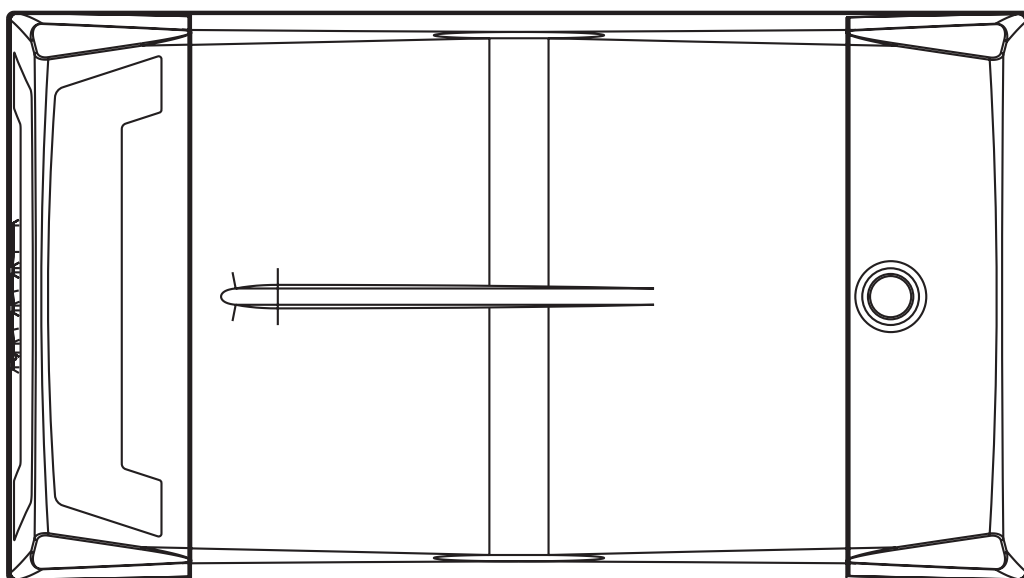

Fig. 3



# D600



**FAAC**





## Guida per l'utente

Leggere attentamente le istruzioni prima di utilizzare il prodotto e conservarle per eventuali necessità future.

### NORME GENERALI DI SICUREZZA

L'automazione D600, se correttamente installata ed utilizzata, garantisce un elevato grado di sicurezza.

Alcune semplici norme di comportamento possono evitare inoltre inconvenienti accidentali:

- Non sostare assolutamente sotto alla porta.
- Non permettere a persone, animali o cose di sostare nelle vicinanze delle automazioni specialmente durante il funzionamento.
- Il transito deve avvenire a porta totalmente aperta e con automazione ferma. Tenere sotto controllo la porta per tutto il movimento ed impedire l'avvicinamento di altre persone all'area interessata.
- Tenere fuori dalla portata dei bambini radiocomandi o qualsiasi altro datore di impulso che possa azionare la porta.

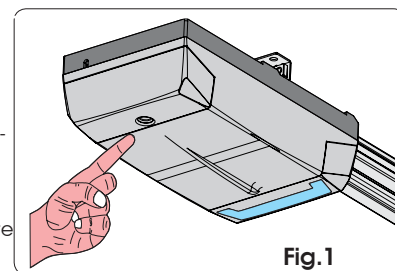

Fig. 1

#### - ATTENZIONE! PERICOLO DI SCHIACCIAMENTO.

- Controllare mensilmente che il sistema antischiacciamento sia in grado di rilevare la presenza di un ostacolo alto 50 mm posto a terra.
- Non permettere a bambini di giocare con l'automazione.
- Non contrastare volontariamente il movimento della porta.
- Evitare che rami o arbusti possano interferire col movimento della porta.
- Mantenere efficienti e ben visibili i sistemi di segnalazione luminosa.
- Non tentare di azionare manualmente la porta se non dopo averla sbloccata.

- In caso di malfunzionamenti, sbloccare la porta per consentire l'accesso ed attendere l'intervento tecnico di personale qualificato.
- Una volta predisposto il funzionamento manuale, prima di ripristinare il funzionamento normale, togliere alimentazione elettrica all'impianto.
- Non eseguire alcuna modifica sui componenti facenti parte del sistema di automazione.
- Astenersi da qualsiasi tentativo di riparazione o d'intervento diretto e rivolgersi solo a personale qualificato FAAC.
- Far verificare almeno semestralmente l'efficienza dell'automazione, dei dispositivi di sicurezza da personale qualificato.

### DESCRIZIONE

L'automazione D600 è ideale per automatizzare porte sezionali bilanciate di garages singoli residenziali.

Le automazioni sono costituite da un operatore elettromeccanico, un'apparecchiatura elettronica di controllo, una lampada di cortesia e un carter di protezione integrati in un unico monoblocco.

Il sistema irreversibile garantisce il blocco meccanico della porta quando il motore non è in funzione e quindi non occorre installare alcuna serratura; uno sblocco manuale rende manovrabile la porta in caso di black-out o disservizio.

L'automazione è dotata di un sistema elettronico per il rilevamento di ostacolo. Se viene rilevato un ostacolo durante la manovra di chiusura, l'automazione riapre completamente la porta. Se l'automazione funziona in logica automatica, la porta si richiuderà dopo il tempo di pausa, in caso contrario occorrerà dare un nuovo impulso per comandare la chiusura. Durante la manovra di apertura, la rilevazione di un ostacolo causa l'arresto del moto (ciò ad evitare sollevamento di cose o persone). Per ripristinare il normale funzionamento occorre dare un nuovo impulso di apertura.

Se viene rilevato un ostacolo in chiusura nella stessa posizione per tre volte consecutive, l'automazione assume tale quota come nuova battuta di chiusura e si pone in stato di chiuso. Per ripristinare le corrette posizioni, rimuovere l'ostacolo e comandare un nuovo ciclo: alla successiva chiusura l'automazione avanzerà a velocità rallentata fino ad individuare la battuta.

La porta normalmente si trova chiusa; quando la centralina elettronica riceve un comando di apertura tramite il radiocomando, o qualsiasi altro datore di impulso (Fig. 1), aziona il motore elettrico che tramite trasmissione a catena od a cinghia trascina il portone in posizione di apertura e consente l'accesso.

- Se è stato impostato il funzionamento automatico, la porta si richiude da sola dopo il tempo pausa.

Un impulso di apertura dato durante la fase di apertura non ha nessun effetto.

- Se è stato impostato il funzionamento semiautomatico, è necessario inviare un secondo impulso per ottenere la richiusura.

- Un impulso di apertura dato durante la fase di apertura provoca l'arresto del movimento. Un impulso di apertura dato durante la fase di richiusura provoca sempre l'inversione del movimento.

- Un impulso di stop (se previsto) arresta sempre il movimento.

Per il dettagliato comportamento della porta nelle diverse logiche fare riferimento al Tecnico installatore.

Nelle automazioni possono essere presenti accessori (fotocellule) che impediscono la richiusura della porta quando un ostacolo si trova nella zona da essi controllata.

L'apertura manuale d'emergenza è possibile intervenendo sull'apposito sistema di sblocco.

La segnalazione luminosa (se prevista) indica il movimento in atto della porta.

La luce di cortesia si attiva alla partenza del motore e permane per un tempo di circa 2 minuti dal suo spegnimento. Se la lampada di cortesia lampeggia, l'automazione è in stato di blocco per anomalia ed occorre richiedere l'intervento di personale qualificato per la riparazione.

### FUNZIONAMENTO MANUALE

L'operatore D600 è dotato di un sistema di sblocco di emergenza azionabile dall'interno; è possibile, a richiesta, applicare una serratura che permetta l'azionamento dello sblocco anche dall'esterno.

Nel caso sia necessario azionare la porta a causa di mancanza di alimentazione elettrica o disservizio dell'automazione è necessario agire sul dispositivo di sblocco come segue:

- Togliere l'alimentazione elettrica all'impianto.
- Sbloccare l'operatore tirando verso il basso la maniglia di sblocco (Fig. 2 rif. A).

**Attenzione: evitare che persone, animali od oggetti si trovino nella zona di movimento della porta durante la manovra di sblocco.**

### RIPRISTINO DEL FUNZIONAMENTO AUTOMATICO

- Ribloccare l'automazione tirando orizzontalmente la maniglia (Fig. 2 rif. B) ed accertarsi che, al rilascio, la finestrella "LOCK" posta sotto al carrello sia di colore rosso, a conferma del corretto riarmo.
- Muovere la porta fino a ritrovare il punto di aggancio.
- Alimentare nuovamente l'impianto.

### MANUTENZIONE

L'automazione D600 non richiede alcuna sostituzione periodica di parti.

### SOSTITUZIONE LAMPADA DI CORTESIA

Per la sostituzione della lampada, afferrare con una mano la plafoniera e tirare verso il basso, come indicato in Fig. 3.

Svitare la lampada (tipo E27 - 230 Vac - max 40 W) e riposizionare la plafoniera.

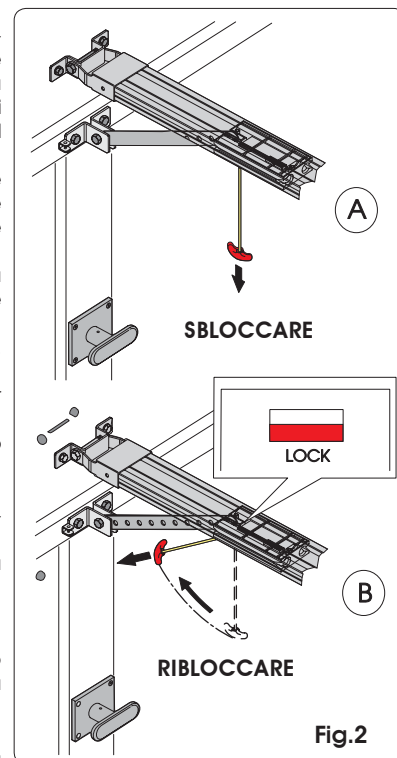

Fig. 2

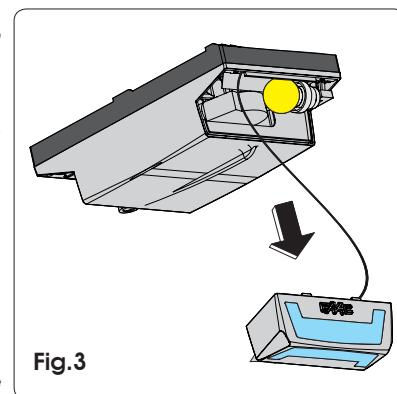

Fig. 3

## REGISTRO DI MANUTENZIONE

### Dati impianto

Installatore	
Cliente	
Tipo impianto	
Matricola	
Data installazione	
Attivazione	

### Configurazione impianto

COMPONENTE	MODELLO	MATICOLA
Operatore		
Dispositivo di sicurezza 1		
Dispositivo di sicurezza 2		
Coppia fotocellule 1		
Coppia fotocellule 2		
Dispositivo di comando 1		
Dispositivo di comando 2		
Radiocomando		
Lampeggiante		

### Indicazione dei rischi residui e dell'uso improprio prevedibile

Nr	Data	Descrizione intervento	Firme
1			Tecnico Cliente
2			Tecnico Cliente
3			Tecnico Cliente
4			Tecnico Cliente
5			Tecnico Cliente
6			Tecnico Cliente
7			Tecnico Cliente
8			Tecnico Cliente
9			Tecnico Cliente
10			Tecnico Cliente

**D600 AUTOMATED SYSTEM**

**User's guide**

Read the instructions carefully before using the product and store them for future use.

**GENERAL SAFETY REGULATIONS**

If correctly installed and used, the D600 automated system will ensure a high degree of safety.

Some simple rules on behaviour can prevent accidental trouble:

- Do not, under any circumstances, stand under the door.
- Do not allow persons, animals or things to stay near the automated systems, especially while they are operating.
- Transit must occur while the door is fully open and with the automated system stopped. Keep the door under control during the entire movement and prevent other people accessing the area involved.
- Keep remote-controls, or other pulse generators that could open the door, well away from children.

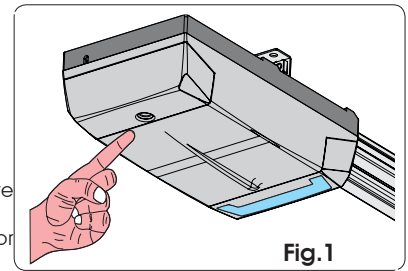

Fig.1

**- IMPORTANT! DANGER OF CRUSHING.**

- Once a month: check if the anti-crushing system is able to detect the presence of a 50 mm high obstacle laid on the ground.
- Do not allow children to play with the automated system.
- Do not willingly obstruct door movement.
- Prevent any branches or shrubs from interfering with door movement.
- Keep the indicator-lights efficient and easy to see.
- Do not attempt to activate the door by hand unless you have released it.



- In the event of malfunctions, release the door to allow access and wait for qualified technical personnel to do the necessary work.
- When you have set manual operation mode, cut power to the system before restoring normal operation.
- Do not in any way modify the components of the automated system.
- Do not attempt any kind of repair or direct action whatever and contact qualified FAAC personnel only.
- At least every six months: arrange a check by qualified personnel of the automated system and the safety devices.

**DESCRIPTION**

The D600 automated system is ideal to automate balanced sectional doors of single garages for residential use.

The automated systems consist of an electro-mechanical operator, electronic control unit and courtesy light built into a single unit.

The system is non-reversing and, therefore, the door locks mechanically when the motor is not operating and, consequently, no lock is necessary; a manual release makes it possible to move the door in case of a power cut or fault.

The automated system has an electronic obstacle detection system. If an obstacle is detected during the closing manoeuvre, the automated system fully re-opens the door. If the automated system operates in automatic logic, the door re-closes after the pause time, otherwise, a new pulse has to be given to command closure. If an obstacle is detected during the opening manoeuvre, this will stop motion (e.g. thus preventing things and people from being lifted). To restore normal operation, give a new opening pulse.

If, during closure, an obstacle is detected in the same position more than three consecutive times, the automated system considers this distance as the new closing contact point and goes into closed status. To restore the correct positions, remove the obstacle and command a new cycle: at the next closure, the automated system will advance at low speed until it detects the closing contact point.

The door is normally closed; when the control unit receives an opening command by radio control, or from another type of pulse generator (Fig. 1), it activates the electric motor which, by means of a transmission chain or belt, pulls the door open to allow access.

- If the automatic mode was set, the door closes automatically after pause time has elapsed. An opening pulse given during the opening stage has no effect.
- If the semi-automatic mode was set, a second pulse must be sent to close the leaf again.
- An opening pulse supplied during opening, stops movement. An opening pulse given during re-closing, always causes movement to be reversed.
- A stop pulse (if specified) always stops movement.

For details of door activity during the different logics, consult the installation engineer.

Accessories (photocells) may be present in automated systems, that prevent the door from closing when there is an obstacle in the area they control.

Emergency manual opening is possible by using the release system.

The indicator-light (if supplied) indicates the current door movement.

The courtesy light is activated when the motor starts and continues for about 2 minutes after it turns off. If the courtesy light flashes, this means that automated system is in shut-down status due to a fault, and qualified personnel must be called in to repair.

**MANUAL OPERATION**

The D600 operator is equipped with an emergency release system activated from the inside – however, a lock can be fitted on request, for activating the release from the outside too.

If the door has to be moved manually due to a power cut or fault of the automated system, use the release device as follows:

- Turn off electric power to the system.
- Release the operator, by pulling the release handle downward (Fig. 2 ref. A).

**Attention: make sure that there are no persons, animals or objects in the door movement area during the release manoeuvre.**

**RESTORING AUTOMATIC OPERATION MODE**

- Relock the automated system by pulling the handle horizontally (Fig. 2 ref. B) and make sure that, when you release it, the "LOCK" window under the carriage is red, to confirm correct resetting.
- Move the door until you find the hook-on point.
- Power up the system.

**MAINTENANCE**

The D600 automated system does not require any periodic replacement of parts.

**COURTESY LIGHT REPLACEMENT**

To replace the lamp, grip the ceiling light with one hand and pull downward, as shown in Fig. 3. Unscrew the lamp (type E27 - 230 Vac - max 40 W) and re-position the ceiling light.

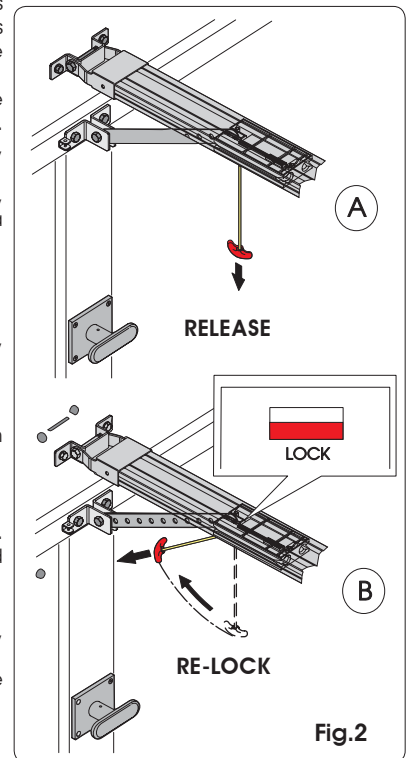

Fig.2

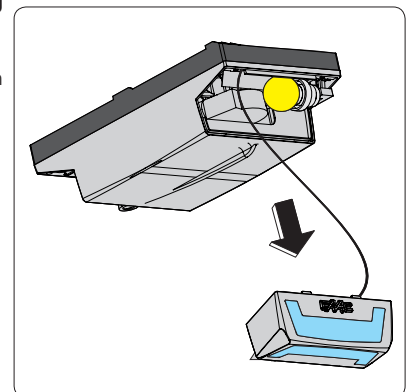

Fig.3

# MAINTENANCE REGISTER

## System data

<i>Installer</i>	
<i>Customer</i>	
<i>Type of system</i>	
<i>Serial No.</i>	
<i>Installation date</i>	
<i>Start-up</i>	

## System configuration

PART	MODEL	SERIAL NUMBER
Operator		
Safety device 1		
Safety device 2		
Pair of photocells 1		
Pair of photocells 2		
Control device 1		
Control device 2		
Radio control		
Flashing lamp		

## Indication of residual risks and of foreseeable improper use

No.	Date	Job description	Signatures
1			Technician Customer
2			Technician Customer
3			Technician Customer
4			Technician Customer
5			Technician Customer
6			Technician Customer
7			Technician Customer
8			Technician Customer
9			Technician Customer
10			Technician Customer

## AUTOMATISME D600

### Instructions pour l'utilisateur

Lire attentivement les instructions avant d'utiliser le produit et les conserver pour toute nécessité future éventuelle.

#### RÈGLES GÉNÉRALES DE SÉCURITÉ

S'il est correctement installé et utilisé, l'automatisme D600 garantit un haut niveau de sécurité.

Par ailleurs, quelques règles simples de comportement peuvent éviter bien des accidents:

- Ne jamais stationner sous la porte.
- Ne pas permettre aux personnes, aux animaux ou aux choses de stationner à proximité des automatismes en particulier durant le fonctionnement.
- Ne pas transiter que lorsque la porte est totalement ouverte et que l'automatisme est arrêté. Contrôler la porte durant tout le mouvement et empêcher d'autres personnes de s'approcher de la zone concernée.
- Éloigner de la portée des enfants: les radiocommandes ou tout autre dispositif générateur d'impulsion en mesure d'actionner la porte.

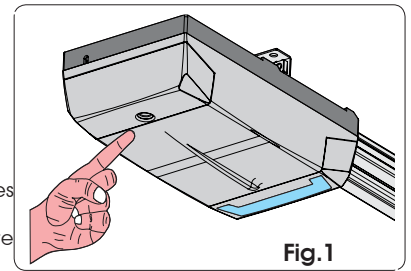

Fig. 1



#### - ATTENTION! DANGER D'ÉCRASEMENT.

- Contrôler tous les mois que le système anti-écrasement est en mesure de détecter la présence d'un obstacle d'une hauteur de 50 mm placé au sol.
- Interdire aux enfants de jouer avec l'automatisme.
- Ne pas contraster volontairement le mouvement de la porte.
- Éviter que des branches ou des arbustes n'entravent le mouvement de la porte.
- Faire en sorte que les systèmes de signalisation lumineuse soient toujours efficaces et bien visibles.
- N'actionner manuellement la porte qu'après l'avoir déverrouillée.
- En cas de dysfonctionnement, déverrouiller la porte pour permettre l'accès et attendre l'intervention technique du personnel qualifié.
- Lorsque le fonctionnement manuel a été disposé, couper le courant sur l'installation avant de rétablir le fonctionnement normal.
- N'effectuer aucune modification sur les composants qui font partie du système d'automatisme.
- Éviter toute tentative de réparation ou d'intervention directe et s'adresser uniquement à du personnel qualifié FAAC.
- Faire vérifier, au moins tous les six mois, l'efficacité de l'automatisme, des dispositifs de sécurité par du personnel qualifié.

#### DESCRIPTION

L'automatisme D600 est l'idéal pour automatiser les portes sectionnelles équilibrées de garages individuels domestiques.

Les automatismes sont constitués par un opérateur électromagnétique, une armoire électronique de contrôle, une lampe de courtoisie et un carter de protection intégrés en un seul monobloc.

Le système irréversible garantit le blocage mécanique de la porte quand le moteur n'est pas en fonction; il n'est donc pas nécessaire d'installer de serrure; un déverrouillage manuel permet de manœuvrer la porte en cas de coupure de courant ou de dysfonctionnement.

L'automatisme est équipé d'un système électronique de détection d'obstacles. Si un obstacle est détecté durant la manœuvre de fermeture, l'automatisme rouvre complètement la porte. Si l'automatisme fonctionne en logique automatique, la porte se referme à la fin du temps de pause; dans le cas contraire, donner une nouvelle impulsion pour commander la fermeture. Durant la manœuvre d'ouverture, la détection d'un obstacle provoque l'arrêt du mouvement (pour éviter le soulèvement de choses ou de personnes). Pour rétablir le fonctionnement normal, donner une nouvelle impulsion d'ouverture.

Si un obstacle est détecté en fermeture dans la même position trois fois de suite, l'automatisme considère cette cote comme une nouvelle butée de fermeture et se met en état de fermé. Pour rétablir les positions correctes, enlever l'obstacle et commander un nouveau cycle: à la fermeture successive, l'automatisme avancera à une vitesse ralentie jusqu'à l'identification de la butée.

La porte est normalement fermée; quand la centrale électronique reçoit une commande d'ouverture par l'intermédiaire de la radiocommande ou de tout autre générateur d'impulsions (Fig. 1), elle actionne le moteur électrique qui, par l'intermédiaire de la transmission à chaîne ou à courroie entraîne la porte en position d'ouverture et permet l'accès.

- Si l'on a sélectionné le fonctionnement automatique, la porte se referme d'elle-même après le temps de pause. Une impulsion d'ouverture donnée durant la phase d'ouverture n'a aucun effet.
- Si l'on a sélectionné le fonctionnement semi-automatique, envoyer une deuxième impulsion pour obtenir la refermeture.
- Une impulsion d'ouverture donnée durant la phase d'ouverture provoque l'arrêt du mouvement. Une impulsion d'ouverture donnée durant la phase de refermeture provoque l'inversion du mouvement.
- Une impulsion de stop (si elle est prévue) arrête toujours le mouvement.

Pour le comportement détaillé de la porte dans les différentes logiques, s'adresser au Technicien installateur.

Les automatismes peuvent présenter des accessoires (photocellules) empêchant la refermeture de la porte en présence d'un obstacle dans la zone qu'ils contrôlent.

L'ouverture manuelle d'urgence est possible en intervenant sur le système de déverrouillage spécifique.

La signalisation lumineuse (si elle est prévue) indique que la porte est en mouvement.

La lampe de courtoisie s'allume au démarrage du moteur et reste allumée pendant une durée d'environ 2 minutes après son extinction. Si la lampe de courtoisie clignote, l'automatisme est en état de blocage dû à une anomalie; il faut donc demander l'intervention du personnel qualifié pour la réparation.

#### FONCTIONNEMENT MANUEL

L'opérateur D600 est équipé d'un système de déverrouillage d'urgence à actionner de l'intérieur; sur demande, on peut appliquer une serrure permettant également l'actionnement du déverrouillage de l'extérieur.

S'il est nécessaire d'actionner la porte en raison d'une coupure de courant ou d'un dysfonctionnement de l'automatisme, agir sur le dispositif de déverrouillage comme suit:

- Couper le courant électrique sur l'installation.
- Déverrouiller l'opérateur en tirant la poignée de déverrouillage vers le bas (Fig. 2 réf. A).

**Attention: éviter que des personnes, des animaux ou des objets ne se trouvent dans la zone de mouvement de la porte durant la manœuvre de déverrouillage.**

#### RÉTABLISSEMENT DU FONCTIONNEMENT AUTOMATIQUE

- Bloquer de nouveau l'automatisme en tirant la poignée horizontalement (Fig. 2 réf. B) et s'assurer qu'à la relâchement, la fenêtre "LOCK" sous le chariot est de couleur rouge, confirmant le réarmement correct.
- Actionner la porte pour retrouver le point d'accrochage.
- Remettre l'installation sous tension.

#### ENTRETIEN

L'automatisme D600 n'exige pas le remplacement périodique de pièces.

#### REMPLACEMENT DE LA LAMPE DE COURTOISIE

Pour le remplacement de l'ampoule, saisir le plafonnier d'une main et tirer vers le bas, d'après la Fig. 3. Dévisser l'ampoule (type E27 - 230 Vca - 40 W maxi) et remettre le plafonnier en place.

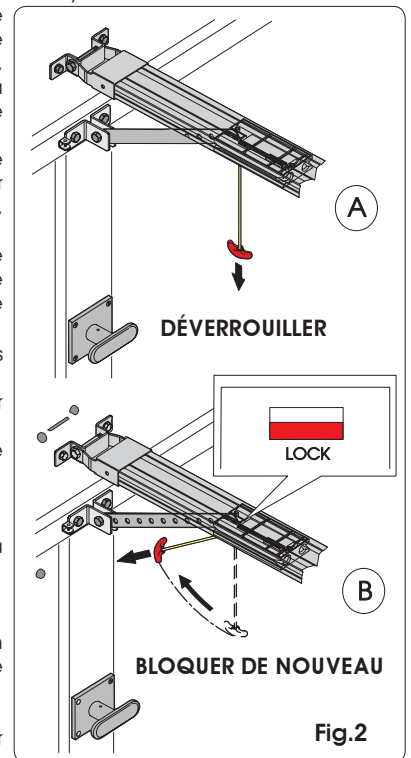

Fig. 2

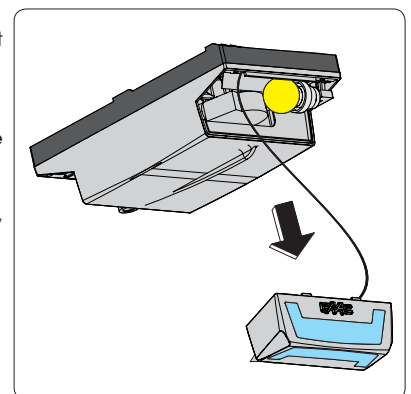

Fig. 3



# REGISTRE D'ENTRETIEN

## Données de l'installation

<i>Installateur</i>	
<i>Client</i>	
<i>Type d'installation</i>	
<i>N° de série</i>	
<i>Date d'installation</i>	
<i>Activation</i>	

## Configuration de l'installation

COMPOSANT	MODÈLE	N° DE SERIE
Opérateur		
Dispositif de sécurité 1		
Dispositif de sécurité 2		
Paire de photocellules 1		
Paire de photocellules 2		
Dispositif de commande 1		
Dispositif de commande 2		
Radiocommande		
Lampe clignotante		

## Indication des risques résiduels et de l'usage impropre prévisible

N°	Date	Description de l'intervention	Signatures
1			Technicien Client
2			Technicien Client
3			Technicien Client
4			Technicien Client
5			Technicien Client
6			Technicien Client
7			Technicien Client
8			Technicien Client
9			Technicien Client
10			Technicien Client

**AUTOMATION D600**

**Anleitungen für den Benutzer**

Vor der Verwendung des Produkts sind die Anweisungen aufmerksam zu lesen und dann für den eventuellen zukünftigen Bedarf aufzubewahren.

**ALLGEMEINE SICHERHEITSVORSCHRIFTEN**

Bei korrekter Installation und sachgemäßer Anwendung gewährleistet die Automation D600 ein hohes Sicherheitsniveau.

Einige einfache Verhaltensregeln können außerdem ungewollte Störungen vermeiden:

- Auf keinen Fall unter dem Tor aufhalten.
- Personen, Tiere oder Dinge dürfen sich nicht in der Nähe der Automationen, insbesondere während des Betriebs, befinden.
- Der Durchgang bzw. die Durchfahrt muss bei vollständig geöffnetem Tor und stillstehender Automation erfolgen. Das Tor während der gesamten Bewegung kontrollieren und verhindern, dass andere Personen sich dem betreffenden Bereich nähern.
- Funksteuerungen oder andere Impulsgeber, die das Tor betätigen können, sind außerhalb der Reichweite von Kindern aufzubewahren.



**- ACHTUNG! QUETSCHGEFAHR.**

- Monatlich überprüfen, ob das Quetschschutzsystem in der Lage ist, ein 50 mm hohes, auf dem Boden liegendes Hindernis zu erfassen.
- Kinder dürfen nicht mit der Automation spielen.
- Die Bewegung des Tors darf nicht absichtlich behindert werden.
- Vermeiden, dass Zweige oder Büsche die Bewegung des Tors beeinträchtigen.

- Darauf achten, dass die Leuchtsignalsysteme stets funktionstüchtig und gut sichtbar sind.
- Das Tor darf nur dann mit der Hand betätigt werden, wenn es entriegelt wurde.
- Bei Betriebsstörungen das Tor mit der Hand entriegeln, um den Zutritt/die Zufahrt zu ermöglichen und technische Fachkräfte benachrichtigen.
- Wenn der Handbetrieb eingestellt ist, muss vor der Wiederherstellung des Normalbetriebs die Stromzufuhr zur Anlage unterbrochen werden.
- Keine Änderungen an den Bauteilen des Automationssystems vornehmen.
- Keine Reparaturen oder direkten Arbeiten selbst ausführen und sich nur an Fachtechniker der Firma FAAC wenden.
- Im Abstand von mindestens 6 Monaten die Funktionstüchtigkeit der Automation, der Sicherheitsvorrichtungen von Fachkräften prüfen lassen.

**BESCHREIBUNG**

Die Automation D600 ist ideal für die Automatisierung von ausgeglichenen Sektionaltoren von Einzelgaragen in Wohngebäuden. Die Automationen bestehen aus einem elektromechanischen Antrieb, einem elektronischen Steuergerät, einer Servicelampe und einem Schutzgehäuse, die in ein einziges Kompaktteil integriert sind.

Das irreversible System gewährleistet die mechanische Verriegelung des Tors, wenn der Motor nicht läuft, daher muss kein Schloss eingebaut werden. Durch eine manuelle Entriegelung kann das Tor bei Stromausfall oder Betriebsstörungen bewegt werden.

Die Automation ist mit einem elektronischen System für die Hinderniserfassung ausgerüstet. Wenn ein Hindernis während des Schließens erfasst wird, öffnet die Automation erneut vollständig das Tor. Wenn der Automatikbetrieb eingestellt wurde, schließt sich das Tor nach einer Pausenzeit, anderenfalls ist ein neuer Impuls für die Steuerung des Schließvorgangs erforderlich. Während des Öffnens verursacht die Erfassung eines Hindernisses den Stillstand der Bewegung (dies geschieht um zu vermeiden, dass Gegenstände oder Personen angehoben werden). Zur Wiederherstellung des Normalbetriebs ist ein neuer Öffnungsimpuls erforderlich.

Wenn ein Hindernis drei Mal hintereinander beim Schließen an derselben Stelle erfasst wird, erkennt die Automation diese Position als neuen Schließanschlag und setzt sich in den Zustand „geschlossen“. Für die Wiederherstellung der korrekten Positionen das Hindernis entfernen und einen neuen Zyklus fahren: Beim nächsten Schließen fährt die Automation bei verlangsamerter Geschwindigkeit bis sie den Anschlag ermittelt.

In der Regel ist das Tor geschlossen. Wenn die elektronische Steuerung einen Öffnungsimpuls über die Funksteuerung oder einen beliebigen anderen Impulsgeber empfängt (Abb. 1), wird der Elektromotor in Betrieb gesetzt, der das Tor über einen Ketten- oder Riemenantrieb öffnet und Zugang/Zufahrt ermöglicht.

- Wenn der Automatikbetrieb eingestellt wurde, schließt sich das Tor selbstständig nach der Pausenzeit. Ein während der Öffnung gesendeter Öffnungsimpuls hat keinerlei Wirkung.

- Wenn der halbautomatische Betrieb eingestellt wurde, muss ein zweiter Impuls gesendet werden, damit sich das Tor wieder schließt.

- Wenn beim Öffnen ein Impuls für die Öffnung gesendet wird, wird die Bewegung angehalten. Wenn beim Schließen ein Impuls für die Öffnung gesendet wird, erfolgt stets die Umkehrung der Bewegung.

- Ein Halteimpuls (wenn vorgesehen) stoppt stets die Bewegung.

Für die detaillierte Beschreibung des Verhaltens des Tors mit den verschiedenen Steuerlogiken wenden Sie sich bitte an den mit der Installation beauftragten Techniker.

Die Automationen können Zubehörteile (Fotozellen) enthalten, die das erneute Schließen des Tors verhindern, wenn sich ein Hindernis in dem jeweiligen abgesicherten Bereich befindet.

Die Notöffnung per Hand kann mit Hilfe des entsprechenden Entriegelungssystems ermöglicht werden.

Das Leuchtsignal (wenn vorgesehen) signalisiert die laufende Torbewegung.

Die Servicelampe geht beim Anlaufen des Motors an und geht etwa 2 Minuten nach dem Stillstand des Motors aus. Wenn die Servicelampe blinkt, ist die Automation aufgrund einer Störung blockiert. Qualifizierte Fachkräfte für die Reparatur benachrichtigen.

**HANDBETRIEB**

Der Antrieb D600 ist mit einem System für die Notentriegelung von innen ausgerüstet. Auf Anfrage kann ein Schloss angebracht werden, durch das die Betätigung der Entriegelung auch von außen möglich ist.

Sollte es aufgrund von Stromausfall oder Betriebsstörungen der Automation erforderlich sein, das Tor mit der Hand zu betätigen, sind folgende Maßnahmen an der Entriegelungsvorrichtung vorzunehmen:

- Die Stromzufuhr zur Anlage unterbrechen.
- Den Antrieb entriegeln und hierzu den Freigabeknauf nach unten ziehen (Abb. 2 Bez. A).

**Achtung: Vermeiden, dass sich Personen, Tiere oder Gegenstände während der Entriegelung im Bewegungsbereich des Tors aufhalten bzw. befinden.**

**WIEDERHERSTELLUNG DES AUTOMATIKBETRIEBS**

- Die Automation erneut verriegeln und hierzu den Griff waagrecht ziehen (Abb. 2 Bez. B) und sicherstellen, dass das Fenster „LOCK“ unterhalb des Schlittens beim Loslassen rot ist. Dies bedeutet, dass der Betrieb ordnungsgemäß wiederhergestellt wurde.

- Das Tor bis zur Kupplungsstelle bewegen.
- Die Anlage wieder mit Strom versorgen.

**WARTUNG**

Bei der Automation D600 müssen keine Teile regelmäßig ausgewechselt werden.

**AUSWECHSELN DER SERVICELAMPE**

Zum Auswechseln der Servicelampe ist die Deckenbefestigung mit einem Hand zu greifen und nach unten zu ziehen, wie in der Abb. 3 angegeben.

Die Birne herausschrauben (Typ E27 - 230 Vac - max 40 W) und die Deckenbefestigung wieder montieren.

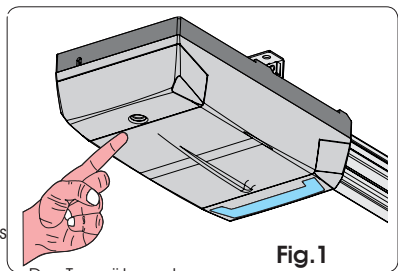

Fig.1



Abb.2



Abb.3

# WARTUNGSPROGRAMM

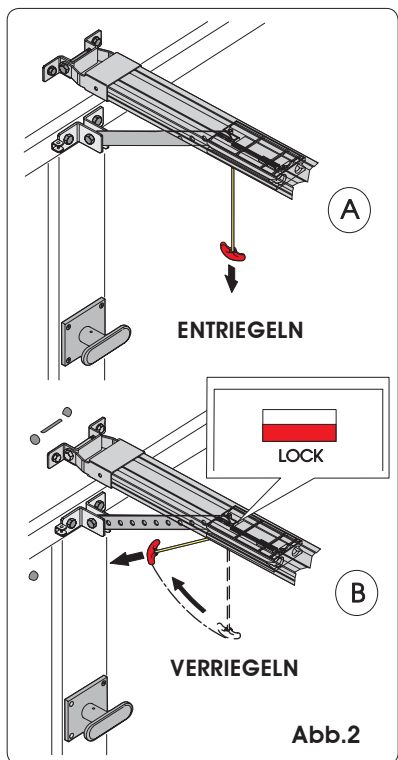
## Daten der Anlage

<i>Monteur</i>	
<i>Kunde</i>	
<i>Art der Anlage</i>	
<i>Seriennummer</i>	
<i>Installationsdatum</i>	
<i>Inbetriebnahme</i>	

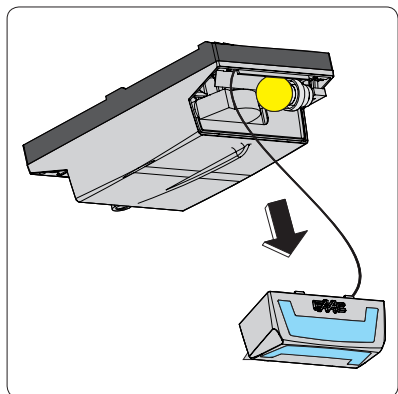
## Konfiguration der Anlage

BAUTEIL	MODELL	SERIENNUMMER
Antrieb		
Sicherheitsvorrichtung 1		
Sicherheitsvorrichtung 2		
Fotzellenpaar 1		
Fotzellenpaar 2		
Schaltvorrichtung 1		
Schaltvorrichtung 2		
Funksteuerung		
Blinkleuchte		

## Angabe der Restriktionen und der voraussehbaren unsachgemäßen Anwendung

Nr.	Datum	Beschreibung der Arbeiten	Unterschrift
1			Techniker Kunde
2			Techniker Kunde
3			Techniker Kunde
4			Techniker Kunde
5			Techniker Kunde
6			Techniker Kunde
7			Techniker Kunde
8			Techniker Kunde
9			Techniker Kunde
10			Techniker Kunde

## AUTOMACIÓN D600

### Guía para el usuario

Lea detenidamente las instrucciones antes de utilizar el producto y consérvelas para posibles usos futuros.

#### NORMAS GENERALES DE SEGURIDAD

La automatización D600, si se instala y utiliza correctamente, garantiza un elevado grado de seguridad.

Algunas simples normas de comportamiento pueden evitar inconvenientes o accidentes:

- No se detenga absolutamente debajo de la puerta.
- No permita que personas, animales u objetos estén detenidos cerca de la automatización, especialmente durante el funcionamiento.
- Sólo puede transitarse con la puerta completamente abierta y con la automatización parada. Mantenga bajo control la puerta durante todo el movimiento e impida que otras personas se acerquen al área interesada.
- Mantenga fuera del alcance de los niños los radiomandos o cualquier otro generador de impulsos para evitar que la automatización pueda accionarse involuntariamente.



#### - ¡ATENCIÓN! PELIGRO DE APLASTAMIENTO.

- Compruebe mensualmente que el sistema antiaplastamiento pueda detectar la presencia de un obstáculo de 50mm de altura situado en el suelo.
- No permita que los niños jueguen con la automatización.
- No obstaculice voluntariamente el movimiento de la puerta.
- Evite que ramas o arbustos interfieran con el movimiento de la puerta.
- Mantenga en buen estado y bien visibles los sistemas de señalización luminosa.

- No intente accionar manualmente la puerta si no está desbloqueada.

- En caso de mal funcionamiento, desbloquee la puerta para permitir el acceso y espere a que personal técnico cualificado intervenga para solucionar el problema.

- Una vez preparado el funcionamiento manual, quite la alimentación eléctrica al equipo antes de reanudar el funcionamiento normal.

- No efectúe ninguna modificación en los componentes que formen parte del sistema de automatización.

- Absténgase de intentar reparar o de intervenir directamente, diríjase exclusivamente a personal cualificado FAAC.

- Haga verificar por lo menos semestralmente el funcionamiento de la automatización y de los dispositivos de seguridad por personal cualificado.

#### DESCRIPCIÓN

La automatización D600 es ideal para automatizar puertas seccionales equilibradas de garajes individuales residenciales.

Las automatizaciones están formadas por un operador electromecánico, un equipo electrónico de control, una luz de cortesía y un cárter de protección integrados en un único monobloque.

El sistema irreversible garantiza el bloqueo mecánico de la puerta cuando el motor no está en funcionamiento, por lo que no es necesario instalar cerradura alguna; un desbloqueo manual permite maniobrar la puerta en caso de falta de alimentación eléctrica o de avería.

La automatización está provista de un sistema electrónico para la detección de obstáculos. Si se detecta un obstáculo durante la maniobra de cierre, la automatización abre de nuevo completamente la puerta. Si la automatización funciona en lógica automática, la puerta se volverá a cerrar después del tiempo de pausa, en caso contrario será necesario dar un nuevo impulso para mandar el cierre. Durante la maniobra de apertura, si se detecta un obstáculo, se detiene el movimiento (esto para evitar la elevación de personas o cosas). Para restablecer el normal funcionamiento hay que dar un nuevo impulso de apertura.

Si durante el cierre se detecta un obstáculo en la misma posición durante tres veces consecutivas, la automatización toma dicha cota como nuevo tope de cierre y se pone en estado de cerrado. Para restablecer las correctas posiciones, elimine el obstáculo y mande un nuevo ciclo: al siguiente cierre la automatización avanzará a velocidad reducida hasta localizar el tope.

La puerta normalmente está cerrada; cuando la centralita electrónica recibe un mando de apertura mediante un radiomando, o cualquier otro generador de impulsos (Fig. 1), acciona el motor eléctrico el cual, mediante transmisión de cadena o de correa, arrastra el portón hasta la posición de apertura y permite el acceso.

- Si se ha programado el funcionamiento automático, la puerta se cierra sola transcurrido el tiempo de pausa. Un impulso de apertura durante la fase de apertura no tiene ningún efecto.

- Si se ha programado el funcionamiento semiautomático, es necesario enviar un segundo impulso para obtener el cierre.

- Un impulso de apertura durante la fase de apertura detiene el movimiento. Un impulso de apertura durante la fase de cierre causa siempre la inversión del movimiento.

- Un impulso de stop (si estuviera previsto) detiene siempre el movimiento.

Para conocer en detalle el comportamiento de la puerta en las diferentes lógicas de funcionamiento, consulte al Técnico instalador.

En las automatizaciones pueden estar presentes accesorios (fotocélulas) que impiden que la puerta se cierre cuando hay un obstáculo en la zona por las mismas controladas.

La apertura manual de emergencia sólo es posible si se interviene en el correspondiente sistema de desbloqueo.

La señalización luminosa (si estuviera prevista) indica el movimiento en acto de la puerta.

La luz de cortesía se activa cuando arranca el motor y permanece encendida durante unos 2 minutos después de que se apaga el motor. Si la luz de cortesía destella significa que la automatización está bloqueada debido a una anomalía, por lo que hay que solicitar la intervención de personal cualificado para la reparación.

La luz de cortesía se activa cuando arranca el motor y permanece encendida durante unos 2 minutos después de que se apaga el motor. Si la luz de cortesía destella significa que la automatización está bloqueada debido a una anomalía, por lo que hay que solicitar la intervención de personal cualificado para la reparación.

La luz de cortesía se activa cuando arranca el motor y permanece encendida durante unos 2 minutos después de que se apaga el motor. Si la luz de cortesía destella significa que la automatización está bloqueada debido a una anomalía, por lo que hay que solicitar la intervención de personal cualificado para la reparación.

La luz de cortesía se activa cuando arranca el motor y permanece encendida durante unos 2 minutos después de que se apaga el motor. Si la luz de cortesía destella significa que la automatización está bloqueada debido a una anomalía, por lo que hay que solicitar la intervención de personal cualificado para la reparación.

La luz de cortesía se activa cuando arranca el motor y permanece encendida durante unos 2 minutos después de que se apaga el motor. Si la luz de cortesía destella significa que la automatización está bloqueada debido a una anomalía, por lo que hay que solicitar la intervención de personal cualificado para la reparación.

La luz de cortesía se activa cuando arranca el motor y permanece encendida durante unos 2 minutos después de que se apaga el motor. Si la luz de cortesía destella significa que la automatización está bloqueada debido a una anomalía, por lo que hay que solicitar la intervención de personal cualificado para la reparación.

La luz de cortesía se activa cuando arranca el motor y permanece encendida durante unos 2 minutos después de que se apaga el motor. Si la luz de cortesía destella significa que la automatización está bloqueada debido a una anomalía, por lo que hay que solicitar la intervención de personal cualificado para la reparación.

La luz de cortesía se activa cuando arranca el motor y permanece encendida durante unos 2 minutos después de que se apaga el motor. Si la luz de cortesía destella significa que la automatización está bloqueada debido a una anomalía, por lo que hay que solicitar la intervención de personal cualificado para la reparación.

La luz de cortesía se activa cuando arranca el motor y permanece encendida durante unos 2 minutos después de que se apaga el motor. Si la luz de cortesía destella significa que la automatización está bloqueada debido a una anomalía, por lo que hay que solicitar la intervención de personal cualificado para la reparación.

La luz de cortesía se activa cuando arranca el motor y permanece encendida durante unos 2 minutos después de que se apaga el motor. Si la luz de cortesía destella significa que la automatización está bloqueada debido a una anomalía, por lo que hay que solicitar la intervención de personal cualificado para la reparación.

La luz de cortesía se activa cuando arranca el motor y permanece encendida durante unos 2 minutos después de que se apaga el motor. Si la luz de cortesía destella significa que la automatización está bloqueada debido a una anomalía, por lo que hay que solicitar la intervención de personal cualificado para la reparación.

La luz de cortesía se activa cuando arranca el motor y permanece encendida durante unos 2 minutos después de que se apaga el motor. Si la luz de cortesía destella significa que la automatización está bloqueada debido a una anomalía, por lo que hay que solicitar la intervención de personal cualificado para la reparación.

La luz de cortesía se activa cuando arranca el motor y permanece encendida durante unos 2 minutos después de que se apaga el motor. Si la luz de cortesía destella significa que la automatización está bloqueada debido a una anomalía, por lo que hay que solicitar la intervención de personal cualificado para la reparación.

La luz de cortesía se activa cuando arranca el motor y permanece encendida durante unos 2 minutos después de que se apaga el motor. Si la luz de cortesía destella significa que la automatización está bloqueada debido a una anomalía, por lo que hay que solicitar la intervención de personal cualificado para la reparación.

La luz de cortesía se activa cuando arranca el motor y permanece encendida durante unos 2 minutos después de que se apaga el motor. Si la luz de cortesía destella significa que la automatización está bloqueada debido a una anomalía, por lo que hay que solicitar la intervención de personal cualificado para la reparación.

La luz de cortesía se activa cuando arranca el motor y permanece encendida durante unos 2 minutos después de que se apaga el motor. Si la luz de cortesía destella significa que la automatización está bloqueada debido a una anomalía, por lo que hay que solicitar la intervención de personal cualificado para la reparación.

La luz de cortesía se activa cuando arranca el motor y permanece encendida durante unos 2 minutos después de que se apaga el motor. Si la luz de cortesía destella significa que la automatización está bloqueada debido a una anomalía, por lo que hay que solicitar la intervención de personal cualificado para la reparación.

La luz de cortesía se activa cuando arranca el motor y permanece encendida durante unos 2 minutos después de que se apaga el motor. Si la luz de cortesía destella significa que la automatización está bloqueada debido a una anomalía, por lo que hay que solicitar la intervención de personal cualificado para la reparación.

La luz de cortesía se activa cuando arranca el motor y permanece encendida durante unos 2 minutos después de que se apaga el motor. Si la luz de cortesía destella significa que la automatización está bloqueada debido a una anomalía, por lo que hay que solicitar la intervención de personal cualificado para la reparación.

La luz de cortesía se activa cuando arranca el motor y permanece encendida durante unos 2 minutos después de que se apaga el motor. Si la luz de cortesía destella significa que la automatización está bloqueada debido a una anomalía, por lo que hay que solicitar la intervención de personal cualificado para la reparación.

La luz de cortesía se activa cuando arranca el motor y permanece encendida durante unos 2 minutos después de que se apaga el motor. Si la luz de cortesía destella significa que la automatización está bloqueada debido a una anomalía, por lo que hay que solicitar la intervención de personal cualificado para la reparación.

La luz de cortesía se activa cuando arranca el motor y permanece encendida durante unos 2 minutos después de que se apaga el motor. Si la luz de cortesía destella significa que la automatización está bloqueada debido a una anomalía, por lo que hay que solicitar la intervención de personal cualificado para la reparación.

La luz de cortesía se activa cuando arranca el motor y permanece encendida durante unos 2 minutos después de que se apaga el motor. Si la luz de cortesía destella significa que la automatización está bloqueada debido a una anomalía, por lo que hay que solicitar la intervención de personal cualificado para la reparación.

La luz de cortesía se activa cuando arranca el motor y permanece encendida durante unos 2 minutos después de que se apaga el motor. Si la luz de cortesía destella significa que la automatización está bloqueada debido a una anomalía, por lo que hay que solicitar la intervención de personal cualificado para la reparación.

La luz de cortesía se activa cuando arranca el motor y permanece encendida durante unos 2 minutos después de que se apaga el motor. Si la luz de cortesía destella significa que la automatización está bloqueada debido a una anomalía, por lo que hay que solicitar la intervención de personal cualificado para la reparación.

La luz de cortesía se activa cuando arranca el motor y permanece encendida durante unos 2 minutos después de que se apaga el motor. Si la luz de cortesía destella significa que la automatización está bloqueada debido a una anomalía, por lo que hay que solicitar la intervención de personal cualificado para la reparación.

La luz de cortesía se activa cuando arranca el motor y permanece encendida durante unos 2 minutos después de que se apaga el motor. Si la luz de cortesía destella significa que la automatización está bloqueada debido a una anomalía, por lo que hay que solicitar la intervención de personal cualificado para la reparación.

La luz de cortesía se activa cuando arranca el motor y permanece encendida durante unos 2 minutos después de que se apaga el motor. Si la luz de cortesía destella significa que la automatización está bloqueada debido a una anomalía, por lo que hay que solicitar la intervención de personal cualificado para la reparación.

La luz de cortesía se activa cuando arranca el motor y permanece encendida durante unos 2 minutos después de que se apaga el motor. Si la luz de cortesía destella significa que la automatización está bloqueada debido a una anomalía, por lo que hay que solicitar la intervención de personal cualificado para la reparación.

La luz de cortesía se activa cuando arranca el motor y permanece encendida durante unos 2 minutos después de que se apaga el motor. Si la luz de cortesía destella significa que la automatización está bloqueada debido a una anomalía, por lo que hay que solicitar la intervención de personal cualificado para la reparación.

La luz de cortesía se activa cuando arranca el motor y permanece encendida durante unos 2 minutos después de que se apaga el motor. Si la luz de cortesía destella significa que la automatización está bloqueada debido a una anomalía, por lo que hay que solicitar la intervención de personal cualificado para la reparación.

La luz de cortesía se activa cuando arranca el motor y permanece encendida durante unos 2 minutos después de que se apaga el motor. Si la luz de cortesía destella significa que la automatización está bloqueada debido a una anomalía, por lo que hay que solicitar la intervención de personal cualificado para la reparación.

La luz de cortesía se activa cuando arranca el motor y permanece encendida durante unos 2 minutos después de que se apaga el motor. Si la luz de cortesía destella significa que la automatización está bloqueada debido a una anomalía, por lo que hay que solicitar la intervención de personal cualificado para la reparación.

La luz de cortesía se activa cuando arranca el motor y permanece encendida durante unos 2 minutos después de que se apaga el motor. Si la luz de cortesía destella significa que la automatización está bloqueada debido a una anomalía, por lo que hay que solicitar la intervención de personal cualificado para la reparación.

La luz de cortesía se activa cuando arranca el motor y permanece encendida durante unos 2 minutos después de que se apaga el motor. Si la luz de cortesía destella significa que la automatización está bloqueada debido a una anomalía, por lo que hay que solicitar la intervención de personal cualificado para la reparación.

La luz de cortesía se activa cuando arranca el motor y permanece encendida durante unos 2 minutos después de que se apaga el motor. Si la luz de cortesía destella significa que la automatización está bloqueada debido a una anomalía, por lo que hay que solicitar la intervención de personal cualificado para la reparación.

La luz de cortesía se activa cuando arranca el motor y permanece encendida durante unos 2 minutos después de que se apaga el motor. Si la luz de cortesía destella significa que la automatización está bloqueada debido a una anomalía, por lo que hay que solicitar la intervención de personal cualificado para la reparación.

La luz de cortesía se activa cuando arranca el motor y permanece encendida durante unos 2 minutos después de que se apaga el motor. Si la luz de cortesía destella significa que la automatización está bloqueada debido a una anomalía, por lo que hay que solicitar la intervención de personal cualificado para la reparación.

La luz de cortesía se activa cuando arranca el motor y permanece encendida durante unos 2 minutos después de que se apaga el motor. Si la luz de cortesía destella significa que la automatización está bloqueada debido a una anomalía, por lo que hay que solicitar la intervención de personal cualificado para la reparación.

La luz de cortesía se activa cuando arranca el motor y permanece encendida durante unos 2 minutos después de que se apaga el motor. Si la luz de cortesía destella significa que la automatización está bloqueada debido a una anomalía, por lo que hay que solicitar la intervención de personal cualificado para la reparación.

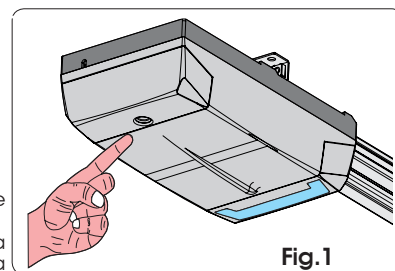

Fig.1

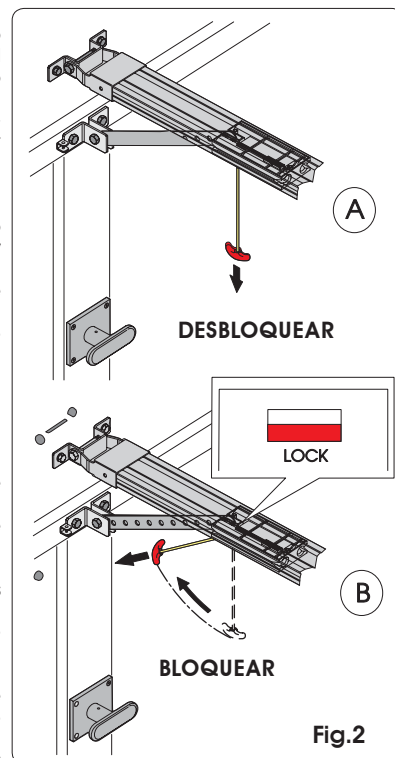

Fig.2

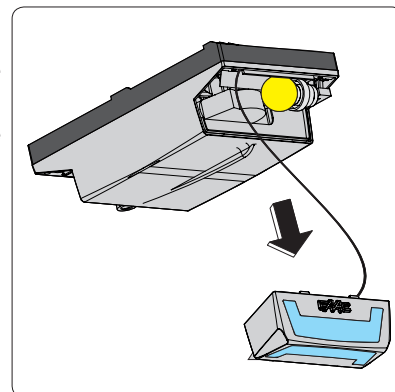

Fig.3

Desenrosque la bombilla (tipo E27 - 230 Vac - máx. 40 W) y colóquela de nuevo en el plátón.

Para sustituir la luz aferre con una mano el plátón y tire del mismo hacia abajo, como se indica en la Fig. 3.

# REGISTRO DE MANTENIMIENTO

## Datos equipo

Instalador	
Cliente	
Tipo de equipo	
Nº de serie	
Fecha de instalación	
Activación	

## Configuración del equipo

COMPONENTE	MODELO	Nº DE SERIE
Operador		
Dispositivo de seguridad 1		
Dispositivo de seguridad 2		
Par de fotocélulas 1		
Par de fotocélulas 2		
Dispositivo de mando 1		
Dispositivo de mando 2		
Radiomando		
Destellador		

## Indicación de los riesgos residuos y del uso impropio previsible

Nº	Fecha	Descripción de la intervención	Firma
1			Técnico
			Cliente
2			Técnico
			Cliente
3			Técnico
			Cliente
4			Técnico
			Cliente
5			Técnico
			Cliente
6			Técnico
			Cliente
7			Técnico
			Cliente
8			Técnico
			Cliente
9			Técnico
			Cliente
10			Técnico
			Cliente

**AUTOMATISCH SYSTEEM D600**

**Gebruikersgids**

Lees de instructies aandachtig door alvorens het product te gebruiken, en bewaar ze voor eventuele toekomstige raadpleging.

**ALGEMENE VEILIGHEIDSVOORSCHRIFTEN**

Het automatische systeem D600 garandeert, als het op correcte wijze is geïnstalleerd en gebruikt, een hoge mate van veiligheid.

Daarnaast kunnen een aantal simpele gedragsregels accidentele ongemakken voorkomen:

- Blijf nooit onder de deur staan.
- Zorg dat er geen personen, dieren of voorwerpen in de buurt van het automatische systeem staan, vooral terwijl hij in werking is.
- Er mag pas onder de deur door worden gegaan als het automatische systeem stil staat. Houd gedurende heel de beweging de deur in de gaten en zorg dat er geen andere personen in de betreffende zone komen.
- Houd de afstandsbediening en alle andere impulsgevers waarmee de deur kan worden bediend buiten het bereik van kinderen.

**- LET OP! BEKNELLINGSGEVAAR.**

- Controleer maandelijks of de beknellingsbeveiliging in staat is een obstakel op de grond met een hoogte van 50 mm te detecteren.
- Laat kinderen nooit met het automatische systeem spelen.
- Houd niet opzettelijk de beweging van de deur tegen.
- Zorg dat takken of struiken de beweging van de deur niet kunnen hinderen.
- Zorg dat de lichtsignalen altijd goed werken en goed zichtbaar zijn.



- Probeer de deur niet met de hand te bewegen als hij niet eerst ontgrendeld is.

- In geval van storing moet de deur worden ontgrendeld om toegang mogelijk te maken, en wacht op de technische assistentie van deskundig personeel.
- Als de handbediende werking is ingesteld, moet de elektrische voeding naar de installatie worden uitgeschakeld alvorens de normale werking te hervatten.
- Voer geen wijzigingen uit op onderdelen die deel uitmaken van het automatische systeem.
- Doe geen pogingen tot reparaties of directe ingrepen, en wend u uitsluitend tot deskundig personeel van FAAC.
- Laat de werking van het automatische systeem en de veiligheidsvoorzieningen minstens eenmaal per half jaar controleren door deskundig personeel.

**BESCHRIJVING**

Het automatische systeem D600 is ideaal om gebalanceerde sectionale garagedeuren bij woningen te automatiseren.

De automatische systemen bestaan uit een elektromechanische aandrijving, elektronische bedieningsapparatuur, verlichting en een behuizing, ondergebracht in een monoblok.

Het onomkeerbare systeem garandeert een mechanische vergrendeling van de deur wanneer de motor niet in werking is, zodat er geen slot hoeft te worden geïnstalleerd; een handmatige ontgrendeling zorgt ervoor dat de deur kan worden bewogen in geval van een black-out of een storing.

Het automatische systeem is voorzien van een elektronisch systeem om obstakels te detecteren. Als tijdens de sluitingsmanoeuvre een obstakel wordt gedetecteerd, opent het automatische systeem de deur weer helemaal. Als het automatische systeem met een automatische logica werkt zal de deur na een pauzetijd weer sluiten, als dat niet het geval is, moet opnieuw een impuls worden gegeven om de deur te sluiten. Al tijdens de openingsmanoeuvre een obstakel wordt gedetecteerd, wordt de beweging stopgezet (om te voorkomen dat personen of voorwerpen worden opgetild). Om de normale werking te herstellen moet opnieuw een openingsimpuls worden gegeven.

Als tijdens het sluiten drie keer achter elkaar een obstakel op dezelfde plaats wordt gedetecteerd, beschouwt het automatische systeem deze waarde als de nieuwe aanslag voor het sluiten, en gaat hij over op de gesloten stand. Om de correcte posities te herstellen moet het obstakel worden verwijderd en het commando voor een nieuwe cyclus worden gegeven: als de deur vervolgens wordt gesloten, zal het automatische systeem vertraagd bewegen tot de aanslag wordt gedetecteerd.

De deur is normaal gesproken gesloten; wanneer de elektronische besturingseenheid een openingscommando ontvangt van een afstandsbediening of een willekeurige andere impulsgever (Fig. 1), schakelt hij de elektrische motor in, die door middel van een ketting- of riemtransmissie de deur open trekt en toegang mogelijk maakt.

- Als de automatische werking is ingesteld, sluit de deur vervolgens uit zichzelf na de pauzetijd. Als tijdens de openingsfase een openingsimpuls wordt gegeven, heeft dit geen enkel effect.
- Als de halfautomatische werking is ingesteld, moet een tweede impuls worden gegeven om de poort weer te sluiten.
- Als tijdens het openen een impuls voor opening wordt gegeven, wordt de beweging stopgezet. Als tijdens het sluiten een impuls voor opening wordt gegeven, wordt altijd de beweging omgekeerd.

- Een stop-impuls (indien voorzien) zorgt er altijd voor dat de beweging wordt gestopt. Raadpleeg een installatietechnicus voor het gedetailleerde gedrag van de deur met de verschillende logica's. Automatische systemen kunnen veiligheidsvoorzieningen (fotocellen) hebben die verhinderen dat de deur weer sluit als er zich een obstakel in het door hen beveiligde gebied bevindt.

De handbediende opening in noodgevallen is alleen mogelijk met behulp van het speciale ontgrendelingsmechanisme. Het lichtsignaal (indien voorzien) geeft aan dat de deur in beweging is.

De verlichting gaat aan wanneer de motor start, en blijft branden tot ongeveer 2 minuten nadat de motor is uitgegaan. Als de verlichting knippert, is het automatische systeem geblokkeerd vanwege een storing en moet er deskundig personeel bij worden gehaald om de storing te verhelpen.

**HANDBEDIENDE WERKING**

De aandrijving D600 is uitgerust met een ontgrendelingsmechanisme voor noodgevallen dat van binnenuit kan worden bediend; er kan, op verzoek, een slot worden aangebracht waarmee de deur tevens van buitenaf kan worden ontgrendeld.

Als de deur moet worden bediend omdat de elektrische voeding is uitgevallen of omdat het automatische systeem niet goed werkt, dient het ontgrendelingsmechanisme te worden gebruikt, en wel als volgt.

- Schakel de stroomtoevoer naar de installatie uit.
- Ontgrendel de aandrijving door de ontgrendelingshendel naar beneden te trekken (Fig. 2 ref. A).

**Let op: zorg dat er zich tijdens de ontgrendelingsmanoeuvre geen mensen, dieren of voorwerpen in de bewegingszone van de deur bevinden.**

**HERVATTING AUTOMATISCHE WERKING**

- Vergrendel het automatische systeem weer door het handvat horizontaal te trekken (Fig. 2 ref. B) en controleer, wanneer hij wordt losgelaten, of het "LOCK"-venstertje onder de geleideslede rood is, ter bevestiging dat het mechanisme weer is ingesteld.
- Beweeg de deur tot aan het aangrijppunt.
- Schakel de stroomtoevoer naar de installatie weer in.

**ONDERHOUD**

Het automatische systeem D600 vereist geen periodieke vervanging van onderdelen.

**VERVANGING LAMPJE VERLICHTING**

Om de lamp te vervangen moet de plafonnière met één hand worden vastgepakt en naar bened worden getrokken, zoals aangegeven in Fig. 3.

Draai de lamp (type E27 - 230 Vac - max. 40 W) los en zet de plafonnière weer op zijn plaats.

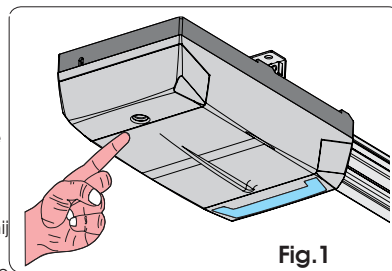

Fig.1

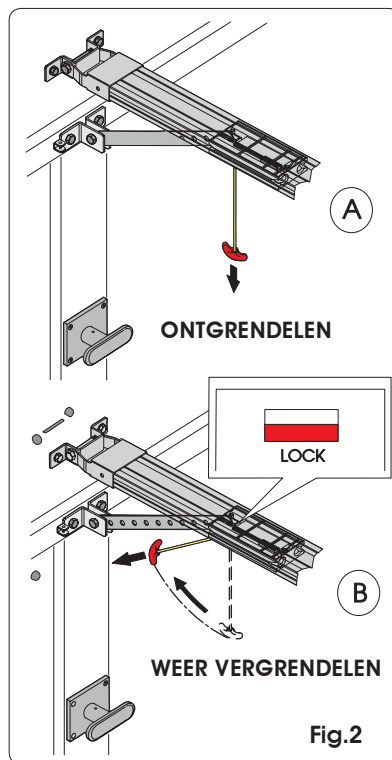

Fig.2

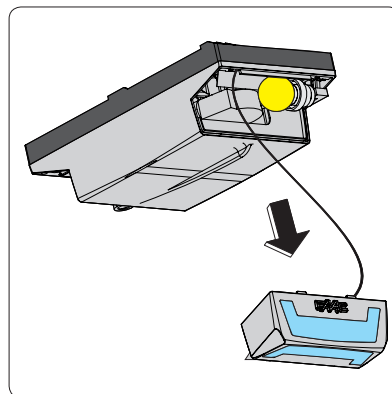

Fig.3



# ONDERHOUDREGISTER

## Gegevens installatie

<i>Installateur</i>	
<i>Klant</i>	
<i>Type installatie</i>	
<i>Serienummer</i>	
<i>Datum installatie</i>	
<i>Activering</i>	

## Configuratie installatie

ONDERDEEL	MODEL	SERIENUMMER
Aandrijving		
Veiligheidsvoorziening 1		
Veiligheidsvoorziening 2		
Paar fotocellen 1		
Paar fotocellen 2		
Bedieningsvoorziening 1		
Bedieningsvoorziening 2		
Afstandsbediening		
Signaallamp		

## Aanduiding van de restrictie's en van voorzienbaar oneigenlijk gebruik

Nr.	Datum	Beschrijving ingreep	Handtekeningen
1			Technicus Klant
2			Technicus Klant
3			Technicus Klant
4			Technicus Klant
5			Technicus Klant
6			Technicus Klant
7			Technicus Klant
8			Technicus Klant
9			Technicus Klant
10			Technicus Klant



Le descrizioni e le illustrazioni del presente manuale non sono impegnative. La FAAC si riserva il diritto, lasciando inalterate le caratteristiche essenziali dell'apparecchiatura, di apportare in qualunque momento e senza impegnarsi ad aggiornare la presente pubblicazione, le modifiche che essa ritiene convenienti per miglioramenti tecnici o per qualsiasi altra esigenza di carattere costruttivo o commerciale.

The descriptions and illustrations contained in the present manual are not binding. FAAC reserves the right, whilst leaving the main features of the equipments unaltered, to undertake any modifications it holds necessary for either technical or commercial reasons, at any time and without revising the present publication.

Les descriptions et les illustrations du présent manuel sont fournies à titre indicatif. FAAC se réserve le droit d'apporter à tout moment les modifications qu'elle jugera utiles sur ce produit tout en conservant les caractéristiques essentielles, sans devoir pour autant mettre à jour cette publication.

Die Beschreibungen und Abbildungen in vorliegendem Handbuch sind unverbindlich. FAAC behält sich das Recht vor, ohne die wesentlichen Eigenschaften dieses Gerätes zu verändern und ohne Verbindlichkeiten in Bezug auf die Neufassung der vorliegenden Anleitungen, technisch bzw. konstruktiv/kommerziell bedingte Verbesserungen vorzunehmen.

Las descripciones y las ilustraciones de este manual no comportan compromiso alguno. FAAC se reserva el derecho, dejando inmutadas las características esenciales de los aparatos, de aportar, en cualquier momento y sin comprometerse a poner al día la presente publicación, todas las modificaciones que considere oportunas para el perfeccionamiento técnico o para cualquier otro tipo de exigencia de carácter constructivo o comercial.

De beschrijvingen in deze handleiding zijn niet bindend. FAAC behoudt zich het recht voor op elk willekeurig moment de veranderingen aan te brengen die het bedrijf nuttig acht met het oog op technische verbeteringen of alle mogelijke andere productie- of commerciële eisen, waarbij de fundamentele eigenschappen van de apparaat gehandhaafd blijven, zonder zich daardoor te verplichten deze publicatie bij te werken.



# FAAC

**FAAC S.p.A.**  
Via Benini, 1  
40069 Zola Predosa (BO) - ITALIA  
Tel. 0039.051.61724 - Fax. 0039.051.758518  
[www.faac.it](http://www.faac.it)  
[www.faacgroup.com](http://www.faacgroup.com)

