

5. START-UP

5.1. CONNECTION TO ELECTRONIC CONTROL UNIT

Always disconnect the electrical power supply before carrying out any operations on the control unit (connections, programming, maintenance).

Warning: On disconnecting connector J6, high voltages may be present on the capacitor output.

Observe points 10, 11, 12, 13 and 14 in the GENERAL SAFETY INSTRUCTIONS.

As shown in Fig. 3, lay the conduits and make the electrical connections from the 844 MPS electronic control unit to the chosen accessories.

Always route the power supply cables separately from the control and safety cables (keyswitch, receiver, photocells, etc.). Use separate conduits to avoid any interference.

5.1.1. 844MPS ELECTRONIC CONTROL UNIT

TABLE 2 TECHNICAL CHARACTERISTICS OF 844MPS

Power supply	230V~ (+6 -10 %) 50Hz
Motor max. load	650 W
Accessories power supply	24Vdc/24V~
Accessories max. load	500 mA
Warning light power supply	24V~ (5W max)
Temperature range	- 20°C + 55°C
Fuses	transformer primary motor accessories
Quick connectors	- for decoding cards or RP receivers- - capacitor - limit switch -
Inputs	OPEN/STOP/CLOSING SAFETY/LIMIT-SWITCH
Outputs	warning light flashing light motor 24Vdc/24V~ -power supply for accessories pause time (5-10-15-30-60-120-180 sec.)
Logic programming	(automatic A1/S1/S2 - semiautomatic E1) pre-flashing
Motor braking	Adjustable by trimmer
Safety timing	255 sec.

5.1.2. 844MPS LAY-OUT

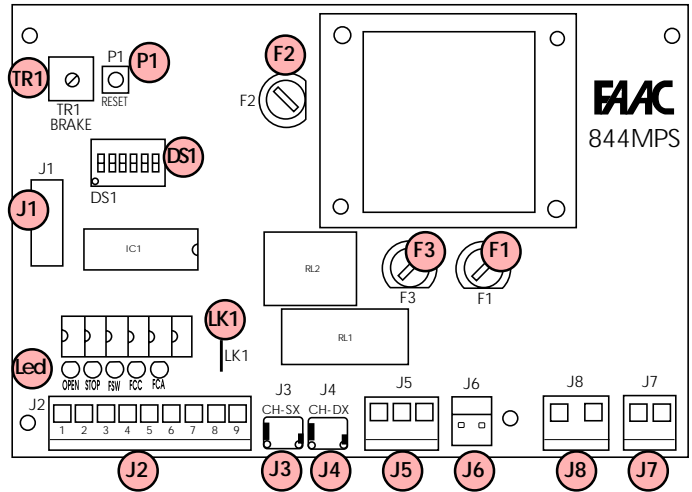

Fig. 23

TABLE 3 844MPS Control unit components

F1	Fast-acting fuse F1 5x20 F5A/250V (motor)
F2	Time delay fuse F2 5x20 T1,6A/250V (accessories)
F3	Time delay fuse F3 5x20 T250mA/250V (transformer)
P1	RESET button
TR1	Braking adjustment trimmer
DS1	Programming dipswitches
Led	Input status indicator LEDs
LK1	Jumper for warning lamp contact
J1	Quick connector for decoding cards/RP receiver
J2	Low voltage inputs/accessories terminal block
J3	Quick connector for limit switch (LH closure)
J4	Quick connector for limit switch (RH closure)
J5	Motor output terminal block
J6	Quick connector for capacitor
J7	Flasher unit output terminal block (230V~ max 60W)
J8	Line input terminal block

5.1.3. ELECTRICAL CONNECTIONS

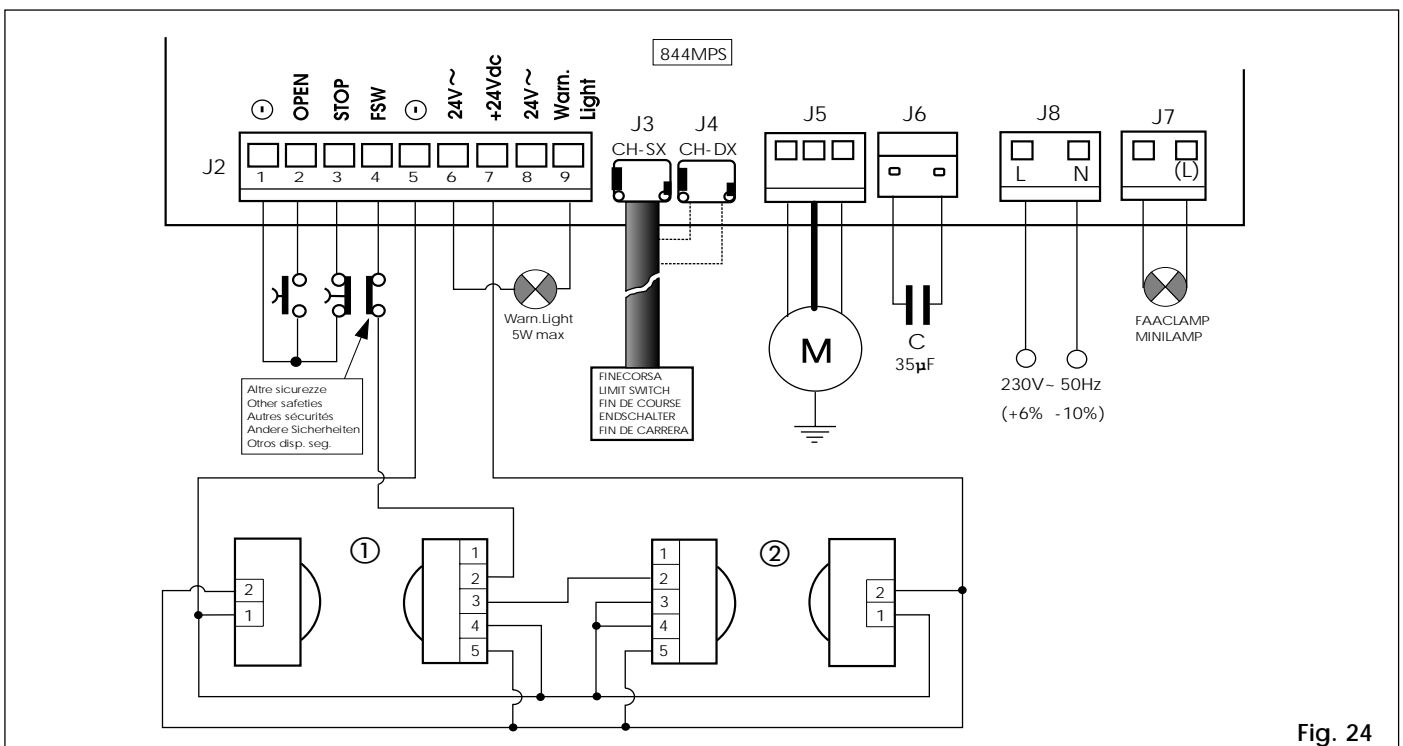
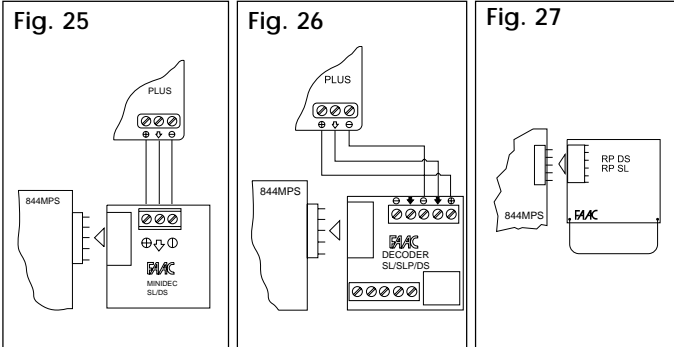

Fig. 24

5.2. DESCRIPTION

5.2.1. CONNECTOR J1

The connector J1 is used for the quick connection of MINIDEC, DECODER, RP RECEIVER boards (Figs. 25,26,27). Accessory boards are to be inserted with their component sides facing the inside of the 844MPS electronic control unit. Always disconnect the power supply before inserting or removing accessory boards.



5.2.2. TERMINAL BLOCK J2 (low voltage)

1&5 = Common/Negative of accessory power supply (-)

2 = OPEN control device (N.O.)

Any control device (pushbutton, detector,...) which, on closing the contact, relays an open and/or close impulse to the gate. To install more than one Open control device, connect the N.O. contacts in parallel.

3 = STOP control device (N.C.)

Any control device (e.g. pushbutton) which, on opening a contact, stops the movement of the gate. To install more than one Stop control device, connect the N.C. contacts in series.

⚡ If no Stop control devices are to be connected, place a jumper across the input and the common terminal (terminal 1 or 5).

4 = FSW closure safety device (N.C.)

Any control device (photocells, safety edges, magnetic loops) with an N.C. contact which interrupts the movement of the gate when an obstacle is detected within the protected area. The task of the closure safety device is to safeguard the area occupied by the gate during the closing movement.

The intervention of safety devices during gate closure causes the direction of gate movement to be reversed. These devices do not intervene during gate opening movements. If a closure safety device is tripped when the gate is open or during a pause time, they will prevent gate closure.

To install more than one safety device, connect the N.C. contacts in series.

⚡ If no closure safety devices are to be installed, place a jumper across this input and the common terminal (terminal 1 or 5).

6&8 = 24V~ accessories power supply

The maximum load of the accessories is 500mA. To calculate power draw, refer to the instructions for the individual accessories.

⚡ If the jumper LK1 is broken, the 24V~ accessories power supply is no longer available (Fig.28).

7 = 24Vdc accessories power supply positive (+)

The maximum load of the accessories is 500mA. To calculate power draw, refer to the instructions for the individual accessories.

9 = Warning Light output

For information regarding operation of the warning light, refer to the section on dipswitch programming.

Jumper LK1 allows you to free the warning light contact (Fig.28).

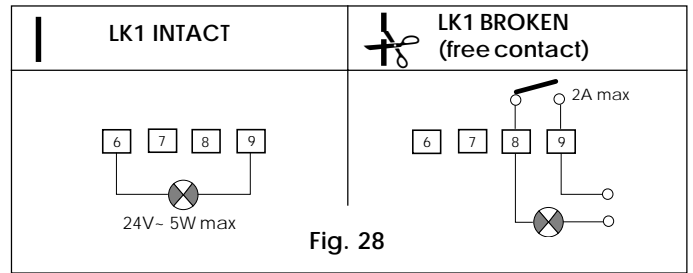

5.2.3. CONNECTORS J3-J4 (limit switch)

J3 = Connection of limit switch for left-hand closure

J4 = Connection of limit switch for right-hand closure

Refer to Figs. 29-30 for quick connection of the inductive limit switch sensor for the corresponding gate closure direction.

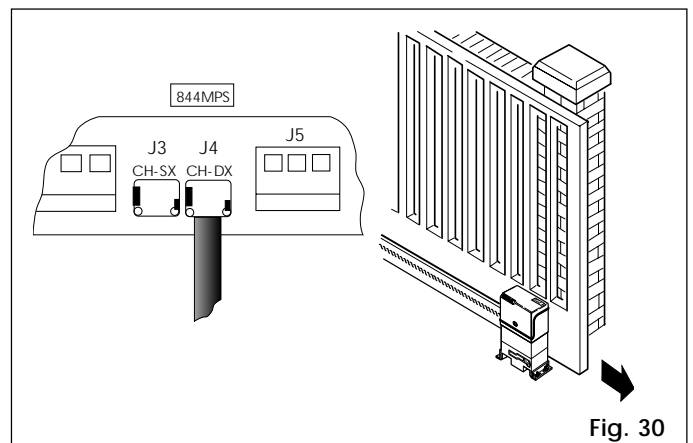
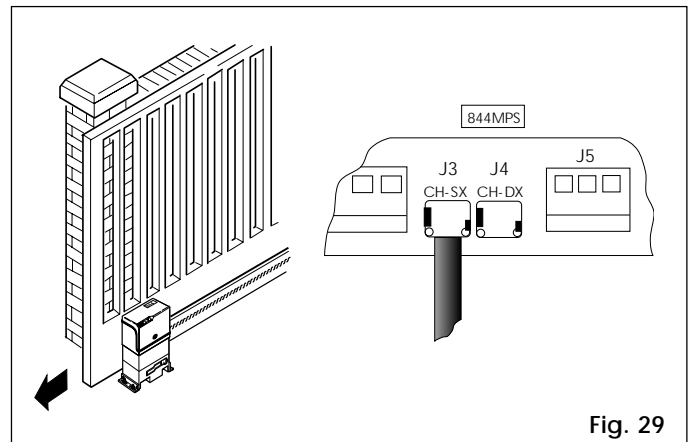

5.2.4. TERMINAL BLOCK J5 (high voltage)

Terminal block for motor connection.

⚡ Connect the wires to the terminals of J5 as shown in Fig.31.

BLACK AND BROWN WIRES = electric motor supply phases

BLUE WIRE = electric motor common

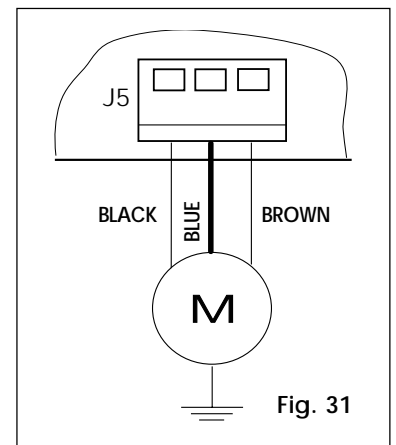

5.2.5. CONNECTOR J6 (high voltage)

Connector for quick connection of the capacitor.

5.2.6. TERMINAL BLOCK J7 (high voltage)

230V - terminal block for connection of the flashing light (max 60W).

5.2.7. TERMINAL BLOCK J8 (high voltage)

Terminal block for connection of the 230V ~ 50Hz power supply (L=Line N=Neutral)
Connect the earth wire to the operator as shown in Fig.32.

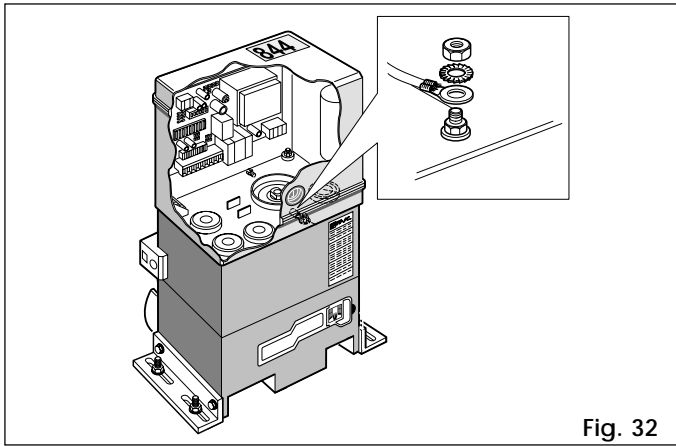

Fig. 32

5.2.8. INDICATOR LEDs

5 LEDs on the board indicate the status of the terminal inputs:

LED ON = contact closed

LED OFF = contact open

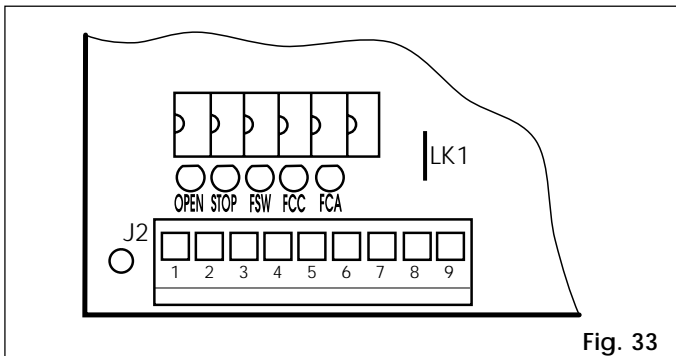
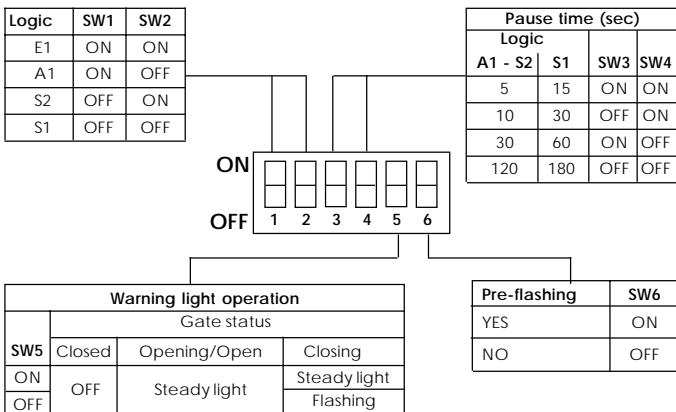

Fig. 33

TABLE 4 MEANING OF STATUS INDICATOR LEDs

LED	ON	OFF
OPEN	Command active	Command not active
STOP	Command not active	Command active
FSW	Safeties disengaged	Safeties engaged
FCC	Closing limit disengaged	Closing limit engaged
FCA	Opening limit disengaged	Opening limit engaged

5.3. DIPSWITCH SETTINGS



To program the operation of the automation, set the dipswitches as shown in the diagram above.

➡ Press the RESET button after all programming operations.

Operating logics

There are four operating logics available:

A1 = Automatic

S1 = Safety

S2 = Safety Plus

E = Semi-automatic

Operation of the different logics is described in tables 5-6-7-8.

Pause time

The pause time is amount of time the gate remains open before it re-closes when an automatic control logic is selected.

Pause times include the pre-flashing time, if selected.

Warning light operation

Allows you to vary the flashing rate of the warning light during gate closure.

Pre-flashing

It is possible to select 5 seconds pre-flashing of the flashing light before any gate movement. This serves to warn any persons in the vicinity that the gate is about to start moving.

TABLE 5 LOGIC A1 (AUTOMATIC)

GATE STATUS	IMPULSES		
	OPEN	STOP	SAFETY
CLOSED	opens and recloses after pause time (1)	no effect	no effect
OPEN	recloses after 5 s (2)	stops counting	freezes pause until disengagement
CLOSING	inverts motion	stops	inverts motion
OPENING	no effect	stops	no effect
STOPPED	recloses (1)	no effect	no effect

TABLE 6 LOGIC S1 (SAFETY)

GATE STATUS	IMPULSES		
	OPEN	STOP	SAFETY
CLOSED	opens and recloses after pause time (1)	no effect	no effect
OPEN	recloses immediately (1 and 2)	stops counting	recloses after 5 s from disengagement
CLOSING	inverts motion	stops	inverts motion
OPENING	inverts motion	stops	no effect
STOPPED	recloses (1)	no effect	no effect

TABLE 7 LOGIC S2 (SAFETY PLUS)

GATE STATUS	IMPULSES		
	OPEN	STOP	SAFETY
CLOSED	opens and recloses after pause time (1)	no effect	no effect
OPEN	recloses immediately (1 and 2)	stops counting	freezes pause until disengagement
CLOSING	inverts motion	stops	stops and inverts motion when disengaged (1)
OPENING	inverts motion	stops	no effect
STOPPED	recloses (1)	no effect	no effect

TABLE 8 LOGIC E1 (SEMI-AUTOMATIC)

GATE STATUS	IMPULSES		
	OPEN	STOP	SAFETY
CLOSED	opens (1)	no effect	no effect
OPEN	recloses (1)	no effect	no effect
CLOSING	inverts motion	stops	inverts motion
OPENING	stops	stops	no effect
STOPPED	recloses (reopens when safety devices are engaged) (1)	no effect	no effect

(1) With the pre-flashing selected, movement starts after 5 seconds.
(2) If the impulse is sent during pre-flashing, the timer is reset to zero.