

460-P

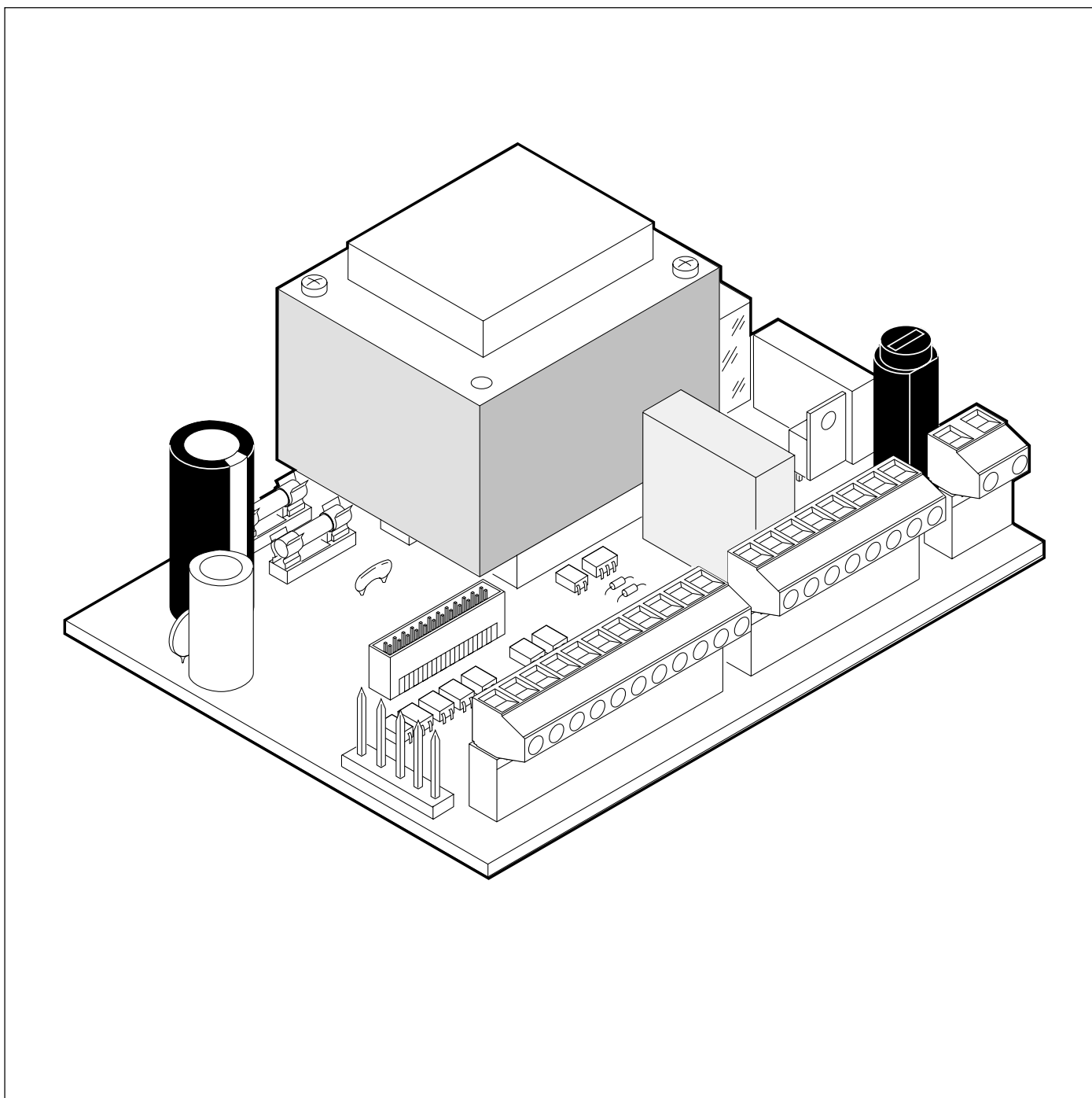

FAAC para la naturaleza
100% papel reciclado



FAAC ist umweltfreundlich
100% Altpapier



FAAC pour la nature
papier recyclé 100%



FAAC for nature
recycled paper 100%



FAAC per la natura
carta riciclata 100%



FAAC



EC MACHINE DIRECTIVE COMPLIANCE DECLARATION

Manufacturer: FAAC S.p.A.

Address: Via Benini, 1
40069 - Zola Predosa
BOLOGNA - ITALY

Hereby declares that: The electronic control unit model 460P

- complies with the essential safety requirements of the following directives :

73/23/EEC and subsequent amendment 93/68/EEC.

89/336/EEC and subsequent amendment 92/31/EEC and 93/68/EEC

Additional note:

These products have undergone tests in a typical uniform configuration (all products manufactured by FAAC S.p.A.).

Bologna, 1 January 1997

Managing
Director

A. Bassi

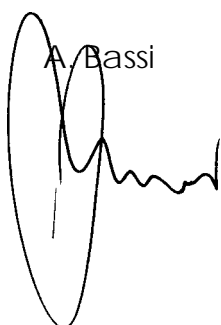

IMPORTANT NOTICE FOR THE INSTALLER

GENERAL SAFETY REGULATIONS

- 1) **WARNING! FAAC strongly recommends to follow these instructions literally for the safety of persons. Improper installation or misuse of the product will cause very serious damages to persons.**
- 2) Packaging material (plastic, polystyrene etc.) is a potential hazard and must be kept out of reach of children.
- 3) Read the instructions carefully before installing the product.
- 4) Keep these instructions for future reference.
- 5) This product has been designed and manufactured only for the use stated in this manual. Any other use not expressly set forth will affect the reliability of the product and/or could be source of hazard.
- 6) FAAC S.p.A. cannot be held responsible for any damage caused by improper use or different from the use for which the automation system is destined to.
- 7) Do not use this device in areas subject to explosion: the presence of flammable gas or fumes is a serious hazard.
- 8) Mechanical constructive elements must comply with UNI8612, CEN pr EN 12604 and CEN pr EN 12605 standards.
Countries outside the EC shall follow the regulations above besides their national normative references in order to offer the utmost safety.
- 9) FAAC cannot be held responsible for failure to observe technical standards in the construction of gates and doors, or for any deformation of the gates which may occur during use.
- 10) Installation must comply with UNI8612, CEN pr EN 12453 and CEN pr EN 12635.
The degree of safety of the automation must be C+E.
- 11) Before carrying out any operations, turn off the system's main switch.
- 12) An omnipower switch shall be provided for the installation with an opening distance of the contacts of 3 mm or more. Alternatively, use a 6A thermomagnetic breaker with multi-pole switching.
- 13) Ensure that there is a differential switch up-line of the electrical system, with a trip threshold of 0.03A.
- 14) Check that the earthing plant is in perfect condition and connect it to the metallic parts. Also earth the yellow/green wire of the operator.
- 15) The automation is fitted with an anti-crush safety system that is a torque control device. In any case, further safety devices shall be installed.
- 16) The safety devices (e.g. photocells, safety edges etc.) protect areas where there is a mechanical movement hazard, e.g. crushing, entrapment and shearing.
- 17) Each installation must be fitted with at least one flashing light (e.g. FAAC LAMP, MINILAMP etc.) as well as a warning plate suitably fixed to the gate, besides the safety devices as per point 16. above.
- 18) FAAC cannot be held responsible regarding safety and correct functioning of the automation in the event that parts other than FAAC original parts are used.
- 19) Use only FAAC original spare parts for maintenance operations.
- 20) Do not carry out any modifications to automation components.
- 21) The installer must supply all information regarding manual operation of the system in the event of an emergency and provide the end-user with the "End-user Guide" attached to the product.
- 22) Keep out of persons when the product is in operation.
- 23) Keep out of reach of children the remote radio controls and any control devices. The automation could be operated unintentionally.
- 24) The end-user must avoid any attempt to repair or adjust the automation personally. These operations must be carried out exclusively by qualified personnel.
- 25) **What is not explicitly stated in these instructions is not permitted.**

1. DESCRIPTION

The 460P is a microprocessor-based programmable electronic control unit for hydraulic operators constructed in SMT technology. It is supplied in a standard configuration which can be modified using the FAACTOTUM programmer.

1.1 TECHNICAL SPECIFICATIONS

Table 1 460P hardware characteristics

Power supply	230 V ~ (+6% -10%) - 50 Hz
Max. absorbed power	35 W
Max. motor load	800 W
Accessories power supply	24 Vdc
Max. accessories load	0.5 A
Warning light power supply	24 Vdc
Max. warning light load	3 W
Temperature range	-20°C +55°C
Fuses	Motors power supply Accessories power supply Logic power supply
Mains filter	Integrated in card
Quick connector	For decoding cards/RP Receiver
Connector	For FAACTOTUM and optional modules
Terminal block outputs	Motor 1 Motor 2 Flashing light Warning light power supply Accessories power supply
Terminal block	Removable

Table 2 Default programming characteristics

Terminal block inputs	Open Open single leaf Stop Closure safeties Opening safeties
Operating logic	Automatic
Opening/closing time	25 seconds
Pause time	25 seconds
Closing leaf delay time	5 seconds
Opening leaf delay time	2 seconds

Table 3 Accessories for 460P

FAACTOTUM	for card programming
GATECODER	deceleration/anti-crushing safety
Optional modules	MEI (input expansion module) MEL1 (electric lock management 1) MEL2 (electric lock management 2)

1.3 LAYOUT

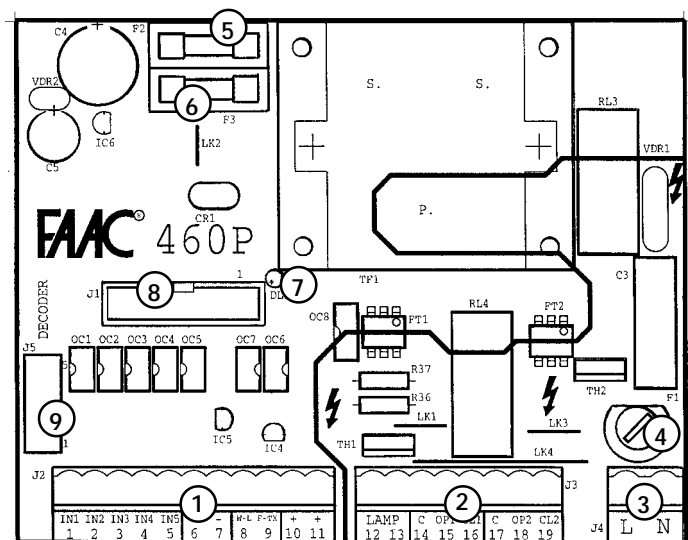

Fig. 1

1.2 PROGRAMMABLE PARAMETERS

Table 4 Parameters that can be programmed with FAACTOTUM

Operating logics:	A-E-S-EP-P-B-C-B/C or customised
Safety operating logics	
Warning light operating logics	
Programmable warning light output	
Available configurable outputs:	Single leaf opening / Complete opening Stop Close Opening/closing safeties Panic device Opening/closing safety edge Leaf 1 and leaf 2 opening/closing limit switch Gatecoder
Programming for operation with TIMER	
Pre-flashing for opening and/or closing	
Independent opening/closing times for each motor	
Pause times	
Opening/closing leaf delay	
Failsafe on safeties	
Electric lock opening/closing management	
Over pushing stroke during opening and/or closing	
Inversion stroke during opening and/or closing	
Electronic deceleration:	timed with limit switches with Gatecoder

The 460P electronic control unit can be installed using the standard configuration and settings the card is supplied with (characteristics are given in Table 2).

The FAACTOTUM programmer must be used if the default configuration requires modification. By using FAACTOTUM it is possible to modify an extremely wide range of parameters to customise card operation according to the requirements and characteristics of the automation.

FAACTOTUM also has a diagnostic function (signalling on the display the state of the gate and inputs in real time and the voltage levels on the card) and verifies operation of the automation and the cycle counts performed.

For details on operation and programming of the FAACTOTUM refer to its instruction manual.

- ① Low-tension **terminal block J2** is used to connect the activating devices and the accessories.
- ② High-tension **terminal block J3** is used to power the motors and the flashing light.
- ③ High-tension **terminal block J4** is used for line voltage input.
- ④ **Fuse F1 5x20 5A/250V rapid** powers motors and transformer primary coil.
- ⑤ **Fuse F2 5x20 1.6A/250V delayed** powers accessories.
- ⑥ **Fuse F3 5x20 315mA/250V delayed** powers logic
- ⑦ **LED DL1** indicates the card power supply (lights up) and any variations in the state of each input (goes out momentarily)
- ⑧ **Connector J1** for inserting optional modules and/or cable for connection to FAACTOTUM.
- ⑨ **Connector J5** for quick connection of DECODER, MINIDEC, RP receiver.

2. ELECTRICAL CONNECTIONS USING STANDARD CONFIGURATION

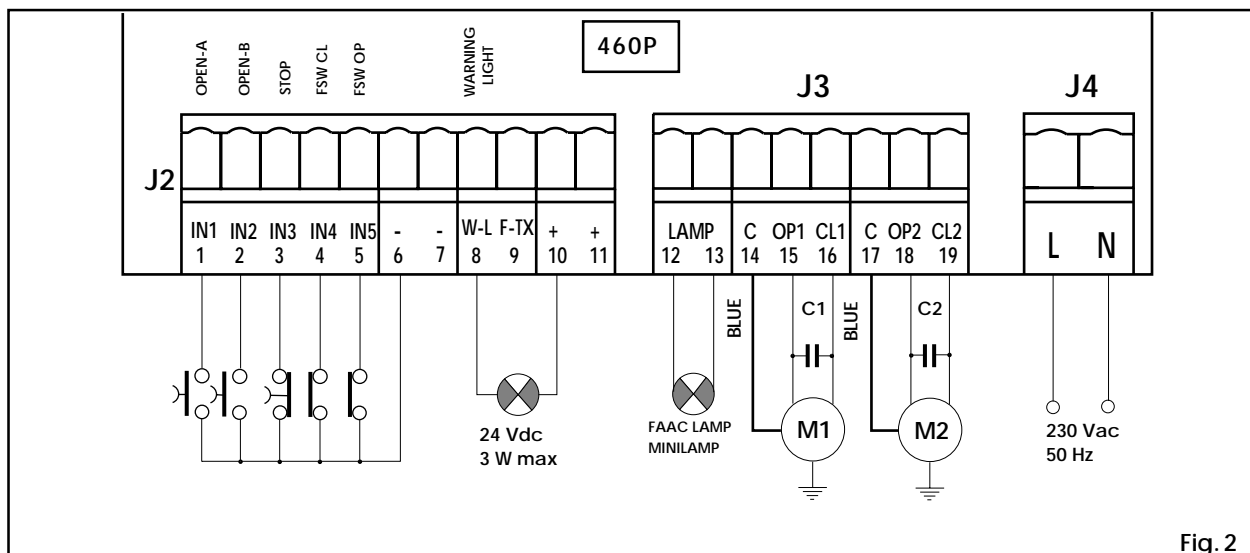

Fig. 2

Terminal block J2 (low tension)

1 - IN1 = OPEN-A command - complete opening (N.O.)

This means any device (pushbutton, detector, etc.) which can give an opening/closing pulse for both gate leaves through the closure of a contact.

To install more than one OPEN-A device connect the N.O. contacts in parallel.

2 - IN2 = OPEN-B command - single leaf opening (N.O.)

This means any device (e.g. pushbutton) which can give an opening/closing pulse for the gate leaf driven by motor M1 through the closure of a contact.

To install more than one OPEN-B device connect the N.O. contacts in parallel.

3 - IN3 = STOP command (N.C.)

This means any device (e.g. pushbutton) which stops the movement of the gate by opening a contact.

To install more than one stop device connect the N.C. contacts in series.

➤ If Stop devices are not connected jumper the input with the common contact (terminal 6 or 7).

Note about safety devices

These are all devices (photocells, safety edges, magnetic coils, etc.) with an N.C. contact which are activated if an obstacle obstructs the area protected by the safety devices and stop the movement of the gate leaves (fig. 3).

➤ If the opening safety devices are activated when the gate is closed, they prevent the leaves from opening.

If the closing safety devices are activated when the gate is open, they prevent the leaves from closing.

4 - IN4 = FSW-CL Closing safety device contact (N.C.)

During closure, activation of the safety devices causes the gate leaves to reverse their direction of movement. They are not activated during opening.

➤ If closure safety devices are not connected, jumper this input to the common contact (terminal 6 or 7).

The function of the closure safety devices is to safeguard the area affected by the movement of the leaves during closure (B, fig. 3).

5 - IN5 = FSW-OP Opening safety device contact (N.C.)

During opening the safety devices stop the movement of the gate leaves. When released they reverse the direction of movement.

➤ If opening safety devices are not connected, jumper this input with the common contact (terminal 6 or 7).

The function of the opening safety devices is to safeguard the area behind the gate leaves (A, fig. 3).

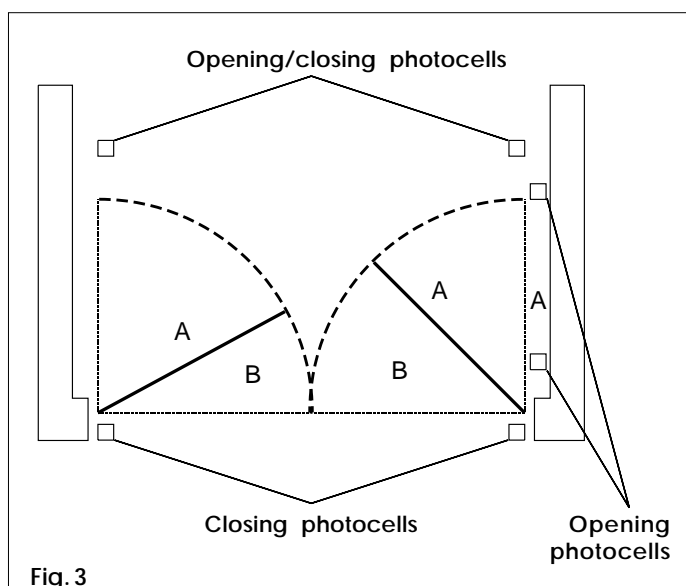

Fig. 3

It is possible to connect devices which operate simultaneously as opening and closing safety devices (see example of safety device connection).

The gate leaves stop if these safety devices are activated during opening, then carry on opening when they are released.

The leaves stop moving if these safety devices are activated during closure, then change direction and open when they are released.

Fig. 3 shows a recommended example of safety device installation.

Examples of application of safety devices and connections
(using the 460P standard configuration)

➔ FAILSAFE disabled

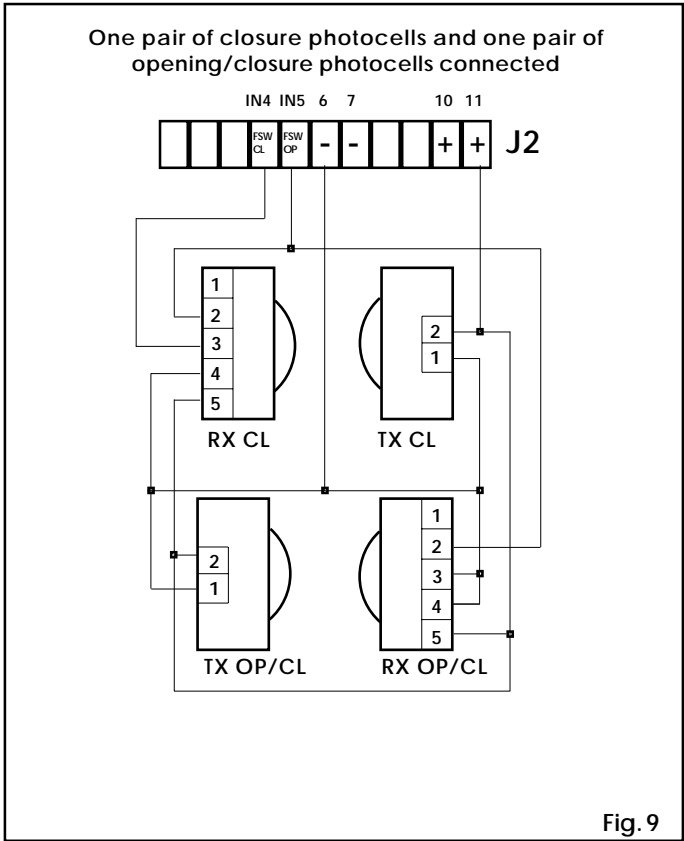
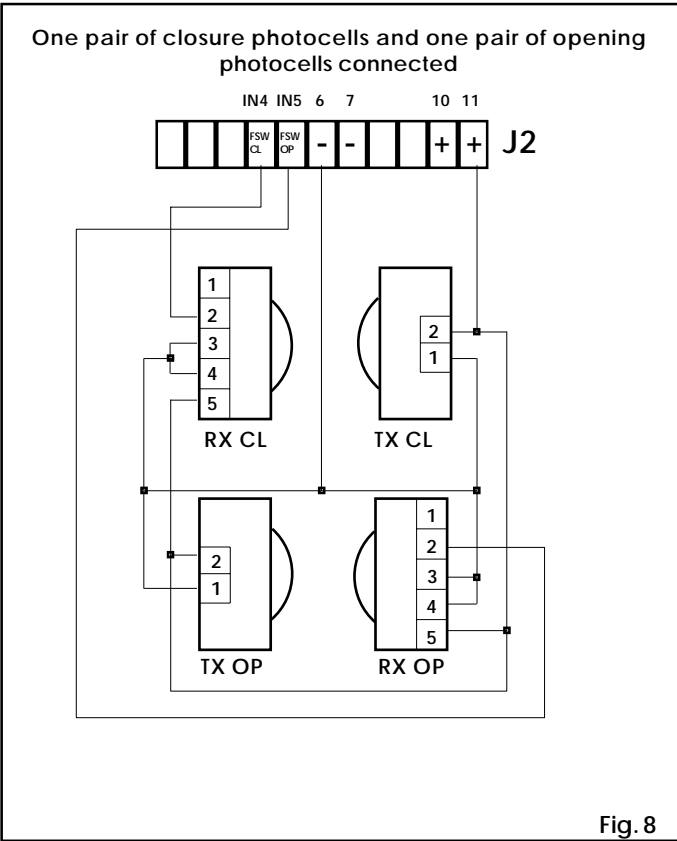
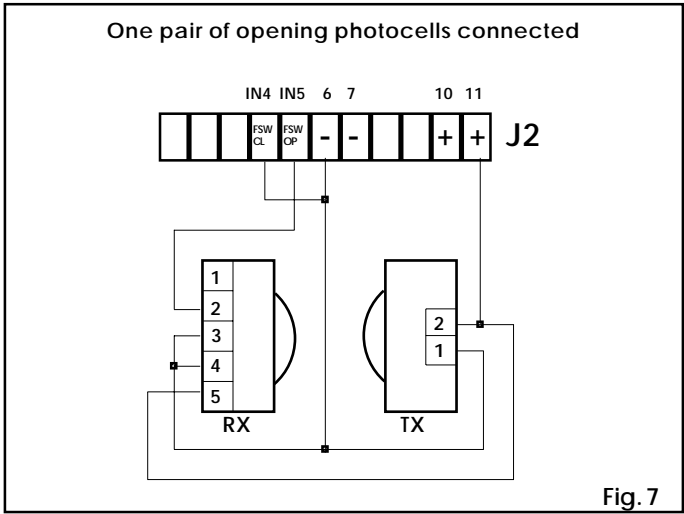
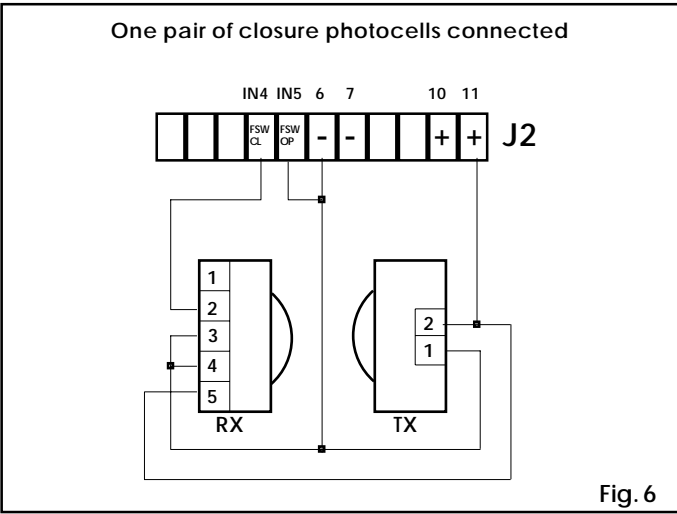
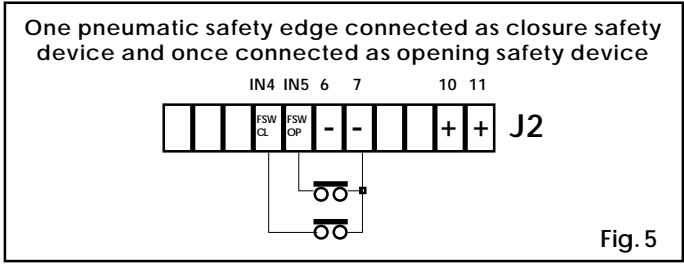
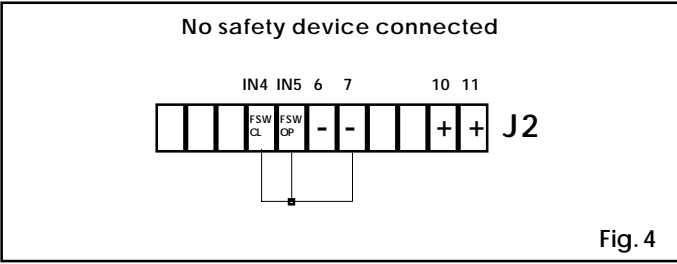

- 6 and 7 - Accessories power supply Common/Negative (-)
 8 - Warning Light (-)
 Warning light power supply negative.
 The warning light (24 Vdc 3 W max.) must be inserted between this terminal and the positive of the accessories power supply (terminal 10 or 11).
 Do not exceed the stated power.

Table 5: Warning light standard operation

GATE STATE	CLOSED	OPEN ON PAUSE	CLOSING	OPENING	STOPPED
WARNINGLIGHT	Off	On	Flashing	On	On

- ➔ The FAACTOTUM can be used to program operation of the warning light output:
- 1) Warninglightsteadyduring closure
 - 2) Courtesy timing
 - 3) Panic device active
 - 4) Open state
 - 5) Opening state
 - 6) Closing state
 - 7) Closed state
 - 8) Stop command active
 - 9) Pause state

9 - F-TX (-)

If the FAILSAFE is used (programming it with the FAACTOTUM), this terminal constitutes the power supply negative for the photocell transmitter.

10 and 11 - Accessories power supply positive (+24 Vdc)
 The maximum accessories load is 500 mA. To calculate absorbed power, refer to table 6.

Table 6 Accessories consumption

TYPE OF ACCESSORY	NOMINAL DRAWN CURRENT
R 31	50 mA
PLUS 433 E	20 mA
MINIDEC SL / DS	6 mA
DECODERSL / DS	20 mA / 55 mA
RP 433 SL / DS	12 mA / 6 mA
DIGICARD	15 mA
METAL DIGIKEY	15 mA
FOTOSWITCH	90 mA
DETECTORF4 / PS6	50 mA
MINIBEAM	70 mA
WARNINGLIGHT	150 mA

Terminal block J3 (high-tension outputs)

- 12 and 13- LAMP (230Vac)
 Terminals for connecting the flashing light (FAAC Lamp, Minilamp)
- 14,15,16 - COM/OP1/CL1 = MOTOR 1
 Connection of Motor 1 (delayed closure)
 COM = motor common (blue cable)
 OP1/CL1 = motor phases
 Motor 1 is activated in single-leaf opening
 Use this output for the single-leaf application
- 17,18,19 - COM/OP2/CL2 = MOTOR 2
 Connection of Motor 2 (delayed opening)
 COM = motor common (blue cable)
 OP2/CL2 = motor phases

Terminal block J4 (high-tension input)

- L - 230Vac power supply (Live)
 N - 230Vac power supply (Neutral)

Connector J5

Connector J5 (9, fig. 1) is used for quick connection of DECODER, MINIDEC and RP Receiver (Figs. 10, 11, 12, 13).
 Connect by inserting the connector on the accessories cards perpendicularly to the corresponding connector J5 on the 460P.
 Turn off the power supply at the electronic control unit before connecting and disconnecting.

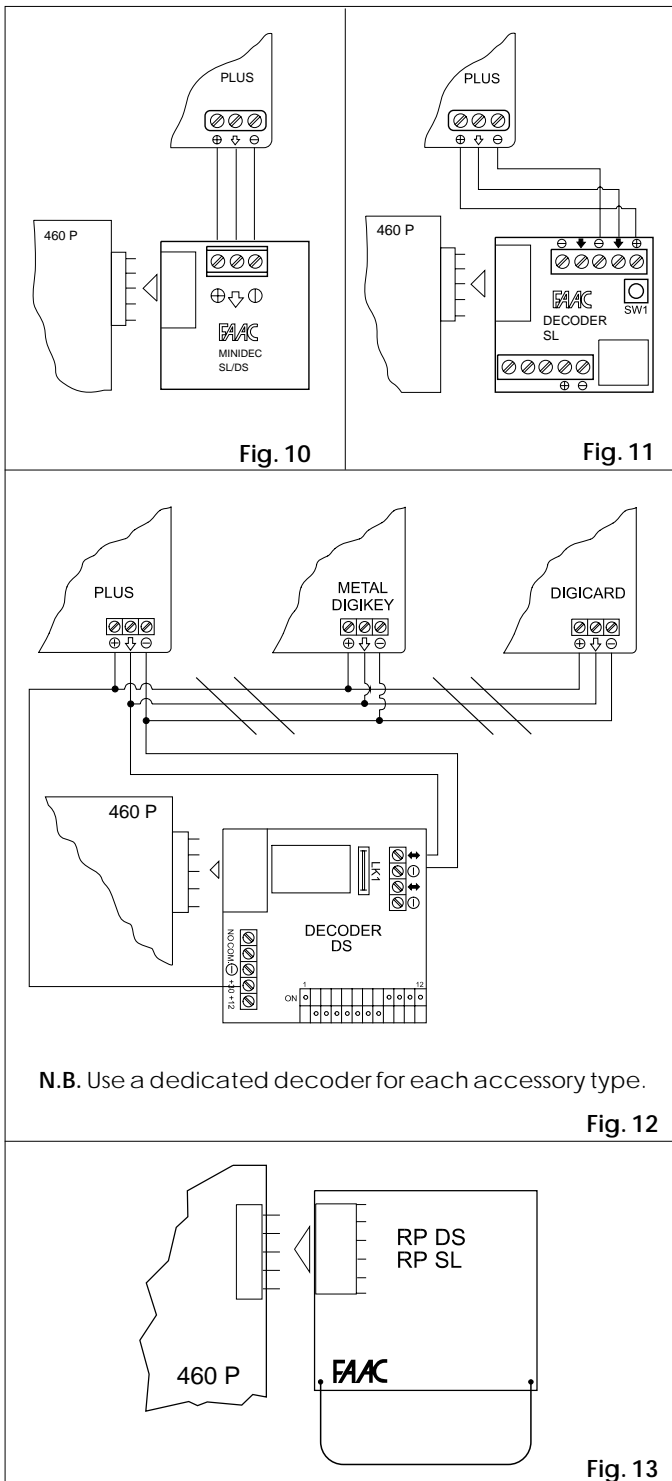

N.B. Use a dedicated decoder for each accessory type.

Connector J1

Optional modules (MEI - MEL1 - MEL2) and/or the FAACTOTUM connection cable must be inserted in connector J1 (Fig. 14). The connector can be fitted one way only so that the module terminal block is oriented in the same direction as the 460P card terminal block. Disconnect power from the card before inserting or removing the modules.

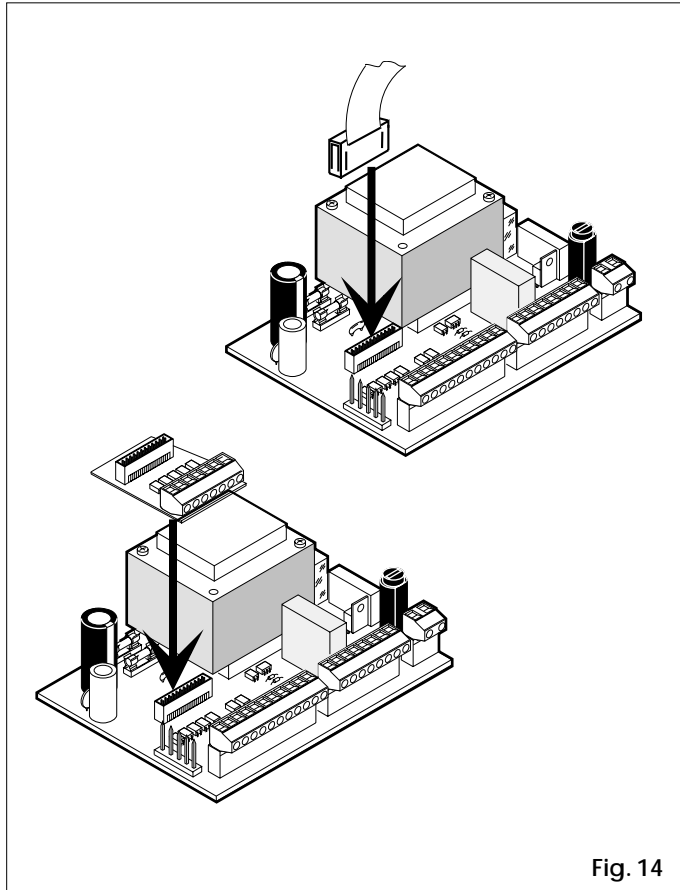

Fig. 14

3. INSTALLATION

Install the electronic control unit in enclosures with adequate housing protection (min. IP55).

The cable holes and tube grips used for wiring must not reduce the housing protection of the enclosure.

The 460P is provided with standard preset programming (the characteristics are given in Table 2). For details of operation, refer to Table 9.

- The inputs CLOSE, SAFE-OP, SAFE-CL and EMERG are available only by installing the input expansion module MEI on the card (it is not necessary to program with the FAACTOTUM).

3.1 CHECKING DIRECTION OF ROTATION

- 1) Turn off power supply to 460P card.
- 2) Move the gate or barrier manually to its halfway open position.
- 3) Lock the operators again.
- 4) Turn the power supply back on.
- 5) Send an opening pulse and check that this opens the leaf or the barrier.

If the first opening pulse closes one or both leaves, invert the electric motor phases (brown and black cables) on the card terminal block for each leaf that closes.

4. OPTIONAL MODULES

The optional modules are additional electronic cards installed on the 460P.

Each module has two connectors: one on the soldered side, the other on the component side.

The connector on the soldered side allows the module to be inserted into card 460P connector J1 or into the connector on the component side of another module.

The connector on the component side can be used to fit another module or the FAACTOTUM connection cable into the module.

The currently available modules are:

MEL-1 : single electric lock management module.

MEL-2 : double electric lock management module.

MEI : input expansion module.

The electric lock management modules must not both be installed on the same 460P card.

One input expansion module (MEI) and one electric lock management module (MEL-1 or MEL-2) can be installed, bearing the following in mind:

The MEI module must be fitted into the 460P card connector J1 and the electric lock management module must be fitted on top of the MEI module.

The connecting cable to the FAACTOTUM must be inserted into the 460P card connector J1 if it is free (i.e. when no other optional module is installed) or into the free connector of the last installed module.

Module MEL-1

The module MEL-1 (Fig. 15) is able to control either just one electric lock or a number of electric locks activated simultaneously (using an external power supply). A free contact is available between terminals 3 (COM) and 4 (N.O.). In the connection diagram shown in Fig. 16, just one 12 Vdc electric lock with 12 ohm internal resistance must be installed.

A different type of electric lock or a number of electric locks in parallel can be installed using an adequate external power supply as shown in the diagram in Fig. 17. In this case do not exceed the maximum permitted contact capacity (5A max.).

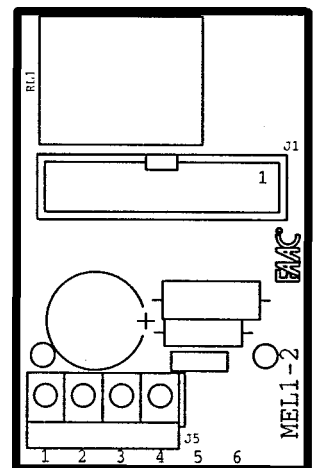

Fig. 15

- The MEL-1 module can be installed on the 460P card without it being necessary to perform any programming when using a closure electric lock.

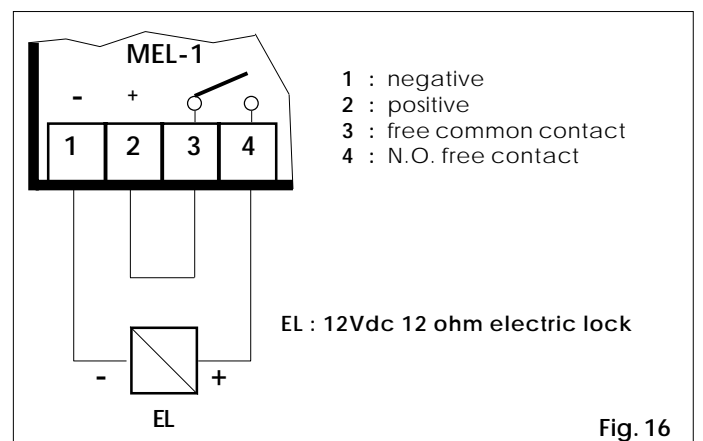

Fig. 16

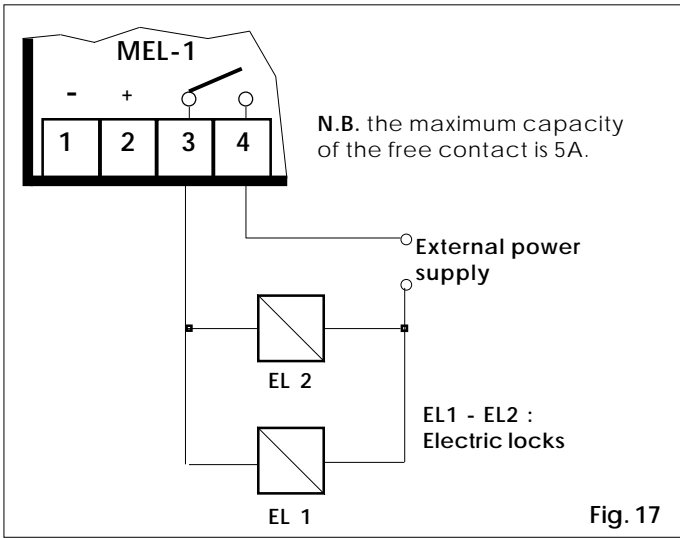

Fig. 17

Closing the contact between terminals 3-4 activates the electric lock(s) present.
 With the FAAC TOTUM it is possible to program this contact to close as follows:

- only when the gate starts to open
- only when the gate starts to close
- when the gate starts to open and when it starts to close.

Module MEL 2

The module MEL-2 (Fig. 18) is able to control 2 inputs for independent electric locks. Two free contacts are available between terminals 3 (COM), 5 (N.O.) and 6 (N.O.).

Following the connection diagram shown in Fig. 19, a maximum of two 12 Vdc electric locks with 12 ohm internal resistance can be installed.

It is possible to install different types of electric locks or a number of electric locks in parallel using external power sources following the connection diagram shown in Fig. 20.

In this case do not exceed the maximum allowed capacity of the contacts (2 A max.).

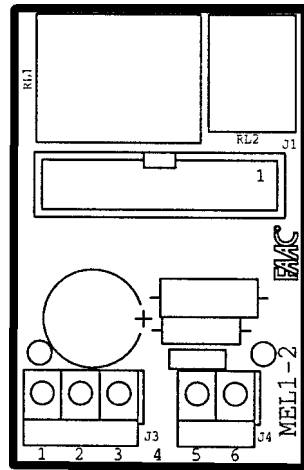

Fig. 18

Single-leaf automation

In single-leaf automation the **closure** electric lock (Fig. 19) or electric locks (Fig. 20) must be connected to terminal 6, while the **opening** electric lock (Fig. 19) or electric locks (Fig. 20) must be connected to terminal 5.

Double-leaf automation

In double-leaf automation the electric lock (Fig. 19) or electric locks (Fig. 20) of leaf 1 (connected to motor M1) must be connected to terminal 6, while the electric lock (Fig. 19) or electric locks (Fig. 20) of leaf 2 (connected to motor M2) must be connected to terminal 5.

Closing the contacts between terminals 3-5 and 3-6 activates the electric lock(s) connected to them.

By using the FAAC TOTUM these contacts can be programmed to close as follows:

- only when the gate starts to open
- only when the gate starts to close
- when the gate starts to open and when it starts to close.

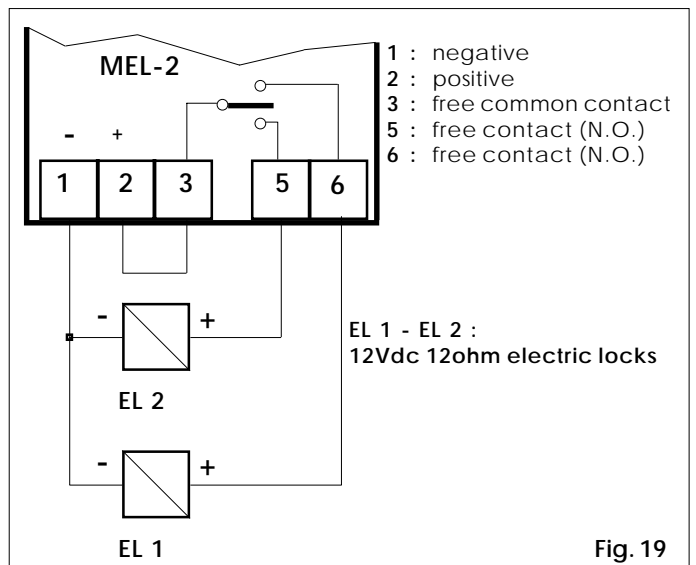

Fig. 19

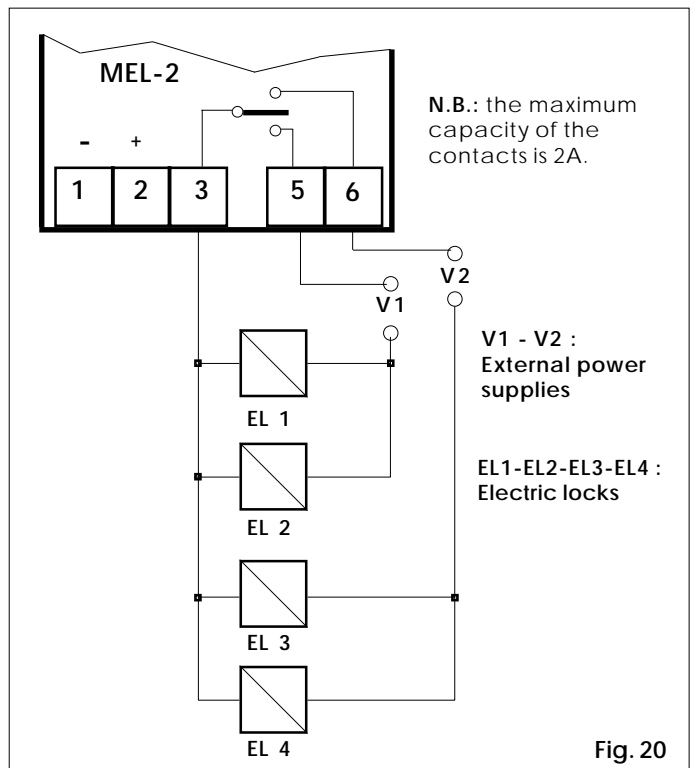

Fig. 20

MEI module

The MEI module (Fig. 21) is an electronic input expansion card. It must be inserted in the 460P card connector J1. It must not be installed on top of any electric lock management modules already present in the connector J1.

On the MEI module there are 6 additional inputs with respect to the standard 5 of the 460P electronic card described above.

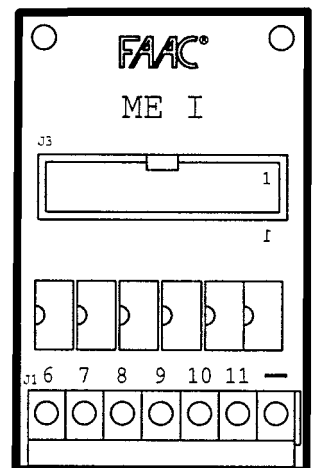

Fig. 21

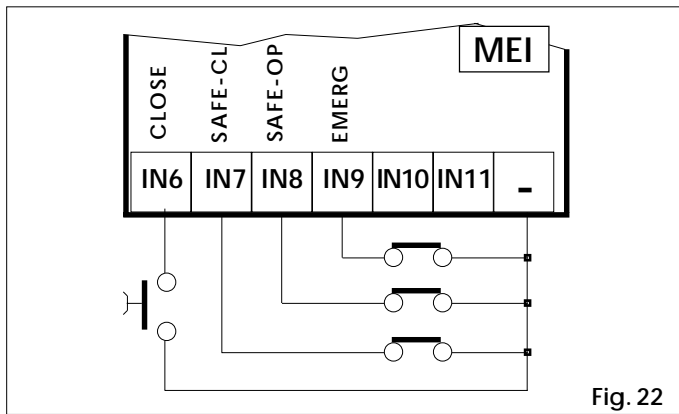

Fig. 22

The MEI module can be installed without any need for programming (except for the inputs reserved for the Gatecoder/ Limit Switch, which must be configured). Be sure to observe the allocation of the default inputs below:

- IN6 - CLOSE = Closure command (N.O.)**
This means any device (e.g. pushbutton) which gives a command to close the leaf/leaves when a contact is closed in "deadman" logic. In the other logics, when the gate is open, on pause or stopped, it gives the command to close the leaf/leaves while it is inactive with the gate closed or opening.
- IN7 - SAFE CL = Safety edge closing (N.C.)**
This input is specifically for connecting pneumatic safety edges which intervene during the closure phase.
Opening this contact during the closure phase causes timed inversion (2 sec. subject to modification) and then stops the movement.
➔ If no devices are connected, jumper this input to the negative (terminal "-" of MEI module if the Failsafe is disabled, terminal 9 of 460P if the Failsafe is enabled).
- IN8 - SAFE OP = Safety edge opening (N.C.)**
This input is specifically for connecting pneumatic safety edges which intervene during the opening phase.
Opening this contact during the opening phase causes timed inversion (2 sec. subject to modification) and then stops the movement.
➔ If no devices are connected, jumper this input to the negative (terminal "-" of MEI module if the Failsafe is disabled, terminal 9 of 460P if the Failsafe is enabled).
It is possible to connect devices which activate simultaneously, such as opening and closing safety edges (see connection examples in section 8).
If these safety devices activate during opening or closing, they stop the gate.
For details of operation, refer to Table 9.
- IN9 - EMERG = Panic device (N.C.)**
This means any device (e.g. pushbutton) which immediately opens the gate or barrier when a contact is opened regardless of the state of the other inputs.
Once the panic opening command has been given, normal operation can be resumed only by resetting the contact and turning the electronic control unit off and then back on again.
➔ If no devices are connected, jumper this input to the negative (terminal "-" of MEI module).

- IN10 - GC1/FCA1 = Gatecoder 1 / Opening limit switch 1**
This input varies according to the programming performed (use of Gatecoder or Limit switch):
Gatecoder used = GC1
This is the input for the signal coming from the Gatecoder installed on the leaf connected to the motor M1 (LEAF 1).
Limit switch used = FCA1 (N.C.)
Input for Leaf 1 opening limit switch contact. The limit switch is a device with an N.C. contact which slows down the leaf connected to motor M1 (LEAF 1) if the contact opens during the leaf opening phase.
Gatecoder and Limit switch not used
In this case the input is not active.
- IN 11 - GC2/FCC1 = Gatecoder 2 / Closure Limit Switch 1**
This input varies according to the programming performed (use of Gatecoder or Limit switch):
Gatecoder used = GC2
This is the input for the signal coming from the Gatecoder installed on the leaf connected to motor M2 (LEAF 2).
Limit switch used = FCC 1 (N.C.)
Input for Leaf 1 closure limit switch contact. The limit switch is a device with an N.C. contact which slows down the leaf connected to motor M1 (LEAF 1) if the contact opens during the leaf opening phase.
Gatecoder and Limit switch not used
In this case the input is not active.

5. GATECODER

The Gatecoder is an electronic detector that reads in real time the exact position of the leaf for the gate on which it is installed. Two-leaf gates require a Gatecoder for each leaf. The GATECODER is compatible only with the 460P card.

Table 7 GATECODER technical characteristics

Power supply	24Vdc
Housing protection	IP 66
Ambient temperature	-20 °C +55 °C
Connection to 460P	3x0.35 mm ² cable length 1 metre
Functions	Deceleration/anti-crushing
Installable on operators	402-422-400

By using a learning cycle during the 460P card programming phase, the Gatecoder slows down the leaf at the desired point during both closing and opening.
Furthermore the Gatecoder also constitutes an effective electronic anti-crushing safety device (which can be disabled) because if an obstacle is detected while the leaf is moving it reverses the direction of movement.
The obstacle detection time before reversal of movement is programmable (standard 1 sec.).

5.1 INSTALLATION

Refer to Fig. 23.

- 1) Insert the Gatecoder support fork (1) into the operator fitting rear bracket. The tongue (2) must be facing the post.
- 2) Fit the operator support fork to the bracket, inserting the pin (4) in such a way that the hexagonal part of the pin engages in the hexagonal seat on the fork. Lock by tightening the nut.
- 3) Thread the connecting cable (6) through the hole on the bracket as shown in the diagram.
- 4) Insert the GATECODER pin into the long pin housing, making sure that the flat part is matched up with the securing dowel (5).
At the same time insert the tongue (2) on the fork (1) into the Gatecoder housing.

- 5) Tighten the dowel (5).
- 6) Connect the GATECODER to the 460P card.
- Even if the Gatecoder is used, opening and closing mechanical stops are required for correct operation of the automation.

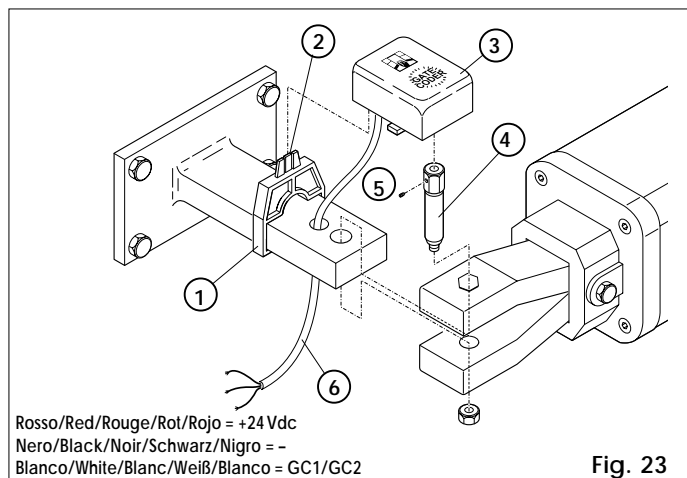

Fig. 23

6. INPUT MANAGEMENT (requires FAACTOTUM)

The 460P is able to control the following inputs:

Table 8

No.	Input	Description	Type
1	OPEN-A	total leaf opening	N.O.
2	OPEN-B	single leaf opening	N.O.
3	STOP	stops movement	N.C.
4	FSW-CL	closure safety photocells	N.C.
5	FSW-OP	opening safety photocells	N.C.
6	CLOSE	closure command	N.O.
7	SAFE-CL	closure safety edge	N.C.
8	SAFE-OP	opening safety edge	N.C.
9	EMERG	panic device	N.C.
10/a	GC1	Gatecoder leaf 1	signal
11/a	GC2	Gatecoder leaf 2	signal
10/b	FCA1	leaf 1 opening limit switch	N.C.
11/b	FCC1	leaf 1 closing limit switch	N.C.
12	FCA2	leaf 2 opening limit switch	N.C.
13	FCC2	leaf 2 closing limit switch	N.C.

- Leaf 1 is the leaf connected to motor M1
- Leaf 2 is the leaf connected to motor M2

On the 460P and the MEI module the terminal block inputs are assigned by default. The FAACTOTUM can be used during the programming phase to change the assigned inputs according to the rules given below.

460P without MEI module

The 5 inputs on the 460P card available by default are given in Fig. 24.

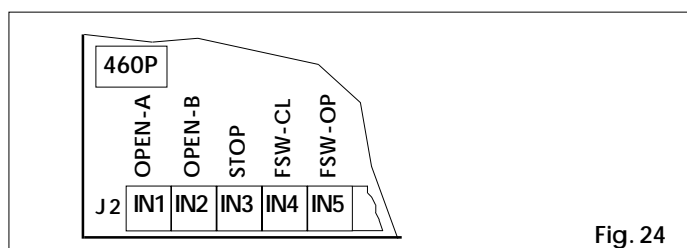

Fig. 24

➤ Limitations in assigning of inputs:

- 1) The terminal IN1 (OPEN-A) does not appear in the assigning cycle because it cannot be changed.
- 2) Terminals IN2-IN5 can be assigned different functions to the default functions, chosen from inputs nos. 6-13 given in table 8.
- 3) Limit switches cannot be used at the same time as the Gatecoder and vice versa.
- 4) With the sole exception given below, it is not possible to assign the same function to more than one terminal.
- 5) The 460P card terminal IN2 can also be configured as a second OPEN-A input so that if an opening control device shorts on one of the two inputs, the devices connected to the other input continue to control the automation as normal.
- 6) It is not possible to move an input which already has an assigned default terminal on the 460P card (e.g. the STOP function cannot be assigned to terminal IN5 on the 460P card).
- 7) Each terminal, with the exception of IN1 and IN2, can be deactivated by selecting the "INACT" function in the input assigning cycle.

460P with MEI module

The 5 inputs on the 460P card plus the 6 inputs of the MEI module available by default are shown in Fig. 25.

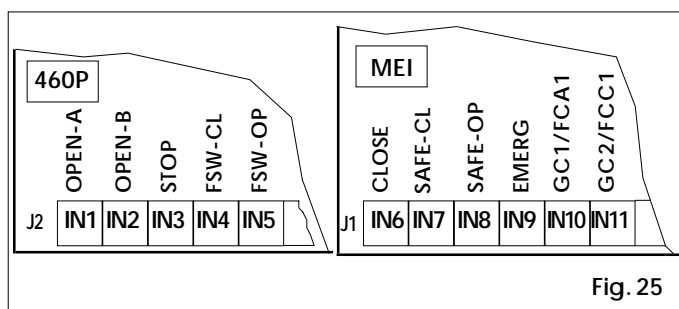

Fig. 25

The inputs IN6-IN9 are active without the need for programming using the FAACTOTUM. Simply insert the MEI module into the 460P with the standard configuration.

➤ Limitations in assigning of inputs:

- 1) The terminal IN1 (OPEN-A) does not appear in the assigning cycle because it cannot be changed.
- 2) Terminals IN10-IN11 do not appear in the assigning cycle because they are set directly by the FAACTOTUM according to the selections made during programming (use of Gatecoder or limit switches). If neither the Gatecoder or the limit switches are used they are inactive.
- 3) If the limit switches are used, terminals IN2-IN9 can be assigned different functions to those set by default, chosen among inputs 12-13 given in table 8.
- 4) Limit switches cannot be used at the same time as the Gatecoder and vice versa.
- 5) With the sole exception given below, it is not possible to assign the same function to more than one terminal.
- 6) The 460P card terminal IN2 can also be configured as a second OPEN-A input so that if an opening control device shorts on one of the two inputs, the devices connected to the other input continue to control the automation as normal.
- 7) It is not possible to move an input which already has an assigned default terminal on the 460P card or the MEI module (e.g. the STOP function cannot be assigned to terminal IN5 on the 460P card).
- 8) Each terminal, with the exception of IN1, IN2, IN10 and IN11, can be deactivated by selecting the "INACT" function in the input assigning cycle.

Table 9 Standard automatic operating logic

LOGIC "A"	PULSES									
	OPEN-A	OPEN-B	CLOSE	STOP	FSW-OP	FSW-CL	FSW-OP/CL	SAFE-OP	SAFE-CL	SAFE-OP/CL
CLOSED	opens leaves and recloses after pause time	opens single leaf and recloses after pause time	no effect	no effect (OPEN inhibited)	no effect (OPEN inhibited)	no effect	no effect (OPEN inhibited)	no effect (OPEN inhibited)	no effect	no effect (OPEN inhibited)
OPENING	no effect (1)	no effect	no effect	stops	stops opening and when disengaged closes	no effect	stops opening and when disengaged continues to open	reverses movement for 2 seconds then stops	no effect	stops movement ▶ when disengaged OPEN= closes (1) CLOSE= closes
OPEN ON PAUSE	recloses leaves immediately (1)	recloses leaf/leaves immediately	recloses leaf/leaves immediately	stops	no effect -opening inhibited-	freezes pause until disengagement -closure inhibited-	freezes pause until disengagement (2) -OPEN/CLOSE inhibited-	no effect -opening inhibited-	no effect -closure inhibited-	no effect (OPEN/CLOSE inhibited)
CLOSING	reopens leaves immediately	reopens leaf/leaves immediately	no effect	stops	no effect	changes direction and starts to open	stops and when disengaged starts to open	no effect	reverses movement for 2 seconds then stops	stops movement ▶ when disengaged OPEN= opens CLOSE= closes
STOPPED	closes the leaves (1)	closes the leaf/leaves	closes leaf/leaves	no effect (OPEN/CLOSE inhibited)	no effect -opening inhibited-	no effect -closure inhibited-	no effect (OPEN/CLOSE inhibited)	no effect -opening inhibited-	no effect -closure inhibited-	no effect (OPEN/CLOSE inhibited)

↪ The effects of an active impulse on the other inputs is given in brackets.

(1) An OPEN-A impulse during a pedestrian cycle (OPEN-B), activates both leaves in opening.

(2) If residual pause time is shorter than 5 seconds, it closes after 5 seconds when the safeties are disengaged.

7. FAILSAFE

FAILSAFE is a system for checking the functionality of the photocells.

The check is always performed before the motors are started. It turns off the power supply temporarily to the photocell transmitter and checks that this causes the contact on the receiver to open. If it does not, movement of the leaves is inhibited for safety reasons. To enable the FAILSAFE it must be set during the programming phase.

Using the FAILSAFE requires a separate power supply for the photocell transmitter (see Figs. 26, 27, 28, 29, 30, 31)

Examples of applications of safety devices and connections
(with FAILSAFE enabled on inputs FSW-CL and FSW-OP)

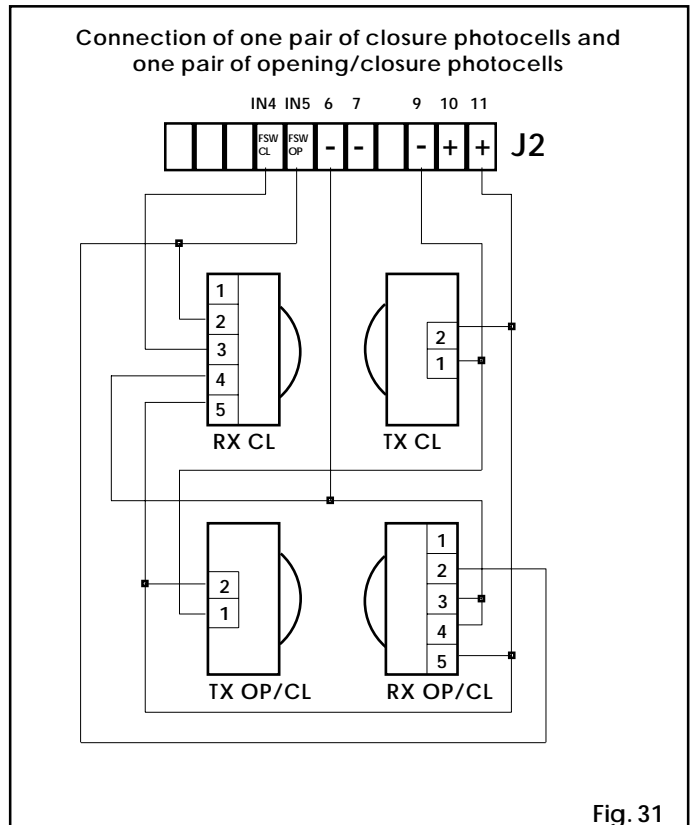
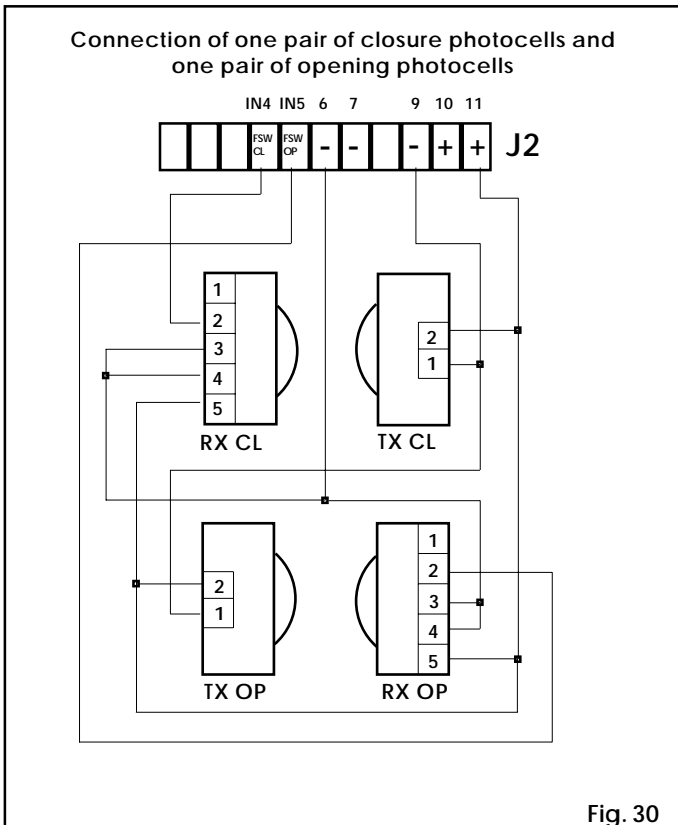
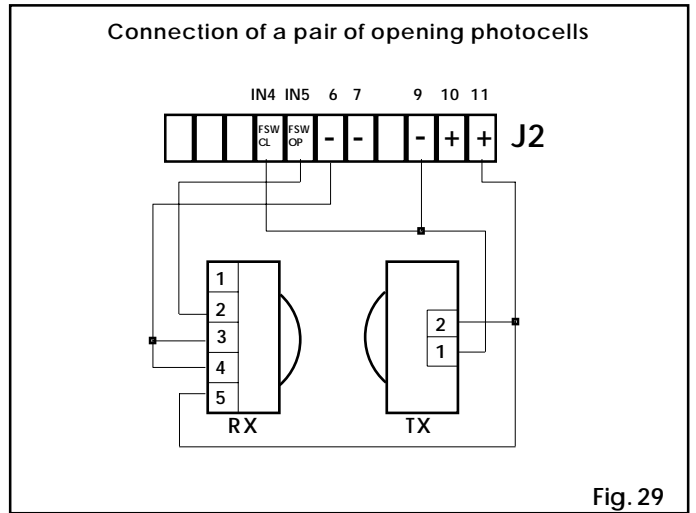
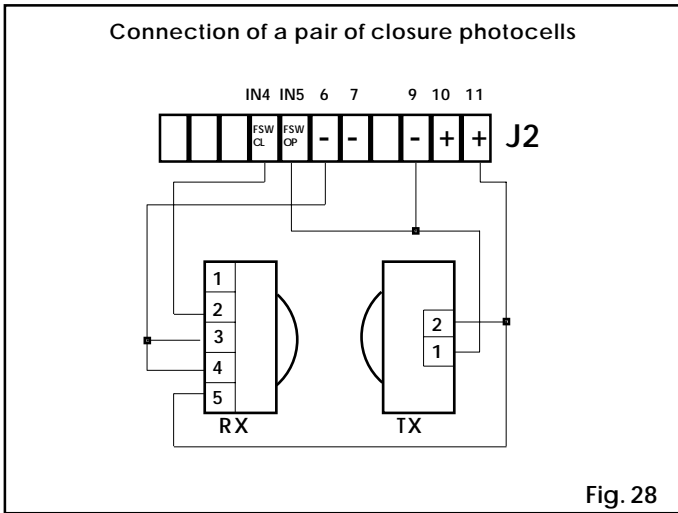
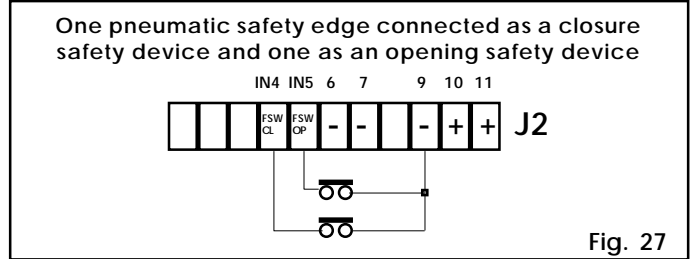
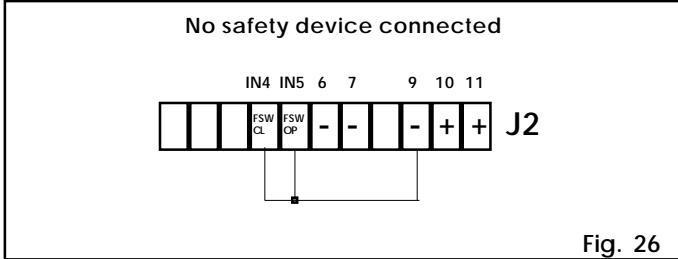

8. CONNECTION EXAMPLES ON SAFE-OP AND SAFE-CL INPUTS
(using 460P standard configuration and MEI module)

► FAILSAFE disabled

No safety device connected

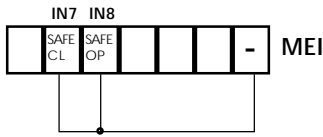

An opening pneumatic safety edge (SAFE OP) and a closing pneumatic safety edge (SAFE-CL) connected

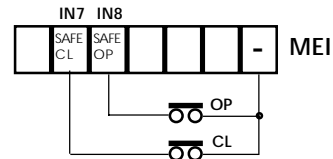

A pair of photocells connected to SAFE-CL input

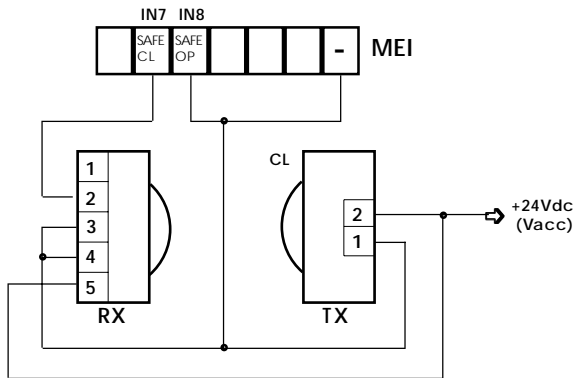

A pair of photocells connected to SAFE-OP input

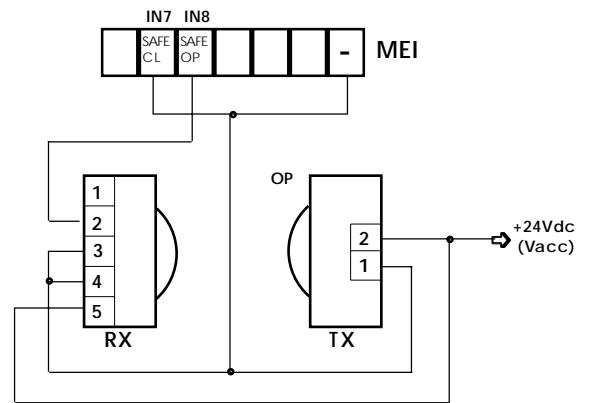

An opening/closing pneumatic safety edge connected (SAFE OP/CL)

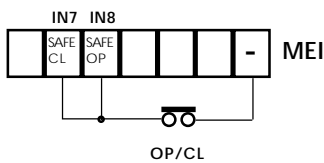

A pair of opening/closing photocells connected (SAFE OP/CL)

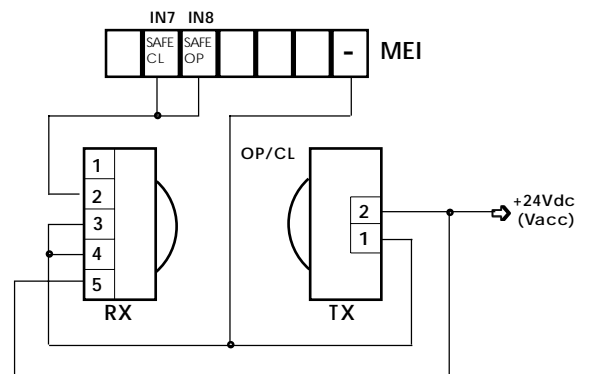

A closing pneumatic safety edge (SAFE CL) and a pair of opening/closing photocells (SAFE OP/CL) connected

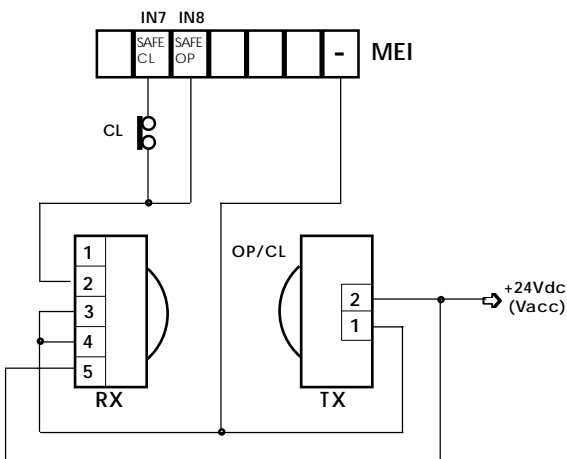

A closing pneumatic safety edge (SAFE CL) and an opening/closing pneumatic safety edge (SAFE OP/CL) connected

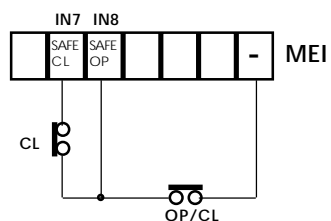



SYSTEM CONFIGURATION

INPUT No.	STANDARD assigning	Customised assigning	
460P	1	OPEN-A	OPEN-A
	2	OPEN-B	
	3	STOP	
	4	FSW-CL	
	5	FSW-OP	
MEI	6	CLOSE	
	7	SAFE-CL	
	8	SAFE-OP	
	9	EMERG	
	10	/	
	11	/	

Pause time	
OP. delay time	
CL. delay time	

Standard logic :

A S E EP P

B C B/C

Customised logic : _____

Failsafe :

FSW-CL FSW-OP

SAFE-CL SAFE-OP

Deceleration:

timed

with limit switch

with Gatecoder

Programming Name: _____

- | | | |
|---|---|--|
| <input type="checkbox"/> Opening pre-flashing | <input type="checkbox"/> Opening inversion stroke | <input type="checkbox"/> Opening over pushing stroke |
| <input type="checkbox"/> Closure pre-flashing | <input type="checkbox"/> Closure inversion stroke | <input type="checkbox"/> Closure over pushing stroke |

Installation date: _____

Installer: _____

Notes :

Le descrizioni e le illustrazioni del presente manuale non sono impegnative. La FAAC si riserva il diritto, lasciando inalterate le caratteristiche essenziali dell'apparecchiatura, di apportare in qualunque momento e senza impegnarsi ad aggiornare la presente pubblicazione, le modifiche che essa ritiene convenienti per miglioramenti tecnici o per qualsiasi altra esigenza di carattere costruttivo o commerciale.

The descriptions and illustrations contained in the present manual are not binding. FAAC reserves the right, whilst leaving the main features of the equipments unaltered, to undertake any modifications it holds necessary for either technical or commercial reasons, at any time and without revising the present publication.

Les descriptions et les illustrations du présent manuel sont fournies à titre indicatif. FAAC se réserve le droit d'apporter à tout moment les modifications qu'elle jugera utiles sur ce produit tout en conservant les caractéristiques essentielles, sans devoir pour autant mettre à jour cette publication.

Die Beschreibungen und Abbildungen in vorliegendem Handbuch sind unverbindlich. FAAC behält sich das Recht vor, ohne die wesentlichen Eigenschaften dieses Gerätes zu verändern und ohne Verbindlichkeiten in Bezug auf die Neufassung der vorliegenden Anleitungen, technisch bzw. konstruktiv/kommerziell bedingte Verbesserungen vorzunehmen.

Las descripciones y las ilustraciones de este manual no comportan compromiso alguno. FAAC se reserva el derecho, dejando inmutadas las características esenciales de los aparatos, de aportar, en cualquier momento y sin comprometerse a poner al día la presente publicación, todas las modificaciones que considere oportunas para el perfeccionamiento técnico o para cualquier otro tipo de exigencia de carácter constructivo o comercial.

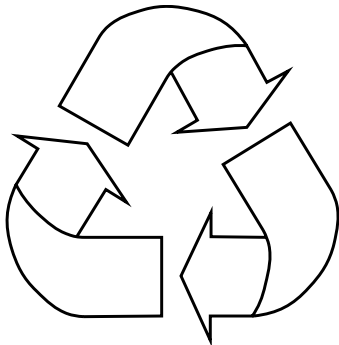

FAAC per la natura

- La presente istruzione è realizzata al 100% in carta riciclata.
- Non disperdete nell'ambiente gli imballaggi dei componenti dell'automazione bensì selezionate i vari materiali (es. cartone, polistirolo) secondo prescrizioni locali per lo smaltimento rifiuti e le norme vigenti.

FAAC for the environment

- The present manual is produced in 100% recycled paper
- Respect the environment. Dispose of each type of product packaging material (card, polystyrene) in accordance with the provisions for waste disposal as specified in the country of installation.

FAAC der Umwelt zuliebe

- Vorliegende Anleitungen sind auf 100% Altpapier gedruckt.
- Verpackungstoffe der Antriebskomponenten (z.B. Pappe, Styropor) nach den einschlägigen Normen der Abfallwirtschaft sortenrein sammeln.

FAAC écologique

- La présente notice a été réalisée 100% avec du papier recyclé.
- Ne pas jeter dans la nature les emballages des composants de l'automatisme, mais sélectionner les différents matériaux (ex.: carton, polystyrène) selon la législation locale pour l'élimination des déchets et les normes en vigueur.

FAAC por la naturaleza

- El presente manual de instrucciones se ha realizado, al 100%, en papel reciclado.
- Los materiales utilizados para el embalaje de las distintas partes del sistema automático (cartón, poliestireno) no deben tirarse al medio ambiente, sino seleccionarse conforme a las prescripciones locales y las normas vigentes para el desecho de residuos sólidos.



FAAC

FAAC S.p.A.
Via Benini, 1
40069 Zola Predosa (BO) - ITALIA
Tel.: 051/6172411 - Tlx.: 521087
Fax: 051/758518

Timbro del Rivenditore:/Distributor's Stamp:/Timbre de l'Agent:/ Fachhändlerstempel:/Sello del Revendedor: