

412

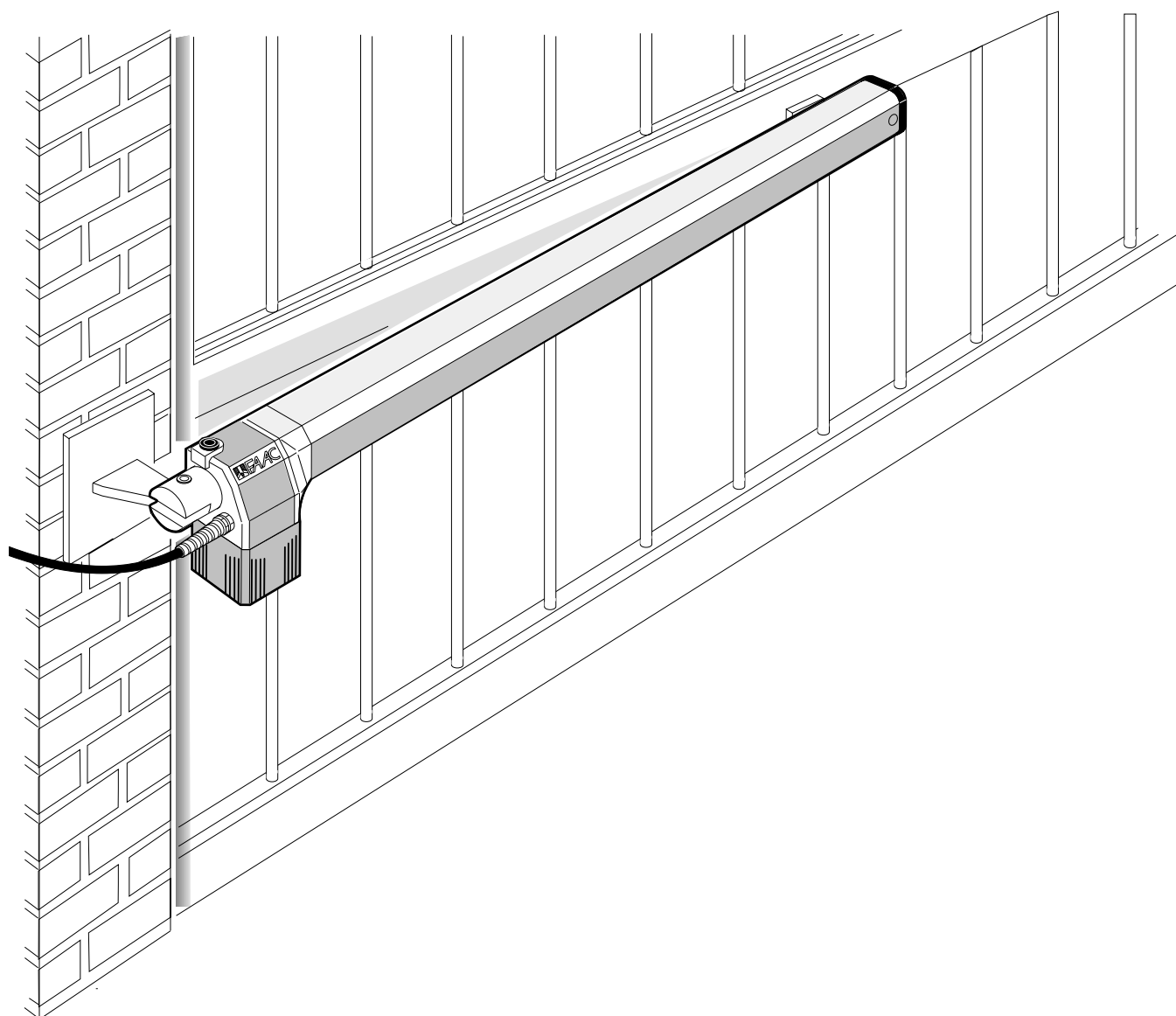

FAAC

EC DECLARATION OF CONFORMITY FOR MACHINES

(DIRECTIVE 2006/42/EC)

Manufacturer: FAAC S.p.A.

Address: Via Benini, 1 - 40069 Zola Predosa BOLOGNA - ITALY

Declares that: Operator mod. 412

is built to be integrated into a machine or to be assembled with other machinery to create a machine under the provisions of Directive 98/37/EC;

conforms to the essential safety requirements of the following EEC directives:

2006/95/EC Low Voltage Directive

2004/108/EC Electromagnetic Compatibility Directive

and also declares that it is prohibited to put into service the machinery until the machine in which it will be integrated or of which it will become a component has been identified and declared as conforming to the conditions of Directive 2006/42/EEC and subsequent amendments.

Bologna, 01-01-2009

The Managing Director
A. Marcellan



WARNINGS FOR THE INSTALLER

GENERAL SAFETY OBLIGATIONS

- 1) **ATTENTION! To ensure the safety of people, it is important that you read all the following instructions. Incorrect installation or incorrect use of the product could cause serious harm to people.**
- 2) Carefully read the instructions before beginning to install the product.
- 3) Do not leave packing materials (plastic, polystyrene, etc.) within reach of children as such materials are potential sources of danger.
- 4) Store these instructions for future reference.
- 5) This product was designed and built strictly for the use indicated in this documentation. Any other use, not expressly indicated here, could compromise the good condition/operation of the product and/or be a source of danger.
- 6) FAAC declines all liability caused by improper use or use other than that for which the automated system was intended.
- 7) Do not install the equipment in an explosive atmosphere: the presence of inflammable gas or fumes is a serious danger to safety.
- 8) The mechanical parts must conform to the provisions of Standards EN 12604 and EN 12605.
For non-EU countries, to obtain an adequate level of safety, the Standards mentioned above must be observed, in addition to national legal regulations.
- 9) FAAC is not responsible for failure to observe Good Technique in the construction of the closing elements to be motorised, or for any deformation that may occur during use.
- 10) The installation must conform to Standards EN 12453 and EN 12445.
For non-EU countries, to obtain an adequate level of safety, the Standards mentioned above must be observed, in addition to national legal regulations.
- 11) Before attempting any job on the system, cut out electrical power.
- 12) The mains power supply of the automated system must be fitted with an all-pole switch with contact opening distance of 3 mm or greater. Use of a 6A thermal breaker with all-pole circuit break is recommended.
- 13) Make sure that a differential switch with threshold of 0.03 A is fitted upstream of the system.
- 14) Make sure that the earthing system is perfectly constructed and connect metal parts of the closure to it.
- 15) The automated system is supplied with an intrinsic anti-crushing safety device consisting of a torque control. Nevertheless, its tripping threshold must be checked as specified in the Standards indicated at point 10.
- 16) The safety devices (EN 12978 standard) protect any danger areas against **mechanical movement Risks**, such as crushing, dragging, and shearing.
- 17) Use of at least one indicator-light (e.g. FAACLIGHT) is recommended for every system, as well as a warning sign adequately secured to the frame structure, in addition to the devices mentioned at point "16".
- 18) FAAC declines all liability as concerns safety and efficient operation of the automated system, if system components not produced by FAAC are used.
- 19) For maintenance, strictly use original parts by FAAC.
- 20) Do not in any way modify the components of the automated system.
- 21) The installer shall supply all information concerning manual operation of the system in case of an emergency and shall hand over to the user the warnings handbook supplied with the product.
- 22) Do not allow children or adults to stay near the product while it is operating.
- 23) Keep remote controls or other pulse generators away from children, to prevent the automated system from being activated involuntarily.
- 24) Transit is permitted only when the automated system is idle.
- 25) The user must not attempt any kind of repair or direct action whatever and contact qualified personnel only.
- 26) Check at least every 6 months the efficiency of the system, particularly the efficiency of the safety devices (including, where foreseen, the operator thrust force) and of the release devices.
- 27) **Anything not expressly specified in these instructions is not permitted.**

412 AUTOMATION SYSTEM

These instructions apply to the following models:

Operators 412 and 412-24V

The FAAC 412 AUTOMATION SYSTEM for swing gates comprises two electromechanical operators which drive the gate leaves by means of a worm screw.

The system locks mechanically; therefore no electric lock is required.

➔ **To obtain anti-crushing protection, you have to use electronic control units with a torque control electronic device. The 412 automation was designed and manufactured to control access of vehicles. Avoid any other use whatever.**

1. DESCRIPTION AND TECHNICAL SPECIFICATIONS

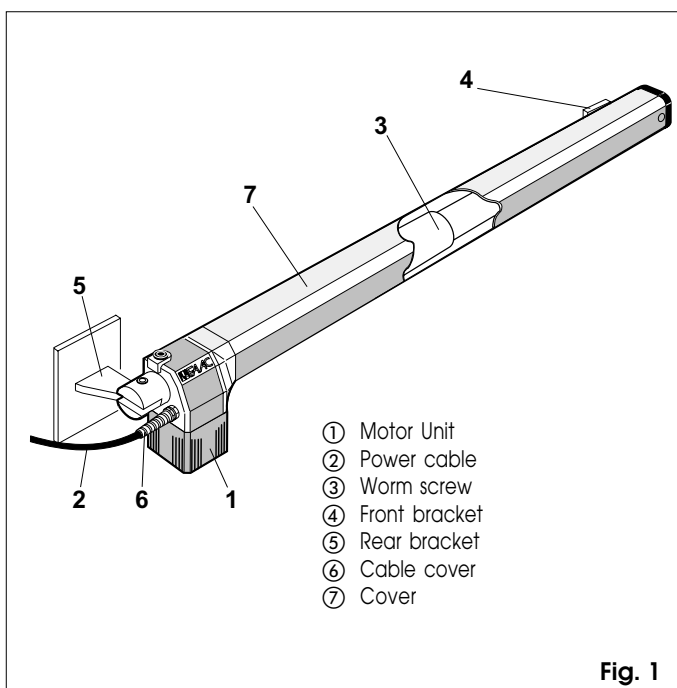

Fig. 1

Table 1: 412 operator technical specifications

	412	412-24V
Power supply	230 V~ 50 Hz	24Vdc
Absorbed power (W)	280	70
Current drawn (A)	1,5	3
Electric motor	1400 rpm	
Motor winding thermal cutout	140 °C	/
Capacitor	8 µF/400V	/
Max. thrust/traction force (daN)	350	250
Rod stroke (mm)	290	
Rod speed (cm/s)	1,6	
Temperature range (°C)	-20 ÷ +55 °C	
Operator weight (Kg)	6,5	
Housing protection	IP 44	
Duty cycle (cycles/hour)	18	50
Maximum leaf length (m)	1,80	

Drawing A

INSTALLATION DIMENSIONS

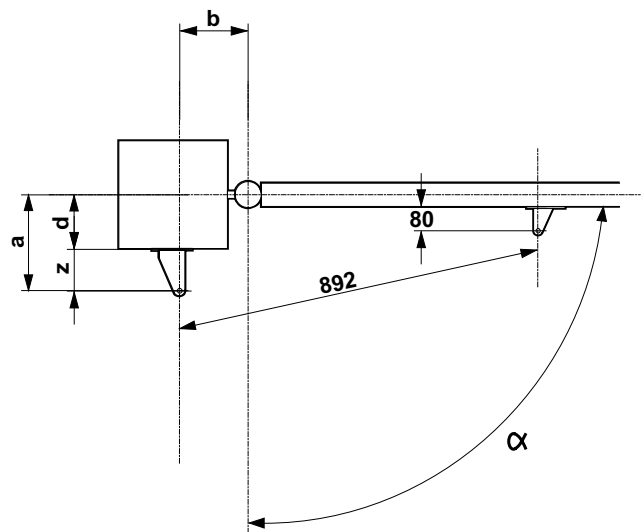

Fig. A

Table A: Recommended dimensions

Opening angle "α"	a (mm)	b (mm)	c (*) (mm)	d (**)(mm)
90°	145	145	290	100
110°	125	125	290	80

(*) working excursion of piston rod (**) maximum dimensions

CALCULATING INSTALLATION DIMENSIONS: GENERAL RULES

If modifications to the dimensions specified in Table A are necessary, proceed as follows:

- For 90° leaf opening: $a + b = c$
- For leaf opening over 90°: $a + b < c$
- **The lower the dimensions of a and b the higher the gate speed.** Always respect current standards.
- **Limit the difference between a and b to within 4 cm:** larger differences alter speed considerably during opening and closing.
- For reasons of operator clearance, **the minimum value for Z is 45 mm** (fig. A)

If the dimensions of the gate post or position of the hinge do not allow for the specified distance of "a", make a recess in the gate post as shown in fig. B.

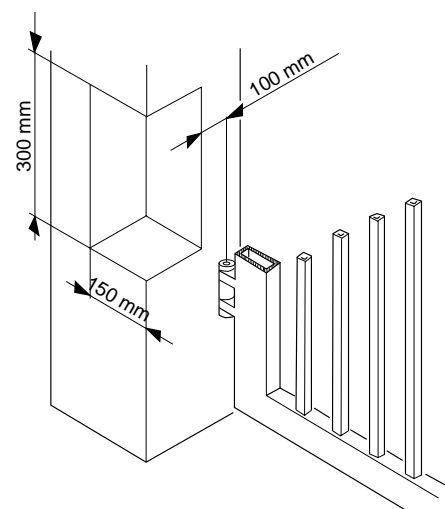

Fig. B

2. STANDARD INSTALLATION LAYOUT

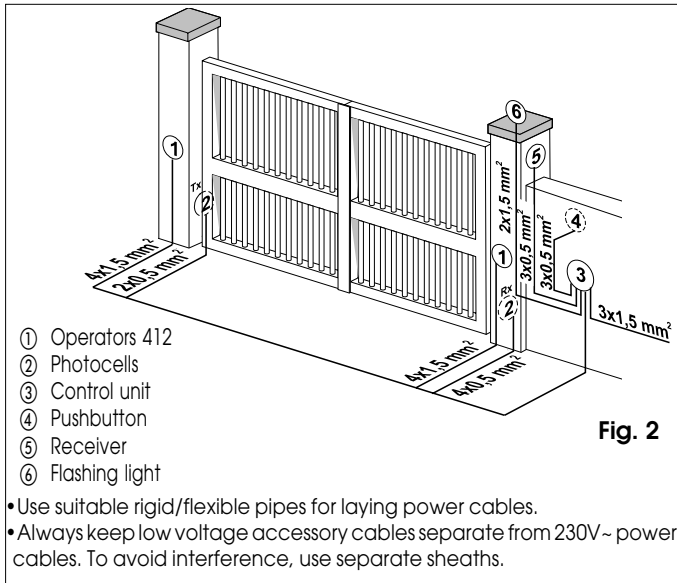

Fig. 2

3. INSTALLATION OF THE AUTOMATION SYSTEM

3.1. PRELIMINARY CHECKS

To ensure trouble-free operation, make sure that the gate (whether existing or yet to be installed) has the following specifications:

- max. length of each gate leaf: 1.8 metres
- strong and rigid leaf frame
- smooth gate movement, with no stiff points
- hinges in good condition
- mechanical travel limit stops

If any welding or brazing has to be done on the gate, do this before installing the automation system. The good order of the structure directly influences the reliability and safety of the automation system.

3.2. INSTALLATION OF THE OPERATORS

- 1) Fix the rear bracket to the gate post according to the instructions in Table A. Adjust the length of the bracket if necessary.

Warning: Observe the specified dimensions to ensure correct operator functioning.

In the case of iron gate posts, weld the bracket directly onto the gate post.

In the case of brick/concrete gate posts, flush-mount a wall plate (fig. 3), and weld the bracket to the plate.

- 2) Fix the operator to the rear bracket by means of the screws supplied (fig. 3).

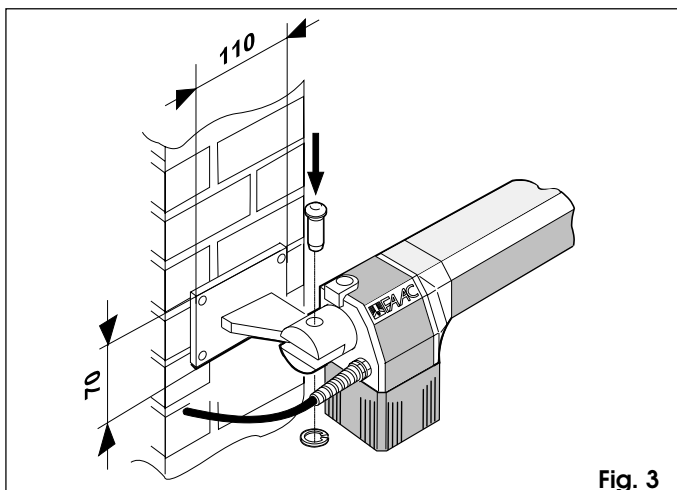

Fig. 3

Caution: the operators supplied in the kit are left and right hand versions.

For correct installation the operator must be positioned as shown in fig. 3.

- 3) Release the operator (see paragraph 5).
- 4) Extend the rod to the end of its stroke (fig. 4).
- 5) Lock the operator (see paragraph 6).
- 6) Rotate the operator rod two full turns clockwise (fig. 4).
- 7) Fit the front bracket onto the rod as shown in fig. 5.
- 8) Close the gate leaf and, keeping the operator perfectly horizontal, locate the leaf attachment position of the front bracket (fig. 6).
- 9) Fix the front bracket temporarily to the leaf by two welds.

N.B.: If the gate frame does not allow for secure fixing of the bracket, add a support plate.

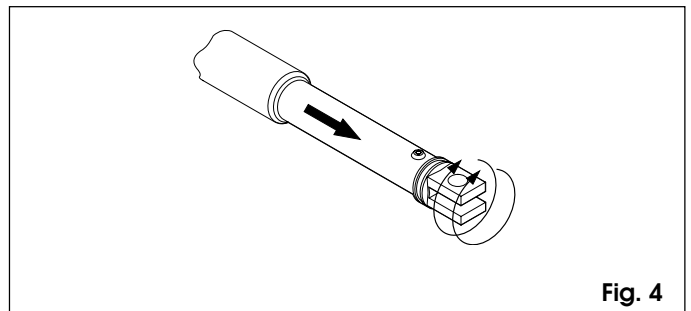

Fig. 4

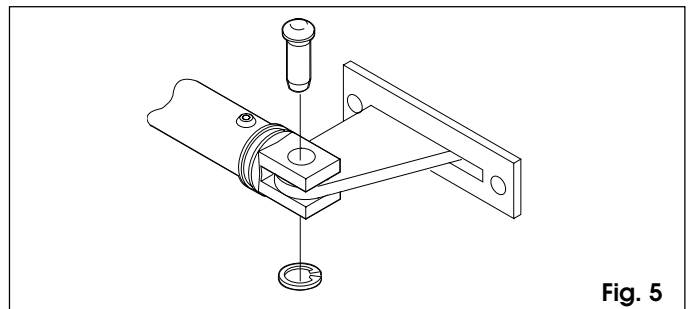

Fig. 5

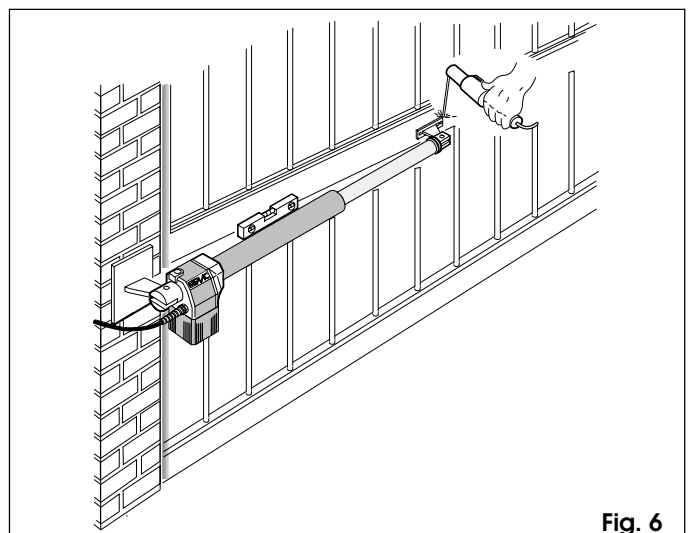

Fig. 6

- 10) Release the operator and ensure that the gate opens smoothly with no stiff points and that it stops on the mechanical travel stops.
- 11) Completely weld the front bracket to the leaf. To weld, detach the operator temporarily from the bracket to prevent any waste material from damaging it.

- N.B.:** 1) Grease all pivots on brackets
 2) If welding is not possible, the front and rear bracket plates are also designed for fixing by screws and screw anchors.

12) Fit the cover (fig. 7) on the operator as shown in fig. 8.

N.B.: Fix the guide support of the cover on the hole furthest from the cap (fig.7).

- 13) Repeat the above operations to install the second operator.
 14) Make the control unit connections.
 15) Programme the control unit to set the specific installation requirements.

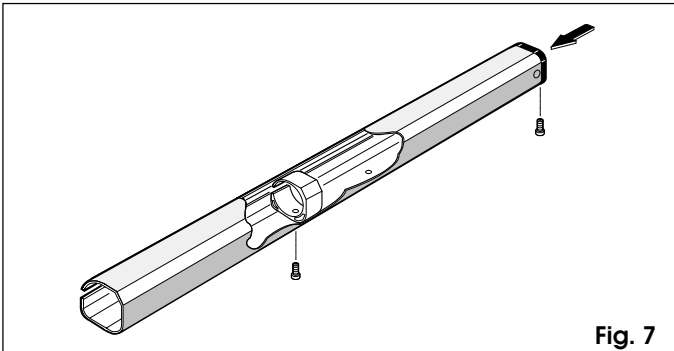

Fig. 7

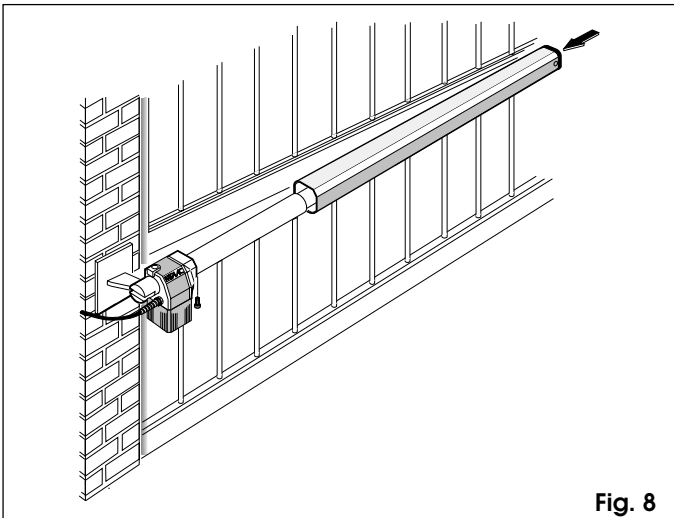

Fig. 8

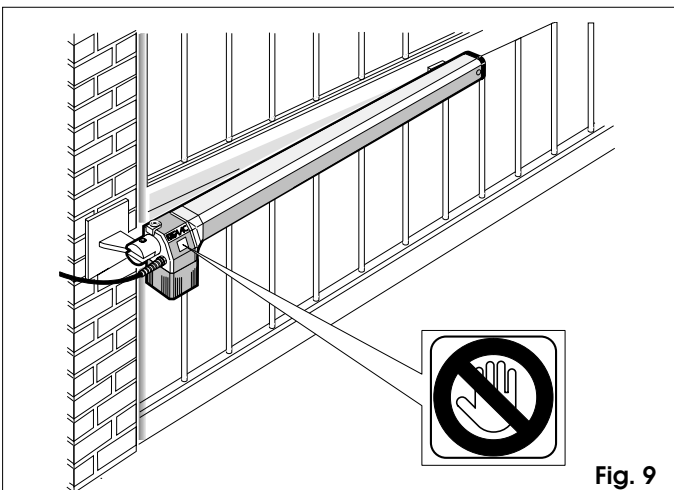

Fig. 9

4. TESTING THE AUTOMATED UNIT

On completing installation, affix a danger warning adhesive label in a clearly visible position on the side of the operator (fig. 9).

Careful check operation of the operator and all accessories connected to it.

Give the customer the "User guide" and demonstrate how to use the operator correctly. Point out the potential danger zones of the automated unit.

5. MANUAL OPERATION

In the event of a power failure or malfunction, the gate can be operated manually by removing the plug and inserting the special release key as shown in fig. 10.

To release the operator, turn the key in the direction of leaf closing (fig. 10).

Open or close the leaves manually.

6. RETURNING TO NORMAL OPERATION

Turn off the electricity supply to the system before re-locking the operators to avoid all risk of starting them accidentally.

To re-lock the operator, turn the key in the leaf opening direction (fig. 10).

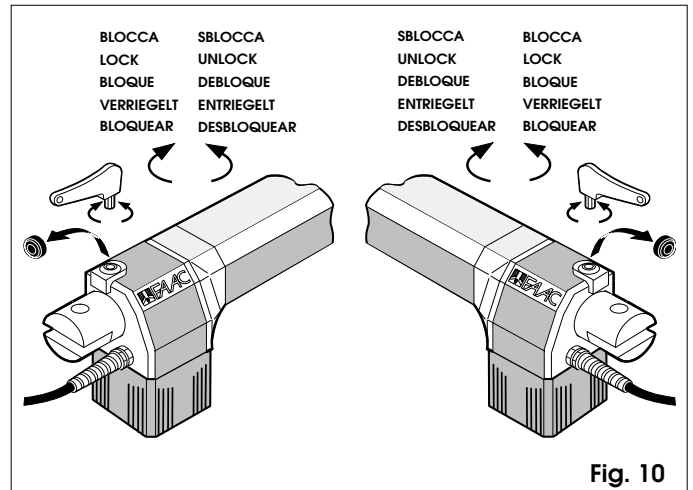

Fig. 10

7. SPECIAL APPLICATIONS

There are no special applications.

8. MAINTENANCE

Carry out periodic checks of the gate structure and ensure in particular that the hinges are in perfect working condition.

Check periodically that the electronic anti-crushing system is adjusted correctly and that the release mechanism for manual movement is fully operative (see relative paragraph).

Safety devices installed on the plant must be checked every six months.

9. REPAIRS

For repairs, refer to authorised FAAC service centres.

412

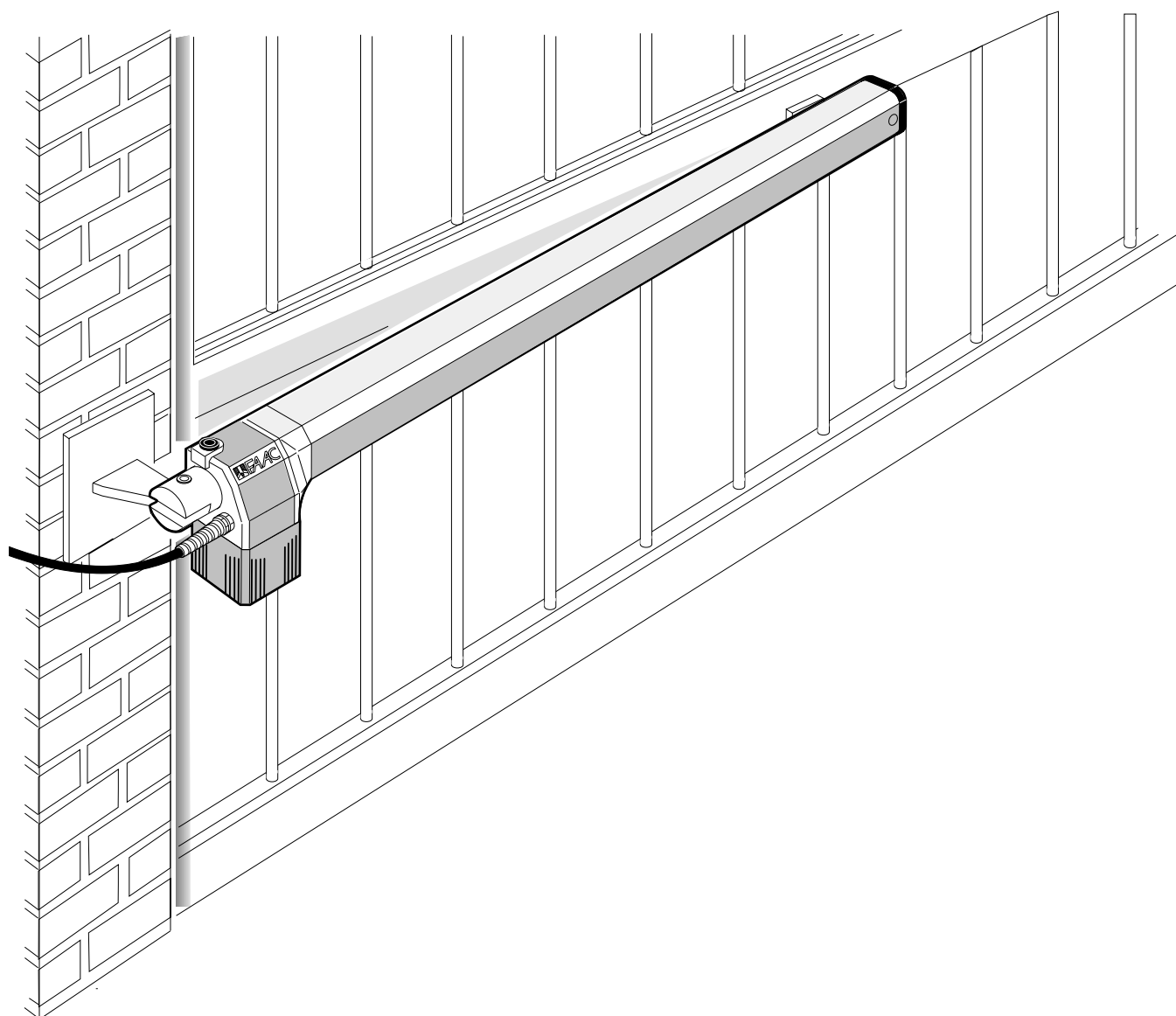

FAAC

END-USER GUIDE

412 Automation Systems

Read the end user guide carefully before using the product and keep it in a safe place for future reference.

GENERAL SAFETY REGULATIONS

When correctly installed and used, the 412 automation system ensures a high degree of safety. A few simple rules should be followed to prevent accidental problems.

- Do not pass between the leaves when they are still moving; always wait until they have opened completely.
- Do not linger between the leaves.
- Do not linger near the automation system; do not allow children or adults to linger near it; and do not leave objects near it.
- Keep wireless control devices, or other devices that might accidentally activate the automation system, out of the reach of children.
- Do not allow children to play with the automation system.
- Do not impede the movement of the leaves.
- Do not allow branches or bushes to interfere with the movement of the leaves.
- Ensure that the warning lamps are always in working order and visible.
- Do not attempt to actuate the leaves manually unless you have first unlocked them.
- In case of a malfunction, unlock the leaves to allow vehicles to pass, and call a qualified technician.
- If you have set the manual mode, before restoring normal operation, disconnect the power supply.
- Do not modify the components of the automation system.
- Do not attempt to repair the automation system or to perform any operation on it. Call qualified technicians only.
- At least once every 6 months, have qualified personnel check that the automation system, safety devices and earth connection are in working order.

DESCRIPTION

The FAAC 412 automation consists of two electromechanical operators which are ideal for controlling swinging gates with each leaf up to 1.80 m long.

The two electromechanical operators transmit movement to the leaves by a worm screw system.

The operators are controlled by an electronic control unit, mounted in an enclosure which assures adequate protection against atmospheric agents.

The leaves are normally closed. When the electronic control unit receives an open command from the remote radio control or any other control device, it activates the electromechanical system and causes the leaves to rotate by an angle of up to 110° to their open position, so as to allow access.

If automatic operation has been selected, the leaves close automatically after the selected pause time.

If semiautomatic operation has been selected, a second impulse must be sent to close the leaves.

An open command given while the leaves are closing causes the leaves to reverse direction of movement.

A stop command (if available) stops movement at any time.

For detailed information on the operation of the automation system in the various operating modes, contact the installation technician.

The automation system is equipped with a photocell safety device which prevents the leaves from closing when the photocells are darkened by an obstacle.

The 412 automation system is also equipped with an anti-crushing safety device (fitted as standard) that limits the torque transmitted to the leaves.

The operators ensure that the system is mechanically locked when the motor is not running, so there is no need to install a lock.

The leaves can be opened manually only by operating the unlocking device.

The lamp flashes while the leaves are moving.

MANUAL OPERATION

If the gate has to be operated manually due to a malfunction or power supply failure, remove the safety cap and insert the key provided into the release system as shown in fig. 1. To release the operator, turn the key in the leaf closure direction (fig. 1).

Open or close the leaf manually.

RETURNING TO NORMAL OPERATION

To prevent an accidental impulse from activating the operators during this operation, disconnect the system from the power supply before re-locking the operators.

To re-lock the operator, turn the key in the leaf opening direction (fig. 1).

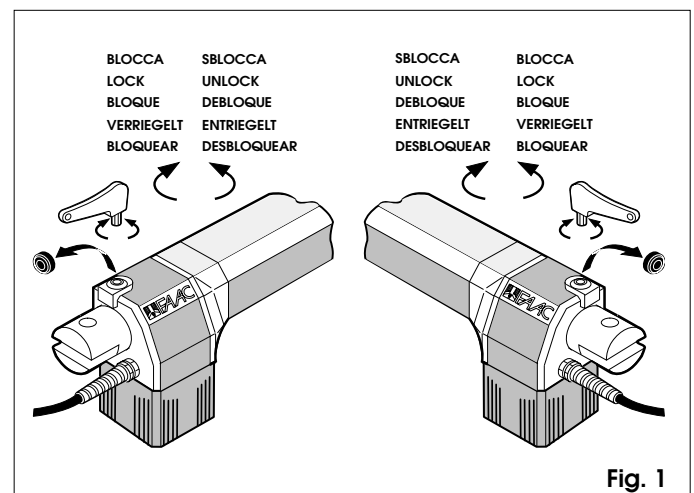

Fig. 1

Le descrizioni e le illustrazioni del presente manuale non sono impegnative. La FAAC si riserva il diritto, lasciando inalterate le caratteristiche essenziali dell'apparecchiatura, di apportare in qualunque momento e senza impegnarsi ad aggiornare la presente pubblicazione, le modifiche che essa ritiene convenienti per miglioramenti tecnici o per qualsiasi altra esigenza di carattere costruttivo o commerciale.

The descriptions and illustrations contained in the present manual are not binding. FAAC reserves the right, whilst leaving the main features of the equipments unaltered, to undertake any modifications it holds necessary for either technical or commercial reasons, at any time and without revising the present publication.

Les descriptions et les illustrations du présent manuel sont fournies à titre indicatif. FAAC se réserve le droit d'apporter à tout moment les modifications qu'elle jugera utiles sur ce produit tout en conservant les caractéristiques essentielles, sans devoir pour autant mettre à jour cette publication.

Die Beschreibungen und Abbildungen in vorliegendem Handbuch sind unverbindlich. FAAC behält sich das Recht vor, ohne die wesentlichen Eigenschaften dieses Gerätes zu verändern und ohne Verbindlichkeiten in Bezug auf die Neufassung der vorliegenden Anleitungen, technisch bzw. konstruktiv/kommerziell bedingte Verbesserungen vorzunehmen.

Las descripciones y las ilustraciones de este manual no comportan compromiso alguno. FAAC se reserva el derecho, dejando inmutadas las características esenciales de los aparatos, de aportar, en cualquier momento y sin comprometerse a poner al día la presente publicación, todas las modificaciones que considere oportunas para el perfeccionamiento técnico o para cualquier otro tipo de exigencia de carácter constructivo o comercial.

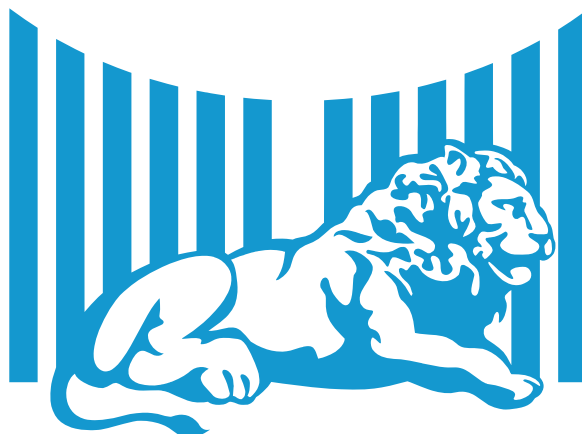

FAAC

FAAC S.p.A.
Via Benini, 1
40069 Zola Predosa (BO) - ITALIA
Tel. 0039.051.61724 - Fax. 0039.051.758518
www.faac.it
www.faacgroup.com

