

WARNING

This quick guide is a summary of the complete installation manual. The manual contains safety warnings and other explanations which must be taken into account. The installation manual can be downloaded by going to the "Downloads" section of Erreka website:
<http://www.erreka.com/Automatismos/descargaDocumentos.aspx>

Elements of the complete installation

NOTE: this control board is valid for gate operators:
 swing (E 30 I),
 sliding (E 302),
 up-and-over (E 303).

Electrical wiring

- A: Main power supply
- B/F: Flashing light with antenna
- C: Photocells (Rx / Tx)
- D: Key switch
- E: Operator

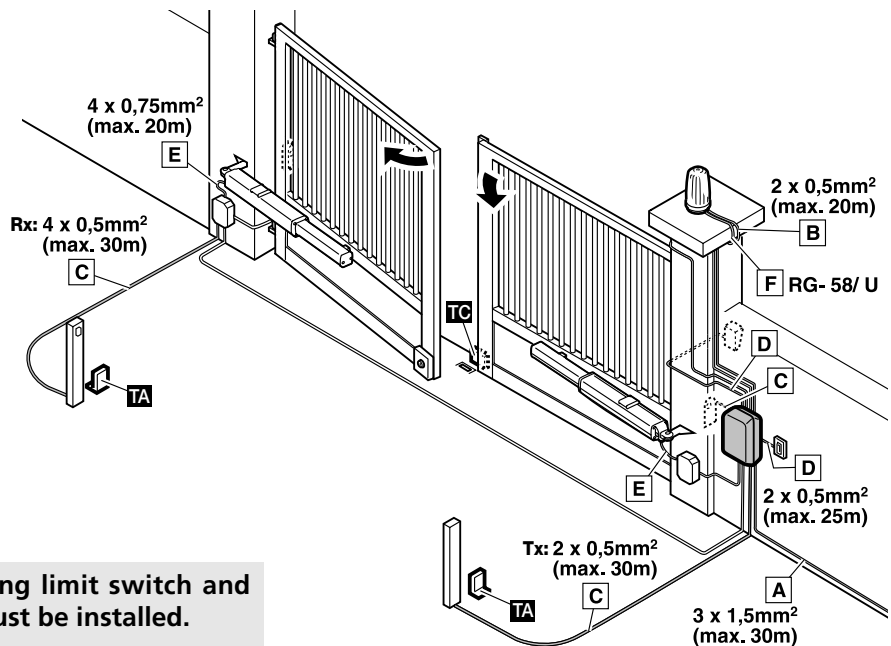

VERY IMPORTANT: The **TC** closing limit switch and the **TA** opening limit switches must be installed.

E241B

Power supply and peripheral cabling (valid for all cases)

EPS1: traffic light card (with parameter Rb00) or brake card (with parameter Rb0 I, see connection diagram on page 12). See other options on page 16.

ST1: open
 ST2: close

- DL6: LED FT1
- DL9: LED FT2
- DL10: LED ST2
- DL11: LED ST1
- DL12: LED radio running
- DL13: LED garage light
- DL14: LED 12Vdc
- DL15: LED lock

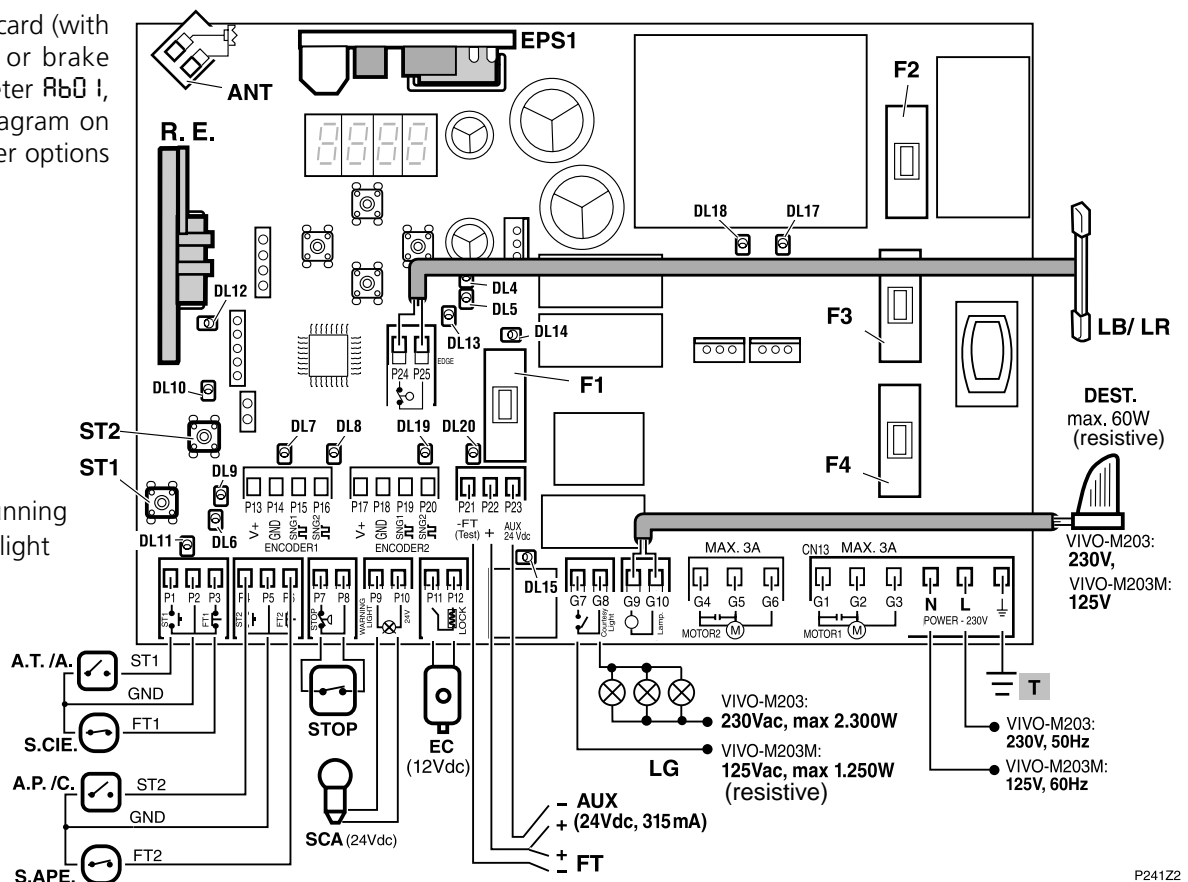

P241Z2

Operator cabling for swing gates with single or dual leaf (parameter $\text{C } 30 \text{ I}$)

DL4: LED relay M1
DL5: LED relay M2
DL17: LED triac M1
DL18: LED triac M2

ST1: open
ST2: close

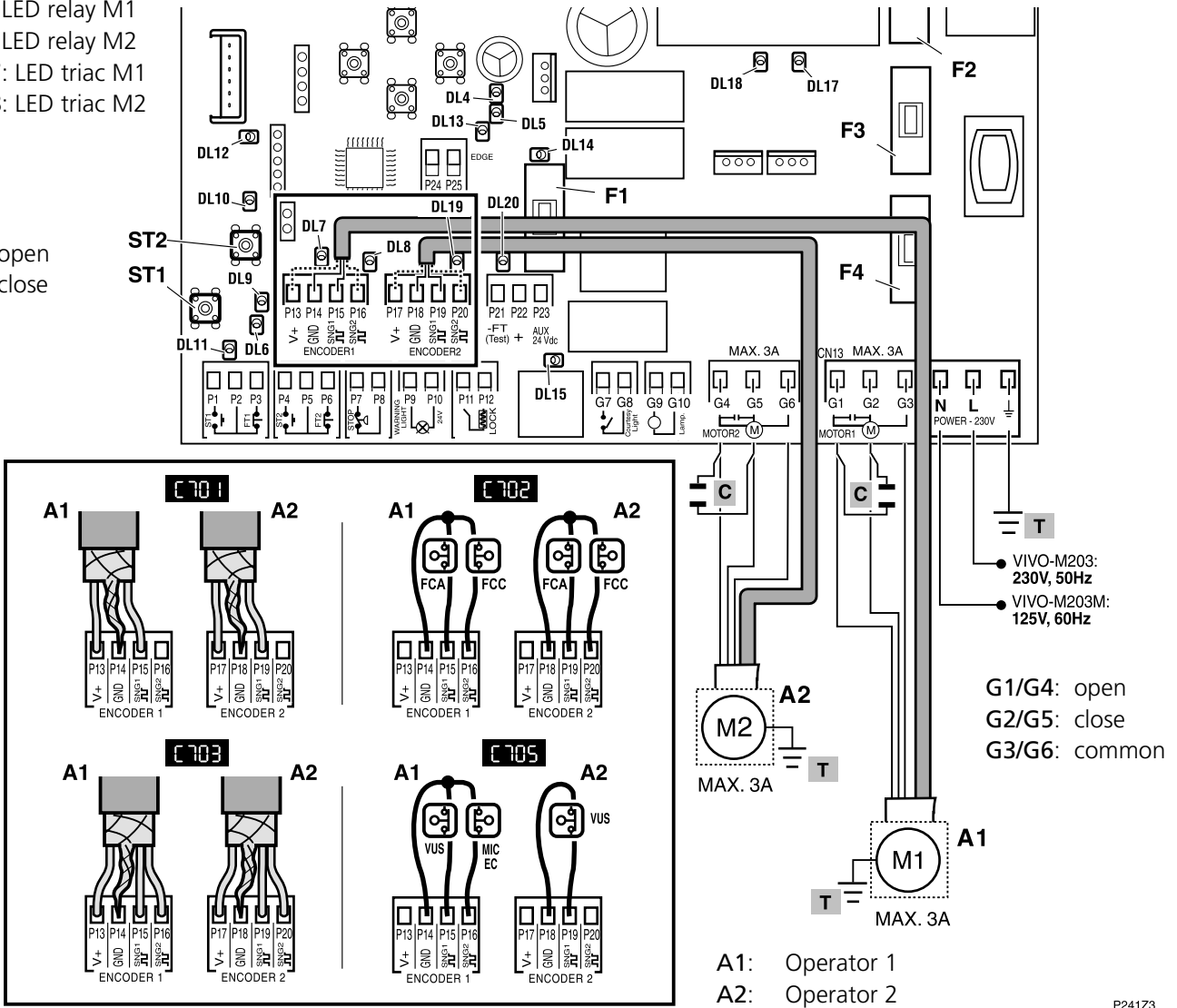

DL7: LED SNG1 (FCA/encoder) A1
DL8: LED SNG2 (FCC/encoder) A1
DL19: LED SNG1 (FCA/encoder) A2
DL20: LED SNG2 (FCC/encoder) A2

☞ The colour of the G1/G4 and G2/G5 cables must be respected in order to correctly programme the turning directions, i.e., the colour of G1 must be the same as for G4 (and G2 the same as G5).

Single encoder connection ($\text{C } 70 \text{ I}$)

V+: red cable
GND: mesh
SGN1: green or blue cable
SGN2: do not connect

Limit switch connection ($\text{C } 70 \text{ 2}$)

V+: do not connect
GND: common (COM)
SGN1: opening (FCA)
SGN2: closing (FCC)

Dual encoder connection ($\text{C } 70 \text{ 3}$)

V+: red cable
GND: mesh
SGN1: green or blue cable
SGN2: white cable

Vulcan connection VUS ($\text{C } 70 \text{ 5}$)

V+: do not connect
GND: common (COM)
SGN1: VUS operator safety micro
SGN2: electrolock micro (A1 connector only)

☞ The $\text{C } 70 \text{ 4}$ option is not available for swing gate operators. if $\text{C } 70 \text{ 4}$ is selected, it will operate as $\text{C } 70 \text{ I}$.

P24123

Operator cabling for sliding and up-and-over doors (parameters [302 and [303)

- DL7: LED SNG1 (encoder) E1
- DL8: LED SNG2 (encoder) E1
- DL19: LED SNG1 (FCA/ATS) E2
- DL20: LED SNG2 (FCC/NA) E2

ST1: open
ST2: close

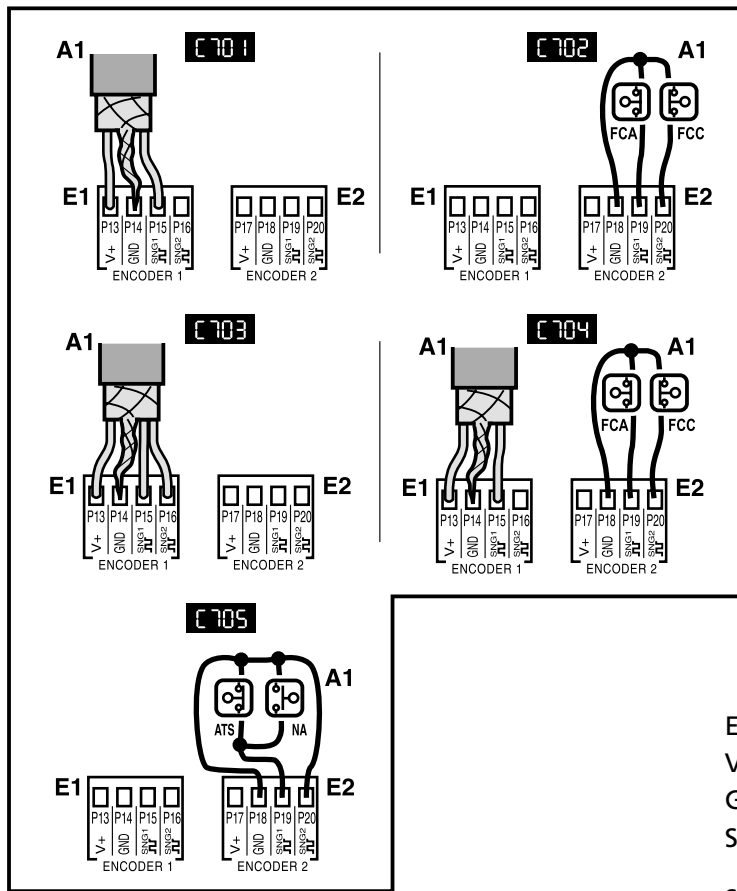
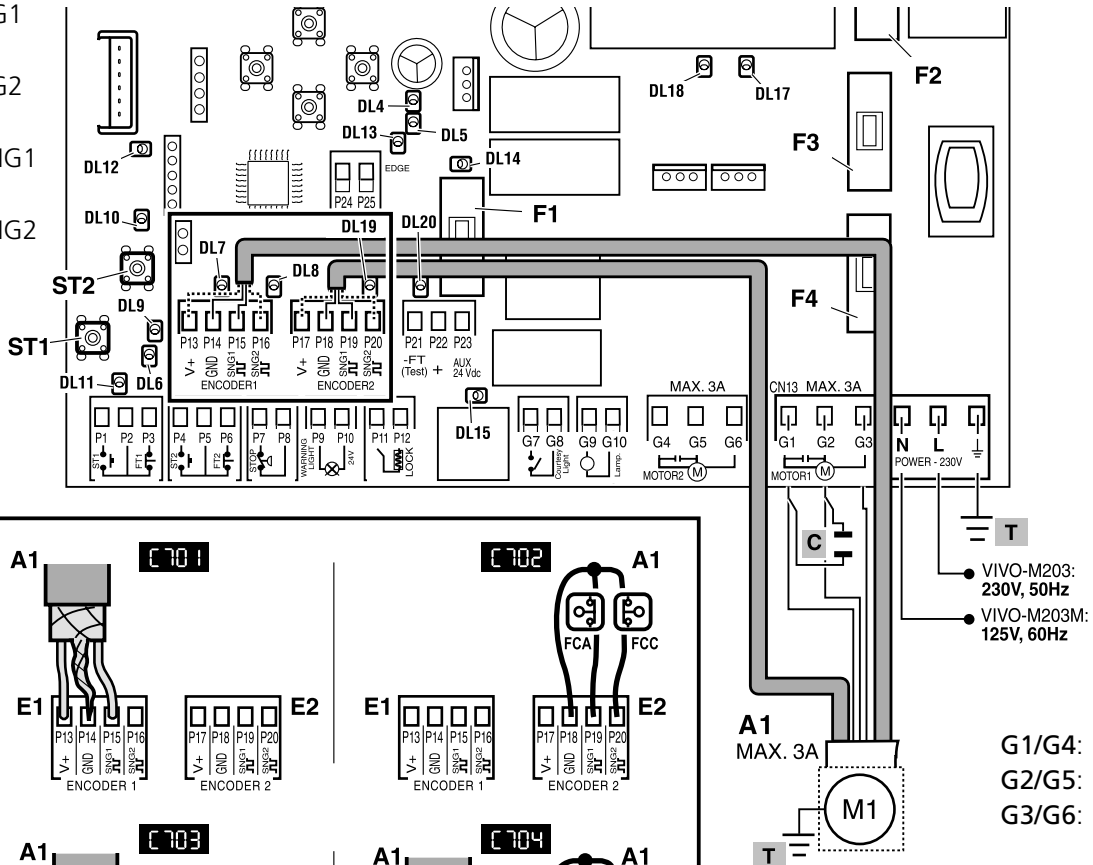

A1 MAX. 3A
M1
G1/G4: open
G2/G5: close
G3/G6: common

- DL4: LED relay M1
- DL5: LED relay M2
- DL17: LED triac M1
- DL18: LED triac M2

A1: Operator 1
E1: "ENCODER 1" terminals
E2: "ENCODER 2" terminals

ATLAS connection (ATS) G6xx1 ([705)

E2 connector:

- V+: do not connect
- GND: common (COM)
- SGN1: ATS operator safety micro and NA closing micro (parallel connection)
- SGN2: bridge to GND

Single encoder connection ([701)

- E1 connector:
- V+: red cable
 - GND: white cable
 - SGN1: green or blue cable
 - SGN2: do not connect

Limit switch connection ([702)

- E2 connector:
- V+: do not connect
 - GND: common (COM)
 - SGN1: opening (FCA)
 - SGN2: closing (FCC)

Dual encoder connection ([703)

- E1 connector:
- V+: red cable
 - GND: white cable
 - SGN1: green or blue cable
 - SGN2: purple cable

FC and single encoder connection ([704)

- E1 connector:
- V+: red cable
 - GND: white cable
 - SGN1: green or blue cable
 - SGN2: do not connect
- E2 connector:
- V+: do not connect
 - GND: common (COM)
 - SGN1: opening (FCA)
 - SGN2: closing (FCC)

☛ In sliding ([302) and up-and-over doors ([303), it is only possible to use a single motor (M1), which should be connected to the "MOTOR 1" terminals.
When using a single encoder ([701, [704) or dual encoder ([703), always connect to the "ENCODER 1" terminals.
When using limit switches ([702, [704 or [705), always connect to the "ENCODER 2" terminals.

Brake cabling

☞ If the operator has a brake connected internally to the motor (e.g. ORION operators), the brakes do not need to be connected, although slowdown should be cancelled (select $\text{C}300$).

☞ If the operator has a brake to connect independently (for example, CICLON or MAGIC operators), use the EPS1 card as shown in the diagram and select the parameter $\text{Ab}01$.

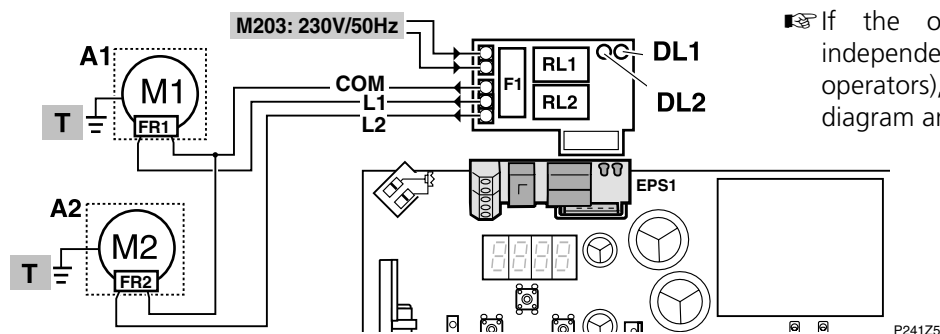

DL1: Red LED, FR1 activation
DL2: Green LED, FR2 activation

Display indications

☞ The display shows a horizontal segment in D4 whenever no key is pressed for 15 minutes. This will light up when any of the ESC, ENTER, UP, DOWN pushbuttons are pressed.

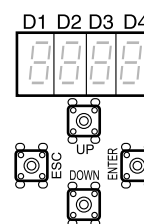

D1 and D2 (gate status):

CL (static)	Gate closed
CL (flashing)	Gate closing
OP (static)	Gate open
OP (flashing)	Gate opening
PC (flashing)	Pedestrian gate closing
PO (static)	Pedestrian gate open
PO (flashing)	Pedestrian gate opening
XX (countdown)	Gate on standby
PR (static)	Pause (operation not complete)
rS (static)	Gate resetting (searching for opening or closing position)

D3 and D4 (error messages):

$\text{C}4$	Opening safety device activated
$\text{C}5$	Closing safety device activated
$\text{C}9$	Mechanical or resistive strip activated
$\text{E}1$	Motor 1 encoder failure
$\text{E}2$	Motor 2 encoder failure
$\text{F}1$	Motor 1 force limit exceeded
$\text{F}2$	Motor 2 force limit exceeded

HP (static) Dead-man mode

StOP Operator unlocked

☞ In swing gates, $\text{C}4$ refers to the interior photocell and $\text{C}5$ refers to the exterior one (instead of opening and closing, respectively).

Gate type selection ($\text{C}3$)

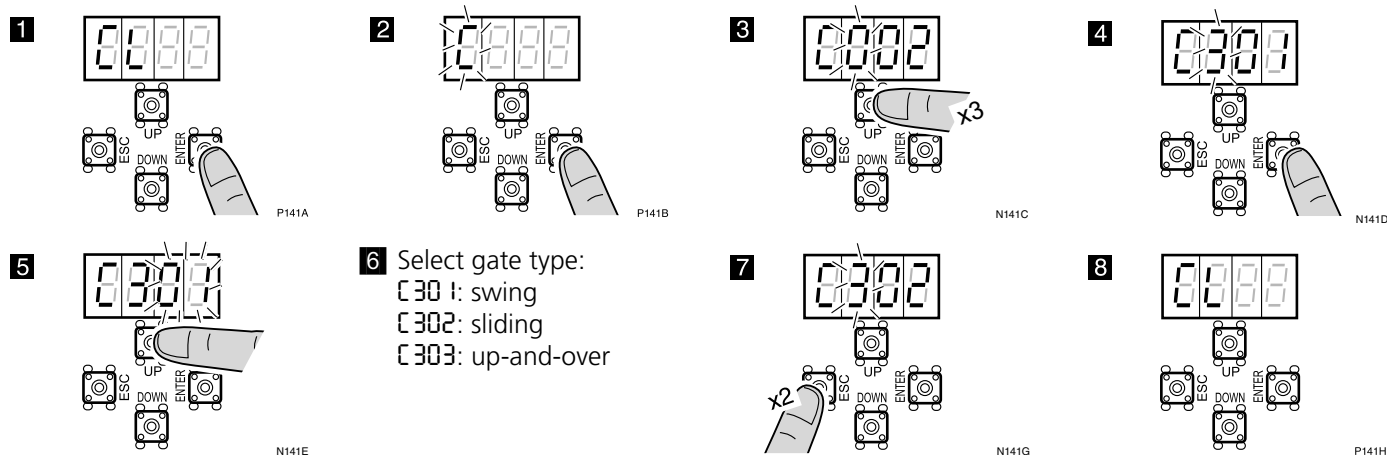

Number of operators selection (C0); in swing gates only (C30 I)

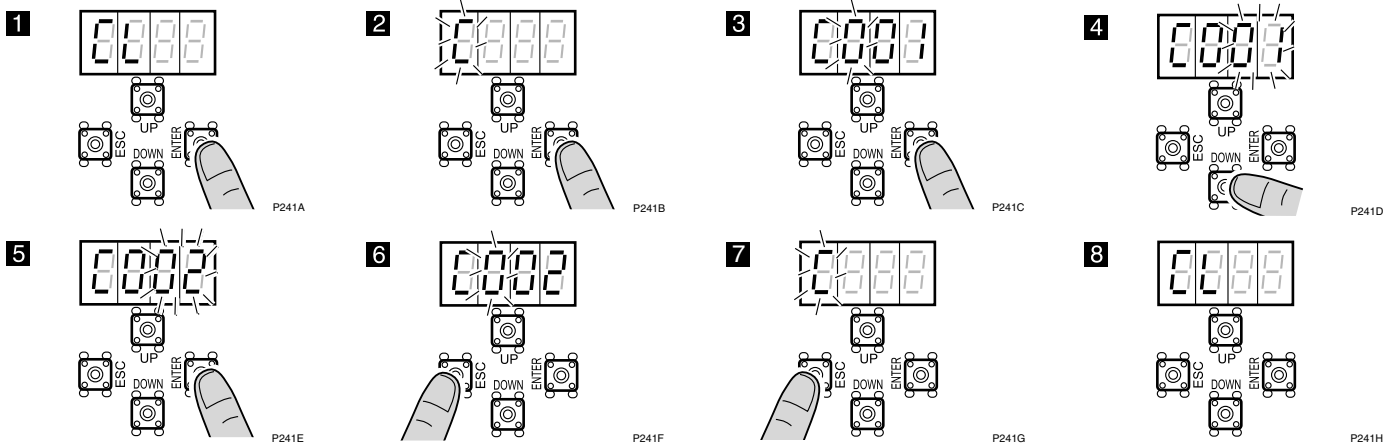

Changing and checking turning direction for operator A1 and A2 (C I)

- ☞ This operation is only necessary if operator A1-A2 closes the leaf instead of opening it when resetting (r-5).
- ☞ In step **4**, check turning direction using ST1 (open) and ST2 (close). Use C I to activate operator 1 and C 2 to activate operator 2.

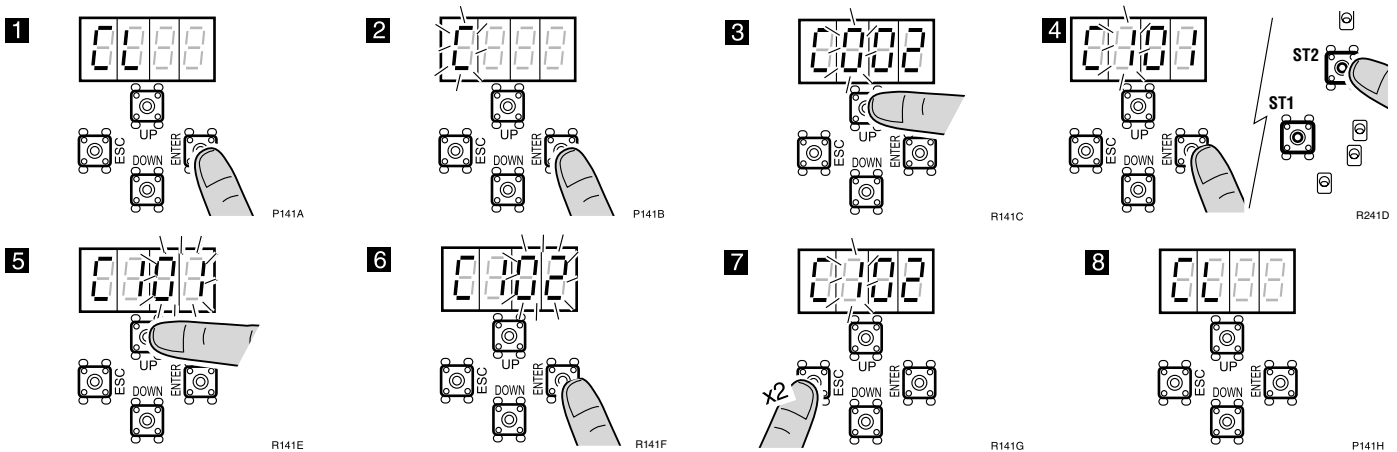

Changing and checking turning direction for operator A1 and A2 (C 2)

- ☞ A1 and A2 work simultaneously, both C I and C 2 change the turning direction of the two operators at the same time. The turning direction of a single operator cannot be changed.

P I Total opening radio code programming (with RSD receiver only, C80 I)

- ☞ If a receiver other than RSD is used, see the corresponding instructions.
- ☞ Before starting programming, select the option C80 I (RSD receiver).

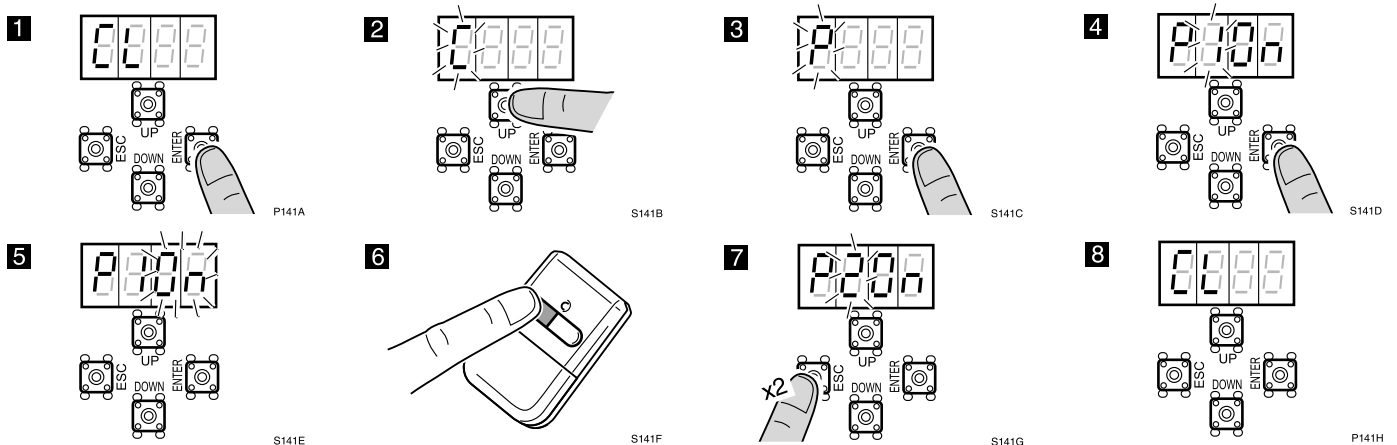

P2 Pedestrian opening radio code programming (with RSD receiver only)

- ☞ This procedure is the same as for total opening, but using parameter P2 P I.

Programming travel (all cases)

▲ The opening and closing limit switch must be installed before programming the travel (see the operator manual).

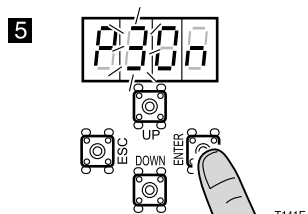
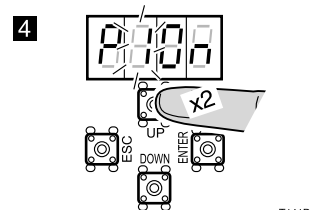
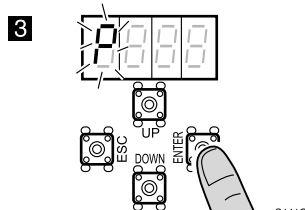
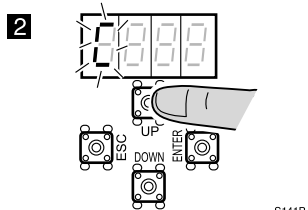
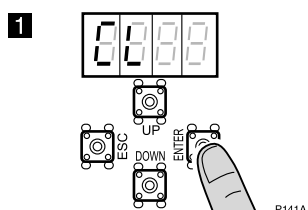

6 With encoder and/or obstacle detection without slowdown, the gate carries out the approach operation (opens for 4 seconds and then closes to programme the closing point). It also carries out soft stop in accordance with the ϵR value. In other cases, close the gate before starting programming.

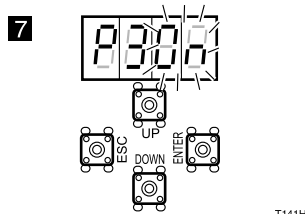

The procedure with a swing gate is shown below. Proceed in a similar manner for sliding gates and up-and-over doors.

8 Start opening of leaf 1 with ST1:

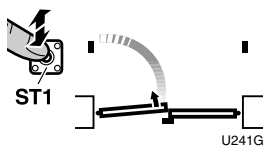

9 Start slowdown of leaf 1 with ST1 (only with $\epsilon R01$ or $\epsilon R02$):

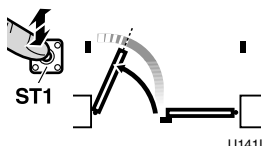

10 Finish opening of leaf 1 with ST1:

In any case, this is carried out automatically when the opening limit switch is reached (with $\epsilon 701$, $\epsilon 703$, $\epsilon 704$ or $\epsilon 705$) or the FCA (with $\epsilon 702$ or $\epsilon 704$).

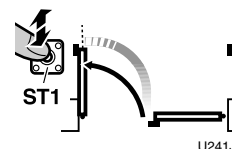

11 Start opening of leaf 2 with ST1:

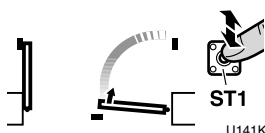

12 Start slowdown of leaf 2 with ST1 (only with $\epsilon R01$ or $\epsilon R02$):

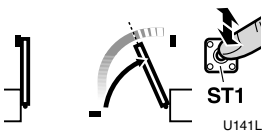

13 Finish opening of leaf 2 with ST1:

In any case, this is carried out automatically when the opening limit switch (with $\epsilon 701$, $\epsilon 703$, $\epsilon 704$ or $\epsilon 705$) or the FCA (with $\epsilon 702$ or $\epsilon 704$) is reached.

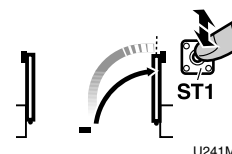

14 Start closing of leaf 2 with ST1:

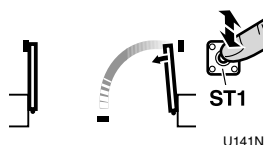

15 Start slowdown of leaf 2 with ST1 (only with $\epsilon R01$ or $\epsilon R03$):

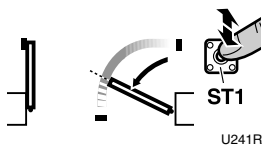

16 Finish closing of leaf 2 with ST1:

In any case, this is carried out automatically when the closing limit switch (with $\epsilon 701$, $\epsilon 703$ or $\epsilon 704$) or the FCC (with $\epsilon 702$, $\epsilon 704$ or $\epsilon 705$) is reached.

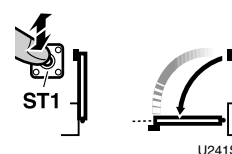

17 Start closing of leaf 1 with ST1:

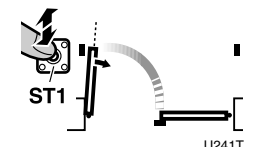

18 Start slowdown of leaf 1 with ST1 (only with $\epsilon R01$ or $\epsilon R03$):

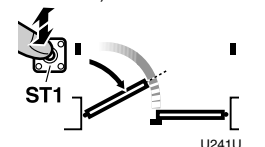

19 Finish closing of leaf 1 with ST1:

In any case, this is carried out automatically when the closing limit switch (with $\epsilon 701$, $\epsilon 703$ or $\epsilon 704$) or the FCC (with $\epsilon 702$, $\epsilon 704$ or $\epsilon 705$) is reached.

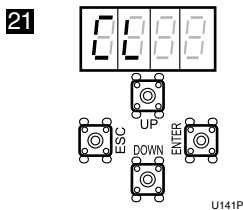
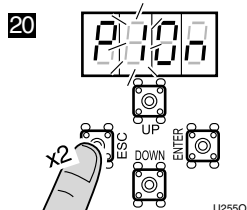
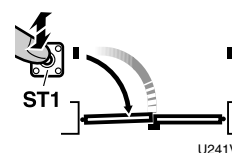

The anti-trapping safety system continues to run during programming operations.

Pedestrian opening is programmed using F3, meaning it is not necessary to record this pedestrian opening travel.

Whenever an obstacle is detected during programming in up-and-over operation with the $\epsilon 5$ closing photocell activated, this will be taken as the point from where to activate the photocell shadow area. Only works with Collective Opening ($\epsilon R01$).

Complete programming chart (I)

D1	D2	Parameter	D3	D4	Default option	Options or values
C	0	Number of operators	0	1, 2	0 1	0 1: one operator, 02: two operators (only available with C 30 1)
	1	Operator 1 turning direction (operator 2 also changes)	0	1, 2	0 1	0 1: direction A, 02: direction B. Check direction by pressing ST1 (open) and ST2 (close)
	2	Operator 2 turning direction (operator 1 also changes)	0	1, 2	0 1	0 1: direction A, 02: direction B. Check direction by pressing ST1 (open) and ST2 (close)
	3	Gate type	0	1... 3	0 1	0 1: swing, 02: sliding, 03: up-and-over
	4	Opening safety device (photocell)	0, 1	0, 1	00	00: not installed, 10: no testing, 1 1: with testing
	5	Closing safety device (photocell) Closing photocell with C 520 or C 52 1, also prevents gate opening from starting	0...2	0, 1	00	00: not installed, 10: no testing, 1 1: with testing 20: no testing, 2 1: with testing
	6	Electrolock / electromagnet C 630 and C 640 are used to manage an external relay at 24Vdc, connected to cable connectors P11-P12. The electromagnet must be externally supplied (through this relay) and sized in line with the electromagnets used.	0...4	0...4	00	00: not installed 1X: electrolock without reverse impulse. Programmable electrolock time: 3 seconds with X=0 (by default), 3.5s with X=1, 4s with X=2, 4.5s with X=3, 5s with X=4. 2X: electrolock with reverse impulse. Programmable time (electrolock/motor reverse): 4.5/1.5 seconds with X=0 (by default), 5/2s with X=1, 5.5/2.5s with X=2, 6/3s with X=3, 6.5/5s with X=4. 30: electromagnet without impulse 40: drop electromagnet
	7	Encoder / Limit switches The cabling depends on the type of operator selected (C 30 1, C 302 or C 303); see the corresponding wiring diagram)	0	0...5	00	00: not installed; 0 1: with single encoder; 02: with limit switches; 03: with dual encoder; 04: with encoder and limit switches (not available with C 30 1 selected); 05: VULCAN VUS and ATLAS (ATS) G6xxl (only available with C 30 1 or C 303 selected)
	8	Radio card	0	1, 2	02	0 1: RSD card (no decoder); 02: two channel decoder card
	9	Safety strip	0	1, 2	0 1	0 1: mechanical; 02: resistive 8k2
A	Slowdown	0	0...3	02	00: no slowdown; 0 1: slowdown in opening and closing; 02: slowdown in opening; 03: slowdown in closing	
P	1	Total opening radio programming	o	n		Programmes total opening channel and code
	2	Pedestrian opening radio programming	o	n		Programmes pedestrian opening channel and code
	3	Programming gate travel	o	n		Programmes the operations in accordance with the configuration C A
F	1	Key command by way of ST1 and ST2 pushbuttons. With F 10 1 the gate (total or pedestrian) can be kept open by keeping ST1 or ST2 pressed down respectively. This allows the time scheduler to be used in combination with F 2 and/or F 4 ≠ 00.	0	0...4	0 1	00: ST1 and ST2 without effect, the key commands are given by radio (channel 1: total opening-closing, channel 2: pedestrian opening-closing) 0 1: ST1 total opening-closing, ST2 pedestrian opening-closing 02: ST1 total opening, ST2 total closing 03: dead-man mode (the display shows HP.); 04: dead-man mode in closing
	2	Automatic or step-by-step operation mode and standby time (in seconds) in automatic mode	0..5.	0...9	00	00: step-by-step mode 0 1: automatic mode and standby time 1 second; ... 59: automatic mode and standby time 59 sec.; 1.0: 1 min. 0 sec.; ...; maximum 4 minutes
	3	Pedestrian opening (%)	0...9	0...9	40	00: pedestrian opening is not carried out, 10: 10% of total opening, etc
	4	Pedestrian closing mode	0...5	0...9	00	00: semi-automatic mode 0 1: automatic mode and stand-by time 1 second; ... 59: automatic mode and stand-by time 59 sec.; 1.0: 1 min. 0 sec.; ...; maximum 4 minutes

Complete programming chart (and II)

D1	D2	Parameter	D3	D4	Default option	Options or values
R	0	Flashing light	0	1, 2	01	01: output with voltage, with no pre-warning 02: output with voltage, with pre-warning
	1	Garage light time	0..5	0..9	03	03 = 3 sec.; 59 = 59 sec.; 2.5 = 2 min. 50 sec.; ...; maximum 4 minutes
	2	Torque/nominal force	0	1..9	09	01: minimum, ..., 09: maximum
	3	Regulation of torque/force and slowdown speed	0	1..9	09	01: minimum, ..., 09: maximum
	5	Recede after closing (ensures the operator does not become seized on the stopper)	0	0..5	00	00: no recede; ...; 05: maximum recede
	6	Torque/maximum trapping force (level of increase relative to nominal) The D3 digit allows the level to be adjusted during opening; The D4 digit allows the level to be adjusted during closing	0..9	0..9	00	00: disabled in opening and closing; 01: disabled in opening and level 1 in closing; 10: level 1 in opening and disabled in closing; ...; 65: level 6 in opening and level 5 in closing; ...; 99: level 9 in opening and closing
	7	(Opening or closing) photocell used during standby (in automatic mode only)	0	0..2	02	00: does not affect standby time 01: immediate close when the photocells are released 02: restarts standby time
	8	Effect of the ST1-ST2 pushbuttons during standby (in automatic mode only)	0	0..2	02	00: has no effect during standby 01: brings about closing after 3 seconds 02: restart standby time
	9	Opening mode	0	1..3	02	01: community opening 02: step-by-step alternative shutdown 03: automatic alternative shutdown (if F200 is selected, A903 changes to A902)
	A	Lapse between leaves in opening and closing	0..9	0..9	22	00: no lapse in opening or closing (only apply in gates without overlap); XY: X lapse in opening (X=1: 1 second, ... , X=9: 9 seconds) Y lapse in closing (Y=1: 1 second, ... , Y=9: 9 seconds)
	b	Use of the EPS1 card connector For parameters Ab02 and Ab03, use the EPS1 card and bridge the network input cable connectors instead of connecting them to the network (see "Brake connection" diagram).	0	0..3	00	00: use for standard traffic light; 01: use for brakes 02: NC contact with gate open (L1-COM) and gate closed (L2-COM) 03: impulse 1 second Open (L1-COM) when starting opening and Close (L2-COM) when starting closing. Allows another board to be activated.
	c	Hydraulic pressure maintenance	0	0..6	00	00: no pressure maintenance; 01: every 0.5 hours; 02: every 1 hour; 03: every 2 hours; 04: every 6 hours; 05: every 12 hours; 06: every 24 hours
	d	Ram	0	0, 1	00	00: no ram; 01: with ram
E	Special features	0	0..2	00	00: no special function; 01: opening photocell C4 programmed for pedestrian passage; 02: industrial;	
n	0	Programming lock key Be sure to remember any key used, for future access to the programming	0	0, 1	0000	The preset option is 0000 (no key). If any figure is changed, this is considered a key. Select the required key (starting with D1) using UP and DOWN. Press ESC to cancel or ENTER to confirm and move to D2, and so on.
	1	Total operations completed	X	X		Indicates the hundreds of cycles completed (for example, 68 indicates 6,800 cycles completed)
	2	Partial operations completed	X	X		Indicates the hundreds of cycles completed. This can be reset by pressing ST1, ST2 and ENTER at the same time.
t	0	FTP communication	0	n		Immediate communication with the server
	1	GSM signal intensity	X	X		Indicates signal intensity