



909 Control Panel Instruction For Swing Gates 230VAC

General safety rules

WARNING: Unskilled personnel should never be allowed to assemble, repair or adjust the devices and all necessary precautions must be taken to prevent accidents: power supply disconnected (including backup batteries if present). This product is not suitable for installation in explosive atmospheres.

Keep this handbook carefully, store it attached to the technical installation leaflet in a safe place where it is available to anyone who may need it and make sure that all involved personnel are aware of this.

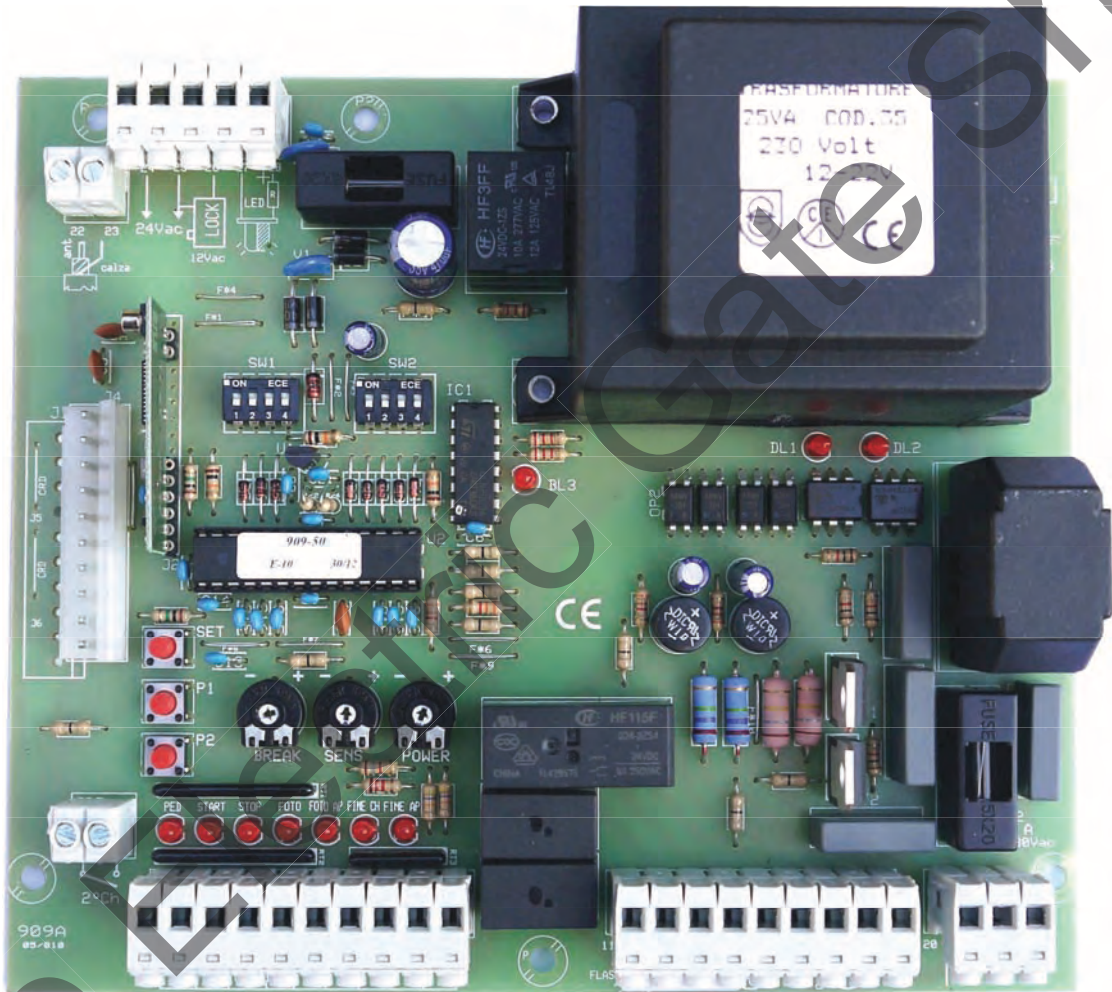

Type of product

The control panel 909 is suitable to control swing gates (1 or 2 operators) with or without electronic clutch. It is auto-programmable and provided with an adjustable anti-crushing feature. It is possible to add a timer to the START input to program openings and closings. It is protected from interferences, lightning and electrostatic events. This control panel has passed all the tests regarding electromagnetic emissions and interferences according to the European standards directive EMC 89/336/CEE, 92/31/CEE, BT 73/23/CEE e 93/68/CEE.

WARNING: the installation and setting of this control panel has to be done only by qualified persons who respect all the actual norms in the field of automatic entrances as well as all the information reported on this manuals. In any case, the installer has to check if it is necessary to install a switch or breaker on the power point before wiring the control panel to the main power supply according to the actual norms. The manufacturer of this control panel can not be responsible for damages or others if the panel is used in a different way to the one explained in this manual. Protect the device with a 6A switch with suitable fuses and earth protection. Use the provided transformer or a similar one. Check that ground wire is connected to the right place. Use individual wires and NOT a multiwires cable. If the distance of the wires is longer than 50 m, then install a relay to control the inputs. All NC inputs must be wired to the input 7 if not used. Minimum diameter is 2,5mm for the wires connecting light and motor. To avoid any interference keep wires for the inputs separated from those for the outputs.

Contents

Page

- 3) DESCRIPTION OF THE MAIN COMPONENTS. Obstacle detection system, (Anti crushing) dip switch Programmable Functions
- 4) Terminal legend and general PCB schematic
- 5) Typical wiring diagram
- 6) About photocells
- 7) Programming the 909 circuit board and remotes
- 8) Self programming of working times and slowing speed
- 9) Programming automatic closing and more about remote programming
- 10,11) Radio keypad programming
- 12) Onwards,) UNAC compliance guide

The Electric Gate Shop

Obstacle detection system (anti crushing)

The 909 control board is equipped with obstacle detection and the sensitivity can be adjusted by using the trimmer marked **SENS**. This trimmer controls the level set that the gate will stop and reverse away if an obstacle is met during the normal run time. Turning the trimmer further to the – makes it more sensitive to obstacles. Turning the trimmer further to the + makes it less sensitive to obstacles. Turning the **SENS** trimmer completely to the + will disable this feature and the system will then rely solely on the **POWER** trimmer. The second level of safety is the power sent to the motors set by the trimmer marked **POWER**. Turning this trimmer further to the – sends less power to the motors and turning the trimmer further to the + sends more power to the motors. During the slowing down period the system only uses the **POWER** setting trimmer.

When the system is in operation and the gate meets an obstacle during the opening cycle, it will reverse the stroke for about 10 centimetres and it will then auto re-close after 30 seconds. If the obstacle remains, the system will try again 3 times and then finally remain open. If the automatic closing is set, it will follow the set time before closing again. If the gate is at the deceleration stage (usually around 500mm before fully open or close) it will stop and not move again until given another command. If the gate meets an obstacle while closing, it will reverse completely and it will auto re-close after 30 seconds. If the automatic closing is set, it will follow the set time. If it is at the deceleration stage, it will stop and not move again until given another command.

Full obstacle detection control throughout the full cycle of opening and closing (including the slowdown stage) can be achieved by using a safety edge, (Rib edge) through the 'F. AP with, SW2-2 OFF = NC safety edge, ON = 8K2 safety edge. Input on terminal 9. The wired safety edge system can be used with normally closed circuits and resistor 8k2 ohm circuits. Safety edges are used on gates in all areas where a specific risk of trapping may occur, especially where there is less than a 50cm gap behind a gate when fully open. Resistor 8k2 ohm circuits are used where CAT3 safety edges are needed. The 8k2 ohm circuit when installed correctly will always fail to safe if damaged shorted or open circuited.

DESCRIPTION OF THE MAIN COMPONENTS

F1	2A fuse protecting Low voltage accessories
F2	5A fuse protecting the mains power input
BREAK	Trimmer for adjusting the open pause time before automatically closing
SENS	Trimmer for adjusting the obstacle detection.+ harder, -softer, full + =off
POWER	Trimmer for adjusting the power sent to the motors
SET	Button for setting remotes and automatic work time parameters
P1	Button for setting working time
P2	Button for clearing codes with (SET) and changing START/PED logic
SW1/2	DIP switch for programming the control panel

LED'S INDICATING STATUS

PED	Always off, lights up with pedestrian control
START	Always off, lights up with start control
STOP	Always on, triggered off by stop
FOTO	Always on, triggered off by gate closing photocell
FOTO AP	Always on, triggered off by opening photocell
F.AP	Always off unless connected NC limit switch, always off when used with 8K2 limit switch
COSTA	Always off unless connected to open limit switch
FINE CH	Always off unless connected to open limit switch
The LED's status of board input can be checked after powering the control panel.	
If the lights above do not correspond, check the connections and make sure the various connected devices are working properly.	

DIP SWITCH PROGRAMMABLE FUNCTIONS

DIP SWITCH must always be programmed with the control panel switched off (not powered)



SW1	ON	OFF
1	Operation with one motor (motor 1 output enabled)	Operation with two motors
2	With faster slowdown period	With slower slowdown period
3	Disables the slowing down function	Enables the slowing down function
4	Condominium/Residential feature (while opening the control panel does not accept any other Start impulse).	Condominium/Residential feature disabled
SW2	ON	OFF
1	Enables the take off during starting 2sec. Not normally needed, but used where some gates may need this to overcome the initial inertia on start up.	Disables take off during starting
2	Enables safety edge 8K2 function	Enables safety edge without 8K2 function. NC switch type
3	Reverse push to unlock the electro-lock enable. (Not normally needed)	Reverse push disabled
4	Additional push at the end of the stroke enable. (Not normally needed)	Additional push at the end of the stroke disabled

Terminal legend

1 - 2 PED. (M1)	Pedestrian button input, N.O. contact. Open only M1	12 - 13 FLASH	Output steady warning light 230 Vac max 100 W.
1 - 3 START	In put Start (NO contact). While opening it works step by step (operators stop), while closing reverses (stop and re-open).	14 - 15 - 16 M1 (PED.)	Output motor 1 for pedestrian leaf, (14 common, 15 opening, 16 closing). 500W Max
1 - 4 STOP	STOP button input. N.C. contact input If terminal 4 circuit is broken, the gate/s will stop. If activated during the break time, the automatic closing will be cancelled	17 - 18 - 19 M2	Output motor 2 , delayed leaf in opening for gates with 2 swing leaves (17 common, 18 opening, 19 closing). 500W
5 - 7 FOTO	Photozell input active only in closing. N.C. contact (stop and reopen)	20 - 21 ALIMENT.	Input power supply 230 Vac
6 - 7 FOTOAP COSTA	Photozell for opening input, active during both opening and closing N.C. contact. In opening stop and start up again, in closing stop and reopen.	22 - 23 ANTENNA	In put antenna (22 coaxial, 23 shield).
8 - 10 FINE CH	Input limit switching opening NC contact).	24 - 25 ALIMENT.	Output 24 Vac for powering the photocells (max 500 mA).
9 - 10 FINE AP COSTA	Sensitive edge input N.C. contact. Active during both opening and closing. WITH SW2 dip 2 on, this input can use 8K2 resistor or end of line resistors..	25 - 26 ELET.SER.	Output 12 Vac for the electrolock (max 15W).
11 - 12 L.C.	Output courtesy light (90 sec.). Max 100W 230 Vac	27 - 28 SPIA	Gate movement led indicator (27= Com 28= +24V). Max 50 mA.
29 - 30	2° channel		

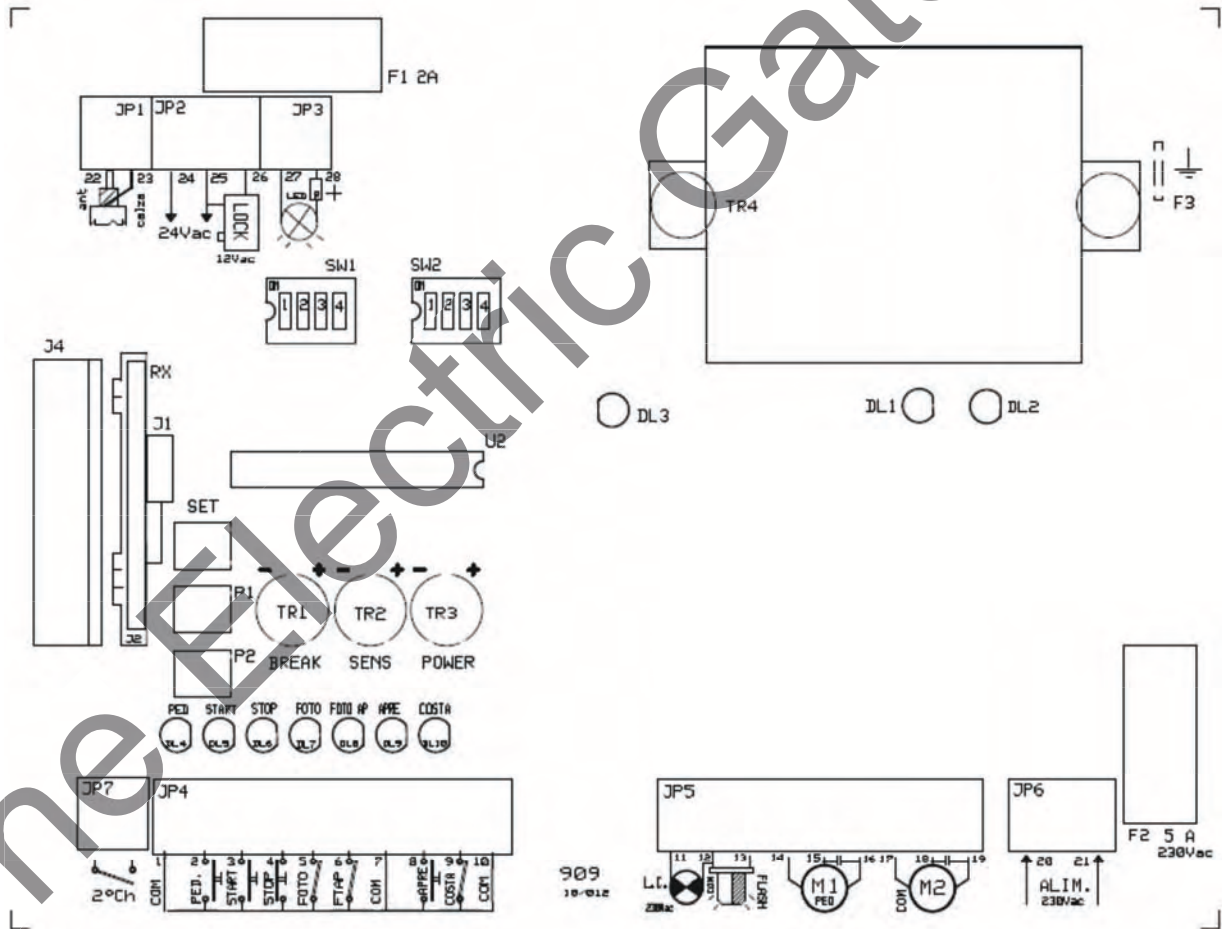

909 Typical wiring diagram

Cable Information

Main Supply 230Vac @ 6.0Amp(minimum)

Photocells, Safety Edges and Viro Lock -BT cable, CW1128 recommended.

Motors 4 Core 1.5mm²

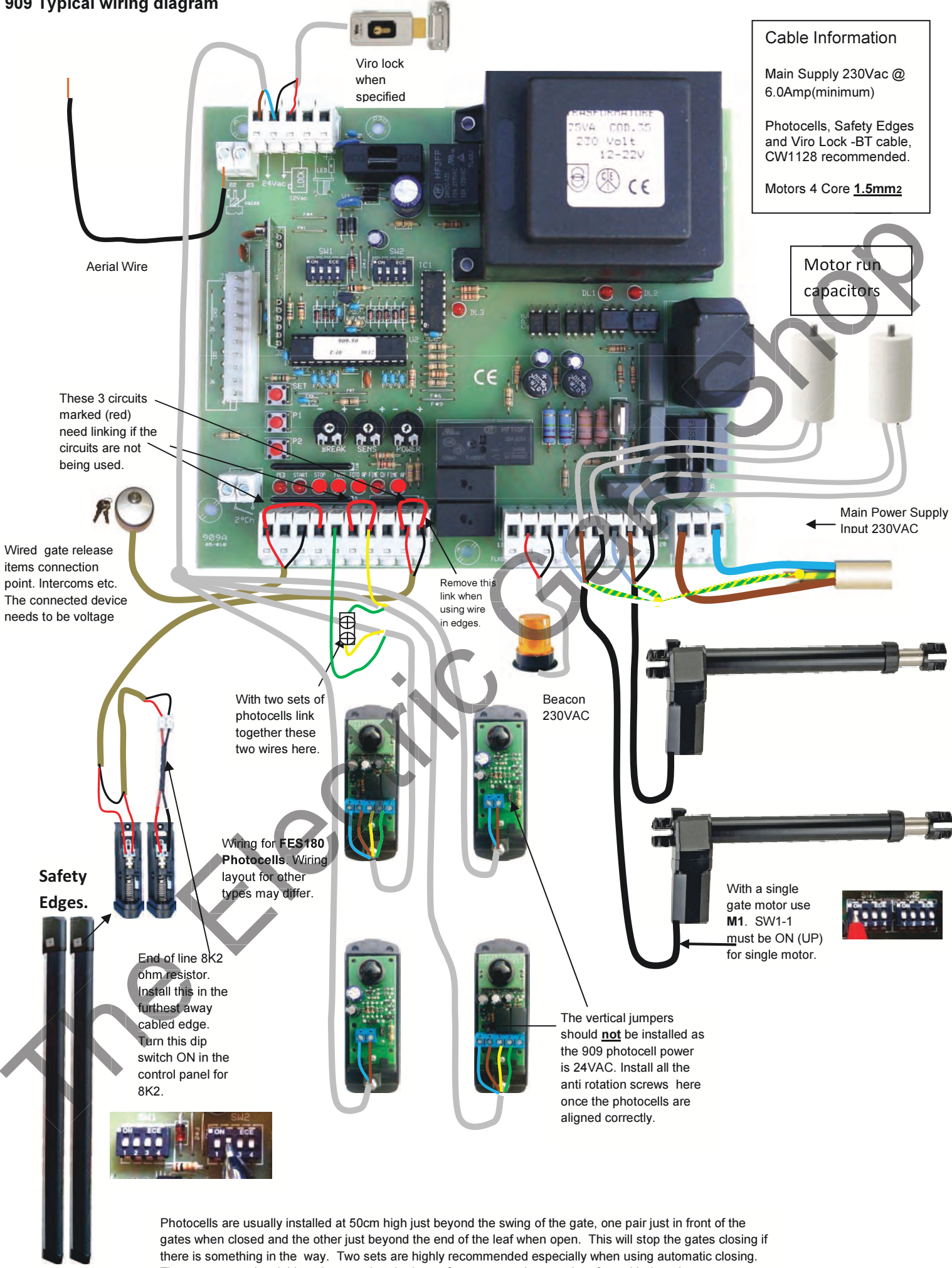

Photocells are usually installed at 50cm high just beyond the swing of the gate, one pair just in front of the gates when closed and the other just beyond the end of the leaf when open. This will stop the gates closing if there is something in the way. Two sets are highly recommended especially when using automatic closing. They are crossed as laid out here so that the beam from one set does not interfere with the other.

Photocells

The photocells are in pairs, one transmitter and one receiver. They should be mounted 500-600 mm from the ground and face each other level. Each photocell regardless of type has a 24VAC supply.

The receiving photocell does the switching on and off to the control panel. If the transmitting beam can reach the receiving photocell, there will be a completed circuit to the main panel and the gate/s will function. If the beam is broken, during operation of closing, the gates will stop and reopen.

If you are using two pairs of photocells as pictured, the receivers should be crossed on opposite sides so that you do not have two receivers at the same side.

For this purpose 4 core BT type cable is recommended for use. (CW1128) Follow the wiring diagram provided to wire both the receiver and transmitting photocells. At the control box end, wire the colour coded cables up as per the diagram provided showing a typical photocell placement.

When the photocells are working and correctly aligned, you should hear a clicking sound from the transmitter when the beam is broken intermittently. Once wired, place the covers over the photocells and secure the fixing screw. Fill any cable gaps with silicone to prevent insects from entering the device and interfering with it.

Surface Mounted Photocells

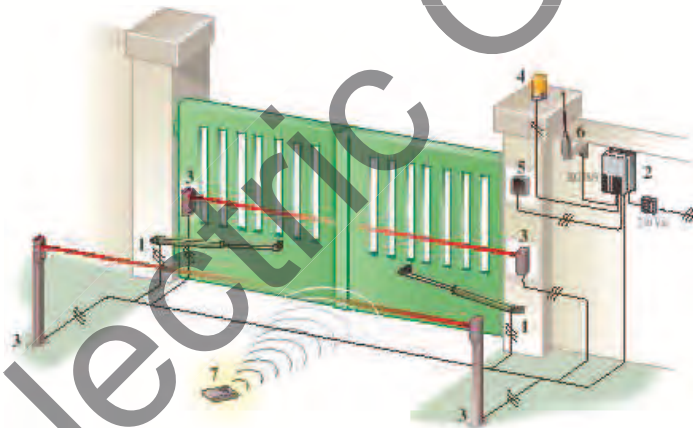

Programming the 909 circuit board

Before you start to programme!

Check that the gate wing stops are in place and set! If you are using motors with inbuilt electric limit switches, move these so they are not operational for the purpose of the test (NC). They can be re-introduced after the set up is completed

Check that you have wired the photocells correctly and bridged (linked) the normally closed (N.C) circuits that are not being used. If you have done this correctly, you should have these LEDs illuminated with the power to the circuit board on.

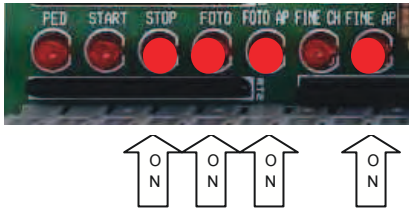

The first two LEDs from the left should only appear when a open command or a pedestrian command is given. If the fourth from the left LED is missing check your photocell wiring circuit and alignment of the beams. If any other LEDs marked ON are not illuminated, check the circuits or the links outlined on the typical wiring diagram page.

STEP1 Programming the remotes

Note Carry out programming the remotes only with the aerial disconnected from the PCB. This avoids picking up stray frequency codes from other equipment. Reconnect only when you have finished programming the remote control equipment.



STEP1 with KW113 remote,

open the cover and randomly arrange the dip-switches first.



STEP1 with A3a-V2 and I8 remotes,

Carry out the [How to generate a random code](#) procedure.

WITH JANE REMOTES GO STRAIGHT TO STEP 2

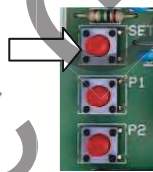

STEP2

Enter radio code programming (for the START control). Press and release the **SET** button once, the LED DL3 will start to flash. **Go to STEP3** The board accepts the code and exits from programming (DL3 turns off). It is possible to store up to a maximum of 32 different codes for the START control.



STEP3.

While the DL6 is flashing, press and hold the button on your remote you want to open the gate fully for 3 seconds.

STEP4 Verify motor direction

You need to verify that the motors are going in the right direction in relation to the panel. Arrange gate's so that they are both approximately half way. Turn the power off to the panel. (It is important that you leave the power off to the panel at least 15 seconds or the fuse may fail when you turn back on the power) Turn the power back on again. Press once the key fob that you previously learned in at step 2 and 3. Observe the direction that both gates move in at the start and then immediately turn the power off again. The gate that travels in an open direction is correct. The gate that travels in a closing direction is incorrect. Identify this motor at the PCB as M1 or M2 and these motor wires need swapping with each other. Remember, the gate that you want to open first should be connected to M1 or with a single gate use M1.

How to generate a random fob code for A3a-V2 and I8 Remotes

Press and hold button (1)

Keep button (1) pressed then press and hold button (2) (The led flashes slower)

Keep both buttons pressed for 15 seconds (The led will start to flash faster).

Whilst still holding in buttons (1) & (2), Release button (1) wait 2 seconds and release button (2).

You have now generated a random code in both buttons.

This code can now be learned to the radio receiver card.

STEP5 Self programming of working times and slowing speed

Make sure that you have end stops for each wing set. Depending on the motor type, these may be built into the motor or for motors without stops a gate wing stop will be needed. A closing floor stop, (CENTRE STOP) is highly recommended in any case because this ensures that the gates are held tight when closed. The gates will not programme or run without any stops, it needs them to figure out its positions. If the motor has built in electrical limit switches they must be moved out of the way and any lock strikes also removed while the set up procedure is being carried out.

Initial dip-switch setting for the motor slowdown. Below 350W set the dip SW1-2 ON. If you are unsure set, SW1-2 ON.



SELF-PROGRAMMING

The following describes the self-programming stages for the two gates; in the event of single gate, **M1** (DIP1 SW1 = ON), only the stages relating to motor **M1** are carried out.



- 1) Position the gate/s at fully closed and make sure the motors are locked into drive. You can check this by pulling or pushing the gate slightly, if the motor was previously un-locked, the motor will click and the gate wing will lock into drive.
- 2) Arrange the trimmers to an initial setting point. Set the BREAK trimmer to -, fully anti clockwise. Set SENS trimmer to 1 O'clock. Set the power trimmer to 1 O'clock.

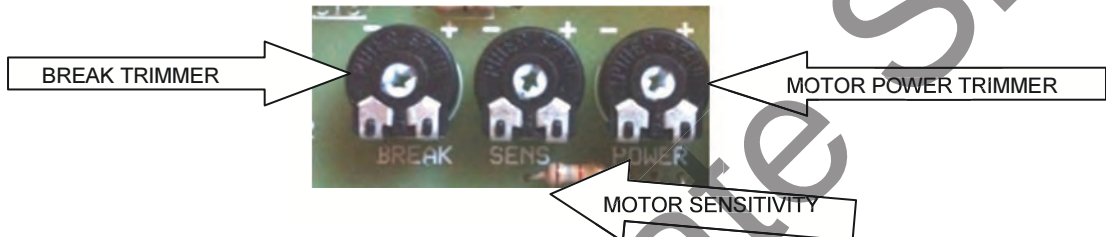

- 3) With the gates closed, turn the power off to the panel. Then at least 15 seconds later, turn the panel back on again (**It is important that you leave the power off to the panel at least 15 seconds or the fuse may fail when you turn back on.**)
- 4) Press and hold on SET DL3 will start to flash, about 15 seconds later DL3 will flash much faster and one click will emit from the board. When this happens release the SET button and the following procedures will be carried out automatically.

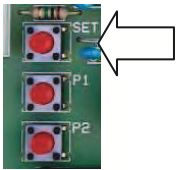

- 5) **Search for closed open position** Both leaves will open for about 4 seconds, then close again. Then board automatically searches for the "closed gate" position; the doors are moved in the closing direction until they hit the mechanical gate-closed stops forcing itself against the mechanical gate-closed stops for a few seconds).
- 6) **Search for open gate position.** The board automatically searches for the "open gate" position; the gate for motor 1 opens and after 3 seconds (fixed or preset delay) the gate for motor 2 starts to open. In order to protect the mechanical parts, the gates start to open slowly and then continue to open at the normal working speed. The gates reach the mechanical stops for the open gate position at the normal moving speed (without slowing down). The motors stop automatically after recognizing the position of the two gates, the stroke is calculated and the deceleration points are recorded.
- 7) **Gate closes** The gate automatically carries out the closing cycle. The gate starts to move slowly and then carries on to the normal speed. A fixed delay of 3 seconds is inserted before the second gate starts to move.
Deceleration of the closing gate. The gate finishes closing with the slowing down period (calculated during previous opening phase), and stops correctly on the mechanical stops.
End of self-calibration cycle. The gate is completely closed and the board exits from self-programming function (LED DL3 turns off). If the gate does not slowdown correctly or seems very weak during the slowing period, carry out the programming again with the SW1-2 in the ON position (FASTER SLOWDOWN) option enabled.

The gates can now be operated via the remote controls and the same sequence just recorded should operate every time. Fine tuning of the trimmers can now be adjusted to obtain the correct amount of POWER and obstacle SENSITIVITY to the gate wing/s by adjusting the trimmers. When the gate/s are opening or closing and are obstructed the gate/s should stop and reverse with minimal effort. It is very important that these adjustments are carried out.



In particular check that the gates detects obstacles with a minimum effort controlled by the **SENS** trimmer.

OBSERVE THE APPLICABLE PARTS OF STANDARDS EN 13241-1, EN 12453, EN 12445 TO FULLY COMPLY.

The **SENS** trimmer controls the current absorbed by the motor before the obstacle detection reverses or stops the motor.

The **POWER** trimmer controls the power sent to the motor in particular during the slowdown period. The POWER and SENS trimmers are related. If the POWER is set too low, the SENS may not be able to operate.

Check the operation of the photocells! The gate should stop and reopen, when you break the photocell beam during the closing cycle of the gate.

PROGRAMMING AUTOMATIC CLOSING

Before you change the gate/s to automatic closing, consider that the gates will be operating unattended and could close while a vehicle is within the swing area of the gates. Adding another set of photocells to the system as pictured on page 6 and wire in as page 5 wiring to prevent this situation.

PROGRAMMING AUTOMATIC CLOSING

- 1) Adjust the BREAK trimmer gradually clockwise to set the pause time before the gate starts to close again automatically. Fully anticlockwise means this function is disabled (OFF).



PROGRAMMING RADIO CODE (START CONTROL) Make sure the gate is closed.

1) Enter radio code programming (for the START control). Press and release the SET button. The LED DL3 will start to flash. Use the transmitter to send the radio code to be stored and associated with the START control. The board accepts the code and exits from programming (DL3 turns off). It is possible to store up to a maximum of 32 different codes for the START control.

PROGRAMMING RADIO CODEP (PEDESTRIAN CONTROL)

1) Enter radio code programming (for the PEDESTRIAN control). SET button twice: LED DL3 will start to flash quickly. Use the transmitter to send the radio code to be stored and associated with the PEDESTRIAN control. The board accepts the code and exits programming (DL3 turns off). It is possible to store up to a maximum of 32 different codes for the PEDESTRIAN control.

DELETING RADIO CODES: Press SET and P2 button **simultaneously** (LED DL3 will flash at a high frequency); keep them pressed for at least 10 seconds (until LED DL3 goes off), all the stored radio codes (associated with both START and PEDESTRIAN) will be deleted.

Programming additional equipment for the 909 circuit board

Radio-keypad programming

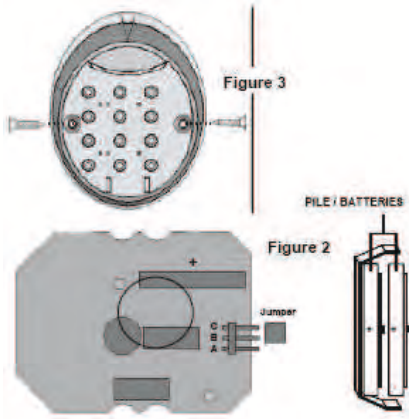

www.theelectricgateshop.co.uk/Product-1278/

SILICONE SEAL AROUND SCREW HOLES AFTER INSTALL



Drill a small weep hole here to let out any moisture.

1. Move the jumper shown in Fig. 2 to A.B from B.C. This will activate the unit
2. Install the keypad in location. Do not overtighten the screws. Overtightening can distort the pad and leave the keys inoperative
3. Dial in the following numbers to set the keypad to standard 20 mode. Dial in the numbers exactly as quoted here and ignore that the unit does not bleep every time a button is pressed during this procedure.
4. Dial in, **00000 OK 99999 OK 5**
5. With the gate/s closed, enter radio code programming (for the START control). On the 909 panel, press and release the SET button. The LED DL3 will start to flash. Dial in the numbers of your choice, (max5) and end with OK. The DL3 will go out. Dial in the same numbers again and end with OK, the gates should open.
6. With the gate/s closed enter radio code programming (for the PEDESTRIAN control). Press the SET button twice; LED DL6 will start to flash quickly. Dial in the numbers of your choice, (max5) and end with OK. The DL3 will go out. Dial in the same numbers again and end with OK, the pedestrian gate should open.

ELBE Radio-keypad programming

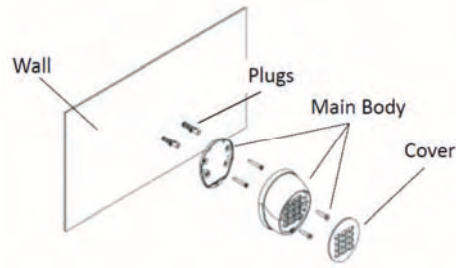

Audible Signal	Status
1 short beep	Keypad tone
1 long beep	Auto power-off
3 long beeps	Modification of combination confirmed
5 short beeps	Error during combination input or combination edit operation
10 rapid beeps	Low battery warning signal - new batteries are required

Installation

Before physically installing the unit in its mounting position it is good practice to perform a practical test to assess the functionality and effective range. Please bear in mind that range may be up to 25 or 30% less when battery power is low.

Positioning

Apart from the distance from the receiver, the units should not be positioned in the vicinity of or - worse still - in contact with metal structures, which could otherwise exert a signal shielding effect. Thanks to the enclosure protection rating of IP 54, the digital selectors can be installed outdoors if required.

A: Changing the combination associated with channel 1 ◀ - Example:

This function allows you to change the combination associated with channel 1 ◀

1. Press the "0" key and hold it down while pressing and releasing 0 ◀
2. Release the "0"key
3. Type in the current number (original factory is,11) combination and press 11 ◀
4. Type in the new combination (up to 8 digits) and press ◀ (e x a m p l e) 12345 ◀
5. Type in the new combination again 12345 ◀
6. To enter the code for the START control,. With the gate closed locate the SET button and push the button once.

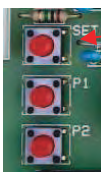

7. While DL3 is flashing, dial in the new combination generated at step 4&5, (12345) followed by the ◀symbol.

B: changing the combination associated with channel 2 ▶ - Example:

This function allows you to change the combination associated with channel 2 ▶

1. Press the "0" key and hold it down while pressing and releasing 0 ▶
2. Release the "0" key ▶
3. Type in the current (original) combination and press 22 ▶
4. Type in the new combination (up to 8 digits) and press ▶ (e x a m p l e) 23456 ▶
5. Type in the new combination again 23456 ▶
6. To enter the code for the PEDESTRIAN. With the gate closed press SET button twice; LED DL3 will start to flash quickly.
7. While DL3 is flashing, dial in the new combination generated at step 4&5, (23456) followed by the ▶symbol.

Installer:

(Name, address, telephone)

UNAC GUIDE No. 2
FOR THE MOTORISATION OF HINGED GATES
IN ACCORDANCE WITH MACHINERY DIRECTIVE 98/37/EEC AND THE APPLICABLE PARTS OF
STANDARDS EN 13241-1, EN 12453, EN 12445

With this publication UNAC sets out to inform and assist installers in applying the specifications of the directives and of European standards concerning the safe use of motorised gates/doors.

It should be noted that those who sell and *motorise* an existing manual door/gate become the manufacturer of the motorised door/gate *machine* and must prepare and keep the technical file, as laid down by Annex V of the Machinery Directive (98/37/EEC). The technical file must contain the following documents:

- Assembly drawing of the motorised door/gate (usually included in the installation manual).
- Electrical connections and control circuit diagrams (usually included in the installation manual).
- Risk analysis including (as indicated on the following pages):
 - the list of the essential requirements as indicated in Annex I of the Machinery Directive;
 - the list of the risks presented by the door/gate and the description of the solutions adopted.
- They must also keep the manuals for installation and maintenance of the door/gate and of the components.
- Prepare the operating instructions and general warnings for safety (if necessary integrating those in the manual for installation of the door/gate) and give the user a copy.
- Compile the proof book and give the user a copy (see facsimile in Annex 1).
- Draft the EC declaration of conformity (see facsimile in Annex 2) and give the user a copy.
- Fill in the label or plate with CE marking and attach it to the motorised door/gate.

N.B. The technical file must be held and made available to the competent national authorities for at least ten years from the date of construction of the motorised door/gate.

Note also that, as from May 2005, the manufacturer of a new door/gate (both manual and motorised) must observe the procedure for the CE marking pursuant to the Construction Products Directive (89/106/EEC), as indicated in annex ZA of the standard EN 13241-1. This procedure involves the manufacturer:

- setting up and maintaining internal production control;
- having a notified body carry out the initial type tests referring to the applicable characteristics indicated in Annex ZA of standard EN 13241-1.

N.B. UNAC is preparing guidelines dedicated to the correct application of the Construction Products Directive (89/106/EEC).

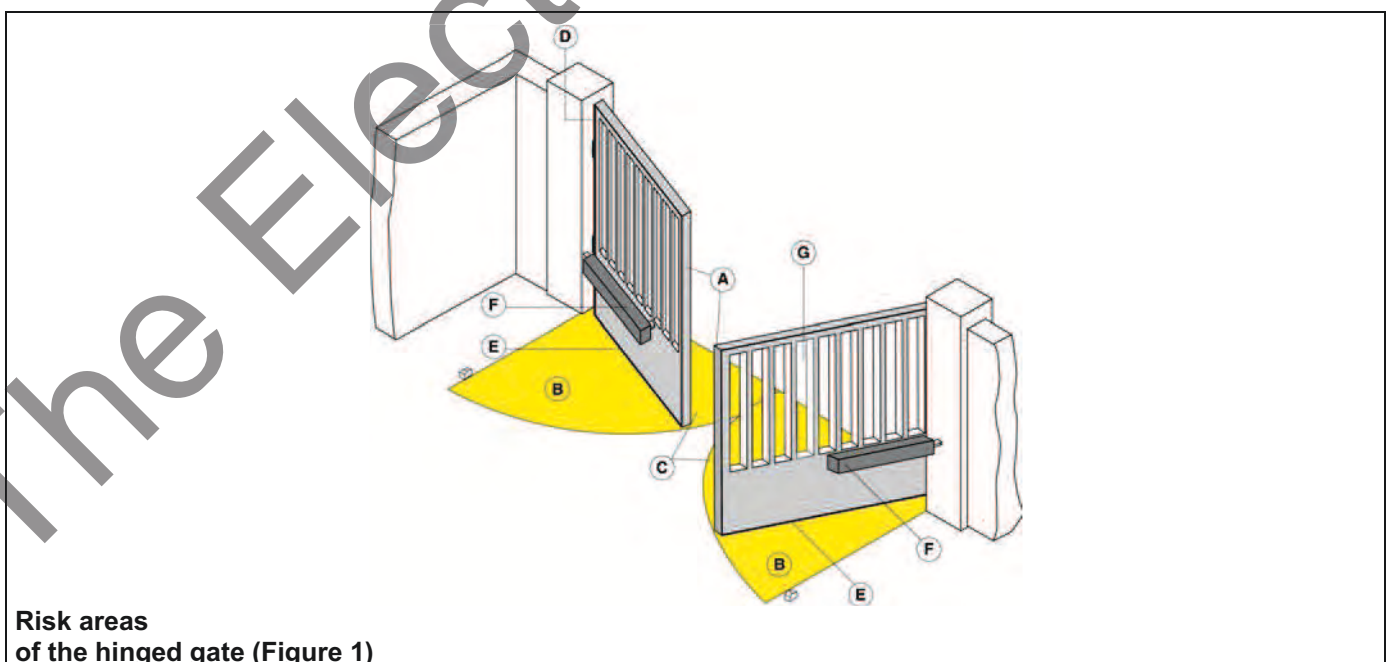

The information given was drafted and checked with the utmost care, nevertheless UNAC declines all responsibility for any errors, omissions or inaccuracies due to technical or graphical requirements. UNAC points out that this guide does not replace the content of standards which the manufacturer of the motorised door/gate must observe.

KEY TO THE MECHANICAL RISKS CAUSED BY MOVEMENT

Pursuant to the Machinery Directive:

- “Danger zones” refer to any zone within and/or around machinery in which an exposed person is subject to a risk to his or her health and safety.
- “Exposed person” refers to any person wholly or partially in a danger zone.

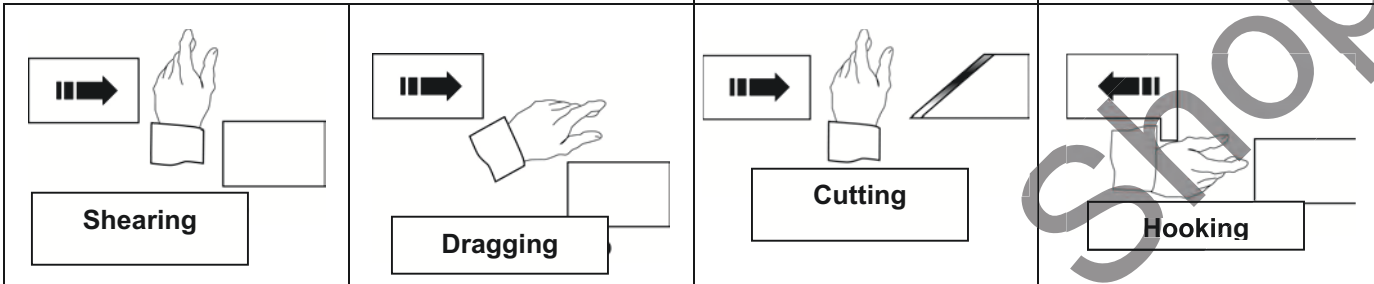
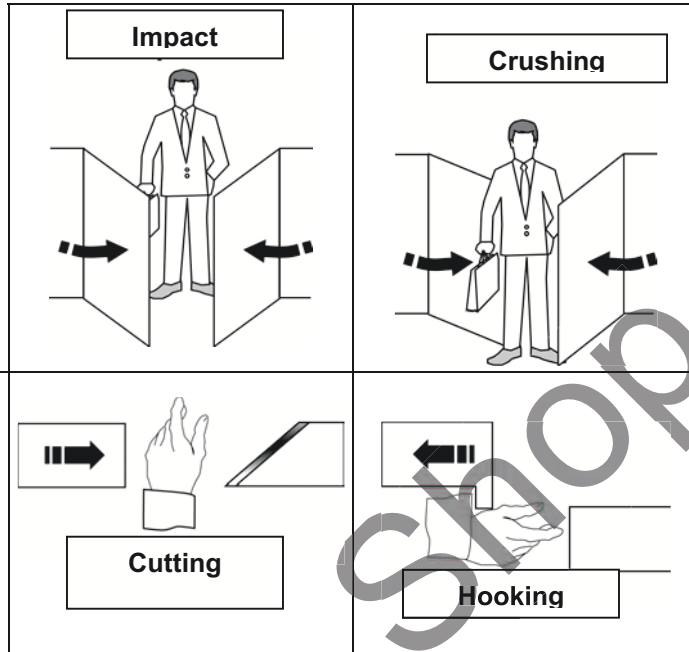

MINIMUM LEVEL OF PROTECTION OF THE MAIN EDGE

Type of actuation controls	Type of use		
	Informed users (private area)	Informed users (public area)	Uninformed users
Hold-to-run control	Pushbutton control	Pushbutton control with key	Hold-to-run control not possible
Impulse control with door visible	Limitation of forces, or presence sensing devices	Limitation of forces, or presence sensing devices	Limitation of forces and photocells, or presence sensing devices
Impulse control with door not visible	Limitation of forces, or presence sensing devices	Limitation of forces and photocells, or presence sensing devices	Limitation of forces and photocells, or presence sensing devices
Automatic control (e.g. timed closure control)	Limitation of forces and photocells, or presence sensing devices	Limitation of forces and photocells, or presence sensing devices	Limitation of forces and photocells, or presence sensing devices

ANALYSIS OF THE RISKS AND CHOICE OF SOLUTIONS

IN ACCORDANCE WITH THE MACHINERY DIRECTIVE 98/37/EEC AND THE STANDARDS EN 13241-1, EN 12453, EN 12445

The risks listed below follow the sequence of the installation process. These risks are those which are commonly present in motorised doors/gates systems. According to the various situations, consideration therefore has to be made of any possible additional risks and exclude those which are not applicable. The solutions to be adopted are those indicated by the standards mentioned above; in the case of risks not dealt with, the safety integration principles indicated by the Machinery Directive (Annex 1 – 1.1.2) have to be applied.

MD Ann. 1	Type of risks	Evaluation criteria and solutions to be adopted (Tick the box corresponding to the solution adopted)
1.3.1 1.3.2	<i>Mechanical, structural and wear risks.</i> [1] Loss of stability and break-up.	<input type="checkbox"/> Check the solidity of the structure installed (jambs, hinges and leaves) in relation to the forces generated by the motor. Attach the motor stably using adequate materials. If available, check the content of the EC declaration of conformity of the manual gate. <input type="checkbox"/> If necessary, carry out the structural calculation and attach it to the Technical File. <input type="checkbox"/> Check that the travel of the leaves is limited (during opening and closure) by mechanical stops of adequate strength. Check that the leaves cannot, under any circumstance, exit their slide guides and fall.
1.5.15	[2] Tripping.	<input type="checkbox"/> Check that any thresholds higher than 5 mm are visible, indicated or shaped.

MD Ann. 1	Type of risks	Evaluation criteria and solutions to be adopted (Tick the box corresponding to the solution adopted)
1.3.7 1.3.8 1.4	<p>Mechanical risks caused by the movement of the gate (see references in Figure 1).</p> <p><input type="checkbox"/> CAUTION – If the door/gate is used solely with hold-to-run controls (and meets the requirements of the standard EN 12453), the danger points listed below do not have to be protected.</p> <p><input type="checkbox"/> CAUTION – If protective devices are installed (in accordance with the standard EN 12978) which prevent in all cases contact between the moving leaf and persons (for example photoelectric barriers, presence sensing devices), it is not necessary to measure the operating forces.</p>	

[3] Impact and crushing on the main closing edge (Figure 1, risk A).

Measure the closure forces (by means of the special instrument required by the standard EN 12445) as illustrated.

In the case of gates with two leaves, the closure force should be measured one leaf at a time.

Check that the values measured by the instrument are below those indicated in the graph.

Carry out the measurements in the following points:
 L = 50, 300 and 500 mm;
 H = 50 mm,
 at mid-height of the leaf and
 at the height of the leaf minus 300 mm (max 2500).

N.B. The measurement should be repeated three times in each point and the average value considered.

The graph indicates the maximum values of the dynamic, static and residual operating forces in relation to the various positions of the leaf.

N. B. With reference to the measurement points with L = 50, 300 and 500 mm, the maximum dynamic force value permitted is 400 N.

If the values of the forces are higher, install a protective device in accordance with the standard EN 12978 (for example a sensitive edge) and repeat the measurement.

N. B. The dynamic force can be reduced, for example, by reducing the speed of the leaf or using a sensitive edge with high elastic deformation.

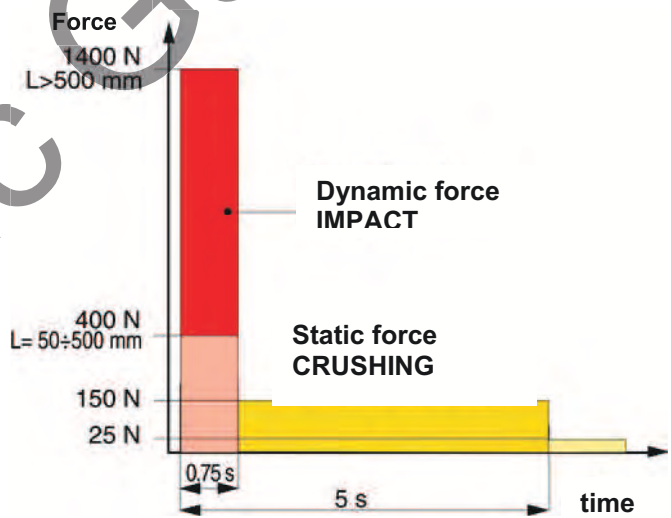
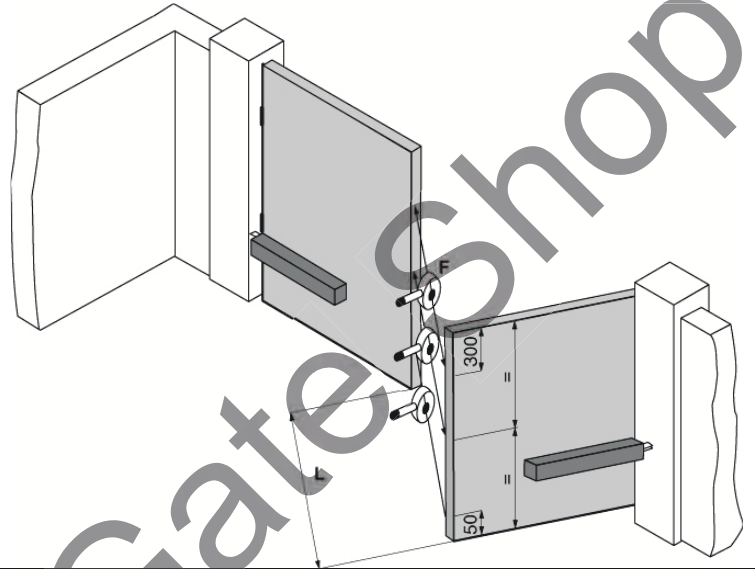

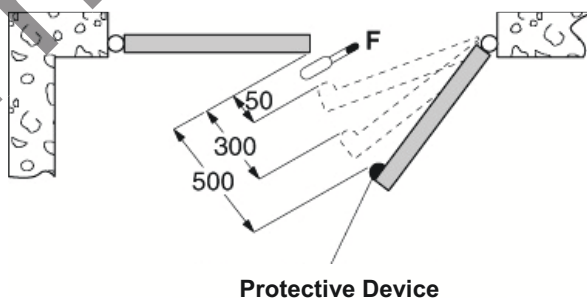

Leaves with overlapping and delayed closure

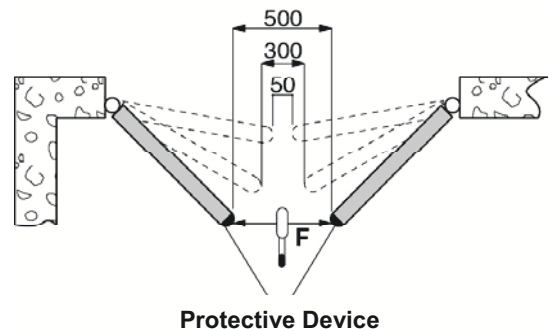

Leaves with simultaneous closure

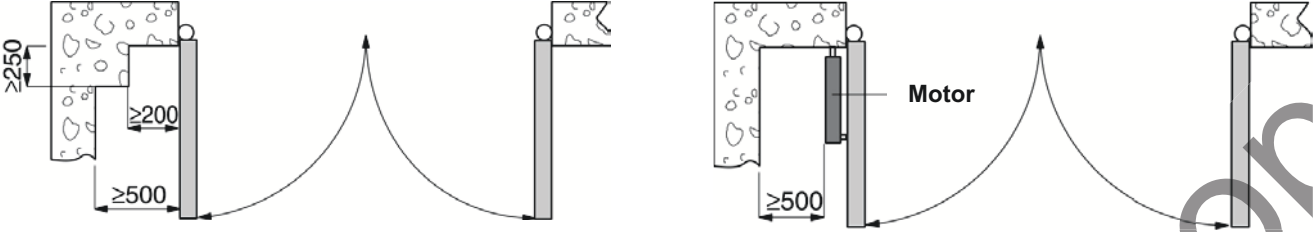
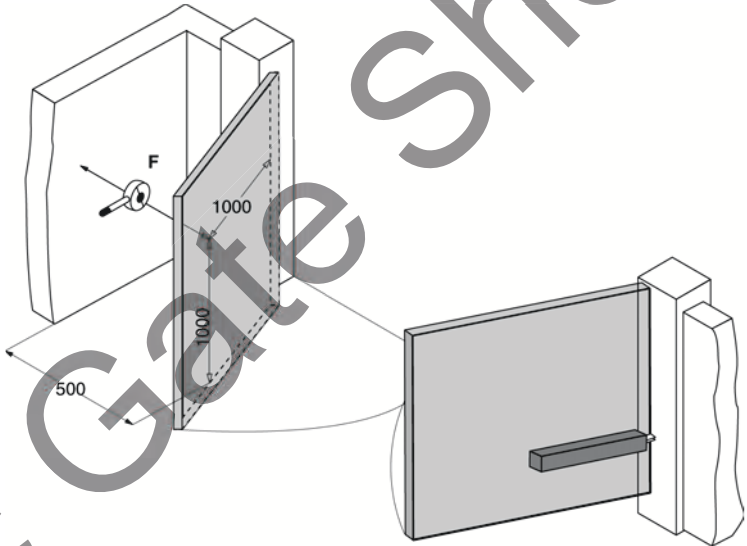
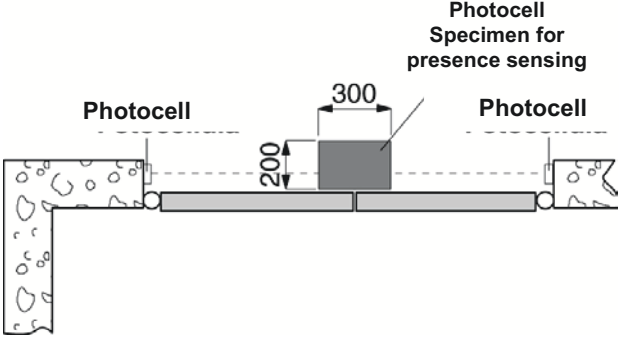
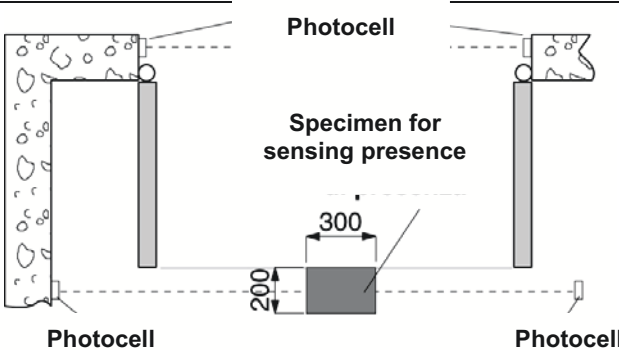

MD Ann. 1	Type of risks considered	Evaluation criteria and solutions to be adopted (Tick the box corresponding to the solution adopted)
<p>[4] Impact and crushing in the area of opening (Figure 1, risk B).</p> <p><input type="checkbox"/> Observe the safety distances illustrated (in the most prominent part of the leaf).</p> 		
<p>or:</p> <p><input type="checkbox"/> Measure the forces of opening (by means of the special instrument required by the standard EN 12445) as illustrated. Check that the values measured by the instrument are less than those indicated in the graph above.</p> <p>Carry out the measurement at a height of 1000 mm (or in the most prominent point of the leaf)</p> <p><i>N.B. The measurement should be repeated three times and the average value considered.</i></p> <p><input type="checkbox"/> If the values of the forces are higher, install a protective device in accordance with the standard EN 12978 (for example a sensitive edge) and repeat the measurement.</p> 		
<p>[5] Impact in the area of closure (Figure 1, risk C).</p> <p><input type="checkbox"/> Install a pair of photocells (recommended height 500 mm) so as to sense the presence of the test parallelepiped (height 700 mm) positioned as illustrated.</p> <p><i>N.B. The test specimen for presence sensing is a parallelepiped (700 x 300 x 200 mm) with 3 faces with a light and reflective surface and 3 faces with a dark and opaque surface.</i></p> 		
<p>[6] Impact in the area of opening (Figure 1, risk B) and in the area of closure (Figure 1, risk C)</p> <p><input type="checkbox"/> To reduce further the possibility of impact in the areas of movement of the gate, it is possible to install a pair of photocells (recommended height 500 mm) so as to sense the presence of the test parallelepiped (height 700 mm) positioned as illustrated.</p> 		

MD Ann. 1	Type of risks	Evaluation criteria and solutions to be adopted (Tick the box corresponding to the solution adopted)
1.3.7 1.3.8 1.4	<p><i>Mechanical risks due to movement of the leaf.</i></p> <p>[7] Dragging of the hands on the hinges side edge (Figure 1, risk D).</p> <p>[8] Dragging of the feet on the lower edge (Figure 1, risk E).</p> <p>[9] Dragging of the hands on the drive unit (Figure 1, risk F).</p> <p>[10] Dragging, hooking and cutting due to the shaping of the mobile leaf (Figure 1, risk G).</p>	<p><input type="checkbox"/> Check that there is a clearance ≥ 25 mm,</p> <p>or:</p> <p><input type="checkbox"/> attach guards that prevent fingers from being inserted (for example a rubber strip).</p> <p><input type="checkbox"/> The clearance between the gate and ground must prevent the risk of dragging of the feet.</p> <p><i>N.B. Should, due to the slope of the ground, the clearance vary, guards should be attached (e.g. rubber strips).</i></p> <p><input type="checkbox"/> If the distances between the drive unit and the leaf vary, check on the presence of a clearance ≥ 25 mm, or attach guards (e.g. covers or strips in rubber).</p> <p><input type="checkbox"/> Eliminate or protect any sharp edges, handles, projecting parts etc. (for example by means of covers or strips in rubber).</p>
1.5.1 1.5.2 1.5.10 1.5.11	<p><i>Electrical and electromagnetic compatibility risks</i></p> <p>[11] Direct and indirect contacts. Dispersion of electrical energy.</p> <p>[12] Risks relating to electromagnetic compatibility.</p>	<p></p> <p><input type="checkbox"/> Use CE-marked components and materials pursuant to the Low Voltage Directive (73/23/EEC).</p> <p><input type="checkbox"/> Carry out the electrical connections, connection to the mains, earth connections and relevant checks, in accordance with current regulations and as indicated in the installation manual of the drive unit.</p> <p><i>N.B. If the electrical supply line is already set up (via both a socket and a connector block), declarations of conformity to Italian law no. 46/90 are not necessary.</i></p> <p><input type="checkbox"/> Use CE-marked components pursuant to the EMC Directive (89/336/EEC). Carry out the installation as indicated in the manual for installation of the drive unit.</p>
1.2 1.5.3 1.2.3 1.2.4	<p><i>Safety and reliability of drive unit and control and safety devices.</i></p> <p>[13] Safety conditions in the event of malfunctioning and power failure.</p> <p>[14] Energy types other than electrical energy</p> <p>[15] Actuation and disabling of the drive unit.</p> <p>[16] Power supply switch.</p>	<p><input type="checkbox"/> Use drive units which comply with the standard EN 12453 and safety devices which comply with the standard EN 12978.</p> <p><input type="checkbox"/> If hydraulic drive units are used, they must comply with the standard EN 982; or</p> <p><input type="checkbox"/> if pneumatic drive units are used, they must comply with the standard EN 983.</p> <p><input type="checkbox"/> Check that, after a fault or power failure, the drive unit restarts safely without creating hazardous situations.</p> <p><input type="checkbox"/> Install an omnipolar switch for electrical insulation of the door/gate, in accordance with current laws. This switch must be positioned and protected against accidental or unauthorised actuation.</p>

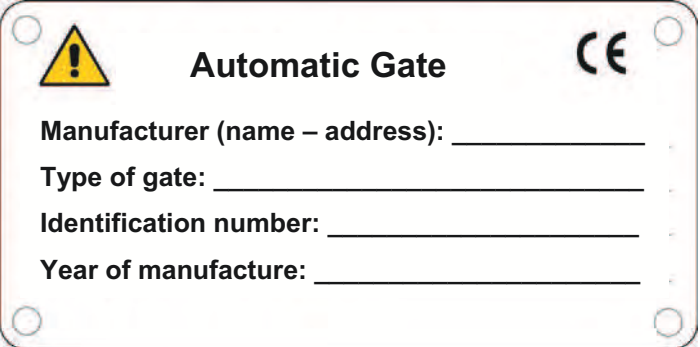
MD Ann. 1	Type of risks	Evaluation criteria and solutions to be adopted (Tick the box corresponding to the solution adopted)
1.2.5	[17] Consistency of controls	<input type="checkbox"/> Install the controls (e.g. key selector) so that the user is not in a danger zone, and check that the meaning of the controls has been understood by the user (for example the function selector). <input type="checkbox"/> Use CE-marked radio controls pursuant to the R&TTE directive (1999/5/EEC) and complying with the frequencies admitted by the laws of each individual country.
1.5.14	[18] Risk of trapping.	<input type="checkbox"/> Install a device for release of the drive unit that allows manual opening and closure of the leaf with force no higher than 225 N (for doors/gates in residential areas) or 390 N (for doors/gates in industrial or commercial areas). Supply the user with the means and instructions for the release operations. Check that operation of the release device is simple and does not create additional risks.
1.2.4	[19] Emergency stop.	<input type="checkbox"/> If appropriate, install an emergency stop control in accordance with the standard EN 418. <i>N.B. Make sure that the emergency stop does not introduce additional risks, aborting operation of the safety devices installed.</i>
1.7.1 1.7.2 1.7.3 1.7.4 1.6.1 1.1.2	<i>Integration principles for safety and information.</i> [20] Signalling equipment. [21] Warnings. [22] Marking. [23] Operating instructions. [23] Maintenance. [24] Unprotected residual risks.	<input type="checkbox"/> A flashing light should be installed, in a visible position, to indicate movement of the leaf. <input type="checkbox"/> Traffic lights can be installed to control vehicle traffic. <input type="checkbox"/> Reflectors can also be attached to the leaf. <input type="checkbox"/> Attach all those signs or warnings considered necessary for indicating any unprotected residual risks and to indicate any foreseeable improper use. <input checked="" type="checkbox"/> Attach the label or plate with the CE marking and containing at least what is shown in the illustration. <div data-bbox="715 1308 1417 1653" style="border: 1px solid black; padding: 10px; margin: 10px 0;">  </div> <input type="checkbox"/> Consign to the user the operating instructions, safety warnings and EC declaration of conformity (cf. facsimile in Annex 2). <input type="checkbox"/> A maintenance plan has to be drawn up and implemented. Check on the proper working of the safety devices at least every 6 months. <input type="checkbox"/> Record the work carried out in the proof book in accordance with the standard EN 12635 (cf. facsimile in Annex 1). <input type="checkbox"/> Inform the user in writing (for example in the operating instructions) of any unprotected residual risks and foreseeable improper use.