

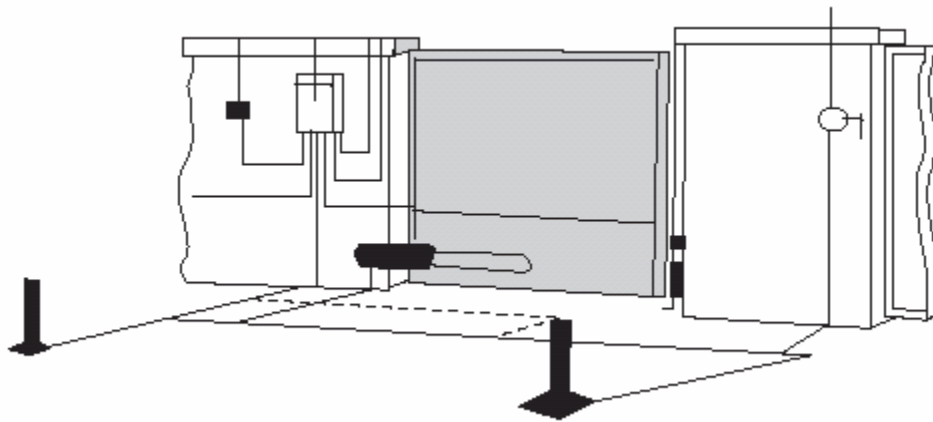

EAGLE-E7

SWING GATE OPERATOR



Eagle-E7 Swing Gate Operator
For Single & Dual Swing Gates to 16' 700 lbs

Eagle-E7 Short Swing Gate Operator
For Single & Dual Swing Gates to 10' 600 lbs

No Power? No Problem!



100 Cycles of Battery
Back-up Operation



TABLE OF CONTENTS

UL Listings

Important Safety Information3
Requirements for UL Compliant Installation.....3
UL 325 Classifications5
Required Entrapment Protection5

Installation

Operator & Gate Overview6
Preliminary Information.....6
Measurements for Mounting7
 Standard Installation, Push-to-Open Installation
Mounting Brackets9
Attaching Gate Operator Arm 10
Adjusting Open & Close Limit 11
Wiring the Gate Operator Arm..... 12
Auto Power Save Mode—Auxiliary Power..... 13
Loop Detectors..... 14
Power Fail Operation 15
 Battery Back-up Operation
 Complete Battery Discharge
 Hold-Open / Hold-Closed During Power Failure
Feature Selector..... 18

UL LISTINGS

IMPORTANT SAFETY INFORMATION

⚠ WARNING

To reduce the risk of **INJURY** or **DEATH** read and follow the instructions

1. Never let children operate or play with gate controls. Keep the remote control away from children.
2. Always keep people and objects away from the gate. **NO ONE SHOULD CROSS THE PATH OF THE MOVING GATE.**
3. Test the gate operator monthly. The gate **MUST** reverse on contact with a rigid object or stop when an object activates the non-contact sensors. After adjusting the force or the limit of travel, re-test the gate operator. Failure to adjust and re-test the gate operator properly can increase the risk of injury or death.
4. Use the emergency release only when the gate is not moving.
5. **KEEP GATES PROPERLY MAINTAINED.** Read the owner's manual. Have a qualified service person make repairs to gate hardware.
6. The entrance is for vehicles only. Pedestrians must use separate entrance.
7. **SAVE THESE INSTRUCTIONS.**

REQUIREMENTS FOR UL COMPLIANT INSTALLATION

1. Install the gate operator only when:
 - a) The operator is appropriate for the construction of the gate and the usage class of the gate.
 - b) All openings of a horizontal slide gate are guarded or screened from the bottom of the gate to a minimum of 4 feet (1.22 m) above the ground to prevent a 2-1/4 inch (57.2 mm) diameter sphere from passing through the openings anywhere in the gate, and in that portion of the adjacent fence that the gate covers in the open position.
 - c) All exposed pinch points are eliminated or guarded, and
 - d) Guarding is supplied for exposed rollers.
2. The operator is intended for installation only on gates used for vehicles. Pedestrians must be supplied with a separate access opening. The pedestrian access opening shall be designed to promote pedestrian usage. Locate the pedestrian gate such that persons will not come in contact with the vehicular gate during the entire path of travel of the vehicular gate.
3. The gate must be installed in a location so that enough clearance is supplied between the gate and adjacent structures when opening and closing to reduce the risk of entrapment. Swinging gates shall not open into public access areas.
4. The gate must be properly installed and work freely in both directions prior to the installation of the gate operator. Do not over-tighten the operator clutch or pressure relief valve to compensate for a damaged gate.

UL LISTINGS

REQUIREMENTS FOR UL COMPLIANT INSTALLATION (continued)

5. For gate operators utilizing Type D protection:
 - a) The gate operator controls must be placed so that the user has full view of the gate area when the gate is not moving.
 - b) The placard provided marked in letters at least 1/4 in. [6.4-mm] high with the word "WARNING" and the following statement or the equivalent: "Moving Gate Has the Potential of Inflicting Injury or Death – Do Not Start Gate Unless Path is Clear" shall be placed adjacent to the controls.
 - c) An automatic closing device (such as a timer, loop sensor, or similar device) shall not be employed, and
 - d) No other activation device shall be connected.
6. Controls intended for user activation must be located at least six feet [6'] away from any moving part of the gate and where the user is prevented from reaching over, under, around or through the gate to operate the controls. Outdoor or easily accessible controls shall have a security feature to prevent unauthorized use.
7. The Stop and /or Reset button must be located in the line-of-sight of the gate. Activation of the reset control shall not cause the operator to start.
8. A minimum of two (2) **WARNING SIGNS** shall be installed, one on each side of the gate where easily visible.
9. For gate operators utilizing a non-contact sensor in accordance with Usage Class:
 - a) See instructions on the placement of non-contact sensors for each type of application.
 - b) Care shall be exercised to reduce the risk of nuisance tripping, such as when a vehicle trips the sensor while the gate is still moving, and
 - c) One or more non-contact sensors shall be located where the risk of entrapment or obstruction exists, such as the perimeter reachable by a moving gate or barrier.
10. For gate operators utilizing a contact sensor in accordance with Usage Class:
 - a) One or more contact sensors shall be located where the risk of entrapment or obstruction exists, such as at the leading edge, trailing edge, and post-mounted both inside and outside of a vehicular horizontal slide gate.
 - b) One or more contact sensors shall be located at the bottom edge of a vehicular vertical lift gate.
 - c) One or more contact sensors shall be located at the pinch point of a vehicular vertical pivot gate.
 - d) A hardwired contact sensor shall be located and its wiring arranged so that the communication between the sensor and the gate operator is not subjected to mechanical damage.
 - e) A wireless contact sensor such as one that transmits radio frequency (RF) signals to the gate operator for entrapment protection functions shall be located where the transmission of the signals are not obstructed or impeded by building structures, natural landscaping or similar obstruction. A wireless contact sensor shall function under the intended end-use conditions.
 - f) One or more contact sensors shall be located on the inside and outside leading edge of a swing gate. Additionally, if the bottom edge of a swing gate is greater than 6 inches [152 mm] above the ground at any point in its arc of travel, one or more contact sensors shall be located on the bottom edge.
 - g) One or more contact sensors shall be located at the bottom edge of a vertical barrier (arm).

UL LISTINGS

UL 325 MODEL CLASSIFICATIONS



Class I (Residential Vehicular Gate Operator) - A vehicular gate operator (opener or system) intended for use in a home of one to four single family dwellings, or a garage or parking area associated therewith.



Class II (Commercial/General Access Vehicular Gate Operator) - A vehicular gate operator (opener or system) intended for use in a commercial location or building such as a multi-family housing unit (five or more single family units), hotel, garages, retail store, or other buildings servicing the general public.

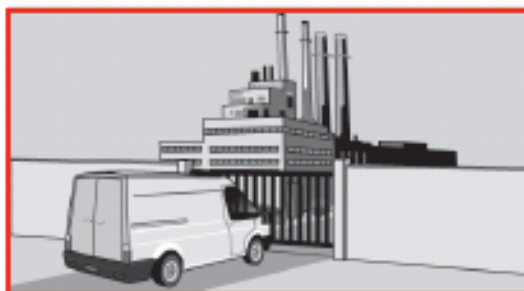

Class III (Industrial/Limited Access Vehicular Gate Operator) - A vehicular gate operator (opener or system) intended for use in an industrial location, loading dock area, or other location not intended to service the general public.



Class IV (Restricted Access Vehicular Gate Operator) - A vehicular gate operator (opener or system) intended for use in a guarded industrial location or buildings such as airport security area or other restricted access locations not servicing the general public, in which unauthorized access is prevented via supervision by security personnel.

UL 325 REQUIRED ENTRAPMENT PROTECTION

Entrapment Protection Requirements For Each UL 325 Classification

Proper installation must satisfy the entrapment protection chart as shown. The installation must have one **PRIMARY** means and one **SECONDARY** means of entrapment protection in both the **OPEN** and **CLOSE** direction of gate travel.

A - Inherent (built into the gate operator) Entrapment Protection System, and at least one of the following as indicated on chart
B1 - Non-contact Sensor such as photo-eye or equivalent
B2 - Contact Sensor such as edge sensor or equivalent

C - Inherent Adjustable Clutch or Pressure Relief Device
D - Actuating Device requiring continuous pressure to maintain gate motion
E - Inherent Audio Alarm

GATE TYPE	PROTECTION	CLASS I & II	CLASS III	CLASS IV
HORIZONTAL SLIDE, VERTICAL LIFT, VERTICAL PIVOT GATE	Primary Type	A	A, B1, B2	A, B1, B2, D
	Secondary Type	B1, B2, D	A, B1, B2, D, E	A, B1, B2, D, E
SWING GATE OR VERTICAL BARRIER (ARM)	Primary Type	A, C	A, B1, B2, C	A, B1, B2, C, D
	Secondary Type	A, B1, B2, C, D	A, B1, B2, D, E	A, B1, B2, C, D, E

INSTALLATION

OPERATOR & GATE OVERVIEW

Gate Size & Weight Requirements (Gate must operate freely)

Operator Model	Gate Leaf Width	Gate Leaf Weight
Eagle-E7	8'	900 lbs
	10'	800 lbs
	16'	700 lbs

Operator Model	Gate Leaf Width	Gate Leaf Weight
Eagle-E7 SHORT	6'	800 lbs
	10'	600 lbs

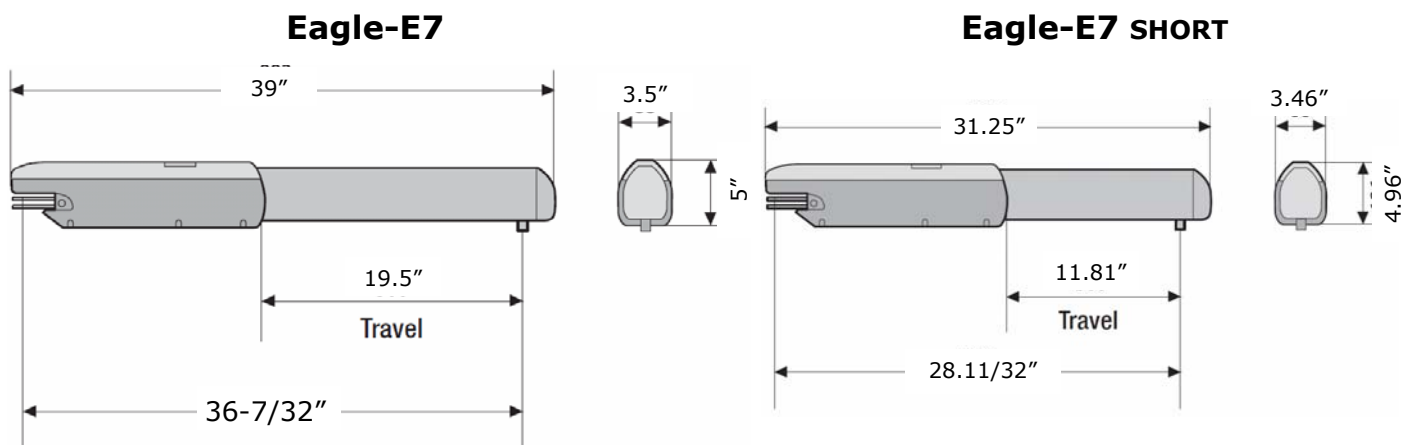

PRELIMINARY INFORMATION

Before installation, be sure that

- Gate posts, hinges, and gate construction, is sufficient to support the gates and the gate operators,
- Gates swing freely and there is no friction or obstruction between moving parts,
- Measurement C (below) is not greater than the value shown. Modification to the pillar is required to comply with corresponding measurements.

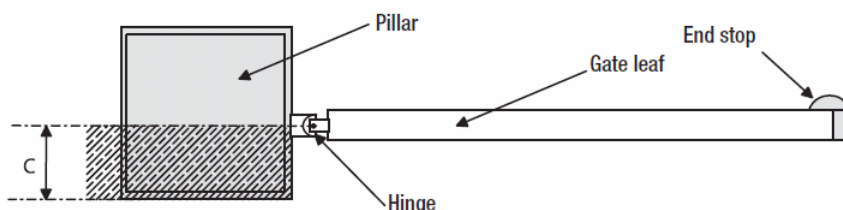

MODEL	DIMENSION C
EAGLE-E7	
90° OPEN	2-3/8"
130° OPEN	2"
EAGLE-E-7 SHORT	
90° OPEN	4-3/4"
130° OPEN	2-3/4"

INSTALLATION

MEASUREMENTS FOR MOUNTING

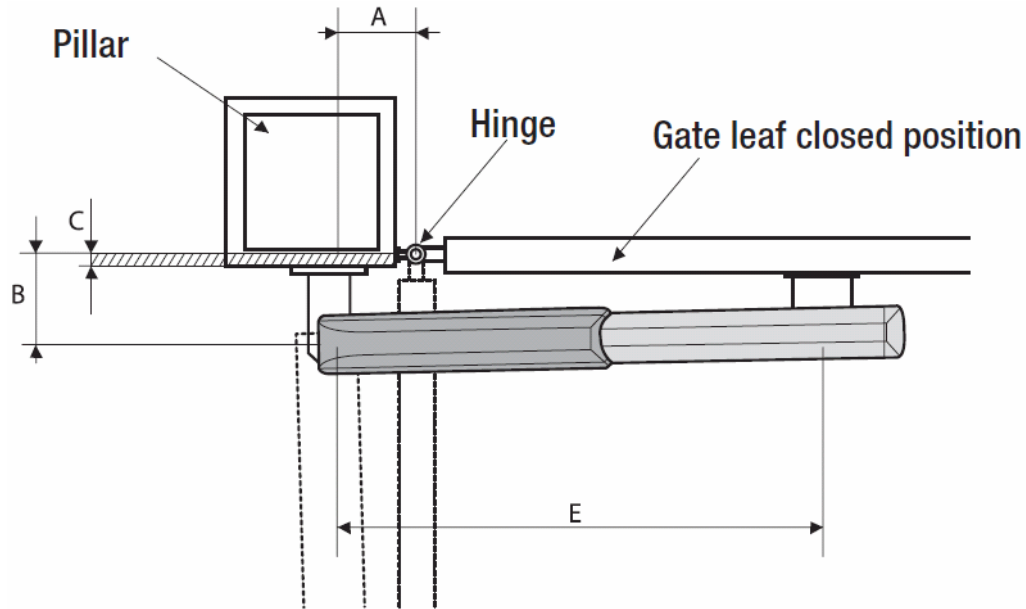

Important

Note: The following are example applications. Your application may vary.

It is the installer's responsibility to choose the most suitable dimensions based on site-specific issues.

Use "A Compact" dimension only when necessary.

EAGLE-E7 — GATE LEAF TO 16'					
Opening	A	A (Compact)	B	C (MAX)	E
90°	7-3/4"	5"	7-3/4"	4-3/4"	36-7/32"
120°	7-3/4"	5"	5-1/2"	2-3/4"	36-7/32"

EAGLE-E7 SHORT — GATE LEAF TO 10'					
Opening	A	A (Compact)	B	C (MAX)	E
90°	5"	4-1/2"	5"	2-1/4"	28-11/32"
120°	5"	4-1/2"	4-1/4"	2"	28-11/32"

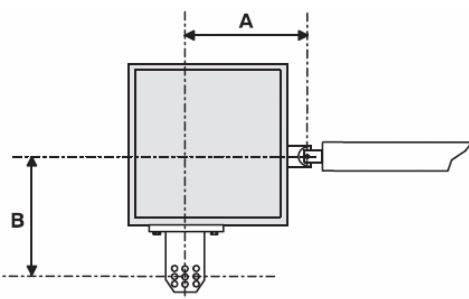

Note: When attaching the Anchoring Plate & Back Bracket, make sure the A and B measurements are correct between the hinge axis and central bore hole on the Back Bracket.

The Back Bracket has several holes for changing the opening angle of the gate.

- Increasing the B measurement decreases the opening angle resulting in slower peripheral speed and greater motor thrust on the gate leaf.
- Increasing measurement A increases the opening angle resulting in greater peripheral speed and reduced motor thrust on the gate leaf.

INSTALLATION

MEASUREMENTS FOR MOUNTING (CONTINUED)

Optional Method: Push Gate Open

Note: The following are example applications. Your application may vary.

It is the installer's responsibility to choose the most suitable dimensions based on site-specific issues.

Measure the length of measurement A and B (See Dimensions This Page). Connect the Rear Bracket and Supplemental Bracket to proper dimensions. Mount to column.

Open the gate to the full open position (Maximum 90°) and measure E.

Connect to the front bracket.

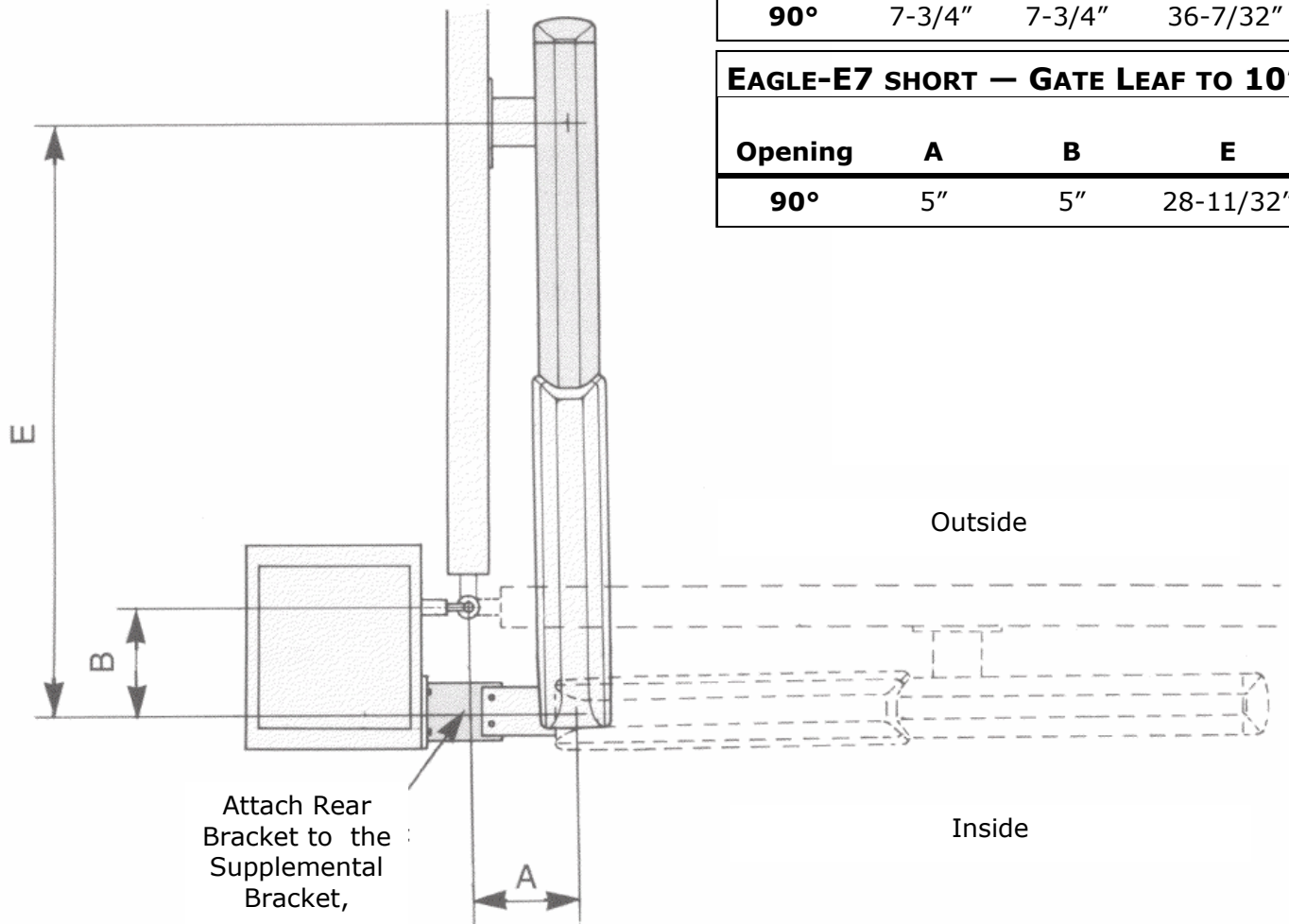

EAGLE-E7 — GATE LEAF TO 16'			
Opening	A	B	E
90°	7-3/4"	7-3/4"	36-7/32"

EAGLE-E7 SHORT — GATE LEAF TO 10'			
Opening	A	B	E
90°	5"	5"	28-11/32"

INSTALLATION

MOUNTING BRACKETS

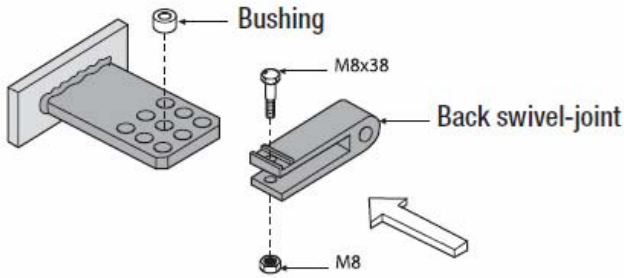

Attach the anchoring plate to the pillar using the Back Bracket. Make sure the A and B measurements are correct (See Measurements Previous Page) between the hinge axis and central bore hole on the bracket.

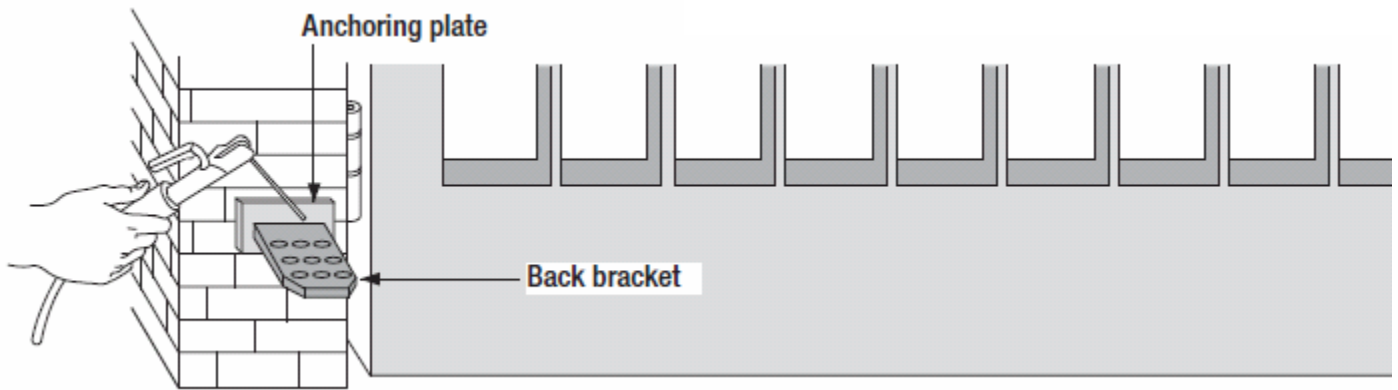

Note: With the gate in the closed position, attach the Anchoring Plate & Front Bracket to the gate leaf, making sure that the Front Bracket is level with the Back Bracket. Ensure proper dimension E (See Measurements Previous Page).

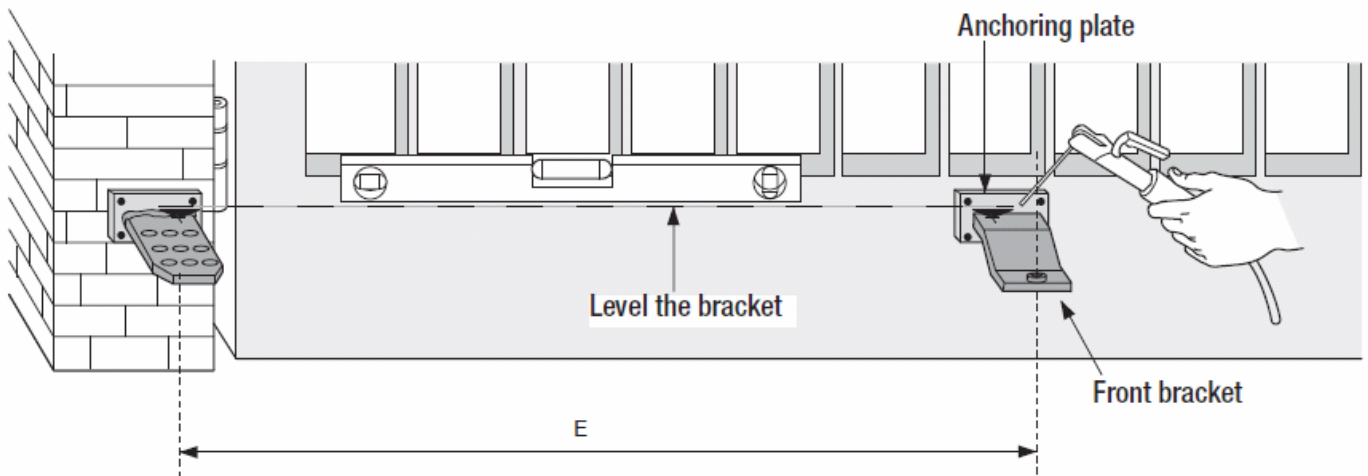

INSTALLATION

ATTACHING GATE OPERATOR ARM

Step 1. Unscrew 2 screws to remove Gear motor Housing Cover

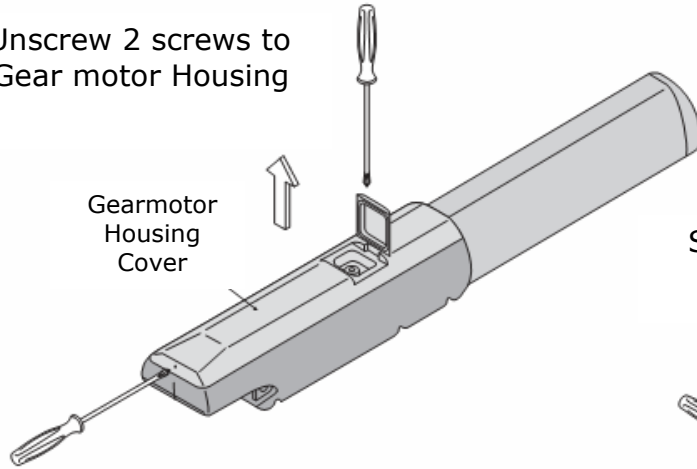

Step 2. Unscrew 2 screws to remove Screw Drive Cover

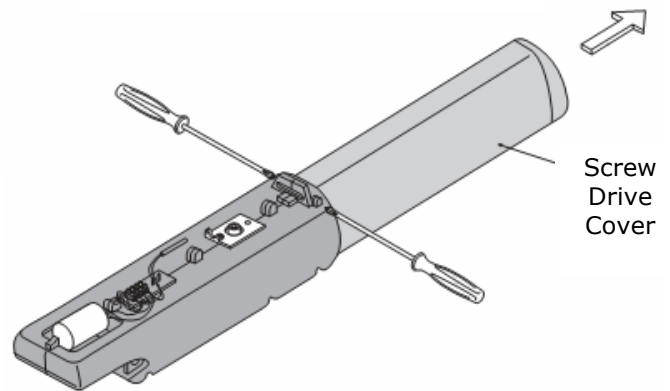

Step 3. Mount to Front & Back Brackets

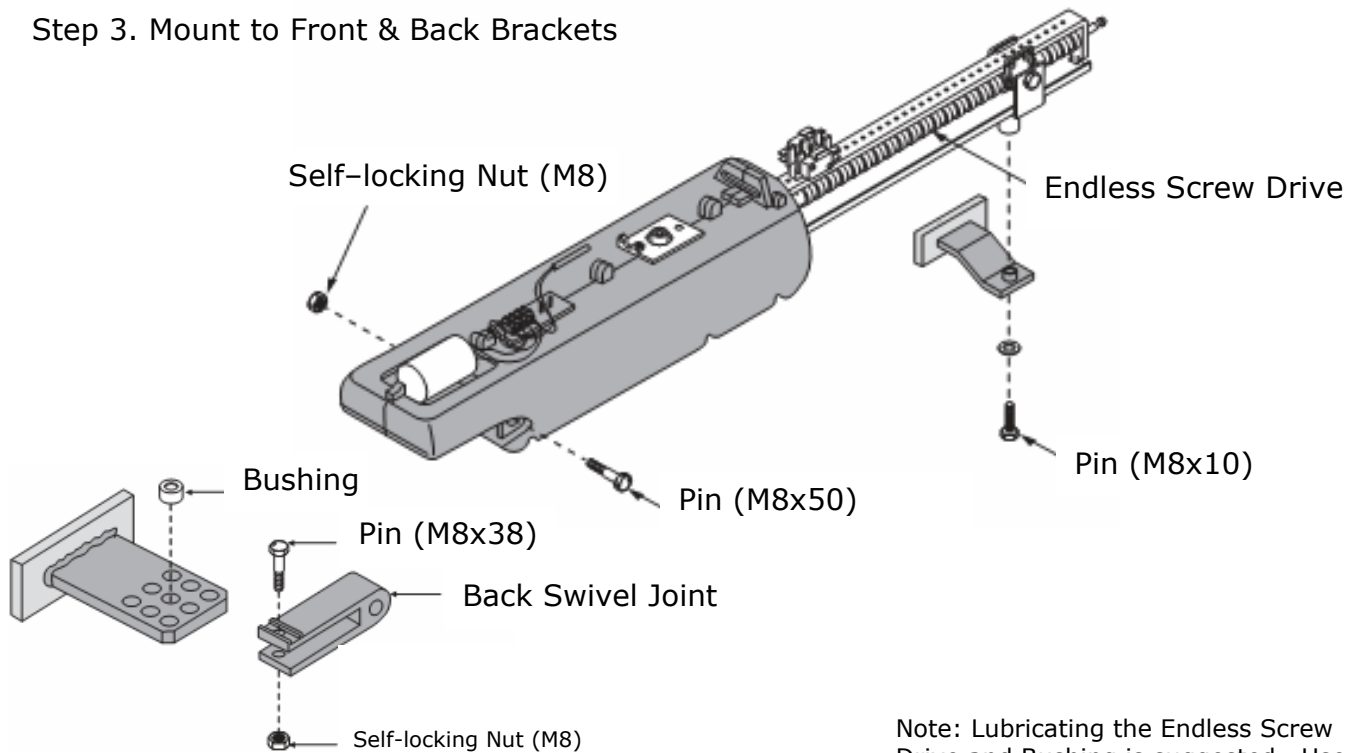

Note: Lubricating the Endless Screw Drive and Bushing is suggested. Use neutral grease.

INSTALLATION

ADJUSTING OPEN & CLOSED LIMIT

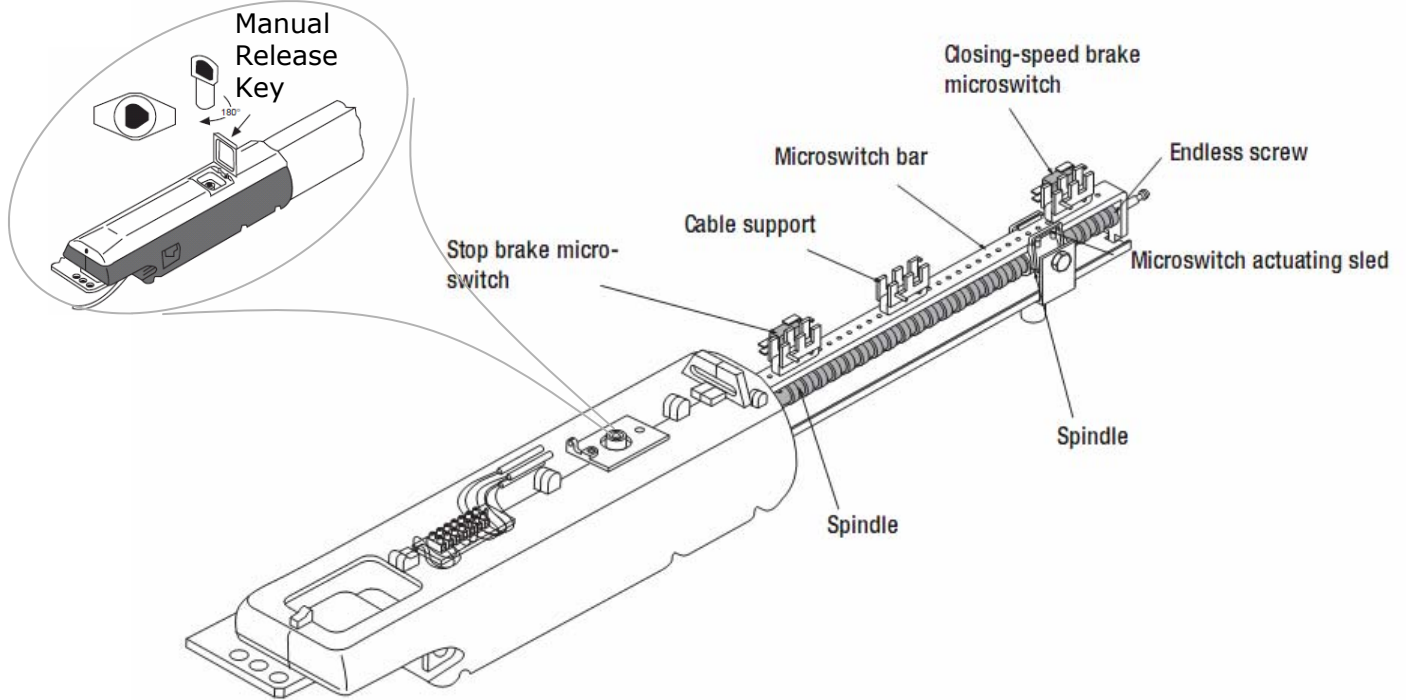

OPEN LIMIT

Using the Manual Release Key, release the gearmotor and swing the gate-leaf to the fully open position.

Loosen the Open Limit Micro-switch Assembly. Slide the Micro-switch Assembly along the Micro-switch Bar until it is inserted by contact on the Micro-switch Activating Sled.

Tighten the Micro-switch Assembly using the respective screws.

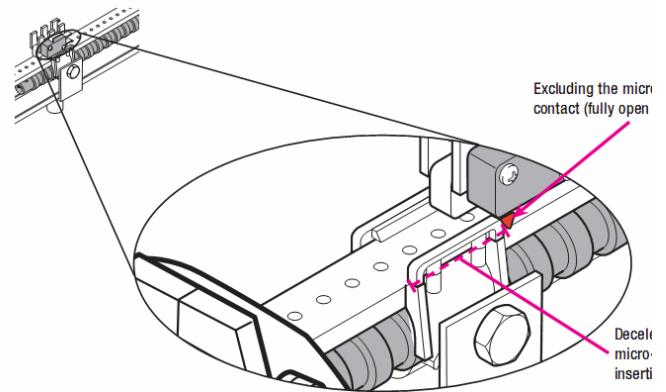

CLOSE LIMIT

Using the Manual Release Key, release the gearmotor and swing the gate-leaf to the fully closed position.

Loosen the Closed Limit Micro-switch Assembly.

Slide the Micro-switch Assembly along the Micro-switch Bar until it is inserted by contact on the Micro-switch Activating Sled.

Tighten the Micro-switch Assembly using the respective screws.

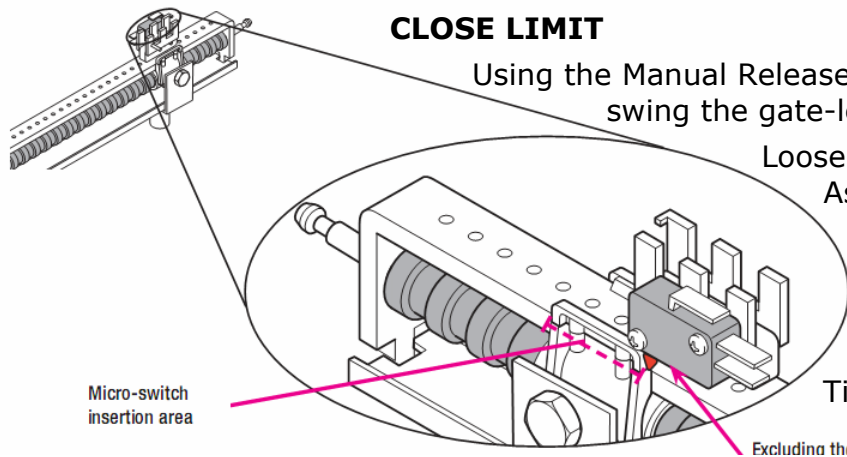

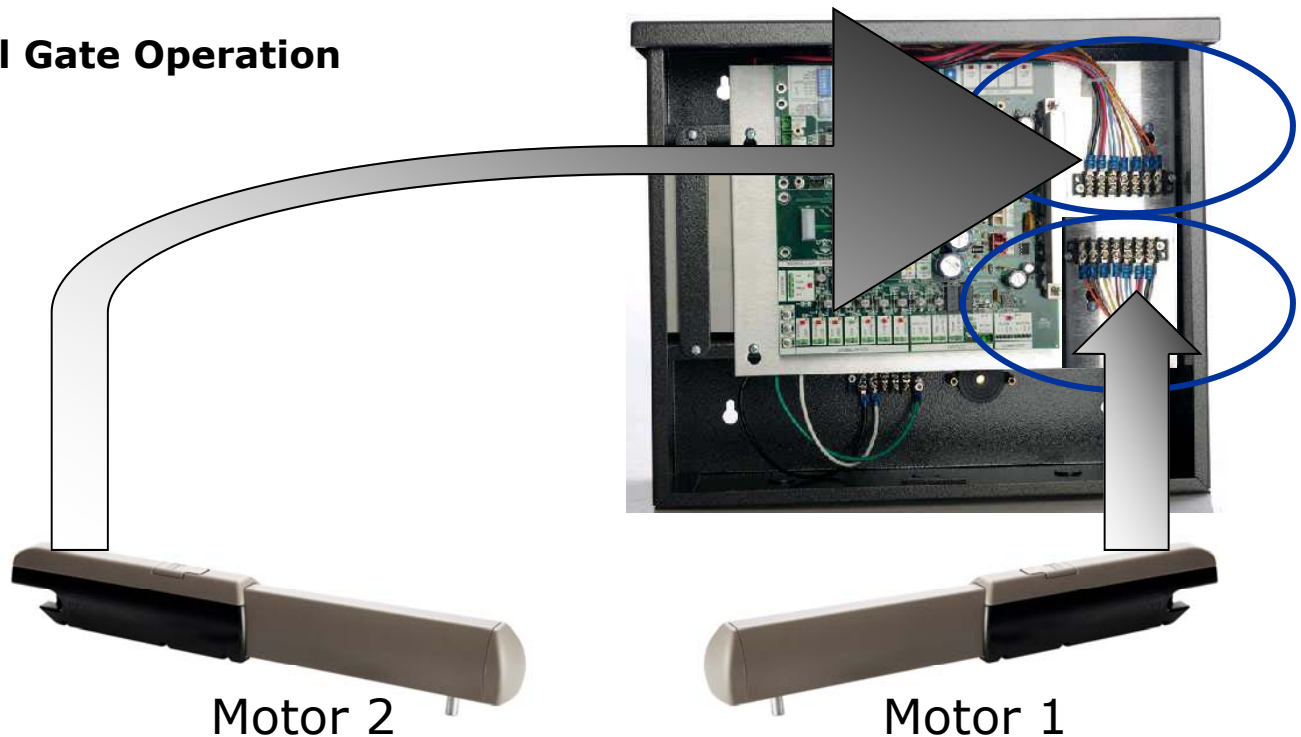
INSTALLATION**WIRING THE OPERATOR ARM****Dual Gate Operation**

The Eagle-E7 electro-mechanical swing arm includes color coded wire for convenient connection to the Diamond-DC Controller. On dual gate application, the electro-mechanical farthest from the control is generally considered Motor 2 and has 14' of control wire. The arm closest to the controller is designated Motor 1 and has 8' of control wire.

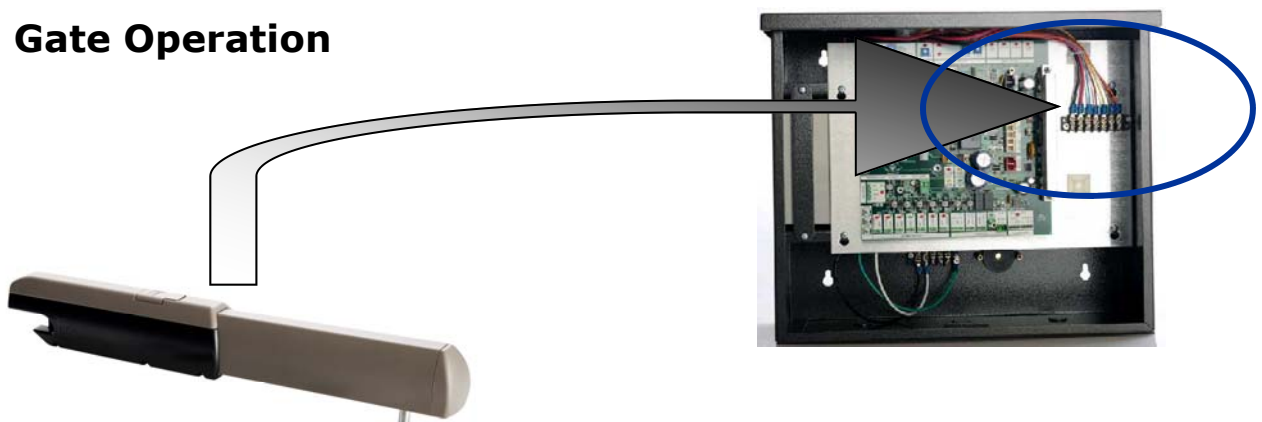
Single Gate Operation

INSTALLATION

AUTO POWER SAVE MODE—AUXILIARY POWER

Two 24 VDC auxiliary outputs are available for powering accessories.

Auxiliary Output 1—Use Auxiliary Output 1 for Auto Power Save mode. Auto Power Save mode maximizes battery back-up operation and conserves power in a solar Only application.



When AC power is not present (during power failure or solar only application), The Diamond-DC control board remains active for 30 seconds. After 30 seconds the Diamond-DC control board automatically goes to “sleep” to conserve power.

Conserving power in Auto Power Save Mode maximizes battery back-up operation and improves re-charging rate on solar only application.

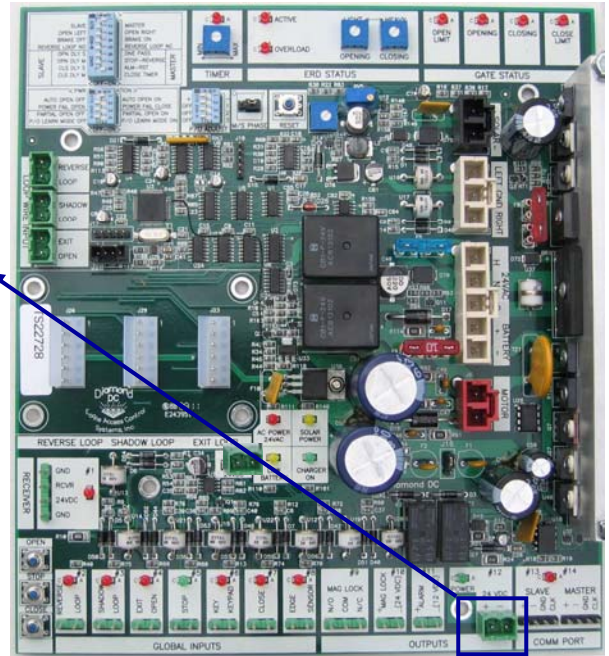

Note on Auto Power Save Mode: Output power remains always on to the pre wired terminal strip for the Receiver and to the Plug-in Loop Detector for Exit Open.

SOLAR READY For solar-only application and to maximize battery back-up cycles during power failure, connect accessories like the photo-eye detector to Auxiliary Power Output 1. In this way, the amp draw will be minimized during periods (overnight) when the gate operator is not in use.

Auxiliary Output 2—Use Auxiliary Output 2 for accessories that must remain always on.

Auxiliary Output 2 is “Always On,” even during Auto Power Save mode.



The current draw from Auxiliary Output 2 will remain constant and will continuously draw stored power from batteries during AC power Failure and a solar only application.

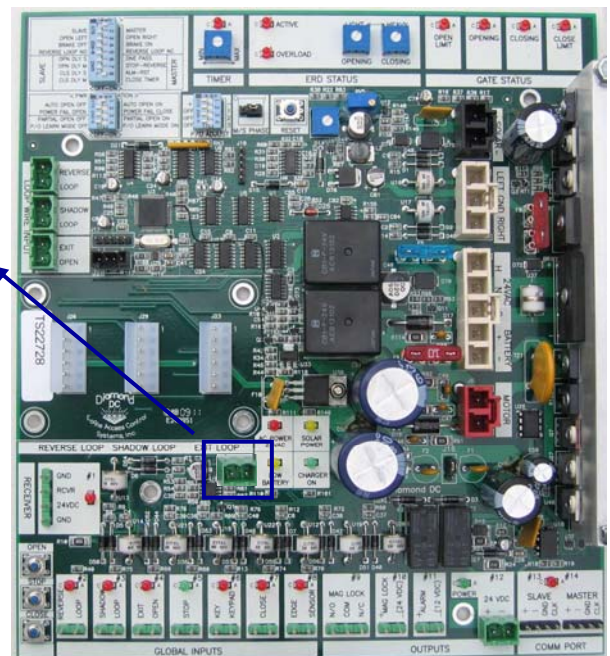

Note: Some devices, like keypads, card readers and telephone entry require their own, isolated power transformer. Eagle recommends putting such devices on separate e power transformer as direct by the manufacturer.

INSTALLATION

LOOP DETECTORS

STEP 1. Using Removable Connector, Connect wire (twisted pair) from each in-ground loop as indicated.

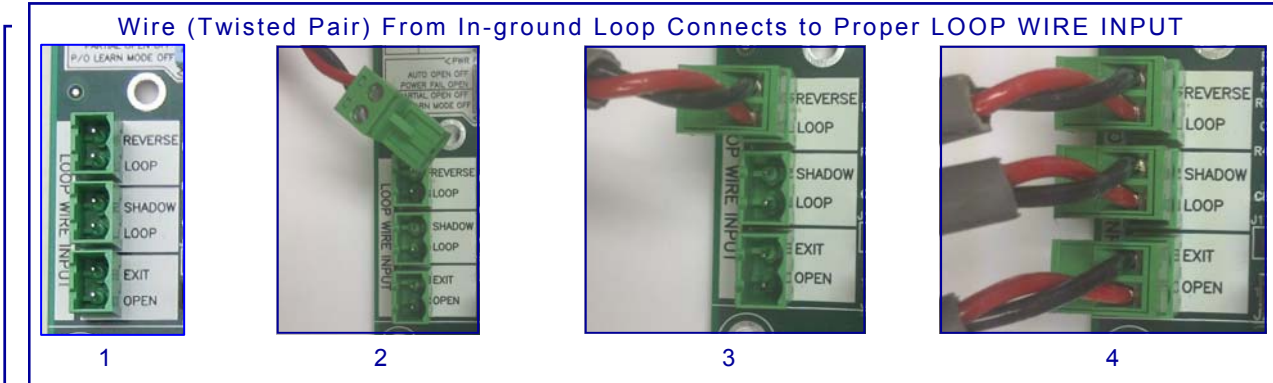

STEP 2. Plug in Eagle Loop Detector to Corresponding In-ground Loop as indicated **(USE ONLY EAGLE BRAND PLUG-IN LOOP DETECTORS)**

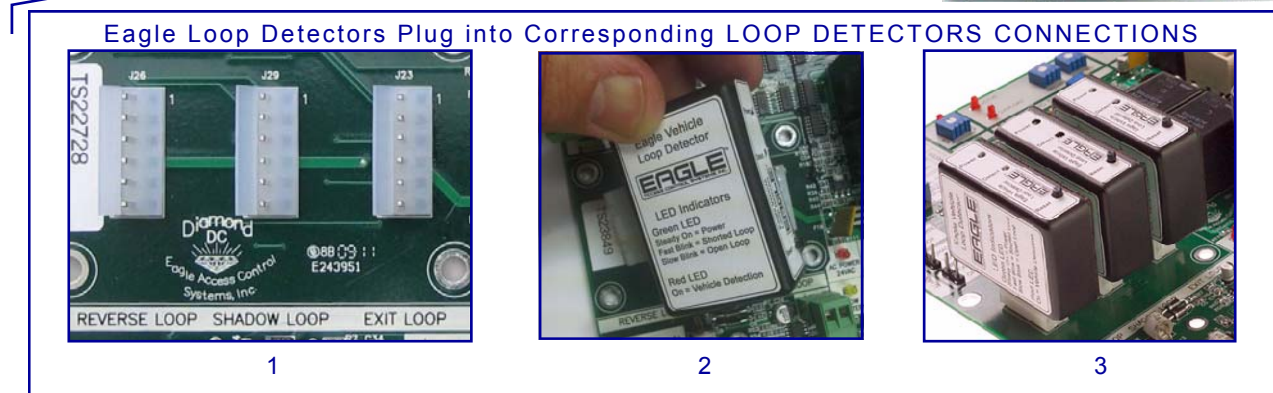
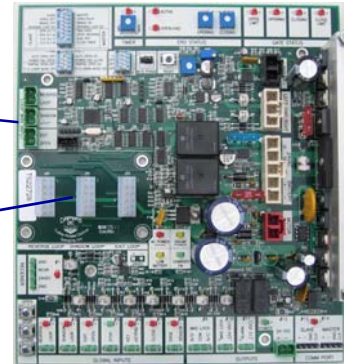

STEP 3. Eagle Loop Detectors automatically adjust for proper sensitivity.

Note: Eagle Brand Plug-in Loop Detectors are designed as "fail-Safe."

Eagle Vehicle Loop Detector

EAGLE

LED Indicators

Green LED
Steady On = Power
Fast Blink = Shorted Loop
Slow Blink = Open Loop

Red LED
On = Vehicle Detection

LED INDICATORS

Green LED (Upper LED)

- Steady On = Power
- Fast Blink = Shorted Loop Wire
- Slow Blink = Open Loop

Red LED (Lower LED)

- On = Vehicle Detection

INSTALLATION

POWER FAIL OPERATION

In the event of a power failure, your Eagle-DC Gate Operator will operate on battery back-up until AC power is restored or the batteries are completely discharged. Alternatively your Eagle-DC gate operator can be set up to "hold open" (fail-safe) or "hold closed" (fail-secure) until AC power is restored.

Following is the procedure for proper set-up of:

- BATTERY BACK-UP OPERATION
- AC Power Failure
 - HOLD-OPEN or HOLD_CLOSED During AC power failure
- COMPLETE BATTERY DISCHARGE

BATTERY BACK-UP OPERATION

When installed correctly, your Eagle-DC Gate Operator can provide up to 100 cycles of operation during an AC power Failure (Actual cycle count will vary based on your gate and site conditions). Consult your installing professional for estimated number of cycles for your gate system.

FOR BATTERY BACK-UP OPERATION

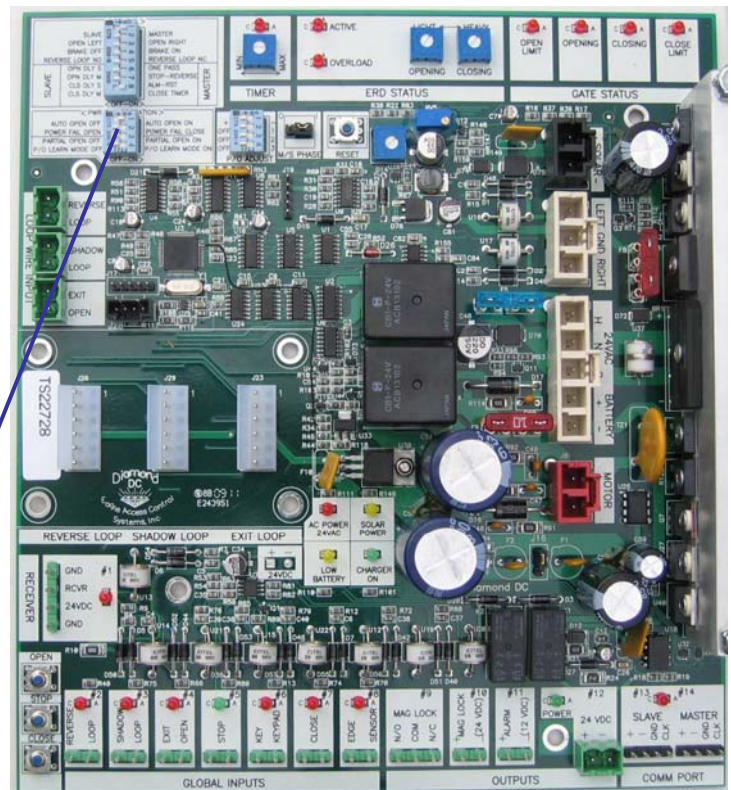
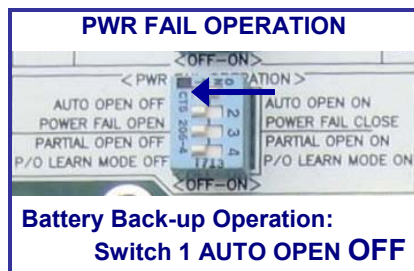

STEP 1. Find DIP Switch Panel Labeled "PWR FAIL OPERATION"

STEP 2. Turn Switch 1 to the OFF position

RESULT. When AC power fails, the gate will remain operational until AC power is restored or battery voltage drains minimum (see page 17).



INSTALLATION

POWER FAIL OPERATION (CONTINUED)

COMPLETE BATTERY DISCHARGE

To protect battery life, the Eagle-DC Gate Operator automatically shuts down when battery voltage drains to the minimum allowable for safe operation.

If shut down occurs due to lost battery voltage, select the Power Fail Operation to HOLD OPEN or HOLD CLOSED until AC power or battery voltage is restored.

HOLD OPEN During Complete Battery Discharge

STEP 1. Find DIP Switch Panel Labeled "PWR FAIL OPERATION"

STEP 2. Turn Switch 1 to the OFF position for Battery Back-up Operation (page 15)

STEP 3. Turn Switch 2 to the OFF position

RESULT. During Battery Back-up Operation, if battery voltage drains to its minimum allowable level, the gate will move to the full open position and remain open until AC power restored or battery voltage returns to normal.

HOLD CLOSED During Complete Battery Discharge

STEP 1. Find DIP Switch Panel Labeled "PWR FAIL OPERATION"

STEP 2. Turn Switch 1 to the OFF position for Battery Back-up Operation (page 15)

STEP 3. Turn Switch 2 to the ON position

RESULT. During Battery Back-up Operation, if battery voltage drains to its minimum allowable level, the gate will move to full closed position and remain closed until AC power is restored or battery voltage returns to normal.

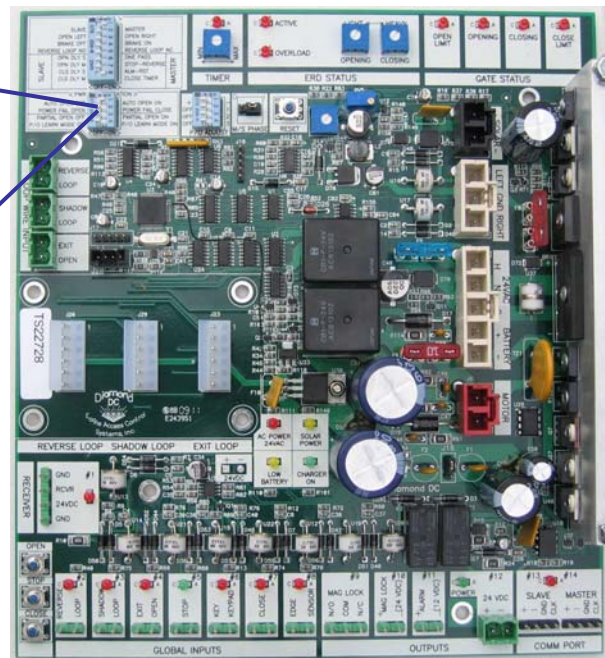
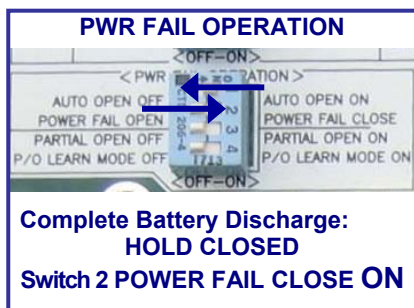
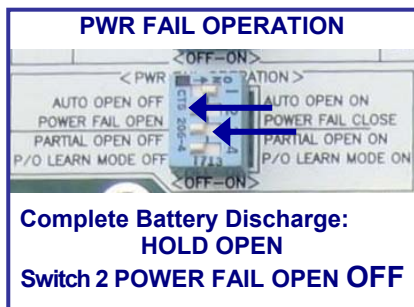

INSTALLATION

POWER FAIL OPERATION (CONTINUED)

HOLD-OPEN / HOLD-CLOSED During AC Power Failure

If you do not want to use Battery Back-up Operation during an AC Power Failure, you can choose to HOLD-OPEN (fail-safe) or HOLD-CLOSED (fail-secure) your gate until the AC Power is restored.

HOLD-OPEN During AC Power Failure

- STEP 1.** Find DIP Switch Panel Labeled "PWR FAIL OPERATION"
- STEP 2.** Turn Switch 1 to the ON position
- STEP 3.** Turn Switch 2 to the OFF position

RESULT. When AC power fails, the gate will move to the full open position and remain open until AC power is restored.

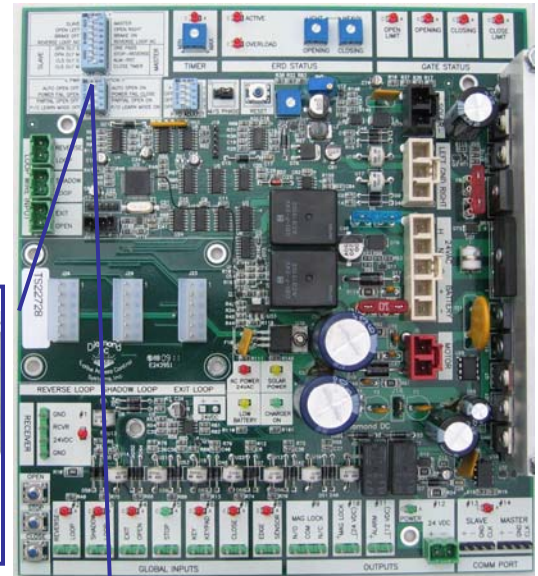
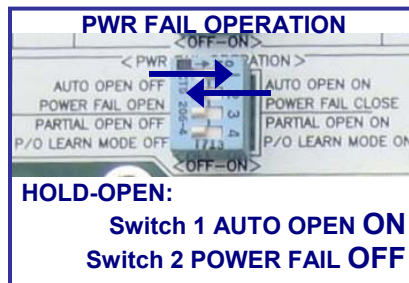

HOLD-CLOSED During AC Power Failure

- STEP 1.** Find DIP Switch Panel Labeled "PWR FAIL OPERATION"
- STEP 2.** Turn Switch 1 to the ON position
- STEP 3.** Turn Switch 2 to the ON position

RESULT. When AC power fails, the gate will move to the full closed position and remain open until AC power is restored.

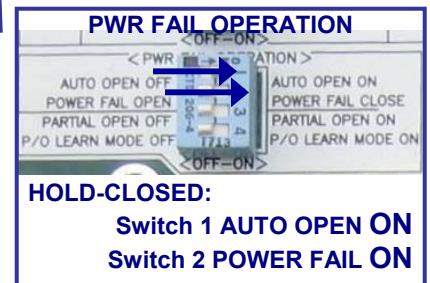

SET-UP & OPERATION

FEATURE SELECTOR

Feature Selector Switches

1. Master / Slave (Not Applicable/Do Not Use)
2. Opening Direction
3. Motor Brake (Not Applicable/Do Not Use)
4. Reverse Loop Input can be set to NO or NC MASTER
5. One Pass is an anti-tailgating feature
6. Stop Reverse is a convenience feature that allows your radio controls to work like a 3-button station; click to open, click to stop, click to close
7. Alarm Reset allows the operator to reset itself 5 minutes after going into overload
8. Close Timer



Feature Selector

Loop Wire Inputs

Reverse Loop for Use with Plug-in Loop Detector
 Shadow Loop for Use with Plug-in Loop Detector
 Exit Open for Use with Plug-in Loop Detector

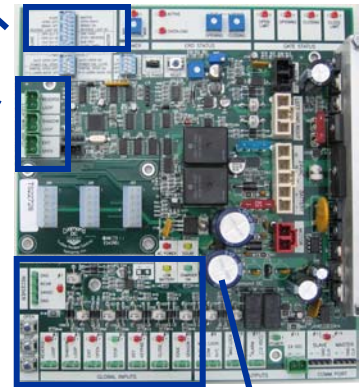
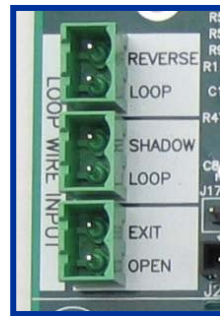

Inputs

- #1—Pre-wired Receiver Terminal Strip (3 and 4 wire receiver)
- #2—Reverse Loop for External Safety Loop Detector & Photo-eye
- #3—Phantom Loop for Phantom or External Shadow Loop Detector
- #4—Exit Loop for Exit Probe or External Loop Detector
- #5—Stop for NC Stop Button or 3-Button Station
- #6—Keypad for NO Keypad, Keylock & Fire Boxes
- #7—Close for 3-Button Station
- #8—Edge Sensor for Edge Sensor Input

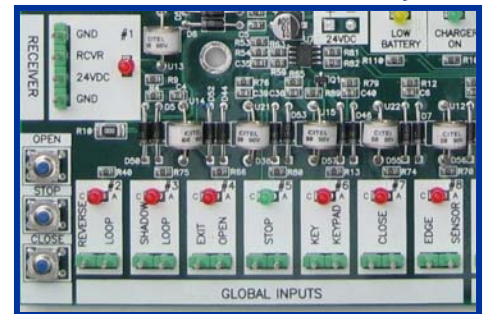

Outputs

- #9—Dry Contact Relay for NC or NO control of auxiliary device
- #10—Mag-Lock Relay for power and control of Magnetic Gate Lock
- #11—Alarm output for overload siren
- #12—24 VAC Power Output for accessories
- #13 & #14 Connection for 2-wire Master Slave Communication

Safety & Convenience

- Plug-in Loop Detectors & Loop Wire Connectors
- Open, Stop, Close controls on board
- ERD Adjustable in the Opening and Close Direction of travel



Eagle Access Control Systems, Inc.
13745 Saticoy Street
Van Nuys, CA 91402

Tel: 818-779-0920 * Fax: 818-779-0093 * Toll Free: 800-708-8848
www.EagleOperators.com