

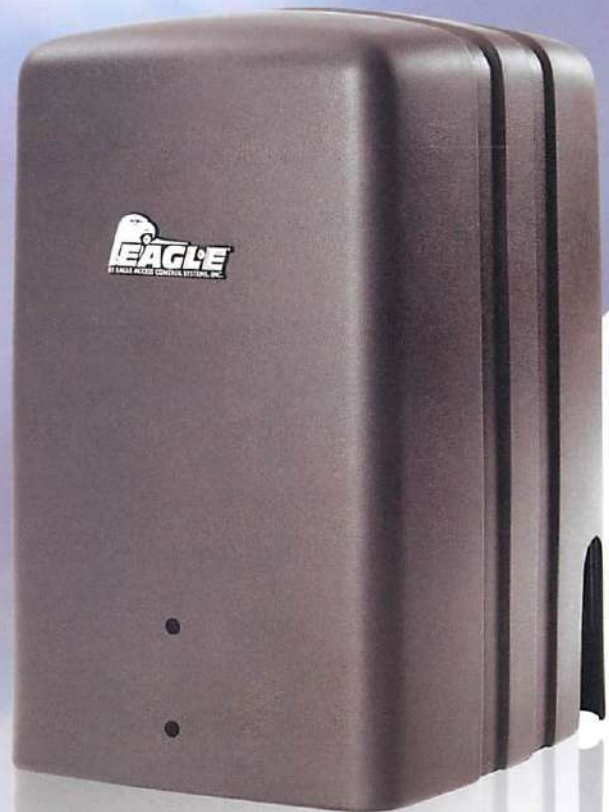

# EAGLE SLIDE GATE OPERATOR

## INSTALLATION & OWNERS MANUAL

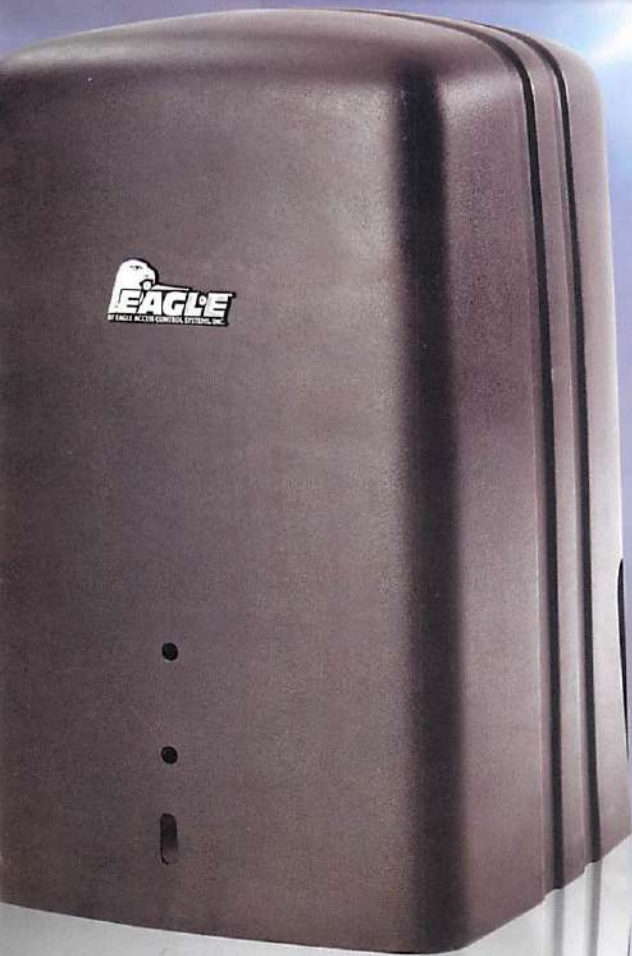

**EAGLE - 1000 SERIES**  
**EAGLE - 2000 SERIES**  
**EAGLE - 2000 - APT SERIES**

Made in USA



UL 325 Compliant / UL 991 Compliant



# TABLE OF CONTENTS

## UL Listings

Important Safety Information	3
Requirements for UL Compliant Installation	3
UL 325 Model Classifications	5
UL 325 Required Entrapment Protection	5

## General Safety

Warning Signs	6
No Pedestrian Crossing	6
Location of Controls	6
Never Ride Gate	6
Screen or Mesh	7
Gate Posts & Guide Rollers	7
Positive Stops	7
Entrapment Protection	8

## Gate Operator Overview

Eagle - 1000 Series	9
Eagle - 2000 Series	10
Eagle - 2000-APT Series	11

## Eagle Operator Installation

Electrical Requirement	12
Gate Operator Position	13
Mounting Gate Operator	13
Concrete Pad Preparation	14
Model Specific Mounting Template	15
Connecting the Chain	16

## Eagle Operator Set-up & Operation

Initial Set-up	18
<ul style="list-style-type: none"> <li>• Single or Dual Gate Systems (pg 18)</li> <li>• Direction of Travel (pg 18)</li> </ul>	<ul style="list-style-type: none"> <li>• Limit of Travel (pg 19)</li> <li>• Emergency Reversing Device (pg 19)</li> </ul>
Supplemental Feature Selection	20
<ul style="list-style-type: none"> <li>• Motor Brake for Heavy Gates (pg 20)</li> <li>• Selectable Reverse Loop (NO or NC) (pg 20)</li> <li>• One -Pass for Anti -tailgating (pg 20)</li> </ul>	<ul style="list-style-type: none"> <li>• Stop -Reverse for Convenience (pg 20)</li> <li>• Alarm Reset (pg 20)</li> <li>• Automatic Close Timer (pg 20)</li> </ul>
Primary & Secondary (M / S) Operation	21
<ul style="list-style-type: none"> <li>• Initial Set -up (pg 21)</li> <li>• Primary or Secondary (M / S) Selection (pg 21)</li> </ul>	<ul style="list-style-type: none"> <li>• Communication Port Connection (pg 21)</li> </ul>
Feature Selection: Primary (Master) Operator	
<ul style="list-style-type: none"> <li>• One -Pass for Anti -tailgating (pg 22)</li> <li>• Stop -Reverse for Convenience (pg 22)</li> </ul>	<ul style="list-style-type: none"> <li>• Alarm Reset (pg 22)</li> <li>• Automatic Close Timer (pg 22)</li> </ul>
Feature Selection: Secondary (Slave) Operator	
<ul style="list-style-type: none"> <li>• Switches 5 - 8 for Open &amp; Close Delay (pg 22)</li> </ul>	

## Accessories

<ul style="list-style-type: none"> <li>• Receiver (Radio Controls) Connection (pg 23)</li> <li>• Photo-eye Detector / Non-contact Sensor (pg 23)</li> <li>• In-ground Loops &amp; Loop Detectors (pg 24)</li> <li>• Edge Sensor Entrapment Protection (pg 25)</li> <li>• 3 -Button Station (pg 26)</li> </ul>	<ul style="list-style-type: none"> <li>• Fire and Key Lock Boxes (pg 26)</li> <li>• Keypads, Proximity Readers &amp; Telephone Entry (pg 27)</li> <li>• Magnetic Lock (pg 27)</li> <li>• Dry Contact Relay (Additional Accessories) (pg 27)</li> </ul>
---	--

## Operator Parts

	28
--	----

## Installation Check List, Care & Maintenance

<ul style="list-style-type: none"> <li>• Power Fail operation</li> <li>• Resetting Motor</li> </ul>	<ul style="list-style-type: none"> <li>• Replacing Remote Controls</li> </ul>	30
---	---	----





## UL LISTINGS

### IMPORTANT SAFETY INFORMATION

#### **⚠ WARNING**

**To reduce the risk of INJURY or DEATH read and follow the instructions**

1. Never let children operate or play with gate controls. Keep the remote control away from children.
2. Always keep people and objects away from the gate. **NO ONE SHOULD CROSS THE PATH OF THE MOVING GATE.**
3. Test the gate operator monthly. The gate **MUST** reverse on contact with a rigid object or stop when an object activates the non-contact sensors. After adjusting the force or the limit of travel, re-test the gate operator. Failure to adjust and re-test the gate operator properly can increase the risk of injury or death.
4. Use the emergency release only when the gate is not moving.
5. **KEEP GATES PROPERLY MAINTAINED.** Read the owner's manual. Have a qualified service person make repairs to gate hardware.
6. The entrance is for vehicles only. Pedestrians must use separate entrance.
7. **SAVE THESE INSTRUCTIONS.**

### REQUIREMENTS FOR UL COMPLIANT INSTALLATION

1. Install the gate operator only when:
  - a) The operator is appropriate for the construction of the gate and the usage class of the gate.
  - b) All openings of a horizontal slide gate are guarded or screened from the bottom of the gate to a minimum of 4 feet (1.22 m) above the ground to prevent a 2-1/4 inch (57.2 mm) diameter sphere from passing through the openings anywhere in the gate, and in that portion of the adjacent fence that the gate covers in the open position.
  - c) All exposed pinch points are eliminated or guarded, and
  - d) Guarding is supplied for exposed rollers.
2. The operator is intended for installation only on gates used for vehicles. Pedestrians must be supplied with a separate access opening. The pedestrian access opening shall be designed to promote pedestrian usage. Locate the pedestrian gate such that persons will not come in contact with the vehicular gate during the entire path of travel of the vehicular gate.
3. The gate must be installed in a location so that enough clearance is supplied between the gate and adjacent structures when opening and closing to reduce the risk of entrapment. Swinging gates shall not open into public access areas.
4. The gate must be properly installed and work freely in both directions prior to the installation of the gate operator. Do not over-tighten the operator clutch or pressure relief valve to compensate for a damaged gate.

### REQUIREMENTS FOR UL COMPLIANT INSTALLATION (continued)

5. For gate operators utilizing Type D protection:
  - a) The gate operator controls must be placed so that the user has full view of the gate area when the gate is not moving.
  - b) The placard provided marked in letters at least 1/4 in. (6.4-mm) high with the word "WARNING" and the following statement or the equivalent: "Moving Gate Has the Potential of Inflicting Injury or Death - Do Not Start Gate Unless Path is Clear" shall be placed adjacent to the controls.
  - c) An automatic closing device (such as a timer, loop sensor, or similar device) shall not be employed, and
  - d) No other activation device shall be connected.
6. Controls intended for user activation must be located at least six feet (6') away from any moving part of the gate and where the user is prevented from reaching over, under, around or through the gate to operate the controls. Outdoor or easily accessible controls shall have a security feature to prevent unauthorized use.
7. The Stop and /or Reset button must be located in the line-of-sight of the gate. Activation of the reset control shall not cause the operator to start.
8. A minimum of two (2) WARNING SIGNS shall be installed, one on each side of the gate where easily visible.
9. For gate operators utilizing a non-contact sensor in accordance with Usage Class:
  - a) See instructions on the placement of non-contact sensors for each type of application,
  - b) Care shall be exercised to reduce the risk of nuisance tripping, such as when a vehicle trips the sensor while the gate is still moving, and
  - c) One or more non-contact sensors shall be located where the risk of entrapment or obstruction exists, such as the perimeter reachable by a moving gate or barrier.
10. For gate operators utilizing a contact sensor in accordance with Usage Class:
  - a) One or more contact sensors shall be located where the risk of entrapment or obstruction exists, such as at the leading edge, trailing edge, and post-mounted both inside and outside of a vehicular horizontal slide gate.
  - b) One or more contact sensors shall be located at the bottom edge of a vehicular vertical lift gate.
  - c) One or more contact sensors shall be located at the pinch point of a vehicular vertical pivot gate.
  - d) A hardwired contact sensor shall be located and its wiring arranged so that the communication between the sensor and the gate operator is not subjected to mechanical damage.
  - e) A wireless contact sensor such as one that transmits radio frequency (RF) signals to the gate operator for entrapment protection functions shall be located where the transmission of the signals are not obstructed or impeded by building structures, natural landscaping or similar obstruction. A wireless contact sensor shall function under the intended end-use conditions.
  - f) One or more contact sensors shall be located on the inside and outside leading edge of a swing gate. Additionally, if the bottom edge of a swing gate is greater than 6 inches (152 mm) above the ground at any point in its arc of travel, one or more contact sensors shall be located on the bottom edge.
  - g) One or more contact sensors shall be located at the bottom edge of a vertical barrier (arm).



# UL LISTINGS

## UL 325 MODEL CLASSIFICATIONS

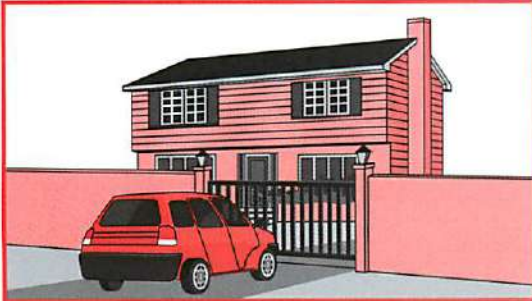

**Class I (Residential Vehicular Gate Operator)** - A vehicular gate operator (opener or system) intended for use in a home of one to four single family dwellings, or a garage or parking area associated therewith.

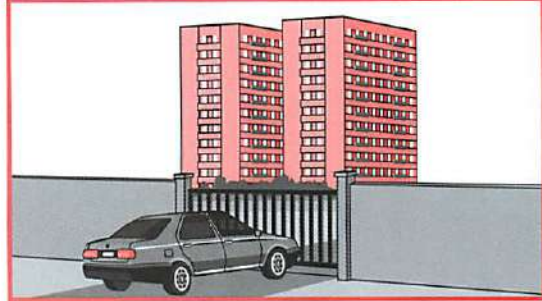

**Class II (Commercial/General Access Vehicular Gate Operator)** - A vehicular gate operator (opener or system) intended for use in a commercial location or building such as a multi-family housing unit (five or more single family units), hotel, garages, retail store, or other buildings servicing the general public.

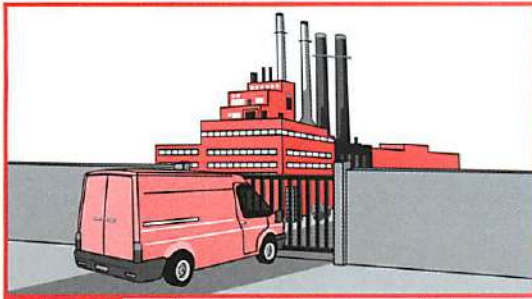

**Class III (Industrial/Limited Access Vehicular Gate Operator)** - A vehicular gate operator (opener or system) intended for use in an industrial location, loading dock area, or other location not intended to service the general public.

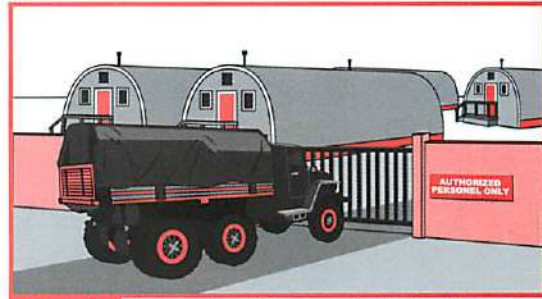

**Class IV (Restricted Access Vehicular Gate Operator)** - A vehicular gate operator (opener or system) intended for use in a guarded industrial location or buildings such as airport security area or other restricted access locations not servicing the general public, in which unauthorized access is prevented via supervision by security personnel.

## UL 325 REQUIRED ENTRAPMENT PROTECTION

### Entrapment Protection Requirements For Each UL 325 Classification

Proper installation must satisfy the entrapment protection chart as shown. The installation must have one **PRIMARY** means and one **SECONDARY** means of entrapment protection in both the **OPEN** and **CLOSE** direction of gate travel.

- A - Inherent (built into the gate operator) Entrapment Protection System, and at least one of the following as indicated on chart
- B1 - Non-contact Sensor such as photo-eye or equivalent
- B2 - Contact Sensor such as edge sensor or equivalent

- C - Inherent Adjustable Clutch or Pressure Relief Device
- D - Actuating Device requiring continuous pressure to maintain gate motion
- E - Inherent Audio Alarm

GATE TYPE	PROTECTION	CLASS I & II	CLASS III	CLASS IV
HORIZONTAL SLIDE, VERTICAL LIFT, VERTICAL PIVOT GATE	Primary Type	A	A, B1, B2	A, B1, B2, D
	Secondary Type	B1, B2, D	A, B1, B2, D, E	A, B1, B2, D, E
SWING GATE OR VERTICAL BARRIER (ARM)	Primary Type	A, C	A, B1, B2, C	A, B1, B2, C, D
	Secondary Type	A, B1, B2, C, D	A, B1, B2, D, E	A, B1, B2, C, D, E



## GENERAL SAFETY

### ⚠ WARNING

WARNING SIGNS to be placed adjacent to controls and on both sides of gate.

### ⚠ WARNING



#### Moving Gate Can Cause Serious Injury or Death

KEEP CLEAR! Gate may move at any time without prior warning.  
Do not let children operate the gate or play in the gate area.  
This entrance is for vehicles only. Pedestrians must use separate entrance.

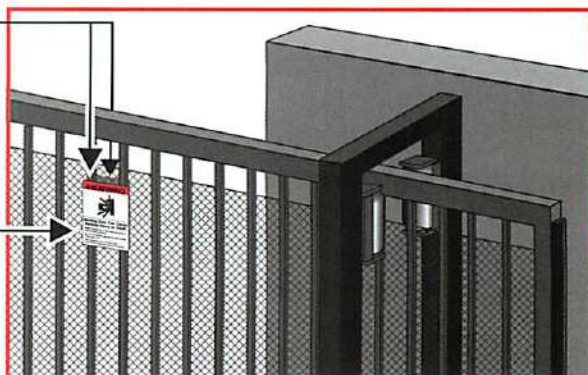

### ⚠ WARNING

DO NOT let pedestrians cross the path of a moving gate!

### ⚠ WARNING

DO NOT mount any gate operating controls near the gate's path!

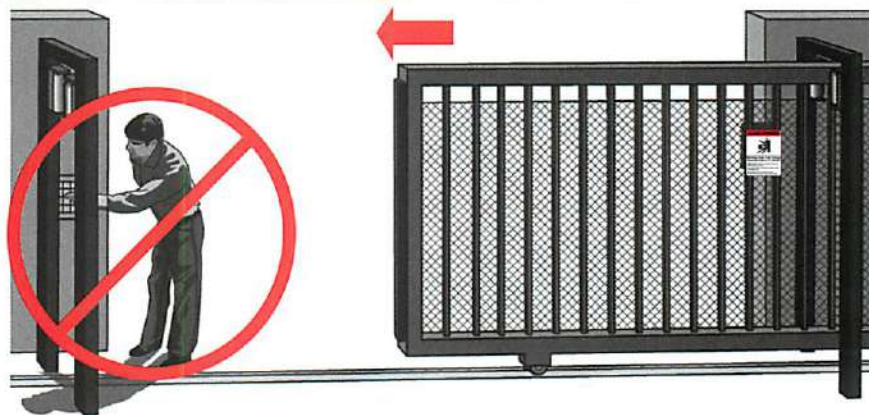

### ⚠ WARNING

DO NOT allow anyone to hang or ride on the gate!



# GENERAL SAFETY

## SCREEN OR MESH

All openings of gate guarded or screened from the bottom of the gate to a minimum of 4 feet (1.22 m) above the ground to prevent a 2-1/4 inch (57.2 mm) diameter sphere from passing through the openings anywhere in the gate, and in that portion of the adjacent fence that the gate covers in the open position.

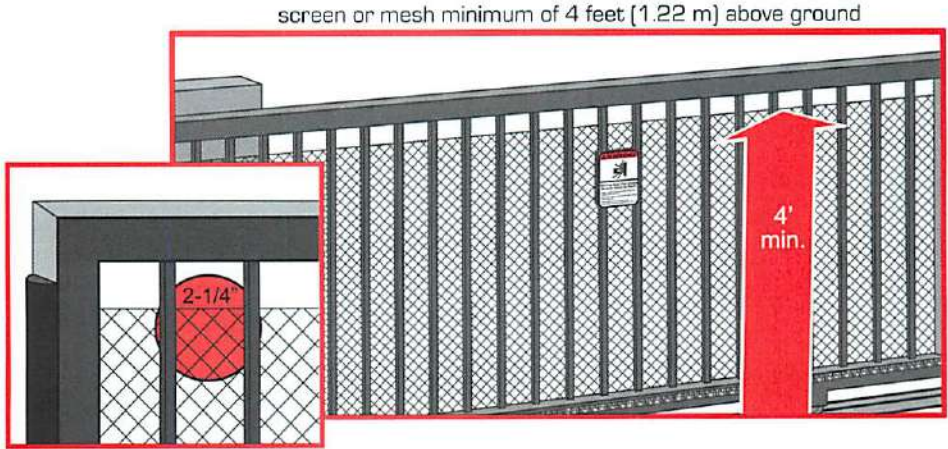

## GATE POSTS & GUIDE ROLLERS

Recommended

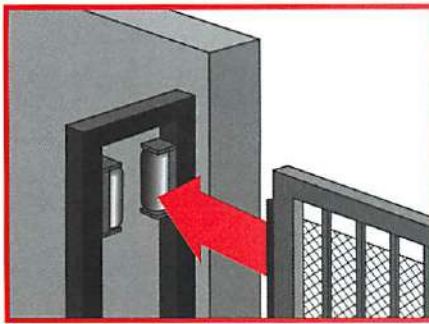

Not Recommended

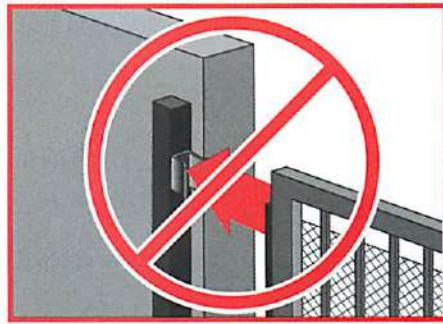

Install **ONLY** catch rollers with safety covers on the side of a post or wall.

## POSITIVE STOPS

A positive stop **MUST BE INSTALLED** on the gate track prior to installation of the gate to assure that the gate does not exceed limit of travel and derail while opening or closing fully. When fully open, the end of the sliding gate must stop at least 3" (three inches) from any wall or other objects.

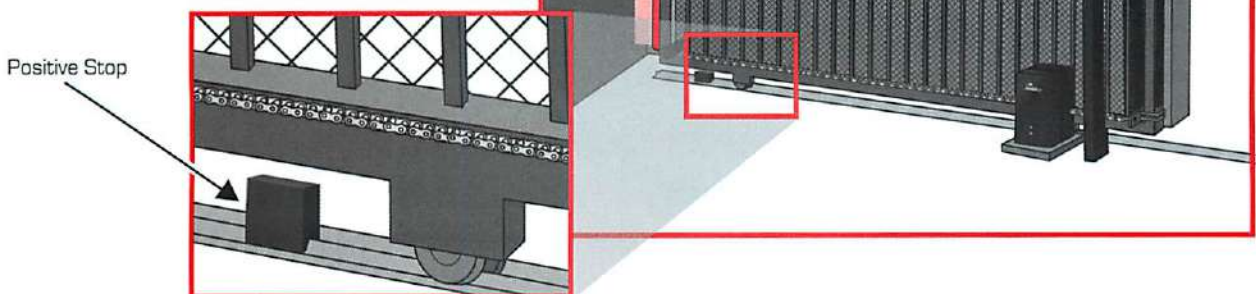

# GENERAL SAFETY

## ENTRAPMENT PROTECTION

### ⚠ WARNING

To prevent SERIOUS INJURY or DEATH from a moving gate:

- Entrapment protection devices **MUST** be installed to protect anyone who may come near a moving gate.
- Locate entrapment protection devices to protect in **BOTH** the open and close gate cycles.
- Locate entrapment protection devices to protect between moving gate and **RIGID** objects, such as posts or walls.
- Refer to chart of UL 325 required entrapment protection (pg. 5) for proper safety devices for your gate classification.

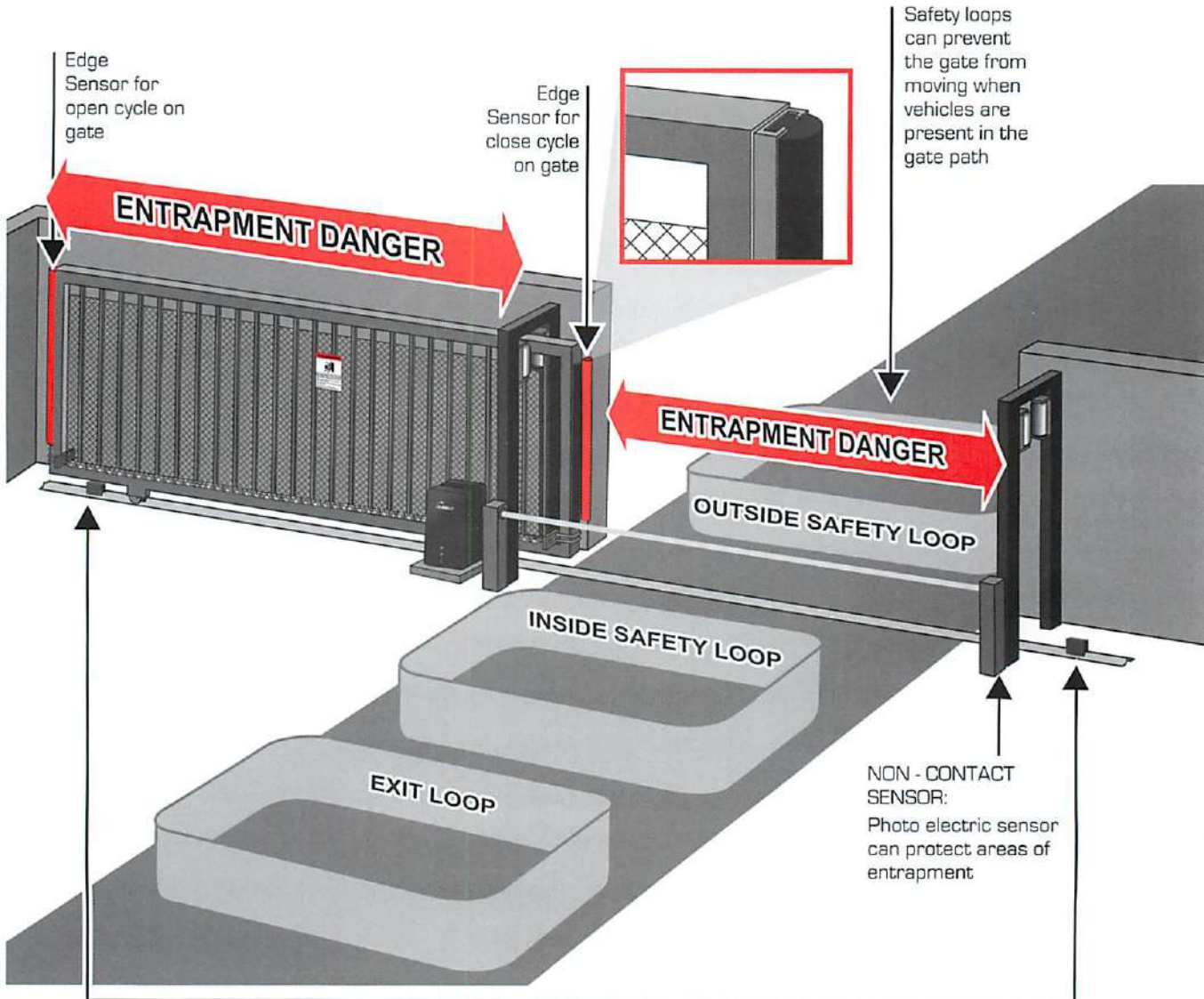

**POSITIVE STOPS:** A positive stop **MUST BE INSTALLED** to assure that the gate does not exceed limit of travel and derail while opening or closing fully.



# GATE OPERATOR OVERVIEW



## TERMS, WEIGHT & DIMENSIONS

**Fail-Safe (FSF)** – When the power supply fails, a Fail-Safe gate operator automatically switches to manual operation. Without power, your gate can be operated manually while still connected to the Fail-Safe Eagle Gate Operator.

**Fail-Secure (FSC)** – When the power supply fails, a Fail-Secure gate operator cannot be “pushed” open or closed. Fail-Secure gate operators require a hand crank (included) to be manually moved.

**Dual-Motor (DM)** – Dual Motor gate operators utilize two motors and are well suited for high traffic applications. One motor (Motor A) opens the gate while Motor B remains at rest. One motor (Motor B) closes the gate while Motor A remains at rest. All dual motor (DM) operators are Fail-Secure (FSC).

**Twin-Motor (1HP & 1.5HP)** – Heavy duty applications can require additional horse power. Eagle operators achieve increased horse power with twin motors, such as the Eagle - 2000 -1HP and the 2000 - APT -1.5HP, where both motors are synchronized and work together in the opening and closing direction. All dual motor (DM) operators are Fail-Secure (FSC).

Eagle-2000 Series Eagle-2000-APT Series	Eagle-1000 Series
	
<b>Shipping Weights</b>	
Eagle-1000 Series .....	105 lbs
Eagle-2000-FSF/FSC .....	135 lbs
Eagle-2000-1HP/DM .....	155 lbs
Eagle-2000-APT .....	160 lbs
Eagle-2000-APT-1HP/DM .....	185 lbs

## EAGLE - 1000 SERIES SLIDE GATE OPERATORS

Model: Eagle - 1000 - FSF  
Gate Capacity: 22 ft. & 500 lbs.  
Motor: One, 1/2 HP Continuous Duty/  
Instant Reversing  
Power: 115 VAC @ 60 HZ, 5.7 AMPS  
Power Fail Operation: Fail - Safe  
(push to open)

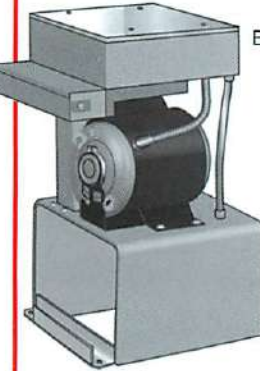

BACK



COVER

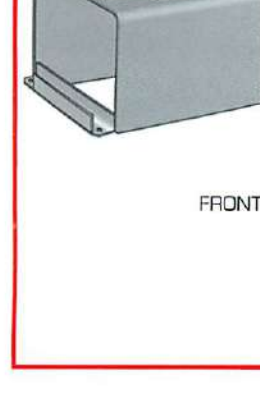

FRONT

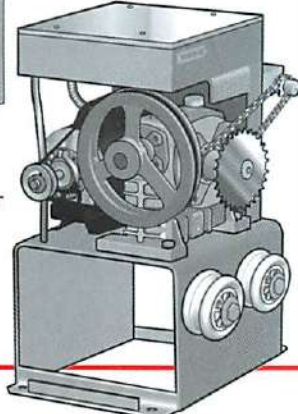

Model: Eagle - 1000 - FSC  
Gate Capacity: 22 ft. & 500 lbs.  
Motor: One, 1/2 HP Continuous Duty/  
Instant Reversing  
Power: 115 VAC @ 60 HZ, 5.7 AMPS  
Power Fail Operation: Fail - Secure  
(crank to open)

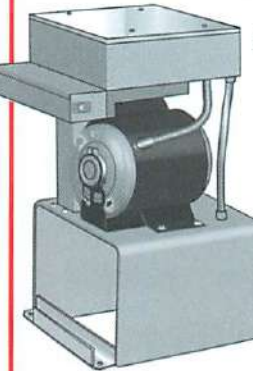

BACK



COVER

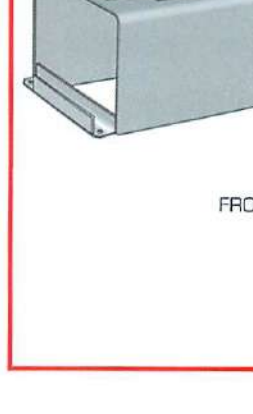

FRONT

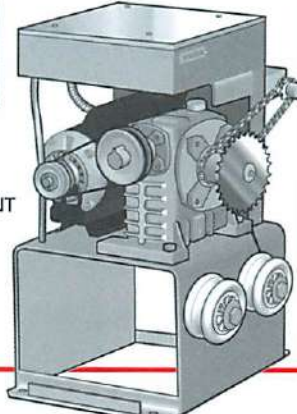



# GATE OPERATOR OVERVIEW

## EAGLE - 2000 SERIES SLIDE GATE OPERATORS

Model: Eagle - 2000 - FSF  
 Gate Capacity: 45 ft. & 1000 lbs.  
 Motor: One, 1/2 HP Continuous Duty/  
 Instant Reversing  
 Power: 115 VAC @ 60 HZ, 5.7 AMPS  
 Power Fail Operation: Fail - Safe  
 (push to open)

COVER

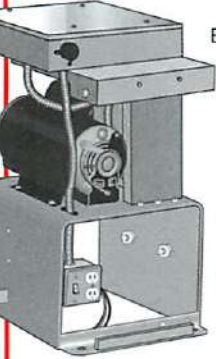

BACK

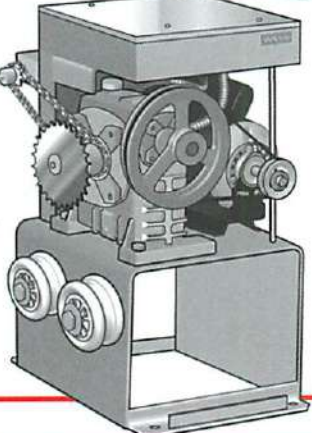

FRONT

Model: Eagle - 2000 - 1HP  
 Gate Capacity: 45 ft. & 2000 lbs.  
 Motor: Two, 1/2 HP Continuous Duty/  
 Instant Reversing  
 Power: 115 VAC @ 60 HZ, 11.4 AMPS  
 Power Fail Operation: Fail - Secure  
 (crank to open)

COVER

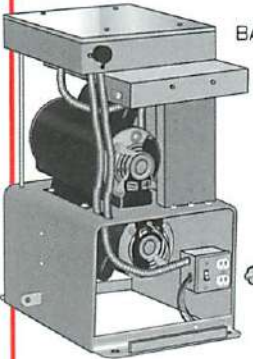

BACK

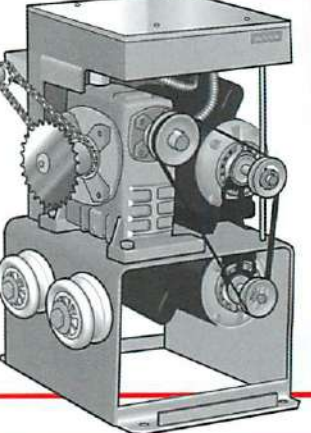

FRONT

Model: Eagle - 2000 - FSC  
 Gate Capacity: 45 ft. & 1000 lbs.  
 Motor: One, 1/2 HP Continuous Duty/  
 Instant Reversing  
 Power: 115 VAC @ 60 HZ, 5.7 AMPS  
 Power Fail Operation: Fail - Secure  
 (crank to open)

COVER

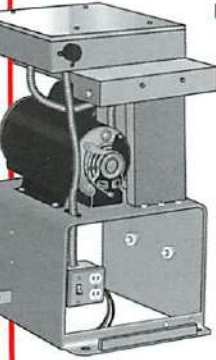

BACK

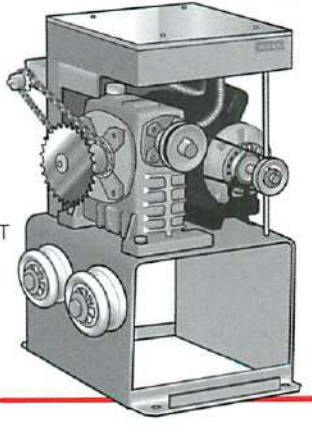

FRONT

Model: Eagle - 2000 - DM  
 Gate Capacity: 45 ft. & 1000 lbs.  
 Motor: Two, 1/2 HP Continuous Duty/  
 Instant Reversing  
 Power: 115 VAC @ 60 HZ, 11.4 AMPS  
 Power Fail Operation: Fail - Secure  
 (crank to open)

COVER

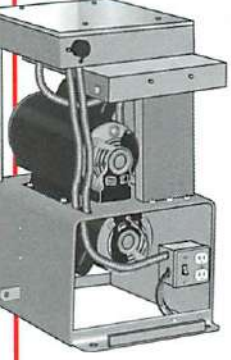

BACK

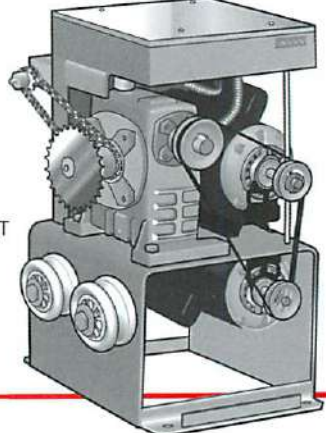

FRONT



# GATE OPERATOR OVERVIEW

## EAGLE - 2000 - APT SERIES SLIDE GATE OPERATORS

Model: Eagle - 2000 - APT  
Gate Capacity: 50 ft. & 2000 lbs.  
Motor: One, 1 HP Continuous Duty/  
Instant Reversing  
Power: 115 VAC @ 60 HZ, 10.5 AMPS  
Power Fail Operation: Fail - Secure  
(crank to open)

COVER

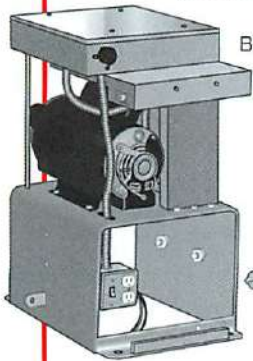

FRONT

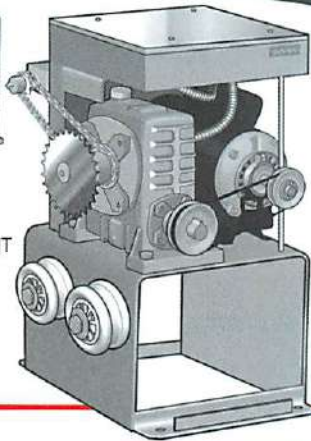

Model: Eagle - 2000 - APT - 1.5 HP  
Gate Capacity: 50 ft. & 2500 lbs.  
Motor: Two, 3/4 HP Continuous Duty/  
Instant Reversing  
Power: 115 VAC @ 60 HZ, 16.6 AMPS  
Power Fail Operation: Fail - Secure  
(crank to open)

COVER

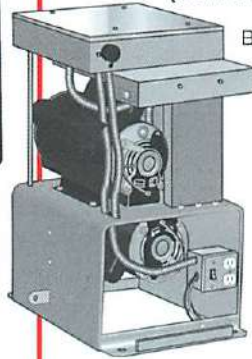

FRONT

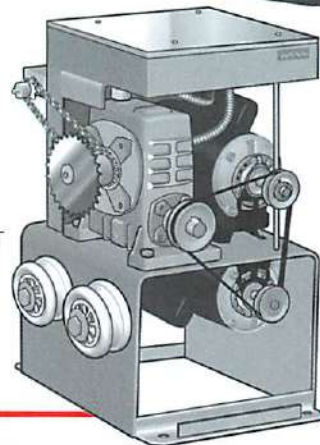

Model: Eagle 2000 - APT - DM  
Gate Capacity: 50 ft. & 2000 lbs.  
Motor: Two, 1 HP Continuous Duty/  
Instant Reversing  
Power: 115 VAC @ 60 HZ, 10.5 AMPS  
Power Fail Operation: Fail - Secure  
(crank to open)

COVER

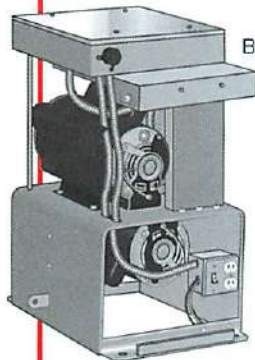

FRONT

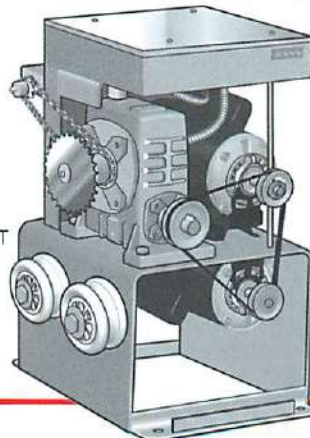

# EAGLE OPERATOR INSTALLATION

## ELECTRICAL REQUIREMENT

### ⚠ WARNING

- Electrical power **MUST** be disconnected and locked-out before ANY WORK to install, service, maintain or repair the operator. **DISCONNECT THE POWER AT THE CIRCUIT BREAKER.**
- Operator **MUST** be properly grounded and connected and all connections **MUST** be made by a qualified individual according to local code.
- All wiring should be made to a **DEDICATED** circuit and the location of the power disconnect should be visible and clearly labeled.
- **FOLLOW** all specifications herein. Failure to do so may cause severe injury to persons and/or damage to operator.

### WIRING CHART

GATE OPERATOR	14 AWG	12 AWG	10 AWG	8 AWG	4 AWG	DEDICATED FUSE
Eagle-1000 Series Eagle-2000-FSF Eagle-2000-FSC Eagle-2000-DM	200 ft.	400 ft.	650 ft.	1000 ft.	2000 ft.	15A
Eagle-2000-1HP Eagle-2000-APT Eagle-2000-APT-DM Eagle-2000-APT-1.5HP	100 ft.	200 ft.	325 ft.	500 ft.	1000 ft.	20A

### EARTH GROUND & IN-LINE SURGE SUPPRESSION

Check local code for proper depth.

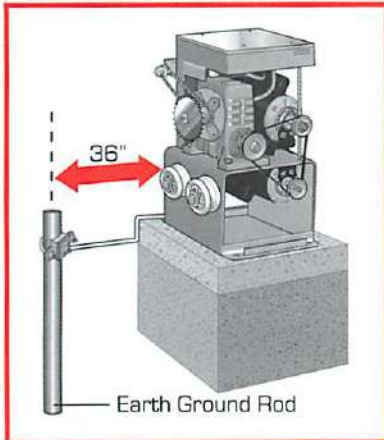

**ALWAYS CONTACT** local utility companies **BEFORE** digging.

- Proper earth grounding provides a path to discharge intense electrical static charge or near direct lightning strike safely into the earth.
- In-line surge suppression can stabilize fluctuation of in-coming power supply.

Nothing can absorb the power of a direct lightning strike, or extreme voltage spike from original power source, but proper earth grounding & surge suppression can protect the gate operator in most cases.

Each gate operator has a Dedicated 20 amp fuse.

### WIRING THE POWER

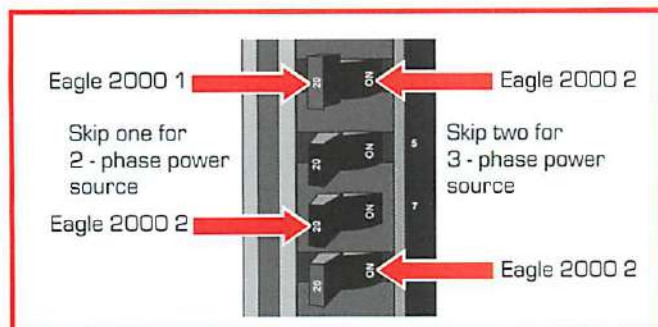

In-Line Surge Suppressor





# EAGLE OPERATOR INSTALLATION

## GATE OPERATOR POSITION

Front position

Rear position

Additional Idler Wheel or Sprocket Required  
(Eagle Part NO. E651 Idler Pulley Assembly Complete)

Eagle Part # E651



## MOUNTING GATE OPERATOR

To avoid premature wear, gate operator and chain must be parallel to gate,

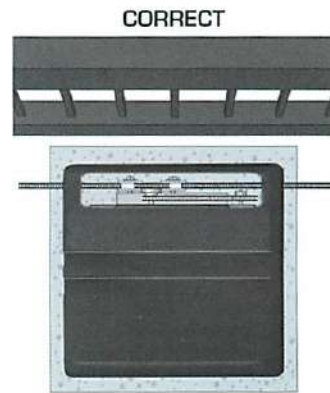

Chain must be level with idler wheel when gate is fully open and fully closed.

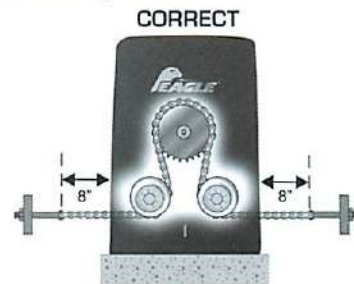

# EAGLE OPERATOR INSTALLATION

## CONCRETE PAD PREPARATION

### ⚠ WARNING

Consult local codes for actual requirements in your area. Your requirements will vary.

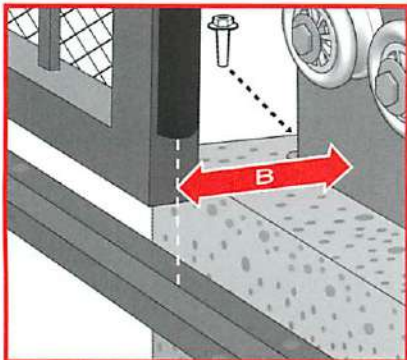
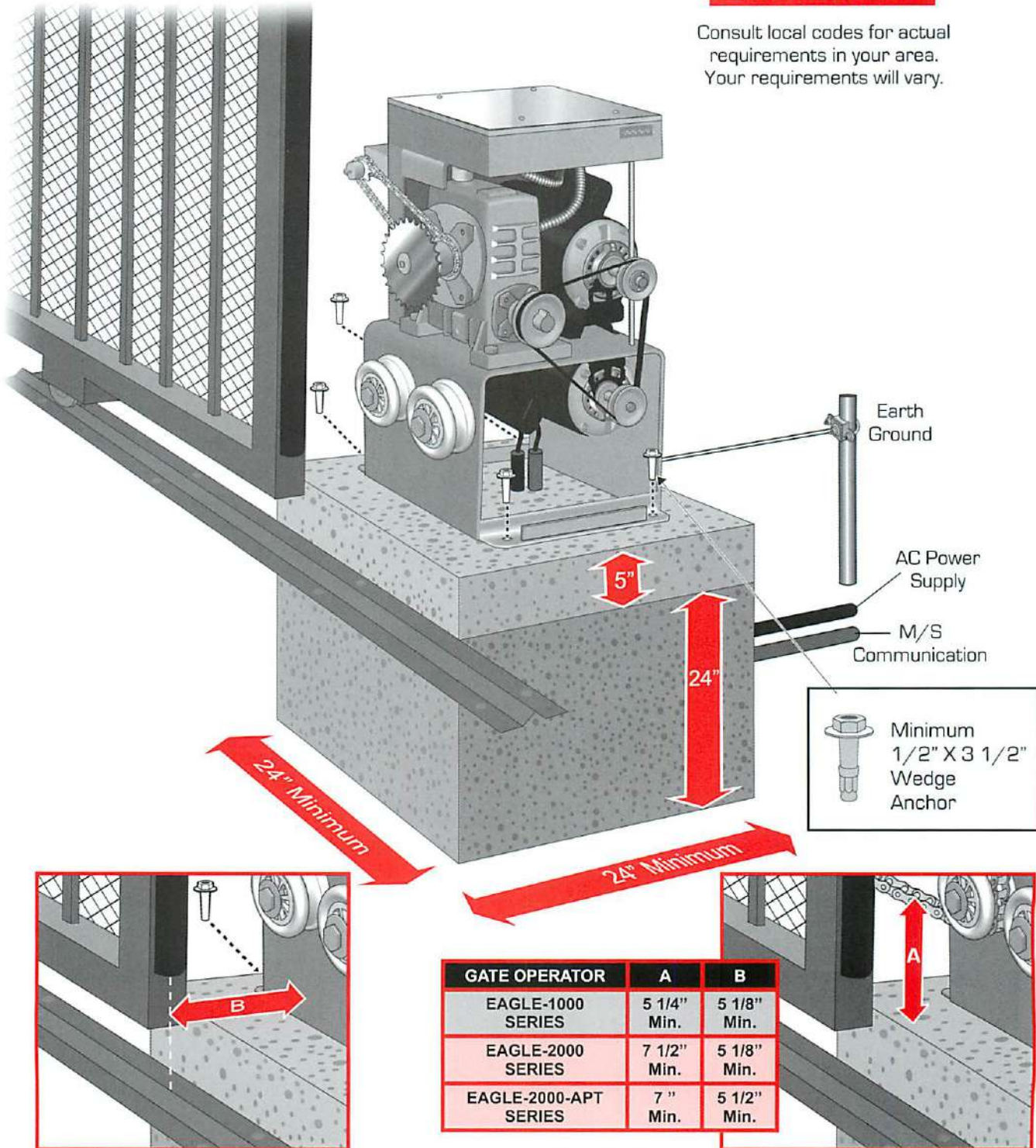

Minimum distance from center of gate to edge of gate operator chassis.

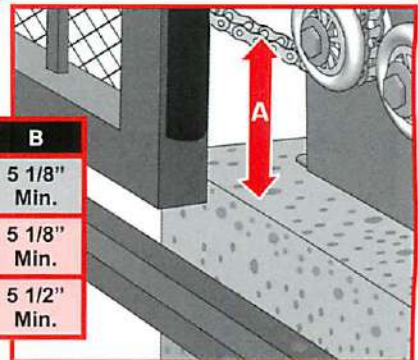

Minimum height of gate chain from bottom of operator chassis.

GATE OPERATOR	A	B
EAGLE-1000 SERIES	5 1/4" Min.	5 1/8" Min.
EAGLE-2000 SERIES	7 1/2" Min.	5 1/8" Min.
EAGLE-2000-APT SERIES	7" Min.	5 1/2" Min.



# EAGLE OPERATOR INSTALLATION

## MODEL SPECIFIC MOUNTING TEMPLATE

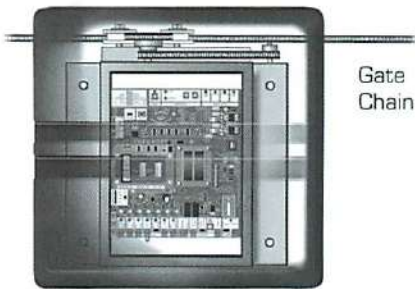

Gate Chain

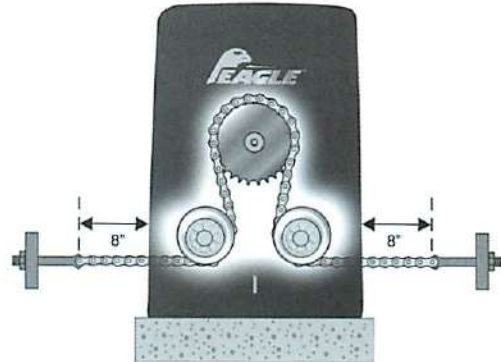

Recommended minimum pad size is 24" X 24". Your pad size may vary due to local building codes, site-specific issues, and the distance between the center of the gate and gate operator.

When the gate is in the fully open & fully closed position, it is recommended that approximately 8" be allowed between the chain bolt and gate operator cover.

### Position of Concrete Pad

To determine the position of your concrete pad, measure distance from center of gate track.

Using your model specific templates below, mark the position of your mounting holes and position of gate operator.

GATE OPERATOR	B
Eagle-1000 Series	5 1/8"
Eagle-2000 Series	5 1/8"
Eagle-2000-APT Series	5 1/2"

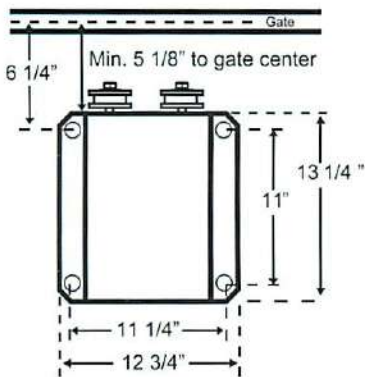
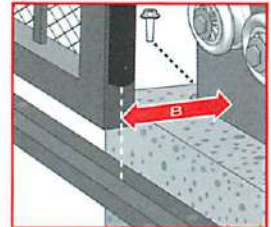

Eagle-1000 Series

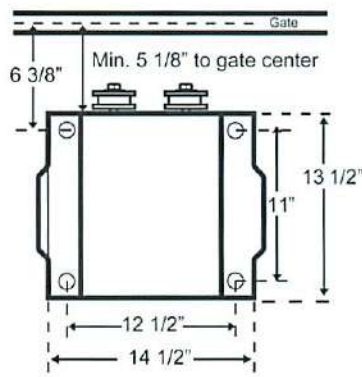

Eagle-2000 Series

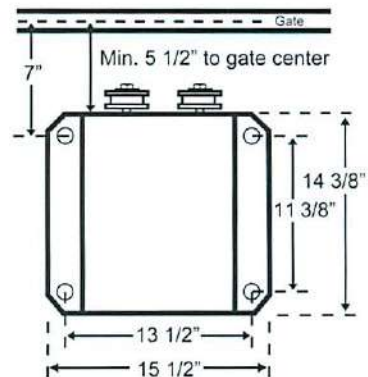

Eagle-2000-APT Series

### Size of Concrete Pad

To determine the size of your concrete pad, measure out from center of the gate operator. A minimum of 2" on each side of the gate operator cover is recommended.

Eagle-1000 Series

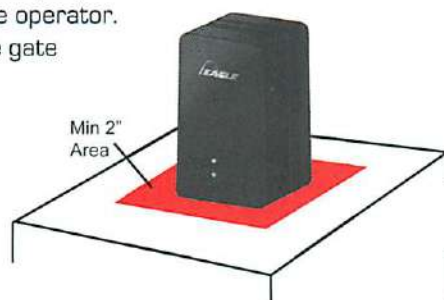

Eagle-2000 Series  
Eagle-2000-APT Series

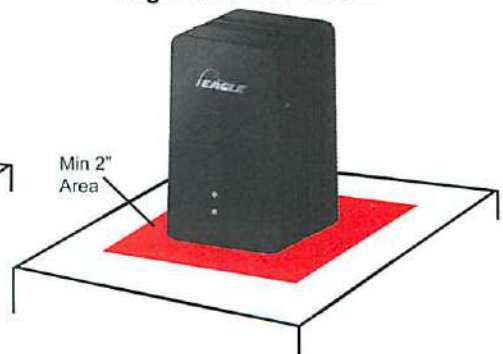

# EAGLE OPERATOR INSTALLATION

## CONNECTING THE CHAIN

Proper chain tension is approximately  $3/4$ " of slack for every 10 feet of gate length.

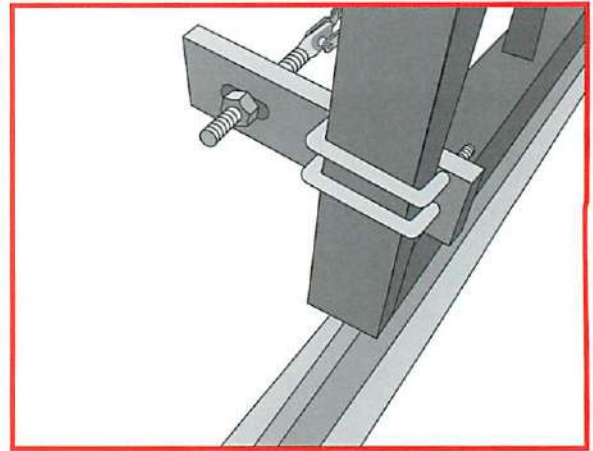
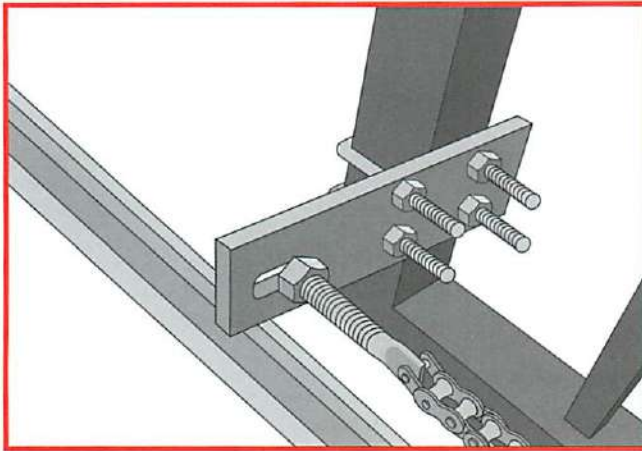
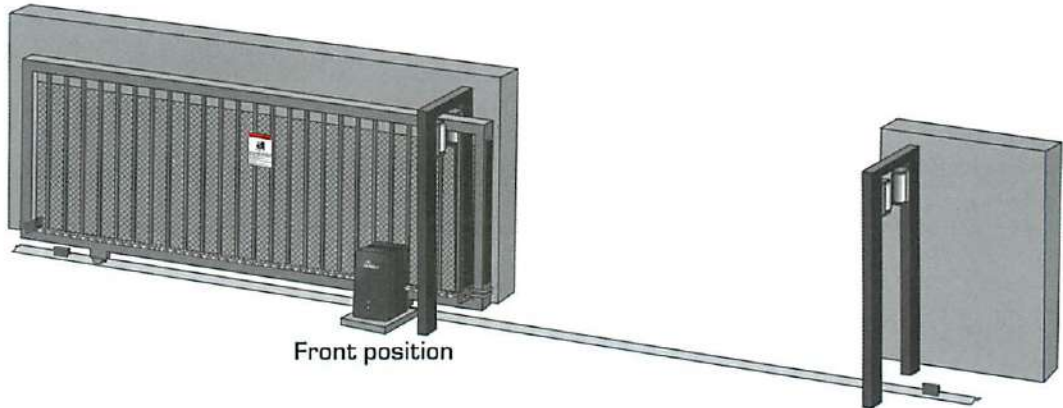

As shown, connect gate chain to front and rear of gate using supplied chain kit. Included is 20' of gate chain. Additional gate chain may be required.

Thread gate chain over drive sprocket as shown.

Optional Welding (Recommended)

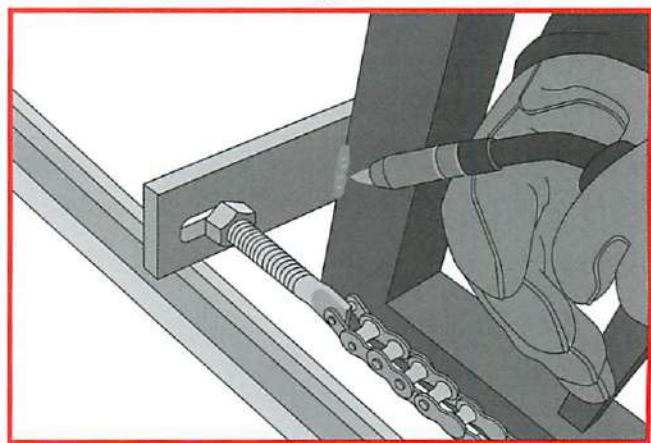
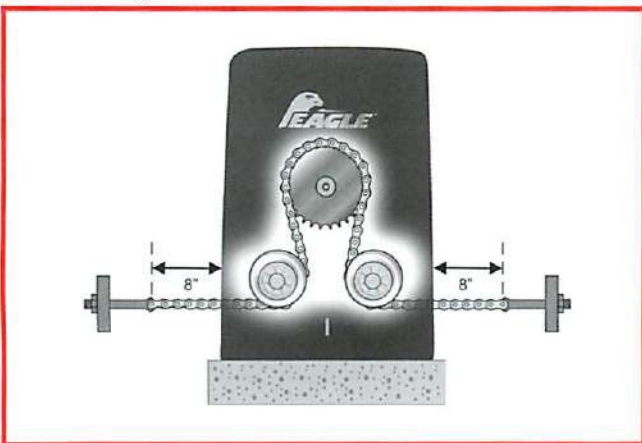



# EAGLE OPERATOR INSTALLATION

## CONNECTING THE CHAIN

Additional equipment required

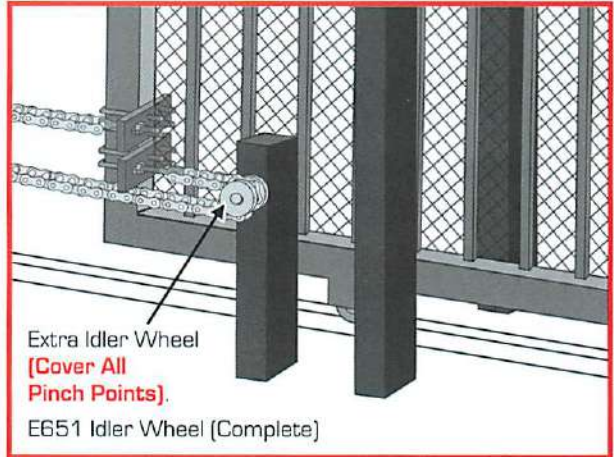
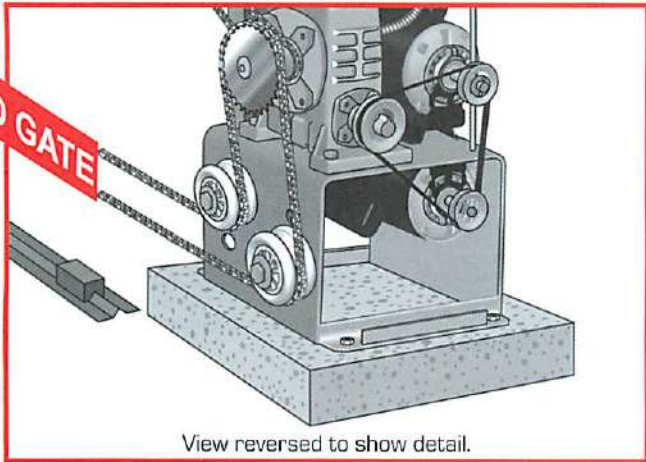
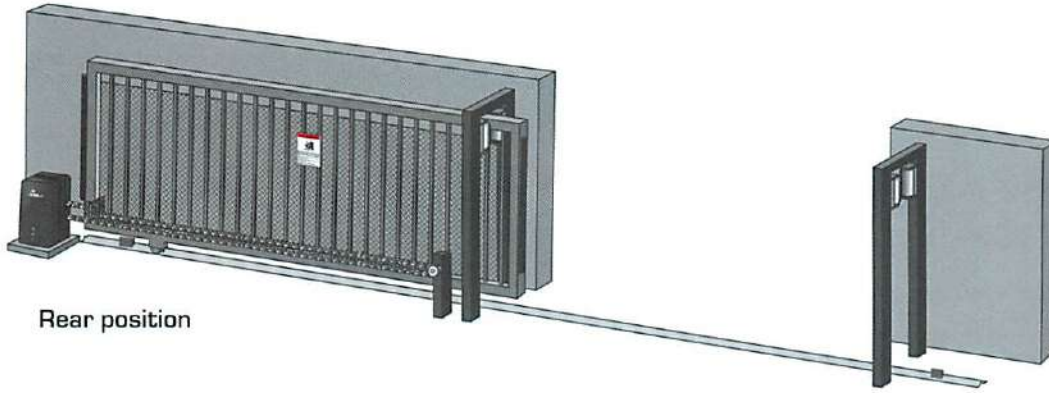

Connect both chain brackets to rear of gate.

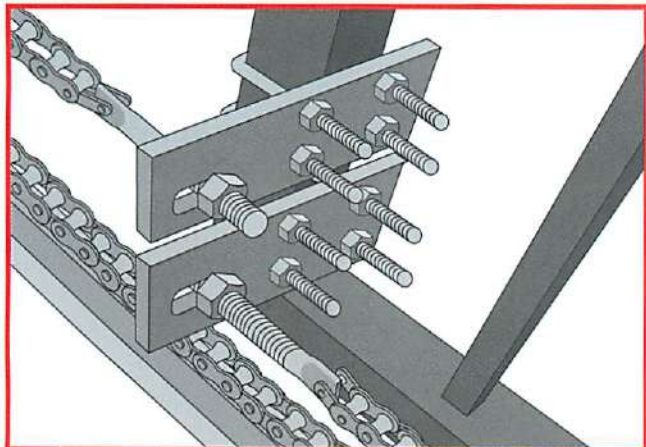

Optional Welding (Recommended)

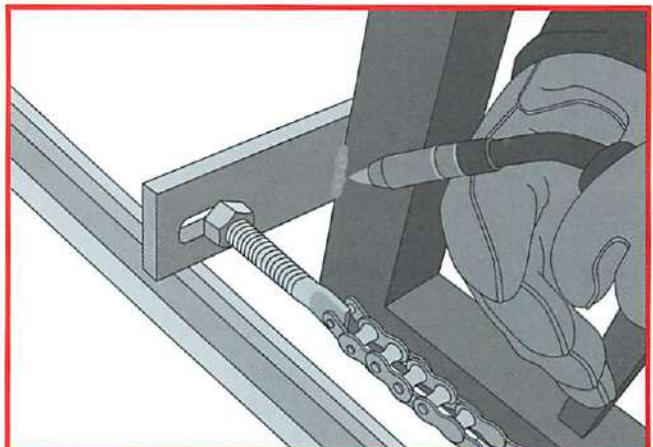

# EAGLE OPERATOR SET - UP & OPERATION

## INITIAL SET-UP

### Feature Selector

Locate the Feature Sector on the Eagle Diamond Control Board.

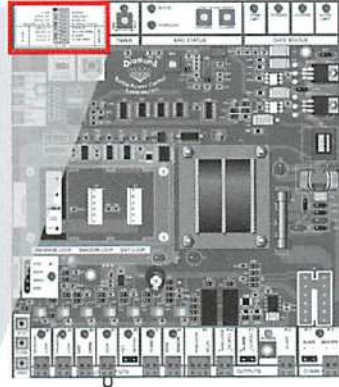
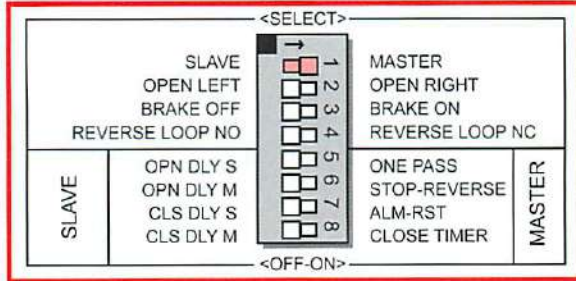

**Note:** The Power should be turned off when changing switch positions on Feature Selector. Press the Reset Button to clear the memory and allow microprocessor to accept new function.

### Switch 1: Single or Dual Gate Systems

Set to ON position (Master) for single gate operation or if Primary Operator (Master) in M/S System.

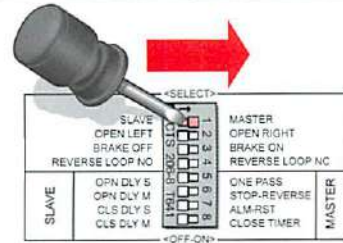

### Switch 2: Direction of Travel

Select Opening Direction for Gate. Off Position for OPEN LEFT, On Position for OPEN RIGHT (See Illustration below to determine opening direction).

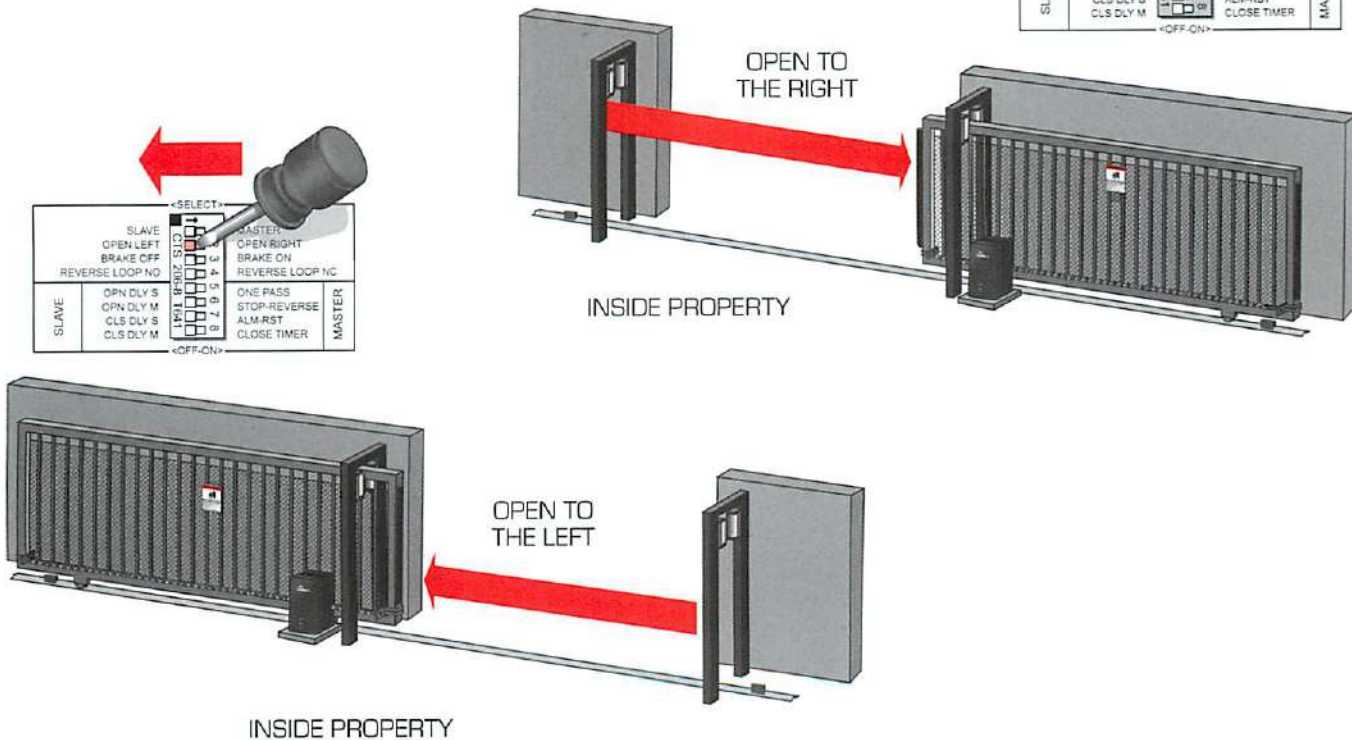
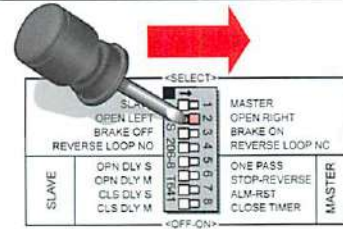



# EAGLE OPERATOR SET - UP & OPERATION

## INITIAL SET-UP (Continued)

### Limit of Travel

Only a Qualified Service Technician should make adjustments.

OPEN and CLOSE limits should be set to stop gate travel 2" - 3" before reaching any positive stop, gate post or obstruction.

To adjust travel limits, release Locking Plate from Limit Adjustment Cams and rotate Limit Adjustment Cam toward or away from limit switches.

Moving Limit Adjustment Cam closer to the limit switch decreases the travel distance. Moving the Limit Adjustment Cam away from the Limit Switch increases the travel distance.

Be sure the locking plate is returned to the locked position in each Limit Adjustment Cam.

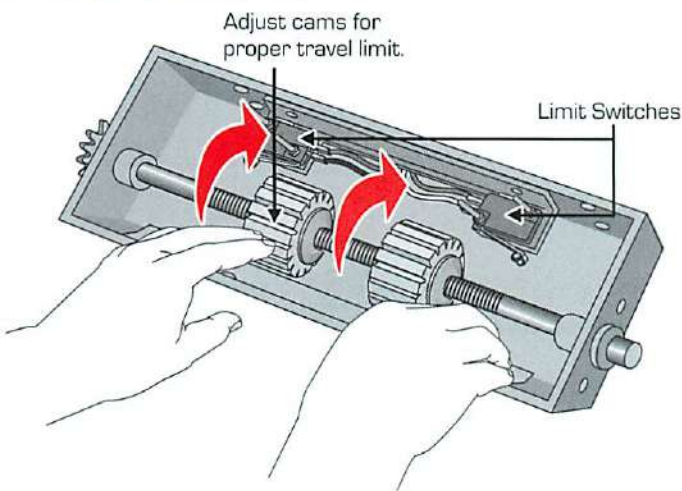

Be sure the locking plate is locked into place after each adjustment.

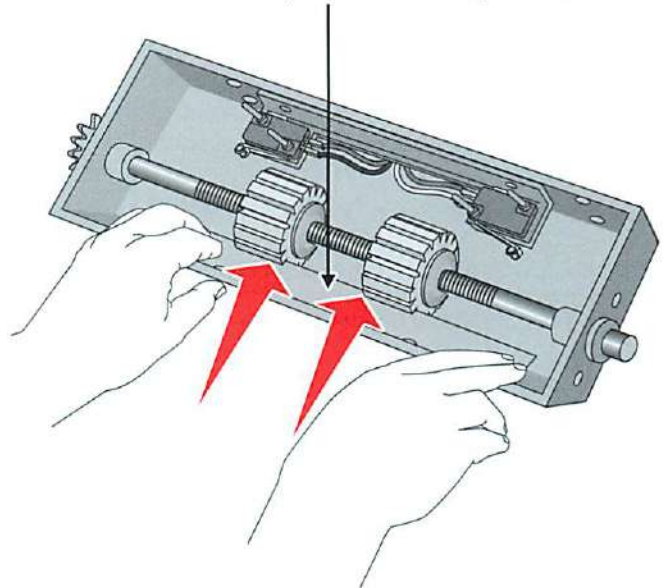

### Emergency Reversing Device

Only a Qualified Service Technician should make adjustments.

Proper Function of ERD - When properly set, ERD will function as follows. When meeting an obstruction in the closing direction, the gate will stop, reverse direction and return to the full open position. When meeting an obstruction in the opening direction, the gate will stop and reverse its direction and stop after approximately 4 - 6 inches. The gate operator will stay in an overload state for 5 minutes or until manually reset.

If the gate operator enters overload status two times in a row, the alarm siren will sound until manual reset.

Adjustment must be made so that the gate stops and reverses when meeting an obstruction equal to approximately 20 lbs of stopping force. Adjustment must be made in both the Opening and Closing direction of travel.

A qualified service technician must make all adjustments to the sensor.

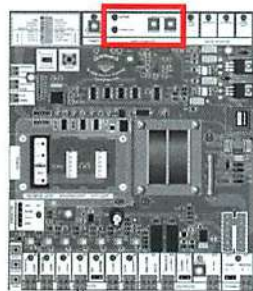
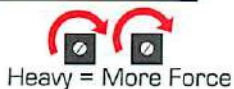
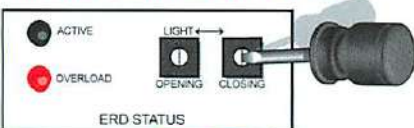

When adjusting sensors remember ...

1. Too Sensitive = if the gate stops or reverses by itself.
2. Not Sensitive Enough = if the gate strikes an object and does not stop or reverse.





# EAGLE OPERATOR SET - UP & OPERATION

## SUPPLEMENTAL FEATURE SELECTION

### SWITCH 3: Motor Brake for Heavy Gates

Motor Brake - If the "ON" position is selected, the motor will instantly reverse, applying a braking action when gate reaches the open or closed limit. This is useful on uphill / downhill applications and on all Fail - Safe operators.

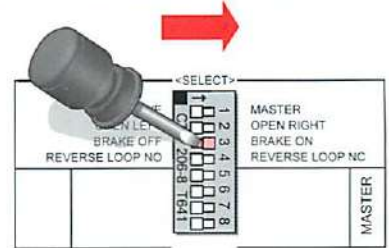

### SWITCH 4: Selectable Reverse Loop (NO or NC)

Reverse Loop - Depending on the device connected to the Reverse Loop input, you may need to change to ON position. If the ON position is selected the Reverse Loop input will be set to a Normally Closed (NC) circuit. Determine the requirement of your accessory before turning ON Switch 4.

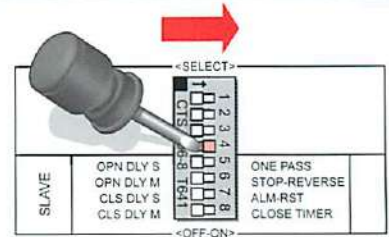

### SWITCH 5: One - Pass for Anti - tailgating

One Pass - If the ON position is selected, the Eagle anti-tailgating feature is in operation. After vehicle clears the inside loop area, the gate begins to close immediately without traveling to the open limit.

**Note:** Using the One Pass feature requires in-ground loop and loop detector.

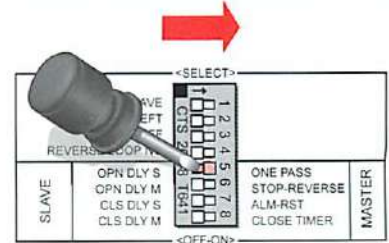

### SWITCH 6: Stop - Reverse for Convenience

Stop-Reverse - If the ON position is selected, this feature allows the transmitter to work as a 3 - button station for partial opening. The first command opens your gate, the second command stops your gate before opening all the way. The third command closes the gate.

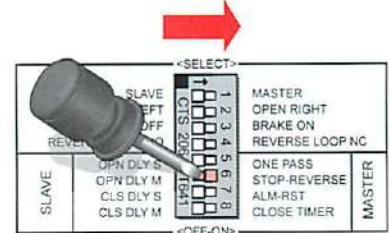

### SWITCH 7: Alarm Reset

Alarm Reset

If the "ON" position is selected, the gate operator will reset after a five minute "SHUT DOWN" time period, after which any input will be accepted.

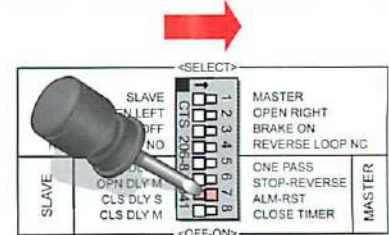

### SWITCH 8: Automatic Close Timer

Close Timer - If the ON position is selected, the close timer is made operational and your gate will close automatically. Adjust the time-to-close from 1 - 60 seconds.

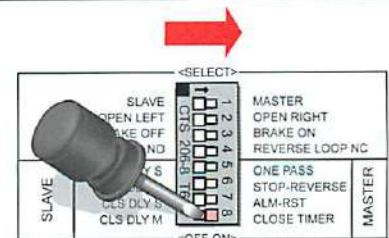
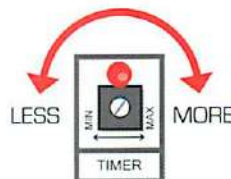



# EAGLE OPERATOR SET - UP & OPERATION

## PRIMARY & SECONDARY (M/S) OPERATION

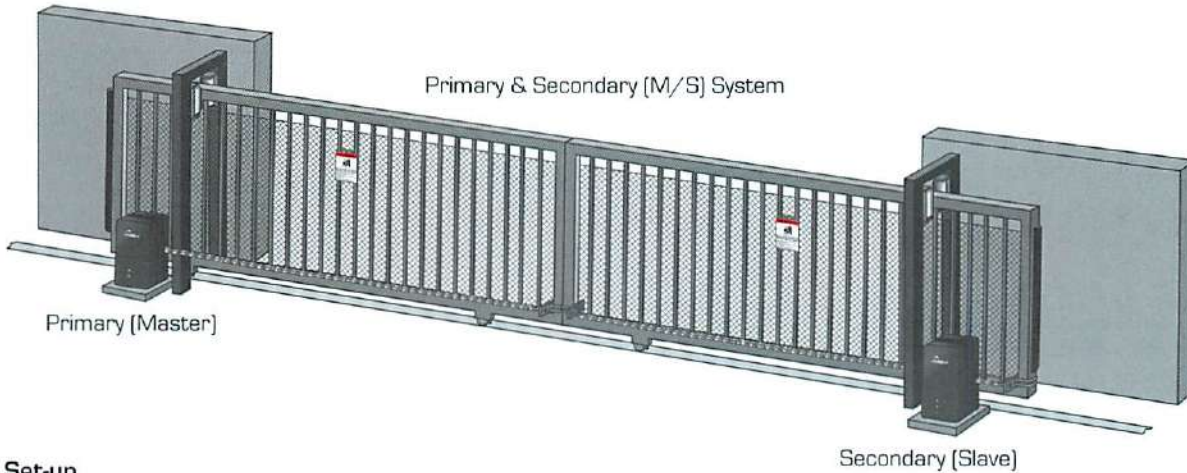

### Initial Set-up

**Note:** Before setting up a Primary & Secondary (M/S) System, it is recommended that each gate operator be made to operate as a stand - alone gate by completing initial set - up (Direction of Travel, Limit of Travel and Emergency Reversing Device and switches 1 -4). After each gate works individually, proceed to dual gate set - up and operation.

### Switch 1: Primary or Secondary (M/S) System

Turn Switch 1 to the ON position to select the Primary (Master) gate operator. Turn Switch 1 to the OFF position to select the Secondary (Slave) gate operator.

**Note:** The radio receiver (if used) must be installed on the Primary (Master) operator. All other accessory devices can be installed to Eagle's Global Inputs (Primary or Secondary Operator).

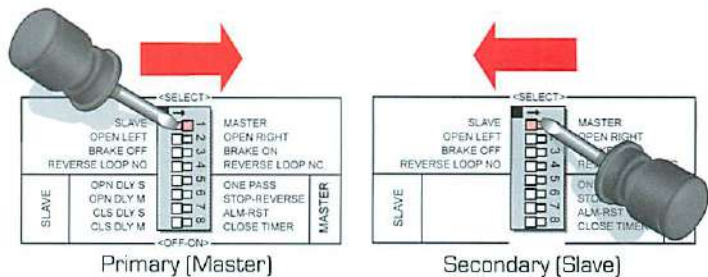

### Communication Port Connection

**Note:** Communication can be disrupted if the power source to each gate operator is out of phase. If each gate operator works independently, but not when connected at the communication port, the incoming AC power may be out of phase.

To properly phase the incoming AC power between each gate operator, move the M/S Phase Jumper one position on either the Primary or Secondary gate operator, but not both.

**Only move if communication is disrupted.**

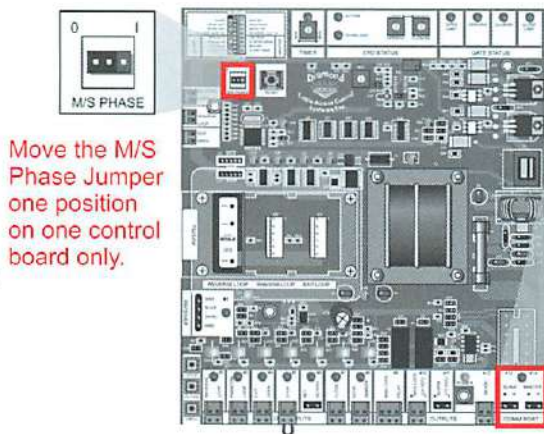

Using 20 ga Stranded Wire, connect the Primary Operator (Master) to the Secondary Operator (Slave) being sure to not cross polarity as shown.

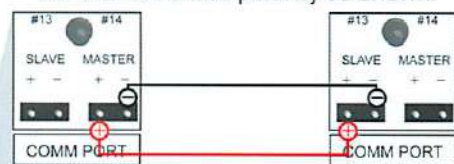

Use 20 ga stranded wire for Master / Slave communication.



# EAGLE OPERATOR SET - UP & OPERATION

## PRIMARY & SECONDARY (M / S) OPERATION

### SWITCH 5: (MASTER) Primary Operator: One - Pass for Anti-tailgating

One Pass – If the ON position is selected, the Eagle anti-tailgating feature is in operation. After vehicle clears the inside loop area, the gate begins to close immediately without traveling to the open limit.

**Note:** Using the One Pass feature requires in-ground loop and loop detector.

\* This feature is selected on the Primary (Master) operator

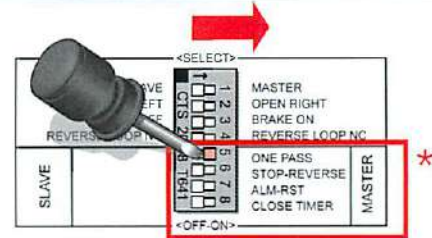

### SWITCH 6: (MASTER) Primary Operator: Stop-Reverse for Convenience

Stop-Reverse – If the ON position is selected, this feature allows the transmitter to work as a 3-Button Station for partial opening. The first command opens your gate, the second command stops your gate before opening all the way and the third command closes the gate.

\* This feature is selected on the Primary (Master) operator

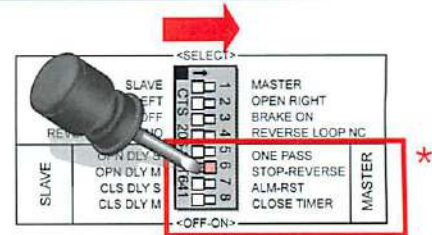

### SWITCH 7: (MASTER) Primary Operator: Alarm Reset

Alarm Reset

(On /Off) - If the "ON" position is selected, after five minutes "SHUT DOWN" time period, the operator will reset, and any input will be accepted. Normally, the power must be turned off to reset.

\* This feature is selected on the Primary (Master) operator

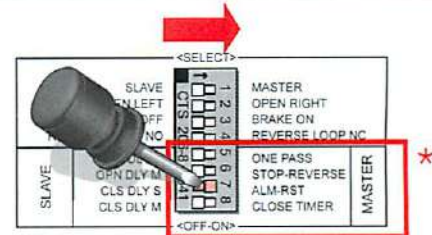

### SWITCH 8: (MASTER) Primary Operator: Automatic Close Timer

Close Timer – If the ON position is selected, the close timer is made operational and your gate will close automatically. Adjust the time to close from 1 – 60 seconds.

\* This feature is selected on the Primary (Master) operator

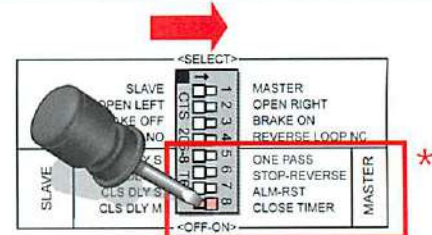
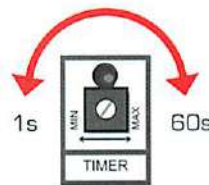

### Switches 5 - 8: (SLAVE) Secondary Operator Open & Close Delay

To positively control the opening and closing delay of each gate leaf, use Switch 5, 6, 7 & 8 on the Secondary (Slave) operator. Note: All Opening and Closing Delay selections can ONLY be set at the Secondary (Slave) operator.

#### Open Delay - Adds 1-1/2 Seconds to the Open Cycle

Delay Open (SLAVE) Secondary Operator Switch 5 to ON position

Delay Open (MASTER) Primary Operator Switch 6 to ON position

\*\*

#### Close Delay – Add Delay to Close Cycle of Either the Primary (Master) or Secondary (Slave) gate operator 0 - 6 seconds.

Switch 7 to ON Position Allows Close Delay of the Primary (Master) Operator

Switch 8 to ON position Allows Close Delay of the Secondary (SLAVE) Operator

After selecting Switch 7 or Switch 8 to ON position, use Timer on (SLAVE)

Operator to adjust close delay from 1 to 6 seconds.

\*\* These features are selected on the Secondary (Slave) operator

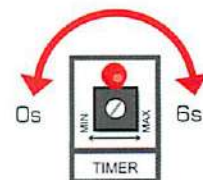
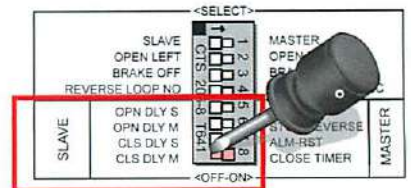



# ACCESSORIES

## RECEIVER ( Radio Controls)

Eagle Gate Operators work with all brands of receivers. Each Eagle Gate Operator has a pre-wired terminal strip, ready to receive a 3-wire or 4-wire receiver.

Consult the wiring diagram of your receiver for proper connection to the Eagle Receiver Terminal Strip. Shown is a typical 3-wire and 4-wire receiver installation.

If non-rolling code receiver is installed, be sure to personalize your code/frequency. See Receiver Manufacturer information.

**Note:** Dual Leaf Gate (M/S) Installation Receiver must be installed on Primary (Master) Gate Operator.

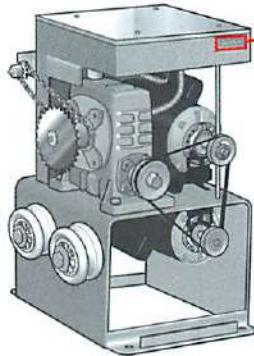

Location of Pre-wired Receiver Terminal Strip

Terminal Strip is **ONLY** for Receiver connection

### 3-Wire Connections

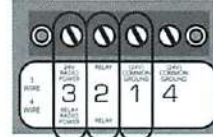

### 4-Wire Connections

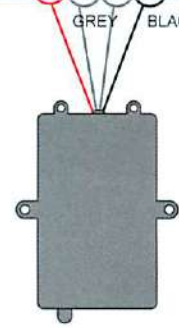
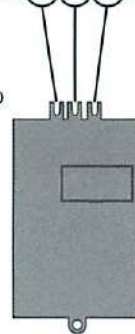
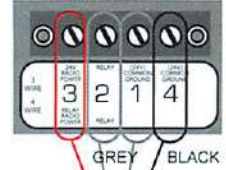

## PHOTO-EYE DETECTOR/NON-CONTACT SENSOR (Entrapment Protection)

The Eagle Diamond Control Board supports all brands of photo-eye detectors.

Connect photo-eye detector to the Reverse Loop input.

Consult wiring diagram for your photo-eye detector for proper connection to the Eagle Diamond Control Board. Note: Reverse Loop Input is selectable as NO or NC.



**GLOBAL INPUT** connects to Primary or Secondary

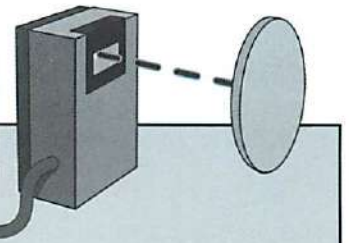
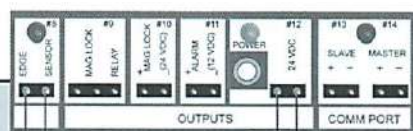
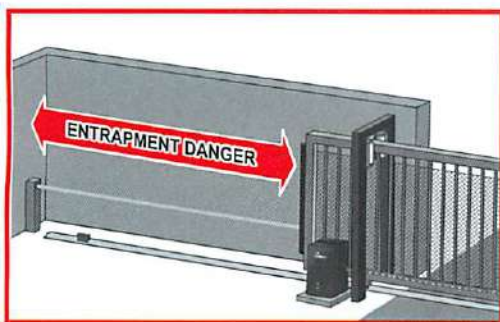
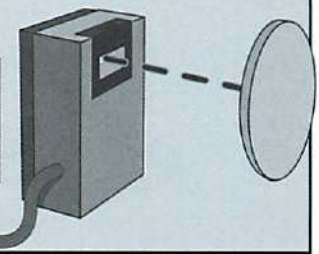
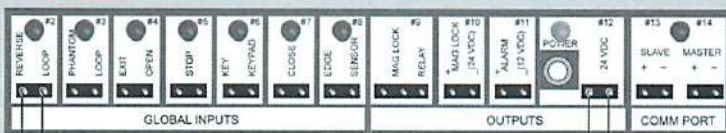
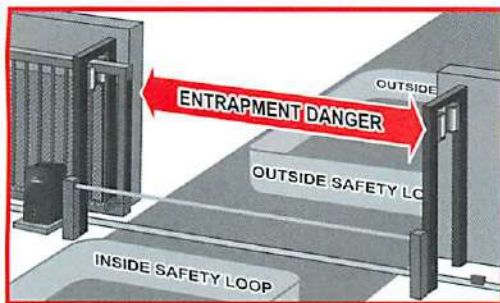

**Note:** When protecting areas of entrapment when gate is reversing, connect non-contact sensor to Edge Sensor input.



# ACCESSORIES

## IN-GROUND LOOPS & LOOP DETECTORS

Inductive loop systems are made up of an in-ground wire loop and an Eagle Plug-in Loop Detector (Eagle Part# EG169). The Loop Detector powers the loop and causes a magnetic field to form, creating a resonant frequency which is monitored by the Eagle Loop Detector.

When a vehicle enters or crosses the loop area, it causes the loop inductance to decrease, changing the resonant frequency. If the frequency change exceeds the threshold set by the sensitivity of the loop detector a detect signal will be sent to the Eagle Diamond Control Board.

**NOTE:** Use only Eagle brand Plug-in Loop Detectors.



**GLOBAL INPUT**  
connects to Primary  
or Secondary

1/8" to 1/4" Width Saw Cut

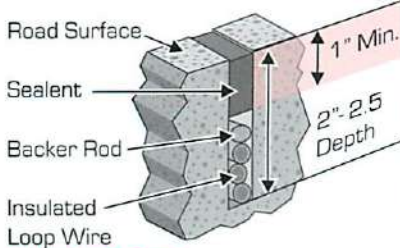

(Number of Turns  
Dependent on  
Loop Size).

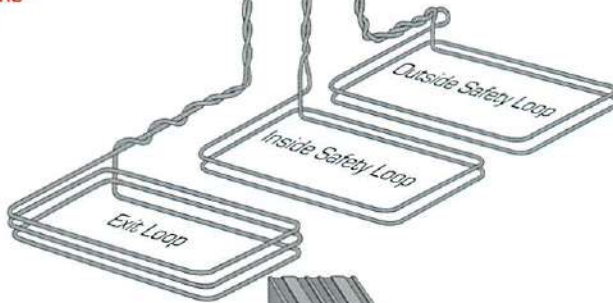

**NOTE:** External Loop Detectors can be used. See loop detector instructions for your wiring diagram.

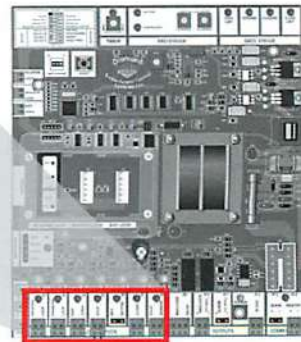
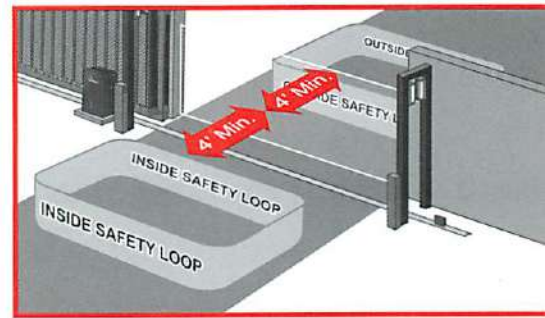
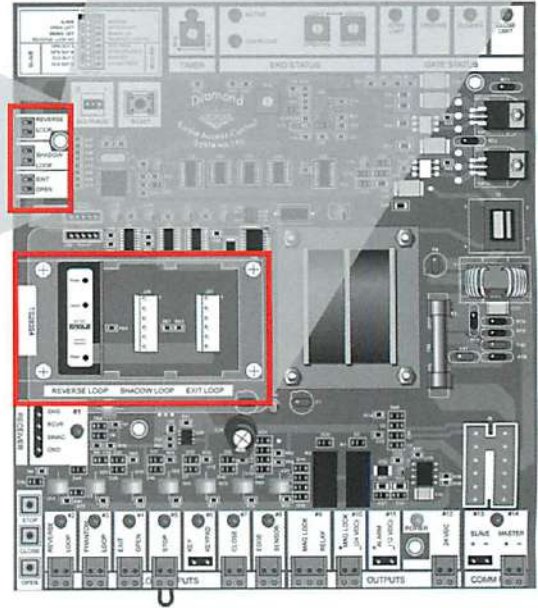
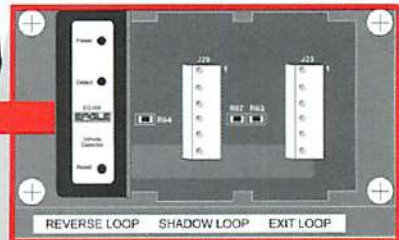
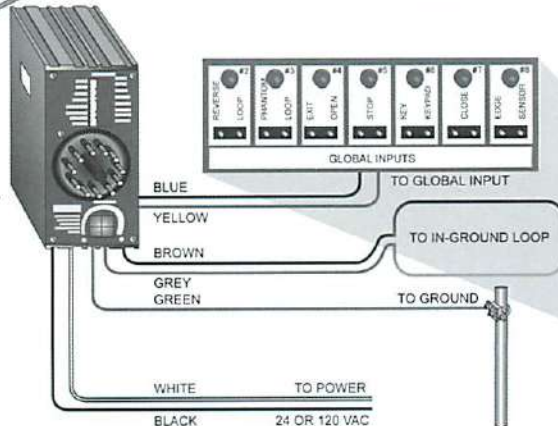



# ACCESSORIES

## EDGE SENSOR ENTRAPMENT PROTECTION

Connect Edge Sensors to Edge Sensor Input. When touched, the edge sensor sends a signal to stop the gate. Edge Sensors are placed in areas of entrapment in front and/or behind the gate.

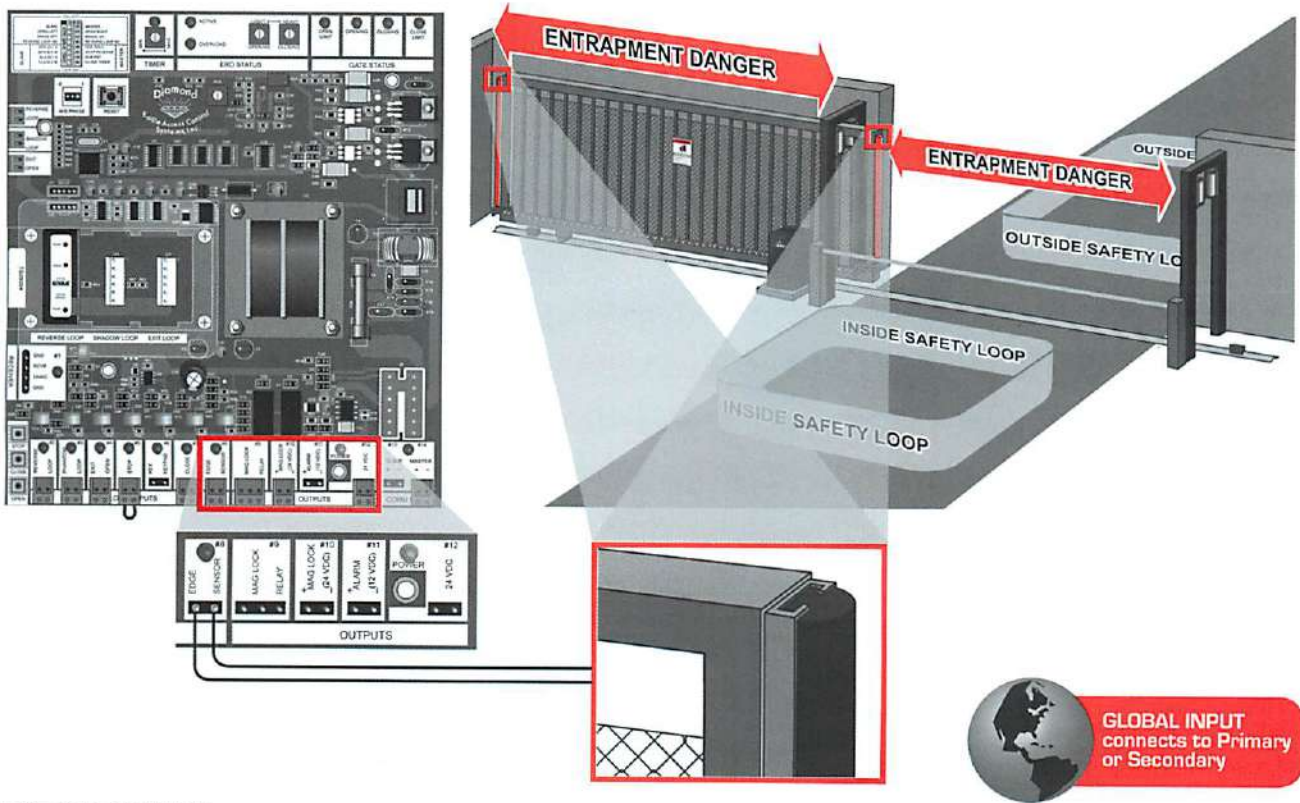

## 3-BUTTON STATION

Stop Button replaces factory supplied jumper on Stop input. The Stop input is a NC circuit.

Connect wire from correct side of 3-Button Station to correct side inputs on control board (right side of device to right side of input connector / left side of device to left side of input connector).

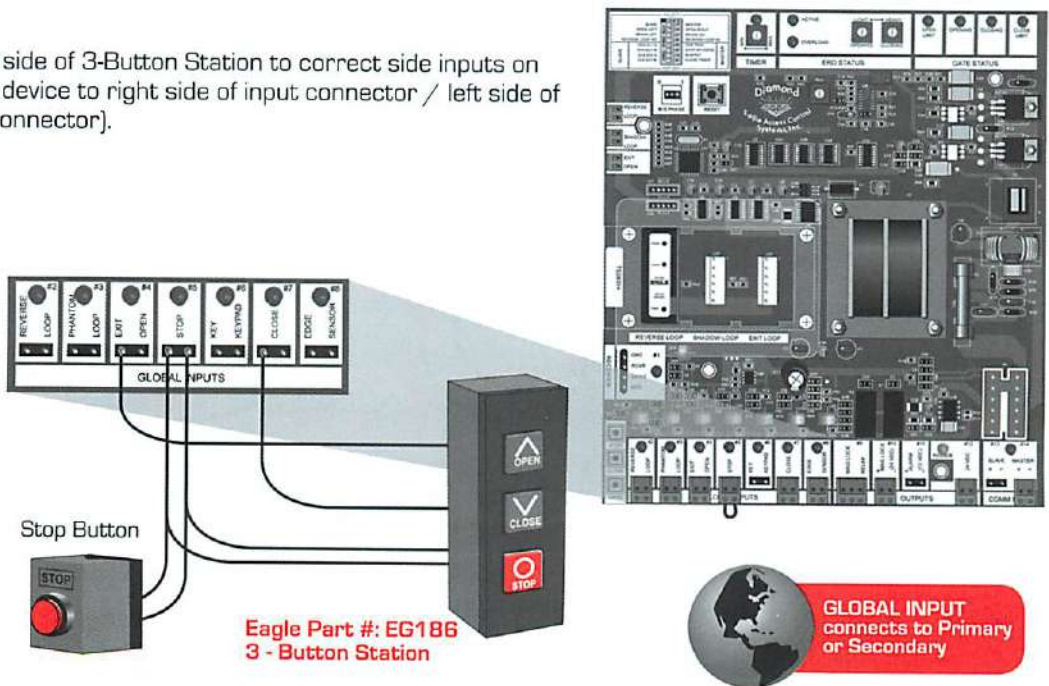

Eagle Part #: EG186  
3 - Button Station

# ACCESSORIES

## CHAIN RELEASE FIRE BOX

Manual chain release for emergency gate operation

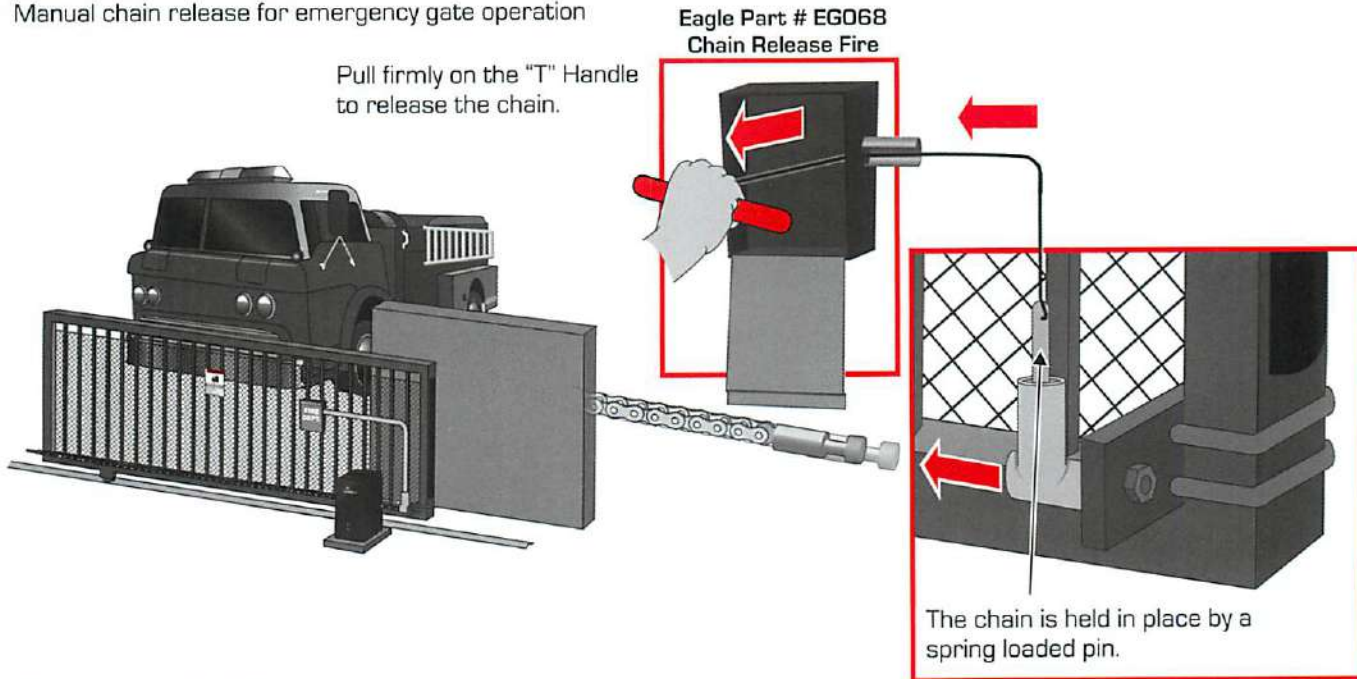

## FIRE & KEY LOCK BOXES

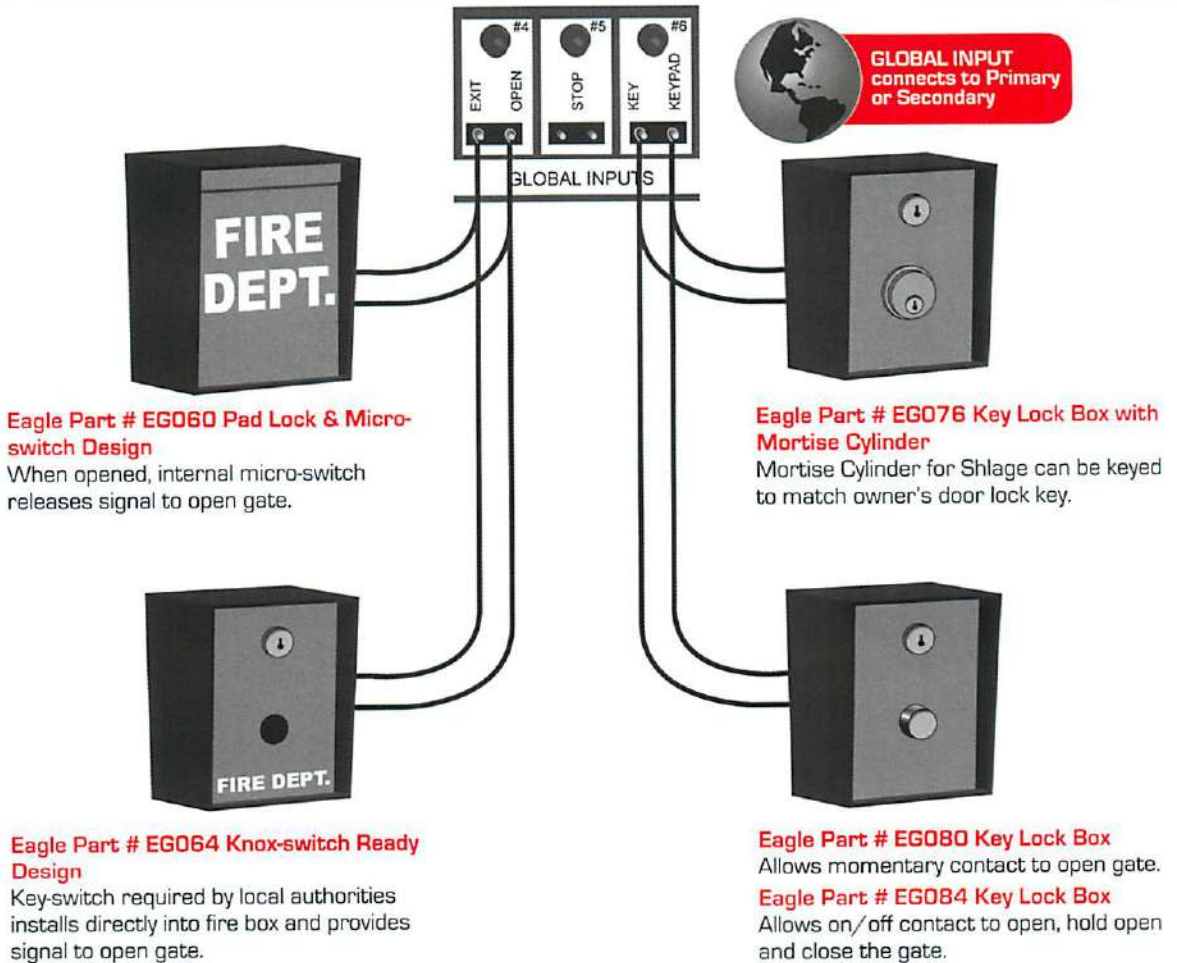



# ACCESSORIES

## KEY PADS, PROXIMITY READERS & TELEPHONE ENTRY

Most access control devices, such as key pads, proximity card readers, and telephone entry systems connect to the exit open input.

**Note:** exit open input [NO] recognizes only a command to open the gate and ignores a command to close the gate.

Key Keypad Input [NO] recognizes a command to open and close the gate.

**Important:** It is recommended that electronic devices such as keypads, proximity card readers and telephone entry systems have their own power transformer. See power requirements for your device.



**GLOBAL INPUT** connects to Primary or Secondary

## MAGNETIC LOCK

Connect the magnetic lock to the output labeled Mag Lock relay (**NOTE:** No solenoid or external relay required).

Mag lock output provides 24 VAC power and relay.

Check power requirements for your device.

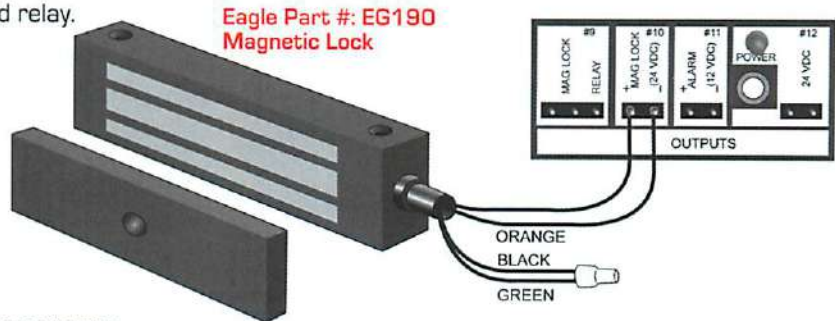

**GLOBAL INPUT** connects to Primary or Secondary

## DRY CONTACT RELAY (ADDITIONAL ACCESSORIES)

For additional accessories such as strobe light or audible alarm, a Dry Contact Relay is available for both normally open (NO) and normally closed (NC) circuits.

**Note:** This output triggers a device while the gate is in motion in both the opening and closing direction.

**\*\*Note:** Power source can be 12-120 V AC/DC.

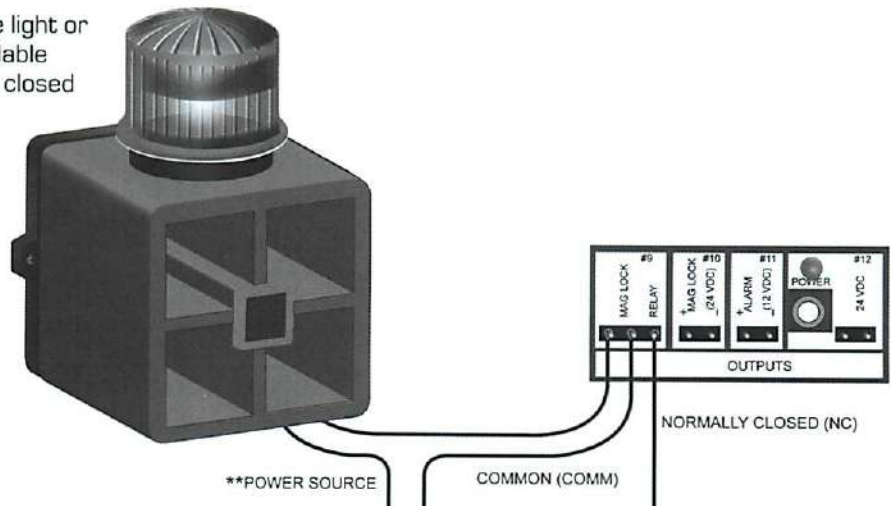

**GLOBAL INPUT** connects to Primary or Secondary

# OPERATOR PARTS

## EAGLE-1000, EAGLE-2000 & EAGLE-2000-APT SERIES

**Note:** Illustrations may not be to scale and are designed as representative parts and components. Some parts are shared by each gate operator model. See page at right for the Item Number, Part Number, and Description for your specific gate operator model.

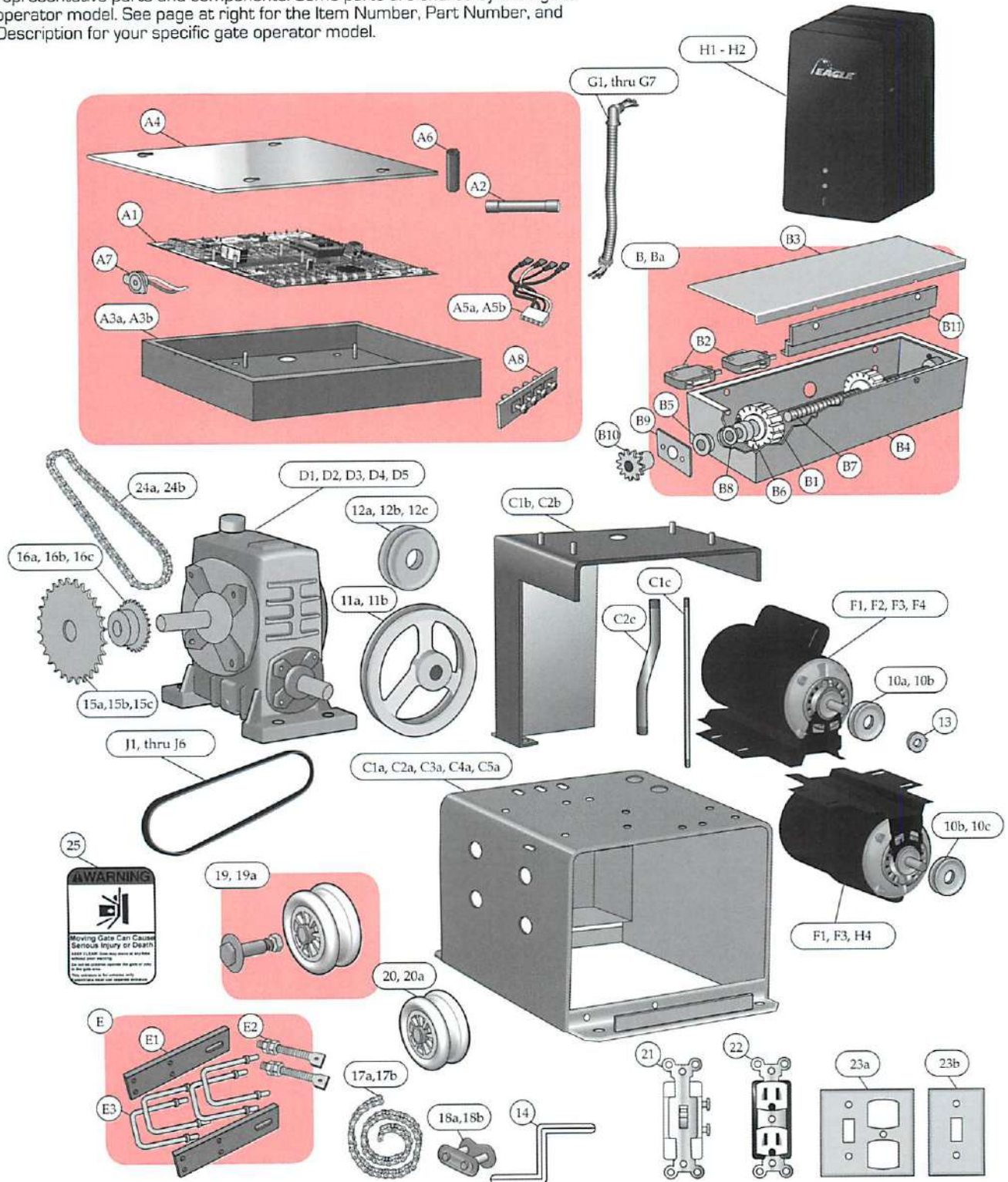



# OPERATOR PARTS

## EAGLE-1000, EAGLE-2000 & EAGLE-2000-APT SERIES

ITEM	PART NO.	DESCRIPTION (INCLUDING MODEL OR OPERATOR)
A1	E555	Eagle Diamond Control Board
A2	E556	15 Amp Slow Blow Fuse (Diamond Control Board)
A3a	E553	Control Board Box (Eagle-2000 Series & Eagle-2000-APT Series)
A3b	E292	Control Board Box (Eagle-1000 Series)
A4	E293	Cover - Control Board Box
A5a	E032	Receiver Harness (Eagle-2000 & Eagle-2000-APT Series)
A5b	E022	Receiver Harness (Eagle-1000 Series)
A6	E561	Eagle Diamond Control Board Stand - off
A7	E562	Eagle Siren
A8	E563	Receiver Terminal Strip

ITEM	PART NO.	DESCRIPTION (INCLUDING MODEL OR OPERATOR)
B	E106	Limit Switch Assembly (Eagle-2000 & Eagle-2000-APT Series)
Ba	E094	Limit Switch Assembly (Eagle-1000 Series)
B1	E108	Limit Adjustment Cam - Limit Switch Assembly
B2	E097	Limit Switch - Limit Switch Assembly
B3	E107	Cover Plate - Limit Switch Assembly
B4	E110	Limit Box - Limit Switch Assembly
B5	E098	Bearing - Limit Switch Assembly
B6	E100	Shaft Collar - Limit Switch Assembly
B7	E109	Threaded Shaft - Limit Switch Assembly
B8	E112	Nylon Washer - Limit Switch Assembly
B9	E113	Retaining Plate with Screws - Limit Switch Assembly
B10	E099	Sprocket - Limit Switch Assembly
B11	E119	Locking Plate - Limit Switch Assembly

ITEM	PART NO.	DESCRIPTION (INCLUDING MODEL OR OPERATOR)
C1a	E200	Lower Chassis (Eagle-2000-FSF & Eagle-2000-FSC)
C1b	E201	Upper Chassis (Eagle-2000 & Eagle-2000-APT Series)
C1c	E202	Support - Chassis (Eagle-2000 & Eagle-2000-APT Series)
C2a	E203	Lower Chassis (Eagle-2000-1HP/DM)
C2b	E198	Upper Chassis (Eagle-1000 Series)
C2c	E211	Support - Chassis (Eagle-1000 Series)
C3a	E206	Lower Chassis (Eagle-2000-APT)
C4a	E214	Lower Chassis (Eagle-2000-APT 1.5HP/DM)
C5a	E199	Lower Chassis (Eagle-1000 Series)

ITEM	PART NO.	DESCRIPTION (INCLUDING MODEL OR OPERATOR)
D1	E181	Gear Reducer (Eagle-2000-FSF, Eagle-2000-1HP/DM)
D2	E251	Gear Reducer (Eagle-2000-FSC)
D3	E252	Gear Reducer (Eagle-2000-APT Series)
D4	E281	Gear Reducer (Eagle-1000-FSF)
D5	E159	Gear Reducer (Eagle-1000-FSC)

ITEM	PART NO.	DESCRIPTION (INCLUDING MODEL OR OPERATOR)
E	E300	No-Weld Chain Kit (chain not included)
E1	E305	Chain Bracket
E2	E306	Chain Bolt with Nuts
E3	E307	U-Bolt with Nuts - Chain Kit

ITEM	PART NO.	DESCRIPTION (INCLUDING MODEL OR OPERATOR)
F1	E185	1/2 HP Motor with Keyway (Eagle-2000 Series)
F2	E209	1/2 HP Motor with Keyway (Eagle-1000 Series)
F3	E210	1 HP Motor with Keyway (Eagle-2000-APT & Eagle-2000-APT-DM)
F4	E288	3/4 HP Motor with Keyway (Eagle-2000-APT-1.5HP)

ITEM	PART NO.	DESCRIPTION (INCLUDING MODEL OR OPERATOR)
G1	E031	Motor Harness with Flex & Connectors (Eagle-2000-FSF & Eagle-2000-FSC)
G2	E404	Motor Harness with Flex & Connectors (Eagle-2000-1HP)
G3	E405	Motor Harness with Flex & Connectors (Eagle-2000-DM)
G4	E406	Motor Harness with Flex & Connectors (Eagle-2000-APT)
G5	E407	Motor Harness with Flex & Connectors (Eagle-2000-APT-1.5HP)
G6	E408	Motor Harness with Flex & Connectors (Eagle-2000-APT-DM)
G7	E400	Motor Harness with Flex & Connectors (Eagle-1000 Series)

ITEM	PART NO.	DESCRIPTION (INCLUDING MODEL OR OPERATOR)
H1	E333	Cover - Gate Operator (Eagle-2000 & Eagle-2000-APT Series)
H2	E351	Cover - Gate Operator (Eagle-1000 Series)

ITEM	PART NO.	DESCRIPTION (INCLUDING MODEL OR OPERATOR)
J1	E283	V-Belt - Eagle-2000-FSF
J2	E282	V-Belt - Eagle-2000-FSC & Eagle-2000-APT
J3	E284	V-Belt - Eagle-2000-1HP/DM
J4	E603	V-Belt - Eagle-1000-FSF
J5	E604	V-Belt - Eagle-2000-APT-1.5HP/DM
J6	E285	V-Belt - Eagle-1000-FSC

ITEM	PART NO.	DESCRIPTION (INCLUDING MODEL OR OPERATOR)
10a	E266	Pulley - Motor (Eagle-1000-FSF & Eagle-2000-FSF)
10b	E255	Pulley - Motor (Eagle-1000-FSC & Eagle-2000-FSC/1HP/DM & Eagle-2000-APT Series)
10c	E275	Pulley - Lower Motor (Eagle-2000-1HP/DM)
11a	E144	Pulley - Gear Reducer (Eagle-2000-FSF/1HP/DM)
11b	E145	Pulley - Gear Reducer (Eagle-1000 FSF)
12a	E277	Pulley - Gear Reducer (Eagle-2000-FSC)
12b	E278	Pulley - Gear Reducer (Eagle-1000-FSC)
12c	E276	Pulley - Gear Reducer (Eagle-2000-APT Series)
13	E286	Crank Input
14	E257	Crank
15a	E166	Sprocket for Gate Chain - Gear Reducer (Eagle-2000 Series)
15b	E265	Sprocket for Gate Chain - Gear Reducer (Eagle-1000 Series)
15c	E371	Sprocket for Gate Chain - Gear Reducer (Eagle-2000-APT Series)
16a	E167	Limit Chain Sprocket - Gear Reducer (Eagle-2000 Series)
16b	E267	Limit Chain Sprocket - Gear Reducer
16c	E268	Limit Chain Sprocket - Gear Reducer (Eagle-2000-APT Series)
17a	XM208	10 ft., #40 Nickel-plated Roller Chain (Eagle-2000 & Eagle-2000-APT Series)
17b	XM200	10 ft., #41 Nickel-plated Roller Chain (Eagle-1000 Series)
18a	XM248	#40 Master Link
18b	XM244	#41 Master Link
19	E168	Idler Pulley Assembly Complete - Gate Chain (Eagle-2000 & Eagle-1000 Series)
19a	E651	Idler Pulley Assembly Complete - Gate Chain (Eagle-2000-APT Series)
20	E652	Idler Pulley - Gate Chain (Eagle-2000 & Eagle-1000 Series)
20a	E653	Idler Pulley - Gate Chain (Eagle-2000-APT Series)
21	E132	Main Power Cut-off Switch
22	E136	Electrical Outlet (Eagle-2000 & Eagle-2000-APT Series)
23a	E135	Switch Plate (Eagle-2000 & Eagle-2000-APT Series)
23b	E133	Switch Plate (Eagle-1000 Series)
24a	E242	Limit Chain (Eagle-2000 & Eagle-2000-APT Series)
24b	E241	Limit Chain (Eagle-1000 Series)
25	E997	Warning Sign



# INSTALLATION CHECKLIST, CARE & MAINTENANCE

## INSTALLATION CHECKLIST

A licensed contractor must perform all installation and maintenance. An Eagle Registered Dealer can be found at [www.eagleoperators.com](http://www.eagleoperators.com).

### For your Records

Gate Operator Model: \_\_\_\_\_

Serial Number: \_\_\_\_\_

Installing Contractor: \_\_\_\_\_

Tel: \_\_\_\_\_

- |   |   |
|---|---|
| <input type="checkbox"/> Safety Instructions, Proper Use of Controls and Gate Operator Understood | <input type="checkbox"/> Separate Pedestrian Gate Available (Automatic Gate is for Vehicle Traffic ONLY!) |
| <input type="checkbox"/> Entrapment Protection in Compliance with UL 325 (See Page 4)             | <input type="checkbox"/> All Controls Located Out of Reach of Gate and Gate Operator                      |
| <input type="checkbox"/> Positive Stops in Place  | <input type="checkbox"/> Wire Mesh Installed (4' from ground)   |
| <input type="checkbox"/> Warning Signs Installed  | <input type="checkbox"/> Gate Conforms to ASTM F 2200-02 Standards  |
| <input type="checkbox"/> Controls to Reset Gate Equipment in Line of Sight                        | <input type="checkbox"/> Warranty and Maintenance Plan Reviewed   |



## CARE & MAINTENANCE

Help extend the life of your equipment by following a few simple steps.

**1. Know your gate operator.** Monitor its operation and have any unusual symptoms looked at by an Eagle Registered Dealer.

**2. Make sure your gate operates smoothly.** Worn out or damaged wheels, hinges, accessories and other hardware can lead to premature wear.

**3. Inspect your gate operator.** Insects, ant colonies, mice and other rodents can find shelter under your gate operator cover. Dust, dirt and moisture can lead to premature wear. Inspect your gate operator every six months or at minimum once a year. Be sure the control board box remains well sealed and dry.

### POWER FAIL OPERATION

**FSC—Fail Secure Gate Operators:** A Fail-Secure gate operator cannot be "pushed" open or closed. Fail-Secure gate operators require a hand crank (included) to be manually moved.

#### Release Instructions:

1. Turn off the power - Failure to do so can result in serious injury.
2. Insert crank into the crank aperture.
3. Turn the crank to open the gate.

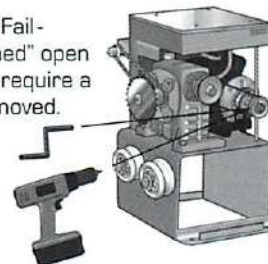

### ⚠ WARNING

Turn Power Off. Failure to do so can result in injury or death.

Note: To speed up the process, you may want to use a cordless power drill.

**FSF—Fail Safe Gate Operators:** A Fail-Safe gate operator automatically switches to manual operation. Without power, your gate can be operated manually while still connected to the Fail-Safe Eagle Gate Operator.

### RESTING THE MOTOR

In the event the gate operator is overloaded or overheats, the electric motor's thermal reset may need to be pressed.

#### EMERSON MOTOR

#### THERMAL RESET BUTTON



### ⚠ WARNING

Turn Power Off. Failure to do so can result in injury or death.

### RADIO CONTROLS (REMOTE CONTROLS)

If the signal strength (range or distance) of your remote control decreases, or if a transmitter stops working altogether, contact the manufacturer of the radio control system installed on your Eagle Gate Operator. Each remote transmitter & receiver works on a unique frequency and may be subject to electronic interference. See page 23 to locate your receiver make and model.







Dear Valued Customer,

Thank you for purchasing a new Eagle Gate Operating device and welcome to the convenience of trouble-free gate automation.

We take pride in the design and manufacture of each unit and stand behind our product with the industry's "Best-in-Class" warranty.

Your Eagle Gate Operator is rugged, durable and made to give you the reliable power you need and the ease of operation you expect.

Sincerely,

Joe Afriat  
*President & CEO*



Toll Free: 800-708-8848

[www.eagleoperators.com](http://www.eagleoperators.com)

[info@eagleoperators.com](mailto:info@eagleoperators.com)



Contact us:

Toll Free: 1 - 800 - 708 - 8848 • [www.eagleoperators.com](http://www.eagleoperators.com)

Copyright © 2011 Eagle Access Control Systems, Inc. All rights reserved.