



DUCATI
HOME AUTOMATION

SLIDE manual

REV000-09-07-19 ES



Installation instructions Sliding gate openers

models:

SLIDE 446 (Motor 12V, electronic board CTH46) = **SLIDE 646** = **SLIDE 600**

SLIDE 843/24V (Motor 24V, electronic board CTH43V/24V)

SLIDE 1043/24V (Motor 24V, electronic board CTH43V/24V)

SLIDE 446 SOLAR (Motor 12V, electronic board CTH46)

SLIDE 743/12V SOLAR (Motor 12V, electronic board CTH43V/12V)

<https://ducatihome.it>

DUCATI THE KIT CONTAINS

Content of the KIT: Click the kit item to visit the website page																	
	SLIDE-MOT 400 (12V)	SLIDE-MOT 700V-12V (FAST)	SLIDE-MOT 800V-24V (FAST)	SLIDE-MOT 1000V-24V (FAST)	CTH46 (12V)	CTH43N(12V)	CTH43V (12V) soft stop	CTH43V (12V) soft stop	CMBAT battery charger	CMBAT DISPLAY battery charger	MAGNO	RACK 8612 (RACK8622 dal 2021)	6208 / 6203R	SW5000	SW7500	SOLAR 1012	BAT 0712
SLIDE 446	1x	-	-	-	1x	-	-			-	2x	4m = 8x 50cm	2x	1x	1x	-	-
SLIDE 843/24V	-	-	1x	-	-	-	-	1x		-	2x	4m = 8x 50cm	2x	1x	1x	-	-
SLIDE 1043/24V	-	-	-	1x	-	-	-	1x		-	2x	4m = 8x 50cm	2x	1x	1x	-	-
SLIDE 446 SOLAR	1x	-	-	-	1x					-	2x	4m = 8x 50cm	2x	1x	1x	1x	1x
SLIDE 743/12V SOLAR	-	1x	-	-	-	-	1x		1*	1x**	2x	4m = 8x 50cm	2x	1x	1x	1x	1x

Note that this table shows the compositions of the standard kits. Special versions or different models may have different content than those shown here.





To check the exact content of the product you have purchased, please refer to your order and the composition of the product indicated in the order confirmation.

* = before August 2020 ** = from August 2020

Attention: from January 2021 the supplied frame could be the RACK8622 model with steel core and fixing slots

DUCATI LIMITS OF USE AND ENGINE TECHNICAL FEATURES

Motor characteristics for each model of KIT	KIT SLIDE 446 e KIT SLIDE 446 SOLAR with gearmotor model: SLIDE-MOT 400 (12V)	KIT SOLAR SLIDE 743 with gearmotor model: SLIDE-MOT 700V (12V) (FAST)	KIT SLIDE 843/24V with gearmotor model: SLIDE-MOT 800V (12V) (FAST)	KIT SLIDE 1043/24V with gearmotor model: SLIDE-MOT 1000V (12V) (FAST)
Supply	12V dc	12V dc	24V dc	24V dc
Power	240W	300W	300W	500W
Maximum thrust	2000N	2300N	2800N	3200N
Speed	10m/ min	12m/ min	12m/ min	12m/ min
Maximum gate weight	400kg	700kg	800kg	1000kg
Operating temperature	-20°C / +60°C			
Magnetic limit switch	√			
Frequency of use	Ideal for continuous intensive use			

Characteristics of the electronic board for each model KIT	KIT SLIDE 446 E KIT SLIDE 446 SOLAR with electronic board CTH46	KIT SLIDE 743 SOLAR with electronic board CTH43V (12V) and CM- BAT DISPLAY	KIT SLIDE 843/24V with electronic board CTH43V (24V)	KIT SLIDE 1043/24V with electronic board CTH43V (24V)
		 		
Power supply	For 230V sector (110V on request) / from 12V 7A emergency battery / 12V min 10W solar panel (with battery). Management of battery charge and energy from on board solar panels. It does not require any additional modules. DUCO-SOL energy saving technology	For 230V sector (110V on request) / for solar panel and 12V 7A buffer battery Attention: to be powered by the solar panel you need the Ref. CMBAT DISPLAY battery charger module included in the kit	From 230V sector (110V on request) / from 2x 12V emergency battery Attention: to be powered by the emergency battery it is necessary to add the battery charger module Ref.CMBAT * * optional accessory Warning: use 2 12V batteries in series. If only a 12V buffer battery is used, it can be housed in the engine block, but the engine will only run at low speed. Attention: the pair of 12V 12A batteries must be housed in an external container (not included)	
Toroidal transformer	√ 105W 230V (11V) exit 0 (black) -12V (yellow) -24V (red)			
Supply voltage	12V		24V	
Regular shutdown. Double speed with deceleration from standstill	-		√	
Stand-by power consumption	0,007A			
Protection fuse	Automatic			
Transformer protection fuse	0,8A T (1,2A T)			
DUCATI 433.92 MHz 2-channels radio receiver with variable code coding (Ducati rolling code)	Integrated			
Memory capacity of the radio receiver	20 channels			
Self-learning of remote controls			√	
Integrated antenna on board	√		√	
Automatic closing with adjustable pause time	0-100 sec.		0-100 sec.	
Amperometric obstacle detection safety system			√	
Motor power adjustment (obstacle sensitivity)			√	
Reverse ASR			√	
Services power output (e.g. photocells; external receiver)	12V dc		24V dc	

Scheme	Page	See also the drawings
The contents of the kit follow the model / limits of use / technical characteristics	2-3	
Mechanical installation drawings	5-10	
CTH46 electronic board diagram	11	
CTH43 electronic board diagram	12-13	
Preliminary opinions and safety advice	14-15	
Preparations	16	
Engine: right or left positioning	16	3.1 / 3.2 / 3.3 page 6
Secure the engine	16	4.1 / 4.2 / 4.3 page 6
Manual engine release	16	5.1 page 7
Fix the rack to the gate	17	6.1 -6.6 page 7
Temporary positioning of the limit switches	17	7.1-7.2 / 8.1-8.3 page 8
Power supply: by 230V switch or solar panel	18	9a -9b page 9
Remote sending / storage of the 1st maneuver	18-19	10.1-10.4 / 11.1-11.3 page 10
Permanently position the limit switch magnets	19	12.1 page 10
Electrical connections and adaptation of CTH46 board	20-21	Page 11
Electrical connections and regulation of the CTH43 board (in version CTH43 N / CTH43V 12V and CTH43V 24V)	22-23	Page 12-13
Remote controls: store and delete codes	24	
Radio keypad: programming	25	
Key selector	26	
Flashing	27	
Photocells LASER 100 and LASER 100B	28	
Guarantee	29-30	
Register on our website	31	

1



2

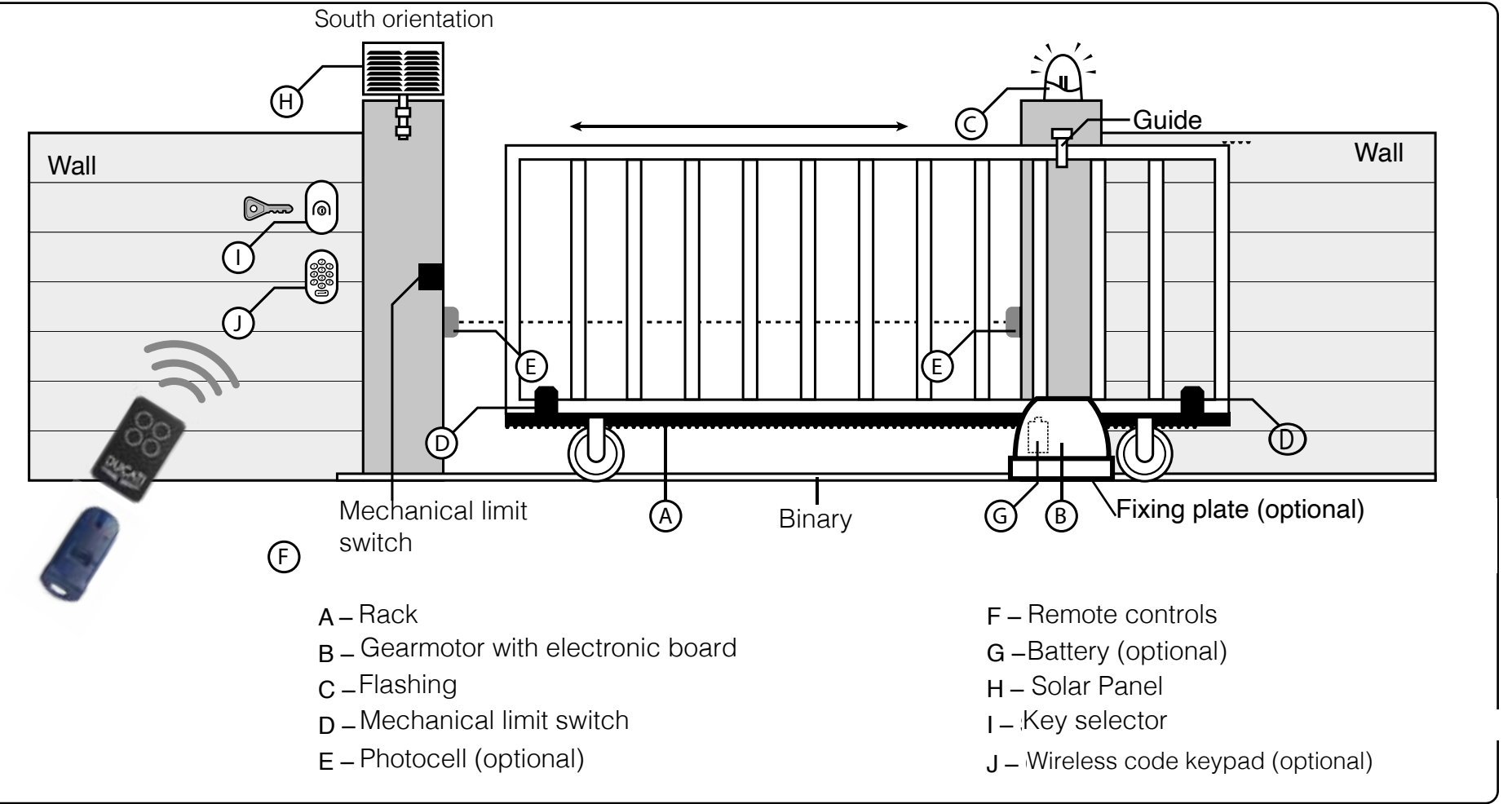

DUCATI DRAWING FOR QUICK INSTALLATION

3

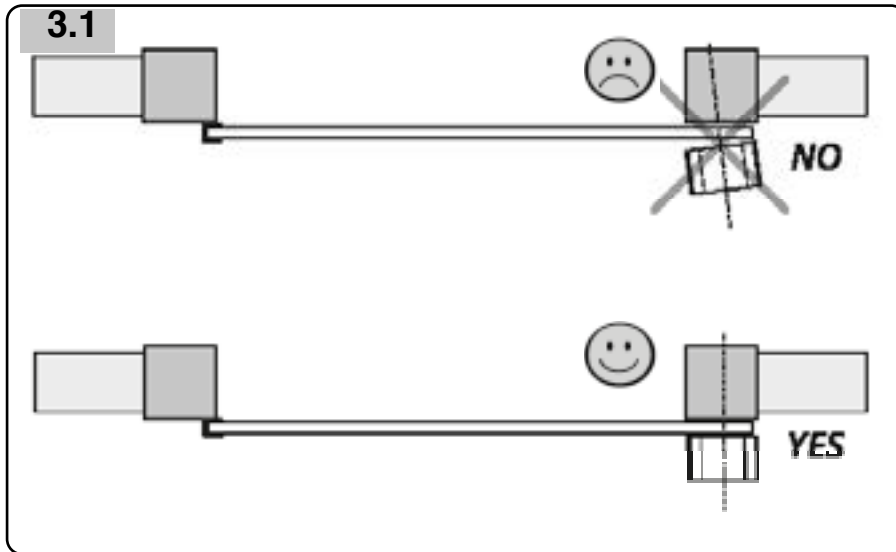

3.2 STANDARD right opening Red Blue

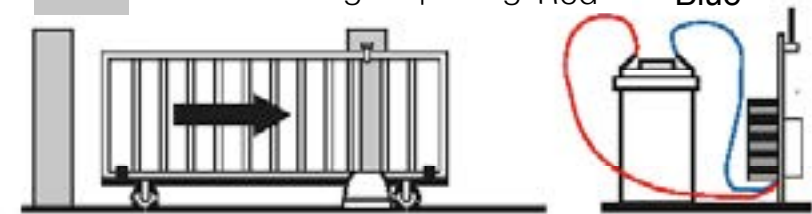

3.3 Left opening Blue Red

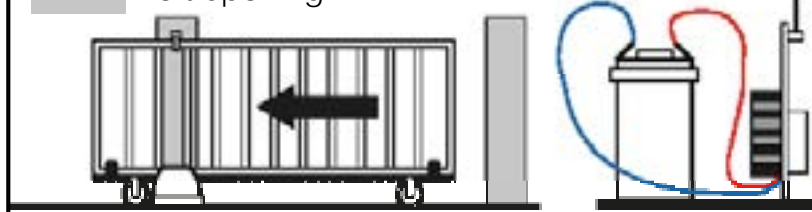

4

4.1 Direct fixing to the ground

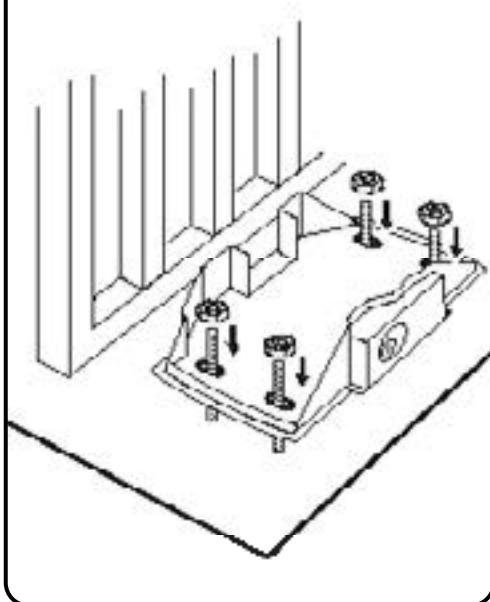

4.2

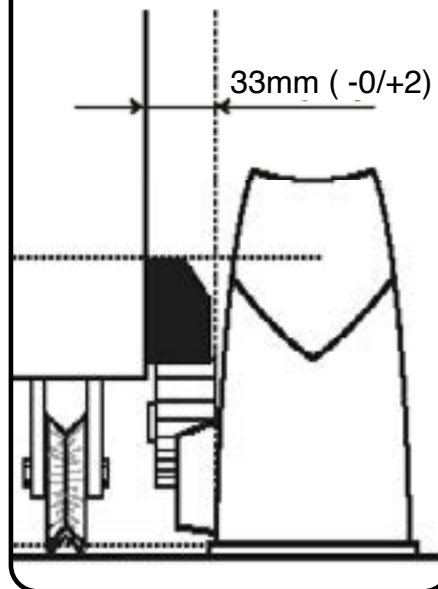

4.3 PLAK 8700 fixing plate (optional)

Attention, adjust the position of the motor on the plate to the maximum height. In the future it can therefore be adapted to the normal lowering of the gate

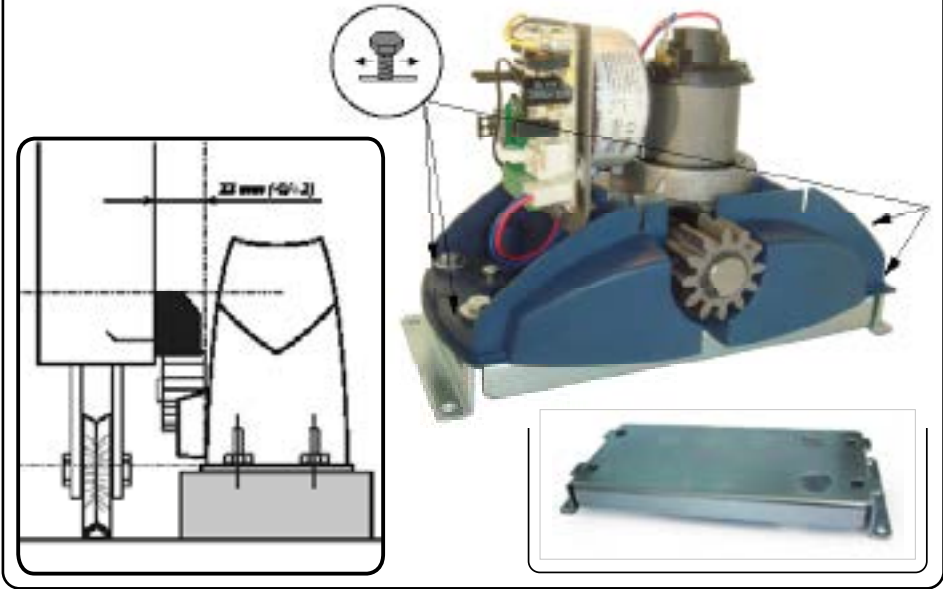

5

5.1

To block

To unlock

6

6.1

25mm

40mm

6.2

1-2mm max.

6.3

NO

SI

6.4

portale

33 mm (-0/+2)

72 mm (-0/+2)

6.5

Place the rack on the gear, one piece at a time.

6.6

Fix the rack piece by piece passing the same distance from the gear, the rack must always be at the same distance from the gear without major friction points.

DUCATI DRAWING FOR QUICK INSTALLATION

7

7.1

(A) MAGNO 003
Mechanical limit switch

M = Magnet
R = Magnetic detector

7.2

(B) MAGNO 001 Mechanical limit switch

M = Magnet
R = Magnetic detector

8

8.1 Temporary adjustment of the limit switch magnets

(A) Closed gate limit switch

S1 10 cm

M R

(B) Gate open limit switch

S1 10 cm

M R S2

M = Magnet
R = Magnetic detector
S1 = Mechanical stop gate closed
S2 = Open gate mechanical stop

8.2

M R

8.3

M R

9

A

9.A.1 CTH43

mains current
230V 50Hz

9.A.2 CTH46

mains current
230V 50Hz

9.A.3 0 = black
12V = yellow

CTH46
CTH43 (12V)
CTH43V (12V)

Boards in 12V version = powered by transformer
BLACK cable + **YELLOW** cable

230V

9.A.4 0 = black
24V = red

CTH43V (24V)

Boards in 24V version = powered by transformer
BLACK cable + **RED** cable

230V

B

9.B.1 Charge the battery before use

230V

Item: MP037 (optional) battery charger by plug

9.B.2

Fasten the panel SOUTH direction

9.B.3 Board CTH46: solar panel power supply

CTH 46

Battery 12V min.7A

9.B.4 **CMBAT DISPLAY**

Board CTH43V in 12V version: solar power

Solar Panel 12V min 10W

Battery 12V min. 7A

CTH43

DUCATI DRAWING FOR QUICK INSTALLATION

10

10.1

Time Power

10.2

Closed gate

10.3

P1 (LRN)

Press and release button P1 (remote control self-learning)

10.4

Press the button on the remote control to memorize it

11

11.1

To unlock

11.2

Manually open the gate halfway

11.3

to block

12

12.1 Final adjustment of the limit switch magnets

Closed gate limit switch

Gate open limit switch

M = Magnet
R = Reed, sensor
S1 = Mechanical stop end limits in closed position
S2 = Mechanical stop end limits in open position

14 Electronic board CTH46 (12V)

Connections:

- 1** antenna cable.
- 2** antenna ground.
- 3** COM common.
- 3/4** START contact for wired command of the complete opening cycle (NO contact, normally open).
- 4/5** START PED contact for wired pedestrian opening cycle command (NO contact, normally open) the gate will open only 1 m to allow pedestrian passage).
- 6/7** STOP contact to connect an emergency stop button (NC contact, normally closed contact). If there is no connection, keep the contact with the jumper on the board closed. if the contact is open, the operator will stop working until the contact is closed.
- 7** COM common (for photocells and for emergency stop).
- 7/8** Safety photocell NC contact 7 = common, 8 = "FTC" (NC contact, normally closed contact). If there is no connection, keep the contact with the jumpers on the board closed. If the contact has opened the operator during opening, it will close again. And with the gate open, the gate will no longer close until the contact is closed.
- 9** + 12V positive power supply set Photocells.
- 10** Negative photocell kit power supply - 12V.
- 11**+ 12V positive solar panel.
- 12** - 12V negative solar panel.
- 13/14** flashing light 12V max 10W (no polarity to be respected).

Connectors (+/-) for direct connection to 12V min 7A battery / integrated battery recharging system).

- WARNING:** photocell jumper between terminals 7 and 8. Remove only the jumper when connecting a set of photocells.
- WARNING:** emergency stop jumper between terminal block no. 6 and 7. Remove the jumper only when connecting an emergency stop switch.
- WARNING:** Be careful when connecting the battery and solar panel to respect the polarity of the connections:
 - + = + positive = red cable
 - = - negative = black cable / blue
 230V mains power input (non-solar configuration)
 using the toroidal transformer: power the board with the output cables 0 (black) 12V (yellow) with no polarity to be respected.

Buttons:

- P1 = button to memorize remote controls to complete the maneuver cycle.
- P2 = remote control memorization button for pedestrian maneuvering cycle.

Potentiometers:

- TIME** = to choose between step-by-step operation mode (= 0) and timed automatic reclosing.
- POWER** = to adjust the engine power (increase or decrease the sensitivity in case of impact on an obstacle).

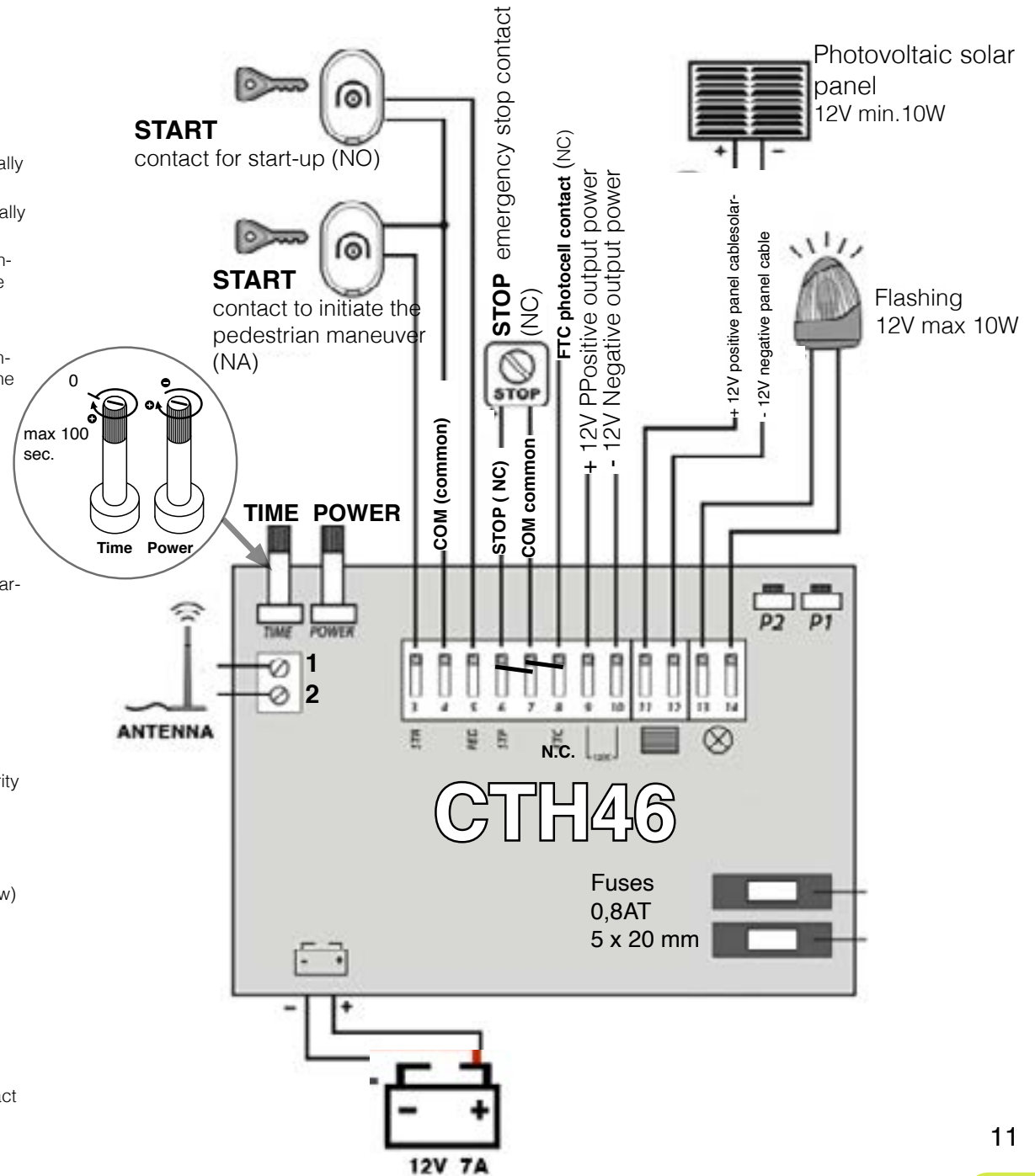

DUCATI CTH43V Scheme of electronic board

15

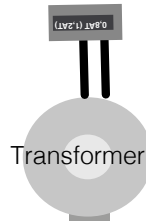
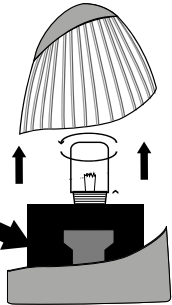
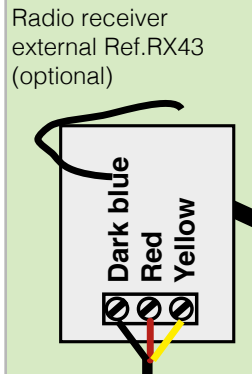

Red = 24 V
Yellow = 12V

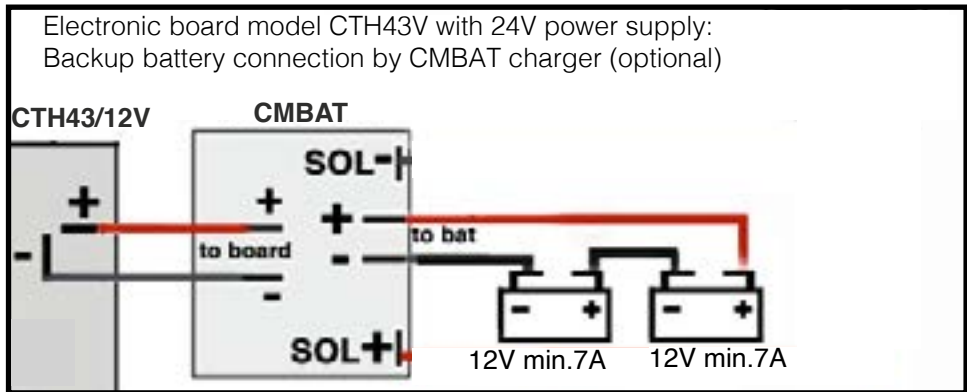
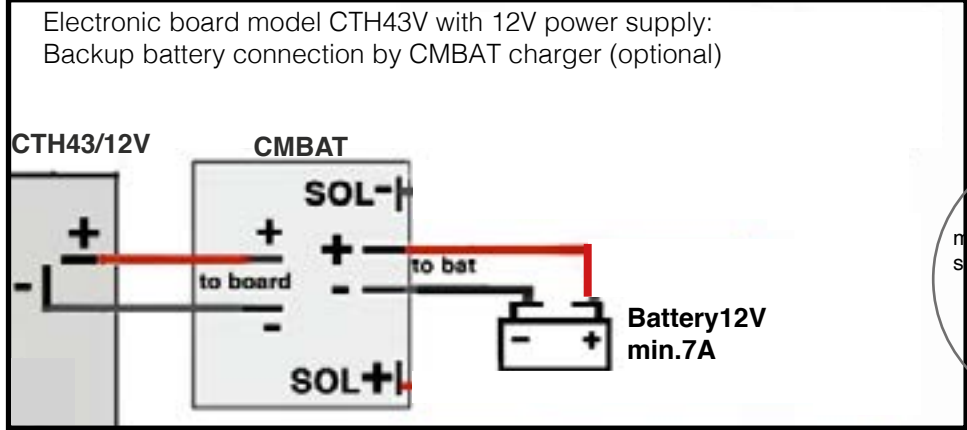
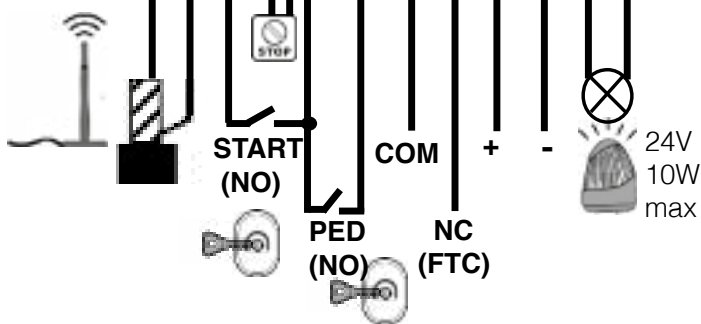
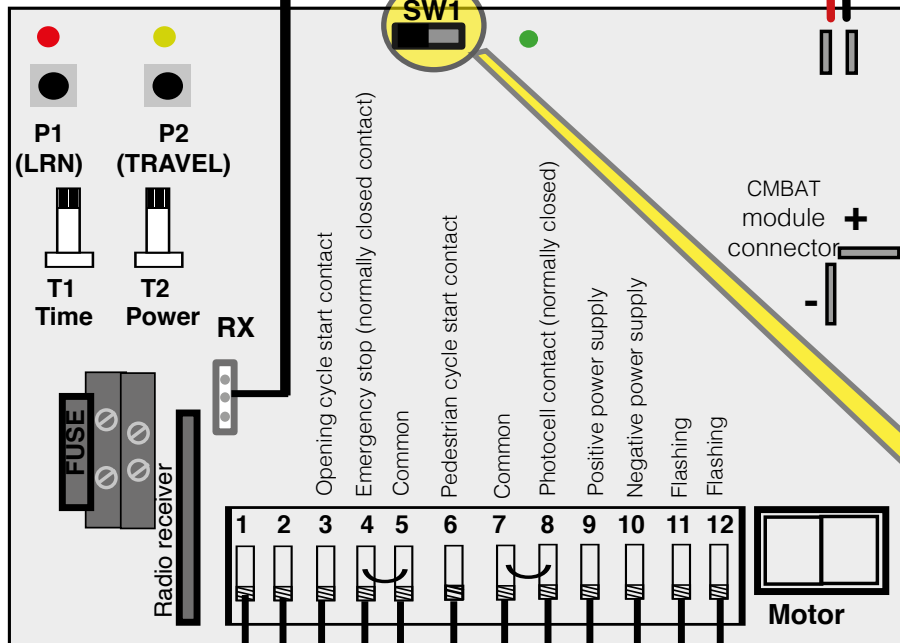
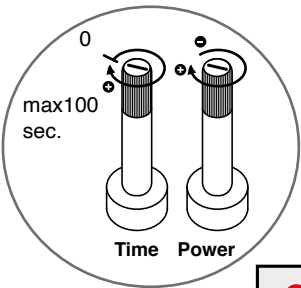

Setting the starting point of deceleration (SOFT STOP)

SW1 Move right to activate the settings (return the switch to the left after completing the setting)

SOFT STOP

press P1 to delay the beginning of the slowdown

press P2 to anticipate the beginning of the slowdown

(1 pulse = 1 second delay / advance)

P1 = -1 sec. P2 = +1 sec.

15

CMBAT DISPLAY

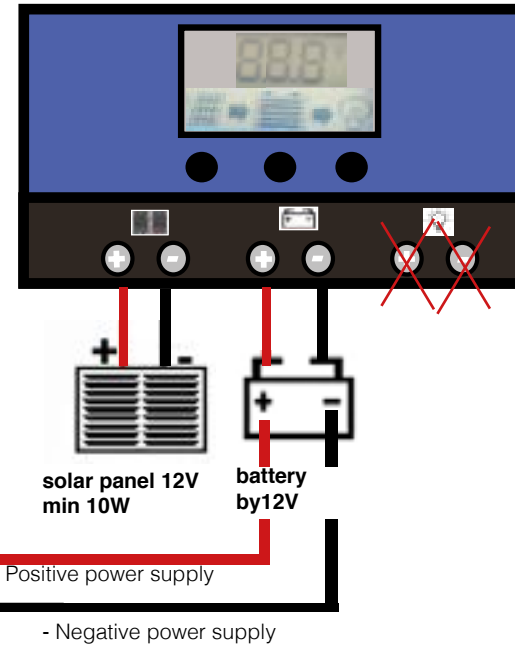
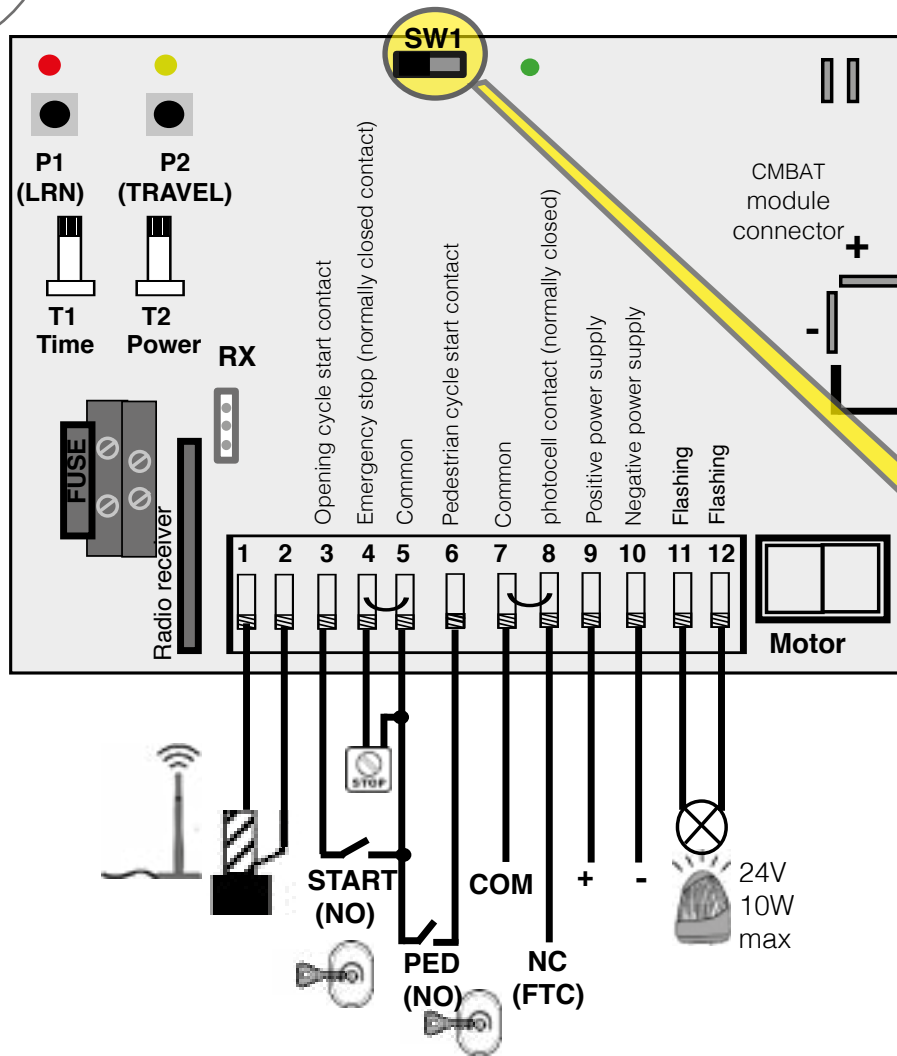
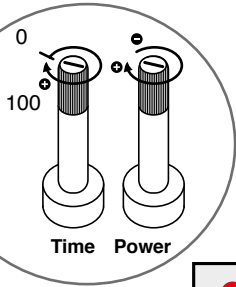

Setting the starting point of deceleration (SOFT STOP)

SW1 Move right to activate the settings (return the switch to the left after completing the setting)

SOFT STOP

press P1 to delay the beginning of the slowdown

press P2 to anticipate the beginning of the slowdown

(1 pulse = 1 second delay / advance)

P1 = -1 sec. **P2 = +1 sec.**

DUCATI CTH43V/24V Electronic board diagram powered by solar panel

15

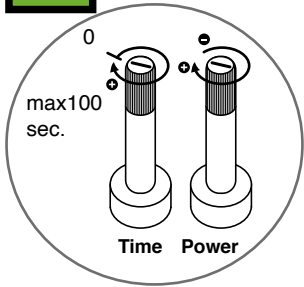

CMBAT DISPLAY

CMBAT DISPLAY

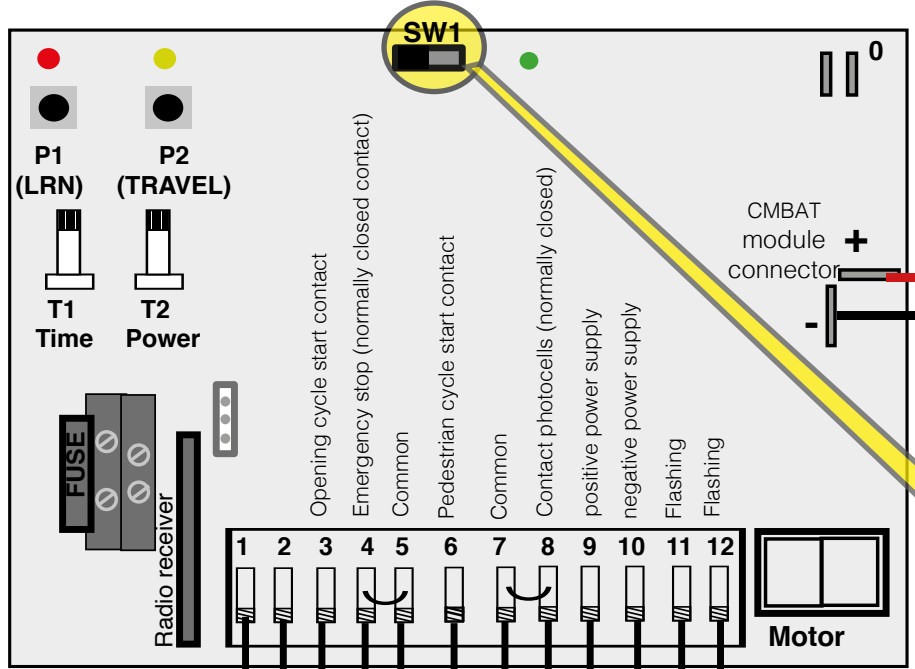
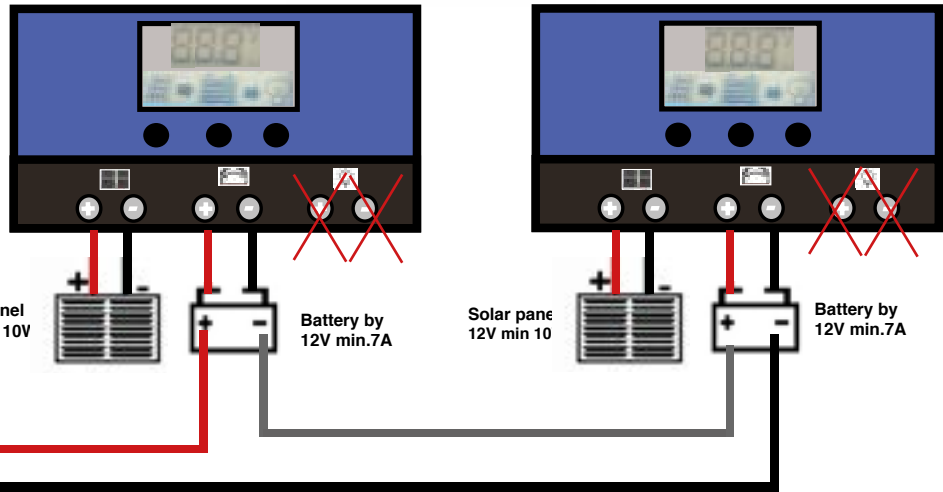

Setting the starting point of deceleration (SOFT STOP)

SW1 Move right to activate the settings (return the switch to the left after completing the setting)

SOFT STOP

press P1 to delay the beginning of the slowdown

press P2 to anticipate the beginning of the slowdown

(1 pulse = 1 second delay / advance)

P1 = -1 sec. **P2** = +1 sec.

Electronic board CTH43

Attention 3 versions of this existing board:

- a) CTH43N version: 12V without SOFT-STOP (double speed with slowdown).**
- b) CTH43V/12V version: 12V with SOFT-STOP.**
- c) CTH43V/24V version: 24V with SOFT-STOP.**

The electrical circuit is the same for the 3 versions. The deceleration setting is not available in the CTH43N version.

Connections:

- 1** antenna cable.
- 2** antenna ground.
- 5 COM** common.
- 3/5 START** contact for wired control of the complete opening cycle (NO contact, normally open).
- 5/6 START PED** contact for wired pedestrian opening cycle control (NO contact, normally open) the gate will open only 1 m for the pedestrian crossing).
- 4/5 STOP** to connect an emergency stop button (NC contact, normally closed contact). If there is no connection, keep the contact with the jumper on the board closed. if the contact is open, the operator will stop working until the contact is closed.
- 7 COM** common (for photocells).
- 8** NC safety photocells "FTC" contact (NC contact, normally closed contact). If there is no connection, keep the contact with the jumpers on the board closed. If the contact has opened the operator during opening, it will close again. and with the gate open, the gate will no longer close until the contact is closed.
- 9** + 12V positive power supply set Photocells.
- 10** Supply of negative photocells set - 12V.
- 11/12** Flashing light 11/12 12V max 10W (no polarity to be respected).

Connectors (+/-) for connection to the optional reference module. CMBAT which allows you to connect a buffer battery and possibly a solar panel. Attention, do not connect a battery directly to the +/- connectors of the CTH43 board!

 **WARNING:** photocell jumper between terminals 7 and 8. Remove the jumper only when a photocell kit is connected.

 **WARNING:** Emergency stop jumper between terminal block no. 4 and 5. Remove the

jumper only when connecting an emergency stop switch.

 **WARNING:** Be careful when connecting the optional battery charger, Modul Ref. CMBAT. respect the polarity of the connections:
CMBAT connector "+ to board" = + positive connector on the CTH43 / CTH43V board.
CMBAT "- to board" connector = negative - connector on the CTH43 / CTH43V board.

SUPPLY 230V:

CTH43/CTH43V BOARD in version 12V:

using the toroidal transformer: power the board with the toroidal transformer output cables: 0 (black) 12V (yellow) no polarity to be respected.

CTH43/CTH43V BOARD in version 24V:

using the toroidal transformer: supply the card with the output cables of the toroidal transformer: 0 (black) 24V (red) with no polarity to be respected.

POWER SUPPLY from solar panel: (12V version boards only)

You need to add a CMBAT module
CMBAT connector "+ to board" = + positive connector on the CTH43 / CTH43V board.
CMBAT connector "- to board" = - negative connector on the CTH43 / CTH43V board.

Buttons:

- P1** = button to memorize remote controls to complete the maneuver cycle.
- P2** = button for memorizing remote controls for pedestrian maneuvering cycle.

Potentiometers:

- TIME** = to choose between step-by-step operation mode (= 0) and timed automatic reclosing.
- POWER** = to adjust the engine power (increase or decrease the sensitivity in case of impact on an obstacle).

WARNING: Adjustment must be carried out with the gate closed.

Slide SW1 switch to the right to access the delay parameter setting function.

DELAY THE SLOW DOWN:

Press button P1 to delay the start of deceleration by 1 second (= approximately 15 cm of travel). Each time you press the yellow LED lights up. When the yellow LED flashes, you are at the end of the possible setting.

ANTICIPATE THE SLOW DOWN:

As before, but use P2 to bring forward the deceleration by 1 second.

IMPORTANT: Once the adjustment is complete, turn the SW1 switch to the left.

Carry out a maneuver to check that the deceleration occurs at least 80-100 cm before stopping the limit switch magnet.



1) PRELIMINARY CHECKS BEFORE INSTALLATION:

- Check that the gate is professionally installed and complies with the safety standards in force in the area, that it is well balanced and equipped with mechanical safety stops that prevent the gate from leaving the tracks, causing serious danger to people and things.
- Check that the gate has the correct dimensions, weight and structure to install this product and that the motor dimensions are compatible with the structure.
- Check that the gate is perfectly squared and that there are no points of friction or obstacles that prevent correct and easy handling. The gate must be moved manually without too much force.
- Check that the track and the sliding wheels are underground in good condition and free of debris that could affect correct movement.
- Check that the flashing light is visible inside and outside the property to take into account an automatic movement of the gate by third parties.

WARNING: important safety tips

A) BEFORE INSTALLATION

Understand the operation and installation of the phases of your automation:

- Read the manual carefully to fully understand its operation and features.
- Check that the automation is suitable for the type, size and weight of your structure.

Check the good condition of your structure:

- Make sure your gate has been installed and is working correctly.
- Check the quality, solidity and stability of the structure.
- Check that the gate to be automated is well balanced, with no more than 2 wheels, that it slides well and that it does not have any friction points when it is opened manually.

Movement must be fluid. The gate must have strong mechanical stops that prevent it from coming out of the rails with the risk of falling on people or things (potential risk of serious injury or death!).

Warning: an engine cannot correct structural failures.

If the gate stops during travel, is altered or defective for other reasons, contact a qualified technician to restore the gate in good condition and before installing the automation structure to avoid any risk of damage or serious injury or death.!

- Before installation, restore the structure and the non-perfectly functioning gate in good condition.

Prevention of Serious Damage, Injury, or Death from Electric Shock:

- Make sure not to connect the 230V power supply before completing the correct installation of the motor (except in the case of a solar panel powered system).
- Do not connect the high voltage power supply before this procedure is indicated in the instruction manual.
- The installation and electrical connections must be carried out in compliance with all current regulations and in full compliance with the safety standards in force in the area.

B) DURING INSTALLATION:

Personal safety recommendation:

- Do not use accessories or clothing that could become entangled in the drive system or in the gate, neither during nor after the installation of the drive, to prevent these objects or components of the structure itself from being trapped. This could cause serious injury or even death from strangulation.
 - Pay attention to each stage of the installation and pay the utmost attention to the safety of people. Make yourself aware and responsible to act to protect your safety and that of others.
 - Do not modify the structure to try to adapt it to the engine. Always check safe and efficient operation and remember that the motor cannot compensate for the defects of a non-compliant structure, limits of use or built without respecting the best rules of the art and with the safety standards in force.
- Prevention of serious damage:**
- Avoid being near areas where there is a risk of pinching your fingers or toes.
 - Do not activate the motorization before checking that there are no people, animals or objects in the maneuvering area. Observe the door throughout the maneuver and check that the area is clear throughout the maneuver cycle.
 - Never leave the control devices within the reach of children and unauthorized persons.
 - Any fixed control device must be installed min. 1.5 m above the ground.

Keep people and children away from areas with a risk of crushing or entrapment. It is advisable to provide protection (often a metal grid is used) to prevent people from approaching the movable gate and to prevent the ends from being trapped in the movable structure.

Prevention of damage to the transmission system:

Remember that two main influencing factors are involved in the motorization of a sliding gate: the weight and the sliding fluidity of the gate: these 2 factors influence the inertia force of the gate, which is the main factor that allows you to evaluate the choice of most suitable engine. A bad evaluation can compromise the correct movement of the door. A very slippery gate will have a high inertial force. For a gate of this type it is advisable to choose a motor with slowdown to guarantee a flexible stop.

The motors of the SLIDE series provide for the stop of the gate by detecting the magnetic limit switches (magnets) that must be placed along the frame. It is very important that the rack is correctly fixed to the gate, leveled and balanced with respect to the motor output gear, to avoid points of greater friction that can hinder the correct movement of the gate.



WARNING: A rack that is not perfectly balanced with the gate and the motor output gear would produce a friction point, detected by the system as an obstacle that will cause the motor to stop for the anti-crushing safety system. Thus preventing the door from moving.

WARNING: Pay particular attention to the correct positioning of the magnetic limit switches, checking that they are intercepted by the controller in front of the gate until the mechanical stop of the structural locks.

- It is advisable to adjust the motor power level to the minimum power necessary for movement, checking the correct functioning of the obstacle detection safety system.

AFTER INSTALLATION:

- Check the correct execution in each phase and check that the gate slides correctly in manual operation, without any point of friction.
- Check that the limit switch magnets are correctly positioned on the frame and that they are detected by the electronic board before the gate touches its mechanical stops.
- Carry out complete opening and closing operations and check that the obstacle detection safety system reacts correctly within the parameters established by the regulations in force in the area.
- Check the defined parameters and functions.
- For systems powered by solar panels, check the state of charge of the battery.
- Ensure the general safety of the motorized structure to avoid accidents causing damage, injury or death.
- Attach a visible and permanent warning to the automatic gate indicating the presence of an automated system.
- Attention, never stop halfway through the travel of the motorized gate when this is activated.

WARNING: be careful when the automatic gate closing function has been activated: in this case the gate could close while someone or something is in the movement area.

MONITOR THE GATE DURING THE DURATION OF THE MOVEMENT

- Never leave anyone unattended near a moving gate, or a partially open or partially open gate. Make sure that no one is in or passes in the movement area during the activation and maneuvering phases.
 - Never allow children or unauthorized persons to play or access control devices. Make sure that mobile and stationary controls are out of the reach of children or unauthorized persons.
 - When closing, do not try to stop the gate with your hands or parts of the body. It can be very dangerous!
- Damage prevention:
- Never leave any object or vehicle, even temporarily, in the gate's maneuvering area.
 - Do not attempt to cross, on foot or with a vehicle, the gate movement area during the maneuver, but always wait until the gate has stopped.
 - Activate the gate only if you can keep a visual check and you have verified that there are no people, objects or animals in the maneuvering area.

Maintenance:

- Perform regular maintenance of the structure to ensure maximum safety.
 - Before carrying out any maintenance or repair operations, disconnect the motor from the power supply.
 - Periodically check the state of the structure and replace the defective parts, solve the faults, check the oxidation or wear of the mechanical parts.
- Pay close attention to checking the door hinges, sliding wheels and rails.

Avoid unauthorized use:

- Protect control systems to prevent unauthorized use.
- Do not install control systems in places where they could have unauthorized access when the gate is activated.

ACCESSORIES AND EQUIPMENT REQUIRED FOR INSTALLATION



To install the engine, you need the following tools:

Drill, rubber mallet, spirit level, screwdriver, spanners, pliers, cable gland sleeve. More, electric cables, concrete to build a base or install the engine.

To fix the frame you need 6mm diameter self-drilling screws, screwdriver to fix the motor to the ground. screws for fixing accessories.

Silicone to seal the passage holes of the motor cable.

Dynamometer to verify the compliance of the mechanism with current regulations.

2) LIMITATIONS OF USE

See the data table for each engine model (page 2-3) and the engine dimensions (drawing on page 5).

Check that the overall dimensions of the motor are compatible with the structure. Check that the weight and length limits of the gate are compatible with the gate.

WARNING: The motorization is designed to motorize professionally installed gates with excellent balance and linear movement without friction. The gate must be well balanced, flat and slide without friction in both directions of travel.

Gates installed not according to the basic safety principles, a structure that does not comply with these standards, cannot be automated. The engine cannot compensate for structural defects. Get your structure up to standard before automating it.

 **WARNING:** The gate must be equipped with mechanical stops that prevent the gate from derailing, causing a risk of serious danger to the life of people or things.

WARNING: In the absence of a mechanical stop, do not automate or manually operate the gate. Call a specialist right away to bring the facility to a standard level. The manufacturer declines all responsibility for damage caused by improper installation of unsuitable or dangerous structures.

PREPARATIONS BEFORE INSTALLATION

Motorization operated by a high voltage sector: A certified electrician must prepare the 230V 50Hz (or 110V 60H) power supply line with cable outlet at the point where the motor will be earthed (procedure not necessary in case of motorization from solar panel).

The surface on which the engine will be fixed to the ground must be perfectly smooth and flat. It is advisable to arrange a higher floor from the ground to avoid possible water infiltration, for example a masonry, concrete or iron base. It is also advisable to add the plate Ref. PLAK 7800 as an option, which allows a better adjustment of the final position of the motor with respect to the rack. This optional accessory facilitates the correction of the position that may be necessary over time or in relation to the change of season due to the expansion of the materials in relation to the temperature.

The height of the surface where the motor is to be fixed must also be studied in relation to the position of the frame that will be installed on the gate.

Prepare sheaths for the passage of the accessory connection cables (flashing light, key selector and possible set of photocells, external receiver).

3) ENGINE POSITIONING: RIGHT OR LEFT

(See the drawings in section 3, page 6).

The motor must be installed parallel to the gate. Inside the property at the level of the column corresponding to the side on which the gate opens.

It is important to calculate the mounting position of the motor over the distances indicated within the limits of drawing 4.2, on page 6.0.

MOTOR CABLE CONNECTION depending on the direction of movement of the gate: gate that opens to the right or opens to the left (seen from inside the property).

The motor is designed for a STANDARD opening of the gate on the right (seen from inside the property). Illustration 3.2.

If the gate opens to the left it is necessary to reverse the polarity of the red and blue

motor cables, taking care not to damage the support of the brush holder blades. drawing 3.3.

4) ENGINE ASSEMBLY

(See the drawings in section 4).

The surface on which the engine will be fixed to the ground must be perfectly smooth and flat. It is advisable to arrange a higher floor from the ground to avoid possible water infiltration in case of cold. It is also advisable to add the optional plate Ref. PLAK7800, which allows a better adjustment of the final position of the motor with respect to the rack. This optional accessory facilitates the correction of the position that may be necessary over time or in relation to the change of season due to the expansion of the materials in relation to the temperature. The height of the surface where the motor is to be fixed must also be studied in relation to the position of the frame that will be installed on the gate.

After having determined the ideal mounting position of the motor and its height with respect to the frame, fix the motor directly to the ground using screws suitable for the type of floor (not included). Drawings 41-4.2.

In case of using the additional plate Ref. PLAK8700, fix the plate to the ground and then fix the motor to the plate using the supplied screws that allow you to adjust the exact final position with respect to the rack. It is recommended to use screws to position the motor in the high position. Figure 4.3.

Over time, the progress of the structure tends to decrease. It will then be possible to adapt the motor correction downwards.

5) MANUAL EMERGENCY RELEASE

(See the drawings in section 5).

The key release system allows the gate to be operated manually.

Two release keys are provided.

Turn the key clockwise, pull the knob towards you. The gate can now be moved manually.

To re-lock the engine, close the release knob, turn the key counterclockwise, and remove the key in the vertical position. drawing 5.1.

Note: the release system is only accessible from inside the property. It is recommended that you make sure you have secondary access.

6) FIXING FROM THE RACK TO THE GATE

(See the drawings in section 6).

The rack (module 4) can be supplied as standard Ref. RACK 8612 in Hostaform® (special material in acetal copolymers showing a remarkable combination of wear resistance, long-term fatigue resistance and hardness) in measuring sections of 0,5 m each or, on request, in the traditional iron version (Art. FE8612) in 1 m bars.

Perfect alignment of the frame is of the utmost importance and determines the correct movement and operation of the drive.

WARNING: a rack not perfectly aligned with the gate would produce a friction point, detected by the motorization as an obstacle detected by the safety system which will cause the motor to stop.

Fastening of the rack model RACK 8612:

Once the motor has been fixed (make sure to respect the correct distance between the motor and the gate, see drawing 6.4), the frame must be installed one section at a time (drawing 6.5).

Each segment must be fixed individually to the rack by sliding the gate and checking that the height of the rack with respect to the motor output pinion is always at the same distance (drawing 6.2 - 6.3) pag. 7.

WARNING: respect the tolerance of the dimensions indicated in the drawings in step 6 on page 7.

Proceed as follows:

- 1) Unlock the motor and manually open the gate up to the mechanical stop.
- 2) Place the first piece of rack (0.5 m) on the motor output pinion, at the correct distance and height.
- 3) Mark the top line of the grid and the position of the holes on the gate with a special pencil.
- 4) Fasten the first section of the frame to the gate with self-drilling screws.
- 5) Proceed in the same way with the other sections of the grid until it is fixed along the entire length of the gate. Take care to position each piece of rack at the same height so that the distance between the motor output pinion is constant over the entire length of the gate.

The rack must be fixed to the gate with self-drilling stainless steel screws (not included).

Assemble the rack parts using the male-female recessed bracket using a rubber mallet.

WARNING: Once finished, manually move the gate and check that it slides smoothly along its length without showing any friction points. If not, correct the attachment of the rack.

6) restart the engine (see section 5).

7-8) PRE-POSITIONING OF LIMIT SWITCH MAGNETS ON THE HINGE.

(section 7 and 8 drawings on page 8).

The position of the magnets along the frame determines the stop point of the gate in both directions of travel. The limit switch magnets must be fixed on the frame (drawings section 7) and must be detected by the operator, before the gate reaches the mechanical stop on the structure.

NOTE: To avoid an error in the positioning of the magnets, it is recommended, at this stage of the installation, to pre-position the magnets well before the final mechanical stop of the gate and subsequently postpone the precise positioning of the magnets. How to pre-position the limit switch magnet for the gate closed position.

- 1) Unlock the motor.
- 2) Manually position the gate 10 cm before the completely closed position.
- 3) Manually move the limit switch magnet (M) and align it with the "Reed" magnet detector (R), the position of which is indicated on the motor cover by a label (R).
- 4) Check that the yellow led on the edge of the electronic board is on to confirm that the magnet has been detected correctly.

Repeat the operation to position the limit switch magnet for the closed gate position:

- 5) Unlock the motor.
- 6) Manually position the gate 10 cm before the gate is completely open.
- 7) Manually move the limit switch magnet (M) and align it with the "Reed" magnet detector (R), the position of which is indicated on the motor cover by a label (R).
- 8) Check that the yellow LED on the edge of the electronic board is on to confirm that the magnet has been detected correctly.

NOTE:

The motorization can be powered by one of the two versions of magnets: MAGNO 001 or MAGNO 003 (see drawings in section 7).

The motorization can be supplied at the choice of the manufacturer, with one of the 2 magnet models available:

- The MAGNO 001 version is supplied with a support inserted along the rack;
- The MAGNO 001 version is supplied with a support that must be fixed directly to the rack (see drawing in section 8, on page 8).

9) POWER SUPPLY (drawings from section 9.A on page 9).

A) SUPPLY BY SECTOR



**230V / 50Hz high voltage power connection
(or 110V / 60HZ on request)**



WARNING DANGER!

Connection to the high voltage power supply is extremely dangerous (risk of death from electric shock) and must only be performed by a qualified and certified electrician. Only an electrician with the necessary skills and certifications can be authorized to fasten the high voltage power cord and connect it to the fused terminal before the supplied transformer.

Drawings in point 9.A.

After connecting the power supply, check that the green LED on the electronic board is on = clear presence.

If the green light is off, check the protection fuse and replace it if necessary. Fuse T0.8A 250V 5 x 20.

B) POWER SUPPLY FROM SOLAR PANEL (drawings in section 9.B) page 9.

In this power supply mode, (only for 12V version) 100% autonomous, no connection to the 230V network is necessary. If, on the other hand, it is rechargeable, it is also possible to connect to the 230V network at the same time, but with a switch, to have an alternative power source in case the battery is flat and to be able to recharge easily.

WARNING: Before proceeding, the battery must be fully charged for a period of 16 hours, or until it is fully charged. To charge the battery it is recommended to use a 12V power supply with optional accessory charge control Ref. MP036. The battery can also be charged by the toroidal transformer. Connect the battery to the plate according to the specific scheme for each model and connect a power socket to the terminal blocks before the transformer. Then plug it into a power outlet.

The motorization model SLIDE 446 / SLIDE 446 SOLAR is supplied with the electronic board model CTH46 specially designed for powering by solar panel with energy

saving system (only 0.007A in stand-by) which guarantees a long autonomy. The management of the battery charge and the solar panel are already integrated on board. The connection of the solar panel of the 12 V battery must be made directly on the CTH46 board (see drawings 9.B.1 and 9.B.2, page 9).

The 12V solar panel charges the 12V battery. The drive is powered by the energy stored in the battery. A charge control system regulates energy savings and prevents overnight discharge. Connect the battery and the solar panel directly to the CTH46 board (diagram on page 11 and instructions on page 20).

WARNING: Observe the polarity of the connection!

The SLIDE743 SOLAR (12V) motorization is supplied with the CTH43V (12V) electronic board and the CMBAT charger in a specific configuration for energy from solar panels. In this electronic board, the power consumption in standby mode is 0.012A. Connect the batteries in series, connect them to the CMBAT module, connect the CMBAT module to the CTH43V / 24 electronic board.

Warning: respect the polarity of the connection as indicated in drawing 9.B.3 / diagram on page 12-13 and instructions on p. 22-23.

The solar panel must be fixed to the wall with the pole or bracket provided (drawing 9.B.2) and be facing south (facing the sun at noon) away from any shade. Periodically clean the panel from dirt, leaves, snow that could hide and compromise its functionality.

The greater the exposure of the panel to sunlight, the greater the level of energy accumulated for day.

To obtain greater autonomy, it is possible to increase the power of the solar panel, or add additional solar panels. The ampere (A) capacity of the battery should be compared with the size of the solar panel to ensure ideal energy storage.

Example: 12V 7A battery with 12V 10W solar panel;

12V 12A battery with 12V 20W solar panel to increase the level of autonomy.

10) HOW TO STORE THE REMOTE CONTROL TO DIRECT THE FIRST OPERATION (drawings in section 10)

Attention: the remote controls supplied with the kit are normally already memorized with the board for their motorization (remote control button at the top left, memorized by the manufacturer for the total maneuver cycle).

How to memorize a remote control:

Attention, check that:

- The gate must be closed on the limit switch magnet. Check that the yellow LED on the electronic board is on.
- Check that the gate is in "step by step" operating mode = "TIME" potentiometer turned anticlockwise to position = zero.
- Check that the motor power is set to maximum. = "POWER" potentiometer completely turned timeless.

See diagram 14 for the CTH46 board and diagram 16 for the CTH43V / 24 board.

Each button on the remote control corresponds to a broadcast channel. The button to be used to control the motor must be stored in the memory of the motorization electronic board.

10.1) REMOTE CONTROL MEMORIZATION

(see also the remote controls chapter).

- On the electronic board, press the P1 key.
- The red LED light turns on.
- Release the P1 key.
- Press the remote control button (hold it down for a few seconds) that you have chosen to control the performance.
- The red LED on the electronic board flashes briefly to confirm storing the code.
- Procedure completed.

10.2) FIRST OPERATION:

- Unhook the gate and manually position it halfway (the gate must be positioned halfway between the magnet of the two limit switches).
- Close the gate again.
- Press the button of the previously memorized remote control.
- Wait for the portal to perform the first one manually.
- Check that the gate stops as soon as it intercepts the limit switch and that the yellow LED lights up.

WARNING: If the gate does not stop at the limit switch magnet, the gate will lock into the mechanical stop of the frame. The mechanical stop will be identified as an obstacle.

It will be necessary to correct the position of the motor by reducing the distance from the motor to the rack so that the magnet is correctly detected by the electronic board (and then the yellow LED lights up to confirm it).

11) FINAL POSITION OF THE LIMIT SWITCH MAGNETS

To identify the final fixing position of the limit switches, open the opening and closing cycles, taking care to move the magnets a few centimeters at a time, bringing them closer and closer to their final position.

In this way it will be possible to perfectly fit the magnets. Check that the gate stops correctly in the desired position, both in opening and closing.

WARNING: It is absolutely necessary to pay maximum attention to the correct positioning of the limit switch magnets. Check that the gate does not protrude from the magnet striking the mechanical stop.

Basic installation is complete!

Follow the instructions for connecting accessories and adjustments corresponding to the engine model.

12) ELECTRICAL CONNECTIONS:

See the connection diagrams corresponding to your electronic board model on the following pages.

DUCATI ELECTRICAL CONNECTIONS / BOARD SETTINGS CTH46



12.1) ELECTRONIC BOARD CTH46 (see page 11)

Three feeding methods:

- a) by switch 230V (110V or on request).
- b) sector + buffer battery for energy autonomous in case of power failure.
- c) from 12V solar panel at least 10W and 12V battery min. 7A (see chapter 9B) 100% energy autonomy.

Connections:

- 1** antenna cable.
- 2** antenna ground.
- 3 COM** common.
- 3/4 START** contact for wired control of the complete opening cycle (NO contact, normally open).
- 4/5 START PED** contact for wired pedestrian opening cycle command (NO contact, normally open) the gate will open only 1 m for the pedestrian crossing).
- 6/7 STOP** contact to connect an emergency stop button (NC contact, normally closed contact). If there is no connection, keep the contact with the jumper on the board closed. if the contact is open, the operator will stop working until the contact is closed.
- 7 COM** common (for photocells and for emergency stop).
- 7/8** Contact "FTC" NC safety photocells (NC contact, normally closed contact). If there is no connection, keep the contact with the jumpers on the board closed. If the contact has opened the operator during opening, it will close again. and with the gate open, the gate will no longer close until the contact is closed.
- 9** + 12V positive photocell power supply set.
- 10** - 12V negative photocell power supply set.
- 11** + 12V positive solar panel.
- 12** - 12V negative solar panel.
- 13/14** flashing light 12V max 10W (no polarity to be respected).

Connectors (+/-) for direct connection to 12V min 7A battery / integrated battery recharging system.

WARNING:

Terminal blocks 6/7 are connected by an electric jumper to keep the emergency STOP contact closed. Remove the jumper only if a switch is connected to command an emergency stop. If the contact is open, the gate will not work at all until the contact closes.

WARNING:

Terminal blocks 7/8 are connected by an electric bridge to keep the photocell contact closed. Remove the bridge only if the photocells are connected. If the contact is open, the gate will open but will not close.

POWERED BY BATTERY / SOLAR PANEL:

CABLES welded into the connectors (+/-) for connecting a 12V min 7A battery
Attention: respect the polarity of the connection.

red wire = + positive; blue (or black) wire = - negative.

Solar panel: positive on terminal block # 11 and negative on terminal block # 12. Pay attention to respect the polarity!

The reduced stand-by consumption of only 0.007A allows an autonomy of up to 50 operations / day with 12V 7A panel and 12V 10W battery.

Position the panel no more than 10 m from the map in the SOUTH direction.

The panel must be in full sun.

POWER SUPPLY 230 V AC:

Transformer wire input terminal block: 0 = black wire; 12V = yellow.

Connect the transformer to the board in the case of 230V sector power supply or to recharge the battery if necessary.

Buttons:

P1 = Button for memorizing the remote control codes to command a total maneuver cycle. The same button is used to clear all codes for all previously stored remote controls.

P2 = Button to memorize the remote control codes to order a partial maneuvering cycle to allow only the passage of pedestrians (partial opening of about 1 m).

MEMORY STORAGE OF THE REMOTE CONTROL IN THE MEMORY OF THE ELECTRONIC BOARD:

WARNING: the gate must be closed.

a) Memorizes a button to command a complete maneuver cycle

- On the electronic board, press the P1 key.
- The red LED light will turn on.
- Release the P1 key.
- Press the button on the remote control (hold it for a few seconds to sort the performance).
- The red led on the electronic board flashes briefly to confirm the memorization of the

code. Procedure completed.

b) Memorize a button to command a partial maneuver cycle for pedestrian access

Follow the procedure from point a) but using the P2 key instead of P1 (electronic boards CTH43V / 24 and CTH46).

WARNING: The memory of the electronic board can store up to 20 channels. If you need more memory capacity, you can add a RIXY6040 or RIXI 6043 external radio receiver.

CLEAR THE MEMORY OF THE ELECTRONIC CARD:

Erase the memory of the electronic card (this operation will result in the total loss of the remote control codes in memory).

If the memory card is full or if a transmitter has been lost, it is possible to clear the memory on the electronic card. ATTENTION: the gate must be closed.

- On the electronic board, press the P1 key and keep it pressed for about 30 seconds.
- The red LED will light up, once the memory is cleared, the red LED will flash to confirm that the operation has been performed correctly.
- Release the P1 key. Procedure completed.

POTENTIOMETERS:

POTENTIOMETER T1 (TIME) = This potentiometer allows you to choose between "step by step" operating mode (1 impulse to open and 1 impulse to close the gate) or operating mode with timed automatic closing.

- "STEP BY STEP" operating mode (impulse to open and impulse to close the gate). Each remote control impulse corresponds to a single operation with the sequence: open-stop-close. To set this operating mode, turn the TIME knob fully counterclockwise.

- TIMED AUTOMATIC CLOSING mode (1-100 seconds). Each remote control pulse corresponds to a complete maneuver cycle: opening-pause time during which the gate remains open-and closes automatically. To set this operating mode, turn the TIME knob clockwise. The more turns, the longer the pause time will be up to a maximum of 100 seconds.

POTENTIOMETER T2 (POWER)

= This potentiometer is used to adjust the motor and sensor power. For more details, see chapter 13.2.

ENGINE POWER ADJUSTMENT:

The "POWER" potentiometer / trimmer allows you to adjust the motor power and the sensitivity to detect a possible obstacle during the run.

Turning the potentiometer clockwise increases the motor power and, at the same time, reduces the sensitivity of obstacle detection in case of impact with the moving gate.

LED SIGNALING:

Green led on = 230V sector powered motor.

Yellow / orange LED on = limit switch magnet detected.

Red LED on with door open = signals that the board recognizes that the gate is in the gate open position in step-by-step operating mode.

Red LED flashing when the gate is open = signals that the board recognizes that the gate is in the gate open position in automatic closing operating mode (it flashes until the automatic closing maneuver starts).

Red LED lit by pressing button P1 = indicates that the board is in self-learning mode with remote controls. This mode is active as long as the red LED stays on.



ELECTRONIC BOARD CTH43

Attention there are 3 versions of this board:

- a) **CTH43N 12V version.**
- b) **CTH43V/ 12V version:** with SOFT-STOP.
- c) **CTH43V/24V version:** with SOFT-STOP.

The electrical circuit is the same for the 3 versions.

The deceleration setting is not available in the CTH43N version.

Connections:

- 1 antenna cable.
- 2 antenna ground.
- 5 COM** common for emergency stop and start contact operated by hardwired "Start". START 3/5 contact for wired command of the complete opening cycle (NO contact, normally open).
- 5/6** START PED contact for wired pedestrian opening cycle control (NO contact, normally open) the gate will open only 1 m to allow pedestrian passage.
- 4/5 STOP** contact to connect an emergency stop button (NC contact, normally closed contact). If there is no connection, keep the contact with the jumper on the board closed. If the contact is open, the operator will stop working until the contact is closed.
- 7 COM** common (for photocells).
Contact "FTC" NC safety photocells (NC contact, normally closed contact). If there is no connection, keep the contact with the jumpers on the board closed. If the contact has opened the operator during opening, it will close again.
and with the gate open, the gate will no longer close until the contact is closed.
- 9** + 12V positive photocell power supply set.
- 10** - 12V negative photocell power supply set.
- 11/12** flashing light 12V max 10W (no polarity to be respected).

WARNING: photocell jumper between terminals 7 and 8. Remove the jumper only when a series of photocells is connected.

WARNING: Emergency stop jumper between terminal block # 4 and 5. Remove the jumper only when connecting an emergency stop switch.

Connectors (+/-)

For connection to the optional module Ref. CMBAT which allows to connect a buffer

battery and possibly a solar panel.

Be careful not to connect a battery directly to the +/- connectors of the CTH43 board!

WARNING: For the CTH43 / 24V version board, with buffer battery, using only a 12V min 7A battery, the motorization can only operate at low speed in the event of a power failure. It is recommended to use 2 12V batteries connected in series to power the 24V motor correctly and allow it to function correctly even in the event of a power failure.

WARNING: For the CTH43 / 12V version board with CMBAT module it is possible to power the motorization also by a 12V min 10 W solar panel combined with 112V min battery 7A.

POWER SUPPLY 230V:

CTH43 / CTH43V in 12V version:

using the toroidal transformer: power the board with the toroidal transformer output cables: 0 (black) 12V (yellow) no polarity to be respected.

CTH43V in 24V version:

using the toroidal transformer: supply the card with the output cables of the toroidal transformer: 0 (black) 24V (red) with no polarity to be respected.

POWER SUPPLY from solar panel: (12V version boards only)

You need to add a CMBAT module.

CMBAT connector "+ to board" = + positive connector on the CTH43 / CTH43V board.
CMBAT "- to board" connector = negative - connector on the CTH43 / CTH43V board.

Buttons:

P1 = Button for memorizing the remote control codes to command a total maneuver cycle. The same button is used to clear all codes for all previously stored remote controls.

P2 = Button to memorize the remote control codes to order a partial maneuvering cycle to allow only the passage of pedestrians (partial opening of about 1 m).

WARNING: All adjustments must be made with the gate closed and will only take effect in the next cycle.

POTENTIOMETERS:

T1 (TIME) = This potentiometer allows you to choose between "step by step" operating mode (impulse to open and impulse to close the gate) or operating mode with timed automatic closing.

For more details, see chapter 13.1.

OPERATING MODE

The "TIME" potentiometer / trimmer allows you to define two operating modes:

- "STEP BY STEP" operating mode (impulse to open and impulse to close the gate). Each remote control impulse (always use the same remote control button) corresponds to a single operation with the sequence: open-stop-close. To set this operating mode, turn the TIME knob fully counterclockwise.

- TIMED AUTOMATIC CLOSING mode (1-100 seconds). Each remote control pulse corresponds to a complete operating cycle: pause-opening time during which the gate remains automatically open-closed. To set this operating mode, turn the TIME knob clockwise. the more you turn, the longer the pause time will be up to a maximum of 100 seconds.

T2 (POWER) =The "POWER" potentiometer / trimmer allows you to adjust the motor power and the sensitivity to detect a possible obstacle during the run.

Turning the potentiometer clockwise increases the motor power and, at the same time, reduces the sensitivity of obstacle detection in case of impact with the moving gate.

The power / sensitivity level must be adjusted according to the weight and the sliding level of the gate. Use the minimum power required. Seasonal changes can cause a variation in friction and therefore it is necessary to periodically adjust the power.

Deceleration phase setting (only for CTH43V and CTH43V / 24V version board).

WARNING: It is essential that the gate starts to slow down long before recognizing the limit switch magnet.

WARNING:The exact adjustment of the slowdown is particularly important in the case of very heavy and / or very sliding gates, to manage the force of inertia and

allow a flexible stop.

The card is supplied with slow start 7 seconds after the start of the race. The gate will have traveled about 1.5 m. Depending on the length of the gate, this parameter can be advanced or postponed.

The SW1 switch allows you to enter the setting mode of the point where the engine starts to cool.

If the deceleration is set too close to the magnet, the pushing force due to the inertial force could cause the limit switch to be exceeded. This would cause a malfunction. Therefore, it is recommended to set the start of deceleration to approximately 80-100cm before the motor detects the end-of-stroke magnets.

WARNING: When the season changes and the temperature changes, it may be necessary to adjust the start of deceleration.

To delay or anticipate the slowdown, proceed as follows:

WARNING:Adjustment must be carried out with the gate closed.

Slide SW1 switch to the right to access the delay parameter setting function.

DELAY THE SLOW DOWN:

Press the P1 key to delay the start of deceleration. Each press of the P1 button delays the start of deceleration by one second. (1 second corresponds to about 15 cm of travel).

Each time you press the yellow LED lights up.

ANTICIPATE THE SLOW DOWN:

Press button P2 to anticipate the start of deceleration. Each press of the P2 button anticipates the start of deceleration by one second.

(1 second corresponds to about 15 cm of travel).

Each time you press the yellow LED lights up.

IMPORTANT: When the setting is complete, set the SW1 switch to the left.

Carry out a maneuver to check that the deceleration occurs at least 80-100 cm before the sudden stop of the limit switch magnet.

DUCATI REMOTE CONTROLS ROLLING CODE DUCATI

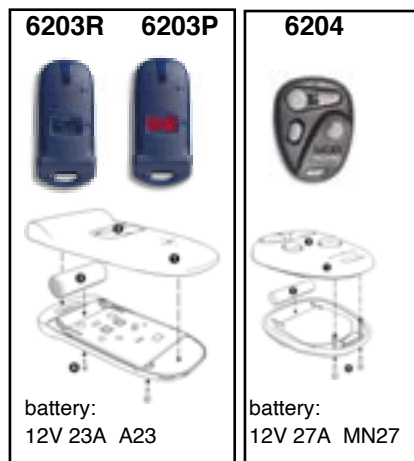

The rol 6203R, 6203P and 6204 models are remote controls DUCATI rolling code.

Model **6203R**...Remote controls with 2 transmission channels. Maximum range 50m
Model **6203P**...Remote controls with 2 transmission channels. Maximum range 100m
Model **6208**...Remote controls with 4 transmission channels. Maximum range 30m
Model **6202**...Remote controls with 2 transmission channels. Maximum range 30m

With over 3 billion combinations, the DUCATI rolling code radio protocol offers maximum protection against radio interference and duplication.

Each button on the transmitter is factory programmed with a unique radio code that corresponds to a transmission channel. Each button can be used to control a different function or a different DUCATI engine.

With the addition of an external DUCATI Rolling Code radio receiver (Ref. RIXY 6040 or RIXY 6043 with display), you can also control other instruments, using the same Ducati remote control.

Each button must be memorized (synchronized) on the electronic board of its motorization in order to be able to control it.

MEMORY STORAGE OF THE REMOTE CONTROL IN THE MEMORY OF THE ELECTRONIC BOARD:

WARNING: the gate must be closed.

a) Memorizes a button to command a complete maneuver cycle

- On the electronic board, press the P1 key.
- The red LED light turns on.
- Release the P1 key.
- Press the button on the remote control (hold it down for a few seconds).
- The red LED on the electronic board flashes briefly to confirm the memorization of the code. Procedure completed.

b) Memorize a button to command a partial maneuver cycle for pedestrian access

Follow the procedure in point a) but using the P2 key instead of P1.

WARNING: The electronic board memory can store up to 10 channels for the CTH43 model and 20 channels for the CTH46 model.

If you need more memory capacity, you can add a RIXY6040 or RIXI 6043 external radio receiver.

CLEAR THE MEMORY OF THE ELECTRONIC BOARD:

Erase the memory of the electronic board (this operation will result in the total loss of the remote control codes in the memory). In the event that the memory board is full or when a transmitter has been lost, it is possible to delete the memory of the electronic board.

WARNING: the gate must be closed.

- On the electronic board, press the P1 key and keep it pressed for about 30 seconds..
- The red LED will light up, once the memory is cleared, the red LED will flash to confirm that the operation has been carried out correctly.
- Release the P1 key. Procedure completed.



DUCATI RADIO KEYPAD ROLLING CODE DUCATI SW6500/TASTY

- Radio keypad SW6500/TASTY 6500 powered by 2 lithium batteries CR2450 3V.
- The keyboard is used to operate the radio frequency automation. The transmission of the radio signal is protected by a customized 4-digit code.

Fix the keypad at a maximum distance of 10 m from the automation control units, 1 radio transmission channel. Prepared for outdoor use.

The radio signal must be memorized in the motorization electronic board with the same procedure indicated for the remote controls (see previous page).

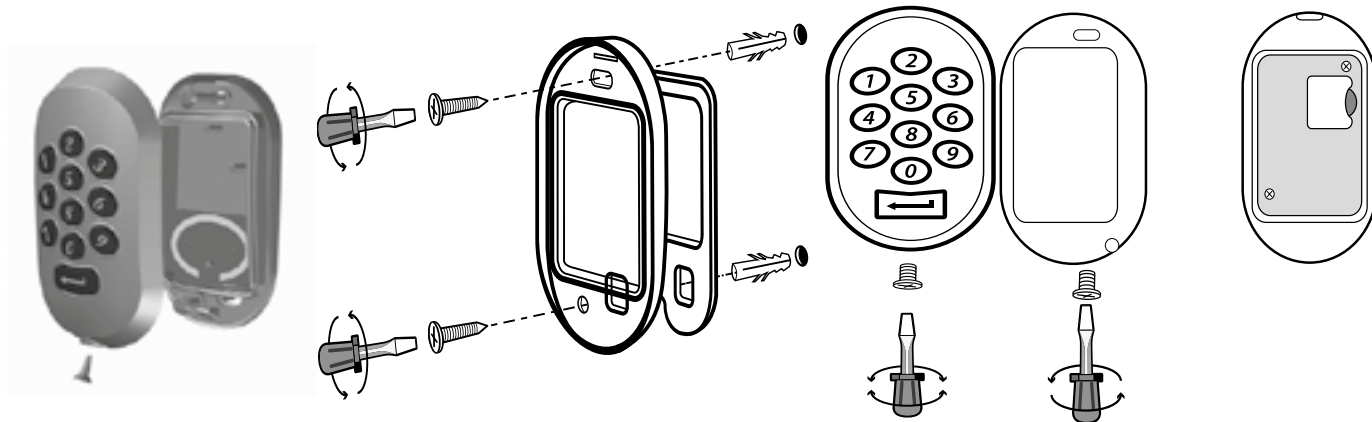

WARNING: Once a personal code has been entered, it is advisable to write it down in order to memorize it since in case of loss it will be impossible to reset the keyboard without returning it to the manufacturer.

WARNING: with an incorrect activation code 3 times the keypad enters security mode and will be unusable for 10 minutes. Wait 10 minutes and enter the correct code.

WARNING: write the code digit by digit slowly.

The keypad is supplied with a standard activation code = 1111. The standard code must be replaced by a personalized secret code.

1) CHANGE THE STANDARD CODE WITH A PERSONAL SECRET CODE

Enter on the keypad the standard code 1111 + key 3 + the new 4-digit personal secret code + the OK key (right side of the key with the arrow / OK). The keypad beeps to confirm the operation. The standard code 1111 is automatically deleted.

2) SAVE THE KEYBOARD TRANSMISSION CHANNEL ON THE ELECTRONIC MOTOR BOARD

- On the electronic board, press the P1 button to command a complete maneuver cycle (or P2 on the CTH43 board and CTH46 board to command a partial pedestrian opening cycle). The red LED light will turn on. Release the P1 key; On your keyboard, type your custom code + OK button.
- The red led on the electronic board flashes briefly to confirm the memorization of the code. Procedure completed.

3) REPLACE A CUSTOM CODE WITH A NEW CODE

On the keypad, enter your custom code + the 4 key + the new 4-digit personal secret code + the OK button. The keypad beeps to confirm the operation.

4) ADD A CUSTOM CODE (WITHOUT DELETING THE PREVIOUS)

On the keypad, enter your custom code + 3 key + new 4-digit personal secret code + OK button. The keypad beeps to confirm the operation.

5) CLEAR CODES (this operation clears all custom codes):

On your keyboard, type your custom code + the 6 key + the OK button. The keyboard LED is flashing, touch the OK button again while the LED is flashing.

WARNING: After this operation the keypad will resume the standard code = 1111, but it will not be possible to command the gate before entering a new customized code following the steps in point 1.

WARNING: To delete a radio keypad from the memory of the electronic board, it is necessary to delete all its memory with the total loss of all previously memorized remote controls. On the electronic board, press the P1 key and keep the key pressed for about 30 seconds.

- The red LED will light up, once the memory has been deleted the red LED will flash to confirm that the operation has been carried out correctly.
- Release the P1 key. Procedure completed.

DUCATI KEY SELECTOR

It is used to command the opening or closing of the gate.

The key selector must be connected to the "START" or "PEDESTRIAN START" contact of the motorization electronic board. Use a 0.5 mm² bipolar cable. No polarity to respect.

Installation:

- 1- Unscrew the fixing screw.
- 2- Choose the desired position and identify the points to drill.
- 3- Fix to the wall using screws and plugs (not supplied), remembering to pass the power cable (not supplied, 0.5mm² recommended) through the cable passage and reposition the sealing gasket.
- 4- After connection (see connections section) replace the cover on the key switch and screw the plug.

Electrical connection

- 1 – Connect the two wires of the power cable to the screw terminals. (Diagram 4).
- 2 – Close the box (diagram 2).
- 3 – Pull the cable from the key switch to the electronic board of your engine.
- 4 – Connect the cable to the relative terminal blocks specified in the general wiring diagram in the manual of the automatic door. (see contact "HOME" or "PEDESTRIAN HOUSE").

Note: polarity does not matter.

■ KEY 5000

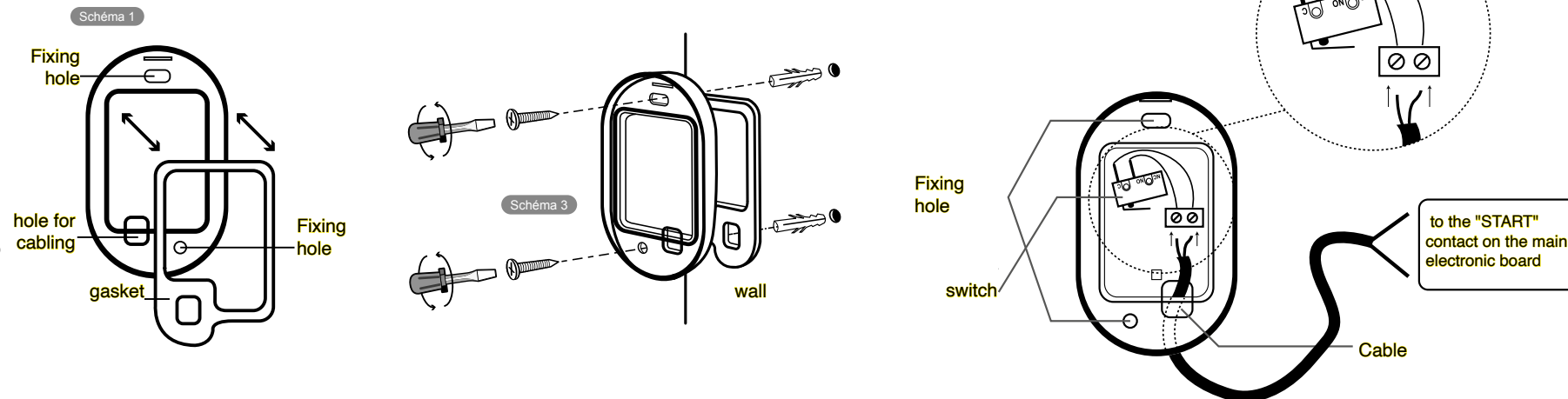
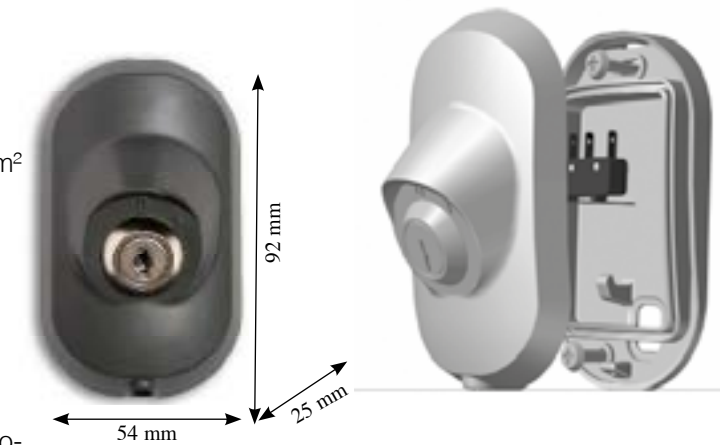

Bulb 12V max 10W the flashing light is important to indicate a moving engine

Installation:

- 1- Open the flashing light.
- 2- Unscrew the 2 screws inside.
- 3- Remove the lower part.
- 4- Define the position of the flashing light and then locate the punch positions.
- 5- Plan for cable routing.
- 6- Secure the flashing light with screws and plugs (not included).
- 7- Screw in the bulb (supplied) and then close the flashing light.

Electrical connection

Recommended cable: 2 x 0,5mm².

- 1 – Pull the cable from the flashing light to the board.
- 2 – Route the cable through the control box cable entry holes.

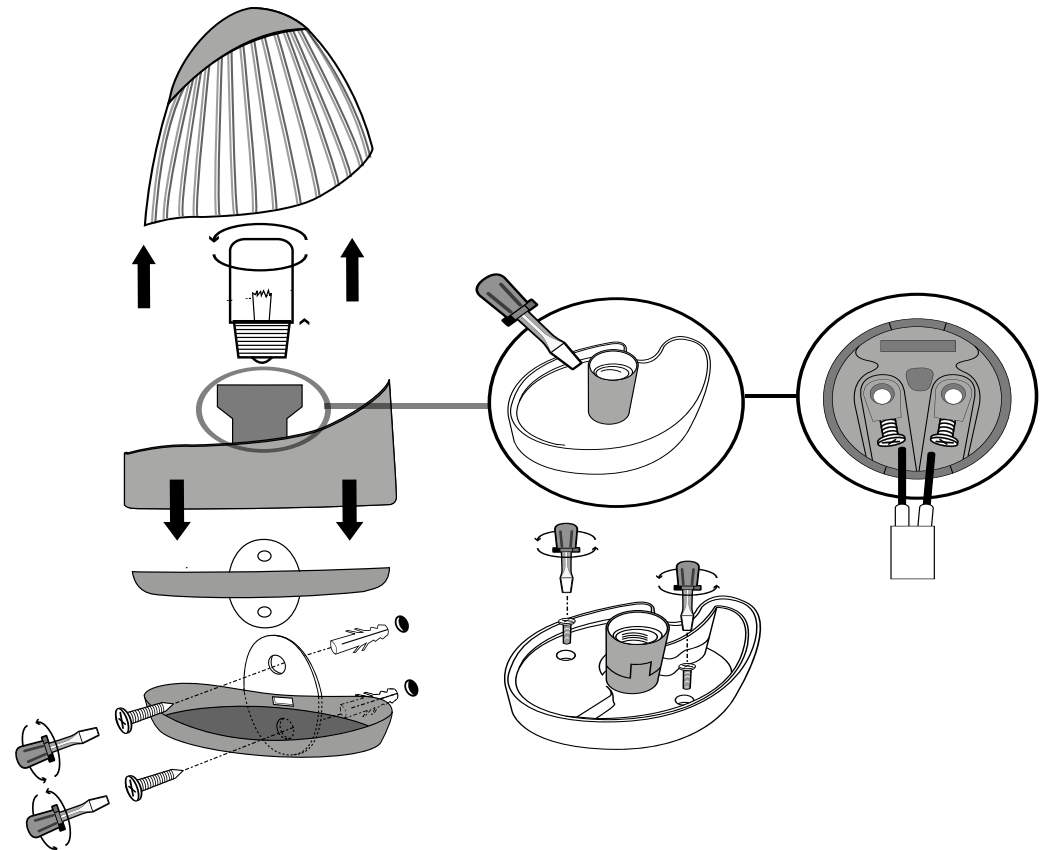

DUCATI Photocells LASER 100/LASER 100B/LASER 200

LASER 100...universal photocell set. 12V / 24V ac / dc power supply with NC contact (normally closed) + NO contact (normally open).

LASER 100/B...universal photocell set. 12V / 24V ac / dc power supply with NC (normally closed) or NO (normally open) contact).

LASER 200...universal photocell set. Power supply 12V / 24V ac / dc with NC contact (normally closed) + NO contact (normally open) body with 90° rotation.

Remove the front cover by unscrewing the bracket screws. Fix the photocells to the pillar / wall or column. Use sealant to prevent liquid infiltration and insects from passing through the mounting holes. For wiring, use an external cable with a section of min. 0.3mm square. Perfectly align the emitting photocell and the receiving photocell. Check that the alignment is correct before finally fixing it. The maximum distance between the photocell emitter and the photocell receiver = 10 m.

Use of photocells as a safety device to avoid contact during closing:

Power the photocells and connect the NC contact (normally closed) to the corresponding FTC terminals on the electronic board of your motor. Do not use the NO (normally open) contact on the photocell.

If the infrared ray reception is interrupted during the gate closing maneuver, the gate stops and the movement is reversed. As long as the contact remains open, the gate no longer closes until the alignment of the infrared ray is re-established and the contact is closed.

Use of photocells as an opening control system:

Power the photocells and connect the NO contact (normally open) to the "START" contact of the electronic board of your motor. Do not use the NC (normally closed) contact of the photocell.

If the infrared ray reception is interrupted, the gate will start an opening cycle. It is recommended to pay attention and take into account that this type of use can lead to involuntary opening maneuvers to the passage of animals / children.

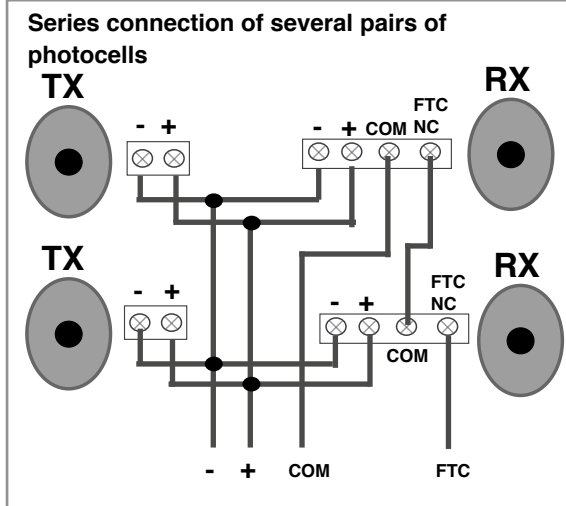

LASER 100

TX terminals: 1, 2

RX terminals: 1, 2, 3, 4, 5

Connections:

- 1 = - negative power supply 12 / 24V ac / dc.
- 2 = + positive power supply 12 / 24V ac / dc.
- 3 = NO contact (normally open) (START).
- 4 = common COM.
- 5 = NC contact (normally closed) (FTC).

LASER 100B

WARNING: When connecting the photocells, remove the bridge that keeps the FTC-COM contact closed on the electronic board of your automation.

TX terminals: 1, 2

RX terminals: 1, 2, 3, 4

Connections:

- 1 = - negative power supply 12 / 24V ac / dc.
- 2 = + positive power supply 12 / 24V ac / dc.
- 3 = common COM.
- 4 = OUT = contact which, depending on the selected position of the "JUMPER" switch, becomes a NO contact (normally open) or a NC contact (normally closed).

NC ↔ NO

LASER 200

TX terminals: 1, 2

RX terminals: 1, 2, 3, 4, 5

Connections:

- 1 = - negative power supply 12 / 24V ac / dc.
- 2 = + positive power supply 12 / 24V ac / dc.
- 3 = NC contact (normally closed).
- 4 = common COM.
- 5 = NO contact (normally open).

Warranty conditions and after sales service

MANUFACTURER'S LIMITED WARRANTY CONDITIONS

- 1) The warranty is valid only if it is attributable to an original defect of the product.
- 2) Warranty period: 24 months from the date of sale.
- 3) If, during the period of this limited warranty, the product appears to contain a defect covered by this warranty, the customer must follow the after-sales service procedure.
- 4) The manufacturer's obligations are limited to repairing or, at its option, replacing defective parts / components due to an inherent defect in the product or component. Refund for a defective product is never applicable. Defective parts will be repaired or replaced with new parts at the manufacturer's discretion.
- 5) Transportation, handling or installation costs related to this product, for any reason, including the cost of returning parts for inspection and after-sales service under warranty or out of warranty, are not included in the warranty and are payable. Due to the manufacturer.
- 6) The warranty is void immediately if the product has been modified, manipulated or adapted in any way, the guarantee is void immediately if the product has been installed or used in a structure that does not comply with the manufacturer's instructions for installation and use. No reimbursement is granted for direct or indirect damages resulting from the aforementioned changes.
- 7) The warranty does not cover under any circumstances:
 - a) Costs of installation, periodic checks, maintenance, relocation, reinstallation of a repaired or replaced unit.
 - b) Parts subject to wear such as: fuses, cells, batteries, carbon brushes, light bulbs, etc. They are never included in the warranty.
 - c) Transportation, handling or installation costs related to this product, for any reason, including the cost of returning parts for inspection and after-sales service under warranty or out of warranty, are not included in the warranty and are payable only at the customer's expense. Problems caused by improper use or in non-ideal or non-standard construction, user error, damage not due to failure, damage caused by improper installation or operation, including unauthorized repairs or any other alteration of the product, are not covered from guarantee.
 - d) Damage caused by fire, moisture, water, natural phenomena, electrical storms, radio interference or other interference from other electrical devices; short circuit or any failure resulting from incorrect power supply, or variation of the supply voltage, or any other cause beyond the manufacturer's control.
- 8) Proper operation of the device will depend on compliance with the manufacturer's installation, operation and maintenance instructions.
- 9) Under no circumstances can the manufacturer be held responsible for any direct or indirect incidental damage or cost deriving from the use or inoperability of the product. Any problems / after-sales assistance, even if they fall within the warranty conditions, do not grant any right to financial compensation to the manufacturer, nor any right to issue debit notes or refund requests.

Warranty conditions and after sales service

This product has a 2 year warranty against any material or manufacturing defect under normal use and in accordance with the recommendations for use. During the warranty period, remember to bring your proof of purchase (purchase receipt or warranty certificate) which will be required if you need to return the product to your dealer.

The warranty does not cover damage resulting from abnormal or abusive use or damage due to power surges or lightning. Opening devices or modifying them by users voids the warranty. The responsibility of the manufacturer is limited to the replacement of products recognized as defective or their repair, but does not extend in any case to the consequences deriving from their commissioning, use, non-functioning or poor maintenance.

The manufacturer reserves the right to modify at any time, in the interest of the consumer, the characteristics or components of its products, without notice.

Register on our website to receive numerous offers on other accessories and other products in our range.

Our commitments

- Support you in improving your home by offering you a complete range of simple, aesthetic, innovative and reliable products.
- Anticipate new trends and lifestyles and share them.
- Provide a minimum two year warranty on our entire range.
- Give you total satisfaction through the quality of our products and services.

More information

Our service is at your disposal 7 days a week, 24 hours a day, to guide you in the selection, installation and use of our products.

contact us and visit our websites: www.ducatihome.it and www.apritu.it

DUCATI HOME AUTOMATION

Automazione Cancelli

Via Cassani snc 43036 Fidenza (PR) Italy

After sales service

Contact our after-sales service: competent technicians always at your disposal.

www.ducatihome.it info@ducatihome.it www.apritu.it info@apritu.it

ASSISTANCE SERVICE 7/24H MOBILE PHONE 0039 335 1022019 (Also available on whatsapp)

Phone +39-0524-293117 Phone 0039-0524-527967 Fax 0039-0524-591085

www.ducatihome.it

**SUPPORT 7/24h
ADVICE**

**VIDEO -NOTICES
INDEPENDENT PIECES**

PROMO

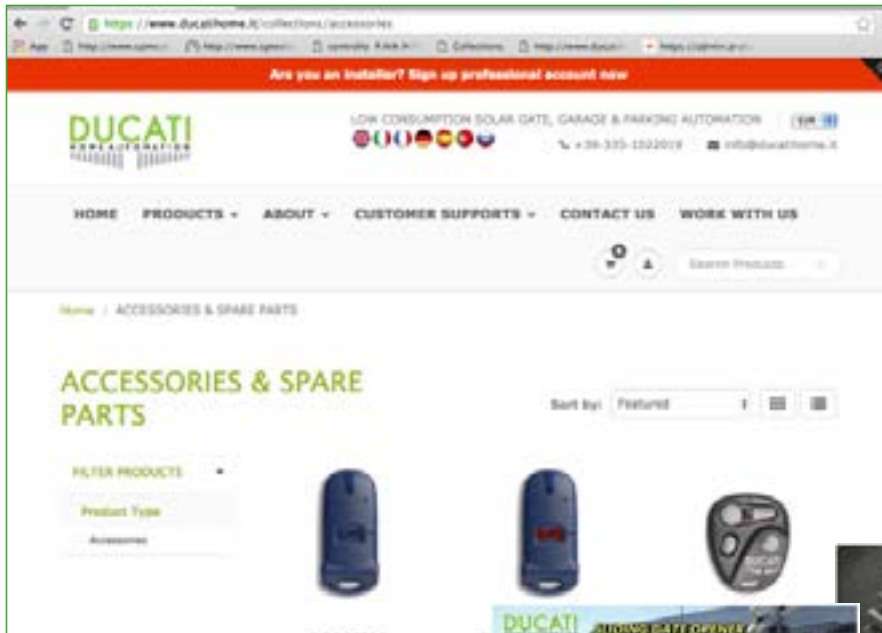



REGISTER ON OUR SITE

www.ducatihome.it

TO BENEFIT FROM MANY OFFERS AND
PROMOTIONS!

ALSO ACCESS OUR VIDEO-NOTICES!

[d u c a t i h o m e . i t](http://www.ducatihome.it)

Ducati Home Automation

Automazione cancelli
via Cassani
43036 Fidenza (PR) ITALY
Phone +39-0524-527967
Phone +39-0524-591085
Phone 0039-335-1022019
info@ducatihome.it